

ROBINSON HELICOPTER COMPANY

R44 MAINTENANCE MANUAL AND INSTRUCTIONS FOR CONTINUED AIRWORTHINESS RTR 460 VOLUME I

Production Certificate Number 424WE

Type Certificate Number H11NM



Robinson Helicopter Company
2901 Airport Drive
Torrance, California 90505-6115
United States of America

Phone: (310) 539-0508
Fax: (310) 539-5198
Web: <https://robinsonheli.com>

OFFICE HOURS

Monday through Friday, 7:30 a.m. to 4:30 p.m., Pacific Time.
Lunch hour is 11:30 a.m. to 12:30 p.m.

HOLIDAYS

Please visit <https://robinsonheli.com> for a list of holidays and company shutdowns.

CUSTOMER SUPPORT AND SPARES ORDERS

Please visit <https://robinsonheli.com> for Customer Support contact information. Procure parts from any R44 Dealer or Service Center, or order directly from RHC Customer Service via email, fax, or phone.

PUBLICATIONS

Viewing RHC Maintenance Manuals (MMs) and Illustrated Parts Catalogs (IPCs) online at <https://robinsonheli.com> is recommended to ensure use of current data. Viewing MMs and IPCs offline via paper or digital download requires verification that the data is current. Refer to the online MM or IPC Revision Log for the list of current pages.

SUBSCRIPTION ORDER AND RENEWAL FORMS

Subscription order and renewal forms are located at <https://robinsonheli.com>.

WARRANTY INFORMATION

Helicopter and parts warranty information is located at <https://robinsonheli.com>.

CHAPTER LIST

	Introduction
Chapter 1	General
Chapter 2	Inspection
Chapter 3	Life-Limited Components
Chapter 4	Airframe
Chapter 5	Landing Gear
Chapter 6	Powerplant
Chapter 7	Drive Train
Chapter 8	Flight Controls
Chapter 9	Rotor Systems
Chapter 10	Rigging, Track and Balance
Chapter 11	Environment Control
Chapter 12	Fuel System
Chapter 13	Instruments
Chapter 14	Electrical and Avionics Systems
Chapter 15	Furnishings
Chapter 16	Dimensions and Descriptions
Chapter 17	Jacking and Hoisting
Chapter 18	Weight and Balance
Chapter 19	Ground Handling
Chapter 20	Parking and Storage
Chapter 21	Placards and Markings
Chapter 22	Servicing
Chapter 23	Standard Practices
Chapter 24	Autopilot
Chapter 25	Hydraulics
Chapter 26	Lights
Chapter 27	Doors and Windows
Chapter 28	Main Rotor
Chapter 29	Main Rotor Drive System
Chapter 30	Tail Rotor
Chapter 31	Tail Rotor Drive System
Chapter 32	Engine Controls
Chapter 33	Engine Oil System
Chapter 34	Police Version
Chapter 35	E.N.G. Version
Chapter 36	Cadet Version
Chapter 37	Electrical System
Chapter 38	Avionics
Chapter 39	Wiring Diagrams
Chapter 40	Special Tools
Chapter 41	Revision Log

Intentionally Blank

TECHNICAL PUBLICATIONS

RECOMMENDED CHANGE REPORT

Please direct recommended changes to RHC Technical Publications via the email address listed below, by phone, or by submitting a duplicate of this completed form by fax or mail. Please include or have available the information detailed in this form.

Recommended changes may include but are not limited to general comments, corrections, omitted information, or clarification of instructions.

Please send recommendations to:

Email: techpubs@robinsonheli.com
Phone: (310) 539-0508
Fax: (310) 539-5198

Robinson Helicopter Company
Attention: Technical Publications
2901 Airport Drive
Torrance, CA 90505-6115
United States of America

Date:	_____	Publication:	_____
Name:	_____	Chapter:	_____
Company:	_____	Section:	_____
Helicopter Model:	_____	Page:	_____
Serial Number:	_____	Revision:	_____
Phone:	_____		
Email:	_____		

COMMENTS:

Intentionally Blank

CHAPTER 1

GENERAL

<u>Section</u>	<u>Title</u>	<u>Page</u>
1.000	Introduction	1.1
1.001	RHC Maintenance Manual and Illustrated Parts Catalog Updates	1.1
1.002	R44 Maintenance Authorization	1.2
1.003	Component Maintenance Authorization	1.2
1.004	Maintenance Record	1.2
1.005	Notations	1.2A
1.006	RHC Maintenance Manual and Illustrated Parts Catalog References	1.2A
1.007	Definitions and Abbreviations	1.2B
1.008	Service Information	1.3A
1.100	Helicopter Servicing	1.3D
1.101	Scheduled Maintenance and Inspections	1.3D
1.102	Additional Component Maintenance	1.3E
1.115	Chip Detector Cleaning	1.4
1.120	Main Rotor Gearbox Drain and Flush	1.4
1.130	Tail Rotor Gearbox Drain and Flush	1.7
1.140	Clutch Actuator Lower Bearing Lubrication	1.8
1.150	Defueling	1.8
1.160	Storage	1.8A
1.170	Hydraulic Reservoir Filter Replacement	1.8A
1.180	Draining and Flushing Hydraulic System	1.8B
1.190	Bleeding Hydraulic System	1.8C
1.195	Lubrication of Swashplate Bearings	1.8G
1.200	Handling, Jacking, Hoisting, Leveling and Weighing	1.9
1.210	Ground Handling	1.9
1.211	Ground Handling Wheels Installation	1.9
1.212	Ground Handling Wheels Installation – Float Ship Landing Gear	1.10A
1.213	Moving the Helicopter on Ground Handling Wheels	1.11
1.214	Main Rotor Blade Tie-Downs	1.11
1.215	Parking	1.11
1.216	Trailing	1.11
1.220	Jacking, Hoisting and Leveling	1.13
1.230	Weighing and CG Calculation	1.13
1.240	Fixed Ballast Installation	1.13
1.300	Fastener Torque Requirements	1.13
1.400	Approved Materials	1.13

CHAPTER 1

GENERAL (Continued)

<u>Section</u>	<u>Title</u>	<u>Page</u>
1.500	(Reserved)	1.13
1.600	Part Interchangeability	1.13
1.700	Assembly Instructions for R44-series Helicopter Crated for Export	1.14

CHAPTER 1

GENERAL

1.000 Introduction

The R44 Maintenance Manual contains instructions necessary for proper maintenance, servicing, and handling of R44-series helicopters. The R44 Instructions for Continued Airworthiness (ICA) includes the R44 Maintenance Manual (MM), R44 Illustrated Parts Catalog (IPC), R44 Service Bulletins (SBs), R44 Service Letters (SLs), Lycoming O-540-series and IO-540-series Operator's Manuals, applicable Lycoming technical publications, and applicable component manufacturer technical publications.

Service Bulletins are issued by Robinson Helicopter Company (RHC), Lycoming, and component manufacturers. RHC Service Bulletin compliance is mandatory; comply with other applicable Service Bulletins as directed. RHC technical publications are available online at www.robinsonheli.com. Recent technical publications are available from Lycoming at www.lycoming.com, and from Continental Motors, Inc. (CMI) at www.continentalmotors.aero.

Kit instructions are issued for field installation of either optional or mandatory (due to Service Bulletin or parts obsolescence) equipment upgrades, or provisions for upgrades. Kit instruction issued by RHC either implement approved type design data, or are approved as type design data.

A list of chapters is located in the *Introduction*. Chapters are separated by tab dividers and chapter contents are listed in the chapter front pages.

CAUTION

Always read instructions completely before performing a task.

1.001 RHC Maintenance Manual and Illustrated Parts Catalog Updates

RHC Maintenance Manuals (MMs) and Illustrated Parts Catalogs (IPCs) are available digitally at www.robinsonheli.com, under the Publications tab. Access to these publications does not require an account and is free of charge.

Viewing MMs & IPCs online is recommended to ensure use of current data.

Viewing MMs & IPCs offline via paper or digital download requires verification that the data is current. Refer to the online MM or IPC Revision Log for the list of current pages.

Sign up for free email notification of revisions to MMs & IPCs by sending an email to subscriptions@robinsonheli.com with "Subscribe email" in the subject line. Within the email, include name, email address, physical address, and helicopter model(s) of interest.

1.002 R44 Maintenance Authorization

Only appropriately certificated mechanics who have successfully completed an R44 factory-sponsored maintenance course, or are under direct supervision of the above-stated mechanic, may perform maintenance, repairs, or inspections on R44-series helicopters. Annual inspections of U.S.-registered light helicopters must be performed by holders of an Inspection Authorization (IA) or by repair stations certificated by the Federal Aviation Administration (FAA). The daily preflight and some preventive maintenance may be performed by the above-stated mechanics, or by the pilot/owner after receiving appropriate instruction in accordance with the R44/R44 II/R44 Cadet Pilot's Operating Handbook and applicable aviation regulations.

1.003 Component Maintenance Authorization

Only appropriately certificated mechanics who have successfully completed both a factory-sponsored maintenance course and component maintenance course, and who possess technical data supplied by RHC, are authorized to perform maintenance specified in the Component Maintenance Manual (CMM). Component maintenance may only be performed at an RHC-authorized Service Center that has required Component Maintenance special tools (ref. R44 SL-67) and holds a Repair Station certificate (or foreign equivalent).

1.004 Maintenance Record

Blank, digital Airframe Maintenance Record forms are available online at www.robinsonheli.com.

Airframe Maintenance Record blank PDF forms may be used for R22-series, R44-series, and R66 Turbine helicopters. Component Record blank PDF forms may be used for life-limited or TBO components. Blank paper copies are available for purchase (P/N R8478 Airframe Maintenance Record and P/N R8479 Component Record [pack of 20]).

A Component Record is a maintenance record of the removals, installations, or maintenance performed on a life-limited or TBO component. When a life-limited or TBO component is installed in the helicopter, the Component Record card is inserted in the Airframe Maintenance Record. When a life-limited or TBO component is removed from the helicopter, remove the Component Record card and keep the card with the Component. Major assemblies may contain one or more life-limited or TBO component.

RHC encourages operators to utilize Component Record cards to assist in tracking time on interchangeable parts since service lives may be different between models.

RHC does not create Component Record cards for spares; however, operators may create their own.

RHCs Repair Station does not require a Component Record card in order to perform work on a component, unlike a Component/Return Authorization form.

RHC recommends using a toner-based laser, or a pigment-based inkjet, color printer and 65 lb white (96 bright) premium card stock for Maintenance Record or Component Record card production. Maintenance Record binders and tab sets are available separately (P/N R8656 Maintenance Record Binder and P/N R8650 Maintenance Record Tabs).

1.005 Notations

The following notations will be found throughout the manual:

NOTE

A NOTE provides emphasis or supplementary explanation.

CAUTION

Equipment damage can result if a CAUTION is not followed.
--

WARNING

Personal injury or death can result if a WARNING is not followed.

1.006 RHC Maintenance Manual and Illustrated Parts Catalog References

Maintenance Manual and Illustrated Parts Catalog Section and Figure references are subject to relocation and renumeration. Effort will be made at the time of RHC technical document revisions to correct superseded references, however, certain documents may not otherwise require revision and superseded references may remain. A keyword or part number search in online documents (Ctrl + F [PC] or Command + F [Mac]) may help to locate applicable data.

1.007 Definitions and Abbreviations

Refer to R44/R44 II/R44 Cadet Pilot's Operating Handbook (POH) Section 1, as applicable, for additional definitions and abbreviations.

A. Definitions

- 14 CFR § 27.602 Critical Part: C016-x main rotor blades & C029-x tail rotor blades are critical parts as defined by 14 CFR § 27.602 and are subject to special inspection requirements & reporting described in Chapters 28 & 30. Contact RHC Technical Support if questions arise concerning special inspection or reporting requirements.
- 12 years: With respect to a 12 year inspection or life-limit, 12 years means 12 years from the date of the:
- factory-issued airworthiness certificate,
 - factory-issued authorized release certificate (FAA Form 8130-3, Airworthiness Approval Tag), or
 - last 12-year inspection.
- Annually: With respect to an annual inspection, annually means within the preceding 12 calendar months.
- Datum: An imaginary vertical plane from which all horizontal measurements are taken for balance purposes with the aircraft in level flight attitude. Refer to § 16-20 for R44 datum location.
- Empty Weight: Standard empty weight of a standard helicopter including unusable fuel, full operating fluids, and full engine oil. Basic empty weight is standard empty weight plus weight of installed optional equipment. Refer to R44-series Type Certificate Data Sheet (TCDS) H11NM at: <https://drs.faa.gov>. Refer to helicopter's Equipment List/Weight and Balance Data Sheet (RF 134) and Weight and Balance Record in R44/R44 II/R44 Cadet POH Section 6, as applicable, for installed equipment.
- Life-Limited Part: Refer to Chapter 3. Any part for which a mandatory replacement limit is specified in the type design, the Instructions for Continued Airworthiness, or the maintenance manual.
- Time in Service: With respect to maintenance time records, time in service means the time from the moment an aircraft leaves the surface of the earth until it touches it at the next point of landing.

1.007 Definitions and Abbreviations (continued)**B. Abbreviations**

14 CFR:	Title 14 of the Code of Federal Regulations. The Federal Aviation Regulations (FARs) are part of the CFR.
AOG:	Aircraft on Ground
Assy:	Assembly (component consisting of more than one part)
ATA-100:	Air Transport Association of America Specification No. 100
BL:	Butt Line Station locations
CO:	Carbon Monoxide
CRA:	Component Return/Authorization
ELT:	Emergency Locator Transmitter
EMU:	Engine Monitoring Unit
FS:	Fuselage Station locations
GPM:	Gallons Per Minute
HID:	High Intensity Discharge
HS:	Horizontal Stabilizer Station locations
ICA:	Instructions for Continued Airworthiness
LBL:	Left Butt Line Station locations
LED:	Light Emitting Diode
LH:	Left-hand
LRU:	Line-Replaceable Unit
MR:	Main Rotor
MRB:	Main Rotor Blade
MRDS:	Main Rotor Drive Shaft
MRGB or MGB:	Main Rotor Gearbox or Main Gearbox
OEM:	Original Equipment Manufacturer
R44 IPC:	R44 Illustrated Parts Catalog
R44 MM:	R44 Maintenance Manual
R44 POH:	R44 Pilot's Operating Handbook
R44 II POH:	R44 II Pilot's Operating Handbook
R44 Cadet POH:	R44 Cadet Pilot's Operating Handbook
RBL:	Right Butt Line Station locations
RH:	Right-hand
RHC:	Robinson Helicopter Company
RS:	Rotor Station locations
SB:	Service Bulletin
SDS:	Safety Data Sheet
SL:	Service Letter
TBO:	Time Between Overhaul
TCDS:	Type Certificate Data Sheet
TIR:	Total Indicator Reading
TR:	Tail Rotor
TRB:	Tail Rotor Blade
TRDS:	Tail Rotor Drive Shaft
TRGB or TGB:	Tail Rotor Gearbox or Tail Gearbox
TS:	Tailcone Station locations
TSN:	Time Since New
TSO:	Time Since Overhaul
WL:	Water Line Station locations

1.008 Service Information

A. Part Designation

RHC parts are designated with an alphanumeric part number beginning with letter "A", "B", "C", etc., followed by three digits and a dash number.

A revision letter or letters follow(s) the stamped or ink-marked part number. Revision progression is A thru Z, followed by AA thru AZ, followed by BA thru BZ, etc. Unless otherwise specified, any revision of the same part number is interchangeable, such as "A101-1 A" and "A101-1 D".

A change in dash number indicates a change in form, fit, and/or function (e.g. part number C339-1 is not interchangeable with part number C339-10 even though both are jackshaft weldments for [hydraulic] R44s). Similarly, part numbers F049-6 and F049-06 are not interchangeable because the dash numbers are different.

B. Returning Parts

All parts shipped to RHC must include a signed Component Return/Authorization (CRA) Form available online at <https://robinsonheli.com>.

C. Ordering and Shipping

Procure parts from any R44 Dealer or Service Center, or order directly from assigned RHC Customer Service Representative via email, fax, or phone.

D. Warranty Claims

Complete CRA Form (refer to Part B) and, in the Warranty Claim section, indicate if rotorcraft or component is under warranty. If claim is for parts or for labor allowance due to a Service Bulletin issued against rotorcraft or component, write in "per SB-XX" adjacent to requested warranty action.

E. Customer Support

Please visit <https://robinsonheli.com> for Customer Support contact information.

Intentionally Blank

TABLE 1 SCHEDULED INSPECTIONS	First 10 hours	First 25 hours	First 100 hours	Every 50 hours	Every 100 hours	Every 300 hours	Every 500 hours	Every 2200/2400 hours	Every 4 months	Every 12 months	Every 24 months	Every 3 years	Every 5 years	Every 12 years	Every 15 years
Consult latest revision of listed publications for specific applicability.															
Perform inspection per Lycoming Operator's Manual.*	•	•		•	•	•									
Perform Lycoming SI 1129 <i>Methods of Checking DC Alternator and Generator Belt Tension.</i>		•			•										
Perform Lycoming SI 1191 <i>Cylinder Compression.</i>					•										
Perform Lycoming SB 301* <i>Maintenance Procedures and Service Limitations for Valves.</i>			•			•									
Perform Lycoming SB 342 (IO-540 Only) <i>Fuel Line (Stainless Steel Tube Assy.) and Support Clamp Inspection & Installation. Reference AD 2015-19-07.</i>					•										
Perform Lycoming SB 388* (also applies to replacement cylinders) <i>Procedure to Determine Exhaust Valve and Guide Condition.</i>			•			•									
Perform Lycoming SB 480 (and R44 SL-83, as applicable) <i>I. Oil & Filter Change & Screen Cleaning / II. Oil Filter/Screen Content Inspection. NOTE: Oil filters on D723-1 adapters do not require safety wire.</i>		•		•					•						
Perform CMI SB 643, as applicable <i>Maintenance Intervals for All CMI/TCM/Bendix Magnetos & Related Equipment.</i>					•		•							•	
Perform CMI SB 663 <i>Two-Wire Magneto Tach. Breaker Contact (Points) Assy. P/N 10-400507.</i>							•						•		
Perform 100-hour/annual inspection per § 2.400.					•					•					
Perform main rotor blade tip maintenance per § 28-60.					•					•					
Lubricate C181-3 bearing per § 1.140.						•						•			
Replace hydraulic filter per § 1.170.						•									
Drain and flush gearboxes per §§ 1.120 & 1.130.							•								
Clean gearbox chip detectors per § 1.115.							•			•					
Perform clutch assembly lubricant inspection & servicing per § 7.210.							•								
Verify magneto (or EIS) drive cushion pliability (must tolerate 180° bend).							•						•		
Perform 2200-hour/2400-hour/12-Year inspection per § 2.600.								•						•	
Perform pressure relief valve leakage check per § 12-83.										•					
Perform pop-out float leak check per § 5.630.										•					
Perform pop-out float inflation check per § 5.640.													•		
Perform pop-out float pressure cylinder hydrostatic test (per U.S. DOT-SP 10915).													•		
Pop-out float pressure cylinder maximum life.															•

* Gray square indicates a shorter interval than published on referenced document.

1.100 Helicopter Servicing

1.101 Scheduled Inspections

Required maintenance and inspection intervals are given in Table 1. Publications listed are subject to revision.

Also consult the following for specific applicability, as some aircraft may require maintenance and inspections in addition to the requirements in Table 1:

- Aircraft maintenance records
- Manufacturers' Service Bulletins (SBs)
- Aviation regulations
- Airworthiness Limitations
- Airworthiness Directives (ADs)

Preventive maintenance is required between scheduled inspections. Fluid leaks, discoloration, fretting, galling, chafing, nicks, scratches, dents, cracks, and corrosion all warrant further investigation. Unairworthy items must be replaced or repaired.

NOTE

If a component or an inspection is scheduled for hourly and calendar intervals, comply with whichever requirement comes first, then reset interval unless otherwise specified.

1.102 Additional Component Maintenance

NOTE

RHC-manufactured parts not listed in § 1.102 as requiring additional component maintenance, or replacement per § 3.300, are “on condition”.

A. 12 YEARS

Perform action indicated on the following components when they have accumulated 12 years calendar time and less than 2200 hours (R44 S/Ns 0001 thru 9999 & R44 II S/Ns 10001 thru 29999) or 2400 hours (R44 Cadet S/Ns 30001 & subsequent) time in service since new, since last overhaul, or since last 12-year maintenance:

Part Number	Description	Action
A120-3	Tail Rotor Bellcrank Assembly	Replace with new.
A130-48	Spacer	Replace with new, per R44 SL-80.
A190-3	V-Belt Set	Replace with new.
A336-6 or -9	Push-Pull Tube, Throttle (R44 II)	Visually inspect. If exterior corrosion is evident, record length, disassemble, and inspect tube interior. Repair or replace as required.
A462-4	Fitting (mixture control arm)	Visually inspect. Replace if worn or corroded.
A650-2 or -4	Fitting (MRGB mount)	Visually inspect, including bore. Replace if worn or corroded.
A785-6	Hose (bulkhead to MRGB)	Replace with new.
A785-7	Hose (alternator cooling)	Replace with new.
A785-10	Hose (carb heat scoop to airbox)	Replace with new.
A785-11	Hose (engine LH cowling to airbox)	Replace with new.
A785-12	Hose (scroll to muffler shroud)	Replace with new.
A785-13	Hose (muffler shroud to cabin heat inlet)	Replace with new.
A785-16	Hose (scroll to MRGB)	Replace with new.
A785-17	Hose (scroll to bulkhead)	Replace with new.
A785-19	Hose (magneto cooling)	Replace with new.
A785-28	Hose (bulkhead to hydraulic reservoir)	Replace with new.
A785-31	Hose (R44 II engine air intake)	Replace with new.
A785-32	Hose (alternator cooling)	Replace with new.
A918-1 thru -8	Elastic Cord – Tail Rotor	Replace with new. Dash number is selected during flight test evaluation.
A947-2	Flex Plate Assembly (bonded)	Visually inspect with 10x magnification. Replace if any bonded washer evidences separation (8 places). Replace if corrosion is evident.

1.102 Additional Component Maintenance (continued)

A. 12 YEARS (continued)

Part Number	Description	Action
B173-2, -3, or -6	V-Belt – Alternator	Replace with new.
B173-4	V-Belt – A/C Compressor Drive	Replace with new.
B283-1	Hose Assembly (oil pressure sender)	Replace with new.
B283-3	Hose Assembly (fuel; various)	Replace with new.
B283-7	Hose Assembly (fuel control to flow divider)	Replace with new.
B283-10	Hose Assembly (engine-driven pump to fuel control)	Replace with new.
B283-11	Hose Assembly (fuel return)	Replace with new.
C005-4	Main Rotor Hub (C154-1) & Bearing Assembly	Perform inspection and repair per § 28-22, return to RHC for inspection and repair, or replace with new.
C005-12	C016-7 Main Rotor Blade & C158-1 Spindle Assembly	Submit to RHC-authorized component maintenance facility for 12-year service, or replace with new or overhaul exchange. 12-year maintenance includes blade replacement (as required), pitch horn screw replacement, boot and O-ring replacement, and inspection.
C006-3, -6, or -8	Main Rotor Gearbox Assembly	Submit to RHC Repair Station for 12-year service, or replace with new or overhaul exchange. 12-year maintenance includes pinion seal replacement, O-ring replacement, sealed bearing replacement, rubber mount replacement, and inspection.
C007-5	Fanshaft Assembly	Inspect C181-3 bearing per § 2.502 step 3. Lubricate per § 1.140.
C008-4	Tail Rotor Assembly	Replace with new C008-9 tail rotor assembly.
C008-9	Tail Rotor Assembly	Disassemble. Remove bushings and teeter hinge bearings. Inspect hub; verify no fretting or corrosion. Fluorescent penetrant inspect hub. Replace blades as required. Replace teeter hinge bearings and blade attach bolts.
C011-2 & -3	Arm Assembly – Throttle (forward & aft, R44)	Visually inspect. Replace with D756 if corrosion is evident. Verify bearing rotates smoothly without noise.
C014-X	Landing Gear Assembly	Perform 12-year service per § 2.650 Part A.
C015-1	Cabin Assembly	Remove B270-1 sealant from aft-side of aluminum C259 panels at junction of steel horizontal firewall and inspect panels for corrosion. Repair as required. Replace sealant.
C017-4	Swashplate Assembly	Perform 12-year service per § 2.640, or replace with new or overhaul exchange C017-6 swashplate.

1.102 Additional Component Maintenance (continued)

A. 12 YEARS (continued)

Part Number	Description	Action
C017-6	Swashplate Assembly	Perform 12-year service per § 2.640, or replace with new or overhaul exchange.
C018-2 or -3	Clutch Assembly (C166-4 shaft)	Replace with new or overhaul exchange C018-4 or -5 clutch assembly.
C018-4 or -5	Clutch Assembly (C166-5 shaft)	Submit to RHC-authorized component maintenance facility, or replace with new or overhaul exchange. 12-year maintenance includes plug, seal and O-ring replacement, C184 bearing lubrication, and inspection.
C020-1 or -2	C020-1 (standard) or C020-2 (tie-down provisions) Upper Frame Assembly	Visually inspect for corrosion. If corrosion is found, remove paint per § 23-71 and MPI per § 23-41. Powder coat per § 23-76 (preferred), or prime & paint per §§ 23-75 & 23-77.
C021-1	Tail Rotor Gearbox Assembly	Perform 12-year service per § 2.610, or replace with new or overhaul exchange.
C031-1	Tail Rotor Pitch Control	Replace with new.
C041-11	Bearing Assembly – TRDS Damper	Replace with new.
C046-1, -19, -21, or -23	Lower Frame Assembly – LH	Visually inspect for corrosion. If corrosion is found, remove paint per § 23-71 and MPI per § 23-41. Powder coat per § 23-76 (preferred), or prime & paint per §§ 23-75 & 23-77.
C046-2	Lower Frame Assembly – RH	Visually inspect for corrosion. If corrosion is found, remove paint per § 23-71 and MPI per § 23-41. Powder coat per § 23-76 (preferred), or prime & paint per §§ 23-75 & 23-77.
C051-1 or -2	Clutch Actuator Assembly	Submit to RHC Repair Station for 12-year service, or replace with new or overhaul exchange.
C119-2	Bumper – Tail Rotor	Replace with new.
C121-1, -3 or -30, -19, & -24 or -28	Push-Pull Tube Assembly – Main Rotor	Visually inspect. If exterior corrosion is evident, record length, disassemble, and inspect tube interior. Repair or replace as required.
C121-9, -15, & -17	Push-Pull Tube Assembly – Tail Rotor	Visually inspect. If exterior corrosion is evident, record length, disassemble, and inspect tube interior. Repair or replace as required.
C121-21	Push-Pull Tube Assembly – Throttle	Visually inspect. If exterior corrosion is evident, record length, disassemble, and inspect tube interior. Repair or replace as required.
C121-25 or -31	Push-Pull Tube Assembly – Swashplate	Measure & record overall length. Remove rod ends and visually inspect, including tube interior. Replace if corrosion is evident.
C169-3, -32, -36, or -38	Muffler Assembly	Visually inspect muffler interior; verify no obvious damage and no loss of material.
C174-1 Revision A thru F	Support (engine mount at prop governor pad; constant 0.5-inch dia. vertical tube)	Replace with new C174-1 Revision G or subsequent.

1.102 Additional Component Maintenance (continued)

A. 12 YEARS (continued)

Part Number	Description	Action
C174-1 Revision G or subsequent	Support (engine mount at prop governor; vertical tube lower portion is 0.562 inch dia.)	Remove rod ends and visually inspect, including tube interiors. Replace if corrosion is evident.
C258-1	Main Rotor Pitch Link Assembly	Replace with new C258-5 link assembly.
C258-5	Main Rotor Pitch Link Assembly	Perform inspection per § 2.630, or replace with new.
C315-9	Support Weldment – Lower Aft Flight Controls	Visually inspect. If exterior corrosion is evident, remove and inspect tube interior. Repair or replace as required.
C319-5	Torque Tube – Cyclic	Visually inspect. If exterior corrosion is evident, remove and inspect tube interior. Repair or replace as required.
C334-4	Bellcrank Assembly (Collective)	Visually inspect. If exterior corrosion is evident, remove and inspect tube interior. Repair or replace as required. Verify bearings rotate smoothly without noise.
C336-1	Push-Pull Tube Assembly, Throttle (R44)	Visually inspect. If exterior corrosion is evident, record length, disassemble, and inspect tube interior. Repair or replace as required.
C339-1 or -10	Jackshaft Weldment	Visually inspect. Repair or replace as required.
C343-1*, -9, & -11 (*R44 SL-43 refers)	Push-Pull Tube Assembly – Tail Rotor	Visually inspect. If exterior corrosion is evident, record length, disassemble, and inspect tube interior. Repair or replace as required.
C343-8	Tube – Aft Servo	Visually inspect. If exterior corrosion is evident, record length, disassemble, and inspect tube interior. Repair or replace as required.
C348-1	Anchor Assembly – Collective Stop	Visually inspect. If exterior corrosion is evident, remove and inspect tube interior. Repair or replace as required.
C348-5	Anchor Assembly – Seat Belt (Forward)	Replace if seat buckle attaching lugs are less than 0.073 inch thick. Visually inspect. If exterior corrosion is evident, remove and inspect tube interior. Repair or replace as required.
C480-1	Swashplate Boot	Replace with new.
C608-1	Support Weldment – Throttle Bellcrank	Visually inspect. If exterior corrosion is evident, remove and inspect tube interior. Repair or replace as required.
C649-1	Oil Cooler	Replace with new or overhauled C649-2 oil cooler.
C649-2 & -3	Oil Cooler	Flush & 400-psi pressure test or overhaul or replace with new.
C792-4 or -5	Dual Tachometer	Submit to RHC Repair Station for 12-year service, or replace with new or overhaul exchange.

1.102 Additional Component Maintenance (continued)

A. 12 YEARS (continued)

Part Number	Description	Action
C907-1 or -2 Revision A thru G (weldment)	Yoke – Clutch Shaft Forward (1.43-inch dia. center hole between arms)	Replace with new C907-1 or -2 Revision H or subsequent yoke.
C907-1 or -2 Revision H or sub- sequent (forging)	Yoke – Clutch Shaft Forward (1.471-inch dia. bore)	Visually inspect using 10x magnification for obvious damage; replace yoke if damaged.
C918-15	Elastic Cord – Collective	Replace with new A918-20 cord.
C947-1 & -3	Flex Plate Assembly (bonded)	Visually inspect with 10x magnification. Replace if corrosion is evident. Replace if any bonded washer evidences separation (8 places).
D046-1 & -2	Strut Weldment – LH	Visually inspect for corrosion. If light corrosion is found, remove corrosion & paint per § 23-71 and MPI per § 23-41. Powder coat per § 23-76 (preferred), or prime & paint per §§ 23-75 & 23-77.
D046-3	Strut Weldment – RH	Visually inspect for corrosion. If light corrosion is found, remove corrosion & paint per § 23-71 and MPI per § 23-41. Powder coat per § 23-76 (preferred), or prime & paint per §§ 23-75 & 23-77.
D151-2	Stop (teeter, 2 each)	Replace with new.
D174-2	Fanwheel	Perform 12-year service per § 2.620, or replace with new or overhaul exchange.
D201-5	Support Assembly – Hydraulic Servos (fwd)	Replace with new D201-6 support assembly. Use NAS6604H16 bolt & NAS1149F0432P washer and safety wire (4 places) to secure servos.
D203-1	Support Assembly – LH (aft servo)	Visually inspect. If exterior corrosion is evident, record length, disassemble, and inspect tube interior. Repair or replace as required.
D204-8	Support Assembly – RH (aft servo)	Visually inspect. If exterior corrosion is evident, record length, disassemble, and inspect tube interior. Repair or replace as required.
D207-1	Strut Weldment – Jackshaft, Forward	Visually inspect. If exterior corrosion is evident, record length, disassemble, and inspect tube interior. Repair or replace as required.
D208-1	Strut Weldment – Jackshaft, Aft	Visually inspect. If exterior corrosion is evident, record length, disassemble, and inspect tube interior. Repair or replace as required.
D211-1 or -2	Hydraulic Reservoir	Perform 12-year service per § 2.660, or replace with new or overhaul exchange.
D212-1	Hydraulic Servo Actuators	Remove upper clevis, scissor, and D200-3 washer from servo, as applicable. Visually inspect threaded bore in piston shaft with borescope. Replace servo if corrosion is evident.
D224-1 or -2	Tail Rotor Drive Shaft	Remove yoke(s) and inspect shaft interior using borescope. Replace shaft if corrosion is evident.

1.102 Additional Component Maintenance (continued)
A. 12 YEARS (continued)

Part Number	Description	Action
D278-1 or -2	Governor Controller	Submit to RHC Repair Station for 12-year service, or replace with new or overhaul exchange.
D321-1	Valve – Pressure Relief (Fuel)	Replace with new or overhaul exchange.
D731-1	Bellcrank Assembly – Throttle, R44 II	Visually inspect. If exterior corrosion is evident, remove and inspect tube interior. Verify bearings rotate smoothly without noise. Repair or replace as required.
D731-9	Bellcrank Assembly – Throttle, R44 II (fuel control)	Visually inspect. Replace if corrosion is evident. Verify bearing rotates smoothly without noise.
D756-1	Bellcrank Assembly (forward, R44 II)	Visually inspect. Replace if corrosion is evident. Verify bearing rotates smoothly without noise.
D756-3 & -4	Bellcrank Assembly (forward & aft, R44)	Visually inspect. Replace if corrosion is evident. Verify bearing rotates smoothly without noise.
D778-1	Cartridge – Air Conditioning Pulley Drive (R44 II or Cadet only)	Replace with new or overhaul exchange.
D918-1 & -2	Elastic Cords – Cyclic	Replace with new.
NAS1149E0363R	Washer (corrosion resistant, mixture arm, 2 each)	Replace with new C141-26 washers, per R44 SL-80.
21FKF-518	Nut (exhaust riser, 12 each)	Replace with new.
21FKF-813	Jam Nut (MR pitch link, 2 each)	Replace with new.

1.102 Additional Component Maintenance (continued)

B. 2200/2400 Hours

Perform action indicated on the following components when they have accumulated 2200 hours (R44 S/Ns 0001 thru 9999 & R44 II S/Ns 10001 thru 29999) or 2400 hours (R44 Cadet S/Ns 30001 & subsequent) time in service since new or since last overhaul:

Part Number	Description	Action
A120-3	Tail Rotor Bellcrank	Replace with new.
A130-21	Spacer (at R44 and R44 Cadet powerplant controls)	Replace with new.
A130-48	Spacer	Replace with new, per R44 SL-80.
A190-3	V-Belt Set	Replace with new.
A336-6, -9	Push-Pull Tube – Throttle (R44 II)	Replace with new.
A462-4	Fitting	Replace with new.
A522-7	Control Cable – Mixture (carburetor)	Replace with new.
A522-13	Control Cable – Mixture (fuel control)	Replace with new.
A595-1	Seal – Vertical Firewall (neoprene)	Replace with new.
A595-2	Seal – Vertical Firewall (Teflon®)	Replace with new.
A650-2 or -4	Fitting – MRGB Mount	Visually inspect, including bore. Replace if worn or corroded. Magnetic particle inspect per § 23-41.
A729-33	Tube (aux fuel pump drain)	Replace with new.
A785-6	Hose (bulkhead to MRGB)	Replace with new.
A785-7	Hose (alternator cooling)	Replace with new.
A785-10	Hose (carb heat scoop to airbox)	Replace with new.
A785-11	Hose (engine LH cowling to airbox)	Replace with new.
A785-12	Hose (scroll to muffler shroud)	Replace with new.
A785-13	Hose (muffler shroud to cabin heat inlet)	Replace with new.
A785-16	Hose (scroll to MRGB)	Replace with new.
A785-17	Hose (scroll to bulkhead)	Replace with new.
A785-19	Hose (magneto cooling)	Replace with new.
A785-28	Hose (bulkhead to hydraulic reservoir)	Replace with new.
A785-31	Hose (R44 II engine air intake)	Replace with new.
A918-1 thru -8	Elastic Cord – Tail Rotor	Replace with new. Dash number is selected during flight test evaluation.
A947-2	Flex Plate Assembly (intermediate)	Replace with new.
B173-2, -3, or -6	V-Belt – Alternator	Replace with new.
B173-4	V-Belt – A/C Compressor Drive	Replace with new.
B277-024	Clamp	Replace with new.
B277-036	Clamp	Replace with new.

1.102 Additional Component Maintenance (continued)

B. 2200/2400 Hours (continued)

Part Number	Description	Action
B283-1	Hose Assembly (oil pressure sender)	Replace with new.
B283-3	Hose Assembly (fuel; various)	Replace with new.
B283-7	Hose Assembly (fuel control to flow divider)	Replace with new.
B283-9 or -11	Hose Assembly (fuel return)	Replace with new B283-11 hose assembly.
B283-10	Hose Assembly (engine-driven pump to fuel control)	Replace with new.
B345-4	Pitch Link (tail rotor)	Replace with new.
B350-3	Spring Pin (fanwheel retaining nut)	Replace with new.
C005-4	C154-1 Main Rotor Hub Assembly	Replace with new.
C005-12	C016-7 Main Rotor Blade & C158-1 Spindle Assembly	Replace with new or overhaul exchange C005-12 main rotor blade & spindle assembly, as required.
C006-3, -6, or -8	Main Rotor Gearbox Assembly	Replace with new or overhaul exchange C006-8 main rotor gearbox assembly.
C007-5	Fanshaft Assembly	Replace with new.
C008-4 or -9	Tail Rotor Assembly	Replace with new C008-9 tail rotor assembly.
C014-X	Landing Gear Assembly	Perform 2200-Hour/2400-Hour service per § 2.650 Part B.
C017-4 or -6	Swashplate Assembly	Replace with new or overhaul exchange C017-6 swashplate assembly.
C018-2 or -3	Clutch Assembly (C166-4 shaft)	Replace with new or overhaul exchange C018-4 or -5 clutch assembly.
C018-4 or -5	Clutch Assembly (C166-5 shaft)	
C020-1	Upper Frame Assembly (standard)	Replace with new.
C020-2	Upper Frame Assembly (with tie-downs)	Replace with new.
C021-1	Tail Rotor Gearbox Assembly	Replace with new or overhaul exchange.
C031-1	Tail Rotor Pitch Control	Replace with new.
C046-1, -19, -21, or -23	Lower Frame Assembly – LH	Remove paint per § 23-71 and MPI per § 23-41. Powder coat per § 23-76 (preferred), or prime & paint per §§ 23-75 & 23-77.
C046-2	Lower Frame Assembly – RH	Remove paint per § 23-71 and MPI per § 23-41. Powder coat per § 23-76 (preferred), or prime & paint per §§ 23-75 & 23-77.
C051-1 or -2	Clutch Actuator Assembly	Replace with new or overhaul exchange.
C106-X	Journal, Main Rotor Hub	Replace with new, or: Visually inspect using 10x magnification for obvious damage; magnetic particle inspect per § 23-41.

1.102 Additional Component Maintenance (continued)

B. 2200/2400 Hours (continued)

Part Number	Description	Action
C119-2	Bumper (tail rotor)	Replace with new.
C121-17	Push-Pull Tube (tailcone)	Replace with new.
C121-25 or -31	Push-Pull Tube Assembly – Swashplate	Disassemble, remove paint per § 23-71, fluorescent penetrant inspect per § 23-42, and replace as required. Clean, prime, & paint per § 23-60.
C152-1	Thrust Washer	Replace with new, or: Visually inspect using 10x magnification for obvious damage; magnetic particle inspect per § 23-41.
C169-1 or -35	Exhaust Muffler Assembly	Replace with new C169-35 assembly.
C169-31 or -37	Exhaust Muffler Assembly	Replace with new C169-37 assembly.
C174-1 Revision A thru F	Support (engine mount at prop governor pad; constant 0.5-inch dia. vertical tube)	Replace with new C174-1 Revision G or subsequent.
C174-1 Revision G or subsequent	Support (engine mount at prop governor; vertical tube lower portion is 0.562 inch dia.)	Magnetic particle inspect support.
C182-1	Nut (fanwheel retaining)	Replace with new.
C189-14	Nut (MR hub bolt)	Replace with new.
C258-1	Main Rotor Pitch Link Assembly	Replace with new C258-5 link assembly.
C258-5	Main Rotor Pitch Link Assembly	Replace with new, or perform inspection per § 2.630 and magnetic particle inspect barrel.
C339-1 or -10	Jackshaft Weldment	Visually inspect. Repair or replace as required.
C343-1*, -9, & -11 (*R44 SL-43 refers)	Push-Pull Tube Assembly – Tail Rotor	Visually inspect. If exterior corrosion is evident, record length, disassemble, and inspect tube interior. Repair or replace as required.
C348-5	Anchor Assembly – Seat Belt (Forward)	Replace if seat buckle attaching lugs are less than 0.073 inch thick. Visually inspect. If exterior corrosion is evident, remove and inspect tube interior. Repair or replace as required.
C480-1	Swashplate Boot	Replace with new.
C522-7	Control Cable – Carburetor Heat	Replace with new.
C568-1	Scoop Assembly (carburetor heat)	Replace with new.
C615-1	Gasket (airbox-to-carburetor)	Replace with new.
C627-4, -5, or -6	4-/5-point Harness Assembly	Replace with new.
C628-5, -6, -7, or -8	Connector Assembly	Replace with new.
C749-1	Nozzle Assembly (MRGB cooling)	Replace with new.
C792-4 or -5	Dual Tachometer	Replace with new or overhaul exchange.

1.102 Additional Component Maintenance (continued)

B. 2200/2400 Hours (continued)

Part Number	Description	Action
C907-1 or -2 Revision A thru G (weldment)	Yoke – Clutch Shaft Forward (1.43-inch dia. center hole between arms)	Replace with new C907-1 or -2 Revision H or subsequent yoke.
C907-1 or -2 Revision H or sub- sequent (forging)	Yoke – Clutch Shaft Forward (1.471-inch dia. bore) Yoke is heat-treated steel & cadmium-plated; do not remove gold-colored cadmium plating.	Replace with new, or: Liquid-strip paint using § 23-71 approved materials only. Visually inspect using 10x magnification for obvious damage; replace yoke if damaged or if cadmium plating is absent. Magnetic particle inspect per § 23-41. Chromate- epoxy prime, & topcoat non-clamping areas with white epoxy paint per § 23-60.
C918-15	Elastic Cord (collective)	Replace with new A918-20 cord.
C947-1 & -3	Flex Plate Assembly (forward & aft)	Replace with new.
D046-1 & -2	Strut Weldment – LH	Remove paint per § 23-71. MPI per § 23-41. Powder coat per § 23-76 (preferred), or prime & paint per §§ 23-75 & 23-77.
D046-3	Strut Weldment – RH	Remove paint per § 23-71. MPI per § 23-41. Powder coat per § 23-76 (preferred), or prime & paint per §§ 23-75 & 23-77.
D079-1	Tail Rotor Guard Assembly	Replace with new.
D082-1	Tube Assembly (weldment, TR guard)	Replace with new, or: liquid-strip paint per § 23-71, MPI per § 23-41, & prime per § 23-60.
D174-2	Fanwheel	Replace with new or overhaul exchange.
D201-5	Support Assembly – Hydraulic Servos (fwd)	Replace with new D201-6 support assembly. Use NAS6604H16 bolt & NAS1149F0432P washer and safety wire (4 places) to secure servos.
D203-1	Support Assy, LH – Aft Hydraulic Servo	Remove paint per § 23-71. MPI per § 23-41. Clean, prime, & paint per § 23-60.
D204-8	Support Assy, RH – Aft Hydraulic Servo	Remove paint per § 23-71. MPI per § 23-41. Clean, prime, & paint per § 23-60.
D211-1 or -2	Hydraulic Reservoir	Replace with new or overhaul exchange.
D212-1	Hydraulic Servo Actuators	Replace with new or overhaul exchange.
D224-1 & -2	Tail Rotor Drive Shaft Assembly	Replace with new.
D270-1	Governor Controller (with EMU)	Replace with new or overhaul exchange.
D278-1 or -2	Governor Controller	Replace with new or overhaul exchange.
D321-1	Valve – Pressure Relief (Fuel)	Replace with new or overhaul exchange.
D333-3	Fitting (carb heat control cable)	Replace with new.
D500-1	Hydraulic Pump	Replace with new or overhaul exchange.
D543-2	Spacer (fuel control throttle bellcrank)	Replace with new.

1.102 Additional Component Maintenance (continued)

B. 2200/2400 Hours (continued)

Part Number	Description	Action
D730-8	Brace (fuel control)	Replace with new.
D735-1	Sleeve – Fuel Control Inlet Fitting (orange, insulated)	Replace with new.
D743-1, -2, -3 or -4	Pump – Fuel (electric)	Replace with new D743-3 pump. For helicopter S/N 13158 and prior equipped with D743-1, -2, or -4 aux fuel pump, also order KI-206-3 Provisions Kit.
D778-1	Cartridge – Air Conditioning Pulley Drive (R44 II or Cadet only)	Replace with new or overhaul exchange.
D918-1 & -2	Elastic Cords – Cyclic	Replace with new.
D930-1	Mixture Spring (fuel control)	Replace with new.
F628-1	Connector Assembly	Replace with new.
F628-3	Connector Assembly	Replace with new.
F628-7	Buckle Assembly	Replace with new.
KI-6604	C017-5 Swashplate Installation Parts Kit Instructions	Replace existing parts with kit parts.
21FKF-518	Nut (exhaust riser, 12 each)	Replace with new.
AN3-41A	Bolt (oil cooler retaining)	Replace with new.
AN3-44A	Bolt (oil cooler retaining)	Replace with new.
AN735-4	Clamp (mixture cable-to-C577-2 bracket)	Replace with new.
MS16562-4	Spring Pin (in D333-3 fitting)	Replace with new.
MS20002-24	Washer (thick, fanwheel retaining nut)	Replace with new.
NAS1149E0363R	Washer (corrosion resistant, mixture arm, 2 each)	Replace with new C141-26 washers, per R44 SL-80.
NAS1149F2432P	Washer (thin, fanwheel retaining nut)	Replace with new.
NAS634-105	Bolt (MR hub)	Replace with new.

C. Engine Maintenance

Refer to latest revisions of Textron Lycoming Service Instruction No. 1009 and Lycoming Service Bulletin No. 240.

D. Airframe and Engine Accessory Maintenance

Refer to accessory manufacturer’s instructions for continued airworthiness for accessory maintenance. Remove accessories per R44 Maintenance Manual or accessory manufacturer’s instructions as required.

Intentionally Blank

1.115 Chip Detector Cleaning

NOTE

During normal operation of gearboxes using A257-2 oil, an insulating film of varnish can accumulate on a chip detector's magnet which could prevent metallic debris from illuminating the chip warning light. Proper cleaning of chip detectors per the following steps is critical to chip detector function.

WARNING

Review appropriate Safety Data Sheet (SDS) when working in proximity to hazardous materials. Specific recommendations for use of personal protective equipment are located in the SDS.

1. Remove and discard safety wire, if applicable, securing chip detector. Disconnect chip detector wiring from airframe harness at connectors. For tail gearbox, place suitable drain container below gearbox to catch oil and remove chip detector.
2. Clean chip detector using a toothbrush and approved solvent (refer to § 23-72). Remove debris using compressed air or masking tape; do not use a magnet. Dry chip detector using compressed air or a lint-free cloth. Inspect condition.
3. Connect chip detector wiring to airframe harness at connectors. Turn battery switch on. Touch detector's magnet to airframe and verify appropriate gearbox caution light illuminates. Turn battery switch off. Disconnect chip detector wiring from airframe harness at connectors.
4. Install chip detector. Special torque threaded-type chip detector per § 23-33; install safety wire as required (refer to R44 SL-45). Connect chip detector wiring to airframe harness at connectors.
5. Turn battery switch on. Depress push-to-test button(s) and verify appropriate gearbox caution light illuminates. Turn battery switch off.

1.120 Main Rotor Gearbox Drain And Flush

1. Run-up helicopter for approximately five minutes at 60–70% RPM per applicable Pilot's Operating Handbook (POH) Section 4 as required to warm oil and expedite draining.
2. Disconnect chip detector wiring from airframe harness at connectors. Remove chip detector from housing.
3. Check for oil leaking from chip detector housing. Leakage indicates housing is defective and must be replaced. If leakage occurs, immediately install main rotor gearbox drain assembly to minimize oil spillage.

1.120 Main Rotor Gearbox Drain and Flush (cont'd)

4. Drain oil by installing main rotor gearbox drain assembly in chip detector housing with drain hose overboard into a suitable container. Slide wedge under drain assembly to open valve (see Figure 1-2).
5. Remove drain assembly. Remove and discard safety wire securing gearbox filler plug. Remove plug.
6. Fill gearbox with SAE30, SAE40, SAE50, or SAE20W50 straight mineral engine oil to level indicated by decal adjacent to sight gage.
7. Install filler plug, tighten, but do not safety wire.
8. Ground run helicopter for approximately five minutes at 60-70% RPM.
9. After shutting down helicopter, drain gearbox using drain assembly.
10. Remove drain assembly. Remove and discard safety wire on chip detector housing. Remove chip detector housing and immediately place a small container under gearbox to catch any residual oil.
11. Clean chip detector with a toothbrush and cleaning solvent per Section 1.115. Compressed air or masking tape may also be used to remove debris but scrubbing with solvent is mandatory to remove any varnish accumulation. Do not use a magnet to remove debris. Clean and visually inspect chip detector housing.
12. Verify chip detector function by connecting electrical leads, turning Master switch on, and touching detector's central magnetic probe to horizontal firewall. MR CHIP warning light should illuminate. Disconnect electrical wires.
13. Install chip detector housing into main rotor gearbox. Torque per Section 1.330, and safety wire.
14. Install chip detector into chip detector housing. Torque threaded-type chip detector per Section 1.330 and safety wire. Connect chip detector electrical wires and ty-rap.
15. As required, remove sight gage and clean with solvent. Reinstall sight gage, torque per Section 1.330, and safety wire.
16. Remove filler plug. Fill gearbox with Robinson A257-2 lubricant to level indicated on decal. Rotate rotor system by hand several revolutions and pull down tailcone several times. Recheck gearbox oil level. Adjust as necessary.
17. Torque filler plug per Section 1.330 (safety wire not required).

1.120 Main Rotor Gearbox Drain and Flush (cont'd)

- 18. Turn on MASTER switch. Check chip detector operation by grounding detector's center terminal and verifying MR CHIP warning light illuminates. Turn off MASTER switch.

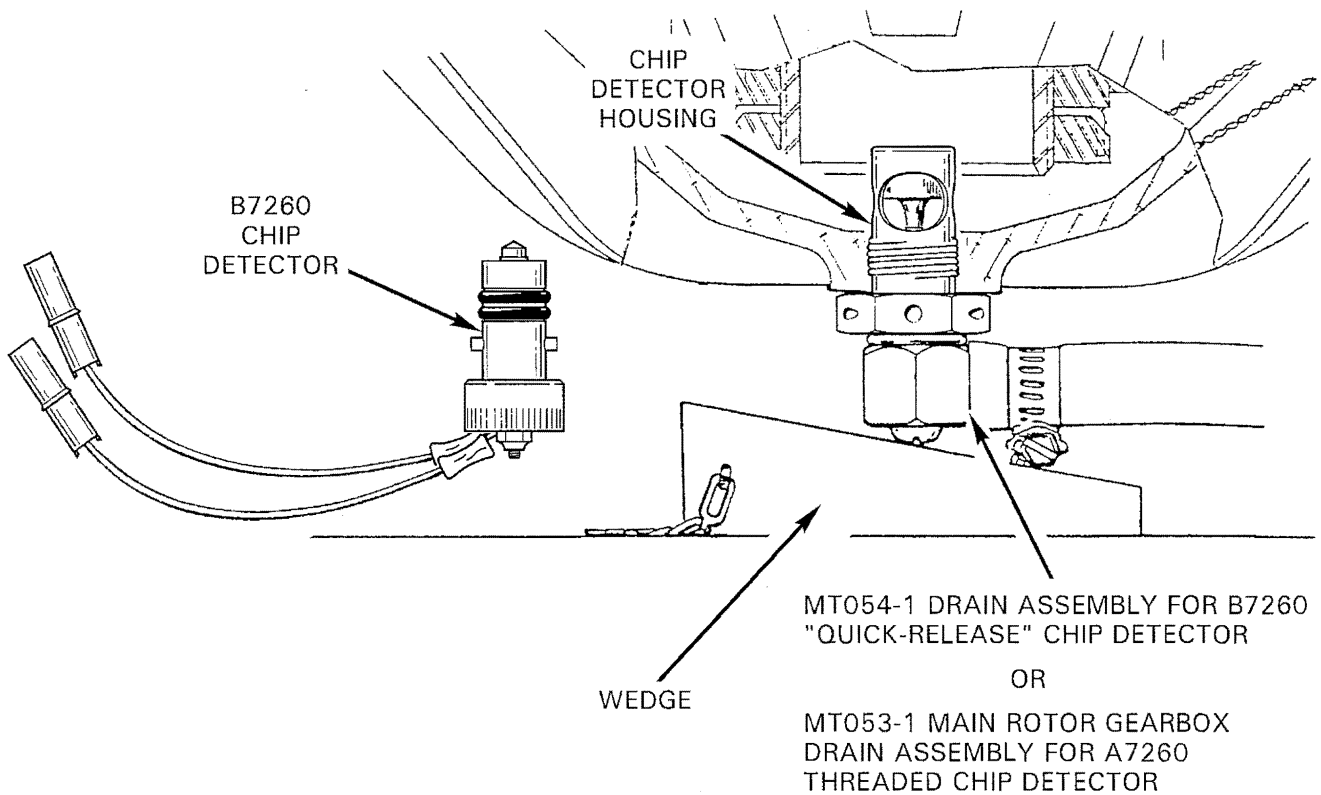

FIGURE 1-2 DRAINING MAIN ROTOR GEARBOX

1.130 Tail Rotor Gearbox Drain and Flush

1. Ground run helicopter for approximately five minutes at 60-70% RPM to warm tail rotor gearbox oil.
2. Disconnect chip detector wiring at quick-disconnect located approximately 11 inches from chip detector.
3. Remove and discard safety wire securing chip detector to sight gage.
4. Place a container under tail rotor gearbox to catch oil and remove chip detector.
5. Remove and discard safety wire securing filler-vent plug to sight gage. Remove filler-vent plug.
6. Install chip detector, torque per Section 1.330, but do not safety wire. Add approximately five ounces of SAE30, SAE40, SAE50, or SAE20W50 straight mineral engine oil.
7. Install filler plug, tighten, but do not safety wire.
8. Ground run helicopter at 60-70% RPM for approximately five minutes.
9. After shutting down helicopter, remove chip detector and drain mineral oil.
10. Clean and scrub chip detector with a toothbrush and cleaning solvent. Compressed air or masking tape may also be used to remove debris but scrubbing with solvent is mandatory to remove varnish accumulation. Do not use a magnet to remove debris.
11. Connect chip detector wiring. Turn on Master switch. Check chip detector operation by grounding detector's center terminal; TR CHIP warning light should illuminate. Turn off Master switch and disconnect chip detector wiring.
12. Install chip detector, torque per Section 1.330, and safety wire. Connect chip detector wiring and secure with Ty-raps® as required.
13. As required, remove sight gage and clean with solvent. Reinstall sight gage, torque per Section 1.330, and safety wire.

CAUTION

Tail rotor gearbox sight plug glass must indicate correct oil level when aircraft is on level ground.

14. Fill gearbox with Robinson A257-2 lubricant to level indicated by sight glass decal. Install filler-vent plug, torque per Section 1.330, and safety wire.
15. Turn on Master switch. Check chip detector operation. Turn off Master switch.

1.140 Clutch Actuator Lower Bearing Lubrication**NOTE**

Syringe suitable for the following procedure is included in kit KI-115, available from RHC Customer Service.

1. Fill syringe with 4-5 grams of A257-12 grease (commercially available, see Section 1.470). Note: 5 grams of grease fills a 1.0 inch (25 mm) long space inside a syringe body with a 0.63 inch (16 mm) inner diameter.
2. Remove screw from left side of C181-3 bearing housing. Screw may be covered by Telatemp; remove Telatemp as required to access screw. It is not necessary to replace Telatemp. Note: aft cowling may be removed to ease bearing access.
3. Using syringe, inject grease through screw hole.
4. Install B289-3 self-sealing cross-head screw, or thoroughly clean set screw and screw hole threads and then install set screw using B270-20 sealant, wet epoxy primer, or wet zinc-chromate primer on threads. Tighten set screw only until screw is flush with bearing housing.

CAUTION

Set screw hole is through to bearing housing cavity. Tightening set screw further than flush-with-housing can result in set screw contacting and damaging internal bearing assembly components.

5. Ground run helicopter at 102% RPM for two minutes, shut down, inspect bearing, and clean off any escaped grease.
6. Install aft cowling, if removed.

1.150 Defueling**WARNING**

Defueling must be done in a well-ventilated area. No smoking within 100 feet of helicopter during defueling.

NOTE

Low-fuel sender check (see Section 12.270) may be performed when defueling helicopter.

1. Turn fuel valve off and disconnect flexible fuel line at carburetor.
2. Place end of fuel line in a suitable container. Ground container to helicopter and turn fuel valve on.
3. Turn fuel valve off when the container is full and repeat as necessary to complete draining.
4. Attach fuel line to carburetor, torque per Section 1.330, and torque stripe.

1.160 Storage

For long-term (greater than 30 days) storage:

1. Defuel aircraft per Section 1.150.
2. Clean aircraft per Section 8 of R44 Pilot's Operating Handbook.
3. Paint or wax bare metal areas of main and tail rotor blades.
4. Apply suitable non-drying corrosion preventative compound to C166 clutch shaft adjacent to seals (where shaft enters and exits upper sheave).
5. Preserve engine in accordance with Lycoming Service Letter L180 (current revision).
6. Remove battery and periodically check and adjust, as required, battery charge status. Check fluid level and specific gravity of non-sealed batteries.
7. Store aircraft in a protected, dry (dehumidified) environment.
8. Periodically inspect aircraft for corrosion and correct as required.

1.170 Hydraulic Reservoir Filter Replacement

CAUTION

Cleanliness of hydraulic fluid is vital to proper system operation. Use only clean fluid from sealed containers and avoid contamination from dirty funnels, tubing, etc.

1. Remove and discard safety wire from filter cap. Remove filter cap from bottom of hydraulic reservoir.
2. Remove filter and examine. If debris is found, use a magnet to determine if ferrous or non-ferrous.

NOTE

Ferrous debris may indicate pump damage. Replace filter again after one flight hour. If more ferrous debris is found, replace hydraulic pump per Section 8 and flush hydraulic system per Section 1.180.

3. Clean filter cap and replace O-ring packing. Lubricate new O-ring with A257-15 fluid (see Section 1.470).
4. Lubricate O-ring in new filter with A257-15 fluid and install filter in reservoir. Install filter cap, torque per Section 1.330, and safety wire.
5. Adjust reservoir fluid level as required. Install filler-vent and torque per Section 1.330. Safety wiring filler-vent is not required.

1.180 Draining and Flushing Hydraulic System (see Figure 8-1A)**CAUTION**

Cleanliness of hydraulic fluid is vital to proper system operation. Use only clean fluid from sealed containers and avoid contamination from dirty funnels, tubing, etc.

NOTE

Drain and flush hydraulic system if oil turns dark, or emits bad odor.

1. Remove reservoir filler-vent.
2. Place a one-liter container for contaminated fluid beneath D500-1 hydraulic pump at main rotor gearbox. Remove caps from pump suction and pressure T-fittings. Allow fluid in reservoir to drain through suction line into container. Pour small amount of clean A257-15 fluid (see Section 1.470) into reservoir to purge suction line. Pressure line will drain in following step when filter cap is removed.
3. Replace hydraulic reservoir filter per Section 1.170.
4. See Figure 1-2A. Connect MT384 (or similar) 0.8-1.2 gpm hydraulic test pump to T-fittings on D500-1 pump. Fittings are different sizes to ensure correct connection.
5. Dispose of drained, contaminated hydraulic fluid. Fill reservoir with A257-15 fluid.
6. Disconnect servo return line at reservoir forward elbow and place end in empty container for contaminated hydraulic fluid. Cap elbow on reservoir assembly (use cap from pump T-fitting).
7. Activate hydraulic test pump and inspect hydraulic system for leakage.
8. Simultaneously fully raise collective and move cyclic fully forward. Then simultaneously fully lower collective and move cyclic fully aft. Monitor reservoir fluid level and fill as required. Repeat procedure until return line fluid into container is clean.

WARNING

Stay clear of moving flight controls. Hydraulic forces can cause injury.

9. Simultaneously fully raise collective and move cyclic fully aft then simultaneously fully lower collective and move cyclic fully forward. Monitor reservoir fluid level and fill as required. Repeat procedure until return line fluid into container is clean.
10. Connect servo return line to reservoir forward elbow. Torque B-nut per Section 1.330 and torque stripe.
11. Bleed hydraulic system per Section 1.190.
12. Remove and inspect filter. If debris is found, repeat drain and flush procedure. If filter is clean, reinstall per Section 1.170, steps 4 & 5.

1.190 Bleeding Hydraulic System (see Figure 1-2A)

1. Disconnect cap on D500-1 hydraulic pump pressure (aft) T-fitting and connect pressure line from MT384 hydraulic test pump (or similar 0.8-1.2 gpm unit). Pressure and suction fittings are different sizes to assure correct connection.
2. Remove reservoir filler-vent and cover hole with finger to prevent fluid loss. Disconnect cap on hydraulic pump suction (forward) T-fitting and connect hydraulic test pump suction line. Fill reservoir as required.
3. Activate hydraulic test pump and inspect for leakage.
4. Simultaneously fully raise collective and move cyclic fully forward then simultaneously fully lower collective and move cyclic fully aft. Repeat procedure ten times.

WARNING

Stay clear of moving flight controls. Hydraulic forces can cause injury.

5. Simultaneously fully raise collective and move cyclic fully aft then simultaneously fully lower collective and move cyclic fully forward. Repeat procedure ten times.
6. Shut off hydraulic test pump. Verify no leaks in hydraulic system.
7. Cover reservoir filler-vent hole with finger to prevent fluid loss. Disconnect hydraulic test pump suction line from D500-1 pump forward T-fitting and install cap. Torque cap per Section 1.330 and torque stripe.
8. Disconnect hydraulic test pump pressure line from D500-1 pump aft T-fitting and install cap. Torque cap per Section 1.330 and torque stripe.
9. Adjust reservoir fluid level as required. Install filler-vent and torque per Section 1.330. Safety wire is not required.

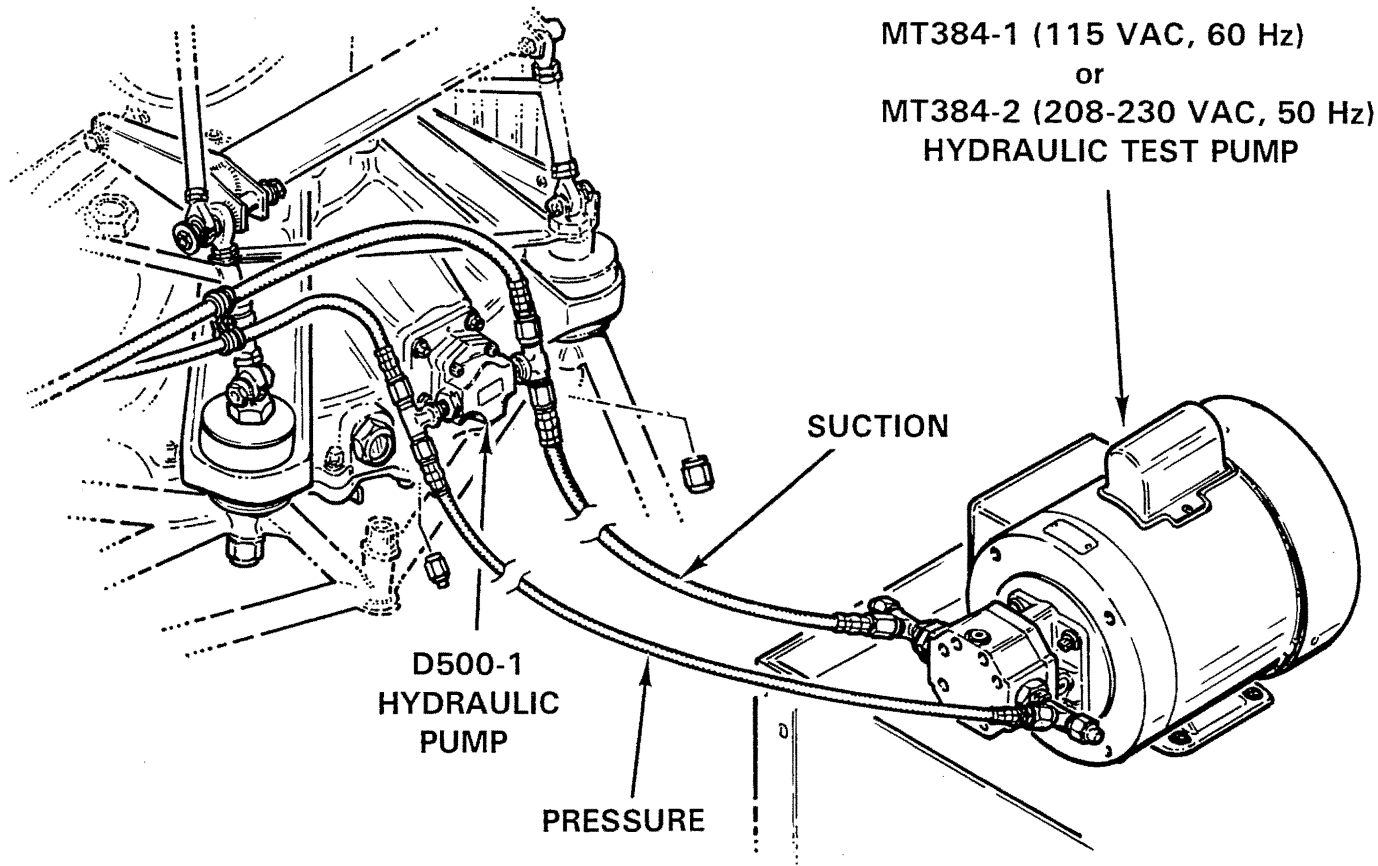

FIGURE 1-2A

MT384 HYDRAULIC TEST PUMP CONNECTION

Intentionally Blank

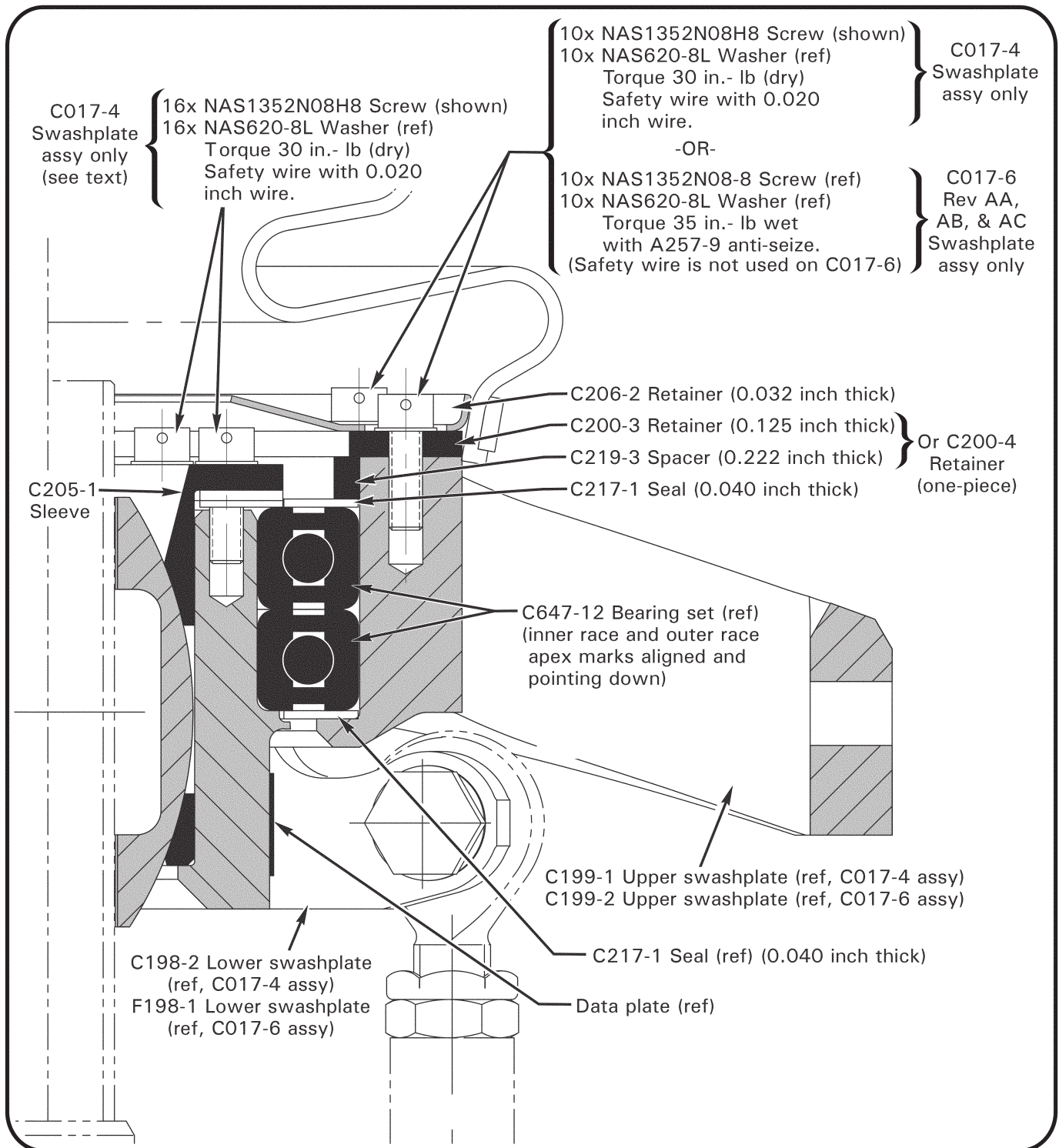

FIGURE 1-2B C017-4 SWASHPLATE ASSEMBLY, AND C017-6 REV AA, AB, & AC SWASHPLATE ASSEMBLY, APPROVED B900-13 MODIFICATION

1.195 Lubrication of Swashplate Bearings

1. a. If swashplate is P/N C017-6 Rev AD or subsequent, proceed to step 2.
b. If swashplate is P/N C017-4, or is P/N C017-6 Rev AA, AB, or AC, AND
— “B900-13 MOD” is marked adjacent to swashplate data plate, proceed to step 2.
— “B900-13 MOD” is NOT marked adjacent to swashplate data plate, install upper C217-1 seal in accordance with R44 Service Letter SL-76A.
2. Remove ty-rap securing C480 boot to upper (rotating) swashplate.
3. Remove hardware securing lower rod ends of both C258 pitch links to upper swashplate. Temporarily secure boot, upper A205 fork, and both pitch links up & away from swashplate.
4. Rotate upper swashplate by hand; if bearing roughness is detected, replace swashplate or submit swashplate to RHC for repair.
5. Refer to Figure 1-2B. Remove (10) NAS1352 screws (with washers) securing C206-2 & C200-3 retainers to upper swashplate. Raise both retainers and C219-3 spacer and either temporarily secure to chord arm (if on helicopter) or set aside (if on workbench).
6. Using a 0.006 inch feeler gage, gently pry up outer edge of upper C217-1 seal and expose top ball bearing.
7. Using a syringe or grease gun, add A257-3 grease into cavity above bearing set until grease is just below top of C205-1 sleeve (approx. 20 ml grease). Do not allow grease into screw holes.
8. Position C217-1 seal atop grease followed by C219-3 spacer, C200-3 retainer, and NAS1352N08-8 screws with NAS620-8L washers. Finger-tighten all screws, then snug any (4) screws that are 90° apart, depressing seal and forcing grease into underlying bearing set. Rotate upper swashplate several revolutions. Wipe off excess grease.
9. Repeat steps 5 thru 8 once, then proceed to step 10.
10. Remove screws & washers and solvent-clean. Raise and clean C200-3 retainer and C219-3 spacer, then reinstall both.
11. Install C206-2 retainer, NAS620-8L washers, and NAS1352N08-8 screws with A257-9 anti-seize. Special torque screws per § 23-33.
12. Connect upper A205 fork rod end and lower rod end of associated C258 pitch link, to interrupter-side swashplate ear; standard torque bolt per § 23-32. Install palnut, standard torque per § 23-32, and torque stripe per Figure 2-1.
13. Attach two A255-3 counterweights, and lower rod end of C258 pitch link, to swashplate ear opposite interrupter; standard torque bolt per § 23-32. Install palnut, standard torque per § 23-32, and torque stripe per Figure 2-1.
14. Verify safety washers (or counterweight) and C115 spacers installed at all rod ends per Figure 2-1.

1.195 Lubrication of Swashplate Bearings (continued)**WARNING**

Assembly of flight controls is critical and requires inspection by a qualified person. If a second person is not available, the installer must take a 5-minute break prior to inspecting flight control connections he has assembled.

15. Connect hydraulic test pump as described in § 1.190.
16. Activate test pump. While observing swashplate, have someone fully manipulate cyclic and collective controls. Verify swashplate movement corresponds with cyclic and collective movement, and without interference. With collective full-up, ensure ball is at dimension shown in Figure 10-2.
17. Shut off hydraulic test pump. Disconnect hydraulic test pump as described in § 1.190.
18. Position swashplate boot on upper swashplate and secure with MS3367-6-0 ty-rap.
19. With appropriately rated person at controls, start helicopter, run up to 102% rotor RPM, then shutdown.
20. Remove ty-rap, and raise swashplate boot. Wipe off excess grease from swashplate. Position swashplate boot on upper swashplate and secure with MS3367-6-0 ty-rap.

1.200 HANDLING, JACKING, HOISTING, LEVELING, AND WEIGHING**1.210 Ground Handling****1.211 Ground Handling Wheels Installation**

- a) Extend the handle by depressing the handle locking pin and sliding the handle out until the pin snaps into the outer hole. Hold handle and wheel with the protruding spindle in its lowest position. Insert spindle into support mounted on skid (see Figure 1-3).

NOTE

If helicopter has not settled on its skids completely, the spindles may not go in all the way. In this case, pull down on the tail cone to spread the gear enough to allow installation.

- b) Make sure that the protruding spindle is all the way in with the widened end completely past the inside of the support (see Figure 1-3A).
- c) Pull handle over center to raise helicopter and lock wheel in position (see Figure 1-4).

CAUTION

When lowering the helicopter, the handle has a tendency to snap over.

NOTE

70 psi maximum tire inflation pressure.

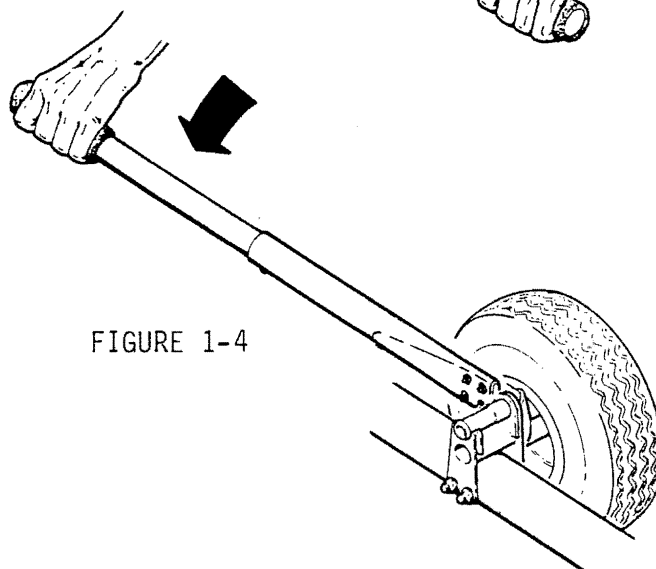
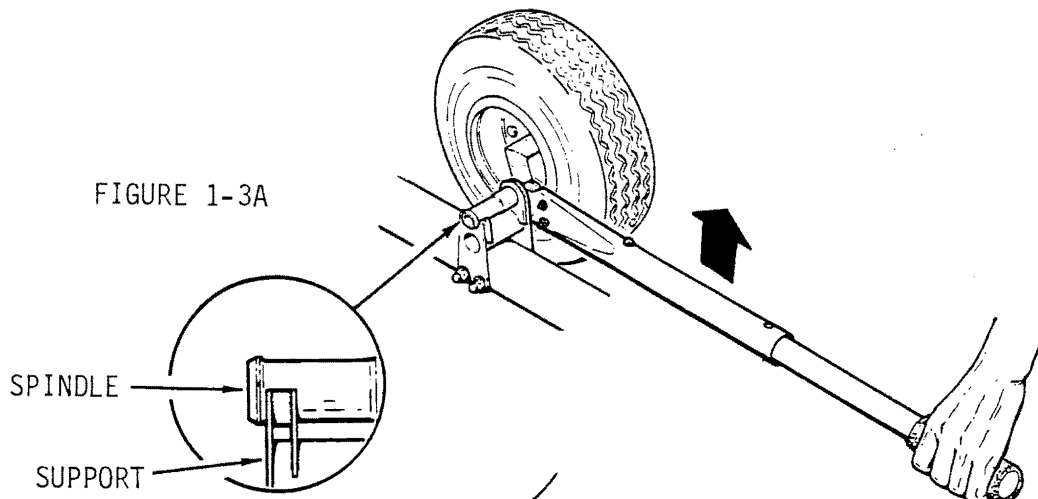
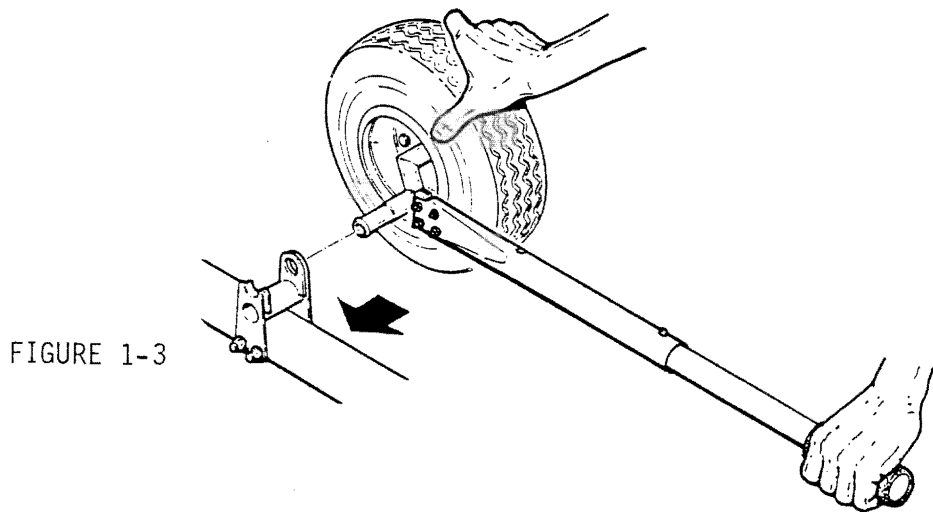

1.210 Ground Handling (cont'd)

1.212 Ground Handling Wheels - Float Ship Landing Gear

INSTALLATION:

Align aft blocks adjacent to mark on skid tube and position forward blocks to remove cord slack.

- a) Pull tail down. Insert forward blocks at their lower height under both skids.

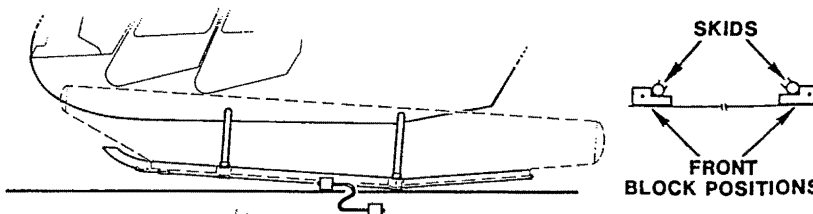

- b) Push tail up. Insert rear blocks at their lower height under both skids at marks.

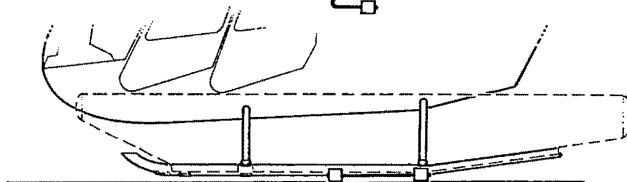

- c) Pull tail down. Move forward blocks inward to their upper height under skid tubes.

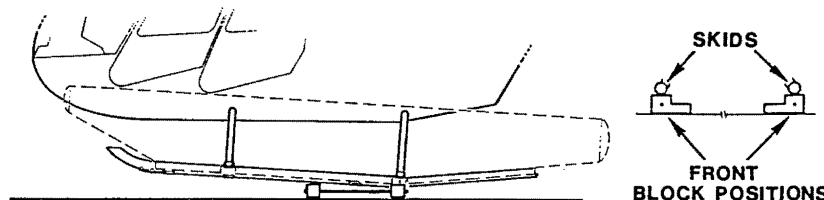

- d) Push tail up. Slide rear blocks out (upper height of rear blocks is not used) and insert wheels under skids at rear marks.

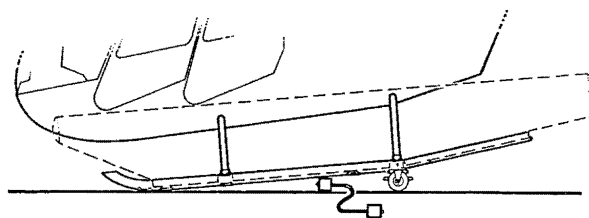

NOTE

Wheels may be placed a few inches forward to reduce force required to pull tail down.

- e) Pull tail down and remove forward blocks.

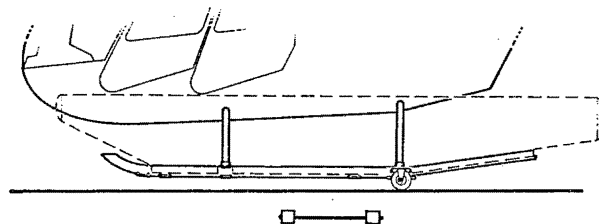
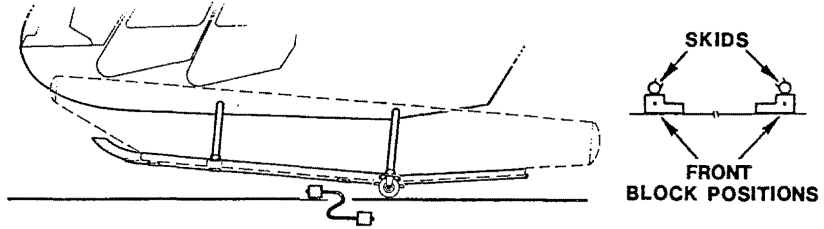

FIGURE 1-3B FLOAT SHIP GROUND HANDLING WHEELS INSTALLATION

1.212 Ground Handling Wheels - Float Ship Landing Gear (cont'd)

REMOVAL:

- a) Pull tail down. Insert forward blocks at their upper height at forward marks under skids.



- b) Push tail up. Remove wheels and insert rear blocks at their lower height (upper height on rear blocks is not used) at marks.

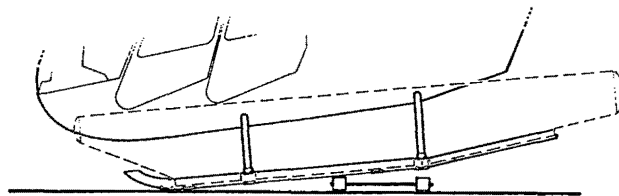

- c) Pull tail down. Position forward blocks under skids at their lower height.

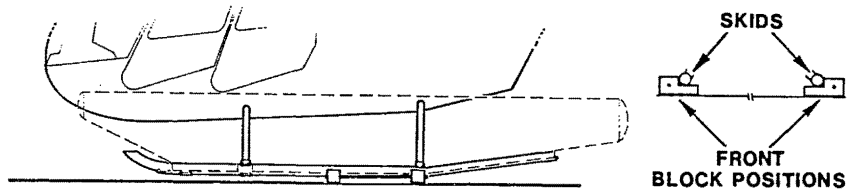

- d) Push tail up. Remove rear blocks.

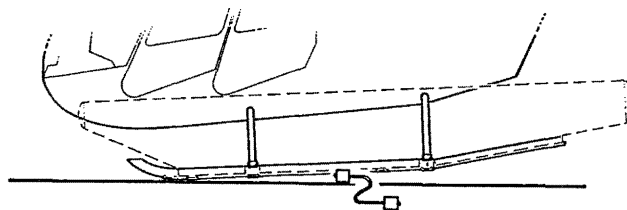

- e) Pull tail down. Remove front blocks.

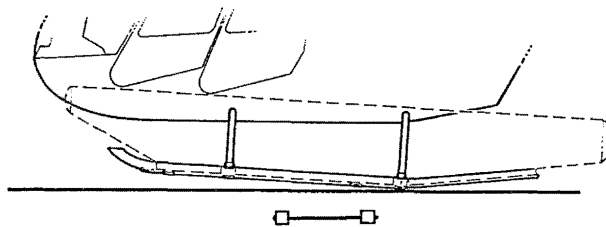

FIGURE 1-3C FLOAT SHIP GROUND WHEELS REMOVAL

1.213 Moving the Helicopter on Ground Handling Wheels

Moving the helicopter on ground handling wheels requires two people: one person to hold the tail down and steer by holding the tail rotor gearbox and another person to push on primary structure. The steel tube frame inside the aft cowl door may be used as a hand hold for pushing. Keep feet clear of skid tubes during ground handling.

CAUTION

Do not move helicopter by gripping tail rotor guard, outboard portion of horizontal stabilizer, tail rotor, or tail rotor controls.

1.214 Main Rotor Blade Tie-Downs

Install MT290-2 main rotor blade tie-downs as shown in Figure 1-5. Tie-down straps are installed by removing slack from lines to prevent blade movement.

CAUTION

Overtightening tie-down straps can damage main rotor blades.

1.215 Parking

Refer to Section 8 of the R44 Pilot's Operating Handbook for parking procedures.

1.216 Trailing

Trailing the R44 is not normally recommended. Most trailers large enough to accommodate the helicopter are designed for much heavier loads; the trailer's springs and shock absorbers will not function properly when lightly-loaded. If trailing is unavoidable the following precautions should be observed:

1. Load trailer with ballast until it is at the average weight it is designed to carry.
2. Support tailcone, taking care to prevent chafing or abrasion at the support point.
3. Remove main rotor blades. If not practical to remove, support the main rotor blades so they will not bear on droop stops. Locate supports about 5 feet in from blade tips. Supports must be cushioned to prevent blade damage.
4. Restrain tail rotor to prevent teetering.

DETAIL - TIE AROUND THE BRACKET ABOVE THE CABIN AIR INLET.

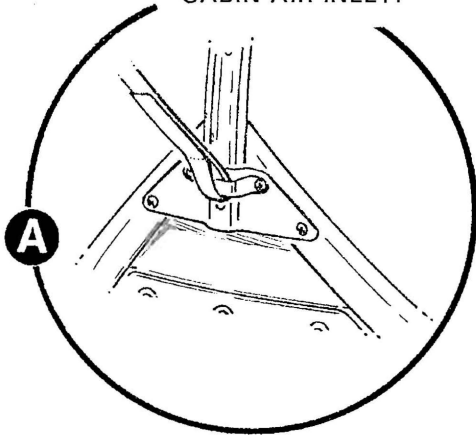

CAUTION
Overtightening Tie-Down straps can damage blades.

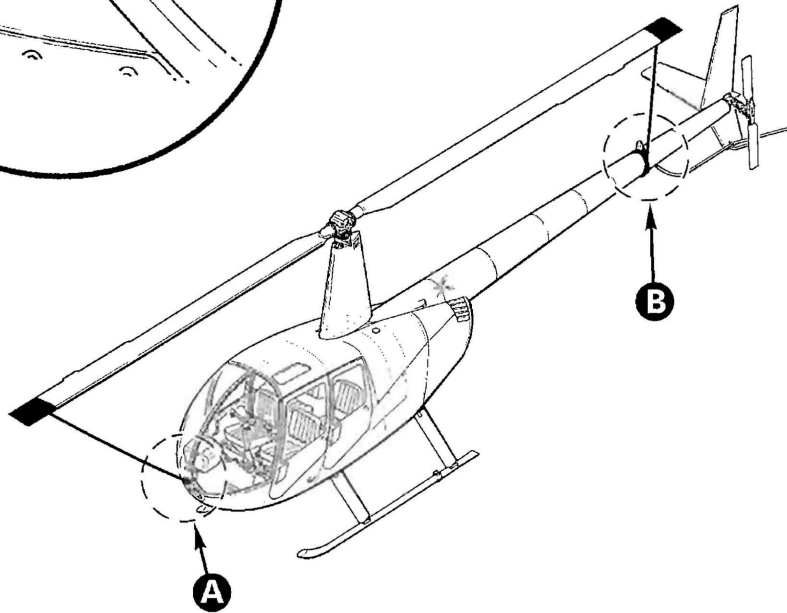

WRAP AROUND TAIL CONE IN FRONT OF LIGHT, AROUND TAIL CONE TO BACK OF LIGHT; THEN WRAP AROUND BASE TO ATTACH VELCRO.

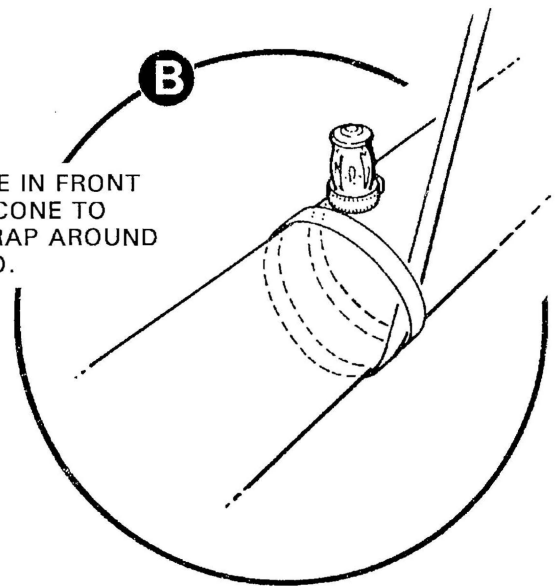

FIGURE 1-5 MAIN ROTOR BLADE TIE-DOWN INSTALLATION

1.216 Trailering (continued)

- e. Protect helicopter windshield, tail rotor, and other vulnerable parts from highway debris damage.
- f. After trailering, thoroughly inspect aircraft for possible damage, with particular attention to the steel tube structure and rotor systems.

1.220 Jacking, Hoisting, and Leveling

This section has been moved to Chapter 17 Jacking and Hoisting, and Chapter 18 Weight and Balance (includes leveling).

1.230 Weighing and CG Calculation

This section has been moved to Chapter 18 Weight and Balance.

1.240 Fixed Ballast Installation

This section has been moved to Chapter 18 Weight and Balance.

1.300 Fastener Torque Requirements

Fastener torque requirement information has been moved to Chapter 23.

Standard torques, previously located in § 1.320, are now located in § 23-32.

Special torques, previously located in § 1.330, are now located in § 23-33.

1.400 Approved Materials

Approval materials information has been moved to Chapter 23.

1.500 (Reserved)

1.600 Part Interchangeability

Refer to R44 Illustrated Parts Catalog for part interchangeability information (ref. § 23-81).

1.700 Assembly Instructions for R44-series Helicopter Crated for Export**A. Assembly****NOTE**

Aircraft assembly to be performed by a certificated mechanic.

1. Remove top of cabin assembly crate. Remove wall marked "A" by removing lag bolts painted black. Remove empennage assembly. Remove remaining walls. Remove all parts, except cabin assembly, from crate base. Open crate containing blades, skid tubes, and tailcone. Open F050-2 horizontal stabilizer box, if applicable.
2. Reinstall main rotor hub per § 28-20.
3. Assemble landing gear per applicable sections in Chapter 5.

NOTE

Do not install strut fairings at this time.

4. Attach a hoist to main rotor hub per § 17-20. Lift aft end of crate while at same time taking up slack in hoist. When helicopter belly is in a horizontal position, lift with hoist until cabin is supported by hoist alone. Remove lag screws and carriage bolts attaching helicopter cabin to crate. Remove crate.

CAUTION

Do not lift helicopter and attached crate using main rotor hub; damage to main rotor gearbox and frames could result.

5. Remove supports from landing gear attachment points and install assembled landing gear per § 5.120 or Chapter 5 (float landing gear). Install front cross tube cover panel. If desired, install strut fairings per § 5.420 (not applicable to utility float landing gear).
6. Remove tailcone cowling and install tailcone per § 4.300. Install strobe light. Install communication, Loran, and GPS antennas (if equipped). Install tailcone cowling.

CAUTION

Make sure all foam packing material is removed from inside of tailcone before installation; damage to tail rotor drive shaft could result.

7. Install F050-2 horizontal stabilizer per § 4.500, if applicable. Install empennage assembly per § 4.600. Install tail rotor guard per § 4.400.
8. Fill tail gearbox to center of sight gage using correct gearbox oil (refer to R44 Service Letter SL-73). Rotate rotor system by hand for several revolutions. Check gearbox oil level and adjust as required; install filler-plug and special torque per § 23-33.

1.700 Assembly Instructions for R44-series Helicopter Crated for Export (continued)**A. Assembly (continued)**

9. Install tail rotor per § 30-10. Match color coded markings on blades with pitch links.
10. Install fan and scroll per § 6.220.
11. Install engine exhaust per § 6.520.
12. Install main rotor blades per § 28-10. Match color-coded markings on blades with markings on hub and pitch links.
13. Perform tail rotor drive shaft runout per § 7.340.
14. Fill main gearbox to center of sight gage using correct gearbox oil (refer to R44 Service Letter SL-73). Rotate rotor system by hand for several revolutions. Check gearbox oil level and adjust as required; install filler-plug and special torque per § 23-33.
15. Fuel helicopter and drain a small amount of fuel through gascolator.
16. If ship is equipped with attitude horizon, directional gyro, turn coordinator, and/or vertical card magnetic compass, install as follows:

Attitude Horizon, Direction Gyro, and Turn Coordinator:

Remove warning lights from lower console. Pull out B197 instrument face by removing six (6) securing screws.

NOTE

Place a piece of foam under B197-1 face to prevent scratching lower face.

Install required instrument(s) by securing with hardware provided.

CAUTION

Directional gyro mount screws must not exceed 1 inch in length or unit will be damaged.

Connect existing straight connector(s) to directional gyro and/or turn coordinator. Connect angle connector to attitude horizon, ensuring strain relief points down. Ensure connectors lock in place. Ty-rap excess wiring. Reinstall B197-1 face to console. Reinstall amber FUEL FILTER (IO-540 only), AUX FUEL PUMP (IO-540 only), ALT, & GOV OFF lights and red ENG FIRE & OIL warning lights.

Vertical Card Magnetic Compass:

Remove vertical card compass from foam-protected box. Install a 2-inch length of B158-3 heat-shrink tubing over each compass wiring pin. Locate existing wires from windshield center bow. Connect pins from compass to existing sockets (polarity is not critical), cover connection with heat-shrink, then apply heat. Secure compass in mount with four screws and hide and secure wiring atop compass.

1.700 Assembly Instructions for R44-series Helicopter Crated for Export (continued)**A. Assembly (continued)**

17. Install battery (negative ground system) per § 37-10.
18. Remove plastic dehydrator plugs from each cylinder's upper spark plug hole.
19. Lubricate provided upper spark plugs threads with A257-16 oil, install, and torque per § 23-33.
20. Connect ignition leads to upper spark plugs and install spark plug access covers.
21. Disconnect ignition leads from lower spark plugs and remove lower spark plugs.
22. Place a small container under each cylinder's lower spark plug hole. With ignition switch in the OFF position, rotate engine by hand, several revolutions, to force excess preservation oil from cylinders.
23. Temporarily connect a grounding wire from each magneto's primary lead terminal to airframe ground.
24. Activate starter for no more than 12 seconds or until oil pressure is indicated on gage, whichever comes first. Allow starter to cool for 5 minutes after each activation.
25. After oil pressure is indicated remove temporary grounding wire from each magneto.
26. Lubricate lower spark plug threads with A257-16 oil, install, and torque per § 23-33.
27. Connect ignition leads to lower spark plugs.
28. Install belly, left, right, and aft cowling assemblies.
29. Perform § 2.205 ground check.
30. Perform § 2.210 run-up.

NOTE

Idle rpm and mixture were set for sea-level standard conditions during factory flight test. Adjust idle if idle and off-idle throttle performance are not satisfactory upon reassembly.

31. Perform flight checks per Part B.

1.700 Assembly Instructions for R44-series Helicopter Crated for Export (continued)**B. Flight Checks**

NOTE

Flight checks to be performed by a qualified pilot and certificated mechanic.

1. Perform preflight inspection per the applicable Pilot's Operating Handbook.
2. Balance fanwheel per § 6.240.
3. Balance tail rotor per § 10.240.
4. Perform hover checks per § 2.220 Step 1. DO NOT proceed into forward flight at this time.
5. Track and balance main rotor per § 10.200.
6. After completing track and balance, adjust autorotation RPM per § 10.250. Avoid rotor overspeeds by avoiding higher gross weights and higher altitudes during autorotation checks.
7. While climbing at Maximum Continuous Power (MCP), 60 KIAS, and governor on:
 - a. Evaluate roughness and controllability.
 - b. Perform 30 degree left yaw to check for adequate directional control.
8. Level flight at typical cruise altitude (deviate as required for weather and terrain), MCP, and governor on, evaluate the following:
 - a. Longitudinal and lateral cyclic control forces.
 - b. Collective control forces.
9. Evaluate roughness at MCP and straight & level flight.
10. Check all instruments, gauges, and avionics for proper operation.
11. During autorotation at 50 KIAS and 90% RPM, perform a 30 degree right yaw to check for adequate directional control.

Intentionally Blank

CHAPTER 2
INSPECTION

<u>Section</u>	<u>Title</u>	<u>Page</u>
2.000	Introduction	2.1
2.100	General Procedures	2.1
2.110	Ball and Roller Bearings	2.1
2.120	Push-Pull Tubes, Rod Ends, and Spherical Bearings	2.3
2.121	Push-Pull Tubes	2.3
2.122	Rod Ends and Spherical Bearings	2.3
2.125	Elastomeric Bearings	2.5
2.130	Telatemp Indicators	2.6
2.140	Torque Stripes	2.6
2.200	Ground and Flight Check For 100-Hour/Annual Inspection	2.7
2.205	Ground Check	2.7
2.210	Run Up	2.9
2.220	Flight Check	2.11
2.230	Shutdown	2.11
2.300	Airframe Preparation For 100-Hour/Annual Inspection	2.13
2.400	100-Hour/Annual Airframe Inspection	2.13
2.410	Inspection Procedures and Checklist	2.13
2.500	Special Inspections	2.39
2.501	Upper and Lower Clutch Actuator Bearings Inspection	2.39
2.502	C181 Lower Bearing Inspection	2.39
2.503	C184 Upper Bearing Inspection	2.40
2.507	V-Belt Inspection	2.41
2.508	Lower Sheave V-Belt Wear Pattern Inspection	2.43
2.510	Tail Skid Strike	2.45
2.520	Tail Rotor Strike	2.48
2.530	Main Rotor Strike	2.49
2.540	Rotor/Engine Overspeed	2.50
2.550	Hard Landing	2.51
2.560	[Reserved.]	2.54
2.561	Corrosion on C020 Upper Steel Tube Frame	2.54
2.570	Volcanic Ash Recommendations	2.55
2.580	Windshield Inspection	2.57
2.590	Lightning Strike	2.58
2.595	Inspection After Stabilizer Damage	2.59

CHAPTER 2

INSPECTION (Continued)

<u>Section</u>	<u>Title</u>	<u>Page</u>
2.600	2200-Hour/2400-Hour/12-Year Inspection	2.60
2.610	Tail Rotor Gearbox 12-Year Maintenance	2.62
2.620	Fanwheel 12-Year Maintenance	2.63
2.630	C258-5 Main Rotor Pitch Link Assembly Inspection	2.64
2.640	Swashplate Assembly 12-Year Inspection	2.65
2.650	Landing Gear Assembly Inspection	2.66
2.660	Hydraulic Reservoir 12-Year Inspection	2.67

CHAPTER 2

INSPECTION

2.000 Introduction

The R44 helicopter must be inspected periodically to verify it is in airworthy condition. Required inspection intervals are maximum 100 hours time in service or 12 calendar months (annually), whichever occurs first; the inspection interval may be extended up to 10 hours, without accumulation, if allowed by local regulations. Fluid leaks, discoloration, dents, scratches, nicks, cracks, galling, chafing, fretting, and corrosion all warrant further investigation. Unairworthy items must be replaced or repaired as allowed by Robinson Helicopter Company. This section contains procedures for performing the required periodic airframe inspections.

2.100 General Procedures

Refer to U.S. FAA AC 43.13-1B Chapter 5 Section 2 for Visual Inspection guidance, and Chapter 11 Section 8 paragraph 11-97 for Wiring Replacement guidance. When required, magnetic particle inspection may be performed in accordance with ASTM E 1444 and MIL-STD-1907. Fluorescent penetrant inspection may be performed in accordance with ASTM E 1417 and MIL-STD-1907. For following components, use accompanying inspection criteria unless otherwise specified.

2.110 Ball and Roller Bearings

The first indication of bearing failure is usually an increase in bearing noise. Noise will almost always start several hours before bearing failure or any increase in bearing temperature. Listen to drive system during start-up and shutdown. A failing bearing will produce a loud whine, rumble, growl, or siren sound. Upon hearing an unusual noise, thoroughly inspect all bearings before further flight. A failing bearing may have a distorted seal or be exuding a large amount of grease. Do not rely on Telatemps to detect failing bearings as temperature increase may occur only seconds before bearing disintegrates. Refer to § 2.501.

The failure of either actuator bearing in flight could cause loss of power to the rotor system and could result in a serious accident. The actuator upper roller bearing is on the clutch shaft aft of the upper sheave; the actuator lower roller bearing is on the fanshaft aft of the lower sheave. Just before complete failure of an actuator bearing, the clutch light may flicker constantly (on and off in less than one second). This should not be confused with its normal on-off retensioning in flight (on for 1-8 seconds then off). Flight should not be resumed until cause of the flickering clutch light has been determined.

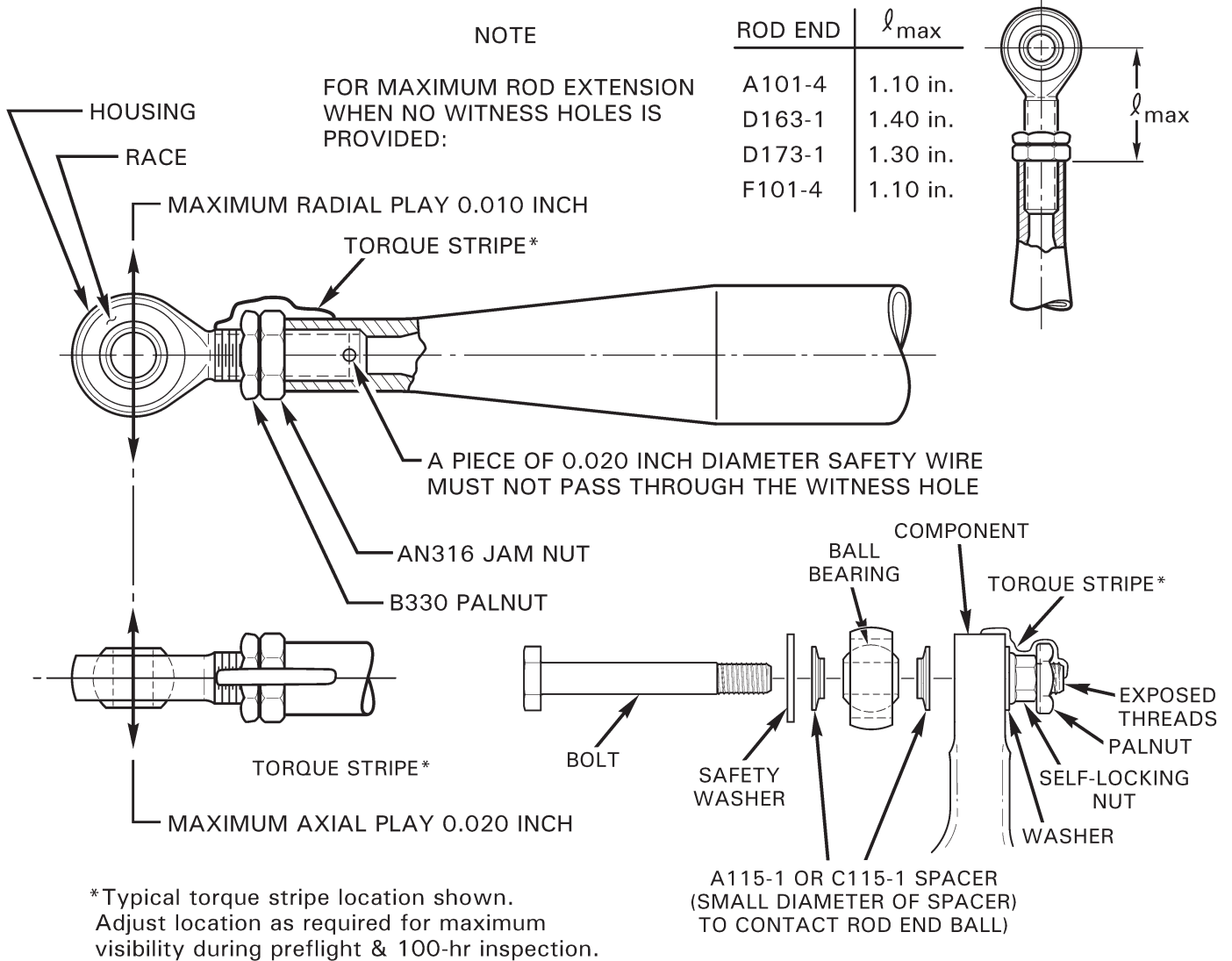

FIGURE 2-1 ROD END AND SPHERICAL BEARING PLAY LIMITS AND TORQUE STRIPE APPLICATION

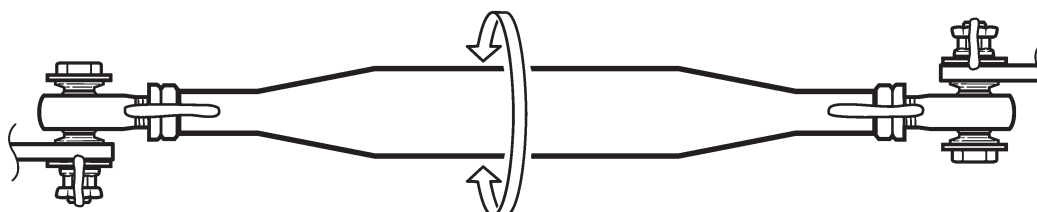

FIGURE 2-1A ROD END CENTERING
(Position rod ends for maximum rotation)

2.120 Push-Pull Tubes, Rod Ends, and Spherical Bearings

2.121 Push-Pull Tubes

1. Nicks, cuts, or scratches in tube not more than 0.010 inch deep and not more than 1/4 of tube circumference may be polished out in lengthwise direction using 320-grit or finer wet-or-dry abrasive paper to 1-inch minimum blend radius. Replace push-pull tube if depth exceeds these limits.
2. Replace push-pull tube if tube is dented or flattened more than 5% of its diameter in unswaged area; dents or flattening is not permitted in swaged (tapered and threaded) ends of tubes.

2.122 Rod Ends and Spherical Bearings

Refer to Figures 2-1 & 2-1A.

1. Maximum axial play: 0.020 inch (for A104-4 bearing only: 0.035 inch axial play)
Maximum radial play: 0.010 inch
2. Looseness between spherical bearing outer race & rod end housing, or between spherical bearing outer race & part, is not permitted.
3. Rod ends not riveted in place must block passage of 0.020-inch diameter wire through witness hole. Refer to Figure 2-1 for maximum rod end extension when no witness hole is provided.
4. Rod end jam nuts and palnuts must be torqued per § 23-32 and torque striped per Figure 2-1 at the most visible position for pre-flight inspection. Torque stripe must extend across nuts to both rod end shank and push-pull tube (or pitch link barrel, yoke, support, strut, etc.). Torque stripes are subject to deterioration and must be periodically renewed.
5. Refer to Figure 2-1A. Rod ends must be positioned (centered) to allow as much push-pull tube or link rotational movement as possible without binding.

CAUTION

Teflon-lined bearings must not be lubricated or solvent cleaned.

WARNING

Assembly of flight controls is critical and requires inspection by a qualified person. If a second person is not available, RHC recommends the installer take a 5-minute break prior to inspecting flight control connections the installer has assembled.

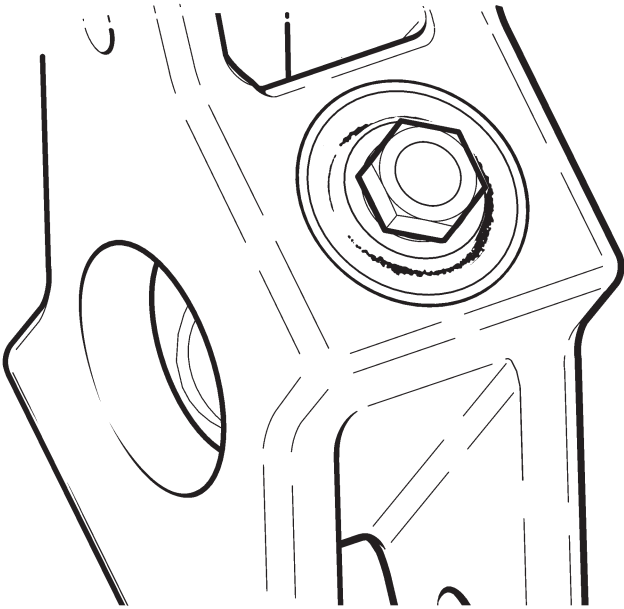

FIGURE 2-2A
ELASTOMER FATIGUE

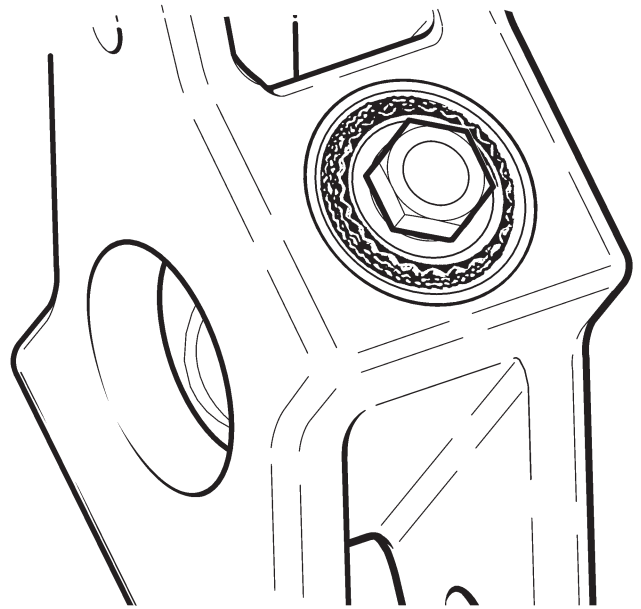

FIGURE 2-2B
ELASTOMER OIL CONTAMINATION

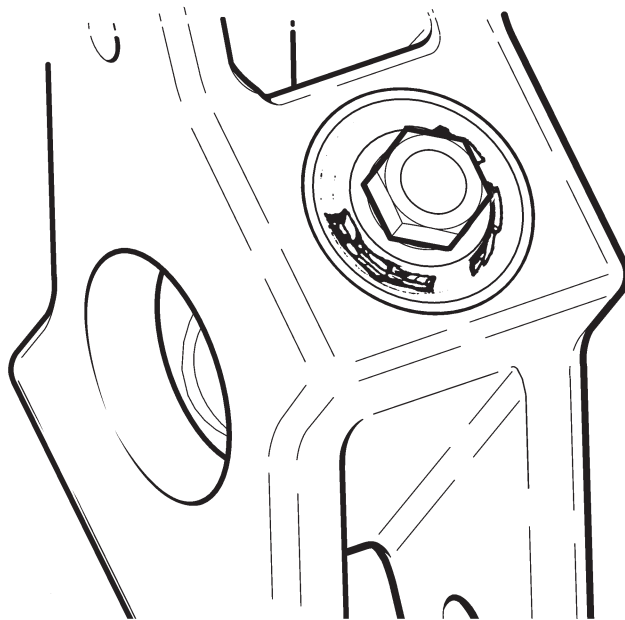

FIGURE 2-2C
ELASTOMER OVERLOAD

2.125 Elastomeric Bearings

Elastomeric bearings are used in the D062-1 tail rotor hub assembly. Fatigue, oil contamination, or overload can degrade the elastomer.

Small surface cracks (fatigue cracks) and elastomer dust or “eraser crumbs” (see Figure 2-2A) are normal and are not cause for replacement. As cracks grow, enough elastomer will be lost to cause reduced stiffness and increased vibration. If deep (greater than 0.10 inch) cracks are present over more than 25% of elastomer face, replace bearing.

Avoid exposure to oil, grease, hydraulic fluid, cleaning solvent, and rust-preventative fluids. Immediately wash off any such contaminants with detergent and water. Contaminated bearings exhibit swelling, wavy edges, or debonding (see Figure 2-2B) and must be replaced.

Overload occurs when elastomer’s tensile strength or rubber-to-metal bond strength is exceeded. This can occur when normal loads are applied to a bearing weakened by fatigue or oil contamination. Overload is indicated by large extrusions from and large clean cracks in elastomer as shown in Figure 2-2C.

Elastomer may also separate (debond) from metal bushings. If separation occurs over more than 25% of bonded area, replace bearing.

2.130 Telatemp Indicators

Refer to Figure 2-3. Self-adhesive Telatemp indicators record changes in operating temperatures of bearings and gearboxes. To use a Telatemp, draw a reference line between the highest temperature square which has darkened during normal operation and the next undarkened square. During every check thereafter, determine if an additional square has blackened. If an indicated temperature increase cannot be accounted for by a change in operating conditions, carefully examine the component before further flight.

NOTE

Telatemps can indicate erroneously if contaminated by a petroleum product, typically appearing as white, unactivated square(s) between darkened squares at each end; replace any Telatemp indicating as such and clean area with acetone prior to installing.

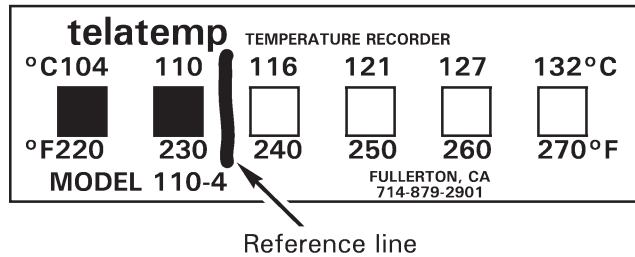

FIGURE 2-3 TELATEMP INDICATOR WITH DRAWN REFERENCE LINE

Part Number	Temperature Range
F110-2	60°C / 140°F — 88°C / 190°F
F110-3	82°C / 180°F — 110°C / 230°F
F110-4	104°C / 220°F — 132°C / 270°F

2.140 Torque Stripes

If, during inspection, the remaining torque stripe on a fastener is insufficient to determine joint integrity, then remove accompanying palnut as required and apply specified torque to fastener. If fastener moves, disassemble joint and inspect parts for damage such as fretting, thread deformation, hole elongation, etc.; replace damaged parts. If fastener does not move, install new palnut as required & standard torque per § 1.320. Torque stripe fastener per Figure 2-1.

2.200 GROUND AND FLIGHT CHECK FOR 100-HOUR/ANNUAL INSPECTION

Complete following checklists in conjunction with a 100-hour or annual inspection. Note and correct any discrepancies.

2.205 Ground Check (Aircraft not running)

- 1. **Throttle Control:** Check for freedom of rotation with collective full down and full up. _____
- 2. **Throttle Overtravel Spring:** Check by twisting throttle past idle position to override stop. Release throttle and ensure it returns to normal idle position. _____
- 3. **Mixture Control:** Check for smoothness of operation with no binding. Check press-to-unlock button for proper function. Verify 0.03 to 0.10 inch spring-back at full rich position. _____
- 4. **Carburetor Heat Control (O-540 only):** Check for smoothness of operation with no binding. Verify 0.03 to 0.10 inch spring-back at full off position. _____
- 5. **Cyclic Control:** With trim motors (if installed) in neutral position, verify freedom thru full travel with friction off. Verify friction knob rotates 1/8-to-1 full turn before adding friction. For hydraulic controls: Verify approximately one-half inch total longitudinal and one inch total lateral freeplay before encountering resistance. Verify normal hydraulic resistance with no binding or abnormal feel throughout control travel. _____
- 6. **Collective Control:** Verify freedom through full travel with friction off and on. For non-hydraulic aircraft, verify friction knob moves 0.3-0.6 inch before adding friction. For hydraulic controls: Verify approximately one-half inch total freeplay before encountering resistance. With carb heat assist (if installed) locked and friction lever fully off, verify C334 friction (between rear seats) within freeplay range is 4-5 pounds average measured at grip. With friction lever fully on, verify 18-22 pounds measured at grip. Verify normal hydraulic resistance with no binding or abnormal feel throughout control travel. _____
- 7. **Carb Heat Assist (if installed):** With collective down and full carb heat, raise collective full up and verify carb heat off. Lower collective full down and verify carb heat full on. With collective friction off, push carb heat off and verify collective stays down. _____
- 8. **Tail Rotor Pedals:** Check for smooth operation with no binding. _____
- 9. **Removable Controls:** Verify security of attach fasteners. _____

2.205 Ground Check (cont'd)

10. Lighting and Instruments: (Master Switch on)

- a. CARBON MONOXIDE warning light flashes twice (if installed). _____
- b. Carb Air Temp approximately same as Outside Air Temp. _____
- c. ALT warning light on. _____
- d. OIL pressure warning light on. _____
- e. AUX FUEL PUMP warning light on (IO-540 only). _____
- f. Fuel quantity gages - indication of fuel level. _____
- g. Navigation and panel lights - check function. _____
- h. Strobe light - check function. _____
- i. Landing lights - check function (clutch switch must be engaged to check landing lights). _____
- j. Map light - check function. _____
- k. Ammeter - shows discharge. _____
- l. Oil temperature gage - slight needle deflection with engine cold. _____
- m. Cylinder head temp gage - slight needle deflection with engine cold. _____
- n. MR TEMP light - on when sender shorted or test switch depressed. _____
- o. MR CHIP light - on when sender shorted or test switch depressed. _____
- p. ENGINE FIRE light – on when sender shorted or test switch depressed. _____
- q. TR CHIP light - on when sender shorted or test switch depressed. _____
- r. LOW FUEL light - on (slight delay is normal) when low fuel sender in tank is depressed with clean, non-sparking rod or when test switch depressed. _____
- s. FUEL FILTER light – on when test switch depressed (IO-540 only). _____

11. Verify aircraft checklist laminated card is current revision (refer to Section 1.002). _____

2.210 Run Up

1. Perform POH Section 4 "Preflight" checklist. _____
2. Perform "Before Starting Engine" checklist. _____
3. IO-540 engine: Verify AUX FUEL PUMP light extinguishes during prime and illuminates after priming. Verify fuel drains from sniffle valve. _____

NOTE

Significant prime may be required before fuel drains from sniffle valve. Wait for valve to stop draining before starting engine. Engine will be hard starting/flooded while valve is draining.

4. Perform "Starting Engine and Run-Up" checklist. If less than 15 minutes has elapsed since Step 3, use minimum or no prime. _____
5. With alternator switch ON, verify ammeter shows positive charging indication and ALT light off. _____
6. Check clutch engagement time – maximum 80 seconds. _____
7. Both magnetos ground (off momentarily) at 60% RPM. _____
8. Verify ALT light illuminates within 10 seconds after alternator is switched OFF. Verify tachometer operates with alternator and battery switches off. Turn battery & alternator switches on. _____
9. No unusual bearing noise when varying RPM through operating range (mechanic to listen near V-belt drive). Refer to §§ 2.110 and 2.501 thru 2.503. _____
10. Set RPM at 75%, governor on. Increase to 85%, release throttle, and verify governor increases RPM to 101 to 102%. Increase RPM to 104%, release throttle, and verify governor decreases RPM to 101 to 102%. _____
11. Engine and rotor tach needles within 1% of each other at 102% RPM. _____
12. Verify alternator voltage as follows: _____
 - 13.4 to 13.9 vdc for 14-volt A942-3 alternator control unit
 - 27.75 to 29.25 vdc for 28-volt A942-4 alternator control unit
13. Heater operates properly. _____
14. Tachometer needles do not jump more than 2% when transmitting on 118.00, 125.00, and 136.975 MHz with governor on. _____
15. Raise collective control 0.5 inch at grip and slowly decrease RPM. Verify low-rotor-RPM warning horn and light activate at 97% to 96% RPM and remain on as RPM is decreased to idle. _____

2.210 Run Up (continued)

- 16. Idle RPM with engine warm, clutch engaged, throttle closed –
 - O-540 engine: 53% – 57% _____
 - IO-540 engine: 58% – 62% _____
- 17. Idle mixture with engine warm, clutch engaged, throttle closed. _____
 - O-540 engine: 2% to 4% RPM rise as mixture is pulled slowly to idle cut-off. Adjust idle mixture screw as required. If unable to obtain rise, set idle mixture screw 1 ½ turns out from fully in then adjust as required for smooth idle. _____
 - IO-540 engine: Adjust idle mixture per § 6.495, Step 23. _____
- 18. Check hydraulic system operation. Move cyclic-mounted hydraulics switch to OFF. Using small longitudinal cyclic inputs, there should be approximately one-half inch of freeplay before encountering stiffness and feedback. Turn hydraulics ON. Controls should be free with no feedback or uncommanded motion (“motoring”). Complete flight check with hydraulics on. _____
- 19. Air Conditioning: Verify system blows cold air on both low and high settings. Verify no EMI/RFI with other instruments and systems. After a flight with air conditioning on, verify water drains from drain tube in ship’s belly (may be little or no water in very dry conditions). _____

2.220 Flight Check

1. Hover:

- a. All gages green. _____
- b. Controllability in left and right pedal turns. _____
- c. Hydraulics zero cyclic stick forces. _____ |
- d. Vibration levels satisfactory. _____

2. Level Flight: Typical cruise altitude (if possible, deviate as required for weather and regulations), maximum continuous power, governor on.

- a. Vibration levels satisfactory. _____
- b. Hydraulics zero cyclic stick forces. _____ |
- c. Verify no feedback and collective is balanced. _____ |
- d. Tail rotor pedal position when yaw string is centered: 0.25 to 0.75 inch right for adjustable pedals, within 0.25 inch of neutral for non-adjustable pedals. _____
- e. Tail rotor elastic trim cord zeros pedal forces (cord applies left pedal force). _____
- f. Turn hydraulics OFF and verify no excessive feedback forces. _____ |

2.230 Shutdown

- 1. Verify rotor brake functions and ROTOR BRAKE light illuminates. _____
- 2. Complete shutdown per POH checklist. _____

Intentionally Blank

2.300 Airframe Preparation for 100-Hour/Annual Inspection

The airframe must be thoroughly cleaned prior to inspection in accordance with U.S. 14 CFR Part 43, Appendix D, Paragraph (a). Cleaning should include a wipe down main and tail rotor blades, hubs, and airframe exterior with a mild soap (pH between 7 & 9) and water solution per Chapter 23.

CAUTION

Do not spray magnetos, main rotor hub, tail rotor gearbox vent, hydraulic reservoir vent, swashplate area, or bearing seals with high-pressure water or solvent as water or solvent may enter and cause corrosion and breakdown of lubricants.

2.400 100-Hour/Annual Airframe Inspection

CAUTION

If pop-out floats are installed, ensure safety on pilot’s red inflation lever is in LOCKED position when working on helicopter.

WARNING

Pop-out float pressure cylinder contents are under extreme pressure. If pop-out floats are installed, install locking pin in pressure cylinder valve (see Figure 5-6) when working in forward left baggage compartment, during cylinder removal or installation, and when working on floats or inflation hoses. Remove locking pin when work is completed. Avoid excessive heat (> 200 degrees F) as thermal relief valve will activate.

Perform 100 hour or annual airframe inspections per § 2.410. RHC recommends keeping a copy of the most recently performed checklist with the aircraft’s maintenance records.

2.410 Inspection Procedures and Checklist

R44 Serial No.:		Technician name:	
Registration No.:		Technician	
Hourmeter Indication:		Certificate number:	
Aircraft Total Time:			

Numbers in parentheses indicate access location per Figures 2-4 and 2-4A.

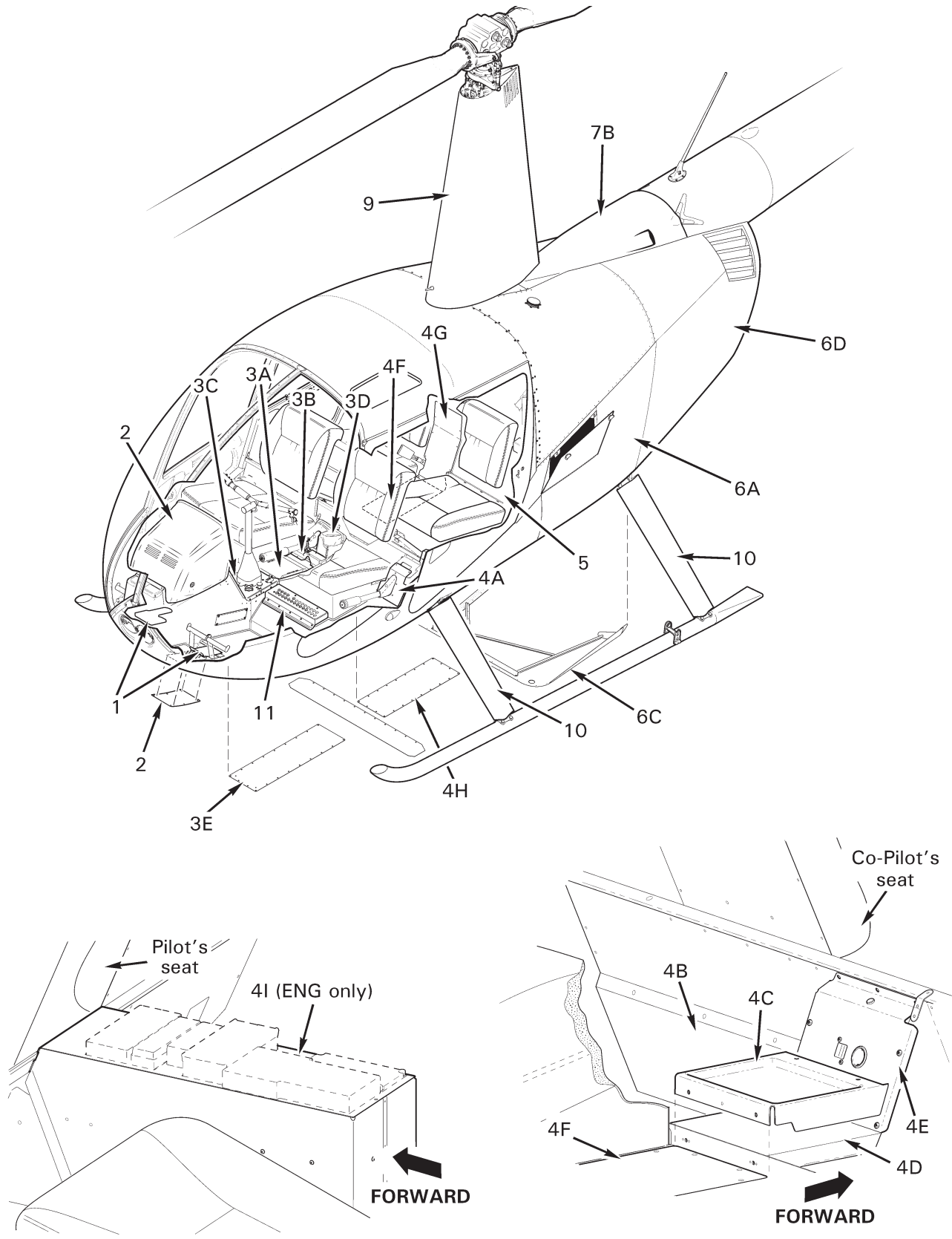

FIGURE 2-4 ACCESS AND INSPECTION PANELS

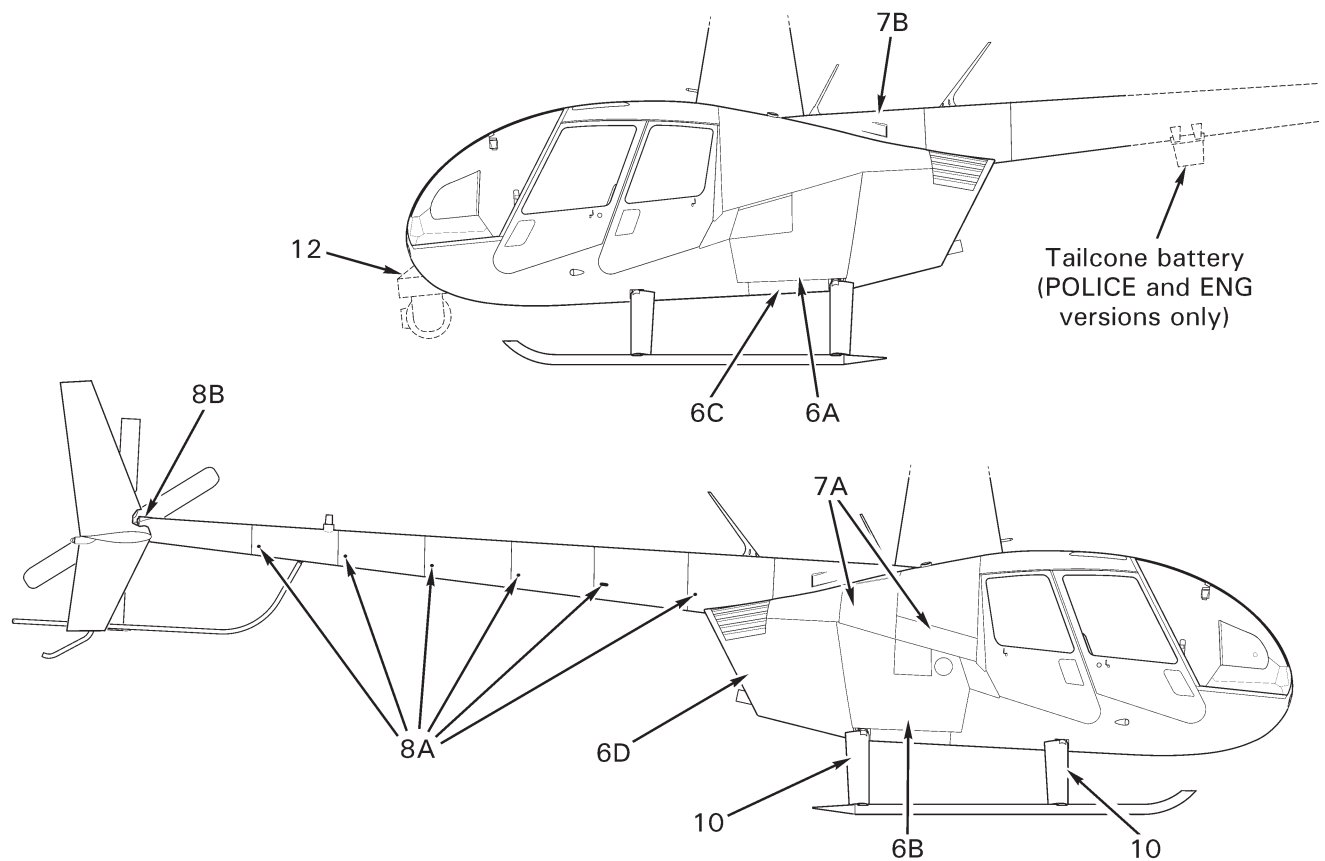

FIGURE 2-4A ACCESS AND INSPECTION PANELS

2.410 Inspection Procedures and Checklist (continued)

1. Tail Rotor Pedal Bearing Blocks

NOTE

Do not remove pedal bearing block cover plates (1) unless function check of pedals indicates possible problem with pedal bearing blocks.

To remove cover plates (1) peel back carpeting and remove screws holding plates. Use an inspection light and mirror to inspect bearing blocks. Inspect for condition and looseness or play. Maximum allowable play is 0.080 inch axially and 0.030 inch radially. Inspect all weld areas in pedal controls.

2.410 Inspection Procedures and Checklist (continued)

2. Remove chin inspection cover, & remove or open upper console assembly per § 13-80:

<p>CAUTION</p> <p>Instrument console removal (§ 13-80) is not required for scheduled inspections. Sufficient access for inspection is gained by removing the chin inspection cover, as well as removal of installed avionics, as required (refer to Chapter 38).</p>

Upper Console Assembly: Inspect condition. Verify hinge security.

Pitot-Static System: Check pitot and static lines for cracking, chafing, pinching or kinking. Check all connections for security. _____

Flight and Engine Gages: Check all gauges for security. Inspect wiring and connections on all gages. _____

Radio Tray(s): Check condition and security. _____

Tail Rotor Controls: Check accessible portions of TR pedal assemblies for defects. Verify operating clearance. _____

3. Remove Forward Tunnel Covers (3A & 3B), Cyclic Stop Cover (3C), Inboard Collective Cover (3D), and Forward Belly Panel (3E) _____

<p>NOTE</p> <p>If radio antennas are installed on removed panels, disconnect antenna lead and any ground wire. Pull respective radio circuit breaker and tag circuit breaker with "Antenna Removed".</p>

Cyclic Box Assembly: Inspect cyclic box assembly for defects. Check cyclic stop sheet metal assembly for cracks and other defects (deterioration, distortion, loose rivets, corrosion). _____

Cyclic Stick Assembly: Inspect cyclic stick assembly for defects. Inspect welds for cracks. _____

2.410 Inspection Procedures and Checklist (continued)

3. Remove Forward Tunnel Covers (3A & 3B), Cyclic Stop Cover (3C), Inboard Collective Cover (3D) and Forward Belly Panel (3E) (continued)

Cyclic Friction: Check for excessive play or looseness in links and rod ends connected to cyclic stick. Verify no excessive flaring at either end of C130-2 spacer. _____

Cyclic Push-Pull Tube and Torque Tube: Inspect C319 torque tube paying special attention to area around blocks and end of torque tube for cracks. Inspect C121-1 push-pull tube rod end palnut and jam nut for tightness. Check witness holes on push-pull tubes. Check rod ends and bearings for excessive play and looseness. Check accessible portions of cyclic push-pull tube and torque tube for defects, including scratches. Pay particular attention to top of torque tube immediately below C348-1 anchor assembly. Inspect all nuts and bolts in cyclic controls for rotation and looseness. Verify operating clearance. _____

Tail Rotor Push-Pull Tube: Inspect accessible portions of C121-9 tail rotor push-pull tube. Check rod ends for excessive play and looseness. Verify operating clearance. _____

Collective Friction and Stop: Inspect collective stop condition; no nicks, cuts or scratches are allowed. Check collective friction lever for security and operation. Move collective up and down and verify no bending or binding of stop. Verify collective boot’s lace cannot entangle stop. _____

Throttle Overtravel Spring: Inspect operation of overtravel spring while operating throttle. It should move freely without any binding or jerkiness. Check play in upper and lower rod ends. Check rod ends for binding. _____

HeliSAS Autopilot (if installed): Inspect condition of associated equipment. Inspect wiring condition. Verify neatness, operating clearance, and security. _____

Wiring Harness: Inspect condition. _____

Pitot and Static Lines: Inspect pitot and static lines for security and any evidence of cracking, chafing, pinching or kinking from sharp bends. Open drains and check for moisture; close drains. _____

Elastic Trim Cords – Cyclic: With cyclic forward-right, feel forward elastic trim cords for voids which may indicate broken strands. _____

Heater Hose: Check heater hose for collapsed areas and chafing. _____

Fasteners and Torque Stripes: Inspect condition and verify security of all fasteners. Renew deteriorated torque stripes per Figure 2-1. _____

2.410 Inspection Procedures and Checklist (continued)

4. Remove Outboard Collective Cover (4A), Collective Torque Tube Cover (4B), Tray (4C), Mid Tunnel Covers (4D & 4E), Aft Tunnel Covers (4F & 4G), Aft Belly Cover Panel (4H), and Rear Console (4I, ENG ships only) (continued)

NOTE

If radio antenna is installed on removed panel, disconnect antenna lead and corresponding ground wire. Pull respective radio circuit breaker and tag circuit breaker with "antenna removed".

Collective Stick: Inspect condition of collective stick. Inspect all welds for cracks. Inspect C328-1 connecting rod assembly giving special attention to points of attachment. Inspect governor motor and governor motor arm for looseness or binding. Inspect collective-activated micro switch for cracks or loose wires. Verify operating clearance of collective and throttle governor, to include no evidence of rubbing on inside of removed cover. _____

Collective Stick Torque Tube: Verify no corrosion pitting. Apply a corrosion-preventative compound such as LPS 2, ACF-50, or Corrosion-X to any unpainted, phosphate-coated area while avoiding contaminating governor friction clutch (a foam-type applicator works well). Ensure interior of open-end "box" structures at inboard attach point and at A205 fork connection are also treated. _____

Aft End of Cyclic Torque Tube and Yoke Assembly: Inspect torque tube and yoke, paying special attention to area around blocks and end of torque tube for cracks. Check play in bellcrank bearings per § 2.122. Inspect swaged bearing for movement in yoke. _____

Aft End of Cyclic Horizontal Push-Pull Tube (C121-1) and Lower Ends of Vertical Push-Pull Tubes: Inspect push-pull tubes for cracks. Check rod end jam nuts and palnuts for tightness and rod ends for play. Check rod end bearings for looseness. Inspect fork assembly areas. Check bearings for looseness. Check between bearings and swage for evidence of fretting. _____

Aft End of (C121-9) Tail Rotor Push-Pull Tube and Lower Bearing: Check witness hole. Check lower bellcrank bearing for play. Inspect all welds on support assembly for lower bellcrank and inspect surrounding sheet metal area for cracks. _____

Elastic Trim Cord – Tail Rotor: Feel elastic trim cord for voids which may indicate broken strands. _____

Collective Push-Pull Tube (C121-19): Check for binding or nicks. Check witness holes. Check jam nuts and palnut for tightness and rod end for play. _____

2.410 Inspection Procedures and Checklist (continued)**4. Remove Outboard Collective Cover (4A), Collective Torque Tube Cover (4B), Tray (4C), Mid Tunnel Covers (4D & 4E), Aft Tunnel Covers (4F & 4G), Aft Belly Cover Panel (4H), and Rear Console (4I, ENG ships only) (continued)**

Elastic Trim Cord – Collective: Feel elastic trim cord for voids which may indicate broken strands. _____

Collective Friction Assembly: Check jam nuts and palnuts for tightness and rod ends for play. Inspect all welds on bellcrank support assembly and inspect surrounding sheet metal for cracks and corrosion. _____

Throttle Control Linkage: Remove throttle control arm cover if cover is not transparent (under aft left seat [O-540], or inside tunnel [IO-540], at firewall). Inspect condition. Verify throttle control clearance to installed equipment and adjacent structure. Verify proper installation and security. Install cover. _____

Fuel Valve and Fuel Line: Inspect fuel line for damage and valve fittings for leakage (leakage is indicated by a blue or green residue, depending on fuel used, or odor of fuel). Verify no chafing of fuel lines. _____

Fuel Valve-to-Knob Torque Tube: Inspect condition. Verify attaching security. _____

Intentionally Blank

2.410 Inspection Procedures and Checklist (continued)

5. Remove Aft Seat Back Assemblies (5)

Wiring: Verify security, proper installation, and no deterioration. _____ |

Pitot and Static Lines: Check for security, chafing, and kinks. _____

Air Conditioning Refrigerant Lines (if installed): Verify security & no damage. _____

Evaporator Drain Tubes and Valve (if installed): Verify tubes are unobstructed. Place a container under sediment-tube protruding from bottom of tee-fitting into right-aft baggage compartment. Remove plug from sediment tube and allow any accumulated moisture and debris to drain. Reinstall plug. Simultaneously squeeze drain tube and sediment tube near tee-fitting and verify check-valve ball moves up momentarily. _____

Strobe Power Supply & Alternator Control Unit: Verify security. Inspect wiring. Inspect mounting panels for cracks. _____ |

Blind Encoder & Governor Controller: Verify security. Inspect wiring. Inspect mounting panels for cracks. _____ |

Fasteners and Torque Stripes: Inspect condition and verify security of all fasteners. Renew deteriorated torque stripes per Figure 2-1. _____

6. Remove Engine Aft (6D), Belly (6C), and both side (6A & 6B) Cowlings

Vertical Firewall: Inspect vertical firewall condition, especially around structural attachment points, verify no cracks, buckling or wrinkles. _____

Fuse(s) and Fuse Holder(s) (if installed on vertical firewall): Verify security and no corrosion. Verify correct fuses: -66 wire requires AGC-3 fuse, -1601/-1602 wires require AGC-5 fuse. If installed, -1226 wire requires AGC-3 fuse. _____

Wiring: Verify security, proper installation, and no deterioration. _____

Electric Fuel Pump (IO-540 only): Verify security, proper installation, unobstructed drain tube, and no leakage. _____

Fuel Line & Hose(s): Inspect condition. Verify security, proper installation, no leakage, & (IO-540 only) good condition of spirap insulation on fuel line between firewall & gascolator. If deteriorated, replace MS3367-5-9 ty-raps securing fuel hoses to clamps (reference R44 SB-67). _____

Lower Steel Tube Frames: Thoroughly inspect lower steel tube structure for corrosion and inspect all welds for cracks. Ensure frames are not chafed by wires, hoses, clamps, etc. _____

Engine Cooling Panels: Inspect cooling panels for cracks and missing fasteners. _____

Oil Cooler(s): Inspect oil cooler(s) and fittings for damage, leaks, cleanliness, and security. Check oil cooler mounting area(s) for cracks. _____

2.410 Inspection Procedures and Checklist (continued)

6. Remove Engine Aft (6D), Belly (6C), and both side (6A & 6B) Cowlings (continued)

Oil Lines: Inspect entire length of all oil lines and verify no cracks, abrasion, or broken clamps. Verify clearance; wires, ty-raps, and structure must not contact lines. _____

Gascolator: With fuel valve off, remove and clean gascolator bowl and filter screen. Verify no deterioration of gasket. If gascolator bowl is secured by threaded collar and ring, lightly lube threads and ring with A257-6 grease. Reassemble and turn fuel valve on. Safety wire after ensuring no leaks occur. Verify drain valve is secure and torque-stripped. _____

Mixture Control: Verify mixture control moves mixture control arm stop to stop. Inspect condition and verify security of mixture control cable clamps on bracket; push and pull cable housing to ensure it does not slip in clamps. Inspect condition and verify security of mixture control cable inner wire attachment to mixture control arm. Ensure freedom of rotation between mixture control arm and inner wire retention fitting (bolt) when arm moves. Verify mixture control safety spring is properly installed (so spring force holds mixture control arm at full-rich position if inner wire breaks). _____

Throttle Correlation Rigging: Check per § 10.150 and adjust as required. _____

Full-Throttle Switch Rigging: Check per § 37-70 and adjust as required. _____

Throttle Control Linkage: Inspect condition. Verify throttle control operating clearance to installed equipment and adjacent structure. Verify proper installation and security. _____

Air Box & Alternate Air Door: Ensure carburetor heat slider valve (if applicable) moves fully from stop to stop. Replace air filter (lubricating IO-540 air filter rubber with A257-8 rubber lubricant will facilitate sealing). Check air box for condition and security. Verify spring-loaded alternate air door opens without binding and closes completely. _____

Engine Air Inlet Hose: Verify no rips, holes, or collapsed areas. Remove hose from fuel-injected R44 II. Visually inspect inside of hose to verify no separation between outer and inner layers. Also, flex the hose in all directions and listen for a crinkling sound, which is an indication of separation. (An airworthy hose does not make a crinkling sound when flexed.) Replace any hose with any indication of separation. Install hose on fuel-injected R44 II. Verify correct installation & security. Ensure hose is not chafing frame. _____

Carburetor Heat Scoop and Hose (O-540 engines only): Inspect for condition and security. _____

Heater Hose: Inspect for condition and security. _____

2.410 Inspection Procedures and Checklist (continued)

6. Remove Engine Aft (6D), Belly (6C), and both side (6A & 6B) Cowlings (continued)

Lead-Acid Battery Installations (under left front seat, left-side engine compartment, or mounted to tailcone): Refer to § 37-11. Inspect condition. Verify no cracks or corrosion on or near battery terminals. As required, perform capacity test per manufacturer’s instructions or replace battery. Verify battery cable security. Verify no corrosion in surrounding structure. _____

Lithium-Ion Battery Installation (if equipped; under left front seat or left-side engine compartment): Refer to § 37-12. Inspect condition. Verify no cracks or corrosion on or near battery terminals. Verify vent hose, comm connector wiring, and battery cable security. Perform scheduled maintenance as required. Verify no corrosion in surrounding structure. _____

7. Open Cowling Doors (7A), Remove Tailcone Cowling (7B) & Mast Fairing (9)

Cowling Door: Inspect hinges and latches for condition and security. _____

Tailcone cowling: Verify no cracks, air inlet obstructions, or loose rivets. _____

Electrical and Antenna Wires: Inspect condition. Verify security and no chafing, kinks or tight bends. _____

Emergency Locator Transmitter (ELT; if installed): In accordance with local regulation, test per ELT manufacturer instructions. If 406 Mhz ELT, confirm programming tag matches helicopter registration. If RHC installation, inspect condition of both primary hook & loop strap and secondary buckle strap or ty-rap; replace strap(s) if damaged or deteriorated. Verify ELT security and clearance to drive train. _____

MRGB Input Yoke: Inspect condition. Verify security and operating clearance. Verify security of magnets. _____

Intentionally Blank

2.410 Inspection Procedures and Checklist (cont'd)

7. Open Cowling Doors (7A), Remove Tailcone Cowling (7B) & Mast Fairing (9)
(cont'd)

Forward Flex Plate: Inspect condition, particularly edges. Verify security. Verify bonded washers are securely bonded to both sides of each flex plate arm. Verify operating clearance.

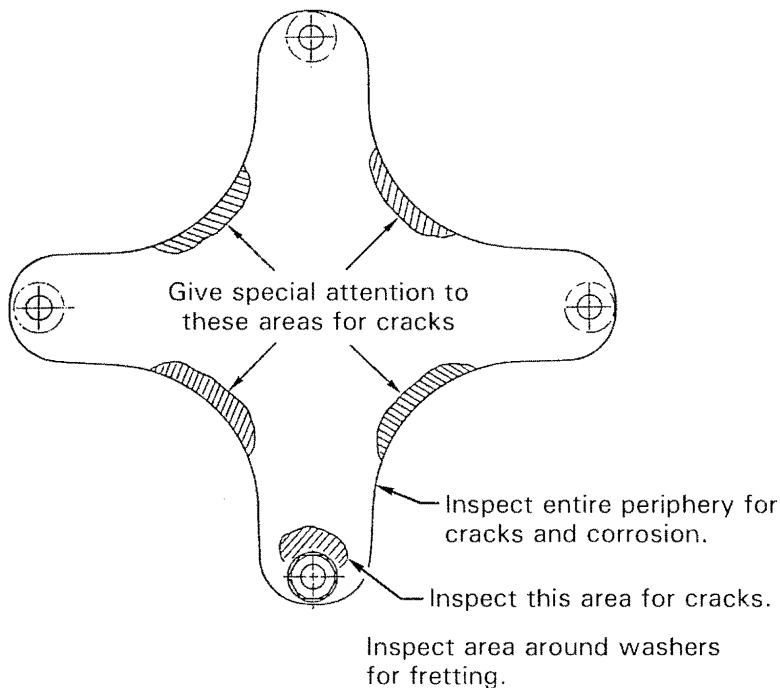

FIGURE 2-5 FLEX PLATE INSPECTION

Clutch Shaft Forward Yoke: Inspect condition. Verify no cracks, corrosion, or fretting. Verify security and operating clearance.

Rotor Brake: Inspect condition, including activating cable & pulleys and microswitch. Verify integrity of brake pads and 0.030 inch minimum pad thickness. Verify brake pad clearance to input yoke when brake is off. Verify security and operating clearance.

Jackshaft: Inspect entire welded assembly for cracks and corrosion. Inspect jackshaft supporting strut and tube weldments for security, cracks and corrosion.

Main Rotor Push-Pull Tubes: Inspect condition of viewable portions. Verify no cracks at ends. Inspect rod ends per Section 2.120. Verify no tears in sleeves (manual controls only). Verify security and operating clearances.

Main Rotor Push-Pull Tube Rollers & Bushings: (manual controls only): Inspect condition. Verify cleanliness, no wear into metal, and free movement of rollers.

2.410 Inspection Procedures and Checklist (cont'd)

7. Open Cowling Doors (7A), Remove Tailcone Cowling (7B) & Mast Fairing (9)
(cont'd)

Tail Rotor Push-Pull Tube and Upper Bellcrank: Inspect C121-15 push-pull tube, especially at ends, for cracks. Check jam nut for tightness and rod end for looseness. Inspect bellcrank and mounting for cracks or other defects.

Main Rotor Gearbox Cooling Hoses: Inspect both ends for security. Inspect for rips, holes, and chafing.

Main Rotor Gearbox: Inspect main rotor gearbox, especially around gearbox mounts, cap mounting lugs, and mast tube for cracks. Verify no contamination and no deterioration of rubber mounts. Verify security of Hall Effect senders. Check Telatemp for overtemp indications.

Main Rotor Gearbox Oil: With ship on level ground, verify correct oil level and cleanliness using sight gage. If required by Section 1.101, drain and flush gearbox per Section 1.120.

Main Rotor Gearbox Chip Detector: If required by Section 1.101, clean chip detector per Section 1.115.

Upper Steel Tube Frame: Use an inspection light and mirror to inspect each weld, verify no cracks or corrosion.

CAUTION

Upper steel tube frame is fatigue-loaded and therefore susceptible to fatigue cracks. Inspect thoroughly.

Horizontal Firewall: Inspect upper and lower surfaces of horizontal firewall, especially where bolted to steel structure, for cracks, buckling, or wrinkles. Inspect firewall under fuel tank for leakage (fuel residue).

Fuel Tanks: Inspect condition of visible portion. Verify no leaks. Verify security.

Auxiliary Fuel Tank Fuel Line: Inspect condition. Verify clearance to structure. Verify no leakage. Verify security.

Fuel Return Lines & Pressure Relief Valve (IO-540 only): Inspect condition. Verify no leakage. Verify security.

Fuel Gage Senders & Wiring: Inspect condition. Verify no leaks.

Fuel Tank Vents: Check vent tube connections for security.

Fuel Tank Sump Drains: Verify both drain valves open easily, drain fuel freely, spring closed, and seal completely. Verify D663-1 shut-off clamp on aux tank drain tube seals completely, and inspect clamp and tube for damage and deterioration.

Low Fuel Warning: Turn MASTER switch on. With a clean wooden dowel, gently depress low-fuel sender float in main fuel tank and verify LOW FUEL warning light illuminates. Turn MASTER switch off.

2.410 Inspection Procedures and Checklist (continued)

7. Open Cowling Doors (7A), Remove Tailcone Cowling (7B) & Mast Fairing (9) (cont'd)

Fuel Caps: Inspect condition, to include gasket. Verify security when closed. Verify alignment marks on cap and tank align when cap is fully closed. Verify cap has aluminum bar shown in Figure 12-3A. _____ |

Nuts and Bolts: Inspect all nuts and bolts in this area for movement and looseness. _____

Cabin Bulkhead & Forward Hydraulic Servo Mounts: Inspect bulkhead and servo mounts (if installed) for corrosion, loose rivets, deformation and cracks. _____

Clutch Assembly: Inspect ends of drive shaft and seals on sheave for oil leakage. Inspect shaft for corrosion, especially at shaft-to-seal junctures. Remove any light surface corrosion at shaft-to-seal junctures, and apply B270-21 corrosion-inhibitor. _____ |

Upper Sheave: Inspect sheave grooves. Replace any sheave showing corrosion pitting or flaking of metalized or anodized coatings, wear through anodized coatings, roughness, or sharp ridges. _____

Drive V-Belts (see Section 2.507): Inspect V-belts. Verify no breakage, deterioration of rubber, cuts, fraying, oil, grease, or foreign objects. _____

Actuator Fuses & Holders: Inspect condition. Verify no corrosion. Verify correct fuses (14-volt systems require AGC-3 fuses while 28-volt systems require AGC-1 ½ fuses). Verify twist-to-lock function and security. _____

Actuator Upper Bearing and Strut: Inspect seals on both sides of bearing for damage. Inspect strut, including both rod ends, and check witness holes. Check for fretting between bearing inner races and clutch shaft. Bearing inner races should be torque striped to clutch shaft. If stripes are broken or misaligned, shaft is unairworthy. Check bearing Telatemp. Perform bearing inspection per § 2.503 if Telatemp indication has increased without corresponding increase in ambient temperature. _____

Actuator Lower Bearing: Inspect as much of bearing as can be seen. Inspect fiberglass scroll area at bearing attachment brackets for signs of cracking. Check bearing seals for evidence of deterioration. Inspect lower bearing brackets for looseness or wear. Inspect bearing per § 2.502 if discrepancies are found. _____

Intermediate Flex Plate and Forward End of Tail Rotor Drive Shaft (see Figure 2-5): Inspect flex plate for cracks and fretting. Inspect yoke-to-drive shaft weld for cracks (steel shafts). _____

Tailcone Attachment: Thoroughly inspect all welds in this area for cracks, corrosion, and security of attaching fasteners. Inspect tailcone mounting area for cracks. _____

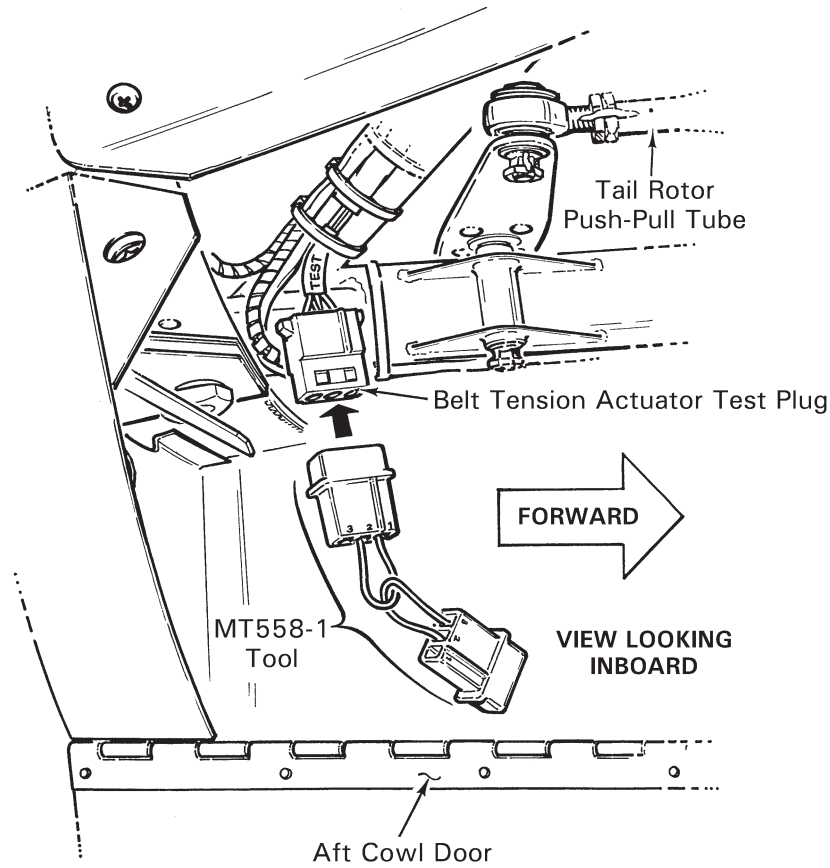

FIGURE 2-6 MT558-1 TOOL INSTALLATION

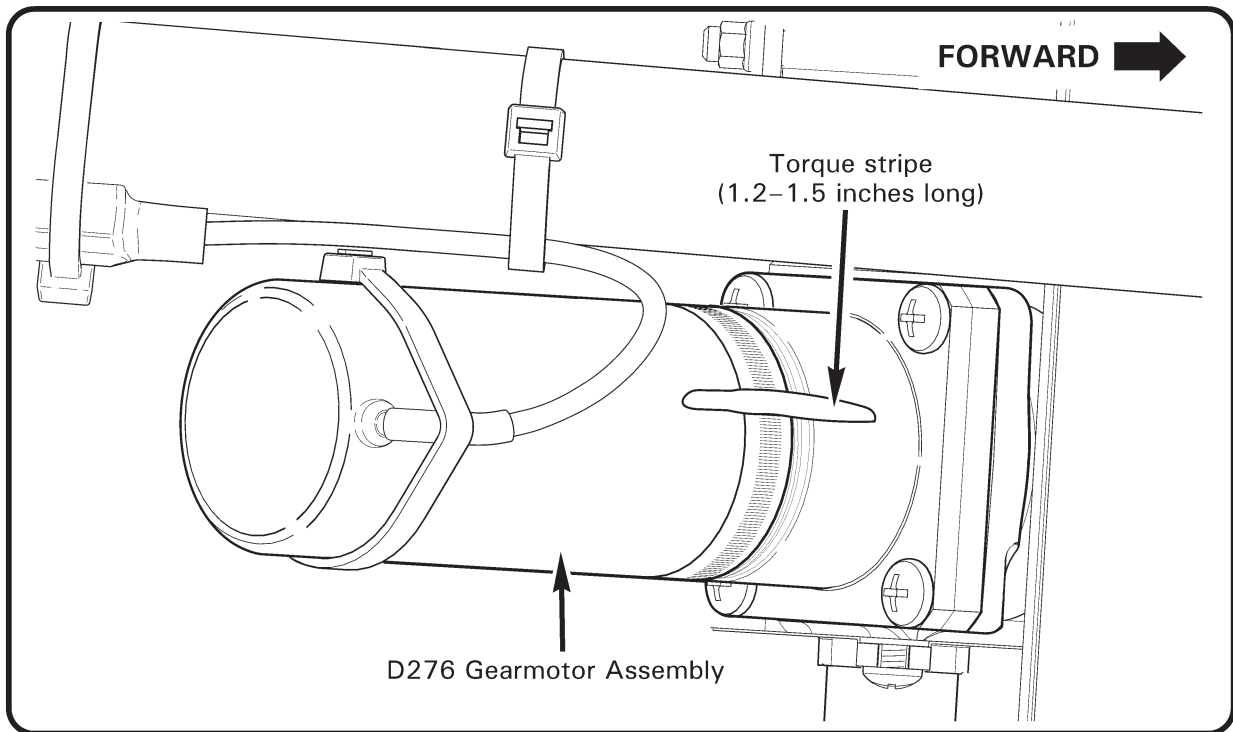

FIGURE 2-6A GEARMOTOR ASSEMBLY TORQUE STRIPE

2.410 Inspection Procedures and Checklist (continued)

7. Open Cowling Doors (7A), Remove Tailcone Cowling (7B) & Mast Fairing (9) (cont'd)

Actuator (CO51): Verify clearance to structure and drive train when fully disengaged. Turn master switch on and engage clutch switch. While actuator is engaging, depress extension limit switch lever (refer to Figure 7-15) and verify gearmotor stops; release lever and verify gearmotor resumes running. Verify integrity of activating cable for extension limit switch. Use an inspection mirror to observe column springs at end of belt-tensioning cycle; springs should snap outward simultaneously. Verify maximum engaged extension limit per Figure 7-15 is not exceeded. Verify clearance to structure and drive train when fully engaged. Verify down-limit stop screw jam nut is tight.

Check actuator for failed-closed spring switch as follows (actuator electrical harness must be equipped with "Test" plug per Figure 2-6):

- a. With BATTERY switch on and actuator fully engaged, connect one end of MT558-1 tool to actuator test plug and verify gearmotor remains off.

CAUTION

If gearmotor activates when installing MT558-1 tool then a spring switch has failed in closed position; immediately remove MT558-1 to prevent actuator damage.

- b. Disconnect MT558-1 tool, connect opposite end to actuator test plug, and verify gearmotor remains off.
- c. Disengage clutch and turn BATTERY switch off.
- d. MT558-1 pins 1 & 2 jumper tests wire 98 spring switch; pins 2 & 3 jumper tests wire 91 spring switch (see Figure 14-1D). Replace any malfunctioning switch per § 7.551 before further flight.

Gearmotor Assembly Torque Stripe: Refer to Figure 2-6A. Verify torque stripe is not broken or missing. Renew deteriorated torque stripe as required.

2.410 Inspection Procedures and Checklist (continued)

7. Open Cowling Doors (7A), Remove Tailcone Cowling (7B) & Mast Fairing (9) (cont'd)

Lower Drive Sheave: Inspect lower sheave. Replace any sheave showing corrosion pitting or flaking of metalized coating, wear grooves, roughness, or sharp ridges.

Sheave Alignment: Verify sheave alignment per § 7.230. Adjust as required.

Hydraulic Reservoir: Inspect condition. Verify security and no significant leakage. If required by § 1.101, replace filter per § 1.170. Drain and flush hydraulic system per § 1.180 if oil has turned dark or emits bad odor. Add fluid as required.

CAUTION
Cleanliness of hydraulic fluid is vital to proper system operation. Use only clean fluid from sealed containers and avoid contamination from dirty funnels, tubing, etc.

Hydraulic Reservoir Cooling Hose: Inspect condition. Verify hose is secure and is directed at center of reservoir cooling fins.

Hydraulic Pump: Inspect condition. Pump temperature indication should not exceed gearbox temperature indication. Verify security and no significant leakage.

Forward Hydraulic Servos: Inspect condition. Inspect rod ends per § 2.120. Verify security and no significant leakage. Verify servo input rod end/clevis area is clean; cleanse area with non-residue, non-alcoholic solvent as required. Verify approximately 0.040 inch total free-play at servo valve input. Verify valve clearance to surrounding structure while flight controls are moved through full range of travel. Inspect condition and verify security of scissors at upper clevis of servos.

CAUTION
Use LPS PreSolve to clean hydraulic parts. Do not use alcohol.

Aft Hydraulic Servo: Inspect condition. Inspect rod ends per § 2.120. Verify security and no significant leakage. Verify servo input rod end/clevis area is clean; cleanse area with non-residue, non-alcoholic solvent as required. Verify approximately 0.040 inch total free-play at servo valve input. Verify valve clearance to surrounding structure while flight controls are moved through full range of travel.

2.410 Inspection Procedures and Checklist (continued)**7. Open Cowling Doors (7A), Remove Tailcone Cowling (7B) & Mast Fairing (9) (cont'd)**

Aft Hydraulic Servo: Inspect rod ends per § 2.120. Inspect attachment to sheet metal, verify no cracks. Verify security. _____

Hydraulic Lines & Fittings: Inspect condition. Verify valve clearance to surrounding structure while flight controls are moved through full range of travel. Verify security and no leakage. Verify minimum 0.25 inch clearance between pump hoses and aux fuel tank. _____

Fasteners and Torque Stripes: Inspect condition and verify security of all fasteners. Renew deteriorated torque stripes per Figure 2-1. _____

2.410 Inspection Procedures and Checklist (continued)

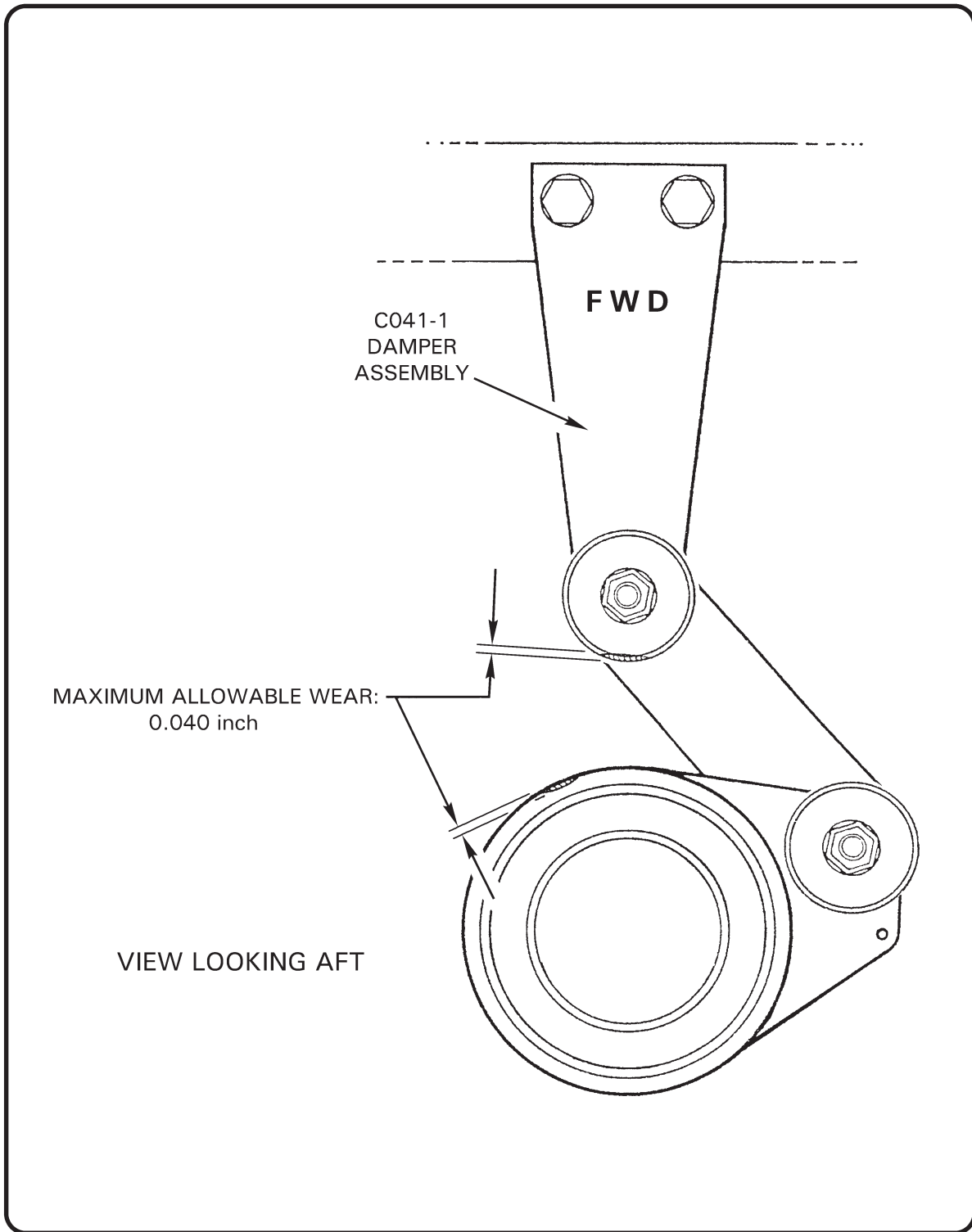

FIGURE 2-8 TAIL ROTOR DRIVE SHAFT DAMPER BEARING INSPECTION

2.410 Inspection Procedures and Checklist (continued)

8. Remove Tailcone Plugs (8A) & Aft Plastic Cover (8B)

NOTE

Aft plastic cover (8B) is secured with two MS27039C0806 screws on Rev L and subsequent tailcones. On Rev K and prior tailcones ensure screws securing plastic cover are short enough to prevent interference in aft flex plate area.

Tail Rotor Drive Shaft Assembly: Examine accessible portion through inspection holes with inspection light and mirror. Verify no cracks, corrosion, or fretting in fore and aft bonded sleeves. Verify no evidence of drive shaft contact with tailcone bays. Verify no bends, bowing, dents, cracks, or corrosion. Perform tail rotor drive shaft runout per § 7.340. Verify proper installation, security, and operating clearance.

CAUTION

Bends, bowing, dents, cracks and corrosion are cause for immediate replacement of tail rotor drive shaft.

Tail Rotor Push-Pull Tube & Forward Bellcrank: Examine accessible portion through inspection holes with inspection light and mirror. Inspect condition per § 2.121. Verify no nicks, scratches, dents, cracks, or corrosion. Inspect rod end bearings per § 2.122; verify rod ends are centered and palnut and jam nut are tight. Check witness holes for proper thread engagement. Inspect bellcrank and bellcrank mount for nicks, scratches, dents, cracks, or corrosion. Inspect spherical bearings per § 2.122. Verify proper installation, security, and operating clearance. Verify tail rotor guard mounting screw shanks clear push-pull tube.

Tail Rotor Drive Shaft Damper Assembly: Verify no obvious damage. Verify integrity of bearing seals. Inspect bearing housing for excessive wear (see Figure 2-8). Verify bearing's inner race-to-drive shaft torque stripe is intact and no evidence of bearing slippage. Verify proper orientation, security, and smooth operation.

Aft Flex Plate (refer to Figure 2-5): Inspect condition. Verify no obvious damage. If fretting is detected, replace flex plate. Verify bonded washers are installed on both sides of each flex plate arm. Verify security and operating clearance.

Tail Rotor Drive Shaft Aft Yoke: Using inspection hole, check yoke for cracks, fretting, and corrosion.

2.410 Inspection Procedures and Checklist (continued)

8. Remove Tailcone Plugs (8A) & Aft Plastic Cover (8B)

Tailcone Interior: Inspect condition. Verify no cracks in damper mount angle. Verify wear at push-pull tube & bulkhead bushing (6 places) is not excessive. Remove debris. _____

Tailcone Exterior: Inspect condition. Verify drain hole in each bay is clear. Verify no cracks at antenna mounts and battery attachment (if on tailcone). _____

Tailcone Battery (if installed): Inspect condition. Verify no debris between battery box cover and tailcone. Verify security. _____

F050-2 Horizontal Stabilizer (if installed): Inspect condition. Verify security. _____

Strobe Light: Inspect lens and strobe light mount for cracks, loose rivets, and security. If split red/clear lens is installed, verify clear half of lens faces aft. _____

Antennas: Inspect condition. Verify no cracks where antennas mount to tailcone. Verify security. _____

Tailcone Attachment: Inspect condition and security of four bolts attaching tailcone to upper frame. _____

Empennage: Inspect condition. Verify no evidence of tail skid strike. Verify drain holes in lower vertical stabilizer and tail skid are clear. Verify proper installation and security. _____

Tail Rotor Guard: Inspect condition. Verify no cracks or corrosion at attach points. Verify security. _____

Float Stabilizer (if installed): Inspect condition and security. _____

2.410 Inspection Procedures and Checklist (continued)

9. Tail Rotor Gearbox and Tail Rotor

Input Shaft Yoke: Inspect flange and weld for cracks and corrosion. _____

Input Seal: Inspect for leakage. _____

Gearbox: Inspect general condition. Look for leakage. Check oil quantity and cleanliness through sight gage and adjust or flush as required. Check gearbox-to-tailcone mounting security. Inspect output shaft for nicks, scratches and corrosion. Check safety wire on applicable gearbox bolts. Check Telatemp. _____

NOTE

At 500 hours time-in-service or annually, whichever occurs first, remove chip detector and clean varnish from detector’s magnetic probe and adjacent metal body (a toothbrush dampened with solvent works well). Also, drain and flush gearboxes at intervals not to exceed 500 hours time-in-service (refer to § 1.101).

Pitch Control Assembly and C121-17 Push-Pull Tube: Check pitch control assembly for free movement throughout its entire range and for looseness on output shaft (0.25 inch maximum rotational play measured at pitch link attach bolt). Inspect bellcrank for cracks and ensure free movement. Pay special attention to spherical bearing atop stud protruding from underside of pitch control; it is permissible to have a single radial crack in the spherical bearing ball. Inspect aft end of C121-17 push-pull tube for cracks and check rod end for excessive looseness (refer to R44 SB-43A). _____

Pitch Links: Check rod ends for excessive looseness. If equipped with one-piece pitch links, disconnect and rotate inboard end outboard as required to obtain maximum service life. Additionally, an optional A215-012 o-ring may be installed on A115-1 spacer under both bolt heads at pitch control. _____

Tail Rotor Blades: Inspect blade surfaces for excessive erosion, nicks, scratches, cracks, corrosion, voids, or debonding. Check tail rotor blade root fitting bearings for fretting and looseness. Loose bearing outer race in root fitting is unairworthy, requiring replacement of blade. C029-1 blades only: remove tip covers, inspect for debris and corrosion, & reinstall covers. Inspect condition and perform tail rotor blade care per § 9.470. C029-1 or C029-2 blades only: Inspect tail rotor blades for fatigue cracks per U.S. AD 2020-08-10. _____

2.410 Inspection Procedures and Checklist (continued)

9. Tail Rotor Gearbox and Tail Rotor

Hub Plates and Hub: Inspect for cracks and corrosion, paying special attention to areas around blade and hub mounting bolts. Ensure teeter hinge bearing outer races move with hub and bearing inner balls and retaining nut and bolt remain stationary when hub is teetered. Hub should move freely on bearings without stiffness or jerkiness. Check teeter hinge bearings for excessive play. For elastomeric bearings inspect per § 2.125. _____

Fasteners and Torque Stripes: Inspect condition and verify security of all fasteners. Renew deteriorated torque stripes per Figure 2-1. _____

10. Open Mast Fairing (9)

Mast Fairing: Inspect condition, especially where stiffeners intersect ribs. _____

Lower Swashplate Scissors: Inspect condition of scissors. Check rod end and bearing play. Check jam nut. _____

Vertical Push-Pull Tubes: Inspect for general condition and corrosion. For manual controls, inspect push-pull tube sleeves at rollers and guide. _____

Rod Ends: Check push-pull tube rod ends per § 2.120. _____

Plastic Rollers and Guide (manual controls): Inspect plastic rollers and guide for cleanliness, security, and deterioration. _____

Pitot Tube: Inspect pitot line and tube, giving special attention to connecting area, for bending, cracking and kinking. Verify pitot tube elbow drain hole is unobstructed. _____

Fuel Tank Vents: Inspect condition and security of fuel tank vent tube clamps. Ensure pitot line is not chafing fuel vent tubes. Check tube connections. Verify tubes are unobstructed and are not kinked, pinched, or chafing. _____

Mast Fairing Ribs: Inspect for cracks especially around mast tube attachments. _____

11. Rotor Hub Area

Swashplate Lower Scissors: Inspect condition. Inspect rod ends per § 2.120. Verify security. _____

Swashplate Upper Scissors: Inspect condition. Inspect rod ends and spherical bearings per § 2.120. Measure scissors play per Figure 2-9. Observe scissor linkage while having someone raise and lower collective. Verify bolt, journals (or spherical bearing balls and spacers), and arm rotate together at each scissor linkage pivot. Verify operating clearance. _____

2.410 Inspection Procedures and Checklist (continued)

11. Rotor Hub Area (continued)

Swashplate Slider Tube: Inspect condition. Verify no cracks at rivet holes or corrosion on base. Verify no damage to, or wear through, anodized tube surface. _____

Remove Swashplate Boot Lower Ty-rap: Lift boot from swashplate. Using an inspection mirror, inspect area between main rotor drive shaft and inside of slider tube. Verify no corrosion and no debris. Verify no boot damage. _____

Swashplate: Inspect condition. Verify 0.020 inch maximum radial play between swashplate ball and slider tube. Rotate rotor by hand and verify operating clearance and no rough or dry bearings. _____

Swashplate Tilting Friction: Observe swashplate ball from below and have someone move collective stick slowly up & down. Verify swashplate ball immediately moves with swashplate when swashplate reverses direction. Movement of swashplate without attendant ball movement indicates axial play between ball and swashplate; adjust swashplate tilting friction per § 8.413. _____

Intentionally Blank

2.410 Inspection Procedures and Checklist (continued)

11. Rotor Hub Area (continued)

Install Swashplate Boot Lower Ty-rap: Verify correct boot position and security and no boot damage. _____

Hub: Inspect condition. Verify no nicks, scratches, gouges, or corrosion. If main rotor imbalance is suspected, check teeter and coning hinge friction per § 28-32. Verify no brown or black residue (indicates bearing wear). _____

Hinge Bolts: Inspect condition. Verify cotter pins are in place and secure. Verify bolt heads and nuts are torque striped to thrust washers. _____

Pitch Links and Rod Ends: Inspect condition. Inspect rod ends per § 2.122, including centering. Verify security, including jamnut tightness and proper safety wiring. _____

Fasteners and Torque Stripes: Inspect condition and verify security of all fasteners. Renew deteriorated torque stripes per Figure 2-1. _____

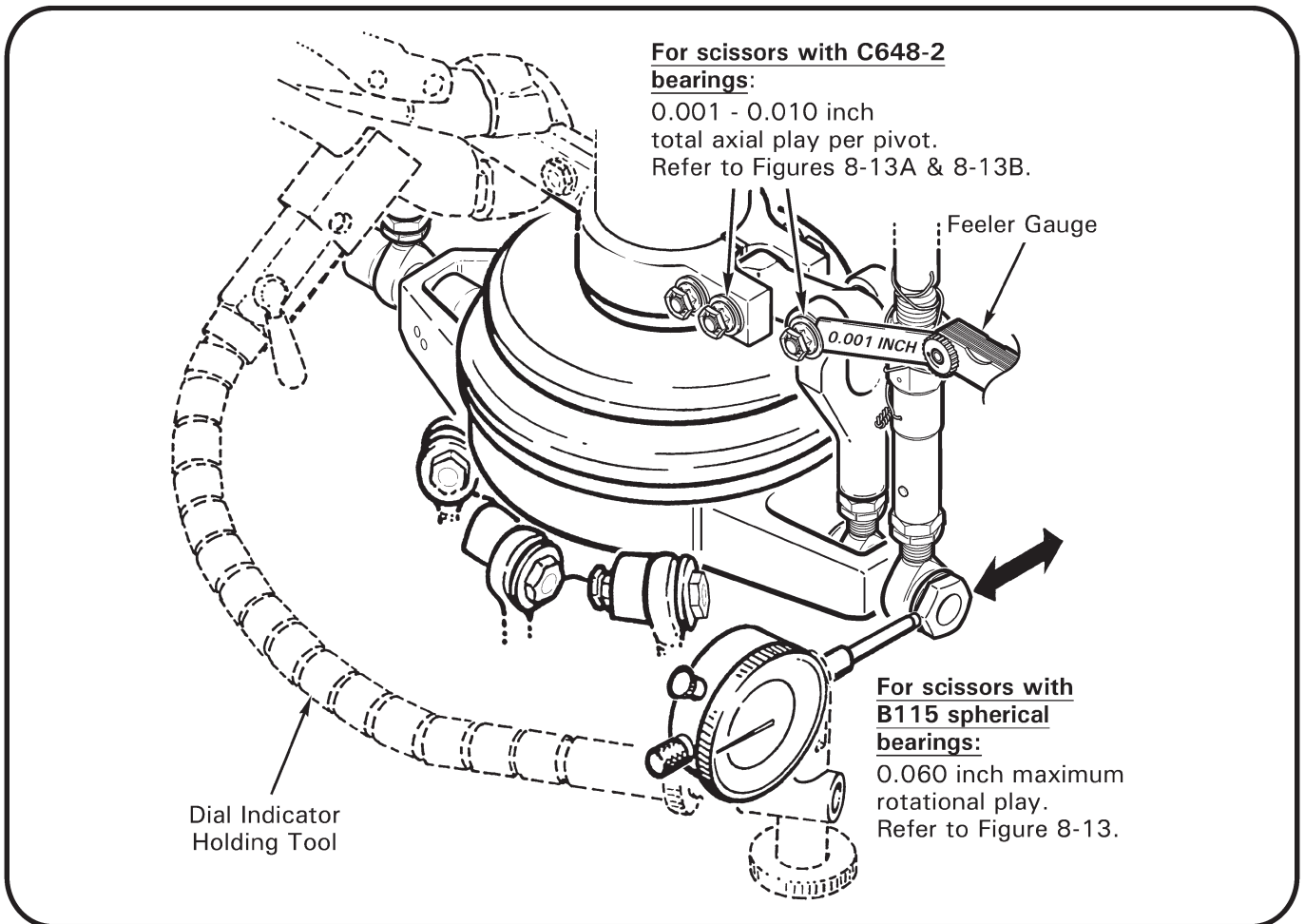

FIGURE 2-9 MEASURING UPPER SWASHPLATE ROTATIONAL PLAY
 (Identify scissors bearing type and measure as shown)

2.410 Inspection Procedures and Checklist (continued)

12. Main Rotor Blades

Boots: Inspect condition. Verify no boot damage or oil leakage. Verify proper boot position and security. Verify sufficient clearance from hub assembly through full control travel.

Blade Spindles & Root Fittings: Inspect area for damage per § 28-43. Verify proper installation and security of visible fasteners. Renew deteriorated torque stripes per Figure 2-1.

Main Rotor Blade Tip Maintenance: Perform main rotor blade tip maintenance per § 28-60.

Main Rotor Blade Inspection: Inspect skins and doublers for scratches and corrosion per § 28-41. Inspect blades for dents and local deformations per § 28-42 and for voids per § 28-44. As required, wax blades with soft cleaning cloths using carnauba-type wax (such as SC Johnson® Paste Wax). Ensure tip cover and blade tip drain holes are unobstructed.

WARNING

Structural damage may occur if compressed air is applied to blade tip drain holes.

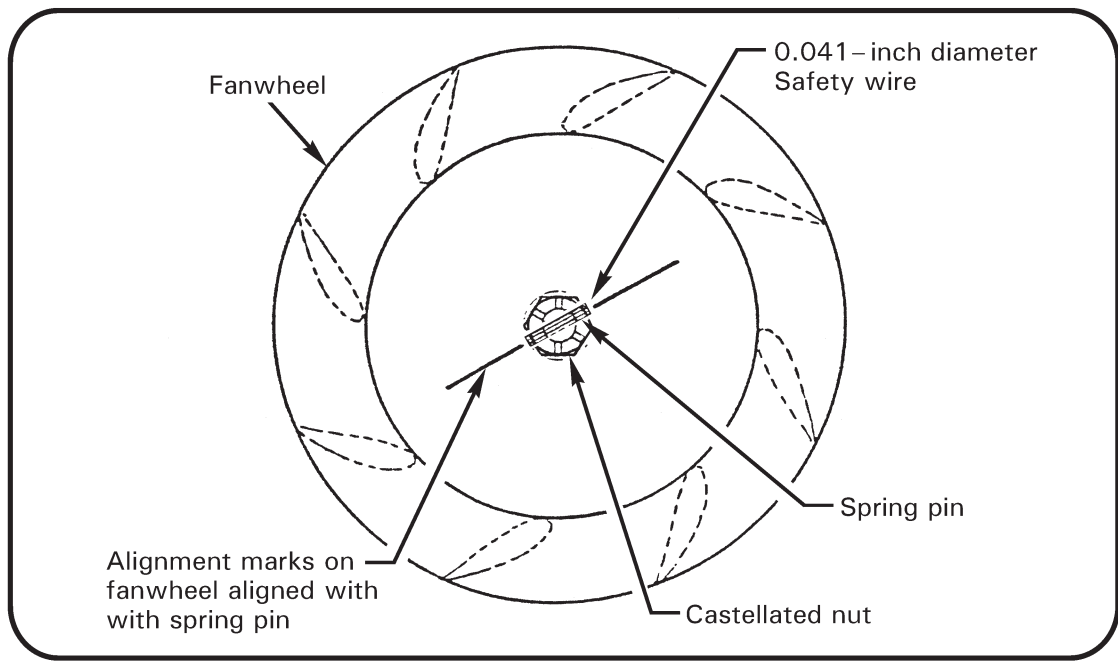

FIGURE 2-10 FANWHEEL ALIGNMENT MARKS

2.410 Inspection Procedures and Checklist (continued)

13. Scroll Area

Fanwheel Assembly: Clean and inspect fanwheel assembly for cracks and corrosion. Check leading edge of vanes for damage. Verify spring pin and fanwheel alignment marks are aligned (see Figure 2-10); remove fanwheel and inspect mating surfaces for damage if misalignment is evident.

Fiberglass Scroll: Inspect fiberglass scroll for cracks and contact marks from fanwheel. Inspect flexible seal around scroll inlet for any rips or damage. Inspect vane assembly in right upper scroll for damage. Verify drain hole is unobstructed.

Scroll Metal Inlet Lips & Gap: Verify 0.030 / 0.090 inch gap between lips and fanwheel inlet (elongate lip attach holes as required to adjust gap).

Lower Bearing Brackets: Refer to Figure 2-11. Visually inspect A185 brackets and attaching screws/rivets for evidence of fretting or looseness. If evidence of looseness is found, contact RHC Technical Support for repair instructions. On lower A185 bracket, apply torque seal in a horizontal stripe across both outboard screws/rivets to lower scroll to facilitate future inspections.

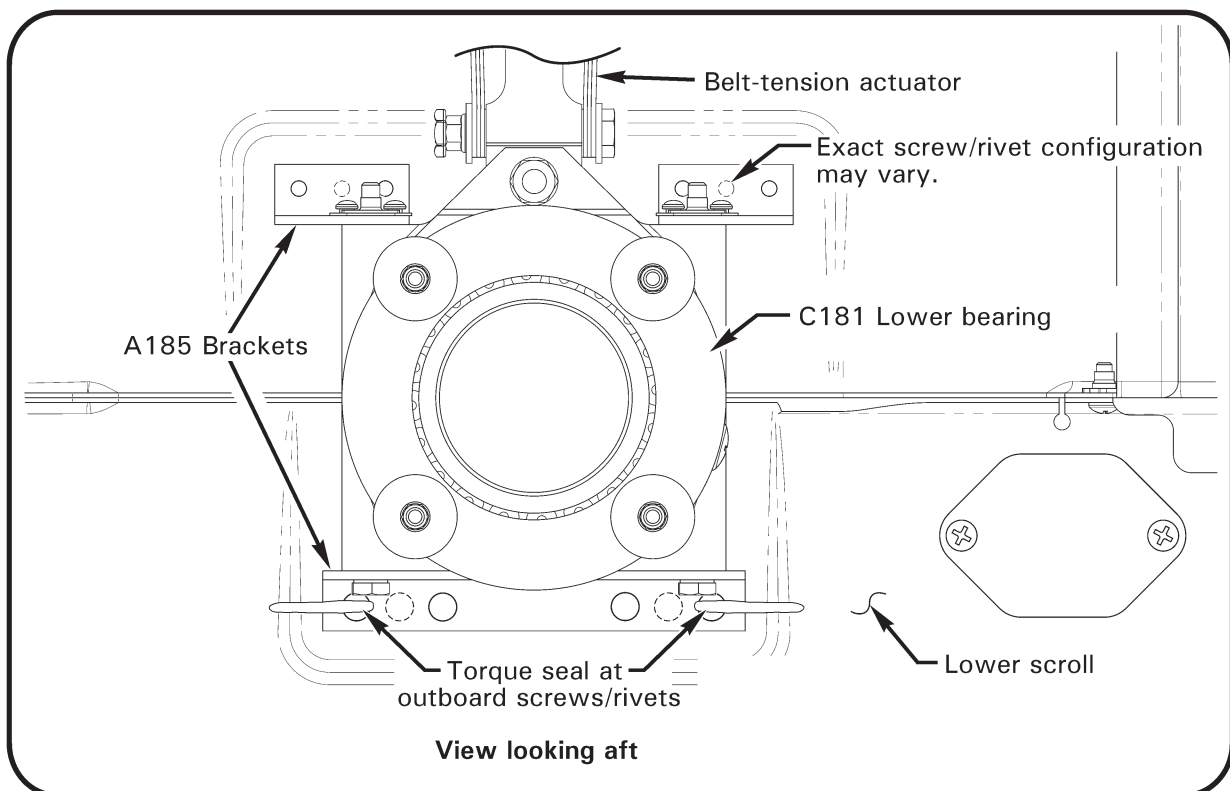

FIGURE 2-11 ACTUATOR LOWER BEARING A185 BRACKETS

2.410 Inspection Procedures and Checklist (continued)

14. Engine

Refer to § 1.101. Refer to Lycoming Operator’s Manual (P/N 60297-10 sections 4 and 5), Lycoming SI 1080, and applicable engine component manufacturer’s maintenance publications for 100-hour or annual inspection and service procedure. _____

Engine Cooling Panels: Inspect condition. Pay particular attention to panel(s) mounting oil cooler(s) and panel attached to alternator cooling hose. Verify no cracks or missing or loose fasteners. Verify security. _____

Alternator & Pulley: Inspect condition. Verify steel pulley (use magnet); aluminum pulley is not approved. Verify security. Verify electrical wiring security. _____

Alternator Belt: Inspect condition. Replace belt if there are any cracks, missing teeth, or delamination. Check tension per Lycoming Service Instruction 1129 (latest revision). Verify proper belt alignment. _____

Emergency Spare Alternator Belt: Remove if installed. _____

Alternator Cooling Hose: Inspect condition. Verify no obstructions or holes. Verify security. _____

Air Conditioning Refrigerant Lines (if installed): Verify security, no damage, and clearance to adjacent structure. Verify dust caps installed on servicing fittings at vertical firewall. _____

Air Conditioning Compressor (if installed): Verify security. _____

Air Conditioning Compressor Drive Belt (if installed): Inspect condition. Verify 4.5/5.5 pounds force applied at mid-span of belt causes 0.11/0.17 inch belt deflection; adjust as required. _____

Muffler Elbow & Tailpipe Shields: Verify no cracks in shields and shield attaching brackets. Verify clamp security. _____

2.410 Inspection Procedures and Checklist (continued)

15. Exhaust System

Muffler: Remove muffler heater shroud screws, and open shroud. Inspect muffler outer wall for cracks, deformation, and ruptures. Pay particular attention to tailpipe and riser attachment areas, welds, clamps, supports, riser flanges and gaskets. Pressurize muffler with low pressure air and inspect for leakage. Close and secure heater shroud.

16. Landing Gear

Skids and Shoes: Inspect left and right landing gear skids and skid shoes; minimum allowable shoe thickness is 0.05 inch. Verify drain holes are open (not applicable to float landing gear).

Struts and Elbows (open fairings if installed): Inspect for cracks and corrosion, especially at elbow joints. Inspect weld area at bottom of strut for cracks.

Landing Gear Fairings (if installed): Inspect for cracks and loose rivets. Verify security.

Crosstubes: Inspect, especially at elbow joints, for cracks and corrosion. With helicopter on level ground, measure distance from ground to tail skid. If dimension is less than 30 inches, one or both cross tubes must be replaced (see Chapter 5).

Landing Gear Attach Points: Check forward attach points for loose rivets, cracks, buckling, and fretting. Check bearing mounts for loose swages and worn bearings.

Utility Floats (if installed): Inspect for damage. Refer to applicable Pilot's Operating Handbook for proper inflation pressure.

Pop-out Floats (if installed) Pressure Cylinder & Valve: Inspect condition. Verify security. Verify pressure gage indicates correct pressure for ambient temperature; refer to placard on cylinder for limits.

Pop-out Floats (if installed) Inflation Manifold: Inspect condition. Verify no chafing or pinching of hoses, especially where hoses pass thru structure.

Pop-out Floats (if installed): Inspect condition of stowed floats. Verify no holes, cuts, tears, abrasion thru, or unraveling of, float covers. If cover damage is found, inflate and inspect floats. Verify all float cover snaps and hook-and-loop fasteners are properly secured. Verify float-to-skid attachment security.

NOTE

Annually apply A257-7 dry-film lubricant (see § 23-78) to float cover snap mating surfaces. Annually perform § 5.630 leak check. Every three years, perform § 5.640 emergency inflation test.

2.410 Inspection Procedures and Checklist (continued)

17. Cabin

Verify no loose equipment that might foul controls. _____

Static Ports: Inspect static ports for obstructions. If fixed utility floats are installed, verify air dam installed aft of both static ports. _____

Rear Seat-Bottom Suspension Straps: Inspect condition and security. _____

Seat Belts and Shoulder Harnesses: Inspect for fraying and broken stitching. Check inertia reels for proper operation by pulling harness quickly to verify locking function. Check buckles for proper operation. Check belt and reel attach points for security. _____

NOTE
TSO tag not required on factory installed harnesses.

Heated Seats (if installed): Perform heated seats inspection per § 15.240 Part D. _____

Cyclic Guard (if installed): Inspect condition of cyclic guard. Inspect all welds for cracks. Verify no corrosion. Verify security and proper operation. _____

Windows: Minor damage that does not impair pilot’s visibility or indicate impending structural failure is acceptable. For cracks and crazing adjacent to windshield retainer strips, refer to § 2.580. _____

Acceptable damage includes:

a. One nick, not more than 0.010 inch deep and occupying an area not larger than 0.25 by 0.50 inch per square foot. _____

b. Scratches not more than 0.010 inch deep and 5 inches long. _____

c. Any surface defect such as small spots or stains that can be removed with light polishing. _____

d. Minor polarization faults in small areas of windshield near edges. _____

Skin: Inspect skin for damage. Inspect for loose rivets, indicated by cracked paint and/or black residue around heads. _____

Doors: Inspect for cracks around hinges and latches. Check vents for operation. Ensure hinge pins are secured with cotter pins. Check tightness of hinge mounting screws. Verify proper operation of door latching and locking mechanisms. _____

Chin Drains (R44 Clipper): Verify no obstructions. _____

2.410 Inspection Procedures and Checklist (continued)**18. Special Equipment (if installed)**

Peak Beam Searchlight: Check for proper operation. Align beams by focusing both lights to smallest spot possible and shining against a wall at least 100 feet away. Verify both spots hit same point within one foot. _____

Nose Gimbal and Monitors: Turn power on and verify infrared units complete cool down sequence in manufacturer's recommended time. Verify gimbal steers smoothly in azimuth and elevation. Check focus and zoom of infrared/video. Check for clear images on monitors. Verify retractable monitor retracts without interference. _____

Spectrolab Searchlight: Verify light starts and cooling fan operates. Verify searchlight steers smoothly in azimuth and elevation. For slaved units, turn on slaving and verify light follows nose gimbal approximately. _____

FM Radios: Verify radios transmit and receive properly and control head programs radios properly. _____

Video Tape Recorder: Verify all video tape recorder modes operate properly and remote control correctly controls modes. _____

Overhead Light: Verify overhead light on/off. _____

Transmit and Intercom Switches: Verify proper operation of special transmit and intercom switches. _____

Talent Light: Verify talent light on/off, acceptable friction. _____

Micro Cameras: Verify all micro cameras are selectable from video switcher and produce focused, upright images on monitors. _____

TV Tuner: Verify TV tuner receives broadcasts (video clear on monitors, audio clear in headset). _____

Microwave Antenna: Verify omnidirectional microwave antenna extends/retracts properly. Verify up/down indicator lights function properly. _____

Electromagnetic and Radio Frequency Interference: With all special equipment turned on, check for EMI/RFI with tach, COM, intercom, compass, or other systems. _____

2.410 Inspection Procedures and Checklist (continued)

19. Life-Limited Parts, Additional Component Maintenance, ADs, & SBs

Life-Limited Parts: Refer to helicopter maintenance records and § 3.300. Replace life-limited parts as required. Verify components installed have sufficient time remaining for projected operations. _____

Additional Component Maintenance: Refer to helicopter maintenance records and § 1.102. Replace components scheduled for 12-year service, overhaul or replacement as required. Replace engine and accessories scheduled for maintenance as required. Verify components installed have sufficient time remaining for projected operations. _____

Airworthiness Directives: Verify applicable airframe, engine, and accessory Airworthiness Directives (ADs) have been performed according to AD compliance procedures. Some aircraft may be affected by ADs that require recurring inspections at less than 100-hour or annual intervals. Recent U.S. Airworthiness Directives are available online at www.faa.gov.

Service Bulletins: Verify applicable airframe, engine, and accessory Service Bulletins (SBs) have been complied with according to manufacturers' instructions. Some aircraft may be affected by SBs that require recurring inspections at less than 100-hour or annual intervals. RHC Service Bulletins are available online at www.robinsonheli.com, under the Publications tab. _____

20. Required Documents and Placards

Documents: Check that required documents (Airworthiness Certificate, Registration, applicable Radio Station License, applicable Pilot's Operating Handbook, Equipment List/Weight & Balance Data) are on board, legible, and current. _____

Placards: Verify required placards are properly installed, legible, and current. Refer to applicable Pilot's Operating Handbook Section 2 for placard requirements. _____

21. Inspection and Access Covers

Foreign Objects Removed: Verify all tools, loose hardware, rags, and other foreign objects are removed from helicopter. _____

Covers Closed and Secure: Install/close all inspection and access covers removed in preceding steps. Verify security of all access covers. _____

Clipper I Air Box Sealed: Ensure air box cover perimeter is sealed with aluminum tape (Clipper I models only). _____

2.410 Inspection Procedures and Checklist (continued)**22. Maintenance Records**

Maintenance Records: Verify maintenance records are accurate, legible, and complete. Enter maintenance performed (such as part replacement, equipment adjustments, servicing, and lubrication) and inspection data. Data must include a description of (or reference to data acceptable to the Administrator) the work performed, date, helicopter total time in service, signature, certificate type and certificate number of person approving aircraft for return to service. _____

SHEAVE ALIGNMENT LEFT: _____

SHEAVE ALIGNMENT RIGHT: _____

TRDS RUNOUT: _____

CHECKLIST COMPLETE:

Mechanic's signature: _____ Date: _____

Intentionally Blank

2.500 SPECIAL INSPECTIONS

2.501 Upper and Lower Clutch Actuator Bearings Inspection

The actuator upper bearing is located on the clutch shaft, and the actuator lower bearing is located on the fanshaft. Failure of either actuator bearing in flight could cause loss of power to rotor system and result in a serious accident. Refer to Section 2.110 for general indications of bearing failure. In addition, just before failure of an actuator bearing, the clutch light may flicker (on and off in less than one second) constantly or illuminate for longer than normal in-flight retensioning time of up to 8 seconds, then off). Flight should not be resumed until cause of abnormal clutch light illumination has been determined.

Perform the following bearing inspections whenever an actuator bearing discrepancy is suspected or fanwheel is removed:

2.502 C181 Lower Bearing Inspection

1. Remove scroll and fanwheel per Section 6.210.
2. Support clutch drive shaft aft of sheave. Disconnect lower end of belt tension actuator from bearing housing.
3. Rotate bearing housing with finger tips. Verify no roughness, scraping or excessive looseness (0.010 inch maximum axial play). Verify no seal damage and no heat damage. Lubricate bearing per Section 1.140.
4. Carefully inspect inner race bearings on fanshaft. Forward bearing inner race is torque-striped to fanshaft two places 180 degrees apart; cracked or broken torque stripes indicate movement. No movement or fretting is allowed between inner race and fanshaft. Verify no distortion due to bearing outer races rotating in housing. Replace fanshaft & bearing assembly if indications of movement are noted.
5. Reinstall fanwheel per Section 6.220.
6. Check and adjust fanwheel dynamic balance per Section 6.240.

| 2.503 C184 Upper Bearing Inspection

1. Disconnect lateral centering strut from left side of bearing housing.
2. Disconnect bearing housing from actuator. Run actuator to its full disengage position by adjusting actuator down-limit screw upward. Refer to Figure 7-15. Do not allow upper and lower scissors' attaching screw heads to contact each other.
3. Rotate bearing housing and check for sound or feel of any roughness, scraping, or excessive looseness. Verify no seal damage, loss of lubricant or heat damage.
4. Carefully inspect inner races of bearings on clutch shaft. Aft bearing inner race is torque-stripped to clutch shaft two places 180 degrees apart; cracked or broken torque stripes indicate movement. Verify no fretting between bearing inner races and shaft. Verify no distortion due to bearing outer race(s) rotating in bearing housing. Remove bearings and inspect bearing and shaft if indications of movement are noted.
5. Connect centering strut and actuator to bearing housing. Adjust actuator down-limit stop screw so there is a delay of less than 5 seconds between clutch engagement and rotor turning during start-up.

2.507 V-Belt Inspection

If any of the following conditions are observed, replace V-Belts in a matched set per Section 7.280.

1. Bottom of belts cracking.

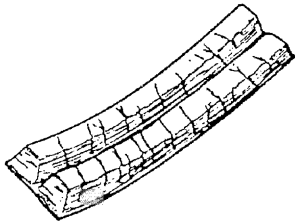

CAUSE	REMEDY
Belt slipping causing heat build-up and gradual hardening of undercord.	Return actuator to RHC for servicing.

2. Top of tie band frayed or damaged.

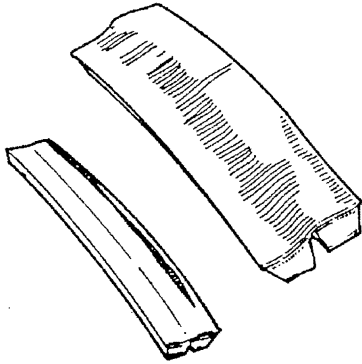

CAUSE	REMEDY
Surrounding structure interfering with normal operation of belt.	Reposition affected sheave for proper clearance and align sheaves per Section 7.230.
Foreign material contacting belt.	Remove foreign material

3. Top of tie band blistered or perforated.

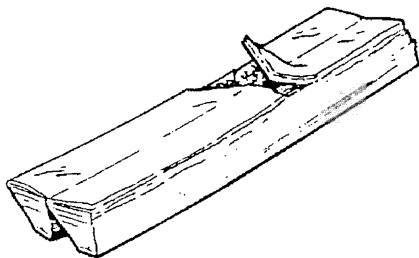

CAUSE	REMEDY
Foreign material accumulating between belts.	Check for and remove foreign material.

FIGURE 2-12 V-BELT DISCREPANCIES

2.507 V-Belt Inspection (cont'd)

4. BELT CUT ON BOTTOM

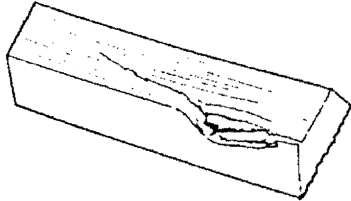

<u>Cause</u>	<u>Remedy</u>
Belt ran over sheave and came off, or belt forced over sheave flange during installation without proper slack.	Check belt tension per Section 7.283 and upper sheave alignment per Section 7.230.
Foreign material fell into belt drive making belt come off.	Remove foreign material if any. Install new belts properly per Section 7.280

5. BELT RIDING OUTSIDE SHEAVE GROOVE

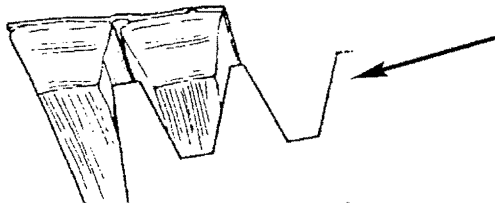

V-belt has jumped one groove forcing belt out of sheave.

CAUTION

If belt condition shown is allowed to run in specified condition, failure would progress as shown below.

<u>Cause</u>	<u>Remedy</u>
One belt separated from tie band	Both belts separated from tie band



<u>Cause</u>	<u>Remedy</u>
Improper belt tension, misalignment of sheaves and/or foreign object struck belt forcing it from its normal path.	Replace V-belts per Section 7.280; align upper sheave per Section 7.230.



FIGURE 2-12A V-BELT DISCREPANCIES

2.508 Lower Sheave V-Belt Wear Pattern Inspection

Observe wear patterns in paint primer in all eight grooves of lower V-belt sheave. Wear patterns on both sides of all eight grooves should appear very similar. Wear patterns which vary in width less than a 3-to-1 ratio groove to groove are acceptable.

If wear pattern is noticeably different from groove to groove, inspect sheave grooves for roughness or excessive wear and replace V-belts per Section 7.280. If wear patterns are all similar and alignment and condition of belts and sheaves are satisfactory, no further action is required.

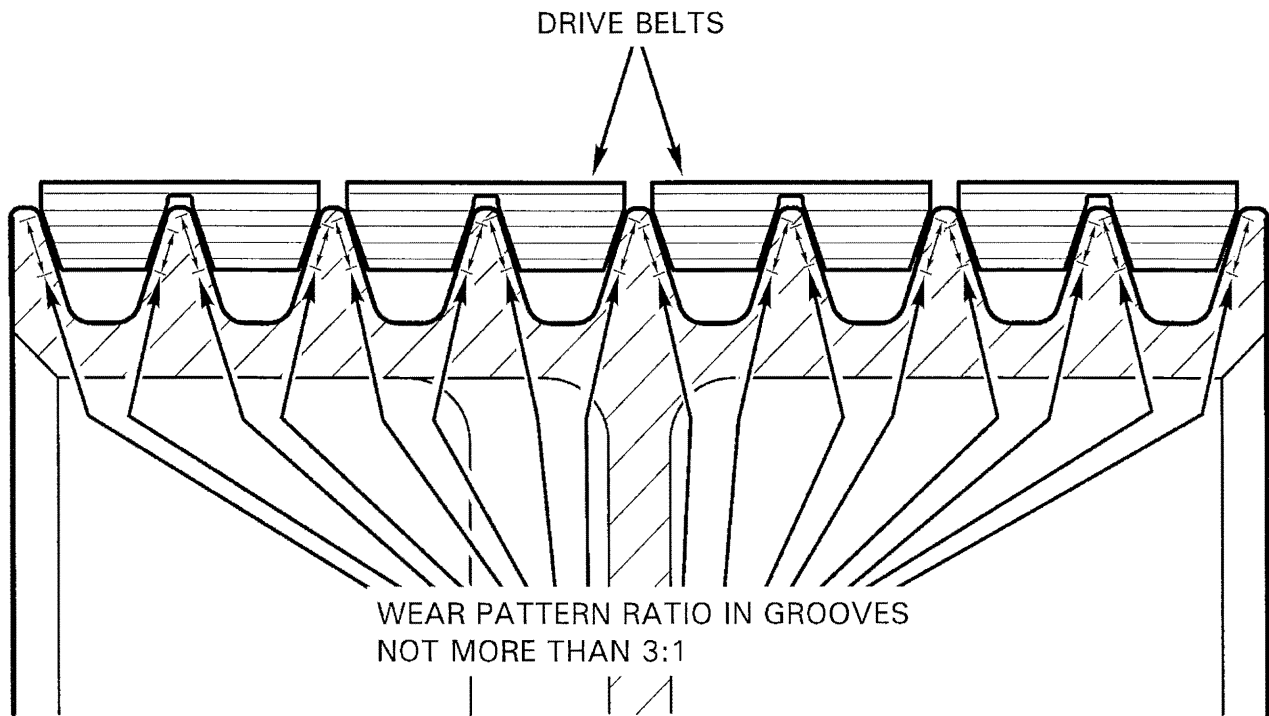

FIGURE 2-13 LOWER SHEAVE V-BELT WEAR PATTERN

| Intentionally blank

2.510 Tail Skid Strike

The tail skid strike inspection is listed in two parts, A and B. Part A concerns scuffing of tail skid. Part B is concerned with bending or breaking of tail skid and/or buckling of lower vertical stabilizer.

- A. If evidence of scuffing is found on tail skid, inspect helicopter as follows:
 - 1. Visually inspect tail rotor blades for evidence of solid object or ground contact. If tail rotor damage is found, inspect tail rotor for strike per § 2.520. _____
 - 2. Visually inspect lower vertical stabilizer for cracks and loose rivets at tail skid and lower vertical stabilizer attach points. _____
 - 3. Visually inspect tail rotor guard for bending or cracking at attach points. _____
 - 4. Visually inspect empennage assembly attach points for buckling, loose rivets, or cracking. _____
 - 5. Visually inspect tailcone assembly for buckling and loose attach bolts. _____
 - 6. Visually inspect upper frame for yielding. _____

- B. For tail skid bending or breakage, or buckling of lower vertical stabilizer, perform the following inspections in addition to those listed in Step A.
 - 1. Measure tail rotor drive shaft runout per § 7.340. _____
 - 2. Remove tailcone per § 4.300. Visually inspect (8) tailcone mounting holes [(4) tailcone & (4) upper frame] and verify no elongation of holes (0.454-inch diameter maximum). _____
 - 3. Remove empennage assembly per § 4.600. Remove tail rotor gearbox per § 7.410. _____
 - 4. Perform § 2.595 Inspection After Stabilizer Damage. _____
 - 5. As applicable, visually inspect F044-1 mount or C044-1 horizontal stabilizer attach points and verify no elongated holes (0.386-inch diameter maximum), loose rivets, or buckling. _____
 - 6. Remove lower vertical stabilizer per § 4.620. Visually inspect (10) attach points. Verify no elongated holes (0.266-inch diameter maximum bolt holes), buckling, cracks, or loose rivets. _____
 - 7. Remove tail rotor guard per § 4.400. Remove D082-1 mount. Visually inspect guard, mount, & blocks; verify no deformation & no elongation of attach holes. _____

Intentionally Blank

Intentionally Blank

2.520 Tail Rotor Strike

Tail rotor strike inspection is listed in two parts, A and B. Part A concerns damage received by a tail rotor blade due to contact with a small stone, tall grass, or some small object contacting rotor blade in free air. Part B is concerned with sudden stoppage of tail rotor due to ground or solid object contact causing bending or shearing of a tail rotor blade or blades.

A. Contact with Small Stone, Tall Grass, or Other Small Object in Free Air

- 1. Inspect blade(s) per § 30-30. _____
- 2. Check tail rotor drive shaft run-out per § 7.340. If run-out exceeds 0.025 inch at any location, shaft must be replaced or repaired. _____

B. Sudden Stoppage of Tail Rotor due to Ground, or Solid Object Contact Causing Bending or Shearing of Blade(s)

- 1. Perform inspections per Part A. _____
- 2. Remove tail rotor assembly per § 30-10 and tail rotor gearbox per § 7.410 and return to RHC for repair, or replace. _____
- 3. For D196-1 aluminum shaft assembly only (if installed): Replace next higher assembly D224-2 shaft assembly. _____
- 4. For C196-1 steel shaft assembly only (if installed):
 - a. Check tail rotor drive shaft run-out per § 7.340. If run-out exceeds 0.025 inch at any location the shaft must be replaced. _____
 - b. Verify no nicks, scratches, twisting, or dents. Nicks and scratches may be polished out to a maximum of 0.003 inches deep. Replace shaft if twisted or dented. _____
 - c. Strip paint back at least 2 inches from welds at forward end of drive shaft and magnetic particle inspect (refer to § 23-41) stripped area; replace shaft if cracked. _____
- 5. Replace aft and intermediate flex plates. _____
- 6. Visually inspect tailcone & empennage for evidence of a tail rotor blade strike. _____
- 7. Visually inspect main rotor system for collateral damage. _____

2.530 Main Rotor Strike

The main rotor strike inspection is listed in two parts A and B. Part A concerns contact of main rotor blades with object in free air such as small stones, brush, small birds, etc. Part B is concerned with sudden stoppage of main rotor due to ground or solid object contact.

- A. If main rotor blade has contacted a small object in free air such as small stones, brush, small birds, etc the main rotor blades should be inspected as follows:
 - 1. Main rotor blades should be inspected for evidence of nicks, scratches, dents, etc. per Section 9.130. _____
 - 2. Visually inspect trailing edge of blade for evidence of buckling or bending. This will be most evident near root of blade. _____

CAUTION

If evidence of buckling is found on a main rotor blade it will be considered to have sudden stoppage and sudden stoppage inspection must be used to inspect the entire rotorcraft

- B. If main rotor blade or blades have contacted ground or a solid object, they must be inspected for sudden stoppage. Sudden stoppage is evident when buckling or bending of the main rotor blades has occurred. Use the following procedure for inspecting rotorcraft after main rotor sudden stoppage has occurred:
 - 1. Check the tail rotor drive shaft run-out Section 7.340. _____
 - 2. Remove the following components and return to a Robinson Helicopter Company approved overhaul facility for inspection and/or repair.
 - C005 Main Rotor System _____
 - C006 Main Rotor Gearbox _____
 - C018 Clutch Assembly _____
 - C947-1 Forward Flex Plate _____
 - C907 and C908 Yokes _____
 - 3. Inspect engine for sudden stoppage per engine manufacturer's instructions. _____
 - 4. Dye penetrant inspect upper rotating swashplate for cracks and/or deformation. _____

2.540 Rotor/Engine Overspeed

Overspeed inspections are determined by severity of overspeed. Inspection is listed in three parts: A, B, and C. Part A concerns inspection of rotor system due to overspeed between 108% and 114%. Part B is concerned with inspection of rotor system due to overspeeds at or above 114%. Part C is concerned with engine overspeed inspections.

A. For rotor overspeeds between 108 and 114%:

NOTE

Refer to Part C if a power-on overspeed occurs.

1. Check main rotor and tail rotor dynamic balance. Compare pre-overspeed and post-overspeed balance.

CAUTION

Any change in rotor dynamic balance greater than 0.3 ips requires inspection per Part B.

2. Remove main rotor blades. Drain pitch bearing housings. Remove outer blade boot clamps and fold boots away from pitch horns. Rotate spindles to verify no brinelling of pitch bearings.

NOTE

Bearings have a high preload; slight drag is normal. If roughness is evident, return blade and spindle assembly to RHC-authorized overhaul facility for repair.

3. Visually inspect main and tail rotor blades.
4. Check tail rotor drive shaft run-out per Section 7.340.

B. If an overspeed at or above 114% is reported or suspected or if balance changes or pitch bearing roughness is evident, perform following inspections in addition to Part A.

NOTE

Refer to Part C if a power-on overspeed occurs.

1. Perform inspection per Part A.
2. Check coning hinge bolts for evidence of bending. Replace any bent bolts.
3. Coning hinge bolts, washers, and journals must be magnetic particle inspected. Replace any cracked bolts, journals or washers.

2.540 Rotor/Engine Overspeed (continued)

4. Visually inspect hub and dye penetrant inspect any areas suspected of having cracks. Dye penetrant inspections are performed using instructions supplied by manufacturer of penetrant kit.
 5. Reinstall blades and check balance. If a change in balance is evident, rotor system should be returned to an approved RHC overhaul facility for inspection and/or repair.
- C. Determine percent engine overspeed from engine tachometer indication using following formula:

$$\text{Percent engine overspeed} = \frac{\text{Engine tachometer indication} \times 2665}{2800} - 100$$

NOTE

102% engine tach indication equals 2718 actual engine RPM.
The engine is rated at 2800 RPM.

Refer to Lycoming Service Bulletin 369 (current revision) for engine overspeed inspection requirements.

2.550 Hard Landing

The hard landing inspection is listed in two parts: A and B. Part A concerns yielding (bending) of the cross tubes due to hard landing such as hovering autorotations or run-on landings that do not apply side loads to the landing gear. Part B is concerned with hard landings that, in addition to yielding of cross tubes, has yielding of steel tube frames or fuselage primary structure.

NOTE

Side loads show up in the airframe as buckles and bent steel tube structure.

2.550 Hard Landing (continued)

- A. Yielding of cross tube due to hard landing with no side loads:
1. Check tail rotor drive shaft run-out per § 7.340.
 2. Visually inspect main rotor blades for oil canning of skins and buckling. See § 9.130 for inspection and repair of main rotor blades.
 3. Check landing gear cross tubes for yielding beyond serviceable limit. Place rotorcraft on level ground, and measure from tip of tail skid to ground. If less than 30 inches, one or both cross tubes must be replaced.
 4. Check and adjust sheave alignment per § 7.230.
 5. Inspect front seat structure for yielding.
 6. Inspect aft seat structure for yielding. Open aft seat bottoms and verify no gap around foam spacer at aft end of seat bottom structure.
- B. If yielding of steel tube frame(s) OR fuselage has occurred, inspect rotorcraft as follows:
1. Perform Part A inspections.
 2. Visually inspect steel tube frames for yielding. Using 10X magnification, visually inspect frames within 1 inch of welds for cracks. Pay particular attention to aft vertical strut members of lower steel tube structure. Replace cracked or yielded frame(s).

NOTE

No frame yielding is allowed.

3. Visually inspect fuselage, landing gear attach points, and firewalls for buckling or cracks.

NOTE

Vertical firewall attach points for engine mount struts are susceptible to cracks due to hard landings.

4. Visually inspect tailcone for buckling or loose rivets.
5. Visually inspect landing gear skid tube-to-strut attach points for bending and cracks.
6. Hard landings can be accompanied by tail skid strikes, tail rotor strikes, main rotor blade strikes, etc. To inspect for these conditions, refer to the appropriate portion of § 2.500. Minor sheet metal repairs to cabin are permitted. Any cracks, yielding or buckling in steel tube structure or tailcone are cause for replacement. Major defects may be factory-repaired by replacement of parts and assemblies.

Intentionally Blank

| 2.560 [Reserved.]

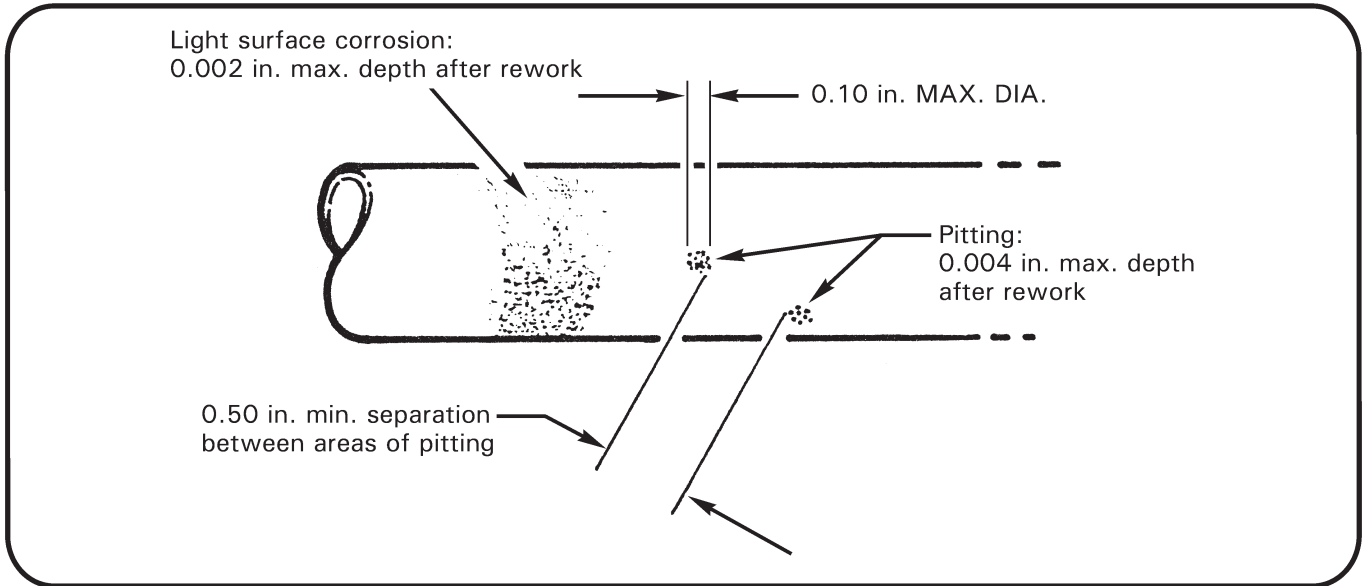

FIGURE 2-16 UPPER FRAME CORROSION REMOVAL LIMITATIONS

2.561 Corrosion on C020 Upper Steel Tube Frame

1. Polish out corrosion on steel frame tube members.
 - a. Polish out light surface corrosion on frame members using Scotchbrite or 400 grit wet-or-dry sandpaper subject to dimensional limitations shown in Figure 2-16.
 - b. Polish out corrosion pitting using 320-grit wet-or-dry sandpaper subject to dimensional limitations shown in Figure 2-16.

NOTE

For large areas of corrosion, it may be necessary to remove entire upper frame from aircraft and strip off paint to adequately determine extent of damage.

2. Prime bare metal with a good quality zinc chromate or epoxy primer.
3. Refinish area with gray epoxy top coat or equivalent.

2.570 Volcanic Ash Recommendations

Flight in visible volcanic ash conditions ("ash cloud") is detrimental to the helicopter and should be avoided. If helicopter has been operated in visible volcanic ash conditions:

1. Refer to Lycoming SI 1530. Wearing suitable protective equipment, use vacuum cleaner followed by compressed air to remove as much debris as possible. Do not use compressed air near main rotor blade drain holes.
2. Refer to applicable Pilot's Operating Handbook (POH) Section 8. Thoroughly clean, wash, and rinse helicopter, including inner circumference of drive belts.
3. Remove main rotor blade tip covers and clean blade tips.
4. Using 10X magnification, visually inspect any exposed main rotor blade skin-to-spar bond line (adhesive) for gaps (empty space between skin and spar). Blade is unairworthy if any gap, including "pin hole(s)", is detected in the bond line. Refinish blade as required.
5. Inspect condition of drive belt sheaves. Replace any sheave having corrosion pitting, flaking, wear thru metalized or anodized coatings, roughness, or sharp ridges. Replace drive belts if either sheave has sharp ridge(s) on drive belt contact surface.
6. Disconnect alternator drive belt from alternator. Spin alternator pulley by hand and verify rotor bearings and brushes operate smoothly; repair alternator as required if roughness or unusual noise is encountered (volcanic ash can enter via unfiltered cooling air). Inspect alternator and ring gear support pulleys and verify no wear steps; replace alternator belt and pulley(s) if wear steps exist. Perform Lycoming SI 1129 alternator belt tension check and adjust as required.
7. Clean air box interior and:
 - a. Inspect air filter and replace as required.
 - b. Inspect induction system downstream of air filter (a clean, white glove is beneficial). If volcanic ash is found then:
 - i. Clean induction system, disassembling as required.
 - ii. Disassemble carburetor or fuel injection servo, as applicable, inspect for internal contamination, and overhaul as required.
 - iii. Perform Lycoming SI 1191 Cylinder Compression check.
 - iv. Perform Lycoming SB 388 Procedure to Determine Exhaust Valve and Guide Condition.
 - v. Inspect spark plug condition; service as required.
 - c. On fuel injected engines, perform Lycoming SI 1275 Cleaning Fuel Injection Nozzles (volcanic ash can enter atomization screens).

2.570 Volcanic Ash Recommendations (continued)

8. Remove each magneto's distributor gear inspection plug and inspect visible internal portion for contamination; overhaul magnetos if volcanic ash is found inside (magneto vent plugs are unfiltered).
9. Inspect engine oil condition. Regardless of oil time-in-service if oil smells bad, is opaque (or is not obviously brown), or if particulates are detectable on the dipstick, change engine oil & oil filter, inspect suction screen and old oil filter, and perform Lycoming SI 1191 Cylinder Compression check if not previously accomplished in step 6.

2.580 Windshield Inspection

This section has been moved to Chapter 27 Doors and Windows.

2.590 Lightning Strike

Lightning strikes are extremely rare for helicopters operating in VFR conditions.

If a lightning strike does occur, RHC recommends performing a 100-hour inspection per § 2.400 and following recommendations for aircraft struck by lightning per Lycoming Service Bulletin No. 401.

High voltage that is well conducted through the aircraft structure will dissipate and cause minimal damage. High voltage that is not well conducted through the aircraft structure can result in excessive heat, which can bake, burn, char, or even melt certain materials. Heat damage may or may not be detectable by visual inspection. A component may not exhibit obvious damage, but temperatures above 300° F can alter the strength of some materials and thus affect a component's service life and airworthiness.

Visually inspect main rotor blades, landing gear, drive train, airframe, and flight controls thoroughly for obvious damage such as electrical arcing or burns, pitting, or cracking. Particular attention should be given to rod ends, journals, etc., where the conductive path is most susceptible. If obvious damage is detected in any of the above-mentioned systems, additional components may require replacement. Contact [RHC Technical Support](#) with detailed documentation for further guidance prior to approving aircraft for return to service.

2.595 Inspection After Stabilizer Damage

For damage to an installed C042-1 upper vertical stabilizer, C043-1 lower vertical stabilizer, and/or C044-1 horizontal stabilizer that results in denting, tearing, or cracking of stabilizer metal, or if a tail skid strike has occurred, perform the following:

1. On associated tailcone's aft C148 bulkhead, strip paint from cross-hatched surfaces shown in Figure 2-18 using § 23-71 approved materials.
2. Perform fluorescent penetrant inspection (FPI) per § 23-42 of stripped surfaces. Replace tailcone if crack is indicated.
3. Conversion coat bare aluminum per § 23-51, as required. Epoxy prime (chromated-epoxy primer preferred) & topcoat stripped surfaces per § 23-60.

NOTE

Do not apply primer or topcoat to tail rotor gearbox attachment surfaces.

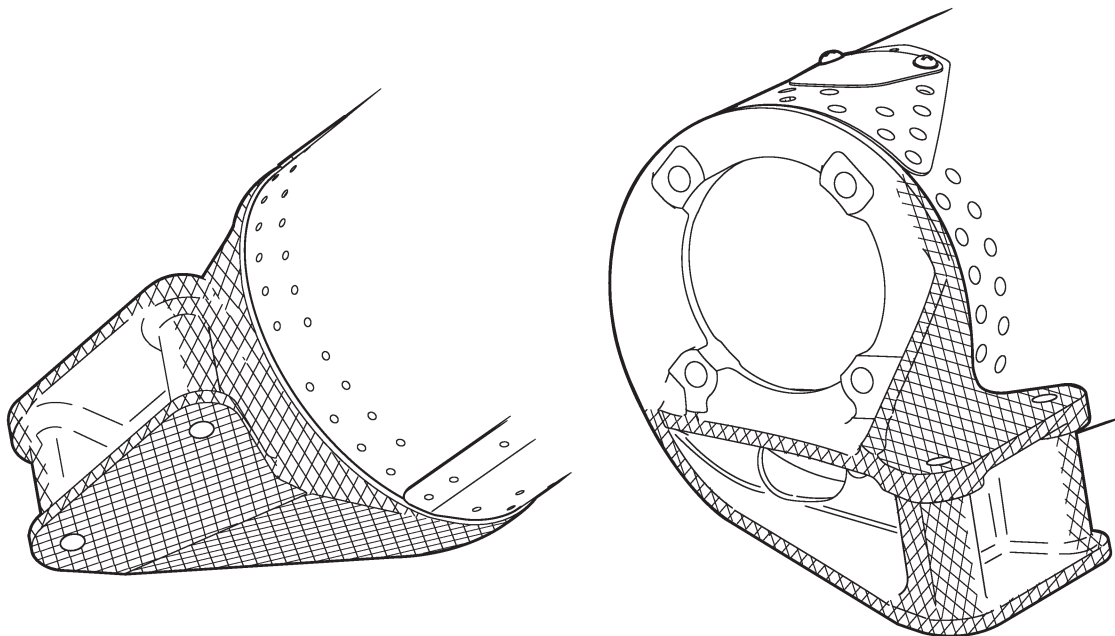

FIGURE 2-18 CROSS-HATCHED SURFACES OF TAILCONE'S AFT C148 BULKHEAD

2.600 2200-Hour/2400-Hour/12-Year Inspection**NOTE**

KI-4402 R44 2200-Hour (2400-Hour for Cadet) Inspection Kit contents and KI-4403 R44 II 2200-Hour Inspection Kit contents are available online at <https://robinsonheli.com> for review.

NOTE

12-Year Inspection is only required for helicopters that have accumulated 12 years calendar time and less than 2200 hours (R44 S/Ns 0001 thru 9999 & R44 II S/Ns 10001 thru 29999) or 2400 hours (R44 Cadet S/Ns 30001 & subsequent) time in service since new, since last 2200-hour/2400-hour inspection, or since last 12-year inspection.

1. Refer to helicopter maintenance records and § 3.300; replace life-limited parts, or next higher assemblies, as required.
2. Refer to helicopter maintenance records and § 1.102; perform additional component maintenance, as required.
3. Remove engine, engine cooling panels, fanwheel, scroll, air induction system, carburetor heat system, oil lines, and all hoses. Overhaul or inspect, as required, magnetos, alternator, and carburetor per appropriate manufacturer's maintenance publications and service bulletins.
4. Remove horizontal, both vertical, & float stabilizers, and F044 mount, as applicable. If replacement is not required, visually inspect condition. Fluorescent penetrant inspect any suspect metal areas per § 23-42. Install stabilizers per §§ 4.500 thru 4.640.
5. Inspect cross tubes per § 5.210. Remove landing gear per § 5.110.
6. Remove steel tube frames per § 4.200, and replace as required. If replacement is not required, proceed per § 1.102 Part A or B, as appropriate. Install frames per § 4.200.
7. Visually inspect cyclic stick for corrosion. If corrosion is evident: remove cyclic stick per § 8.111. Remove wiring harness. Remove paint via dry media blasting. Visually inspect and verify no cracks or corrosion. Magnetic particle inspect per § 23-41. Clean, prime, and paint per § 23-60. Install wiring harness. Install cyclic stick per § 8.111.

2.600 2200-Hour/2400-Hour/12-Year Inspection (continued)

8. For C121 push-pull tube assemblies not addressed in § 1.102: Visually inspect and verify no corrosion. If corrosion is detected, remove push-pull tube, record assembled length, remove rod ends, remove paint, and repair or replace as required. After repair, fluorescent penetrant inspect per § 23-42. Clean, prime, and paint per § 23-60. Install rod ends to previously recorded assembled length. Install push-pull tubes per Chapter 8.
9. Inspect airframe wiring condition. Verify no corrosion, insulation deterioration, or other damage. Verify correct wires attached to correct circuit breakers.
10. Remove main and aux tank fuel bladders per § 12-11 and § 12-21. Visually inspect; verify no cracking or delamination of rubber and rubber-to-metal joints. Visually inspect threaded inserts and fittings for damage. Pressurize to 1 psi max and check for leaks with mild soap & water mixture. Visually inspect tank structures for evidence of bladder leakage. Install bladders per § 12-11 and § 12-21.
11. Perform clutch sheave alignment per § 7.230 and intermediate flex plate shimming per § 7.330.
12. Perform main rotor flight control and blade angle rigging per § 10.110 and § 10.120.
13. Perform tail rotor flight control and blade rigging per § 10.130 and § 10.140.
14. Perform 100-hour/annual inspection per § 2.400.
15. Weigh helicopter per § 1.230.

NOTE

Extended low-power operation with new piston rings may prevent proper piston ring seating.

16. Balance tail rotor per § 10.240. Track and balance main rotor per § 10.230. Perform ground check, run up, and flight checks per §§ 2.205, 2.210, & 2.220.
17. Drain and flush main and tail rotor gearboxes per §§ 1.120 & 1.130.
18. Make appropriate maintenance record entries. Enter maintenance performed (such as part replacement, equipment adjustments, weighing, servicing, and lubrication) and inspection data. Data must include a description of (or reference to data acceptable to the Administrator) the work performed, date, helicopter total time in service, signature, certificate type and certificate number of person approving aircraft return to service.

2.610 Tail Rotor Gearbox 12-Year Maintenance

1. If installed, drain and flush C021-1 tail rotor gearbox assembly per § 1.130 steps 1 thru 11.
2. If installed, remove tail rotor gearbox per § 7.410.
3. Remove hardware securing C116-1 yoke to C545 input gear. Visually inspect yoke and replace yoke if damaged. Visually inspect input gear splines; return gearbox to RHC if splines are damaged, including wear steps. Replace input shaft seal per § 7.450 steps b) thru l).
4. Remove sight gage and clean glass. Visually inspect gear set; return gearbox to RHC if corrosion or other damage is detected. Install sight gage and special torque gage per § 23-33.
5. Replace output shaft seal per § 7.440 steps b) thru g).
6. Install tail rotor gearbox per § 7.420 steps a) thru g).
7. Remove filler-plug. Fill gearbox to center of sight gage using correct gearbox oil (refer to R44 Service Letter SL-73). Rotate rotor system by hand for several revolutions. Check gearbox oil level and adjust as required; install filler-plug and special torque per § 23-33.
8. Connect tail light and chip detector wiring to airframe harness at connectors. Turn battery on. Verify tail light illuminates with position lights turned on. Depress push-to-test TR CHIP button and verify TR CHIP caution light illuminates. Turn battery off.
9. Install tail rotor per § 30-10 Part A or B, as applicable.

2.620 Fanwheel 12-Year Maintenance

1. If installed, remove D174-2 fanwheel assembly per § 6.210.
2. Mark fanwheel assembly parts, including balancing hardware, for identical reassembly.
3. Refer to Figure 2-19. Loosen bolts securing C187-3 cone assembly and C186-1 hub to fanwheel. Verify hub axial play does not exceed 0.020 inch with hub bolts loose and NAS6603 bolts tight.
4. Remove hardware securing cone assembly, hub, and C178-2 spacer(s) to fanwheel and remove parts, noting relative locations for identical reassembly.
5. Visually inspect all components for obvious damage. Verify no elongation of fastener holes. Replace parts as required.
6. Assemble fanwheel wet with approved primer (chromate primer preferred; refer to § 23-75) between all clamping surfaces; while primer is wet, special torque D210 nuts per § 23-33. Apply B270-21 protectant to threads and tip of B660-1 bolts, if installed.

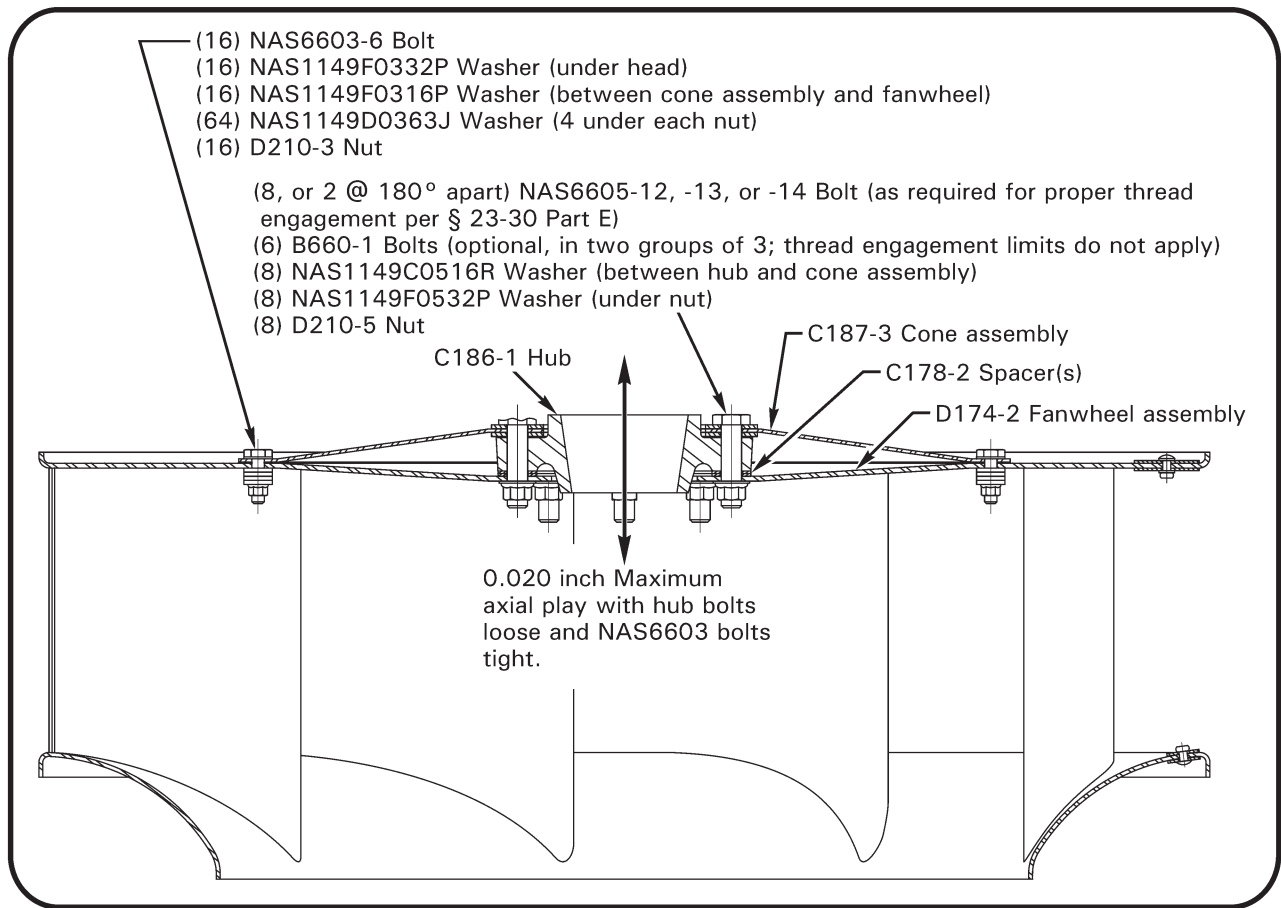

FIGURE 2-19 D174-2 FANWHEEL ASSEMBLY

2.630 C258-5 Main Rotor Pitch Link Assembly Inspection

1. Temporarily mark each pitch link and associated swashplate ear with unique color. Record overall lengths of both links.
2. Remove pitch links.
3. R44 Service Letter SL-58 refers. Disassemble pitch links, keeping parts from each link separate from the other.
4. Evaluate rod ends per § 2.122 and replace as required.
5. Visually inspect parts with 10X magnification for obvious damage. Replace damaged parts.
6. Visually inspect interior of barrels with borescope for obvious damage. Replace damaged barrels.
7. Assemble pitch links using a light coat of A257-2 or -22 oil on threads and adjust to recorded lengths. Torque jam nut & adjacent palnut per § 23-32. Special torque self-locking 21FKF-813 jam nut per § 23-33.
8. Install pitch links to associated swashplate ear and, if installed, main rotor blade. Torque fasteners per § 23-32 and torque stripe per Figure 2-1.

2.640 Swashplate Assembly 12-Year Inspection

1. Remove swashplate assembly per § 8.411.
2. Remove both pitch links and upper A205-7 fork assembly from swashplate.
3.
 - a. If swashplate is P/N C017-6 Rev AD or subsequent, proceed to step 4.
 - b. If swashplate is P/N C017-4, or is P/N C017-6 Rev AA, AB, or AC, AND
 - “B900-13 MOD” is marked adjacent to swashplate data plate, proceed to step 4.
 - “B900-13 MOD” is NOT marked adjacent to swashplate data plate, perform R44 Service Letter SL-76A.
4. Refer to Figure 1-2B. Remove (10) NAS1352 screws (with washers) securing C206-2 & C200-3 retainers to upper swashplate. Remove both retainers and C219-3 spacer and set aside.
5. Remove inner screws securing sleeve to lower swashplate. Remove sleeve, shims, and ball and set aside.
6. Using a 0.006 inch feeler gage, gently pry up outer edge of upper C217-1 seal and expose top ball bearing. Discard upper seal.
7. Clean all parts, including C203-5 yokes.
8. Visually inspect cleaned parts with 10X magnification, to include blind screw-holes in upper & lower swashplates, for obvious damage. Replace swashplate assembly if damage is detected on either upper or lower swashplate. Replace damaged parts.
9. Perform swashplate tilting friction adjustment per § 8.413 step 4.
10. Lubricate swashplate bearings per § 1.195 steps 7 thru 11. Install new upper seal during procedure.
11. Remove rod end from upper fork. Using non-metallic tools, remove majority of sealant in threaded hole of fork. Visually inspect parts with 10X magnification for obvious damage. Replace damaged parts. Assemble upper fork assembly and adjust pivots' center-to-center dimension to 3.85 ± 0.03 inches. Standard torque jam nut & palnut per § 23-32 and torque stripe per Figure 2-1. Fill exposed cavity with B270-13 sealant.
12. Remove lower A205-7 fork assembly from non-rotating scissors and clean. Remove rod end from lower fork. Visually inspect parts with 10X magnification for obvious damage. Replace damaged parts. Assemble lower fork assembly and adjust pivots' center-to-center dimension to 3.70 ± 0.03 inches. Standard torque jam nut & palnut per § 23-32 and torque stripe per Figure 2-1. Install lower fork on C204-2 arm and standard torque bolt per § 23-32. Install palnut, standard torque per § 23-32, and torque stripe per Figure 2-1.
13. Install swashplate assembly per § 8.412.

2.650 Landing Gear Assembly Inspection

A. 12 Year Inspection

1. Remove left skid tube, and remove rain cap and skid extension from tube.
2. Remove fasteners securing struts to cross tubes. Using a twisting motion, remove left struts from cross tubes.
3. Remove right skid tube, and remove rain cap and skid extension from tube.
4. Using a twisting motion, remove right struts from cross tubes.
5. Clean cross tubes, struts, and skid tubes.
6. Visually inspect interior of struts with borescope (or similar) for obvious damage. Visually inspect exterior of struts using minimum 3X magnification for obvious damage. Any corrosion on, or adjacent to, a weld requires corrosion & paint removal followed by MPI. Upon favorable MPI results, apply § 23-76 powder coat.
7. Refer to § 5.300. Visually inspect interior of skid tube with borescope (or similar). Visually inspect exterior of parts using minimum 3X magnification. As required, touch-up coatings with § 23-75 primers and § 23-77 paints.
8. Visually inspect interior of cross tubes with borescope (or similar) for obvious damage. Visually inspect exterior of cross tubes using minimum 3X magnification for obvious damage. As required, touch-up coatings with § 23-75 primers and § 23-77 paints.
9. Assemble landing gear.
10. Install landing gear per § 5.120.

B. 2200-Hour/2400-Hour Inspection

1. Remove left skid tube, and remove rain cap and skid extension from tube.
2. Remove fasteners securing struts to cross tubes. Using a twisting motion, remove left struts from cross tubes.
3. Remove right skid tube, and remove rain cap and skid extension from tube.
4. Using a twisting motion, remove right struts from cross tubes.
5. Remove exterior paint from cross tubes, struts, and skid tubes.
6. Magnetic particle inspect steel struts and fluorescent penetrant inspect aluminum cross tubes, elbows, and skid tubes per §§ 23-41 and 23-42. Clean, prime, and paint per § 23-60.
7. Assemble landing gear.
8. Install landing gear per § 5.120.

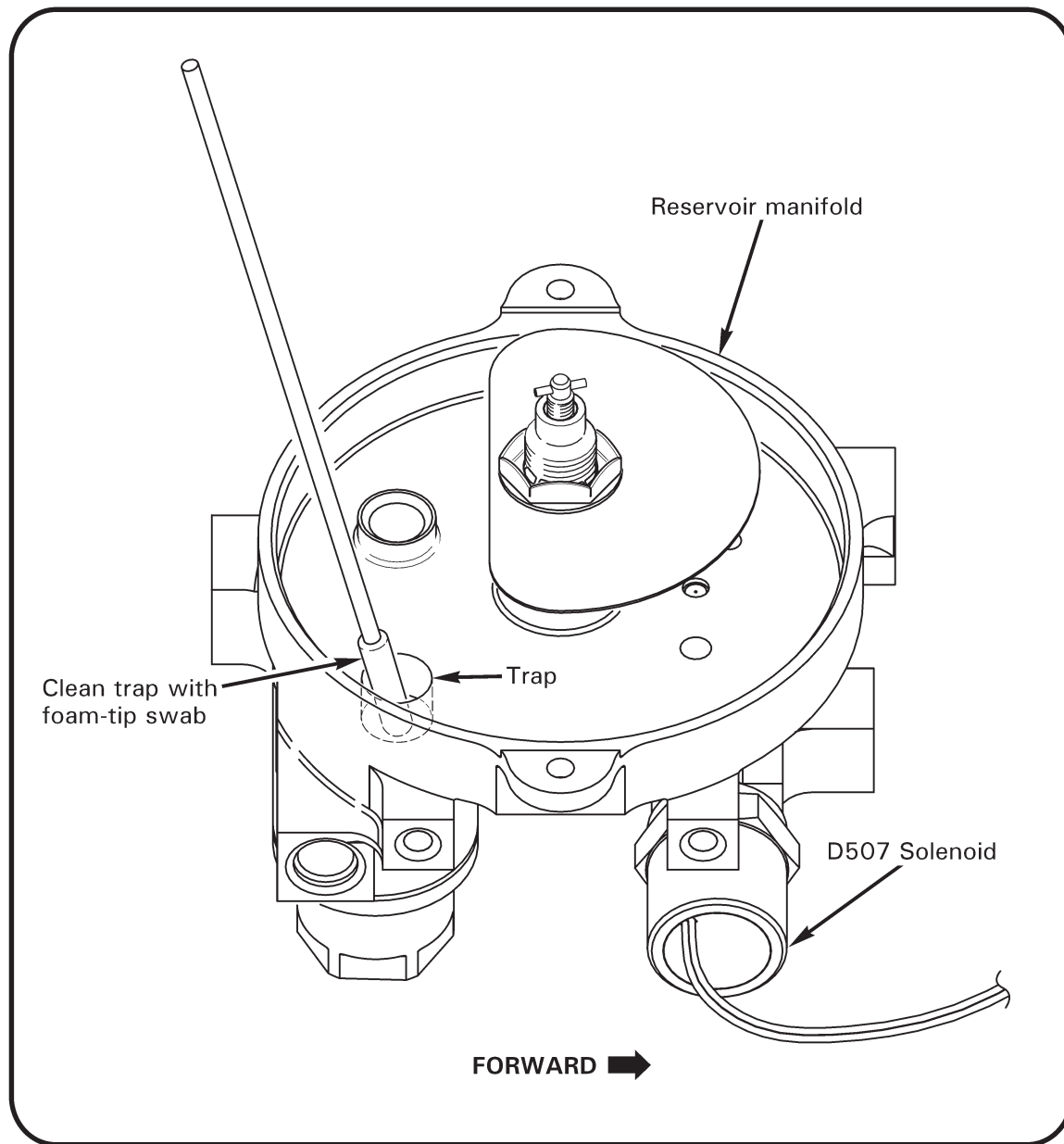

FIGURE 2-20 HYDRAULIC RESERVOIR INSPECTION

2.660 Hydraulic Reservoir 12-Year Inspection

1. Remove reservoir filler-vent.
2. Place a one-liter container beneath D500-1 hydraulic pump. Remove caps from pump suction and pressure T-fittings. Allow fluid to drain thru suction hose into container. Loose filter cap, allow fluid in pressure hose to drain, then tighten filter cap.
3. Remove and retain both NAS6603-3 bolts & hardware securing D486-1 (finned) housing to lower, manifold portion of D211 reservoir.

2.660 Hydraulic Reservoir 12-Year Inspection (continued)

4. Lift off D486-1 housing from manifold (there will be some resistance due to o-ring packing).
5. Refer to Figure 2-20. Avoid disturbing orientation of sheet-metal baffle. Suction remaining fluid from manifold using suitable, clean, plastic tube (do not use metal tool). Using lint-free wipe, clean exposed interior of manifold. Wipe out any residue from trap (blind hole) with clean, foam-tip swab.
6. Inspect interior of manifold for corrosion. Replace reservoir assembly if corrosion is detected.
7. Using lint-free wipe, clean interior of D486-1 housing and visually inspect. Replace housing if corrosion is evident.
8. Lubricate new MS28775-240 o-ring packing with A257-15 fluid and install in groove at base of D486-1 housing.
9. Install D486-1 housing on manifold, align sight gage with bolt hole adjacent solenoid, and fully seat housing by hand. Install NAS6603-3 bolts & hardware and standard torque.
10. Coat housing-to-manifold circumferential juncture with B270-21 protectant.
11. Drain and flush hydraulic system per § 1.180.

CHAPTER 3

LIFE-LIMITED COMPONENTS

<i>Section</i>	<i>Title</i>	<i>Page</i>
3.100	Life-Limited Components	3.1
3.110	Time-in-Service Records	3.1
3.120	Fatigue Life-Limited Parts	3.1
3.200	Type Certificate Data Sheet (TCDS)	3.2
3.300	Airworthiness Limitations	3.3

Intentionally Blank

CHAPTER 3

LIFE-LIMITED COMPONENTS

3.100 Life-Limited Components3.110 Time-In-Service Records

It is the operator's responsibility to maintain a record of time in service for the airframe, engine, and life-limited components. An hourmeter activated by engine oil pressure is standard equipment on earlier R44 helicopters. Later helicopters are equipped with an hourmeter activated by a combination of oil pressure and up collective; the hourmeter will record time only when engine oil pressure exists and the collective is raised. Either hourmeter is an acceptable means of recording time in service (refer to § 1.007).

Calendar time in service for the airframe and engine begins on the date of the original RHC-issued Export (or Standard) Certificate of Airworthiness for the helicopter. For spares without a storage limit specified in § 1.160, calendar time in service begins on the date of the RHC-issued Airworthiness Approval Tag (Authorized Release Certificate) issued with the invoice.

If a component or an inspection is scheduled for hourly and calendar intervals, comply with whichever requirement comes first, then reset interval unless otherwise specified.

When installing a life-limited part or a part with an overhaul requirement, record in the helicopter maintenance record the installation date, part number, part name, serial number, helicopter total time, and time in service accumulated by part since new or since last overhaul, as applicable.

WARNING

Components with mandatory overhaul times or life limits whose time in service is not reliably documented cannot be considered airworthy and must be removed from service.

3.120 Fatigue Life-Limited Parts

The Airworthiness Limitations section lists the mandatory replacement schedule for fatigue life-limited parts.

If a part is fatigue life-limited or has a mandatory overhaul requirement and is interchanged between an R44 and an R66 helicopter, and if the part life-limit or overhaul requirement is different between an R44 and an R66 helicopter, the shorter life-limit or overhaul requirement must be used. If a part is fatigue life-limited or has a mandatory overhaul requirement, and the accumulated cycles and/or time-in-service are known but the helicopter type is unknown, the shorter life-limit or overhaul requirement must be used.

Listed items must be removed from the helicopter at the specified intervals and permanently retired from service by destroying or damaging each part so it cannot inadvertently be returned to service.

3.200 Type Certificate Data Sheet (TCDS)

| TCDS H11NM is available at FAA Dynamic Regulatory System website: <https://drs.faa.gov>.

3.300 Airworthiness Limitations

The Airworthiness Limitations Section is FAA approved and specifies inspections and other maintenance required under 14 CFR §§ 43.16 and 91.403, unless an alternative program has been FAA approved.

There are two lists for fatigue life-limited parts. The first list (this page) is applicable to all R44 and R44 II helicopters. The second list (following page) provides increased service lives which may be used for the two-seat R44 Cadet configuration (R44 serial numbers 30001 through 39999).

R44 and R44 II Fatigue Life-Limited Parts

<u>Part Number</u>	<u>Description</u>	<u>Maximum Service Life</u>
C023-1	Tailcone Assembly, Rev M & Prior	2000 Hours
C016-2 ⁴ , -5 ⁴ , & -7	Main Rotor Blade	2200 Hours or 12 years ¹
C020-1 & -2	Upper Frame	2200 Hours
C029-1, -2, & -3	Tail Rotor Blade	2200 Hours or 12 years ¹
C030-1	Tail Rotor Hub	2200 Hours
C044-1	Horizontal Stabilizer, Rev L & Prior	2200 Hours ²
C146-1 & -5	Gear Set, Main Gearbox	2200 Hours
C146-2	Pinion, Main Gearbox	2200 Hours
C154-1	Main Rotor Hub	2200 Hours ²
C158-1	Main Rotor Spindle	2200 Hours ²
C196-1	Tail Rotor Drive Shaft	2200 Hours
C263-1 & -2	Sump, Main Gearbox	2200 Hours
C264-1 & -2	Housing, Main Gearbox	2200 Hours
C545-1	Gear Set, Tail Gearbox	2200 Hours ²
C545-2	Pinion, Tail Gearbox	2200 Hours ²
C647-12	Bearing Set, C017-6 Swashplate	2200 Hours ²
D062-2	Tail Rotor Hub	2200 Hours
D079-1	Tail Rotor Guard	2200 Hours ²
G062-2	Tail Rotor Hub	2200 Hours ²
A756-6 ⁴	Cyclic Grip	4400 Hours
C023-1	Tailcone Assembly, Rev N & Subsequent	4400 Hours
C023-2, -3, -4, -14, & -15	Tailcone Assembly	4400 Hours
C044-1	Horizontal Stabilizer, Rev M & Subsequent	4400 Hours ²
C198-1 & -2	Lower Swashplate	4400 Hours
C251-1	Main Rotor Shaft	4400 Hours
C319-3 ⁴	Cyclic Torque Tube	4400 Hours
C320-1 ⁴	Cyclic Stick	4400 Hours
C337-1 ⁴	Jackshaft	4400 Hours
D196-1	Tail Rotor Drive Shaft	4400 Hours ²
F050-2	Horizontal Stabilizer	4400 Hours ³

¹ Whichever limit occurs first. Calendar time starts on date of original RHC-issued Airworthiness Approval.
² Maximum service life is 2000 hours if part is, or ever has been, installed on an R66 helicopter.
³ Maximum service life is 4000 hours if part is, or ever has been, installed on an R66 helicopter.
⁴ Obsolete due to FAA AD 2014-23-16.

3.300 Airworthiness Limitations (continued)

R44 Cadet Fatigue Life-Limited Parts

The following service lives may be used for parts installed on R44 helicopter serial numbers 30001 through 39999. The service lives from the first list (previous page) must be used if the part is, or ever has been, installed on any R44 helicopter other than serial numbers 30001 through 39999.

<u>Part Number</u>	<u>Description</u>	<u>Maximum Service Life</u>
C016-7	Main Rotor Blade, Rev AF & Subsequent	2400 Hours or 12 years ¹
C020-1 & -2	Upper Frame	2400 Hours
C029-3	Tail Rotor Blade	2400 Hours or 12 years ¹
C146-2	Pinion, Main Gearbox	2400 Hours
C146-5	Gear Set, Main Gearbox	2400 Hours
C154-1	Main Rotor Hub	2400 Hours
C158-1	Main Rotor Spindle	2400 Hours
C263-2	Sump, Main Gearbox	2400 Hours
C264-2	Housing, Main Gearbox	2400 Hours
C545-1	Gear Set, Tail Gearbox	2400 Hours
C545-2	Pinion, Tail Gearbox	2400 Hours
C647-12	Bearing Set, C017-6 Swashplate	2400 Hours
D079-1	Tail Rotor Guard	2400 Hours
G062-2	Tail Rotor Hub	2400 Hours
C023-1, -14, & -15	Tailcone Assembly, Rev AQ & Subsequent	4800 Hours
C044-1	Horizontal Stabilizer, Rev P & Subsequent	4800 Hours
D196-1	Tail Rotor Drive Shaft	4800 Hours
F050-2	Horizontal Stabilizer	4800 Hours

¹ Whichever limit occurs first. Calendar time starts on date of original RHC-issued Airworthiness Approval.

Approved By: Maureen Moreland Digitally signed by Maureen Moreland
 Date: 2023.10.24 16:08:46 -07'00' Date: 24 Oct 2023
 For Manager, Federal Aviation Administration
 West Certification Branch, AIR-770

FAA Approved: This and the previous page constitute the Airworthiness Limitations Section in its entirety, are considered segregated from the rest of the document, and set forth the FAA-approved mandatory replacement times for fatigue life-limited parts.

CHAPTER 4

AIRFRAME

<u>Section</u>	<u>Title</u>	<u>Page</u>
4.000	Description	4.1
4.100	Cabin Assembly	4.1
4.110	Repair	4.1
4.120	Windshield Assembly	4.2
4.130	Door Removal and Installation	4.2
4.140	Fairing, Cowling and Inspection Panels	4.6
4.141	Engine Cowling	4.6
4.142	Mast Fairing	4.6
4.143	Upper Cowling	4.6
4.144	Cabin Inspection Panels	4.7
4.200	Steel Tube Frame Assemblies	4.8
4.210	Lower Frame Assembly, LH	4.8
4.211	Frame Removal	4.8
4.212	Frame Installation	4.12
4.220	Lower Frame Assembly, RH	4.13
4.221	Frame Removal	4.13
4.222	Frame Installation	4.13
4.230	Upper Frame Assembly	4.14
4.231	Frame Removal	4.14
4.232	Frame Installation	4.15
4.240	Strut Assembly Removal and Installation	4.15
4.300	Tailcone Assembly	4.17
4.310	Inspection and Repair	4.19
4.400	Tail Rotor Guard Assembly	4.21
4.500	F050-2 Horizontal Stabilizer Assembly	4.23
4.600	Empennage Assembly	4.25
4.610	Upper Vertical Stabilizer Assembly	4.27
4.620	Lower Vertical Stabilizer Assembly	4.28
4.630	F044-1 Vertical Stabilizers Mount Assembly	4.29
4.640	C044-1 Horizontal Stabilizer	4.30
4.700	C050-2 Float Stabilizer Assembly (Pop-Out or Fixed Floats)	4.32
4.800	Tail Skid	4.32

Intentionally Blank

CHAPTER 4

AIRFRAME

4.000 Description

The R44 I & R44 II are both a four-place (R44 Cadet version is two-place, refer to Chapter 36), single-main-rotor, single-engine helicopter constructed primarily of metal and equipped with skid-type landing gear.

Primary structure is welded steel tubing and riveted aluminum. The tailcone is a monocoque structure in which aluminum skins carry most of the primary loads. Fiberglass and thermoset plastics are used in the secondary structure of the cabin, engine cooling system, and in various other ducts and fairings.

Cabin doors are removable. Four hinged cowl doors on right side provide access to main rotor gearbox, drive system and engine. A hinged cowl door on left side provides access to engine oil filler, dip stick, and battery (if installed here). For additional access to controls and other components, there are removable panels between seat cushions and seat backs, on each side and aft of engine compartment, under cabin and forward of tailcone.

The instrument console hinges up and aft for access to wiring and instrument connections and battery (if installed here). Small removable plug buttons are located on tailcone for internal inspection.

One stainless steel vertical firewall is forward of the engine and a stainless steel horizontal firewall is above the engine.

4.100 Cabin Assembly

The cabin assembly is a non-field-replaceable assembly.

4.110 Repair

1. Vertical firewall repairs may be accomplished in accordance with U.S. FAA Advisory Circular 43.13-1B paragraph 4-59. Firewall material is 0.016-inch thick, type 301, one-quarter hard corrosion-resistant (CRES) steel.
2. Keel panel replacement must be performed at the factory in a jig. Keel panel repairs may be accomplished in accordance with U.S. FAA Advisory Circular 43.13-1B. Keel panel material is 0.025-inch thick, 2024-T3 clad aluminum sheet.
3. To preserve crashworthiness, repairs to seat structure are limited to replacement of damaged components only.

4.120 Windshield Assembly

| This section has been moved to Chapter 27 Doors and Windows.

4.130 Door Removal and Installation

| This section has been moved to Chapter 27 Doors and Windows.

Intentionally Blank

Intentionally Blank

Intentionally Blank

4.140 Fairing, Cowling, and Inspection Panels

4.141 Engine Cowling

Engine cowling includes left-hand and right-hand cowling assemblies, belly cowling assembly, and the aft cowling assembly.

The lower edge of both engine cowling assemblies are supported by removable channels. The air intake hose is attached to right engine side panel assembly, which may be removed or connected through door in panel. Lower left slat in aft cowling assembly may be removed for access to clean out anything that may have fallen through slats.

4.142 Mast Fairing

CAUTION

Mast fairing must be installed for flight.

The C261 mast fairing upper rib is mounted to main rotor gearbox at swashplate tube assembly. Lower rib is clamped to main rotor gearbox mast assembly.

The pitot tube is mounted on lower front of mast fairing.

The fuel tank vents are installed through grommets in lower rib and attach to middle rib of mast fairing. The C665-2 guide assembly for C121-5 push-pull tube is mounted to center rib. It should be adjusted to minimize preload on push-pull tube.

4.143 Upper Cowling

Cowling above horizontal firewall includes D042 doors behind and below auxiliary tank, C347 panels around mast tube, and C706-1 tailcone cowling.

CAUTION

All cowlings must be installed for flight.

4.144 Cabin Inspection Panels

CAUTION

Inspection panels must be installed for flight. All panels may be left off for run-up. All must be installed for flight.

The cabin inspection panels include the following:

1. C794-1 forward belly panel and C794-3 aft belly panel assembly.
2. C465-1 and C465-2 aft seat back panels.
3. C474-1 panel between the aft seat backs and C474-2 panel between the aft seats.
4. C463-1 cover under the C464-1 tray.
5. C445-1 and C445-3 covers between the forward seats and C444-1 cyclic box cover.
6. C461-1 collective cross tube cover behind the left forward seat.

4.200 STEEL TUBE FRAME ASSEMBLIES

WARNING

All welded steel tube frames used in the R44 are stress relieved. No weld repairs are permissible outside Robinson Helicopter Company.

The following steel tube frames are required on the R44:

- C020-1 Upper Frame Assembly
- C046-1 Lower Frame Assembly, L.H.
- C046-2 Lower Frame Assembly, R.H.
- C046-3 Strut Assembly
- C237-1 Frame Assembly

4.210 Lower Frame Assembly, L.H.

4.211 Frame Removal

- a) Remove all cowling.
- b) Remove main rotor gearbox, including both fuel tanks, per Section 7.110.
- c) Remove powerplant, including tailcone and clutch assembly, per Section 6.110.
- d) Remove battery and battery box.
- e) Remove left aft seatback panel.
- f) Disconnect the three forward mounting points (Figure 4-2A, Details D, E, and F) and the aft mounting point (Figure 4-2B, Detail H).
- g) Disconnect the left aft NAS1307 landing gear mounting bolt.
- h) Remove the NAS6604-2 bolt and the C722-2 cap screw connecting the upper frame to the lower left frame assembly (Figure 4-2, Details A & B).

NAS6604-2 BOLT
 AN960-416L WASHER (2 REQ'D.)
 NAS679A4 NUT
 (2 PL'CS.)

A

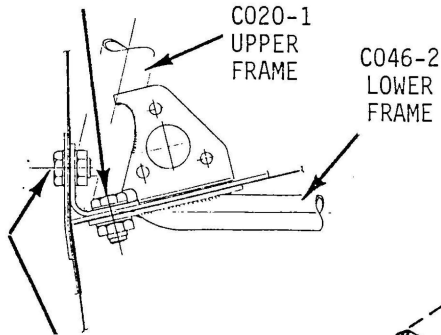

NAS6604-2 BOLT
 AN960-416L WASHER (4 REQ'D.)
 NAS679A4 NUT (2 REQ'D.)

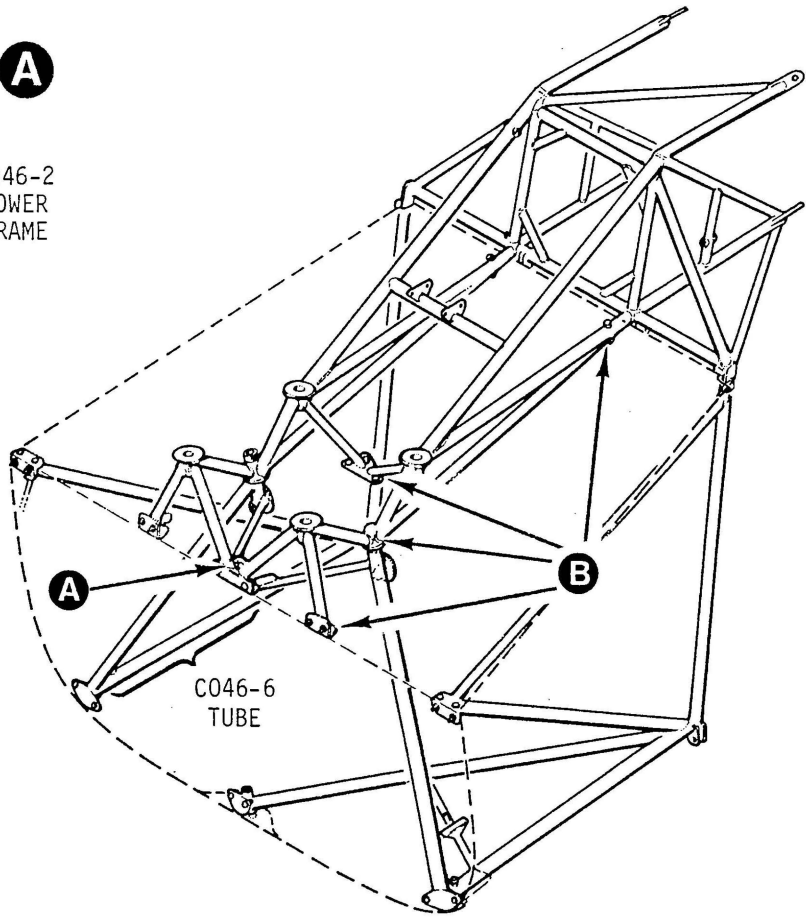

NAS6604-2 BOLT
 AN960-416L WASHER (2 REQ'D.)
 NAS679A4 NUT
 (3 PL'CS.)

NAS6605-21 BOLT
 AN960-516L WASHER (2 REQ'D.)
 NAS679A5 NUT
 (2 PL'CS.)

C020-1
 UPPER
 FRAME

C722-2 SCREW
 MS20002C10 WASHER

NAS6605-4 BOLT
 AN960-516L WASHER (2 REQ'D)
 NAS679A5 NUT
 (4 PL'CS.)

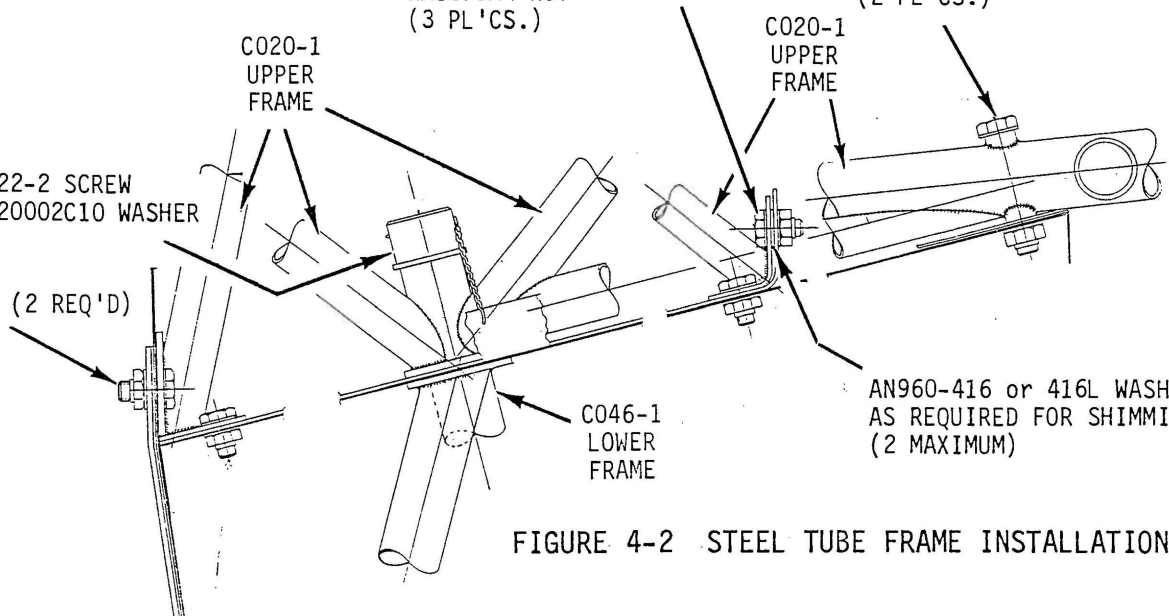

FIGURE 4-2 STEEL TUBE FRAME INSTALLATION

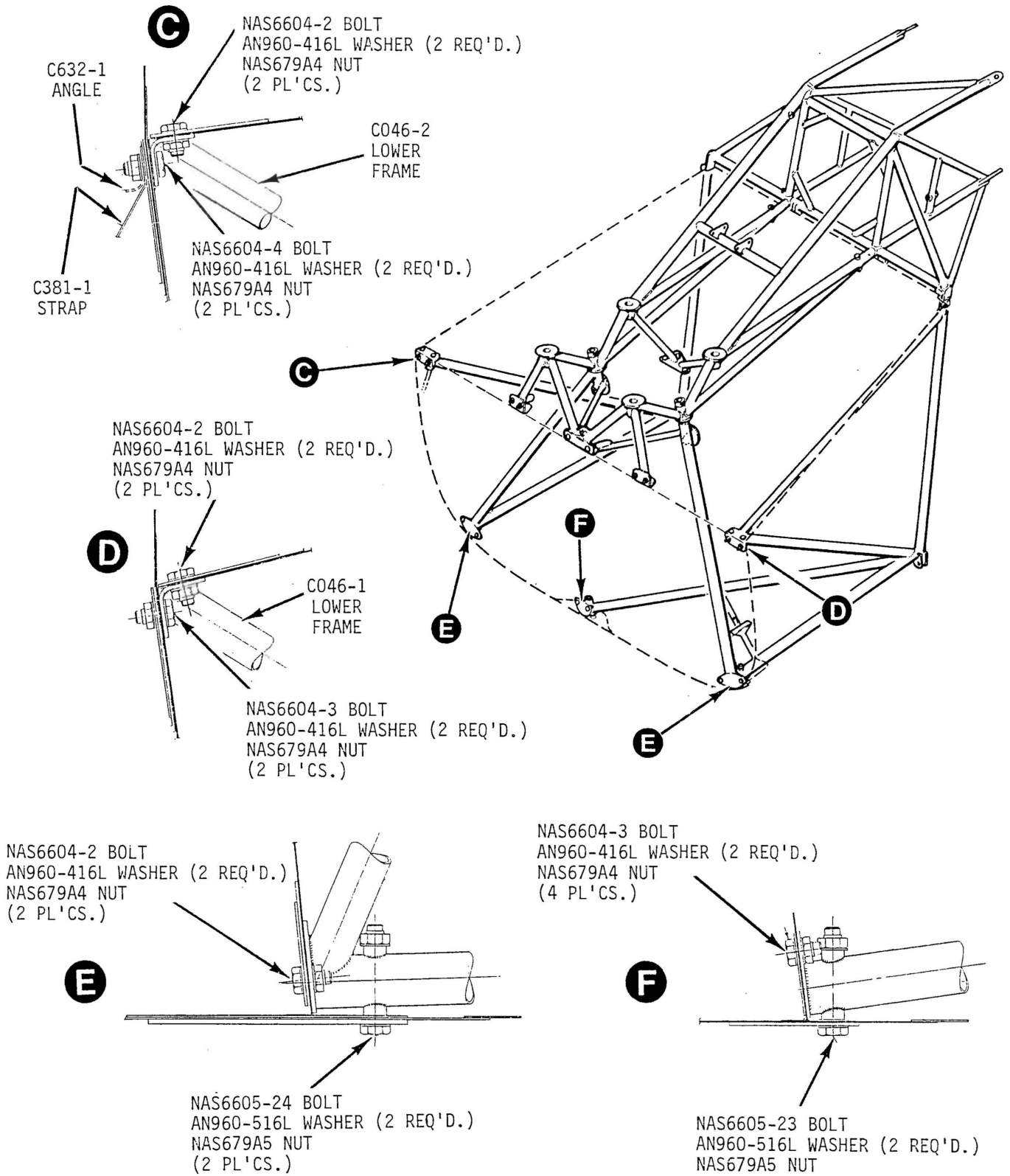

FIGURE 4-2A STEEL TUBE FRAME INSTALLATION

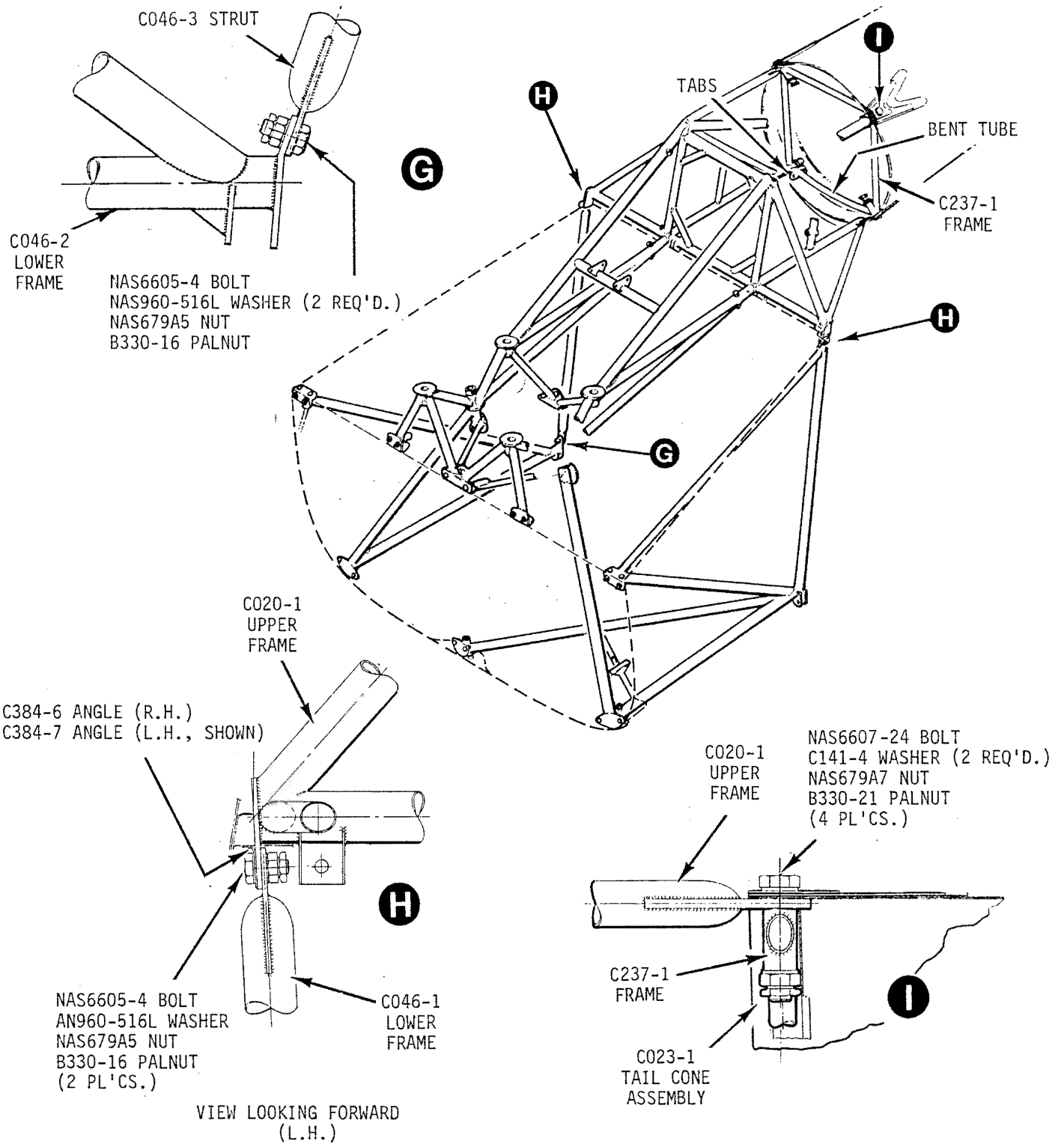

FIGURE 4-2B STEEL TUBE FRAME AND TAIL CONE INSTALLATION

4.211 Frame Removal (cont'd)

- i) Remove the left frame assembly.
- j) Remove the C014-7 landing gear support and D310-5 cowling bracket from the left frame assembly.

4.212 Frame Installation

- a) Install the C014-7 landing gear support and D310-5 cowling bracket per Figure 5-1, Detail B. Torque per Section 1.320.
- b) Position frame for installation. Install all hardware per Figure 4-2, Detail B, Figure 4-2A, Details D,E, and F, and Figure 4-2B, Detail H. Install all hardware before torquing.
- c) Torque all NAS6600 bolts per Section 1.320. Torque the C722-2 Cap Screw per Section 1.330 and safety wire to the C385-1 firewall doubler with 0.041 inch diameter wire.
- d) Install NAS6607 landing gear mounting bolt per Figure 5-1, Detail B, and torque per Section 1.320.
- e) Install powerplant per Section 6.120.
- f) Install tailcone per Section 4.312.
- g) Install main rotor gearbox per Section 7.120.
- h) Install clutch assembly per Section 7.220.
- i) Install battery box and battery.
- j) Verify all mounting hardware is torqued and install left aft seat back panel.
- k) Install all cowling.

4.220 Lower Frame Assembly, RH

4.221 Frame Removal

1. Remove all cowling.
2. Remove main rotor gearbox, including both fuel tanks, per Section 7.110.
3. Remove powerplant, including tailcone, C046-3 strut, and clutch assembly, per Section 6.110.
4. Remove right rear seatback.
5. Disconnect the aft NAS6607 landing gear mounting bolt from the right landing gear support.
6. Disconnect the two forward mounting points (Figure 4-2A, Details C and E).
7. Remove the NAS6604-2 bolt and the C722-2 cap screw connecting the upper frame to the lower right frame assembly (Figure 4-2, Details A and B).
8. Remove the right frame assembly.
9. Remove the C014-7 landing gear support and the D310-6 bracket from the right frame assembly.

4.222 Frame Installation

1. Install the C014-7 landing gear support and D310-6 bracket per Figure 5-1. Torque per Section 1.320.
2. Position frame for installation. Install all hardware per Figure 4-2, Details A and B and Figure 4-2A, Details C and E. Install all hardware before torquing.
3. Torque all NAS6600 bolts per Section 1.320. Torque the C722-2 cap screw per Section 1.330 and safety wire to the C385-1 firewall doubler with 0.041 inch diameter safety wire.
4. Install NAS6607 landing gear mounting bolt per Figure 5-1 and torque per Section 1.320.
5. Install powerplant per Section 6.120.
6. Install tailcone per Section 4.300.
7. Install main rotor gearbox per Section 7.120.
8. Install clutch assembly per Section 7.200.
9. Verify all mounting hardware is torqued and install right aft seat back panel. Install all cowling.

4.230 Upper Frame Assembly

4.231 Frame Removal

Before the upper frame is disconnected and removed, the powerplant must be either removed or supported.

CAUTION

Extensive damage to the firewall and lower frame assemblies will occur if powerplant is not supported or if support is dislodged.

1. Remove all cowling.
2. Remove clutch assembly per Section 7.200.
3. Remove main rotor gearbox, including both fuel tanks, per Section 7.110.
4. Remove tailcone per Section 4.300.
5. Support powerplant or remove per Section 6.110.
6. Remove the right and left aft seat backs and panel between seatbacks.
7. Remove C316-1 upper bellcrank per Section 8.531 and remove the C121-15 push-pull tube.
8. Remove the C723 bulkhead assemblies at the aft end of the horizontal firewall.
9. Remove the NAS6605-4 bolts at the aft outboard corners of the horizontal firewall (Figure 4-2B, Detail H).
10. Remove all NAS6600 bolts and the C722-2 cap screws shown in Figure 4-2, Details A and B.
11. Remove upper frame.
12. Remove C329-1 bearing block assembly and A331-4 bellcrank assembly from upper frame.

4.232 Frame Installation

1. Clean upper frame and mounting points of all sealant, grease and oil. Install C329-1 bearing block assembly using AN509-8R11 screws, AN960-8L washers, and NAS1291-08 nuts, 3 places. Install A331-4 bellcrank assembly per Section 8.542.
2. Position upper frame for installation. Install all hardware per Figure 4-2, Details A and B and Figure 4-2B, Detail H. Install all hardware before torquing.
3. Torque all NAS6600 bolts per Section 1.320. Torque the C722-2 cap screws per Section 1.330 and safety wire to the C385-1 firewall doubler with 0.041 inch diameter wire.
4. Seal firewalls using B270-1 sealant to prevent fuel seepage.
5. Install the C723 bulkhead assemblies.
6. Install the C316-1 upper bellcrank per Section 8.532 and install the C121-15 push-pull tube.
7. Install powerplant, if removed, per Section 6.120.
8. Install tailcone per Section 4.300.
9. Install main rotor gearbox per Section 7.120.
10. Install clutch assembly per Section 7.200.
11. Verify all mounting hardware is torqued and install aft seat back and center panels.
12. Install all cowling.

4.240 Strut Assembly Removal and Installation

A. Removal

1. Remove right engine side panel and aft engine cowling.
2. Support engine from below to reduce the load on the lower frames.
3. Remove upper and lower mounting bolts and remove strut.

B. Installation

1. Install strut and hardware as shown in Figure 4-2B, Details G and H.
2. Torque bolts per Section 1.320.
3. Remove engine supports.
4. Install cowling.

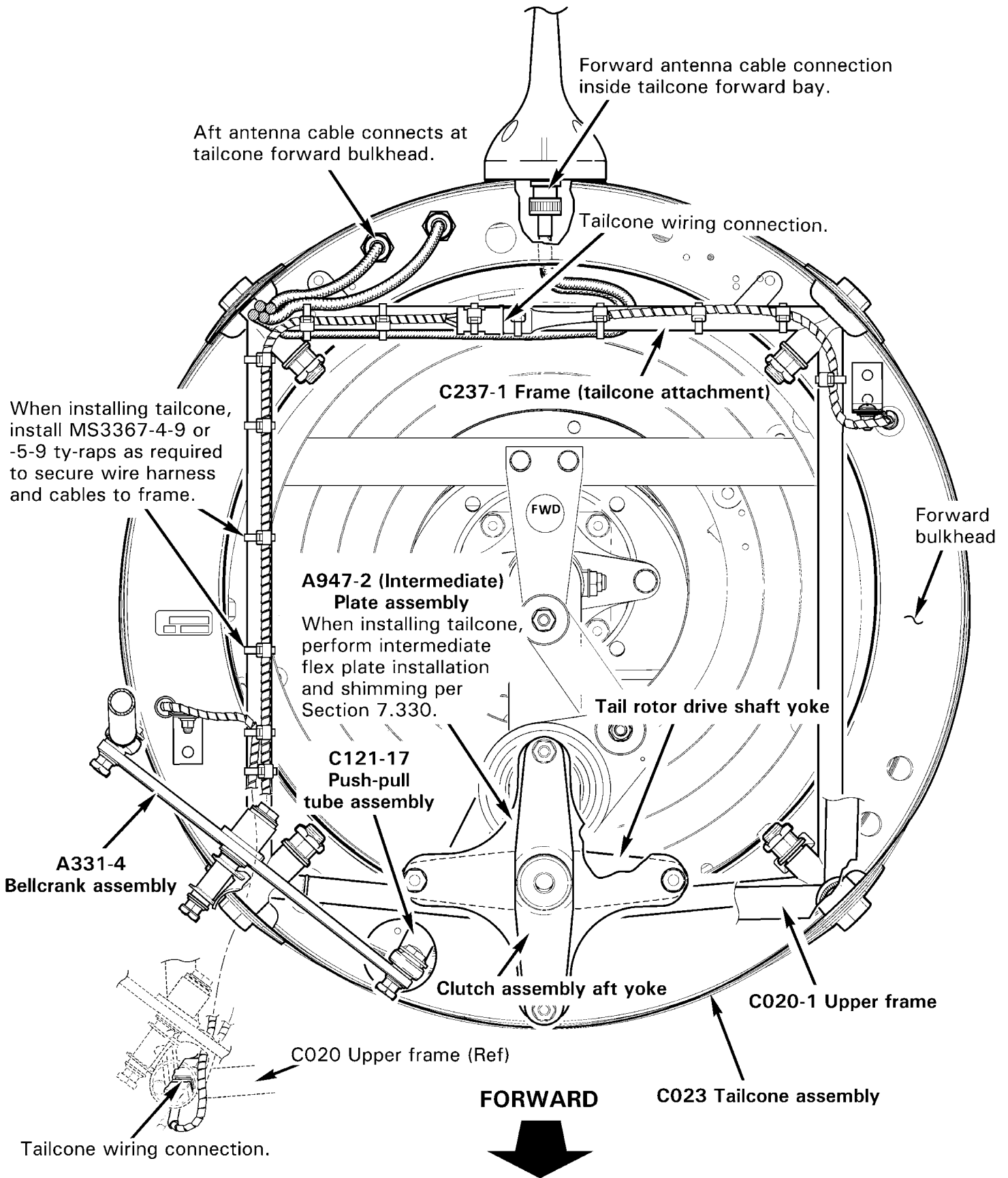

FIGURE 4-3 TAILCONE ASSEMBLY

4.300 Tailcone Assembly

NOTE

Tailcones with F955-1 bracket may not be installed on R44 I helicopters if C169-1 exhaust muffler assembly (smaller, 6.0-inch diameter shroud assembly) is installed.

CAUTION

If tailcone has an F955-1 bracket then F050-2 horizontal stabilizer must be installed.

C044-1 horizontal stabilizer may not be installed on a tailcone that has an F955-1 bracket.

F044-1 vertical stabilizers mount assembly may only be installed on a tailcone that has an F955-1 bracket.

A. Removal

1. Pull associated circuit breakers for lights and antennas installed on tailcone, and C706-1 tailcone fairing.
2. Remove tailcone fairing and D040-1 aft cowling assemblies.
3. Refer to Figure 4-3. Cut and discard ty-raps as required and disconnect tailcone wiring at connectors. Disconnect two antenna cables inside tailcone forward bay, and cables at forward bulkhead, as required.
4. Remove hardware securing tail rotor drive shaft assembly forward yoke to A947-2 (intermediate) plate assembly. Support drive shaft using a foam block or equivalent, while drive shaft is disconnected from drive train.
5. Remove hardware securing C121-17 push-pull tube to A331-4 bellcrank assembly.
6. Remove hardware securing C023 tailcone assembly to frames and remove tailcone.
7. Cut and discard ty-raps as required and remove C237-1 tailcone-attachment frame, as required.

B. Installation

1. Refer to Figure 4-3. Install C237-1 tailcone-attachment frame, if not previously accomplished. Verify correct damper assembly orientation per Figure 7-11B.
2. Position C023 tailcone assembly on C020-1 upper frame assembly; do not pinch wiring between tailcone forward bulkhead and frames. Install hardware securing tailcone to frames, standard torque bolts per § 23-32, torque stripe per Figure 2-1.
3. Install hardware securing C121-17 push-pull tube to A331-4 bellcrank assembly. Standard torque bolt per § 23-32 and torque stripe per Figure 2-1.
4. Inspect flex plate per Figure 2-5. Perform intermediate flex plate installation and shimming per § 7.330.
5. Perform tail rotor drive shaft runout per § 7.340.

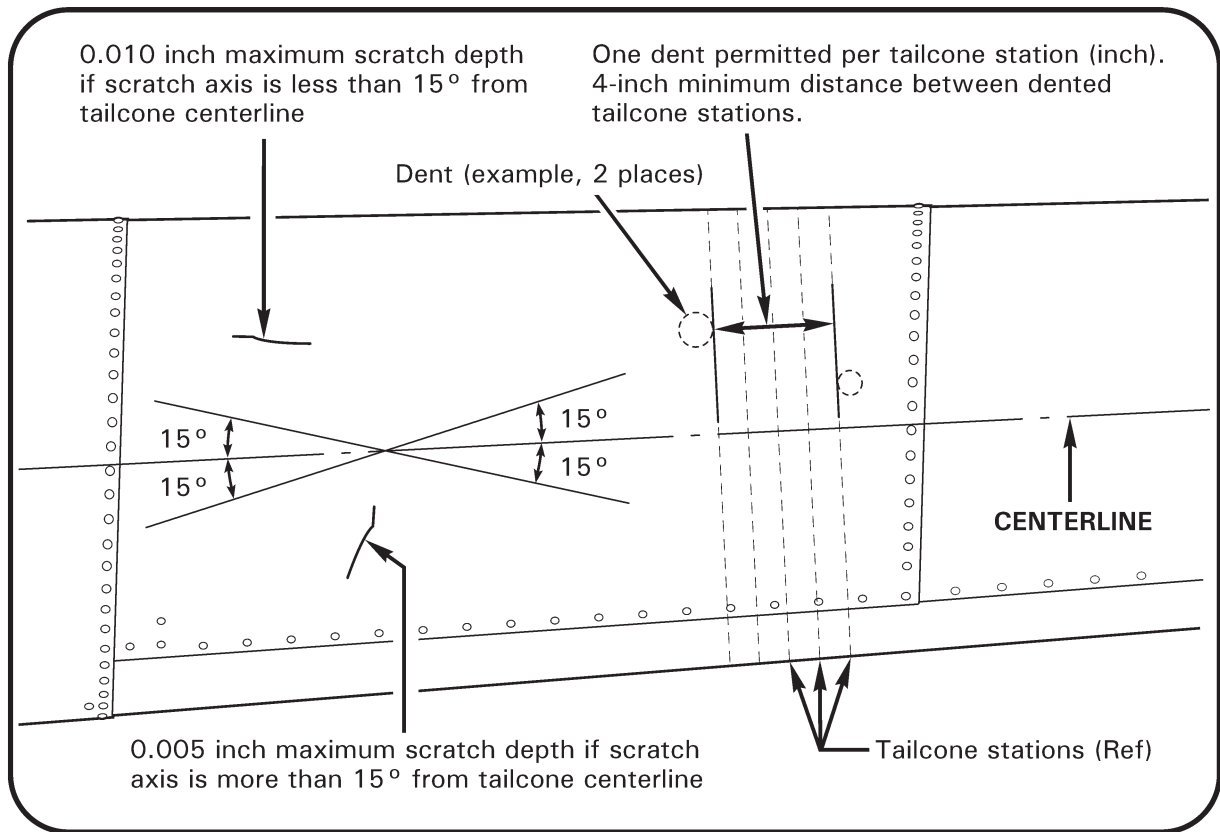
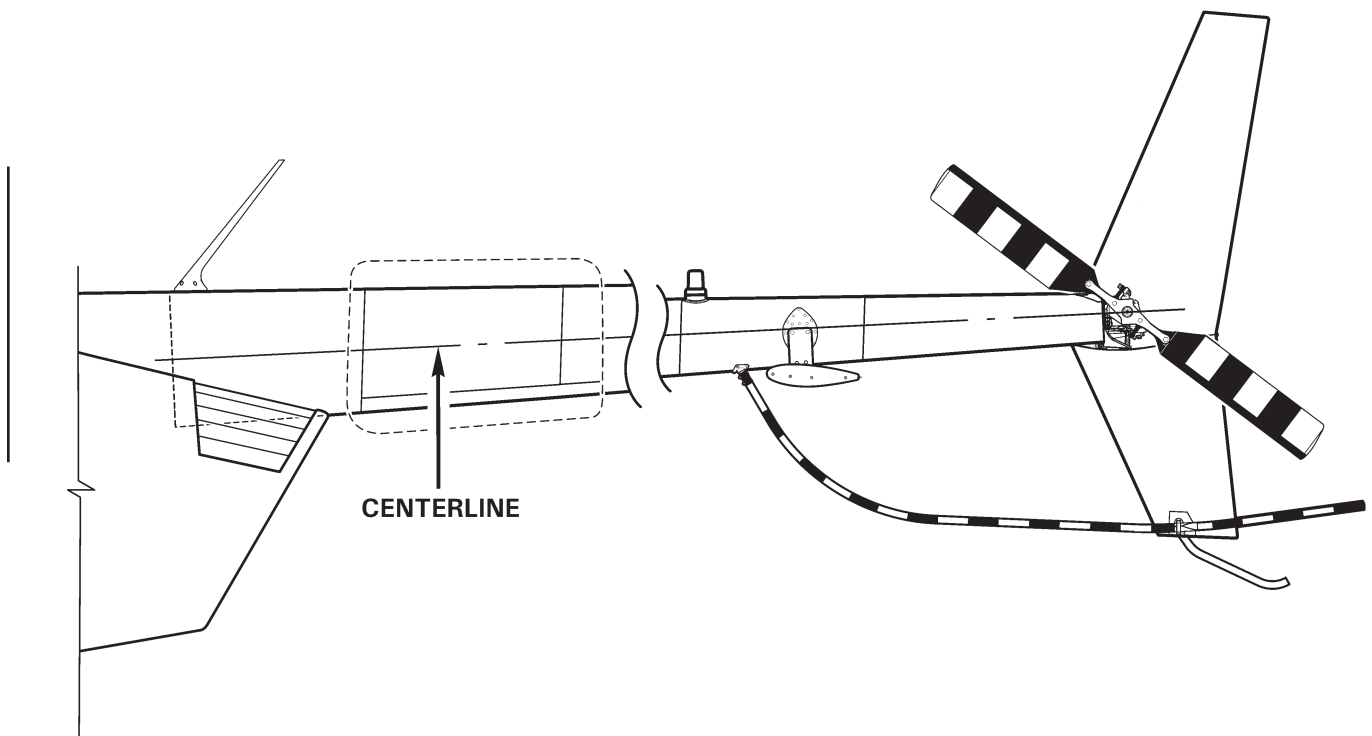

FIGURE 4-4 TAILCONE INSPECTION AND REPAIR

4.300 Tailcone Assembly (continued)

B. Installation (continued)

6. Connect tailcone wiring at connectors, connect two antenna cables inside tailcone forward bay, and connect antenna cables at forward bulkhead, as required. Individually test and verify correct function of tail position light, strobe, and TR chip light circuits.
7. Install MS3367-4-9 or -5-9 ty-raps as required to secure wire harness and cables to frame. Cinch ty-raps until snug without over-tightening, trim tips flush with heads.
8. Install C706-1 tailcone fairing and D040-1 aft cowling assemblies.

4.310 Inspection and Repair

Repairs are limited to blending out scratches within limits and refinishing skins. If allowable damage is exceeded, replace tailcone, or submit tailcone to RHC for repair.

A. Scratches

1. Refer to Figure 4-4. Verify damage does not exceed the following limits:
 - a. 0.005 inch maximum scratch depth if scratch axis is more than 15° from tailcone centerline.
 - b. 0.010 inch maximum scratch depth if scratch axis is less than 15° from tailcone centerline.
2. If damage exceeds limits, return tailcone assembly to RHC for repair. If damage is within limits, blend out scratches with a 0.10 inch minimum blend radius. Refinish skins using approved materials per § 23-70.

B. Dents

NOTE

0.125 inch minimum radius can be verified with using a 0.250 inch diameter bearing ball: Place bearing ball within dent and back light with lamp; if light is visible between skin & ball (i.e. ball not contacting dent bottom) then dent radius is less than 0.125 inch.

1. Refer to Figure 4-4. Smooth, round bottom dents with 0.125 inch minimum radius without sharp nicks or cracks are acceptable when damage does not exceed the following limits:
 - a. 0.030 inch maximum dent depth.
 - b. 1.250 inches maximum dent diameter.
 - c. One dent permitted per tailcone station (inch).
 - d. 4.000 inches minimum distance between dented tailcone stations.
2. If damage exceeds limits, replace tailcone or return to RHC for repair.

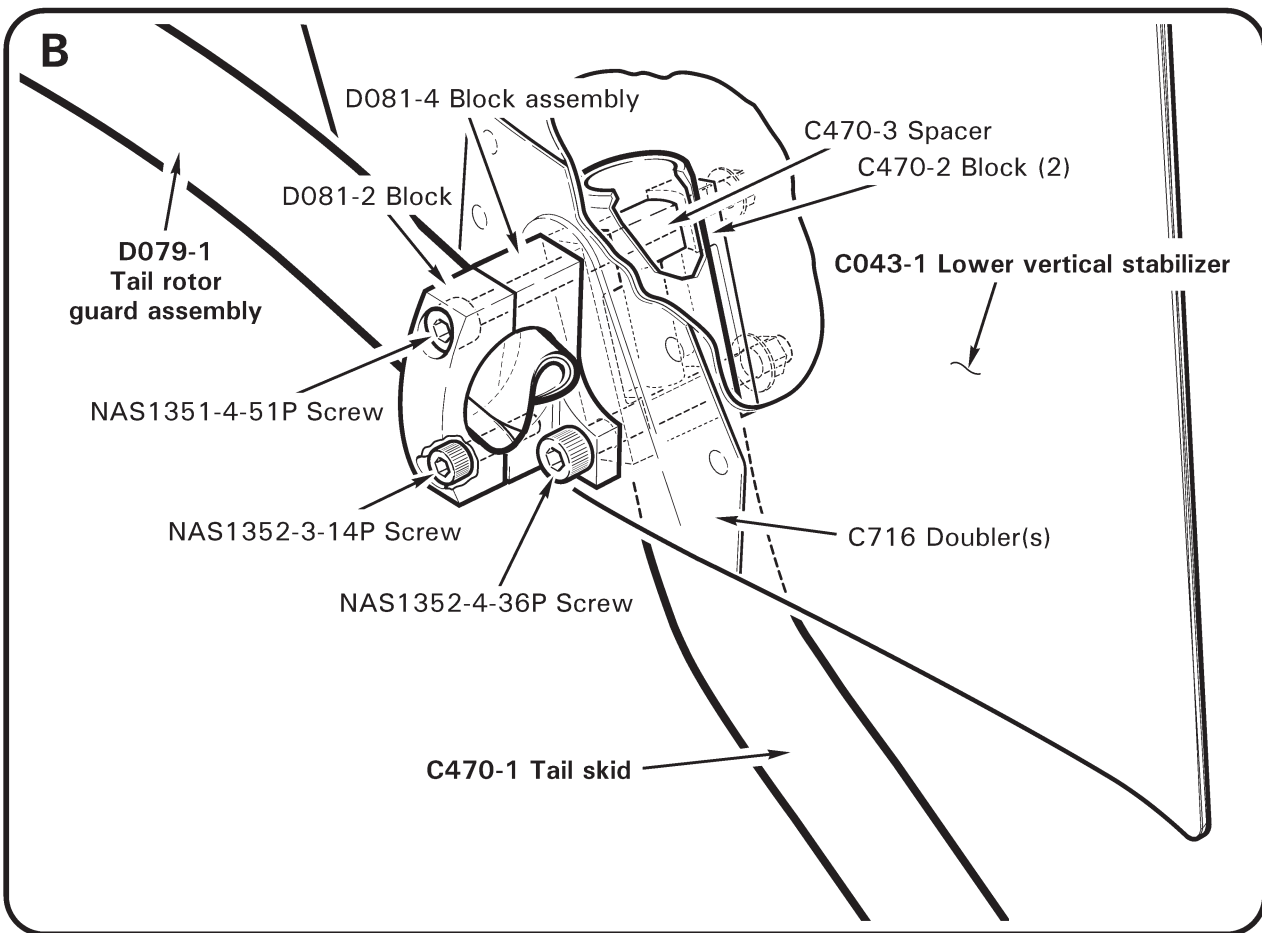
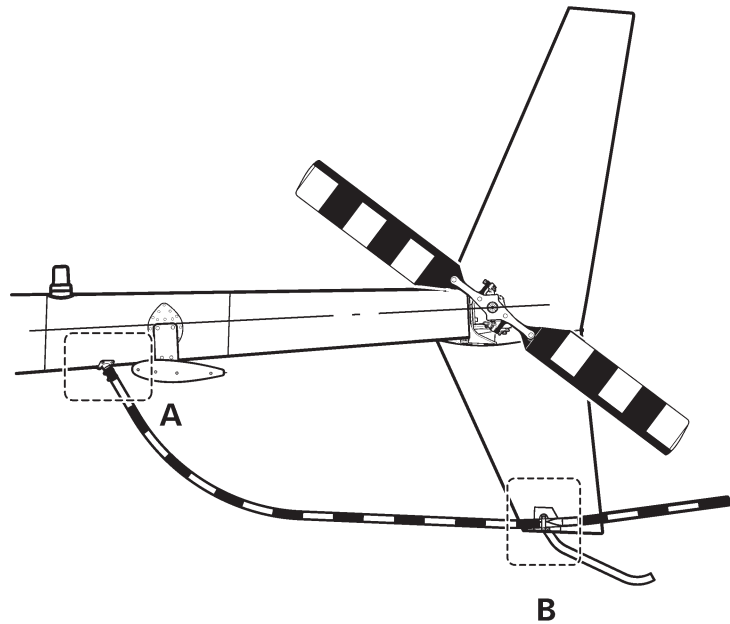
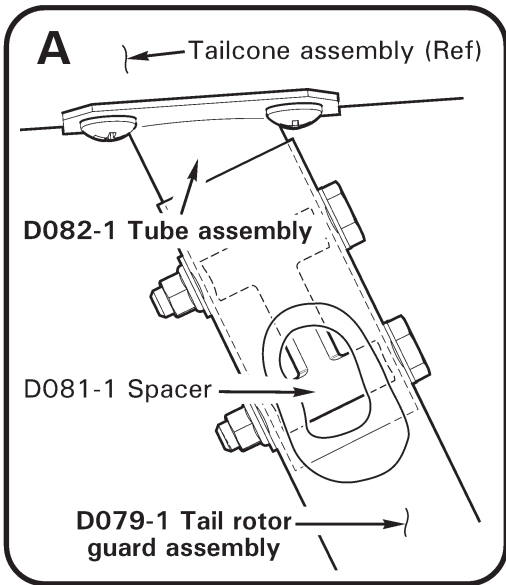

FIGURE 4-5 TAIL ROTOR GUARD ASSEMBLY
(C050-2 float stabilizer assembly not shown)

4.400 Tail Rotor Guard Assembly

A. Removal

1. Refer to Figure 4-5. Loosen two (forward) fasteners securing D081-2 block and D079-1 tail rotor guard assembly to C043-1 lower vertical stabilizer.
2. Remove hardware securing tail rotor guard to D082-1 tube assembly. Slide guard off of tube, then forward through blocks. Remove D081-1 spacer from tube.

B. Installation

1. Refer to Figure 4-5. Loosen two (forward) fasteners securing D081-2 block to C043-1 lower vertical stabilizer, if not previously accomplished. Insert D079-1 tail rotor guard assembly aft through blocks.
2. Install D081-1 spacer inside D082-1 tube assembly and align holes.
3. Lightly coat mating surfaces of tube and tail rotor guard, and retaining hardware bolt shanks, with § 23-70 approved primer. While wet with primer, slide tail rotor guard onto tube and install hardware ensuring bolts engage holes in spacer. Standard torque bolts per § 23-32, and torque stripe per Figure 2-1. Seal around end of tail rotor guard with primer after installation.
4. Verify D081 blocks clamp bonded sleeve on guard. For proper tail rotor guard-to-stabilizer clamping, first standard torque (forward, top) NAS1351-4-51P or -53P screw and associated hardware per § 23-32, then special torque (forward, bottom) NAS1352-3-14P screw and associated hardware per § 23-33. Torque stripe fasteners per Figure 2-1.

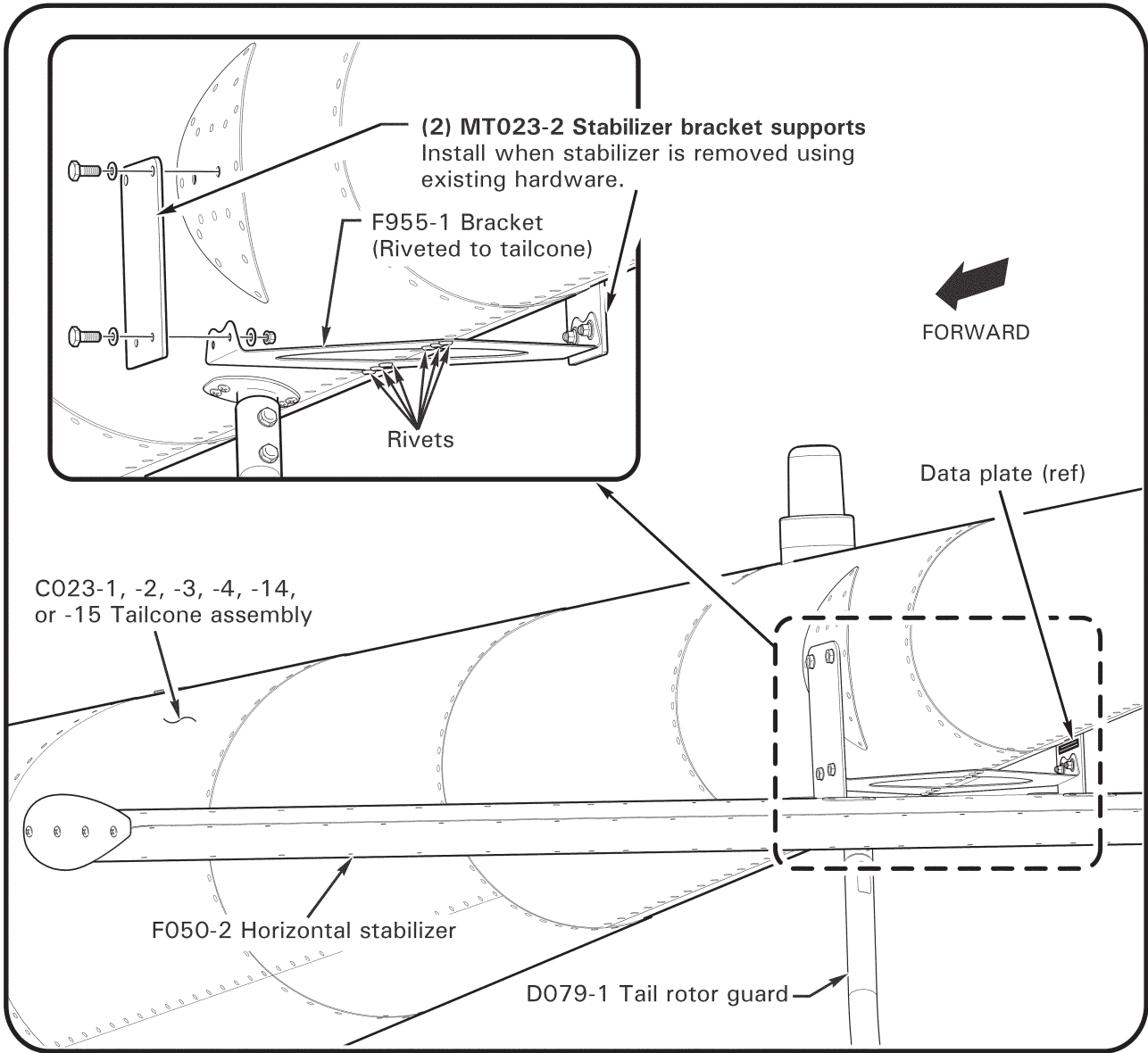

FIGURE 4-6 F050-2 HORIZONTAL STABILIZER ASSEMBLY

4.500 F050-2 Horizontal Stabilizer Assembly

NOTE

Tailcones with F955-1 bracket may not be installed on R44 I helicopters if C169-1 exhaust muffler assembly (smaller, 6.0-inch diameter shroud assembly) is installed.

CAUTION

If tailcone has an F955-1 bracket then F050-2 horizontal stabilizer must be installed.

CAUTION

Support F050-2 horizontal stabilizer assembly during removal or installation when upper bolts are removed. F955-1 bracket is riveted to bottom of tailcone assembly.

A. Removal

1. Refer to Figure 4-6. Remove hardware securing F050-2 horizontal stabilizer assembly to F955-1 bracket.
2. Support the stabilizer, remove hardware securing stabilizer to tailcone assembly and remove stabilizer.
3. As required, install MT023-1 stabilizer bracket supports using removed hardware (recommended when stabilizer is removed).

B. Installation

1. If installed, remove hardware securing MT023-2 stabilizer bracket supports to F955-1 bracket & tailcone assembly and remove supports.
2. Support the F050-2 horizontal stabilizer assembly, install hardware securing stabilizer to tailcone and bracket. Special torque bolts per § 23-33 and torque stripe per Figure 2-1.

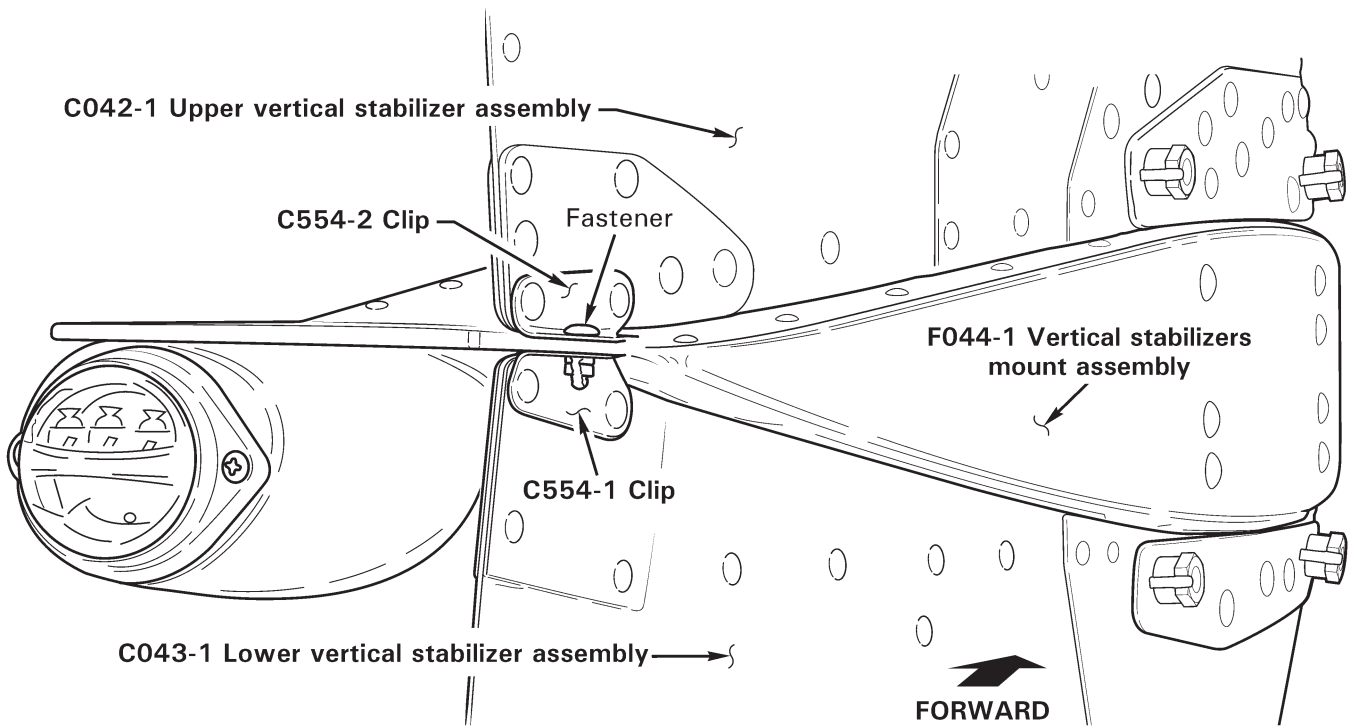
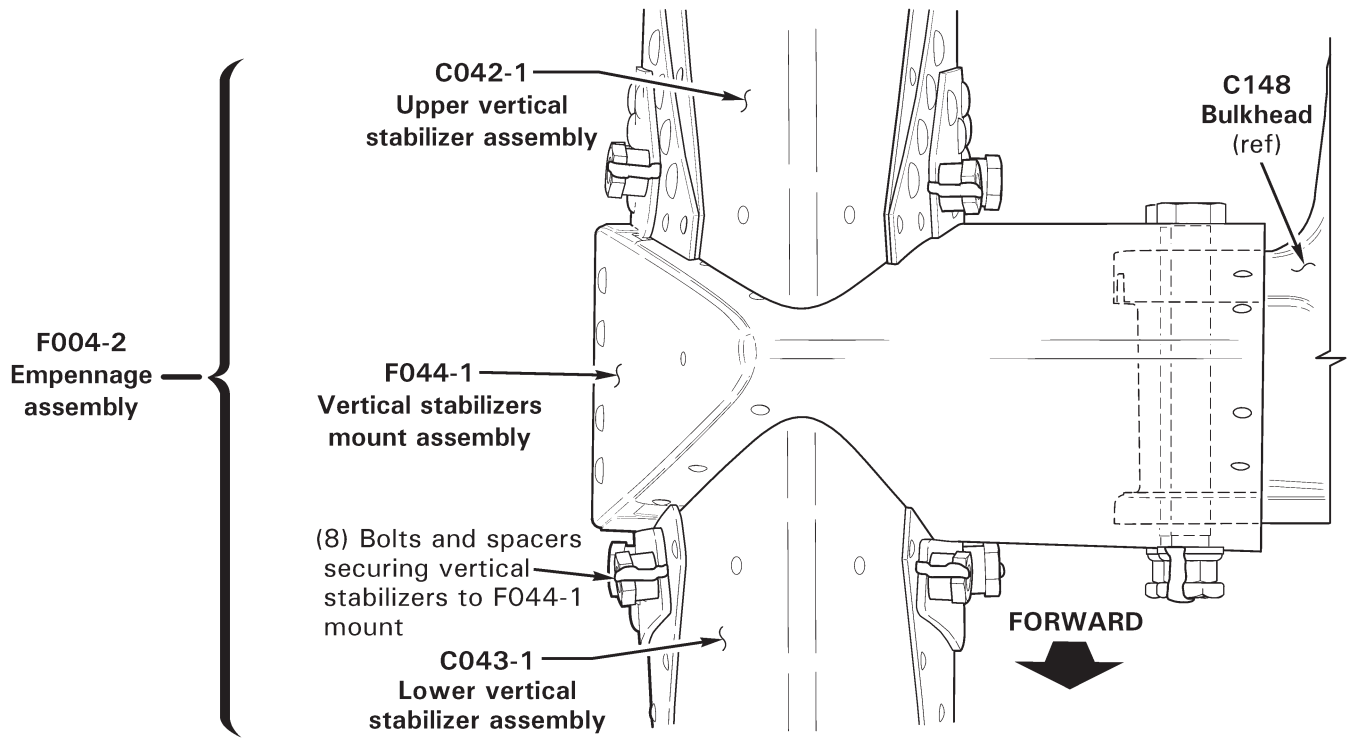

FIGURE 4-7 F004-2 EMPENNAGE ASSEMBLY

4.600 Empennage Assembly

CAUTION

If tailcone has an F955-1 bracket then F050-2 horizontal stabilizer must be installed.

C044-1 horizontal stabilizer may not be installed on a tailcone that has an F955-1 bracket.

F044-1 vertical stabilizers mount assembly may only be installed on a tailcone that has an F955-1 bracket.

A. Removal

1. Remove tail rotor guard per § 4.400.
2. Remove hardware securing forward clamp, on position light & TGB chip detector wires, to empennage. Cut and discard ty-raps securing position light wire. Disconnect position light wire at connectors.
3. Refer to Figure 4-7 or 4-7A. Support the empennage assembly, remove hardware securing empennage to C148 bulkhead, and remove empennage.

B. Installation

1. Refer to Figure 4-7 or 4-7A. Position empennage assembly on C148 bulkhead.
 - a. **If D301 (empennage ballast; ref. § 18-32) weights will not be installed:** Install (2) NAS6606-47 bolts & associated hardware securing empennage to C148 bulkhead. Use (1) or (2) NAS1149F0663P washers under nut as required to meet § 23-30 Part E.5. Standard torque bolts and palnuts per § 23-32 and torque stripe per Figure 2-1.
 - b. **If D301 (empennage ballast; ref. § 18-32) weights will be installed:** Install (2) NAS6606-78 bolts & associated hardware securing empennage to C148 bulkhead. Use (1) or (2) NAS1149F0663P washers under nut as required to meet § 23-30 Part E.5; 1–4 threads may be exposed beyond primary nut. Standard torque bolts and palnuts per § 23-32 and torque stripe per Figure 2-1.
2. Connect position light wire connectors. Install forward clamp on position light & TGB chip detector wires and secure to empennage with hardware. Install ty-raps as required to secure wires and connectors together. Cinch ty-raps until snug without over-tightening, and trim tips flush with heads.
3. Test and verify correct function of position and TR chip light circuits.
4. Install tail rotor guard per § 4.400.

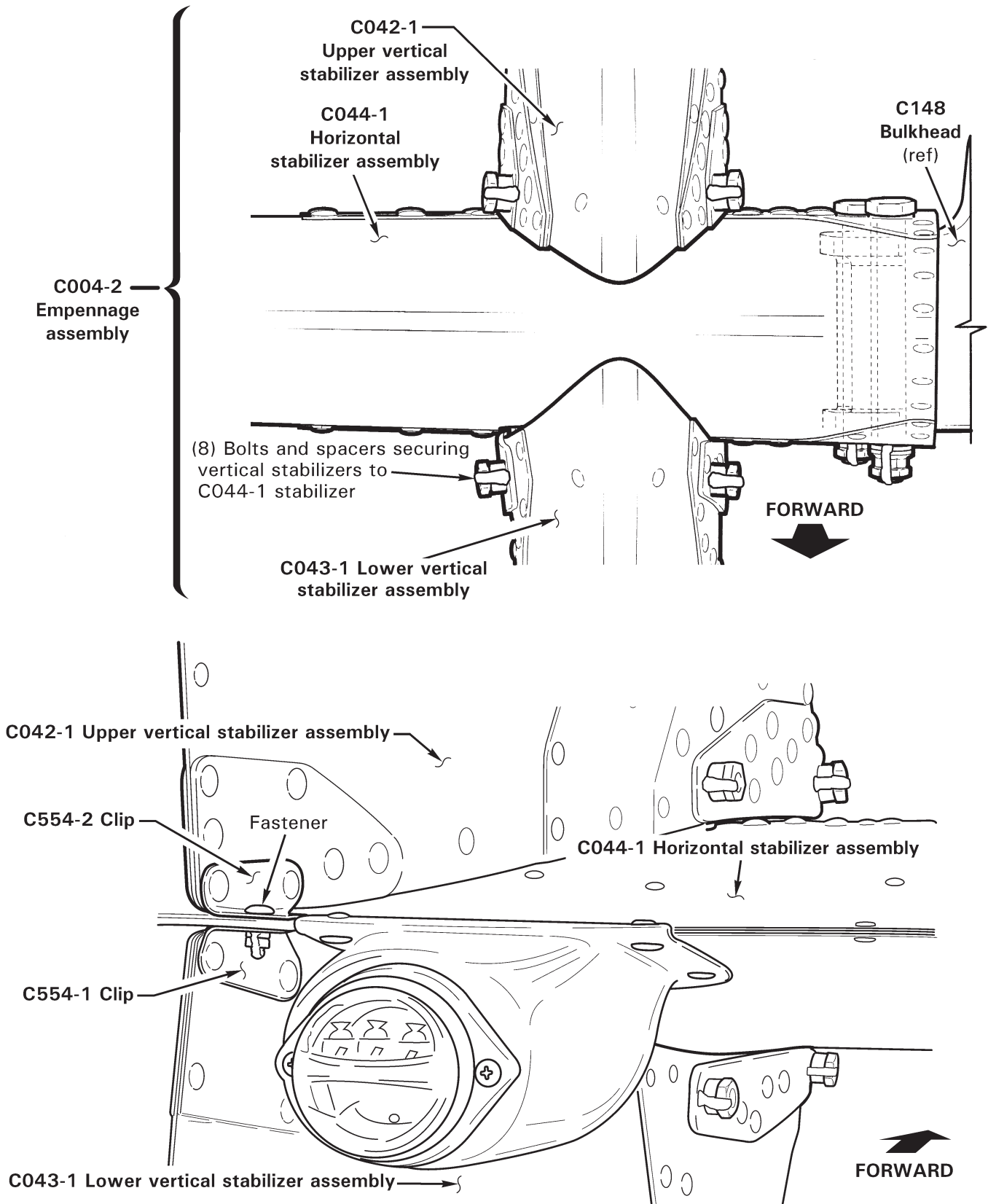

FIGURE 4-7A C004-2 EMPENNAGE ASSEMBLY

4.610 Upper Vertical Stabilizer Assembly

A. Removal

1. Refer to Figure 4-7 or 4-7A. Remove fastener securing C554-1 & -2 clips.
2. Support the C042-1 upper vertical stabilizer, remove (4) bolts & spacers securing stabilizer and remove stabilizer.
3. If replacing C042-1 stabilizer, C554-2 clip may be reused. Drill out two rivets securing clip to C042-1 stabilizer and remove clip.

B. Installation

1. Refer to Figure 4-7 or 4-7A. Position C042-1 upper vertical stabilizer assembly on mounting channels and align holes. Verify 0.030–0.120 inch gap between vertical stabilizer bottom edge and adjacent skin. File vertical stabilizer bottom edge as required. Conversion coat & prime bare aluminum edges per §§ 23-51 & 23-60.
2. Install bolts & spacers securing vertical stabilizer to mounting channels. Special torque bolts per § 23-33 and torque stripe per Figure 2-1.
3. Install fastener securing C554-1 & -2 clips. If reusing C554-2 clip, install clip and fastener, and match drill clip to vertical stabilizer with #30 drill. Deburr holes and install rivets. Torque stripe fastener per Figure 2-1.

4.620 Lower Vertical Stabilizer Assembly

A. Removal

1. Remove tail rotor guard per § 4.400.
2. Refer to Figure 4-7 or 4-7A. Remove fastener securing C554-1 & -2 clips.
3. Support the C043-1 lower vertical stabilizer, remove (4) bolts & spacers securing stabilizer and remove stabilizer.
4. As required, remove (pop-out or fixed floats) C050-2 float stabilizer per § 4.700 and tail skid per § 4.800.
5. If replacing C043-1 stabilizer, C554-1 clip may be reused. Drill out two rivets securing clip to C043-1 stabilizer and remove clip.

B. Installation

1. Refer to Figure 4-7 or 4-7A. Position C043-1 lower vertical stabilizer assembly on mounting channels and align holes. Verify 0.030–0.120 inch gap between vertical stabilizer upper edge and adjacent skin. File vertical stabilizer upper edge as required. Conversion coat & prime bare aluminum edges per §§ 23-51 & 23-60.
2. Install bolts & spacers securing vertical stabilizer to mount (or C044-1 stabilizer). Special torque bolts per § 23-33 and torque stripe per Figure 2-1.
3. Install fastener securing C554-1 & -2 clips. If reusing C554-1 clip, install clip and fastener, and match drill clip to vertical stabilizer with #30 drill. Deburr holes and install rivets. Torque stripe fastener per Figure 2-1.
4. Install (pop-out or fixed floats) C050-2 float stabilizer per § 4.700, as required. Install tail skid per § 4.800, if removed.
5. Install tail rotor guard per § 4.400.

4.630 F044-1 Vertical Stabilizers Mount Assembly

A. Removal

1. Remove C042-1 & C043-1 vertical stabilizer assemblies per §§ 4.610 & 4.620.
2. Remove hardware securing forward clamp to F044-1 vertical stabilizers mount assembly. Cut and discard ty-raps securing position light and gearbox chip detector wires and connectors together. Disconnect position light at connectors.
3. Support the mount assembly, remove hardware securing mount to C148 bulkhead and remove mount.

B. Installation

CAUTION

F044-1 vertical stabilizers mount assembly may only be installed on a tailcone that has an F955-1 bracket.

1. Position F044-1 vertical stabilizers mount assembly on C148 bulkhead.
 - a. **If D301 (empennage ballast; ref. § 1.242) weights will not be installed:** Install (2) NAS6606-47 bolts & associated hardware securing empennage to C148 bulkhead. Use (1) or (2) NAS1149F0663P washers under nut as required to meet § 23-30 Part E.5. Standard torque bolts and palnuts per § 23-32 and torque stripe per Figure 2-1.
 - b. **If D301 (empennage ballast; ref. § 1.242) weights will be installed:** Install (2) NAS6606-78 bolts & associated hardware securing empennage to C148 bulkhead. Use (1) or (2) NAS1149F0663P washers under nut as required to meet § 23-30 Part E.5; 1–4 threads may be exposed beyond primary nut. Standard torque bolts and palnuts per § 23-32 and torque stripe per Figure 2-1.
2. Install C042-1 & C043-1 vertical stabilizer assemblies per §§ 4.610 & 4.620.
3. If mount assembly was replaced, match drill C554-1 & -2 clips 0.144-inch diameter hole through mount. Deburr hole and install fastener.
4. Connect position light at connectors. Install hardware securing forward clamp to mount assembly. Install MS3367-4-9 or -5-9 ty-raps as required to secure position light and gearbox chip detector wires and connectors together. Cinch ty-raps until snug without over-tightening, and trim tips flush with heads.
5. Test and verify correct function of position and TR chip light circuits.

4.640 C044-1 Horizontal Stabilizer

A. Removal

1. Remove C042-1 & C043-1 vertical stabilizer assemblies per §§ 4.610 & 4.620.
2. Remove hardware securing forward clamp to C044-1 horizontal stabilizer assembly. Cut and discard ty-raps securing position light and gearbox chip detector wires and connectors together. Disconnect position light at connectors.
3. Support the stabilizer, remove hardware securing stabilizer to C148 bulkhead and remove stabilizer.

B. Installation

CAUTION

C044-1 horizontal stabilizer may not be installed on a tailcone that has an F955-1 bracket.

1. Position C044-1 horizontal stabilizer assembly on C148 bulkhead.
 - a. **If D301 (empennage ballast; ref. § 1.242) weights will not be installed:** Install (2) NAS6606-47 bolts & associated hardware securing empennage to C148 bulkhead. Use (1) or (2) NAS1149F0663P washers under nut as required to meet § 23-30 Part E.5. Standard torque bolts and palnuts per § 23-32 and torque stripe per Figure 2-1.
 - b. **If D301 (empennage ballast; ref. § 1.242) weights will be installed:** Install (2) NAS6606-78 bolts & associated hardware securing empennage to C148 bulkhead. Use (1) or (2) NAS1149F0663P washers under nut as required to meet § 23-30 Part E.5; 1–4 threads may be exposed beyond primary nut. Standard torque bolts and palnuts per § 23-32 and torque stripe per Figure 2-1.
2. Install C042-1 & C043-1 vertical stabilizer assemblies per §§ 4.610 & 4.620.
3. If horizontal stabilizer was replaced, match drill C554-1 & -2 clips 0.144-inch diameter hole through horizontal stabilizer. Deburr hole and install fastener.
4. Connect position light at connectors. Install hardware securing forward clamp to horizontal stabilizer. Install MS3367-4-9 or -5-9 ty-raps as required to secure position light and gearbox chip detector wires and connectors together. Cinch ty-raps until snug without over-tightening, and trim tips flush with heads.
5. Test and verify correct function of position and TR chip light circuits.

4.640 C044-1 Horizontal Stabilizer (continued)**C. Repair**

A single dent on C044-1 horizontal stabilizer leading edge outboard of vertical stabilizers is permitted provided:

1. Dent is no more than 0.050 inch deep.
2. Dent must have a smooth bottom, with minimum 0.125-inch radius, and no sharp nicks or cracks.
3. Dent must be less than 1.25 inches spanwise.
4. It is permissible to remove above dent via metalworking.

Depending on the damage, U.S. FAA AC (Advisory Circular) 43.13-1B may be used to repair some horizontal stabilizer minor skin damage; refer to the AC's Title Page for limitations. Use only 0.020-inch thick 2024T3 aluminum sheet for repairs; do not use thicker sheet. Skin replacement, damage to spars, and either forward or middle attachment for vertical stabilizers, is not field repairable.

To inspect spars, remove NAS1919B04S01 rivets securing D292-3 outboard rib. Only the inboard D292-2 nose rib or D292-3 outboard tip rib may be field replaced; all other parts require use of the factory jig.

4.700 C050-2 Float Stabilizer Assembly (Pop-Out or Fixed Floats)

CAUTION

C050-2 stabilizer must be installed if helicopter is equipped with pop-out or fixed floats.

A. Removal

1. Remove tail skid per § 4.800.
2. Using plastic scraper, remove sealant around edges where C050-2 float stabilizer assembly brackets attach to C043-1 lower vertical stabilizer assembly doublers. Remove C050-2 float stabilizer.

B. Installation

1. Position C050-2 float stabilizer on C043-1 lower vertical stabilizer. Install tail skid per § 4.800.
2. Seal C050-2 float stabilizer bracket edges to lower vertical stabilizer assembly doublers using B270-1 sealant.

4.800 Tail Skid

A. Removal

1. Refer to Figure 4-5. Support D079-1 tail rotor guard assembly. Remove hardware securing D081-2 block to C043-1 lower vertical stabilizer assembly and remove block.
2. Support C050-2 float stabilizer assembly, if installed, and C470-1 tail skid. Remove hardware securing D081-4 block assembly to C043-1 stabilizer and remove block.
3. Remove C470-1 tail skid from C043-1 stabilizer. Remove C470-3 spacer from skid, as required. Support tail rotor guard and float stabilizer while hardware is removed.

B. Installation

1. Refer to Figure 4-5. As required, install C470-3 spacer inside C470-1 tail skid wet with epoxy primer. Position tail skid inside C043-1 lower vertical stabilizer, position D081-4 block assembly and install hardware securing block assembly to stabilizer but do not torque at this time.
2. Position D079-1 tail rotor guard assembly & D081-2 block, install hardware securing block to stabilizer. Verify D081-2 & -4 blocks clamp tail rotor guard sleeve. For proper tail rotor guard-to-stabilizer clamping, first standard torque hardware securing tail skid per § 23-32, then special torque screw securing D081-2 block to D081-4 block per § 23-33. Torque stripe fasteners per Figure 2-1.

CHAPTER 5
LANDING GEAR

<u>Section</u>	<u>Title</u>	<u>Page</u>
5.000	Landing Gear	5.1
5.001	Introduction	5.1
5.002	Description	5.1
5.100	Landing Gear Assembly	5.1
5.110	Landing Gear Removal	5.1
5.120	Landing Gear Installation	5.5
5.200	Cross Tubes	5.5
5.210	Cross Tube Removal	5.5
5.220	Cross Tube Installation	5.6
5.300	Skid Tubes	5.6
5.310	Skid Tube Removal	5.6
5.320	Skid Tube Installation	5.6
5.330	Skid Shoe Replacement	5.6
5.340	Ground Handling Wheel Support Replacement	5.7
5.350	Skid Extension Replacement	5.7
5.400	Strut Fairings	5.7
5.410	Strut Fairing Removal	5.7
5.420	Strut Fairing Installation	5.8
5.500	Utility Float Landing Gear	5.9
5.510	Utility Float Landing Gear Removal	5.9
5.520	Utility Float Landing Gear Installation	5.11
5.530	Utility Float Tube Removal	5.11
5.540	Utility Float Tube Installation	5.11
5.600	Emergency Pop-Out Float Landing Gear	5.12
5.610	Pop-Out Float Removal	5.12
5.620	Pop-Out Float Installation	5.13
5.630	Leak Check	5.15
5.640	Emergency Inflation Test	5.16
5.650	Pop-Out Float Packing Procedure	5.18

CHAPTER 5

LANDING GEAR (Continued)

<u>Section</u>	<u>Title</u>	<u>Page</u>
5.660	Pressure Cylinder Removal	5.21
5.665	Filling Pressure Cylinder	5.22
5.670	Pressure Cylinder Installation	5.24
5.680	Inflation Lever Rigging	5.27
5.690	Inflation Lever Shear-Rivet Replacement	5.27
5.700	Maintenance	5.29

CHAPTER 5
LANDING GEAR

5.000 Landing Gear

5.001 Introduction

This section covers the removal and installation of the landing gear assembly, cross tubes, skid tubes, skid shoes, ground handling wheel supports, and strut fairings.

5.002 Description

Standard landing gear consists of two aluminum skid tubes, four steel struts with forged aluminum elbows, and two aluminum cross tubes. The landing gear connects to the fuselage at each elbow. Aerodynamic fairings are clamped to each strut. The right forward connection is to a pivoting shackle which allows the forward cross tube to flex. The right, aft connection is to a flexible steel tube frame which allows the aft cross tube to flex. Skid shoes, constructed of 4130 steel with a hard wear surface, protect the underside of the skid tubes during landing.

R44 Clippers have permanently inflated utility floats or emergency pop-out floats mounted to skid tubes and incorporate extended steel struts and aft skid extensions to support the floats. Strut fairings are not installed with utility floats.

5.100 Landing Gear Assembly

5.110 Landing Gear Removal

1. Remove C388 channels and C475 cover at forward cross tube.
2. Remove D040 aft engine cowling and D041 engine belly cowling.
3. Disconnect A936 ground wire at aft, right elbow.
4. Hoist helicopter by main rotor hub per Section 1.220 until skids clear ground by approximately 4 inches.
5. Remove four NAS6607 landing gear mounting bolts. Remove forward, left mounting bolt first. Then rotate forward, right shackle to align mounting bolt with access hole in bulkhead before removing bolt. Forward bolts can be accessed from inside aft baggage compartments and through access holes under carpet at aft outboard corners of aft floor.

LANDING GEAR INSTALLATION

<u>Item</u>	<u>Part Number</u>	<u>Description</u>
1	A214-10	Washer
2	C014-10	Strut Assembly (fwd)
3	C105-1	Journal
4	LJS-1016	Bearing
5	C014-5	Shackle Assembly
6	C141-5	Washer
7	AN960-716L	Washer
8	D310-5	Aft Cowl Bracket, LH (shown)
	D310-6	Aft Cowl Bracket, RH (not shown)
9	B330-21	Palnut
10	NAS679A7	Nut
11	AN960-716	Washer
12	C278-1	Spacer
13	C241-1	Cross Tube (rear)
14	C014-9	Strut Assembly (rear)
15	C241-2	Cross Tube (fwd)
16	C141-6	Washer
17	C294-2	Bearing Assembly
18	C141-4	Washer
19	NAS6607-53	Bolt
20	A141-11	Washer
21	NAS6604-17	Bolt
22	C014-7	Support Assembly
23	C240-1	Elbow
24	NAS1291-4	Nut
25	C247-2	Rain Cap
26	NAS6604-41	Bolt
27	AN960-416L	Washer
28	A31007	Nut
29	S14119	Screw

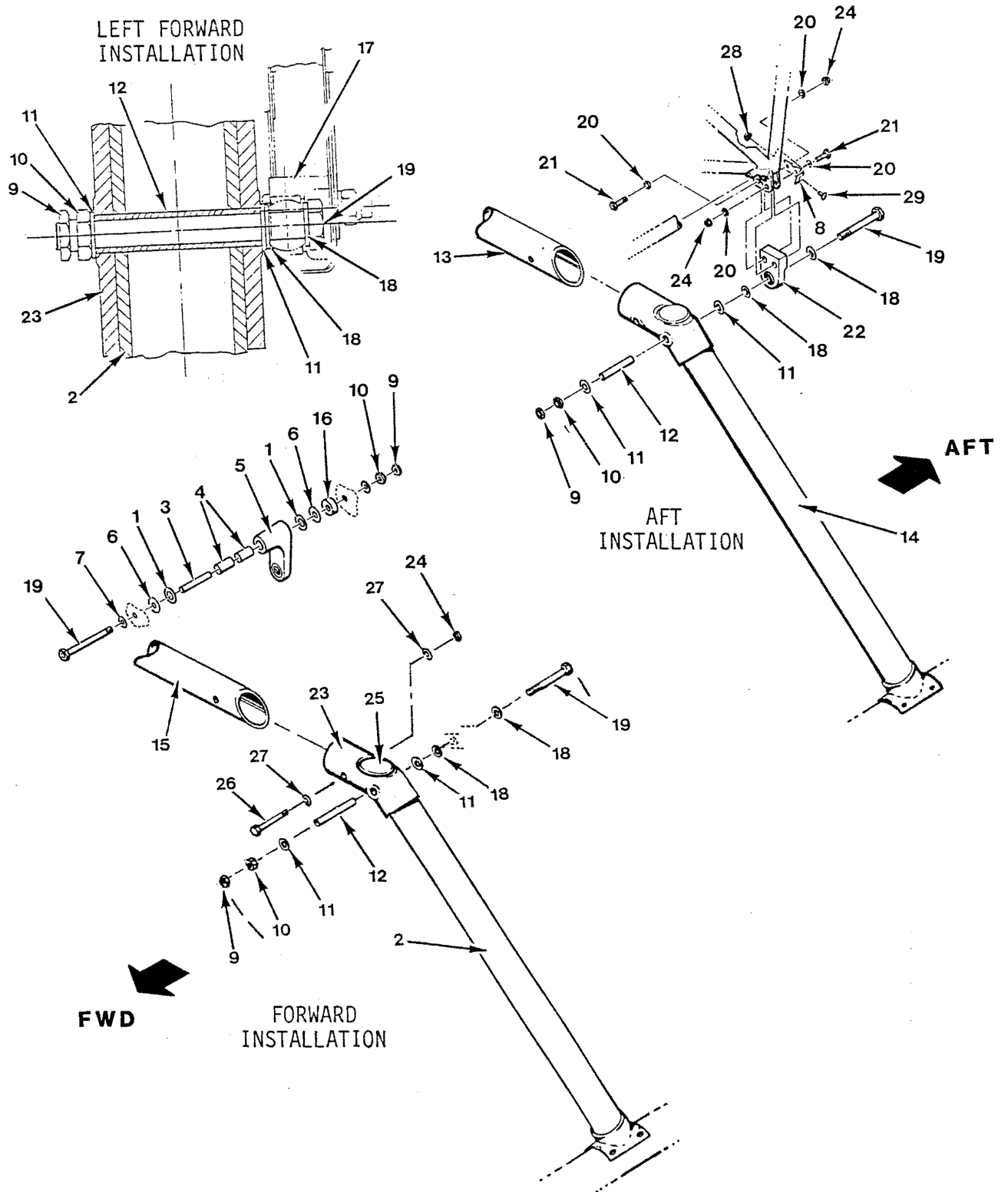

FIGURE 5-1 LANDING GEAR INSTALLATION

This page intentionally left blank.

5.120 Landing Gear Installation

- a) Hoist the helicopter per Section 1.
- b) Lift the right side of the landing gear and install both right side mounting bolts per Figure 5-1. Torque per Section 1.320, install palnuts, and torque stripe. Repeat on left side.
- c) Connect ground wire at right aft elbow and attach battery drain tube to aft cross tube.
- d) Install the C475-2 cover and the C388-1 channels at the forward cross tube.
- e) Install all cowling.

5.200 CROSS TUBES

5.210 Cross Tube Removal

The aft cross tube must be replaced if it has yielded so that the tail skid is less than 30 inches from the ground.

NOTE

For hard landing inspection, see Section 2.550.

- a) Remove landing gear per Section 5.110.
- b) Disconnect one of the struts from the skid tube.
- c) Remove the bolts in the elbows at each end of the cross tube and tap the elbows off of the cross tube.

5.220 Cross Tube Installation

- a) Install cross tube into the elbows and install bolts per Figure 5-1. Torque bolts per Section 1.320.
- b) Connect the unbolted strut to the skid tube and torque the NAS6606-4 bolts per Section 1.320.
- c) Install landing gear per Section 5.120.

5.300 SKID TUBES

5.310 Skid Tube Removal

- a) Raise one side of the helicopter by jacking under one end of the aft cross tube, one inch inboard of the elbow.
- b) Remove the 4 bolts at each landing gear strut. Remove the skid tube.
- c) Remove the C937 skid extension by removing the aft skid shoe. Remove the C719-1 wheel support.

5.320 Skid Tube Installation

- a) Install the C937 skid extension and aft skid shoe onto the C014-11 or -12 skid tube assembly. Install the C719-1 wheel support and torque per Section 1.330; the reduced torque required by Section 1.330 is required to avoid damaging the skid tube.
- b) Place the skid tube assembly under the fore and aft gear struts and install the attach bolts. Torque the NAS6606-4 attach bolts per Section 1.320.
- c) Seal the slot in the side of the skid extension with B270-9 adhesive, if required.

5.330 Skid Shoe Replacement

The two A667-8 forward skid shoes and seven A667-7 skid shoes (four on the left skid and three on the right) are fastened with A142-1 screws. Use new screws when replacing shoes and torque to 27 in.-lb. Skid shoes must be replaced when the bottoms have worn to 0.050 inch thick at their thinnest point.

- a) To inspect or replace the aft shoe on each skid, install ground handling wheels to lift the helicopter or jack up the helicopter at the aft landing gear cross tube per Figure 5-3B. Remove and discard worn skid shoes and screws and replace.
- b) To inspect or replace all other skid shoes, install ground handling wheels, pull the tail down and place wood blocks under the skids to hold the skids up per Figure 5-3A. Replace any worn shoes.

5.340 Ground Handling Wheel Support Replacement

- a) Remove the two mounting bolts and remove the C719-1 support.
- b) Install the support using NAS6604-47 bolts and torque per Section 1.330. The reduced torque of Section 1.330 is required to avoid damaging the skid tube.

5.350 Skid Extension Replacement

- a) Raise one side of the helicopter by jacking under one end of the aft cross tube, one inch inboard of the elbow.
- b) Remove the aft skid shoe and remove the four bolts attaching the aft strut to the skid tube.
- c) Remove the C937-1 or -2 skid tube extension and replace.
- d) Attach the strut to the skid tube and torque the four NAS6606-4 bolts per Section 1.320. Install the skid shoe.
- e) Seal the slot in the side of the skid extension with B270-9 adhesive.

5.400 STRUT FAIRINGS

5.410 Strut Fairing Removal

- a) Loosen the clamps through the access hole on the inboard side of the fairing.
- b) Remove all screws along the trailing edge.
- c) Unscrew the clamps and slide the fairing off of the strut.

5.420 Strut Fairing Installation

- a) Verify that a B162-3 clip nut is installed at each hole at the trailing edge of the fairing and that the strut clamps pass through both of the clips riveted to the fairing.
- b) Slide the fairing onto the strut and loosely fasten the two clamps.
- c) Install and tighten all screws along the trailing edge.
- d) Position fairings by placing a long straight edge across both forward and aft fairings at the lower clamps (See below). The distance from the straight edge to the centerline of the trailing edge should measure 1.4 inches. Check for 0.10 inch clearance all around both ends of the fairing. Remove fairing to trim and reinstall, if required.
- e) Apply B270-10 adhesive to both clamp threads and torque per Section 1.330. Verify 1.4 inch dimension with the straight edge.

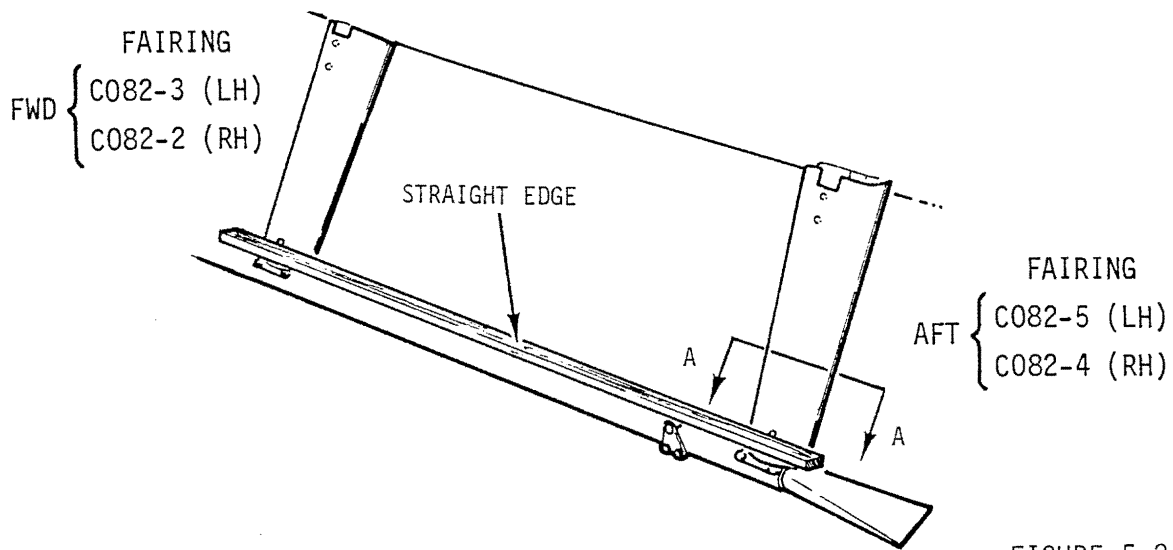
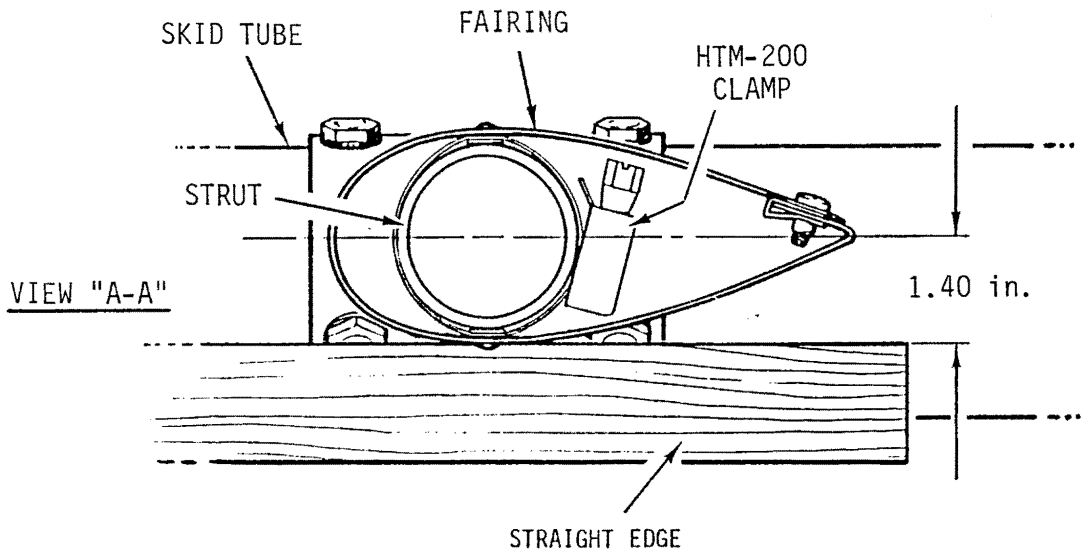

FIGURE 5-2



5.500 UTILITY FLOAT LANDING GEAR

The Robinson R44 Clipper helicopter may be flown with float landing gear or standard landing gear installed. When changing configurations, remove complete utility float landing gear and install complete standard landing gear. Do not remove float tubes from landing gear skid tubes unless necessary for repairs.

CAUTION

Float landing gear can only be installed on R44 Clipper helicopters.

5.510 Utility Float Landing Gear Removal

1. Remove float landing gear per Section 5.110.
2. Install standard landing gear per Section 5.120.
3. Remove C050 float stabilizer per Section 4.326.
4. Remove D372-2 air dams aft of static ports. Reinstall attaching screws.
5. Revise Equipment List/Weight and Balance data (located in helicopter Pilot's Operating Handbook, Section 6) using following information:

Part Number	Description	Weight (lb)	CG Arm (in.)	Moment (in.-lb)
C034-2	Utility Float Landing Gear	104.3	95.2	9929
C050-2	Utility Float Stabilizer	1.1	335.4	369
C014-8	Standard Landing Gear	60.9	86.3	5256

6. Perform flight check per Section 2.220.
7. Check and adjust autorotation RPM per Section 10.250 (usually requires lengthening pitch links approximately 1 full turn at upper rod end).

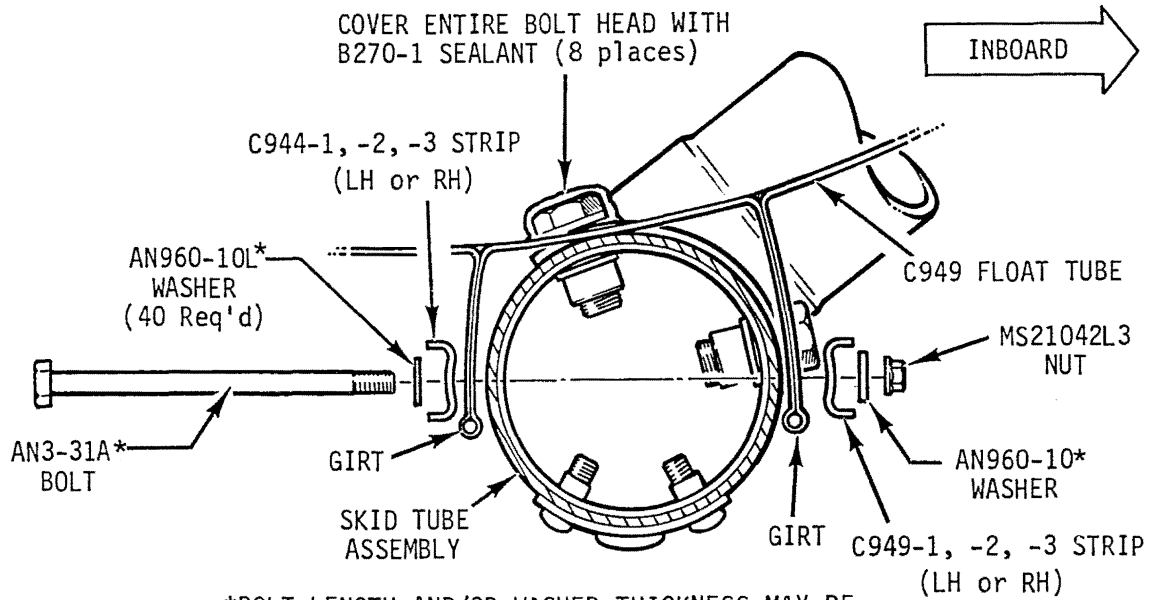

*BOLT LENGTH AND/OR WASHER THICKNESS MAY BE VARIED AS REQUIRED TO MAINTAIN 2-4 THREADS SHOWING BEYOND NUTS. SEAL UNDER HEAD AND NUT AND AROUND BOLT BETWEEN GIRTS AND SKID TUBE WITH B270-1 SEALANT.

FIGURE 5-3 UTILITY FLOAT ATTACHMENT
(LEFT SIDE SHOWN, VIEW LOOKING FORWARD)

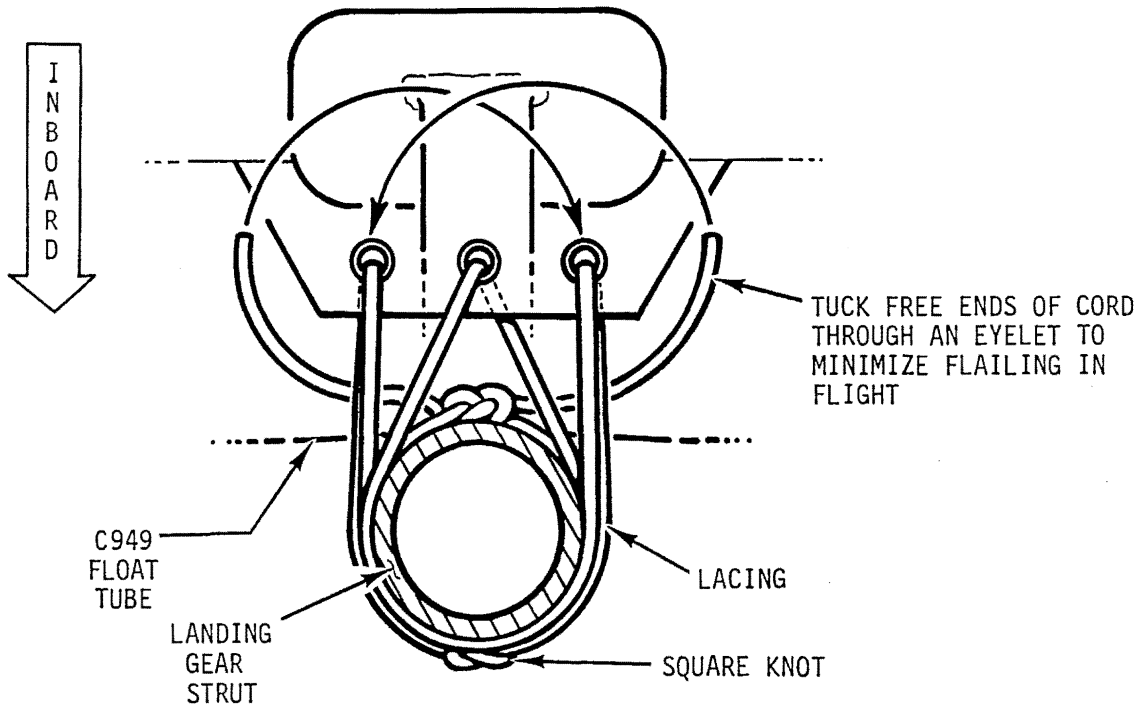

FIGURE 5-4 UTILITY FLOAT-TO-STRUT ATTACHMENT
(VIEW LOOKING DOWN)

5.520 Utility Float Landing Gear Installation

1. Remove standard landing gear per Section 5.110.
2. Install utility float landing gear per Section 5.120.
3. Install C050 float stabilizer per Section 4.327.
4. Adjust float pressure per helicopter's Pilot's Operating Handbook.
5. Install D372-2 air dams aft of static ports using existing screws.
6. Revise Equipment List/Weight and Balance data (located in helicopter's Pilot's Operating Handbook Section 6) using data provided in Section 5.510.
7. Shorten both main rotor pitch links by one full turn of upper rod end.
8. Perform flight check per Section 2.230.
9. Check and adjust autorotation RPM per Section 10.250.

5.530 Utility Float Tube Removal

1. Deflate float to loosen lacings.
2. Untie and remove lacings at each landing gear strut.
3. Remove hardware attaching float tube to skid tube and skid extension.
4. Remove retainer strips from girts. Carefully separate girt from skid tube and skid extension.

NOTE

Sealant between girt and skid tube at each bolt hole also acts as an adhesive. Use caution to avoid girt damage during removal.

5.540 Utility Float Tube Installation**NOTE**

Before installation, remove old sealant from skid, float, girts, and hardware. A soft plastic scraper may be used.

1. See Figure 5-3. Ensure bolt heads directly beneath float are covered with a protective layer of B270-1 sealant (see Section 1.480). Apply additional sealant as required.
2. See Figure 5-3. Position uninflated float tube over landing gear skid tube and extension. Align holes in C944 retainer strips, float tube girts, and skid tube.
3. Install AN3 attach bolts per Figure 5-3. Seal under bolt head and nut with B270-1 sealant (ref Section 1.480). Torque bolts per Section 1.320.

5.540 Utility Float Tube Installation (cont'd)

4. Inflate float with filtered, oil-free, dry air to pressure specified in Pilot's Operating Handbook.
5. Install and tighten lacing at each landing gear strut per Figure 5-4.

5.600 EMERGENCY POP-OUT FLOAT LANDING GEAR

Emergency pop-out floats are an option for R44 Clippers and replace permanently inflated utility floats. Included are extended struts, skid extensions, uninflated floats stowed in protective covers along skid tubes, a lightweight composite pressure cylinder located in the compartment under the left-front seat, an inflation manifold, an inflation lever located on the pilot's collective, and an additional horizontal stabilizer at base of lower vertical stabilizer. A valve atop the pressure cylinder incorporates a pressure gage, a thermal relief valve which releases pressure if exposed to excessive heat (281 degrees F), a metal sealing disk, and a spring-loaded pin. To inflate the floats, the red inflation lever on pilot's collective stick must first have its spring-loaded safety in the READY position and then the lever must be squeezed forcefully enough to shear an aluminum rivet. Squeezing the lever causes a spring-loaded pin to puncture the metal sealing disk and allows the 4945 psig (nominal, at 20°C) helium charge to inflate both floats via the manifold. The manifold consists of hoses with metal fittings incorporating a check valve at each float chamber. There are six chambers per float (earlier versions have five chambers). Each float chamber also has a topping valve for manual inflation and a pressure relief valve which vents excessive internal pressure. When inflated, pop-out floats are identical to utility floats in size, shape, and internal chamber arrangement.

If installing utility float or standard landing gear in place of pop-out floats, removal of pressure cylinder, inflation lever (including brackets and cable), and exterior hoses (cap pressure cylinder hose and T-fitting in forward cross tube tunnel) is required. Additionally, check autorotation RPM per Section 10.250 and update empty weight and balance.

WARNING

Cylinder contents are under extreme pressure. Install locking pin in pressure cylinder valve (see Figure 5-6) when working in forward left baggage compartment, during cylinder removal or installation, and when working on floats or inflation hoses. REMOVE LOCKING PIN WHEN WORK IS COMPLETED.

5.610 Pop-out Float Removal**NOTE**

To help prevent float damage, avoid removing floats from skid tubes unless necessary for repairs.

1. Remove heat-shrink and disconnect flexible line exiting forward strut fairing from T-fitting on float. Cap line and T-fitting to prevent contamination.

5.610 Pop-out Float Removal (cont'd)

2. Unfasten hook-and-loop fasteners along inboard sections of float cover to expose lacing. Loosen, but do not remove, lacing.
3. See Figure 5-5. Remove AN3 bolts attaching float to skid tube and skid extension.
4. See Figure 5-5. Remove C944 retainer strips from girts. Carefully separate girts from skid tube and skid extension.

NOTE

Sealant installed between girts and skid tube at each bolt hole also acts as an adhesive. Use caution to avoid girt damage during removal.

5.620 Pop-out Float Installation

NOTE

Before installation, remove old sealant from skids, floats, and hardware. A soft plastic scraper may be used.

WARNING

Cylinder contents are under extreme pressure. Install locking pin in pressure cylinder valve (see Figure 5-6) when working in forward left baggage compartment, during cylinder removal or installation, and when working on pop-out floats or inflation hoses. **Remove locking pin when work is completed.**

1. See Figure 5-5. Ensure strut bolt heads directly beneath float are covered with a protective layer of B270-1 sealant (see Section 1.480). Apply additional sealant as required.
2. See Figure 5-5. Position uninflated float over landing gear skid tube and skid extension. Align holes in C944 retainer strips, float cover, float girts, and skid.
3. Install AN3 attach bolts per Figure 5-5. Seal under bolt head, nut, and around bolt between girts and skid tube with B270-1 sealant (see Section 1.480). Torque bolts per Section 1.320.
4. Inflate float with filtered, oil-free, dry air to 3.0 psig via topping valves.
5. Slide heat-shrink over flexible line exiting forward strut fairing. Ensure heat-shrink is of sufficient length to cover all sharp edges and seal out water after activation. Remove protective caps and connect flexible line to float T-fitting. Orient connection as required to minimize preload. Torque fitting per Section 1.330. Position heat-shrink over fittings and shrink with heat gun, using a shield to protect float from heat.
6. Pack floats per Section 5.650.

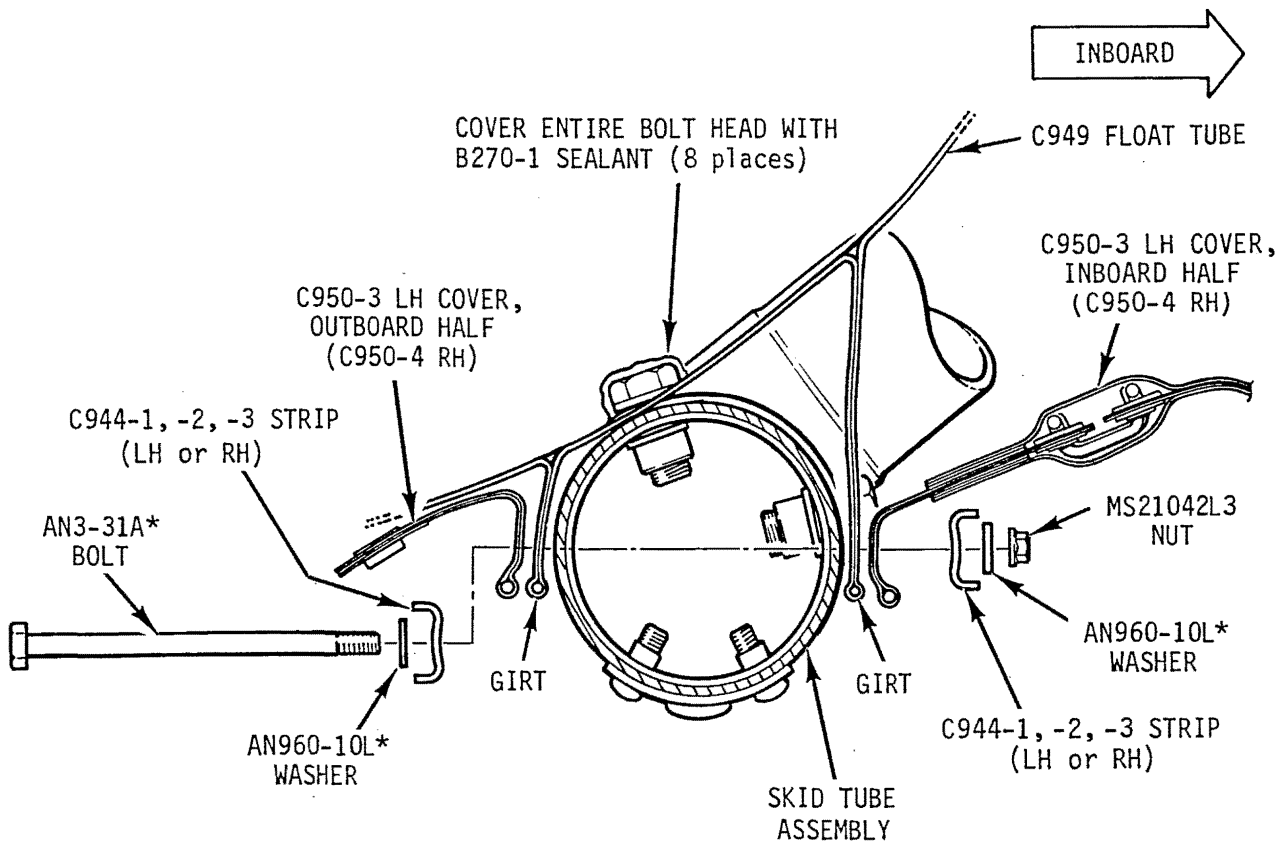

*BOLT LENGTH AND/OR WASHER THICKNESS MAY BE VARIED AS REQUIRED TO MAINTAIN 2-4 THREADS SHOWING BEYOND NUTS. SEAL UNDER HEAD AND NUT AND AROUND BOLT BETWEEN GIRTS AND SKID TUBE WITH B270-1 SEALANT.

FIGURE 5-5 POP-OUT FLOAT ATTACHMENT
(LEFT SIDE SHOWN, VIEW LOOKING FORWARD)

5.630 Leak Check**WARNING**

Cylinder contents are under extreme pressure. Install locking pin in pressure cylinder valve (see Figure 5-6) when working in forward left baggage compartment, during cylinder removal or installation, and when working on pop-out floats or inflation hoses. **Remove locking pin when work is completed.**

1. Disconnect D674-1 line assembly from pressure cylinder valve. Install protective cap on cylinder valve fitting. Cover D674-1 line fitting to prevent contamination, but do not install an air-tight seal (D674-1 line must be allowed to leak to verify check valve function at each float chamber).
2. Unfasten hook-and-loop fasteners along inboard sections of float cover to expose lacing. Loosen, but do not remove, lacing.
3. Unfasten outboard sections of float cover and unroll float to expose valves.
4. Inflate floats with filtered, oil-free, dry air to 2.0 psig via topping valves.
5. Allow float air temperature to stabilize for 5 minutes minimum then record OAT and pressure in each float chamber.
6. One to two hours after initial pressure check, again record OAT and pressure in each float chamber. Allowable chamber pressure drop from initial measurement is 0.2 psig adjusted for any temperature change. Pressure will change by 0.06 psig per degree C temperature change. For example, float chamber pressure will decrease 0.6 psig if temperature drops 10 degrees C.
7. If leaks are detected, repair float with supplied repair kit and repeat steps 4, 5, & 6.
8. Connect D674-1 line assembly to cylinder valve and torque per Section 1.330.
9. Pack floats per Section 5.650.

NOTE

Annually apply A257-7 dry-film lubricant (see Section 1.470) to float cover snap mating surfaces.

5.640 Emergency Inflation Test

WARNING

Cylinder contents are under extreme pressure. Install locking pin in pressure cylinder valve (see Figure 5-6) when working in forward left baggage compartment, during cylinder removal or installation, and when working on pop-out floats or inflation hoses. **Remove locking pin when work is completed.**

1. Unsnap outboard edge of both float covers. Hook-and-loop fasteners (inboard) may remain secured.
2. Remove locking pin from valve, move inflation lever safety to READY position, and verify area around floats is clear.
3. Squeeze inflation lever to inflate floats. Approximately 20 pounds force will be required due to the shear-riquet. Time for floats to attain full shape without wrinkles should be three seconds or less.

CAUTION

Floats inflate rapidly and with a loud noise. Keep area clear during inflation and inform all nearby personnel. Remove or close all doors prior to inflation. Open doors interfere with float inflation and may be damaged.

4. Allow float temperatures to stabilize for at least five minutes then record OAT and pressure in each float chamber. Minimum allowable pressures are:

O.A.T (degrees C)	Minimum Pressure (psig) in Forward Two Chambers	Minimum Pressure (psig) in Middle Chamber	Minimum Pressure (psig) in Aft Two Chambers
5-9	1.30	1.00	0.60
10-14	1.60	1.30	0.90
15-19	1.90	1.60	1.20
20-24	2.20	1.90	1.50
25-29	2.50	2.20	1.80
30-34	2.80	2.50	2.10
35-39	3.10	2.80	2.40

5.640 Emergency Inflation Test (continued)

5. Disconnect D674-1 hose assembly from pressure cylinder valve immediately after initial pressure check. Install protective cap on cylinder valve fitting. Cover D674-1 hose fitting to prevent contamination, but do not install an air tight seal (D674-1 hose must be allowed to leak to verify check valve function at each float chamber).
6. Verify no rips or chafing on floats or covers.
7. One to two hours after initial pressure check, again record OAT and pressure in each float chamber. Allowable chamber pressure drop from initial measurement is 0.20 psi adjusted for any temperature change. Pressure will change by 0.06 psi per degree C temperature change. For example, float chamber pressure will decrease 0.6 psig if temperature drops 10 degrees C.
8. If leaks are detected, repair float with supplied repair kit then perform leak check per § 5.630 on repaired float chamber.
9. Connect D674-1 hose assembly to valve fitting. Orient line as required to maintain minimum 0.25 inch clearance to cylinder and C390-5 panel. Torque B-nut per § 23-33 and torque stripe.
10. Pack floats per § 5.650.

NOTE

Annually apply A257-7 dry-film lubricant (see § 23-78) to float cover snap mating surfaces.

11. Remove D679 pressure cylinder assembly per § 5.660 and return to RHC for servicing.
12. Install serviceable pressure cylinder per § 5.670.
13. Rig inflation lever per § 5.690.
14. Replace inflation lever shear rivet per § 5.680.

5.650 Pop-out Float Packing Procedure

1. With float inflated, verify tees are oriented to minimize preload on hoses. Deflate float. Verify float is properly secured to skid and all hoses are properly connected and covered with heat shrink.
2. Spread deflated float to outboard side of skid tube. Using a vacuum, evacuate each float chamber through topping valve to remove as much air as possible.
3. Using a cloth covered with talcum powder, lightly coat entire float, including inside of covers.
4. Fold front end of float under and back until fold line reaches girt:

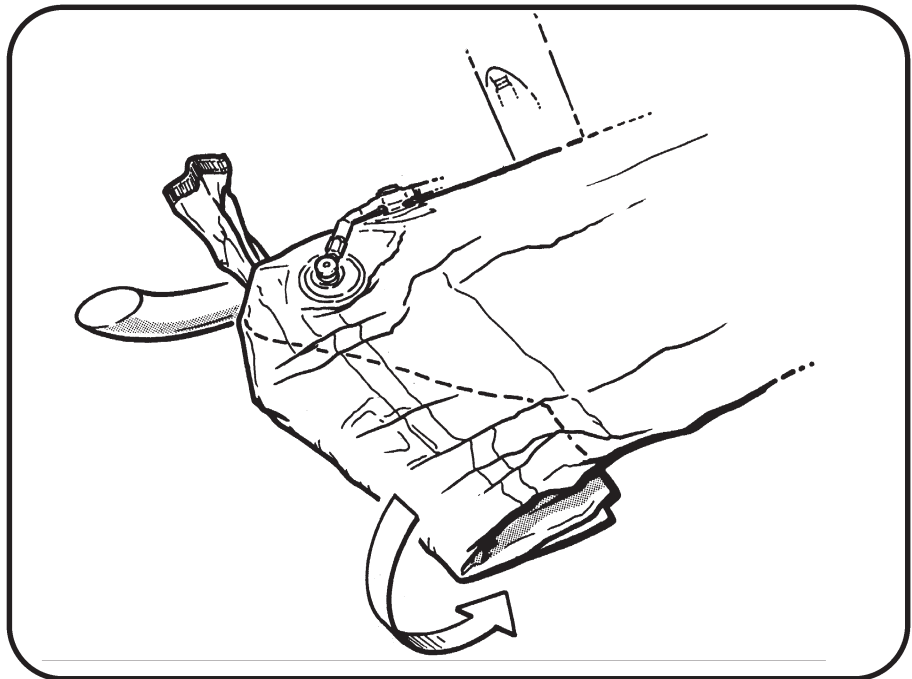

5. Fold aft end of float over and forward until fold line reaches girt:

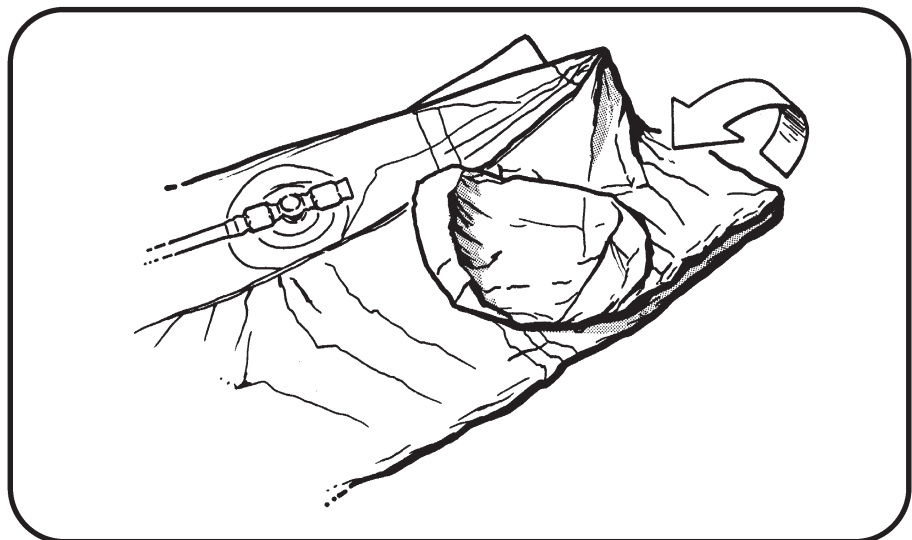

5.650 Pop-out Float Packing Procedure (cont'd)

- 6. Secure hook-and-loop fasteners at inside of inboard girt along length of cover:

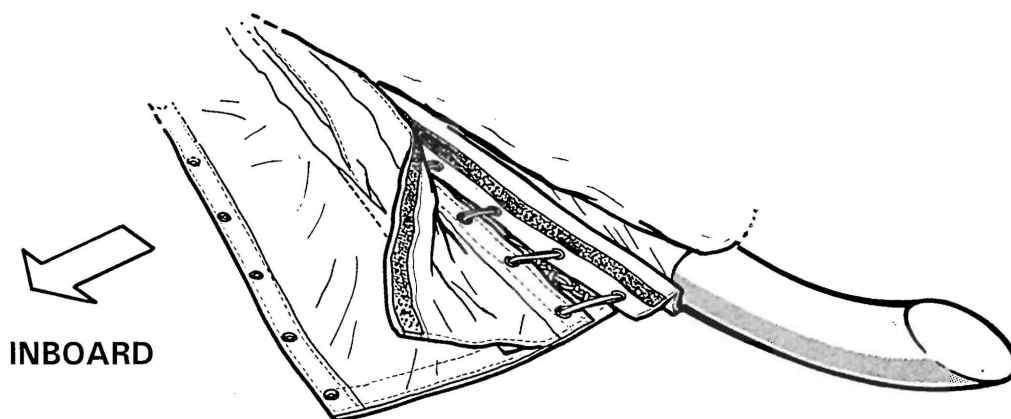

- 7. Align hoses and valve cover flaps and roll float from outer edge toward skid as tightly as possible:

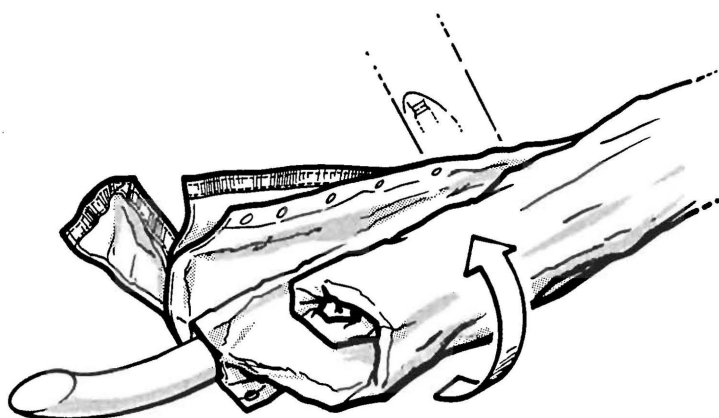

5.650 Pop-out Float Packing Procedure (cont'd)

8. Hold float on top of skid tube and install cover around float. Using a swab or small brush, apply A257-7 lubricant to mating surfaces of snaps. Secure hook-and-loop and snap fasteners along outboard girt (see Figure 5-5).
9. There are two lacing cords per float. One cord secures the float cover on the skid aft extension. The remaining cord secures the float cover to the skid. Verify lacing cord installed through grommets in cover using crossover ("ladder" lacing) method shown below:

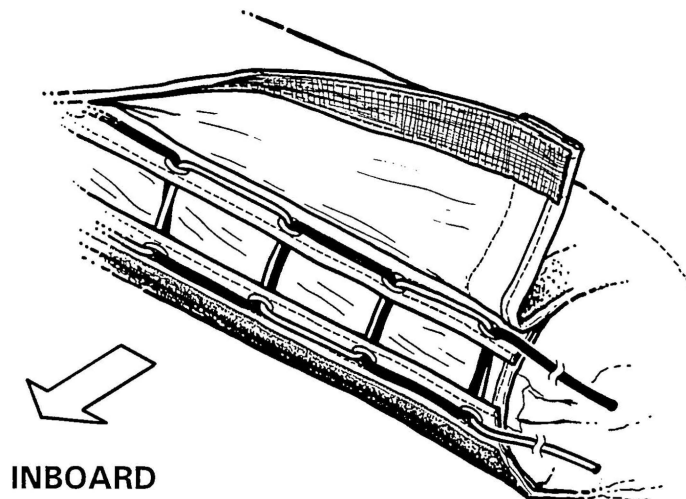

10. Pull lacing at each segment until tight or until material edges join; do not overtighten. Tie lacing ends in double square knots (4 alternating overhand knots) to secure.
11. Tuck in loose ends of lacing cord as shown and secure hook-and-loop fasteners along length of cover. Secure hook-and-loop fasteners at end caps:

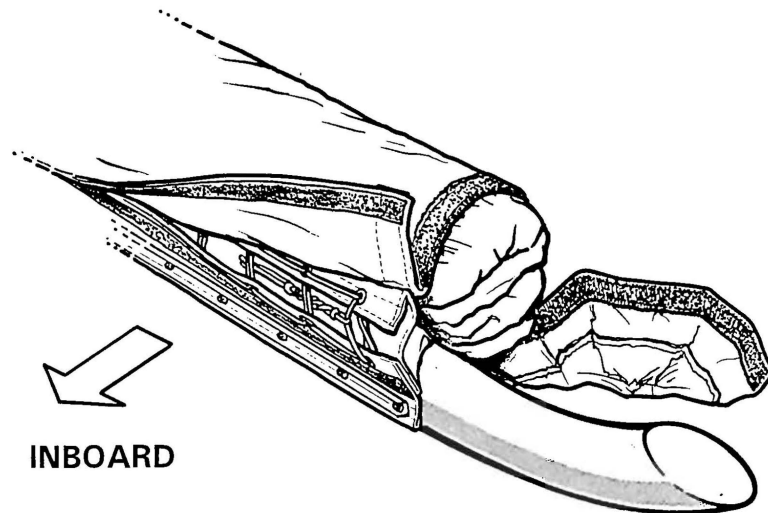

12. Verify all fasteners are properly secured and floats are rolled tightly with no lumps or loose areas.

5.660 Pressure Cylinder Removal (see Figure 5-6A)**WARNING**

Cylinder contents are under extreme pressure. Install locking pin in pressure cylinder valve (see Figure 5-6A) when working in forward left baggage compartment, during cylinder removal or installation, and when working on pop-out floats or inflation hoses.

1. Install locking pin in valve.
2. Disconnect D674-1 line assembly at valve fitting. Install protective caps on valve and line fittings.
3. Remove D675-9 cover.
4. On B125-2 connector, cut & remove ty-rap closest to valve. Disconnect connector from valve cable.
5. Disconnect D675-10 support from valve. Do not kink cable.
6. Remove D669-3 strap.
7. Carefully remove pressure cylinder.
8. If cylinder has been discharged, order KI-167 Cylinder Valve Service and Fill kit.

NOTE

If cylinder requires depressurization for transportation, use KI-151 Pop-Out Float Cylinder Bleed-Off Kit.

5.665 Filling Pressure Cylinder (See Figure 5-6)

WARNING

ONLY cylinders labeled "DOT-E 10915-4945" may be refilled. Cylinders labeled "DOT-E 10915-4500" must be returned to RHC for exchange/upgrade.

Maximum cylinder life is 15 years from date of manufacture and maximum hydro-test interval is 5 years. Also, maximum interval in aircraft between inspections is 3 years. Therefore returning to service cylinders older than 12 years or having hydro-tests older than 2 years is not recommended unless alternate arrangements are made to ensure life/hydro-test limits are not exceeded.

All fill equipment (pumps, hoses, fittings, etc.) must be rated for 6000 psi minimum working pressure and be in good condition.

Cylinder temperature and pressure must be kept within safe limits. Monitor pressure gauge and use thermocouple or other appropriate temperature probe to monitor temperature on face of thermal relief fitting during fill. Do not allow temperature to exceed 50°C (122°F) or pressure to exceed 5500 psig. If limits are approached, stop fill and allow cylinder to cool and pressure to drop before continuing. Placing cylinder in a water bath and using slow to moderate fill rates is recommended. If using water bath, keep water level below valve assembly to avoid water contamination of valve.

1. Remove fill-port cap.
2. Install MT546-2 Adapter Assembly per Figure 3 (Torque 40 in-lb).
3. Attach fill hose to MT546-2 Adapter Assembly.
4. Fill with 99.98% minimum purity (industrial grade) helium per chart below:

Ambient Temp (°C)	Pressure (psig)
-20	4268
-10	4437
0	4606
10	4776
20	4945
30	5114
40	5283

5. Allow cylinder and valve to cool to ambient temperature. Top off with helium to compensate for any pressure loss due to cooling.
6. Remove fill hose and re-install fill-port cap (Torque 40 in-lb).

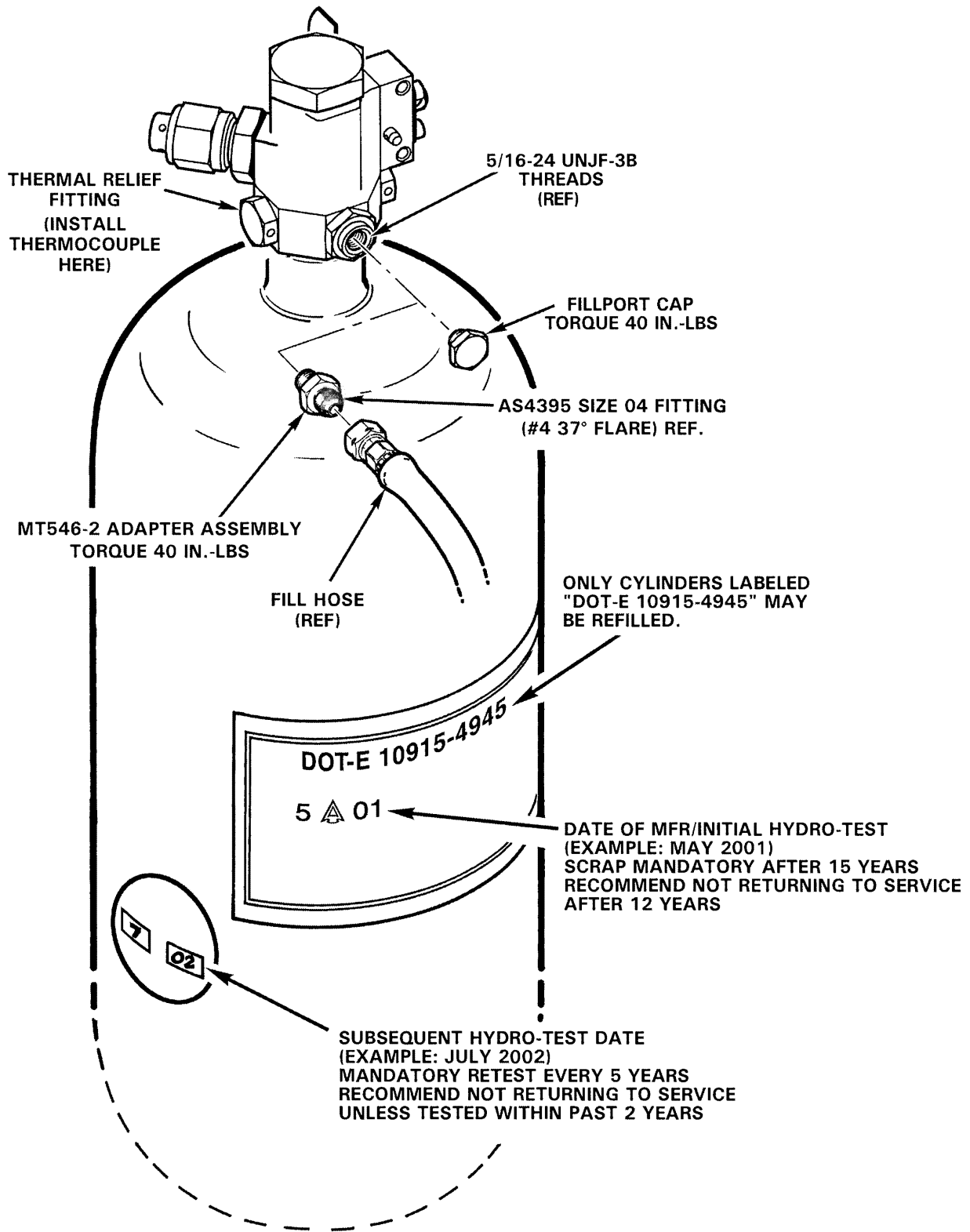

FIGURE 5-6 FILLING PRESSURE CYLINDER

5.670 Pressure Cylinder Installation (see Figure 5-6A)**WARNING**

Cylinder contents are under extreme pressure. Install locking pin in pressure cylinder valve (see Figure 5-6A) when working in forward left baggage compartment, during cylinder removal or installation, and when working on pop-out floats or inflation hoses. **Remove locking pin when work is completed.**

1. Install locking pin in valve.
2. Ensure cylinder's three forward contact areas are covered with anti-chafe tape.
3. Carefully position cylinder into D669 strap and D669 cradle per Figure 5-6A.
4. Install D675-10 support on valve.
5. See Figure 5-6B. Connect valve cable to B125-2 connector and secure with ty-rap. Verify dimension shown.
6. Install D675-9 cover on valve.
7. Rotate cylinder as required to minimize cable bending and ensure clearance with surrounding structure. Install D669-3 strap.
8. Connect D674-1 hose assembly to valve fitting. Orient line as required to maintain minimum 0.25 inch clearance to cylinder and C390-5 panel. Torque B-nut per Section 1.330 and torque stripe.
9. Rig inflation lever per Section 5.680.
10. Replace inflation lever shear rivet per Section 5.690.
11. Remove locking pin from valve.

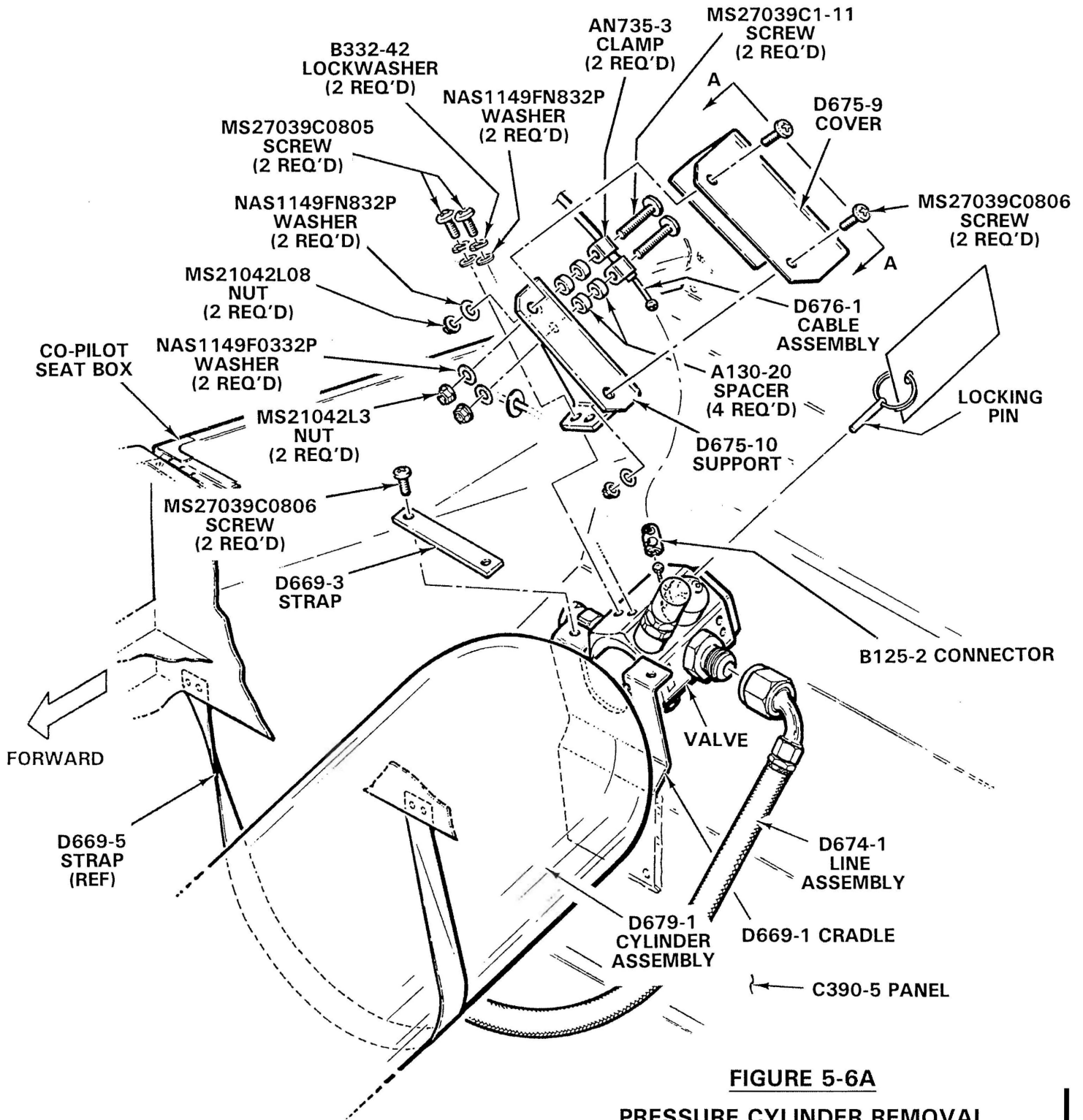
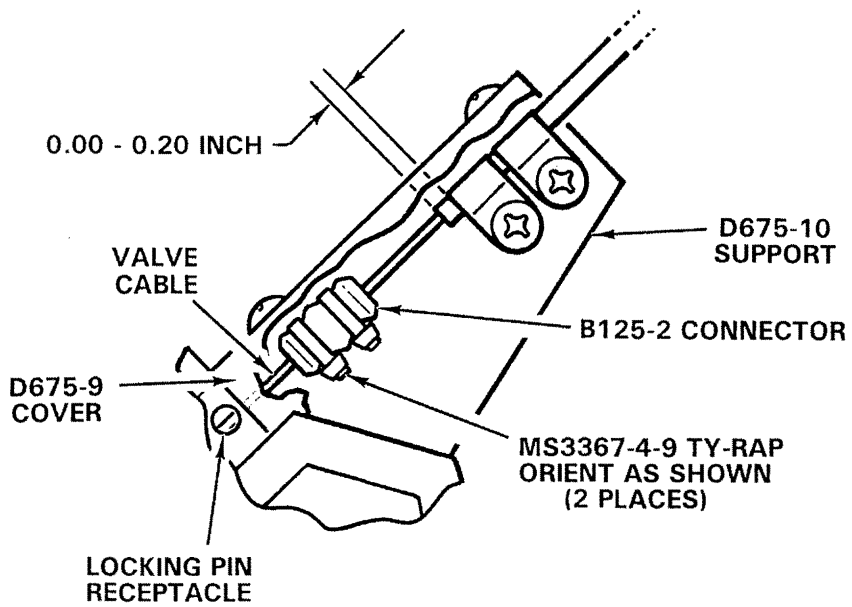

FIGURE 5-6A
PRESSURE CYLINDER REMOVAL
AND INSTALLATION



**VIEW A-A FROM FIGURE 5-6
(VIEW LOOKING FORWARD)**

FIGURE 5-6B

5.680 Inflation Lever Rigging**WARNING**

Cylinder contents are under extreme pressure. Install locking pin in pressure cylinder valve (see Figure 5-6A) when working in forward left baggage compartment, during cylinder removal or installation, and when working on pop-out floats or inflation hoses.

1. Install locking pin in valve.
2. See Figure 5-7. With inflation lever safety in READY position, collective full up, and no shear-rievet installed, verify 1.30/1.25 inch dimension shown when inflation lever is squeezed to eliminate slack. If required, reposition cable housing in clamps at inflation lever to obtain 1.30/1.25 inch dimension.
3. Place inflation lever safety in LOCKED position. Verify no preload in cable thru full travel of collective with inflation lever squeezed against safety.
4. Replace inflation lever shear rivet per Section 5.690.

5.690 Inflation Lever Shear-Rivet Replacement

1. Before installing rivet, verify inflation lever rigging per Section 5.680.

WARNING

Cylinder contents are under extreme pressure. Install locking pin in pressure cylinder valve (see Figure 5-6) when working in forward left baggage compartment, during cylinder removal or installation, and when working on pop-out floats or inflation hoses. Remove locking pin when work is completed.

2. Install locking pin in valve.
3. See Figure 5-7. Place inflation lever safety in LOCKED position.
4. Insert MS20470A2-6-5 (or MS20470A2-6.5) rivet per Figure 5-7.

WARNING

Use only MS20470A2 series annealed rivet in inflation lever assembly; other hardware may prevent float inflation.

5. Using locking pliers or similar, flatten shop-head end of rivet per Figure 5-8.
6. Remove locking pin from valve.

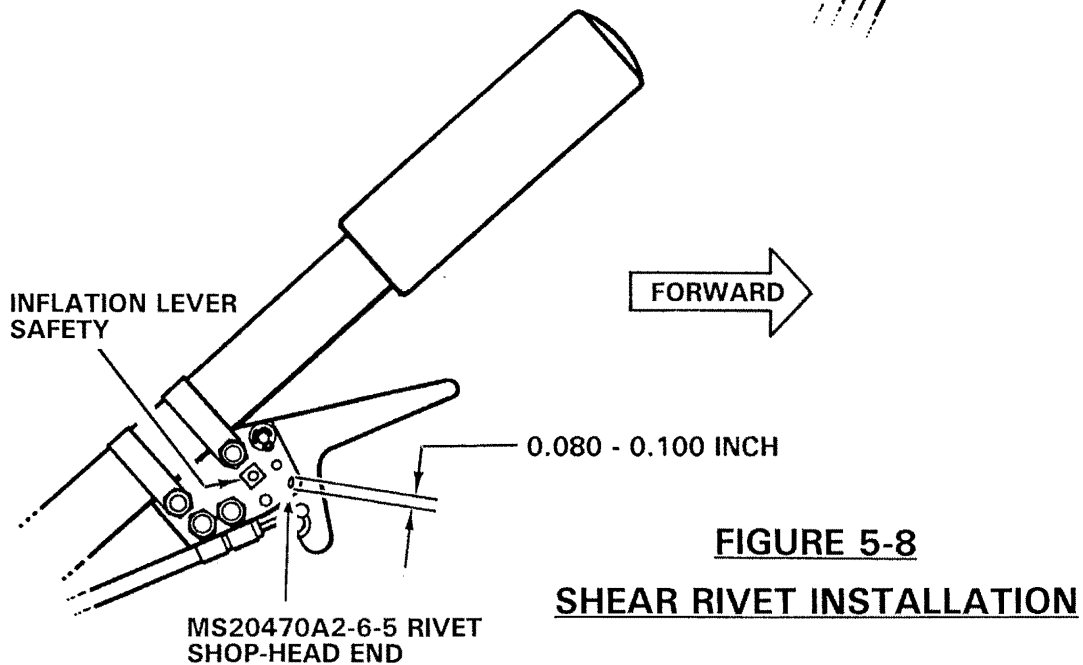
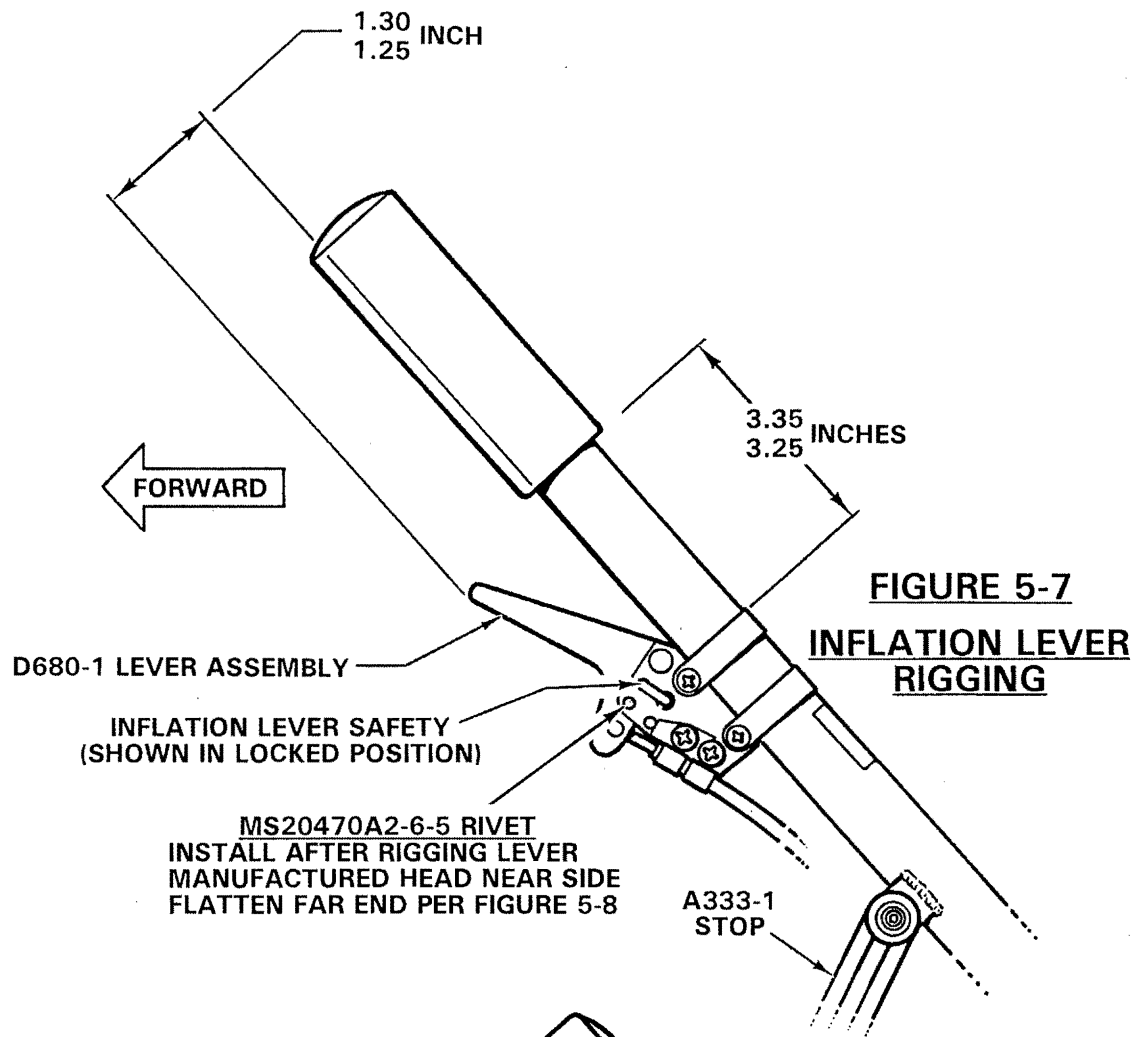

5.700 MAINTENANCE

1. Ensure drain holes in bottoms of skid tubes are not plugged (two per skid, standard and pop-out gear only), located between the two forward skid shoes and just aft of the skid shoe at the forward strut.
2. Touch up skid tubes, cross tubes and struts to prevent corrosion. See Section 1.400 for approved materials.
3. Inspect skid shoes frequently, especially following touch-down autorotations or running take-offs or landings.
4. Install lost or loose raincaps with B270-1 or B270-9 adhesive (see Section 1.480). Mix adhesive per manufacturer's instructions.

Intentionally blank

CHAPTER 6
POWERPLANT

<u>Section</u>	<u>Title</u>	<u>Page</u>
6.000	Powerplant and Related Systems	6.1
6.001	Introduction	6.1
6.002	Description	6.1
6.100	Powerplant	6.2
6.110	Engine Removal	6.2
6.120	Engine Installation	6.4
6.200	Cooling System	6.7
6.210	Fanwheel and Scroll Removal	6.7
6.220	Fanwheel and Scroll Installation	6.8
6.230	(Reserved)	
6.240	Fan Dynamic Balance	6.11
6.300	Lubrication System	6.12
6.310	Oil Cooler Removal	6.12
6.320	Oil Cooler Installation	6.12
6.400	Induction System	6.13
6.410	Carburetor Removal	6.13
6.420	Carburetor Air Box Removal	6.13
6.430	Carburetor Air Box Installation	6.13
6.440	Carburetor Installation	6.15
6.450	Carburetor Heat Scoop Removal	6.15
6.460	Carburetor Heat Scoop Installation	6.15
6.470	Fuel Injection Air Box Removal	6.15
6.480	Fuel Injection Air Box Installation	6.17
6.490	Fuel Control Removal	6.17
6.495	Fuel Control Installation	6.17
6.500	Exhaust System	6.20
6.510	Exhaust System Removal	6.20
6.520	Exhaust System Installation	6.20
6.600	Troubleshooting	6.21
6.610	Low-Power Checklist	6.21

Intentionally Blank

CHAPTER 6

POWERPLANT

6.000 Powerplant and Related Systems6.001 Introduction

This section includes instructions for the removal and installation of engine, induction system, lubrication system, cooling system and exhaust system. Refer to engine and engine component manufacturers' maintenance publications for product specific inspection, repair, and maintenance procedures.

6.002 Description

R44 helicopters are powered by one Textron-Lycoming O-540-F1B5 six-cylinder, horizontally opposed, overhead-valve, air-cooled, carbureted engine with a wet sump oil system normally rated at 260 horsepower and 2800 rpm for takeoff. The engine is derated to 205 maximum continuous horsepower (MCP), with a 5-minute takeoff power rating of 225 horsepower, by limiting manifold pressure (see Pilot's Operating Handbook) and RPM. At 102% tachometer indication the engine is actually turning 2718 RPM.

R44 induction air enters through a screened opening on the right side of the aircraft and passes through a flexible duct to the carburetor-mounted air box assembly. A scoop mounted to the exhaust manifold passes heated air via a duct to the air box. A cable-operated sliding valve in the air box controlled by the pilot allows either cool or warm air to flow into the box, through the radial-flow air filter and up into the carburetor. On R44 S/N 0202 and subsequent, application of carburetor heat is correlated with changes in collective setting through a friction clutch to reduce pilot workload. Lowering collective mechanically adds carb heat and raising collective reduces carb heat. The pilot may override the friction clutch and increase or decrease carb heat as desired. A latch is provided at the control knob to lock carb heat off when not required.

R44 II helicopters are powered by one Textron-Lycoming IO-540-AE1A5 six-cylinder, horizontally opposed, overhead-valve, air-cooled, wet-sump oil system, fuel-injected engine capable of 300 horsepower and normally rated at 260 horsepower and 2800 rpm for takeoff. The engine is derated to 205 horsepower MCP, with a 5-minute takeoff power rating of 245 horsepower, by limiting manifold pressure (see Pilot's Operating Handbook) and RPM. At 102% tachometer indication the engine is actually turning 2718 RPM.

R44 II induction air enters through a screened opening on the right side of the aircraft and passes through a radial-flow filter within an air box. The air then passes through a flexible duct, through the fuel control and into the engine. A spring-loaded door on top of the air box automatically opens to supply sheltered engine compartment air should filter or intake screen blockage occur.

Cooling is supplied by a direct-drive, centrifugal fanwheel enclosed by a fiberglass scroll. The scroll directs cooling air via flexible ducts to the muffler, the main rotor gearbox, the hydraulic reservoir (if installed), the drive belts, and engine-mounted sheet-metal cooling panels. The cooling panels also direct cooling air to the drive belts, and further guide cooling air to the cylinders, external oil cooler (two on R44 II), alternator, magnetos, fuel flow divider (fuel injected engines), and battery (when battery is mounted in engine compartment).

A sheave bolted to the propeller flange transfers engine power to the clutch assembly via four double v-belts engaged by a vertically mounted electric belt tension actuator.

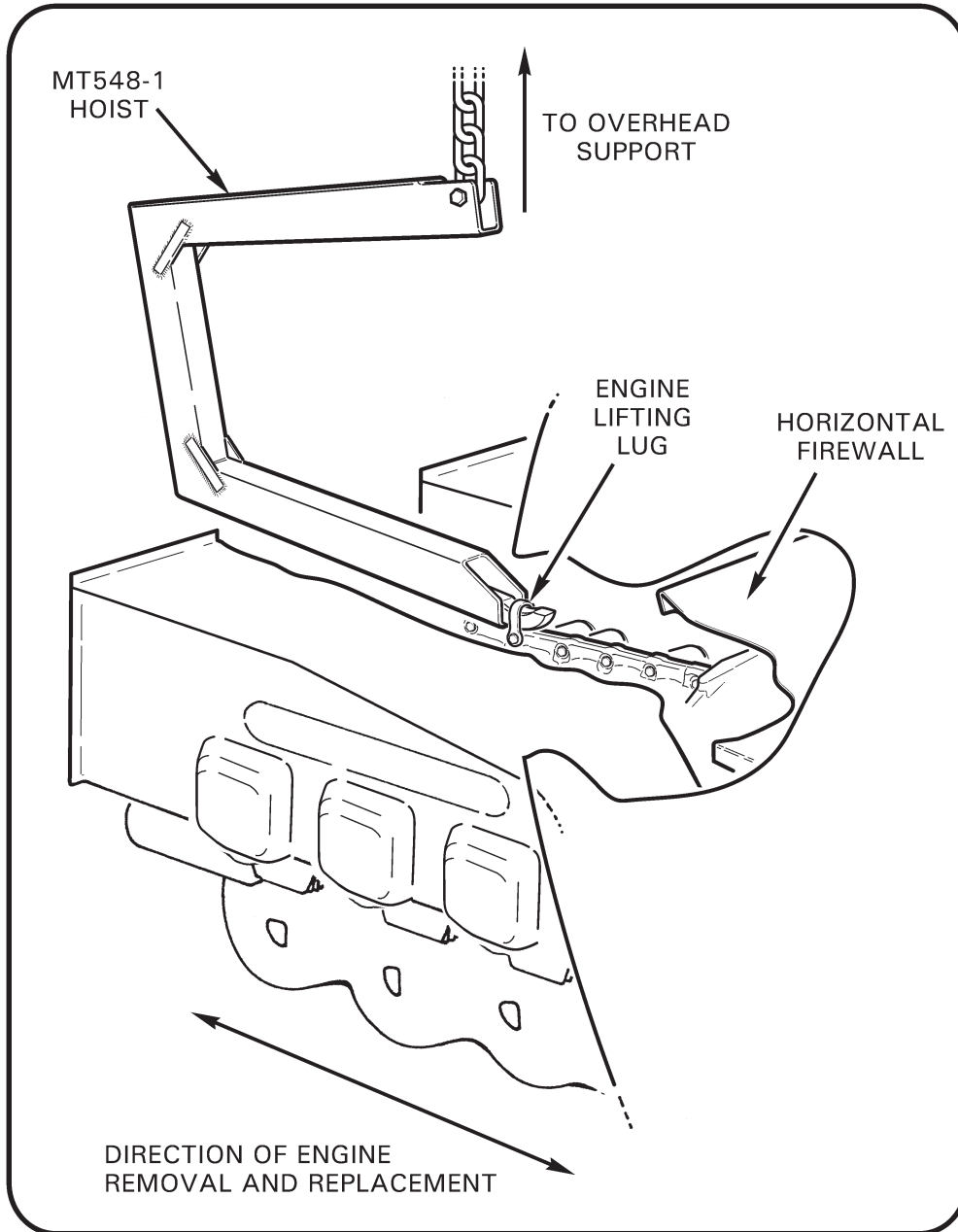

FIGURE 6-1 ENGINE HOISTING

6.100 Powerplant

NOTE

Refer to the appropriate engine and ignition manufacturers' maintenance publications for specific instructions.

6.110 Engine Removal

1. Remove tailcone cowling and all engine cowling.
2. Remove tailcone per § 4.300.

6.110 Engine Removal

3. Remove fanwheel and scroll assembly per § 6.210.
4. Remove clutch assembly, belt tension actuator, and V-belts per §§ 7.200, 7.510, & 7.281.
5. Disconnect engine breather tube at engine by removing one clamp from the rubber coupling. Cap exposed connections.
6. Turn fuel on-off valve to off position. Remove air box assembly and carburetor (if equipped) per § 6.410 or 6.460, as applicable.
7. Disconnect manifold pressure line from the forward left cylinder (O-540) or intake manifold (IO-540) and cap exposed connections.
8. Disconnect oil pressure hose and cap exposed connections.
9. **O-540:** If installed, disconnect primer line at T-fitting on engine and cap exposed connections.

IO-540: Disconnect fuel hose from engine-driven fuel pump inlet and disconnect fuel return hose from fuel control inlet T-fitting. Cap exposed connections.
10. Disconnect airframe and battery ground straps from engine oil sump bolts.
11. Tag for identification and disconnect alternator wiring, starter wiring, magneto-to-airframe wiring, cylinder head temperature sender wire and oil temperature sender wire.
12. Disconnect cabin heater duct from muffler shroud.
13. Support engine at bottom of lower sheave. Use a wood block to prevent damage to sheave.
14. Remove aft engine support assembly by disconnecting all four bolts.

NOTE

Avoid disconnecting rod ends from support assembly unless required. Dimensions shown in Figure 6-2 must be maintained.

15. Refer to Figure 6-1. Support engine at lifting lug using MT548-1 or -8 tool with a hoist.
16. Disconnect and remove two forward engine-mounting bolts.
17. Remove right, aft vertical strut weldment connecting lower right frame to upper frame.
18. On R44 IIs and later R44s, remove left, aft vertical strut weldment connecting lower left frame to upper frame.
19. Remove engine.

CAUTION

To prevent damage while removing the engine, someone should assist on each side of engine.

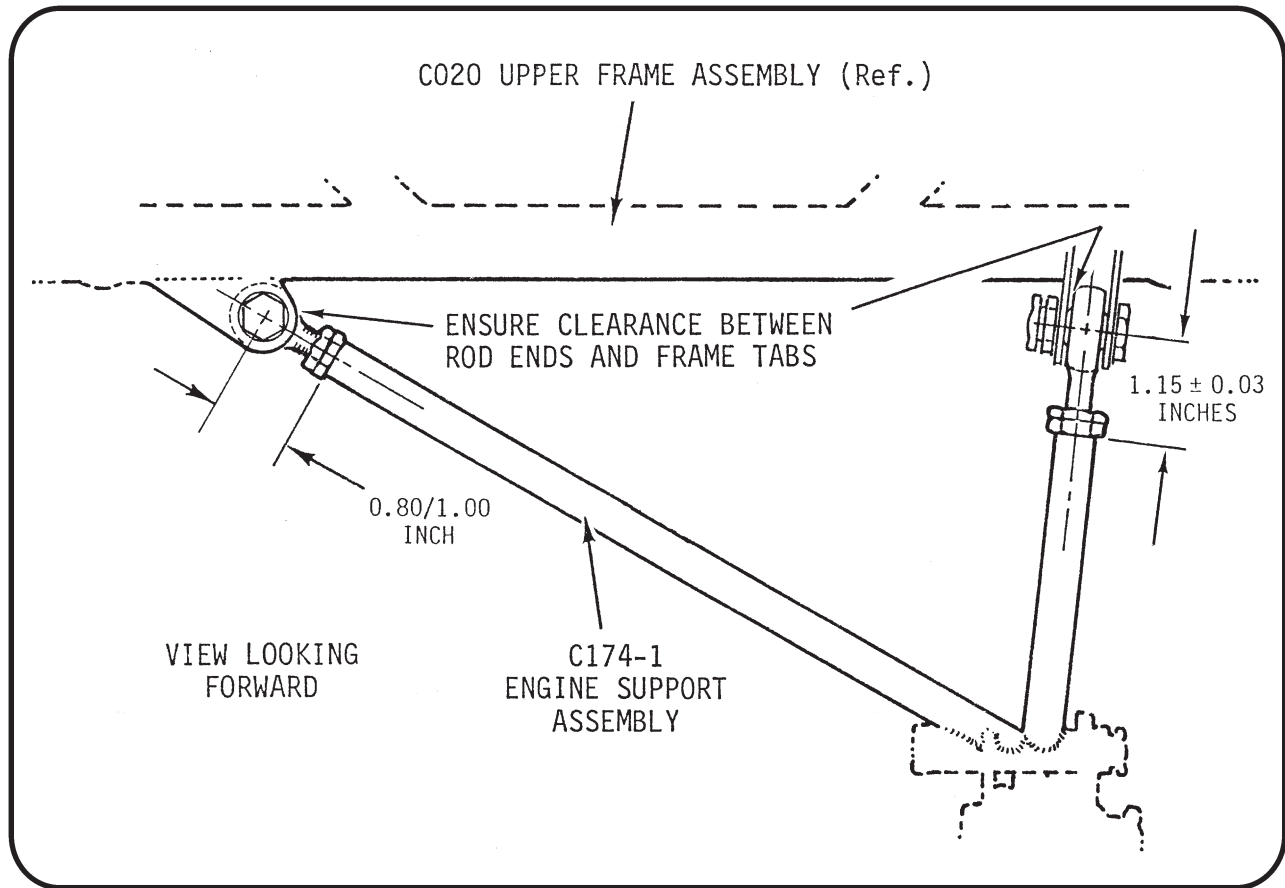

FIGURE 6-2 ENGINE AFT SUPPORT ASSEMBLY

6.120 Engine Installation

1. Refer to Figure 6-1. Connect MT548-1 or -8 tool to engine lifting lug. Carefully hoist engine and position it into alignment with engine mounting pads.
2. If applicable, install left, aft vertical strut weldment connecting lower left frame to upper frame. Standard torque hardware per § 1.320 and torque stripe per Figure 2-1.
3. Install right, aft vertical strut weldment connecting lower right frame to upper frame.
4. Install two forward engine mounting bolts. Standard torque hardware per § 1.320 and torque stripe per Figure 2-1.
5. Support weight of engine at bottom of lower sheave. Use a wood block to prevent damage to sheave. Remove hoist.
6. Connect aft engine support assembly. Standard torque hardware per § 1.320 and torque stripe per Figure 2-1.
7. Remove support from lower sheave.

6.120 Engine Installation (continued)

8. **O-540:** Install carburetor per § 6.440.

IO-540: Connect throttle linkage. Connect mixture control cable per Figure 6-7. Adjust cable so there is 0.03-0.10 inch clearance under mixture control knob (springback) when fully depressed and mixture arm is in full rich position.

9. Adjust throttle correlation rigging per § 10.150.

10. Connect cabin heater duct to muffler shroud.

11. Connect airframe and battery grounding straps to engine oil sump bolts and torque per § 1.330.

12. Connect alternator wiring, starter wiring, both magneto-to-airframe wiring, cylinder head temperature sender wire and oil temperature sender wire. Ty-rap as required.

13. Connect engine breather tube.

14. **O-540:** If installed, connect primer line to T-fitting on engine.

IO-540: Connect fuel hose to engine-driven fuel pump inlet and connect fuel return hose to fuel control inlet T-fitting. Torque per § 1.330.

15. Connect oil pressure hose.

16. Connect manifold pressure line.

17. Install fuel injection air box per § 6.480, if applicable.

18. Install V-belts, belt tension actuator, and clutch assembly per §§ 7.282, 7.520, and 7.220.

19. Install fanwheel per § 6.220.

20. Install tailcone per § 4.312.

21. Install all engine cowling and tailcone cowling.

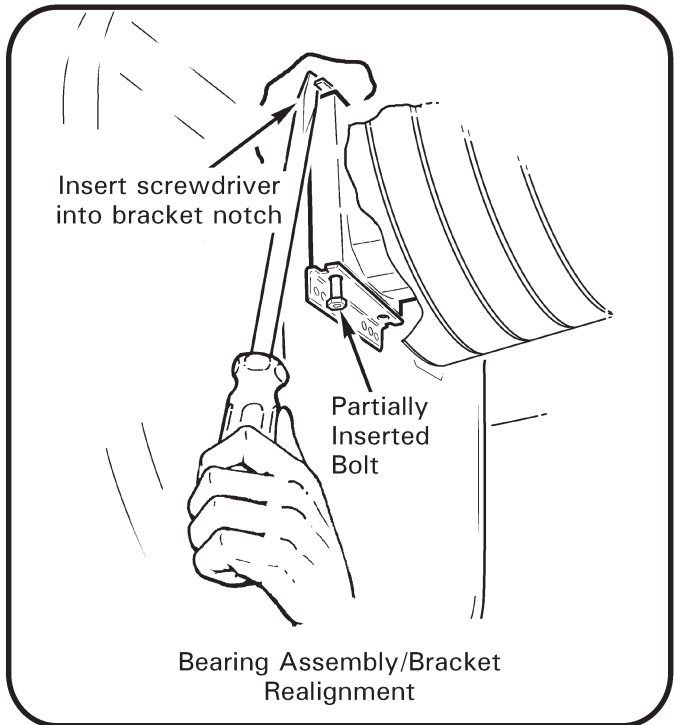
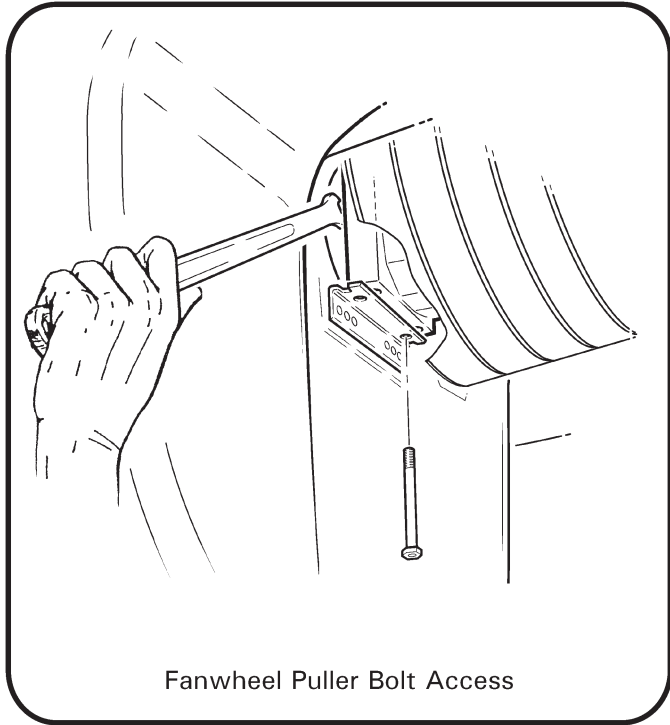

FIGURE 6-3 FANWHEEL HUB BOLT ACCESS

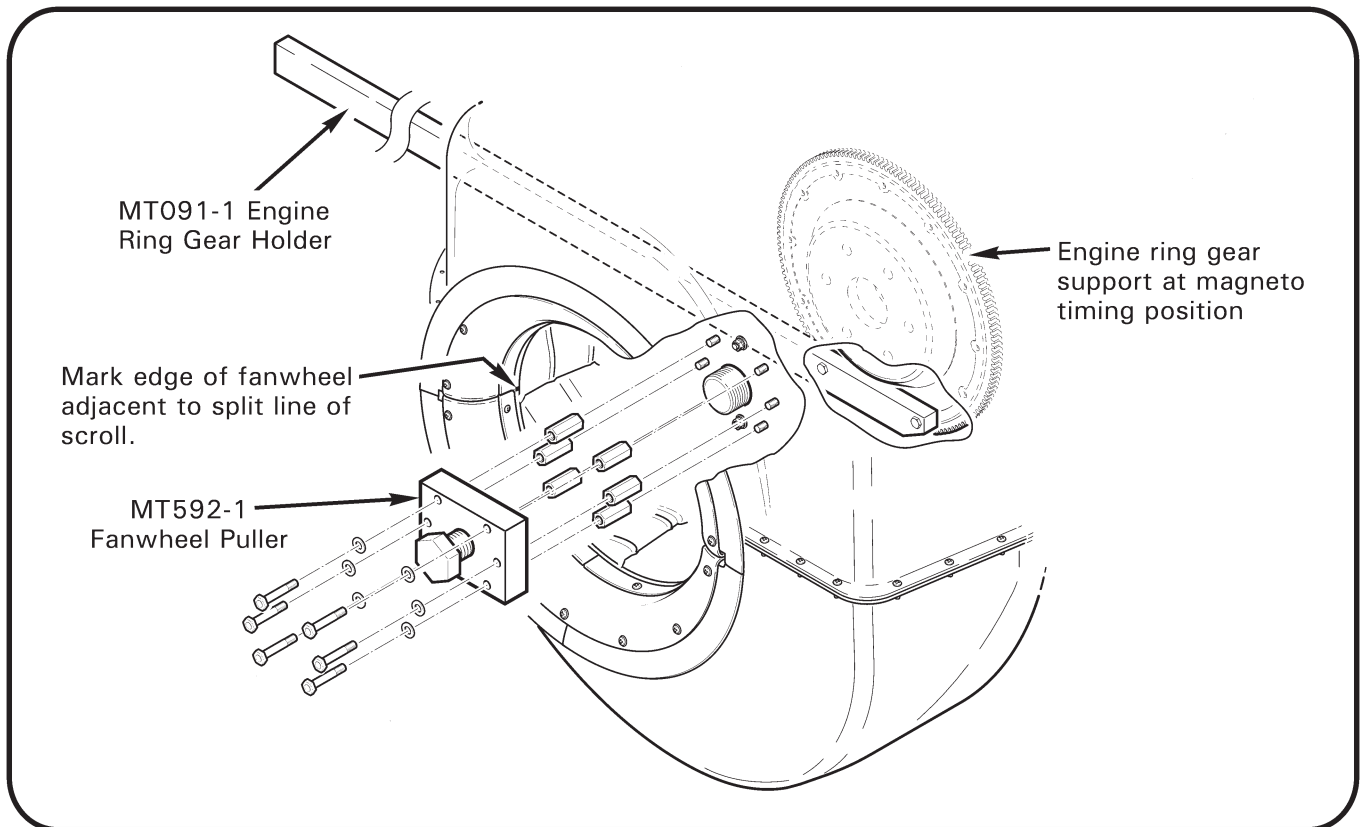

FIGURE 6-4 FANWHEEL PULLER INSTALLATION

6.200 Cooling System

6.210 Fanwheel and Scroll Removal

NOTE

If same fanwheel will be reinstalled then orient starter ring gear support to magneto timing position and mark fanwheel at split line of scroll; this will minimize need for new balance weights. See Figure 6-4.

1. Ensure clutch is fully disengaged. Pull open CLUTCH START circuit breaker and turn battery switch off.
2. Remove engine aft cowling.
3. Remove cooling hoses from lower and upper halves of scroll.
4. Disconnect tail pipe straps from lower scroll. Note shim stack on mounting screws.
5. If installed, disconnect air conditioning condenser from lower scroll and temporarily secure it to a frame.
6. Remove two vertical bolts attaching scroll to C181-3 bearing.
7. Cut safety wire and remove roll pin securing fanwheel retaining nut. Remove retaining nut. Remove washers. Install retaining nut 3 full revolutions (to prevent scroll & unseated fanwheel from dropping).

NOTE

An air- or electric-impact wrench may be used only to remove nut.

8. Install MT092-3 spacers directly on each of 6 long B660-1 bolts (if installed; nuts remain in place). Alternately, use a half-inch open-end wrench to hold fanwheel hub bolt heads and remove 6 of 8 nuts & washers (see Figure 6-3) and replace nuts with MT092-3 spacers.
9. Back out MT592-1 fanwheel puller's center bolt, lubricate bolt tip & threads with A257-9 anti-seize, and attach puller to the MT092-3 spacers (see Figure 6-4).

NOTE

Fanwheel may come off tapered shaft with a loud pop.

10. An air-or electric-impact wrench may be used to tighten fanwheel puller's center bolt & unseat fanwheel. Alternately, securely attach MT091-1 starter ring gear holding tool and immobilize tool so ring gear remains stationary (see Figure 6-4).
11. Tighten fanwheel puller's large center bolt against fanshaft until fanwheel is unseated.
12. Remove fanwheel puller. Remove fanwheel retaining nut, fanwheel, and scroll.
13. If removed, reinstall nuts & washers on fanwheel hub bolts and special torque nuts per § 23-33.

6.220 Fanwheel and Scroll Installation

1. Evaluate drive belts, alternator belt, and C181 bearing condition; replace as required. Clean tapered shaft and fanwheel hub mating surfaces with solvent and dry. Inspect shaft and hub for damage; replace as required.
2. As required, repair scroll per R44 Service Letter SL-61A. Place scroll upper half on fanwheel and install fanwheel on tapered shaft. Secure scroll upper half to engine cooling panels.
3. Using A257-9 anti-seize, coat threaded portion only of C007 shaft and clamping surfaces of MS20002-24 washer, NAS1149F2432P washers (use as many as will fit), and castellated nut. Install hardware with MS20002-24 washer against hub.

NOTE

If installing original fanwheel, ensure starter ring gear support is at magneto timing position and align marks on fanwheel with scroll split line.

4. Secure MT091-1 ring gear holding tool to engine ring gear support and hold stationary. Special torque C182-1 nut per § 23-33 until slot in castellated nut aligns with hole in fanshaft, but do not install spring pin.

NOTE

If slot in castellated nut does not align with hole in fanshaft throughout torque range, remove or add NAS1149F2432P washers under nut.

5. Position lower scroll and insert two AN3-41A bolts through bearing mounting bracket, actuator bearing block, and bearing mounting bracket nut plates on upper scroll. If required, align upper mount bracket nutplate by inserting a screwdriver into notch in bracket. Standard torque bolts per § 23-32 and torque stripe.
6. Install screws, washers, and nuts around scroll perimeter.
7. Verify D229 lip-to-fanwheel inlet clearance is 0.010–0.090 inch. If necessary, adjust lip clearance by elongating lip mounting holes.
8. Connect tail pipe to C173 straps. See § 6.520 for shimming requirements.
9. Connect muffler and MRGB cooling hoses to scroll. Ensure MRGB cooling hoses cross and clear tail rotor push-pull tube thru full range of travel.
10. If applicable, install air conditioning condenser and condenser heat shield on lower scroll.
11. Balance fanwheel per § 6.240.

CAUTION

Fanwheel balance must be checked upon installation; fanwheel imbalance can cause damage.

6.230 (Reserved)

Intentionally Blank

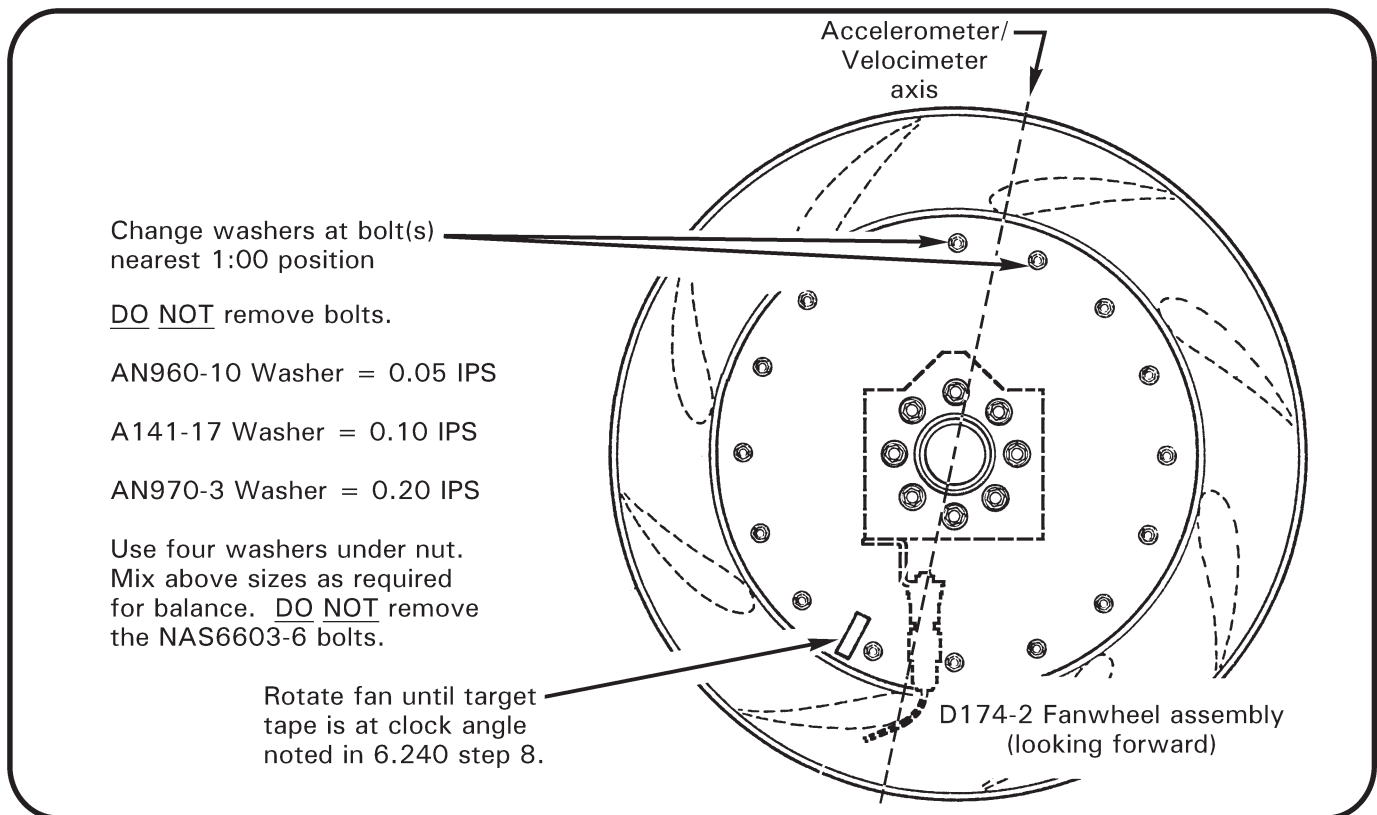
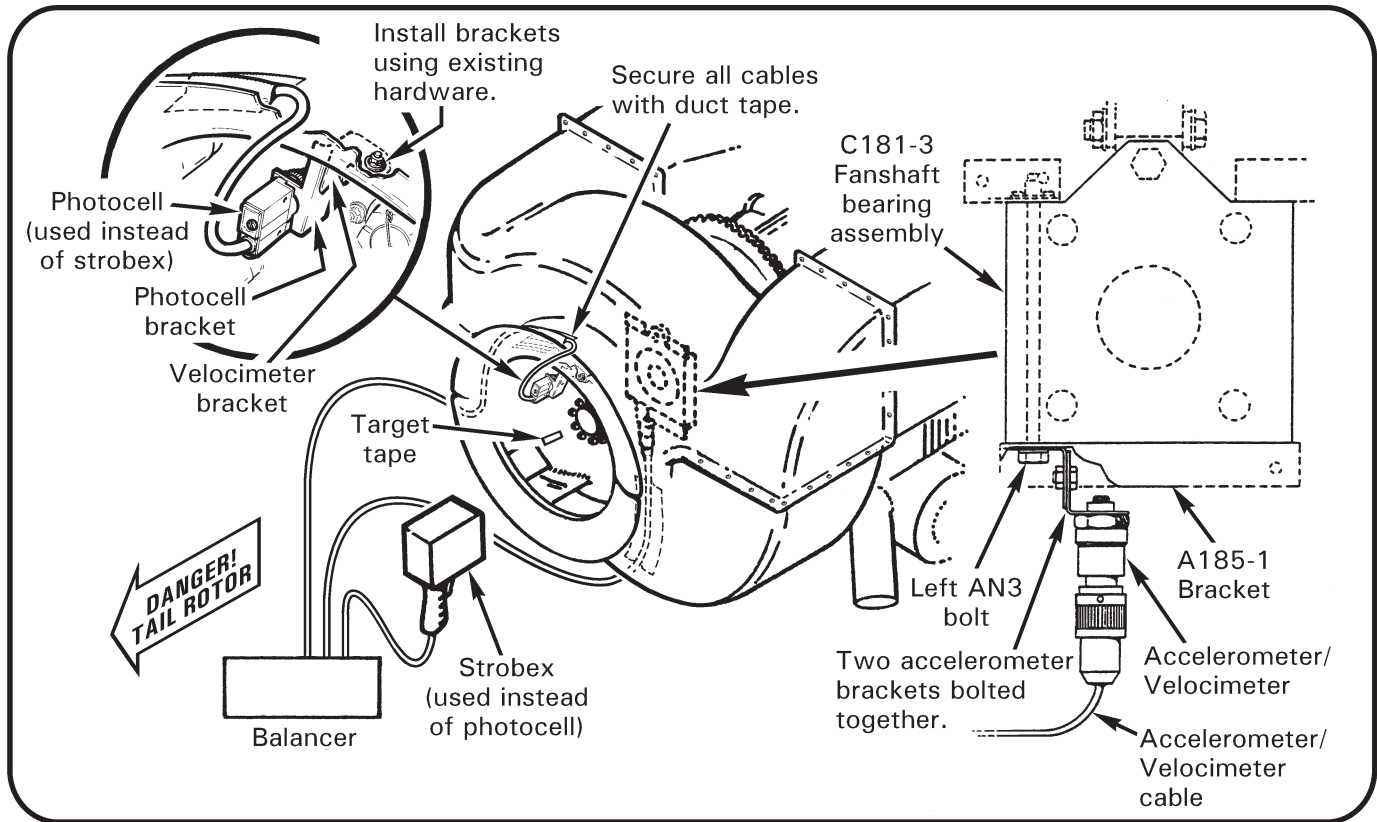

FIGURE 6-5 FAN BALANCING

6.240 Fan Dynamic Balance**NOTE**

When using Micro Vib, Chadwick-Helmuth Model 192- or 8500-series, or equivalent equipment consult the equipment's specific operating instructions. The following instructions pertain to Chadwick-Helmuth Model 8350 and 177-series (Vibrex) equipment.

1. Remove engine aft cowling.
2. Install accelerometer wire on fanshaft bearing per Figure 6-5. Accelerometer should be pointed down. A suitable bracket may be assembled from two accelerometer brackets or may be fabricated.
3. Place a target tape at edge of one fan vane (see Figure 6-5).
4. Set Strobex mode to position B. Set Balance Box RPM range to X10 scale. Set Balance Box RPM dial to 270.
5. Start engine and run helicopter at 102% RPM with rotor system engaged and governor on.

WARNING

Use extreme care near tail rotor.

6. Point Strobex at fanshaft nut and pull trigger. Note clock angle of target tape.
7. Push Tune button on Balance Box. Note change (if any) in clock angle of target tape. While pushing Tune button, adjust RPM dial to bring the target tape back to the clock angle viewed in Step 6. Balance Box is tuned to fan RPM if there is no change in target tape clock angle when Tune button pushed and released.
8. Note clock angle of target tape when Balance Box is tuned.
9. Note vibration reading on IPS meter.
10. Shut engine down.

CAUTION

Ensure ignition switch is off and keys are out of switch whenever fanwheel is moved by hand.

11. After first run-up, secure MT091-1 ring gear holding tool to engine ring gear support and hold stationary. Special torque C182-1 nut per Section 1.330 until spring pin can be installed in shaft. Install spring pin and safety with 0.041-inch diameter stainless steel wire.

NOTE

If spring pin cannot be installed within C182-1 nut's torque range, remove or add NAS1149F2432P washers under nut. Large pliers may be used to squeeze spring pin into position.

6.240 Fan Dynamic Balance (continued)

12. If balance reading is over 0.2 IPS, washers must be exchanged to balance cooling fan. Rotate fanwheel until target tape is in position noted in Step 8. Change AN960-10, A141-17, or AN970-3 washers under nut nearest to the 1:00 position or split required weight change under two nearest nuts (see Figure 6-5). One AN960-10 washer will change balance reading approximately 0.05 IPS. One A141-17 washer equals two AN960-10 washers. One AN970-3 washer equals four AN960-10 washers. Four washers are required under each nut. To access bolt head, remove D229-4 cover on forward side of lower scroll and rotate fan as required. Do not remove the NAS6603-6 bolts or the NAS1149F0316P washers may be dislodged (see Figure 6-5). Torque NAS6603-6 bolt and MS21042L3 nut per Section 1.330. Install D229-4 cover on lower scroll.
13. After washers have been installed, check fan balance reading. Exchange washers until a reading of less than 0.2 IPS is obtained.
14. Remove accelerometer and attaching brackets.
15. Refer to Figure 2-11. Mark fanwheel with torque stripe directly opposite, and aligned with, each end of roll pin.
16. Install engine aft cowling.

6.300 Lubrication System

NOTE

See Section 1 for grade and quantity of oil required. Refer to Lycoming Operator's Manual for adjustment and maintenance of lubrication system.

6.310 Oil Cooler Removal

1. Remove right engine side panel and aft engine cowling.
2. Disconnect the oil lines at the cooler.
3. Remove two screws and nuts holding C636-1 support to cooling shroud.
4. Disconnect mounting bolts and remove oil cooler and support.

6.320 Oil Cooler Installation

1. Install MS20822-8 elbows, if required, using B270-6 sealant and torque to 110 in.-lb plus torque required to align elbows.
2. Install oil cooler and C636-1 Support to engine cooling shroud using four mounting bolts. Torque bolts per Section 1.320.
3. Install two screws and nuts that fasten support to cooling shroud. Torque nuts to 15 in.-lb plus nut drag.
4. Reconnect oil lines and torque tubing nuts per Section 1.330.
5. Install cowling.

6.400 Induction System

6.410 Carburetor Removal

1. Remove right engine side panel.
2. Turn off fuel valve and disconnect fuel line at carburetor. Cap fuel line and carburetor inlet port.
3. Disconnect air intake and carburetor heat ducts from air box.
4. Disconnect throttle linkage from throttle arm, mixture control cable from carburetor and carburetor heat control cable from air box and slider valve.
5. Disconnect carburetor air temperature probe at quick-disconnect plug located approximately four inches from probe.
6. Remove palnuts and nuts securing carburetor to oil sump and remove carburetor and air box assembly.

6.420 Carburetor Air Box Removal

1. Remove four long bolts securing air filter cover. Open cover and remove air filter.
2. Clip safety wire securing four air box-to-carburetor attach bolts and remove bolts, air box and gasket.

6.430 Carburetor Air Box Installation

1. Install air box and gasket to carburetor with four attach bolts.
2. Torque four attach bolts per Section 1.330 and safety with 0.032 inch safety wire.
3. Reinstall air filter, close cover and secure with four long bolts.

NOTE

Tighten nuts on long attach bolts until 2-4 threads protrude through nut and cover is uniformly sealed. Overtightening of nuts can cause distortion of cover and leakage of air box seal.

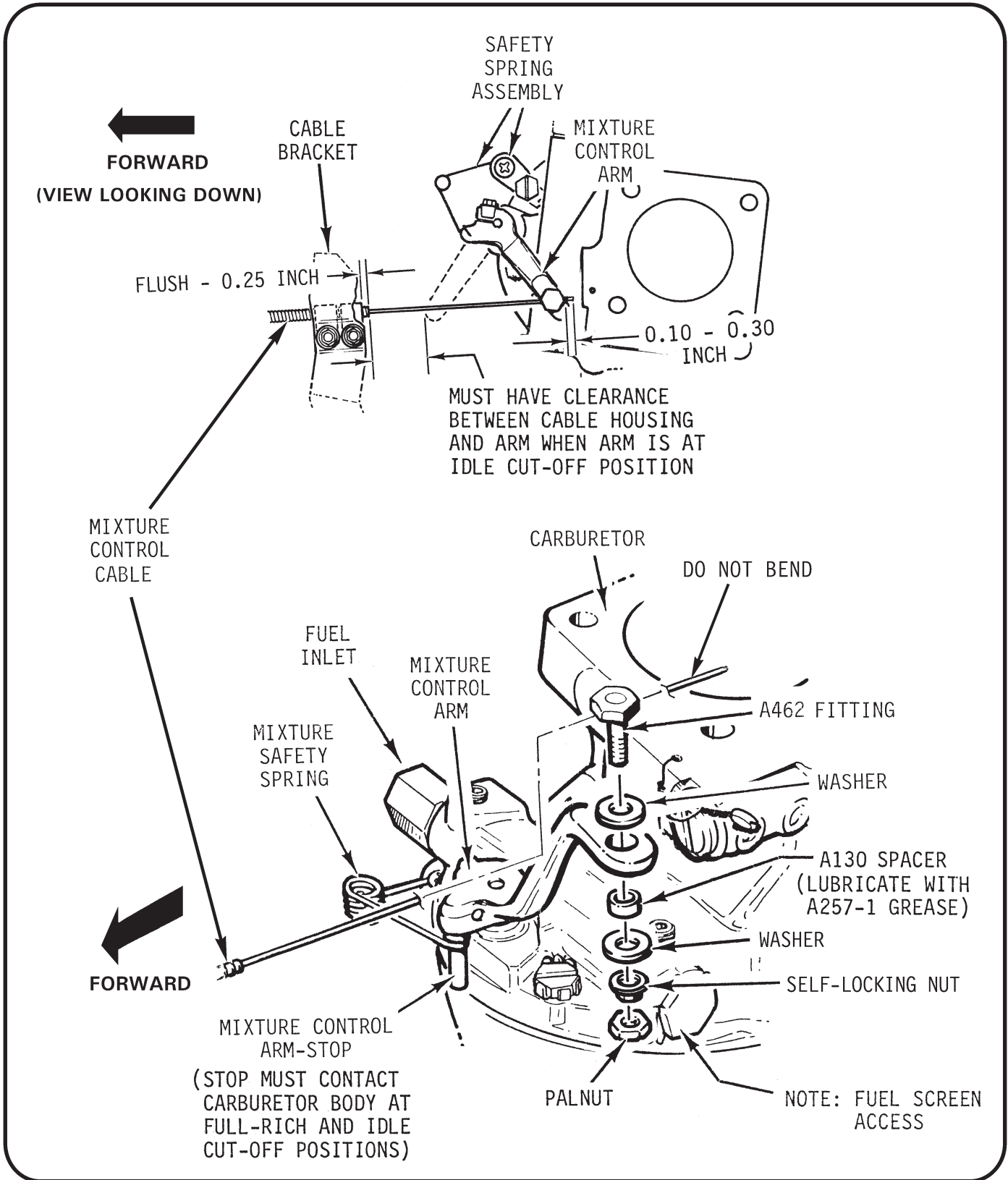

FIGURE 6-6 O-540 MIXTURE CONTROL INSTALLATION

6.440 Carburetor Installation

1. Install air box per Section 6.430.
2. Using new gasket, install carburetor on oil sump mounting studs with throttle arm to ship's left. Torque mounting nuts per Section 1.330 and install palnuts.
3. Connect throttle linkage to throttle arm. Adjust throttle correlation rigging per Section 10.150 and torque per Section 1.320.
4. Connect mixture control cable to carburetor (see Figure 6-6) and carb heat control to air box slider valve. Rig each control for 0.03-0.10 inch clearance under knobs when fully depressed. Verify full travel of mixture arm and carburetor heat slider valve.
5. Connect carburetor air temperature probe and secure connector to carburetor with ty-rap.
6. Connect fuel hose to carburetor and torque per Section 1.330.
7. Connect air intake and carburetor heat hoses to air box.
8. Install engine cowling(s).
9. Comply with Section 2.210, steps 15 & 16.

6.450 Carburetor Heat Scoop Removal

1. Remove engine right cowling.
2. Disconnect hose from air box to carb heat scoop.
3. Loosen clamps and remove scoop.

6.460 Carburetor Heat Scoop Installation

1. Position scoop on exhaust manifold and tighten mounting clamps.
2. Connect hose from air box to scoop.
3. Inspect scoop for 0.1-inch minimum clearance in all directions; adjust as required. Torque mounting clamp screws per Section 1.320.
4. Install engine cowling.

6.470 Fuel Injection Air Box Removal

1. Remove engine right cowling.
2. Remove air intake hose.
3. Cover fuel control air intake.
4. Remove four screws and large area washers atop of, and securing air box to, horizontal firewall.
5. Remove air box.

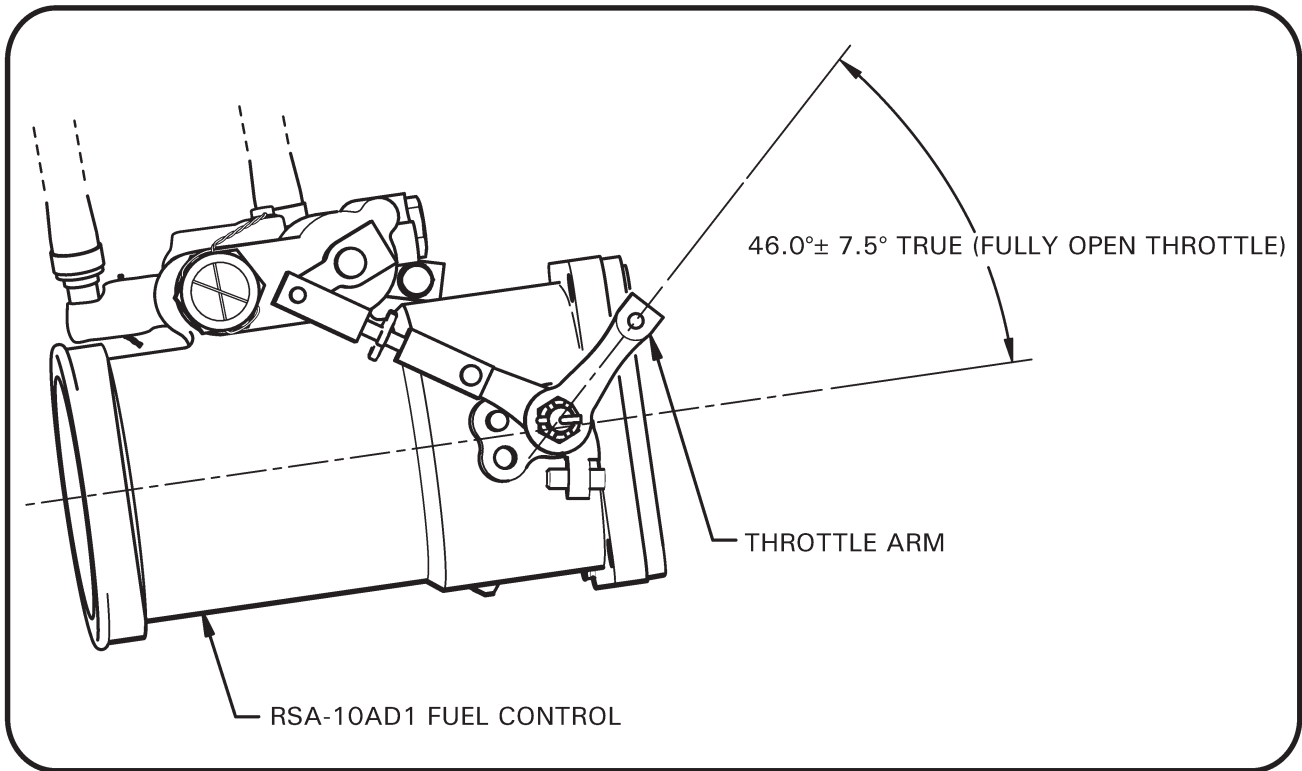

FIGURE 6-7 IO-540 THROTTLE ARM ADJUSTMENT

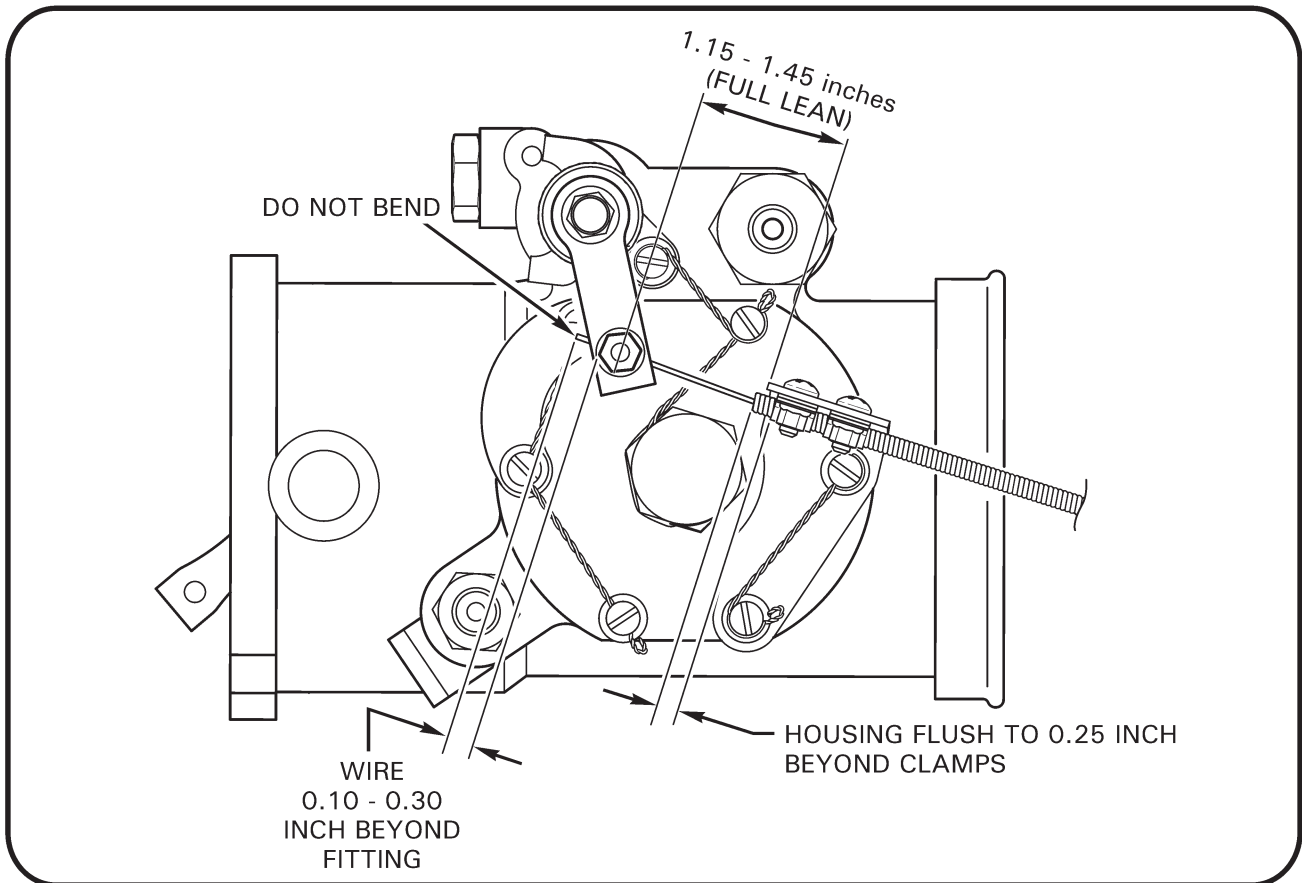

FIGURE 6-8 IO-540 MIXTURE CABLE INSTALLATION

6.480 Fuel Injection Air Box Installation

1. With intake pointing outboard, position air box below forward, right side of horizontal firewall and secure to firewall with four screws.
2. Remove fuel control air intake protective cover, if installed, and install air intake hose between air box and fuel control.
3. Verify clearance between air box, intake hose and adjacent components; adjust component position as required for clearance.
4. Install engine cowling.

6.490 Fuel Control Removal

1. Turn fuel shut-off valve off.
2. Remove right cowling.
3. Remove air intake hose.
4. Disconnect fuel control inlet tee from fuel control inlet reducer. Install protective caps on all open fuel passages.
5. Disconnect and cap fuel hose from fuel control outlet.
6. Disconnect push-pull tube from bellcrank attached to fuel control mounting flange.
7. Disconnect mixture control cable from fuel control.
8. Loosen lower, aft bolt securing fuel control to intake manifold. Remove three remaining bolts and remove fuel control with attached link and bellcrank.
9. Remove old gasket from intake manifold inlet. Cover inlet if not immediately replacing fuel control.
10. Compare fittings on removed fuel control with replacement fuel control. Transfer fittings as required and torque per Section 1.330.

6.495 Fuel Control Installation

1. Compare fittings on removed fuel control with replacement fuel control. Transfer fittings as required and torque per Section 1.330.
2. Remove temporary shipping safety wire from mixture and throttle arms.
3. Verify correct full-open throttle arm angle per Figure 6-7 and full-lean mixture arm distance per Figure 6-8. Adjust as required.
4. Remove protective caps from fuel inlet and outlet. Drain all fluid.
5. Using new gasket and with fuel inlet pointing up, install fuel control on intake manifold flange with longer bolt thru bellcrank in forward, upper hole.

6.495 Fuel Control Installation (continued)

6. Connect fuel inlet tee to fuel control inlet reducer. Torque per Section 1.330 and torque stripe.
7. Connect throttle push-pull tube. Verify full travel (collective must be raised slightly to achieve full-open throttle).
8. Refer to Figure 6-8. Connect mixture cable housing to bracket with housing flush-to-0.25 inch extended beyond clamps. Connect mixture control cable inner wire to mixture control arm. Ensure A130 spacer lubricated with A257-1 grease. Verify full travel and 0.03-0.10 inch clearance under mixture control knob when full rich. Mixture control inner wire should protrude 0.10-0.30 inch beyond A462 fitting securing wire to mixture control arm and control wire. If wire cannot rotate relative to mixture arm the A130 spacer in fitting may be missing or damaged; replace as required.
9. Install air intake hose between air box and fuel control.
10. Electrically ground the helicopter.
11. Place a clean container beneath fuel control outlet and connect a ground wire between container and helicopter.
12. Pull CLUTCH-START circuit breaker.
13. Turn fuel shut-off valve on.
14. Turn battery switch on. Open throttle. Turn ignition key to PRIME position and hold until fluid exiting fuel control is the same color as avgas (fuel control is typically shipped with non-flammable oily preservative). Continue flushing fuel control until avgas exiting fuel control no longer exhibits oily smell and feel.
15. Close throttle and turn battery switch off.
16. Connect fuel control outlet hose. Torque per Section 1.330 and torque stripe.
17. Turn battery switch on. Turn ignition key to PRIME position and hold until AUX FUEL PUMP light extinguishes. Turn ignition key off. Inspect fuel control and attached fuel connections and verify no leakage.
18. Remove grounding wire(s).
19. Perform preflight, start engine, and run up using R44 POH checklist.
20. Set idle rpm to 58-62% rpm with engine warm and clutch engaged.
21. Shut down engine using R44 POH checklist.
22. Disconnect fuel control outlet hose, connect test hose if desired, and measure fuel flow rate at fuel control outlet with mixture full rich, throttle at idle, and electric fuel pump on (ignition key at PRIME position).

6.495 Fuel Control Installation (continued)

23. Adjust idle mixture as required to obtain 16–18 pounds/hour fuel flow (170–190 cc/minute). Clockwise rotation of idle mixture adjustment wheel (viewed from aircraft right side) enriches mixture. Re-check idle rpm after mixture adjustment and repeat as required until both rpm and mixture are within limits. With rpm and mixture set, verify smooth acceleration from idle to 102% rpm with no engine hesitation or smoke from tailpipe. Also verify smooth needle split from 102% to idle with no engine roughness or erratic rpm indications and acceptable idle quality. Note that 16–18 pounds/hour fuel flow should produce acceptable idle quality and off-idle throttle performance under sea-level standard conditions. Richer mixtures may be required for cold temperature operation and leaner mixtures may be required for hot/high altitude operation. Deviate from 16–18 pounds/hour recommendation as required for acceptable idle quality and off-idle throttle performance (smooth accelerations and needle splits).
24. Adjust throttle correlation rigging per § 10.150.
25. Install right cowling.

6.500 Exhaust System

6.510 Exhaust System Removal

1. Remove left and right side cowlings, and remove aft cowling assembly.
2. As required, loosen clamps securing shields to inlets and tail pipe and remove shields.
3. **O-540 engine:** Loosen clamps securing carburetor heat scoop to riser/collector.
4. Remove hardware securing C173 straps to tail pipe.
5. Loosen clamps securing hoses to muffler shroud.
6. Supporting C169 muffler assembly, remove nuts and washers securing risers to cylinders and remove muffler. Discard gaskets.
7. As required, remove hardware securing bead clamps to risers/collectors, remove clamps, and remove and discard A701-10 stainless-steel tape if installed.

6.520 Exhaust System Installation

1. Install new gaskets and install hardware securing C169 muffler assembly or exhaust risers/collectors (if disassembled from C169 muffler assembly) to cylinders. Draw up (12) 21FKF-518 nuts evenly prior to torquing; special torque nuts per § 23-33.
2. If exhaust risers/collectors were disassembled from C169 muffler assembly, position muffler on risers/collectors installed in step 1. Wrap joint under bead clamps with new A701-10 stainless-steel tape as required, and install hardware securing bead clamps. Standard torque bead clamp bolts per § 23-32. Verify security.

CAUTION
 Ensure bead clamp bolt flanges are oriented so any leakage is directed away from ignition components and structure.

3. Install clamps securing hoses to muffler shroud. Verify security.
4. **O-540 engine:** Tighten clamps securing carburetor heat scoop to riser/collector. Verify security.
5. If removed, tighten clamps securing heat shields to inlets and tail pipe. Verify security.
6. Install hardware securing C173 straps to tail pipe. Shim between tail pipe ears and straps using NAS1149F0332P washers (1 minimum, 3 maximum at each fastener) to create a 0.02–0.08 inch forward preload. Verify security.
7. Install aft cowling assembly, and install left and right side cowlings.
8. Revise Weight and Balance Record in applicable Pilot’s Operating Handbook (POH) Section 6 to incorporate the following data as required:

	Weight	Long. Arm	Long. Moment	Lat. Arm	Lat. Moment
C169-1 Muffler Assembly	17.6 lb	124.4 in.	2189.4 in.-lb	-1.0 in.	-17.6 in.-lb
C169-31 Muffler Assembly	17.6 lb	124.2 in.	2185.9 in.-lb	-1.2 in.	-21.1 in.-lb
C169-35 Muffler Assembly	18.6 lb	124.6 in.	2317.6 in.-lb	-0.9 in.	-16.7 in.-lb
C169-37 Muffler Assembly	18.6 lb	124.4 in.	2313.8 in.-lb	-1.1 in.	-20.5 in.-lb

6.600 Troubleshooting

6.610 Low-Power Checklist

When low engine power output is suspected, use the following checklist to verify:

1. Aircraft gross weight is not exceeded. Weigh aircraft if it was not weighed at last overhaul.
2. Engine oil pressure, oil temperature, and CHT are within limits.
3. MAP gage indicates ambient pressure (engine off).
4. Proper grade of fuel per Pilot's Operating Handbook.
5. Main rotor blades are clean and smooth (no rough paint).
6. Exhaust is unobstructed.
7. Main rotor blade trim tabs are not excessively bent.
8. If equipped, verify carburetor heat valve closes fully in off position.
9. Induction system is unobstructed. Air filter and both inlet hoses (ambient and carburetor heat) are clean, undamaged, unobstructed, and do not collapse in flight. Carburetor-to-engine gasket is correct size.
10. Fuel injector nozzles are unobstructed (IO-540 only). Clean nozzles per Lycoming Service Instruction 1275C.
11. Engine tachometer indication is correct. Verify with digital tachometer (such as found in newer dynamic balancing equipment) or similar equipment.
12. Oil screens or filter do not exhibit metallic debris consistent with internal engine damage.
13. Proper cylinder compression (both leakage and direct) per Lycoming recommendations.
14. Mixture neither excessively lean nor rich. Compare fuel flow. Verify fuel filter cleanliness, check spark plug indications, check carburetor throttle body-to-float bowl screw security per Lycoming SB 366.
15. Proper spark plug type and condition.
16. Proper magneto-to-engine timing. Verify engine-left (helicopter-right) magneto is not operating in retard mode when ignition switch is in BOTH position (disconnect retard terminal after starting engine and compare hover MAP indications; lesser hover MAP with retard terminal disconnected indicates magneto was operating retarded).
17. Proper fuel flow and unobstructed carburetor/fuel control inlet screen. Perform fuel-flow check per Section 12.
18. If primer-equipped carbureted engine, verify fuel is not leaking past primer pump (ensure primer pump is locked) and air is not leaking past fittings in cylinder head.

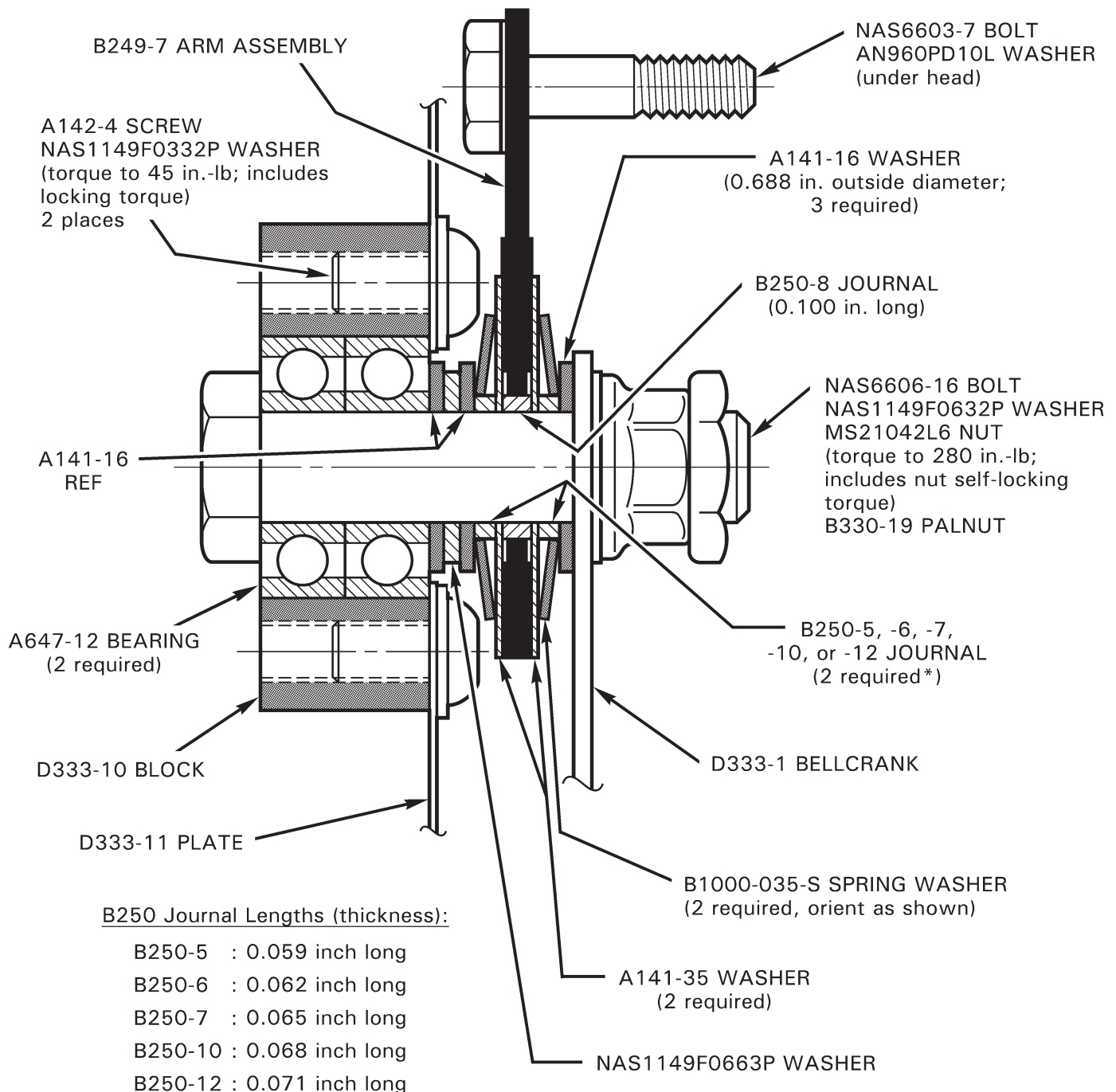

*Install B250-5, -6, -7, -10, or -12 journals as required to produce a rotational friction of 10-12 inch-pounds. Journal dash numbers may be mixed. After adjustment, clamp long side of D333-11 plate in padded vise with B249-7 arm assembly contacting vise jaws while providing rotational clearance for D333-1 bellcrank; measure rotational friction by rotating bolt head with dial-indicating torque wrench.

FIGURE 6-9 D334 BELLCRANK - CARB HEAT ASSIST FRICTION ADJUSTMENT

6.610 Low-Power Checklist (continued)

19. Carburetor or fuel control throttle lever contacts full-throttle stop (collective must be raised slightly).
20. Carburetor or fuel control mixture arm contacts stop when mixture control is in full-rich position and mixture arm does not exhibit springback at extremes of travel when disconnected from control cable/safety spring (due to internal binding).
21. No induction/MAP system leaks. To check MAP system, disconnect MAP line at cylinder head fitting and apply suction with syringe until MAP gage indicates 10 inches Hg. Monitor gage for one minute; indication should rise no more than 1 inch Hg. Verify carburetor throttle shaft bushings are not worn; check both axial and radial clearances. Intake leaks can also occur due to loose intake pipe connections in oil sump and/or cracked sump runner tubes. On fuel-injected engines, verify intake manifold drain ("sniffle") valve does not leak ambient air into intake manifold.
22. Proper exhaust valve guide clearance per Lycoming SB388 (latest revision).
23. Proper dry-tappet clearance per Lycoming Overhaul Manual.
24. With lifters pumped up (valve lash removed), each intake valve should exhibit equal travel during opening when measured with a dial indicator. Similarly, each exhaust valve should exhibit equal travel during opening. Unequal travel indicates damaged cam lobe(s).
25. Proper magneto internal timing.
26. Carburetor float bowl fuel level correct.
27. Cylinder head intake port has radiused edge where inlet airflow turns 90 degrees toward valve. If no radius exists, contact Lycoming Technical Support.
28. Proper crankshaft-to-camshaft timing: As #1 piston passes TDC on compression stroke, the #2 intake valve should open while the #2 exhaust valve closes (valve overlap position).
29. If engine exhibits low-power immediately after overhaul, verify correct 8.5:1 compression ratio piston P/N 75089 has been installed (instead of 7.0:1 low compression piston P/N 75413).

Intentionally Blank

CHAPTER 7**DRIVE TRAIN**

<u>Section</u>	<u>Title</u>	<u>Page</u>
7.000	Drive Train	7.1
7.001	Introduction	7.1
7.002	Description	7.1
7.100	Main Rotor Gearbox	7.1
7.110	Main Rotor Gearbox Removal	7.1
7.120	Main Rotor Gearbox Installation	7.4
7.130	Leveling Main Rotor Gearbox	7.5
7.140	C908-1 Yoke Replacement	7.6
7.141	Setting Hall Effect Sender Gap	7.6
7.150	Replacement of Main Rotor Gearbox Pinion Seal	7.6
7.155	Main Rotor Gearbox Sump O-Ring Replacement Procedure	7.8
7.160	Main Rotor Gearbox Overtemp Inspection	7.8A
7.170	Main Rotor Gearbox Chip Light Indicator	7.8A
7.200	Clutch Assembly	7.9
7.210	Clutch Assembly Lubricant Inspection and Servicing	7.9B
7.211	C184 Bearing Assembly Removal	7.14A
7.212	C184 Bearing Assembly Installation	7.15
7.213	Clutch Assembly Seals Replacement	7.16
7.220	[Reserved]	7.17
7.230	Clutch Sheave Alignment	7.23
7.240	Clutch Shaft Angle	7.23
7.250	[Reserved]	7.23
7.260	C907 Yoke Removal and Installation	7.25
7.270	C195 Yoke Removal and Installation	7.26
7.280	V-Belts	7.27
7.281	V-Belt Removal	7.27
7.282	V-Belt Installation	7.27
7.283	Belt Tension	7.30
7.290	C007 Fanshaft and Bearing Assembly, Starter Ring Gear Support, Lower Sheave, and Alternator Belt Replacement	7.30
7.291	Removal	7.30
7.292	Installation	7.30
7.300	Tail Rotor Drive Shaft	7.31
7.310	Tail Rotor Drive Shaft Removal	7.31

CHAPTER 7

DRIVE TRAIN (Continued)

<u>Section</u>	<u>Title</u>	<u>Page</u>
7.320	Tail Rotor Drive Shaft Installation	7.31
7.321	Adjustment of Damper Friction	7.33
7.330	Intermediate Flex Plate Installation and Shimming	7.36
7.340	Checking Tail Rotor Drive Shaft Runout	7.37
7.350	Two-Piece Tail Rotor Drive Shaft	7.38
7.400	Tail Rotor Gearbox	7.41
7.410	Tail Rotor Gearbox Removal	7.41
7.420	Tail Rotor Gearbox Installation	7.41
7.430	Tail Rotor Gearbox Chip Indicator	7.41
7.440	Tail Rotor Gearbox Output Shaft Seal Replacement	7.41
7.450	Tail Rotor Gearbox Input Shaft Seal Replacement	7.44
7.500	Actuator Assembly	7.46
7.510	Actuator Removal	7.46
7.520	Actuator Installation	7.46
7.530	Actuator Gearmotor Replacement	7.47
7.540	Adjustment of Actuator	7.49
7.550	Switch and Fuse Replacement	7.49
7.551	Switch Replacement	7.49
7.552	Fuse Replacement	7.51
7.600	Rotor Brake	7.51
7.610	Rotor Brake Removal	7.51
7.620	Rotor Brake Installation	7.51
7.630	Rotor Brake Pad Replacement	7.51

CHAPTER 7

DRIVE TRAIN

7.000 Drive Train7.001 Introduction

This section contains the procedures for removal, installation, replacement, and maintenance of the drive train components.

7.002 Description (see Figure 7-1)

A V-belt sheave is bolted directly to the crankshaft of the engine; four double V-belts transmit power to the upper sheave, which has an overrunning clutch in its hub. The clutch shaft transmits power forward to the main rotor and aft to the tail rotor. Flexible couplings are located at the input to the main gearbox and at each end of the long tail rotor drive shaft. The main rotor gearbox contains a single-stage spiral-bevel gear set, which is splash-lubricated. The long tail rotor shaft has no hanger bearings but has a lightly-loaded damper bearing. The tail rotor gearbox also contains a splash-lubricated spiral bevel gear set. The tail rotor gearbox input and output shafts are both made of stainless steel to prevent corrosion. The other shafts throughout the drive system are made of alloy steel.

7.100 Main Rotor Gearbox7.110 Main Rotor Gearbox Removal

- a) Remove the C706-1 tailcone cowling, both engine side panels, and the aft engine cowling.
- b) Remove the mast fairing per Section 4.142. Remove the middle and lower mast fairing ribs from the mast tube.
- c) Remove the main rotor per Section 9.111.
- d) Disconnect the rotor brake cable pulleys on the arm and aux tank. Remove the cable housing clamp on the aux tank channel.

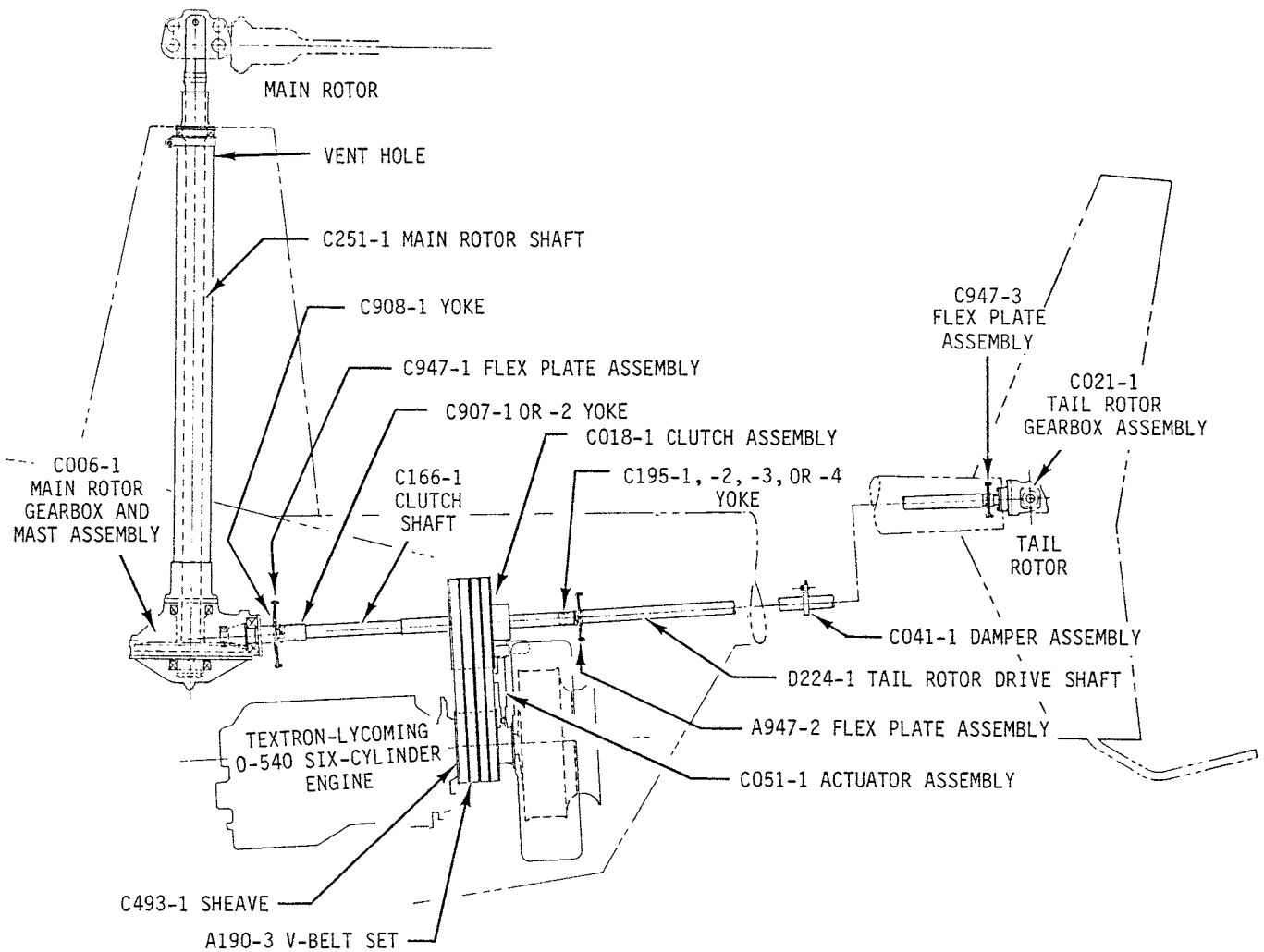

FIGURE 7-1 DRIVE SYSTEM

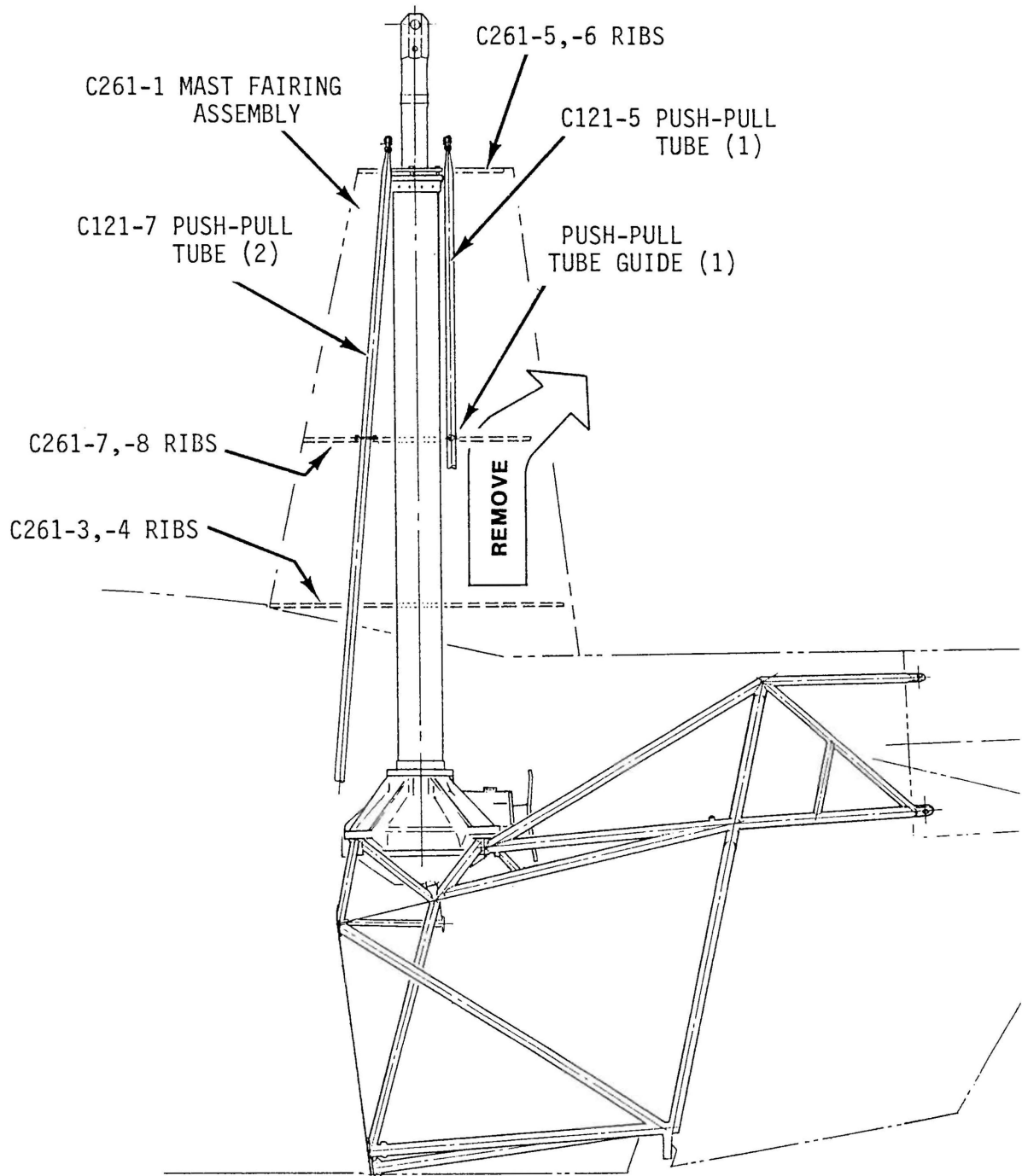

FIGURE 7-2 MAIN ROTOR GEARBOX REMOVAL

7.110 Main Rotor Gearbox Removal (cont'd)

- e) Remove the main and auxiliary fuel tanks per Section 12.110. Mark all electrical connections for reinstallation.
- f) Disconnect the jackshaft (C337-1) from the forward and aft push-pull tubes and the support struts.
- g) Remove the jackshaft support struts (see Section 8.300).
- h) Disconnect forward flex plate from gearbox yoke and note the washer stack up on each bolt.
- i) Disconnect the chip detector, Hall Effect sender, overtemp sender leads, and ground wire. Tag wires for reassembly.
- j) Remove the gearbox left and right cooling hoses and nozzle.
- k) Remove the four main rotor gearbox mounting bolts. Carefully lift the gearbox up to clear the forward push-pull tubes and remove (see Figure 7-2).
 - 1) It is recommended that the transmission be hoisted using the MT527-1 helicopter lifting fixture.

CAUTION

Leveling shims may be installed between the gearbox mounts and the frame mounting pads. These should remain attached or mark mounting pads with shim thickness for reinstallation.

- l) Remove the droop stops and disconnect the lower scissors at the mast. Slide the swashplate assembly off the slider tube.

7.120 Main Rotor Gearbox Installation**CAUTION**

Prior to operation of a new, overhauled or repaired gearbox, 6 ounces of A257-2 gear oil must be injected into the vent hole (see Figure 7-1) on the top aft side of the mast tube. Fill gearbox with oil to the level indicated on the sight glass decal. The gearbox must remain vertical during and after filling.

7.120 Main Rotor Gearbox Installation (cont'd)

1. Level MRGB mounting pads by installing original shims. If original shim thickness is unknown, level mounting pads per Section 7.130.
2. Verify two C796-3 spacers are the same thickness and install one C796-3 spacer on each aft mounting pad atop any shim(s).
3. Remove foreign objects and prepare area for gearbox installation. Assistance is desirable to help position gearbox. Position MRGB on mounting pads.
4. Install MRGB mounting hardware per Figure 7-2A. Orient A650 fitting tabs laterally per Figure 8-9, special torque per Section 1.330, and torque stripe per Figure 2-1.
5. Connect forward flex plate, using previously recorded shim washer positions. Standard torque fasteners per Section 1.320.
6. Install jackshaft support struts and jackshaft (see Section 8.300).
7. Connect main rotor gearbox cooling hoses and nozzle.
8. Install fuel tanks per Sections 12.130 and 12.140.
9. Connect electrical leads to fuel tanks and main rotor gearbox. Reinstall rotor brake upper pulley and cable and connect pulley to arm. Install rotor brake cable clamp to auxiliary tank channel. Position cable end fitting on outboard side of pulley on aux tank.
10. Install main rotor per Section 9.000.
11. Install mast fairing and connect pitot tube.
12. Check clutch sheave alignment per Section 7.230.
13. Check intermediate flex plate shimming per Section 7.330.
14. Install all cowling.

7.130 Leveling Main Rotor Gearbox

Level main rotor gearbox mounting pads laterally to landing gear aft cross tube and longitudinally at $3.8^\circ \pm 0.2^\circ$ angle to C046-6 tube (ref Figure 4-2). Use A796-1 shims on forward pads and C796-2 shims on aft pads, maximum 3 shims per pad (shims are 0.020 inch thick).

7.140 C908-1 Yoke Replacement

Yoke Removal

1. Remove clutch per section 7.210 or remove forward flex plate and let forward end of clutch shaft rest on firewall per Figure 7-8. Place a wood block between horizontal firewall and yoke flange to prevent yoke from rotating, or engage rotor brake.
2. Remove cotter pin, nut, and C141-10 washer from main rotor gearbox pinion shaft.
3. Slide yoke off gearbox pinion shaft.

Yoke Installation

1. Ensure yoke and gearbox splines are clean and undamaged. Install C908-1 yoke on main rotor gearbox pinion shaft. Install C141-10 washer and AN320-8 castellated nut.
2. Support yoke for torquing by placing a wood block between yoke flange and horizontal firewall. Special torque AN320-8 nut per Section 1.330 and install cotter pin. Remove block.

CAUTION

Check Hall Effect sender-to-yoke magnet gap per Section 7.141 before run-up or turning blades.

3. Install clutch assembly and/or forward flex plate per Section 7.220.

7.141 Setting Hall Effect Sender Gap

If Hall Effect Sender gap is not 0.030 ± 0.010 inch, loosen jam nuts on sender and adjust gap. Check gaps between both yoke magnets at both senders.

7.150 Replacement of Main Rotor Gearbox Pinion Seal (see Figure 7-2B)

- a. Disconnect A947-2 intermediate flex plate at tail rotor drive shaft. Mark flex plate and fasteners with a grease pencil for reinstallation.
- b. Disconnect C947-1 forward flex plate.
- c. Rest forward end of clutch on firewall. Remove the C908-1 yoke from pinion shaft per Section 7.140.
- d. Cut safety wire and remove rotor brake assembly per Section 7.610.
- e. Remove Hall Effect sender bracket and gearbox overtemp sender bracket.
- f. Carefully slide pinion bearing end cover off pinion shaft.

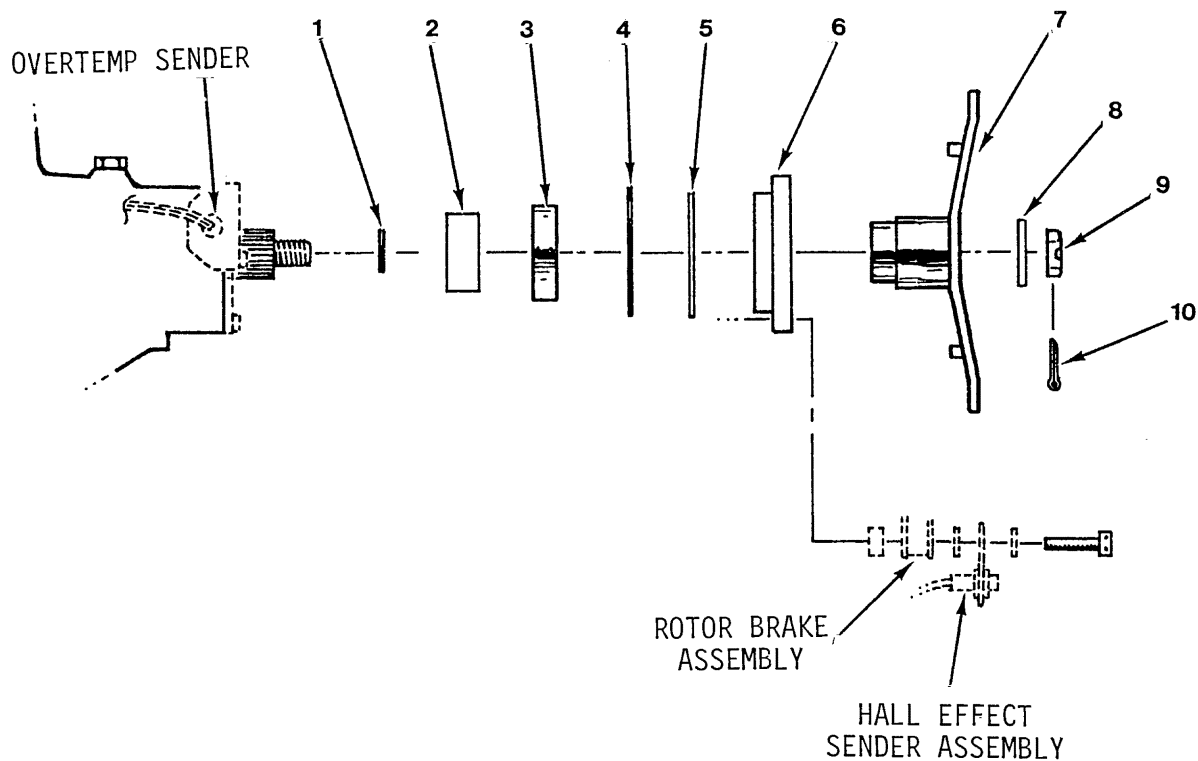

<u>NUMBER</u>	<u>PART NO.</u>	<u>DESCRIPTION</u>
1	C215-029	"O"-RING
2	C266-1	SPACER
3	C966-3	SEAL
4	C215-156	"O"-RING
5	C117	SHIM
6	C270-1	END COVER
7	C908-1	YOKE ASSEMBLY
8	C141-10	WASHER
9	AN320-8	NUT
10	MS25665-210	COTTER PIN

FIGURE 7-2B MAIN ROTOR GEARBOX PINION SEAL REPLACEMENT

7.150 Replacement of Main Rotor Gearbox Pinion Seal (cont'd)**CAUTION**

Do not remove shims under pinion bearing end cover as they control bearing preload and gear backlash.

- g. Press seal out of bearing end cover and press in new seal until it seats.

NOTE

Open face of seal must point toward gearbox.

- h. Install bearing end cover over pinion shaft. Place Hall Effect sender bracket and overtemp sender bracket on cover and install rotor brake assembly per Section 7.620.
- i. Torque screws per Section 1.330 and safety with 0.032 inch diameter safety wire.
- j. Check Hall Effect sender gap per Section 7.141.

7.155 MRGB Sump O-Ring Replacement Procedure

- a. Remove MRGB per Section 7.110.
- b. Check and record gear backlash at and tangential to a gear tooth, accessible via sight gage or filler plug hole.
- c. Carefully note and record position of each fastener, washer and shim stack-up at all C263-1 sump-to-C264-1 housing attach points (an equal amount of shims is installed between sump and housing at each attach point). Also note location of ground wires and C747-1 baffle attach points. Remove, identify and retain fasteners, washers and shims.
- d. Remove sump and o-ring.
- e. Prelubricate new C215-279 o-ring with A257-2 oil and install on sump. Ensure o-ring is not twisted in sump groove.
- f. Carefully assemble sump, baffle and ground wires to housing and secure finger-tight with fasteners, washers and shims installed in exactly the same positions recorded in step c.
- g. Prior to torquing fasteners, position those shims used on NAS1352 series (internal-wrenching) screws against C264-1 housing to prevent shims from interfering with bolt threads and deforming.
- h. Torque bolts per Section 1.320. Torque NAS1352 screws per Section 1.330 and safety wire per MS33540.

7.155 MRGB Sump O-Ring Replacement Procedure (continued)

- i) Check gear backlash exactly as performed in step b. Backlash should be within 0.001 inch of value recorded in step b.
- j) Install MRGB per Section 7.120.

7.160 Main Rotor Gearbox Overtemp Inspection

1. Perform the following if MR TEMP warning light illuminates, and gearbox Telatemp indicates abnormally high operating temperature:
 - a. Inspect gearbox cooling duct for obstructions and conditions. Clear obstructions or replace duct as required.
 - b. Remove chip detector and inspect for chips. Return gearbox to RHC if chips are found.
 - c. Drain gearbox oil and remove sight gage and filler plug. Observe gear tooth surfaces thru filler plug and sight gage holes while rotating gearbox pinion and inspect for damage. Return gearbox to RHC if damage is detected or if gearbox does not rotate smoothly. If no damage is noted, refill gearbox.
 - d. Replace Telatemp. Ensure old Telatemp adhesive is removed and new Telatemp makes good contact with gearbox.
 - e. If gearbox overtemp indications continue, return gearbox to RHC.
2. If MR TEMP warning light illuminates but Telatemp indicates normal operating temperature, replace gearbox overtemp sender and perform steps 1a, 1b, and 1e.
3. If Telatemp indicates 240°F/116°C but MR TEMP warning light does not illuminate, test MR TEMP warning circuit and perform steps 1a, 1b, 1d, and 1e.

NOTE

Light illuminates at $240 \pm 5^{\circ}\text{F}$.

7.170 Main Rotor Gearbox Chip Light Indicator

If MR CHIP light illuminates:

1. Drain and flush gearbox per Section 1.120 except strain oil (a paint filter works well) while draining and examine any particles found in oil or on chip detector.
2. Particles larger than 0.12 inch long or 0.02 inch wide are cause for concern and should be identified as ferrous or non-ferrous with a magnet. If particles are ferrous return main rotor gearbox to RHC for repair along with particles. If particles are non-ferrous, drain and flush gearbox per Section 1.120.
3. If MR CHIP illuminates again within next 100 hours time-in-service a gearbox failure may be imminent. Return gearbox to RHC for repair.

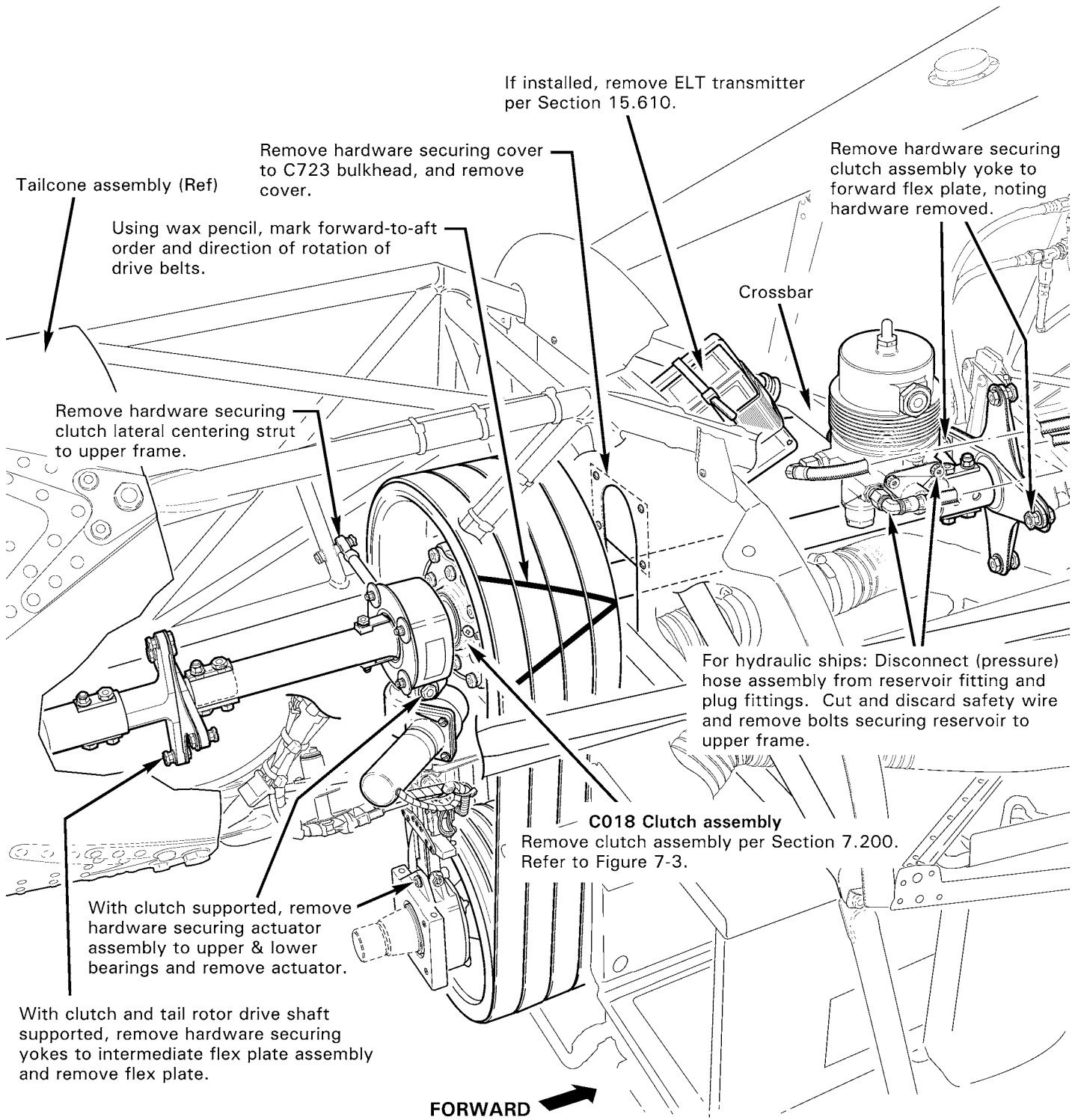

FIGURE 7-2C CLUTCH ASSEMBLY REMOVAL
 (Shown with fanwheel and scroll removed)

7.200 Clutch Assembly

A. Removal

1. Turn BATTERY switch ON and verify actuator is fully disengaged. Turn BATTERY switch OFF.
2. Remove C706-1 tailcone fairing assembly.
3. Remove fanwheel and scroll per Section 6.210.
4. Refer to Figure 7-2C. Remove hardware securing C018 clutch assembly and D224 tail rotor drive shaft assembly yokes to A947-2 (intermediate) flex plate assembly, noting locations of hardware removed. Remove plate assembly. Support drive shaft using a foam block, or equivalent, while drive shaft is disconnected from drive train.
5. Remove hardware securing clutch assembly yoke to C947-1 (forward) flex plate assembly, noting locations of hardware removed. Protect forward flex plate from damage. Support clutch assembly by installing ty-raps around forward and aft yokes, and securing ty-raps to upper frame.
6. For hydraulic ships: Disconnect D205-1 or -11 (pressure) hose assembly from hydraulic reservoir elbow or union, and plug fittings. Cut and discard safety wire, and remove bolts securing reservoir to upper frame. Support reservoir.
7. If installed, remove ELT transmitter per Section 15.610.
8. Remove hardware securing C723-6 cover to C723 bulkhead, and remove cover.
9. Remove hardware securing clutch lateral centering strut to upper frame.
10. Cut and discard ty-raps as required and disconnect actuator wiring from airframe harness at connectors. Remove hardware securing actuator to upper & lower bearings and remove actuator.
11. Remove and discard palnuts securing C907 (forward) yoke and C195 (aft) yoke to clutch shaft. (Palmuts in these locations are no longer required.) Tape clutch shaft, yokes, and yoke hardware as required to protect component from damage during removal.
12. Using wax pencil, mark forward-to-aft order and direction of rotation of drive belts. Support clutch assembly, cut and discard ty-raps securing clutch to upper frame, and remove drive belts.
13. Refer to Figure 7-3. Have a second person support the forward end of the clutch shaft, and the hydraulic reservoir, if installed. Move clutch aft, until forward yoke is aft of upper frame crossbar, then move clutch forward (at an angle) over top of crossbar. Move clutch aft (at an angle), until sheave is clear of the tailcone. Carefully maneuver forward yoke aft through C723 bulkhead.
14. If sending clutch assembly to RHC for repair, remove clutch lateral centering strut, and clutch forward and aft yokes per Sections 7.260 and 7.270.

B. Installation

1. On C018 clutch assembly, install clutch lateral centering strut, and C907 (forward) yoke and C195 (aft) yoke per Sections 7.260 and 7.270, if removed. (Palmuts securing yokes to clutch shaft are no longer required.)

7.200 Clutch Assembly (continued)**B. Installation (continued)**

2. Tape clutch shaft, yokes, and yoke hardware as required to protect component from damage during installation. If not previously accomplished, protect forward flex plate from damage.
3. Refer to Figures 7-2C and 7-3. Have a second person support the hydraulic reservoir, if installed, and prepared to support the forward end of the clutch shaft. Carefully maneuver clutch forward yoke forward through C723 bulkhead. Move clutch forward (at an angle), over top of upper frame crossbar, until sheave and aft yoke are clear of the tailcone. Move sheave and aft yoke up then aft, until forward yoke is aft of crossbar. Move clutch forward into mounting position.
4. Refer to Figure 7-2C. Observe markings and install drive belts in proper forward-to-aft order and direction of rotation (as removed). Support clutch assembly by installing ty-raps around forward and aft yokes, and securing ty-raps to upper frame.
5. Install actuator per Section 7.520, steps a thru d.
6. Install hardware securing clutch assembly yoke to C947-1 (forward) flex plate assembly, using hardware removed. Standard torque nuts and palnuts per Section 1.320, and torque stripe per Figure 2-1.
7. Install hardware securing clutch lateral centering strut to upper frame. Standard torque nut and palnut per Section 1.320, and torque stripe per Figure 2-1. Cut and discard ty-raps securing clutch to upper frame.
8. Install C723-6 cover on C723 bulkhead. Verify security.
9. If removed, install ELT transmitter per Section 15.610.
10. For hydraulic ships: Install bolts securing hydraulic reservoir to upper frame and special torque bolts per Section 1.330. Install 0.032-inch diameter lockwire and safety bolts together in pairs.
11. For hydraulic ships: Torque check hydraulic reservoir union, or elbow jam nut and palnut, per Section 1.330. Remove plugs and connect D205-1 or -11 (pressure) hose assembly to reservoir elbow or union. Special torque hose B-nut per Section 1.330 and torque stripe per Figure 2-1.
12. Perform fanwheel and scroll installation per Section 6.220, steps 1 thru 11.
13. Connect actuator wiring to airframe harness at connectors. Install ty-raps as required to secure wire harness to frame. Cinch ty-raps until snug without over-tightening, and trim tips flush with heads.
14. Perform clutch sheave alignment per Section 7.230.
15. Inspect A947-2 (intermediate) flex plate assembly per Section 2.410. Perform intermediate flex plate installation and shimming per Section 7.330.
16. Install C706-1 tailcone fairing assembly.

NOTE

During initial fanwheel balance, perform "Starting Engine and Run-up" per Pilot's Operating Handbook Section 4, with hydraulics off and cyclic neutralized, to purge air from system.

17. Balance fanwheel per Section 6.240.

7.210 Clutch Assembly Lubricant Inspection and Servicing

NOTE

To retrofit older clutch assemblies with C168-5 retainers, order KI-202 kit. Each C168-5 retainer has a B289-3 screw; screws must be installed on opposite sides of the clutch shaft (when one screw is on top, opposite screw must be on bottom). With C168-5 retainers installed, clutch lubricant inspection and servicing may be performed without clutch removal.

NOTE

Sprag clutch housing capacity is approximately 4 fl oz (118 ml).

A. Clutch Assemblies with C168-5 Retainers

WARNING

Avoid contaminating drive belts and sheaves with lubricant. Clean contaminated surfaces with mild soap and water solution, followed by a warm water rinse. Place a clean, absorbent rag beneath MT147-2 fittings, when installed, to catch any drips.

1. Remove C706-1 tailcone fairing assembly. Remove hardware securing C723-6 cover to C723 bulkhead and remove cover.
2. Rotate clutch shaft until bolts securing yokes to shaft are vertical. Engage rotor brake.
3. Rotate sheave until forward retainer B289-3 screw is on top. Remove screw and install clean MT147-2 fitting. Attach drain hose.
4. Rotate sheave until fitting and attached drain hose are on bottom. Route drain hose into a suitable, clean container. Remove aft retainer B289-3 screw and allow lubricant to drain into container.
5. Install second clean MT147-2 fitting in aft retainer and connect a clean supply of A257-4 lubricant to fitting. Flush sprag clutch housing until exiting lubricant is obviously red. Disconnect lubricant supply and allow lubricant to drain completely into container.
6. Strain all lubricant from container through a 180-200 micron paint filter/strainer. Fluid may be dark, and may sparkle with very fine metallic debris; this is normal. If metallic debris is trapped in the filter/strainer, remove clutch assembly and return it to RHC, or an R44 Service Center authorized to overhaul clutch assemblies, for disassembly and inspection.
7. If metallic debris is not found in the filter, attach drain hose to (top) aft retainer fitting. Route drain hose into a suitable container. Connect a clean supply of A257-4 lubricant to (bottom) forward retainer fitting. Fill sprag clutch housing thru bottom fitting until no air bubbles are visible in drain hose. Shut-off fluid flow.

7.210 Clutch Assembly Lubricant Inspection and Servicing (continued)**A. Clutch Assemblies with C168-5 Retainers (continued)**

8. Remove (top) aft retainer fitting and install screw. Rotate sheave until forward retainer fitting is on top. Remove fitting and verify lubricant level contacts threads; add lubricant as required. Install forward screw.
9. Install C723-6 cover on C723 bulkhead. Install C706-1 tailcone fairing assembly.

B. Clutch Assemblies with Retainers without B289-3 Screws

1. Perform clutch assembly (aft) seal replacement per Section 7.213.

Intentionally Blank

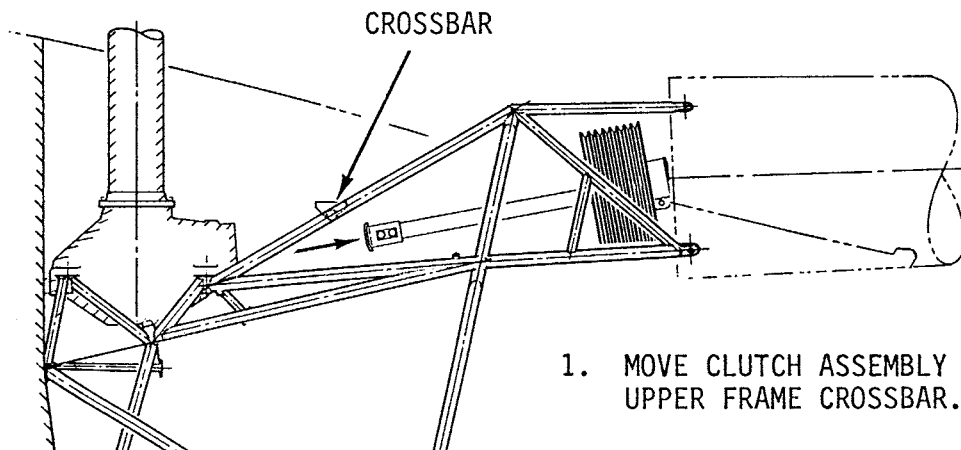

1. MOVE CLUTCH ASSEMBLY AFT AND UNDER UPPER FRAME CROSSBAR.

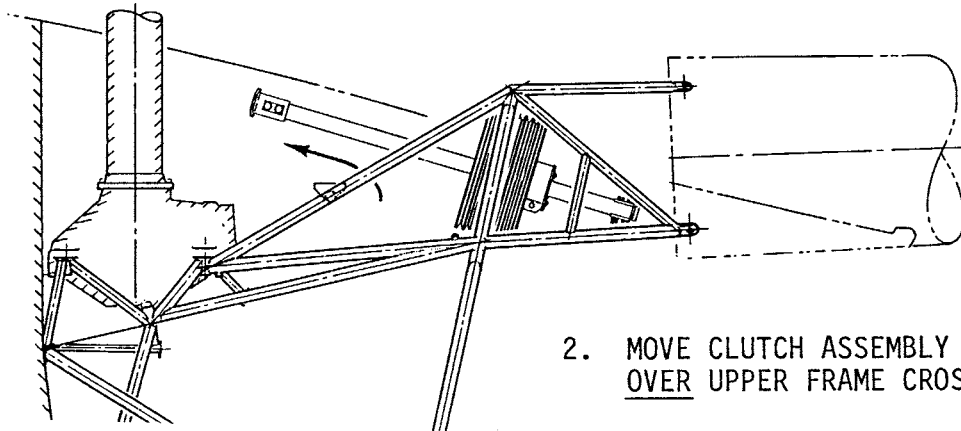

2. MOVE CLUTCH ASSEMBLY FORWARD UP AND OVER UPPER FRAME CROSSBAR.

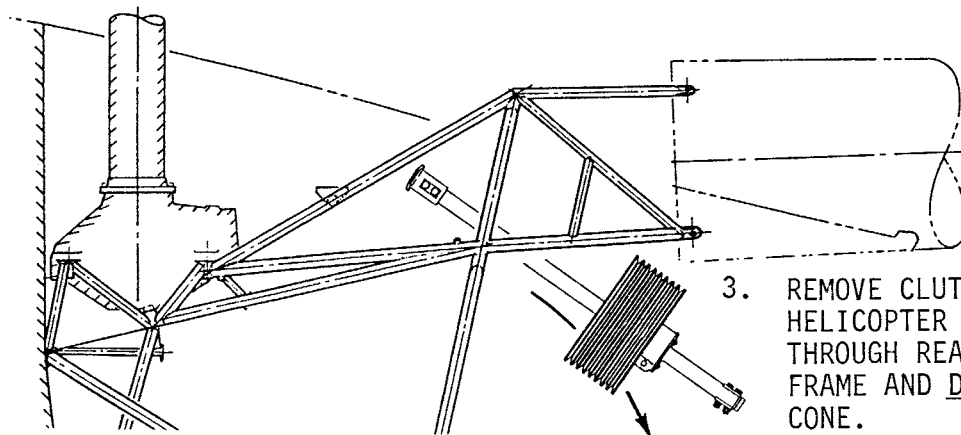

3. REMOVE CLUTCH ASSEMBLY FROM HELICOPTER BY LOWERING AFT THROUGH REAR SECTION OF UPPER FRAME AND DOWN BELOW TAIL CONE.

FIGURE 7-3 CLUTCH REMOVAL

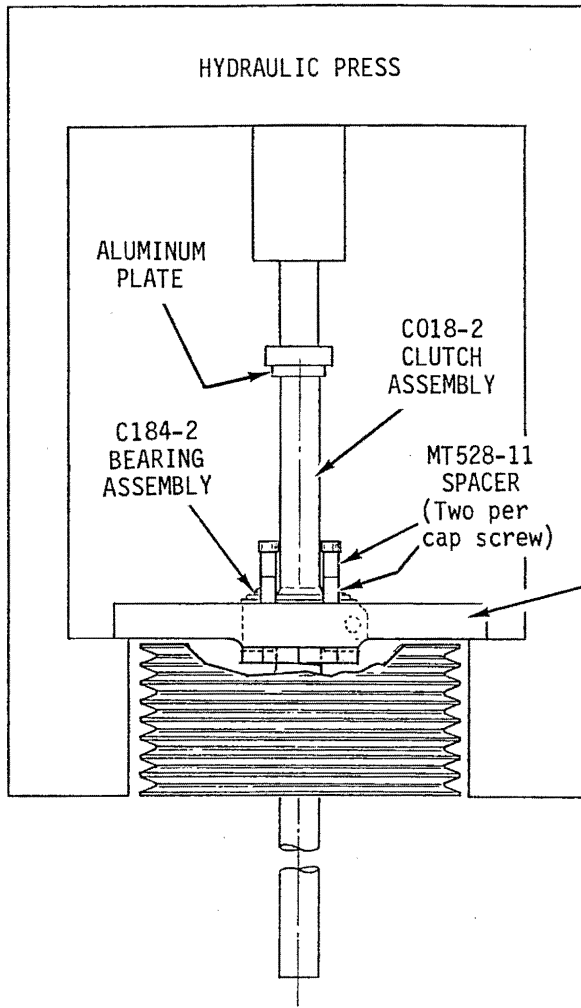

FIGURE 7-3A

REMOVAL OF C184-2 BEARING ASSEMBLY USING HYDRAULIC PRESS AND MT528-1 REMOVAL TOOLS.

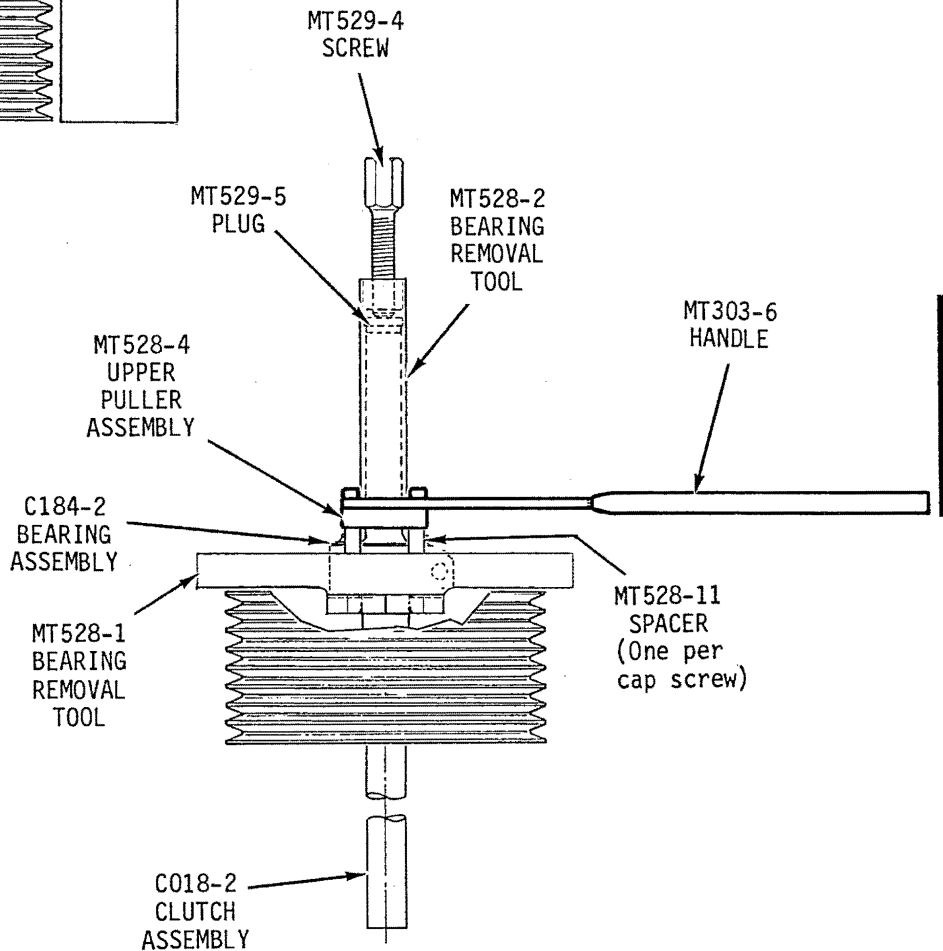

FIGURE 7-3B

REMOVAL OF C184-2 BEARING ASSEMBLY WHEN HYDRAULIC PRESS IS NOT AVAILABLE; USE MT528-1 AND MT528-2 REMOVAL TOOLS.

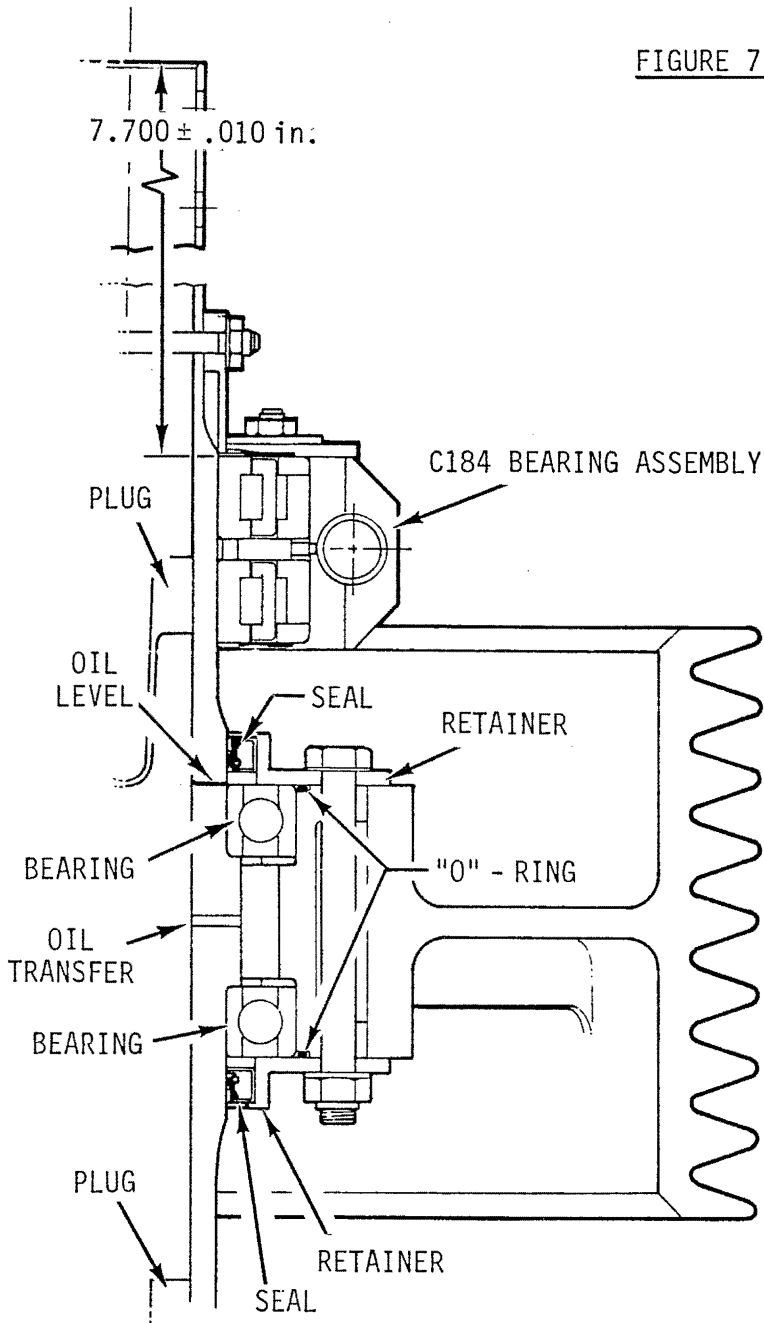

FIGURE 7-3C

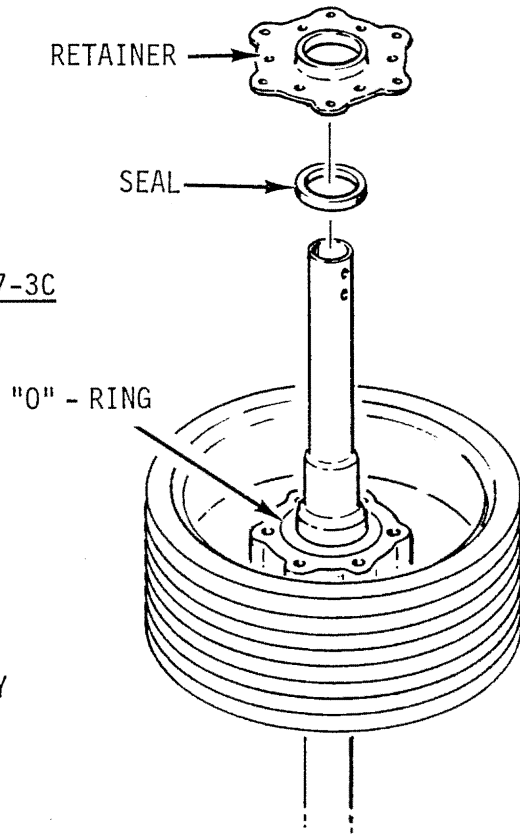

FIGURE 7-3D

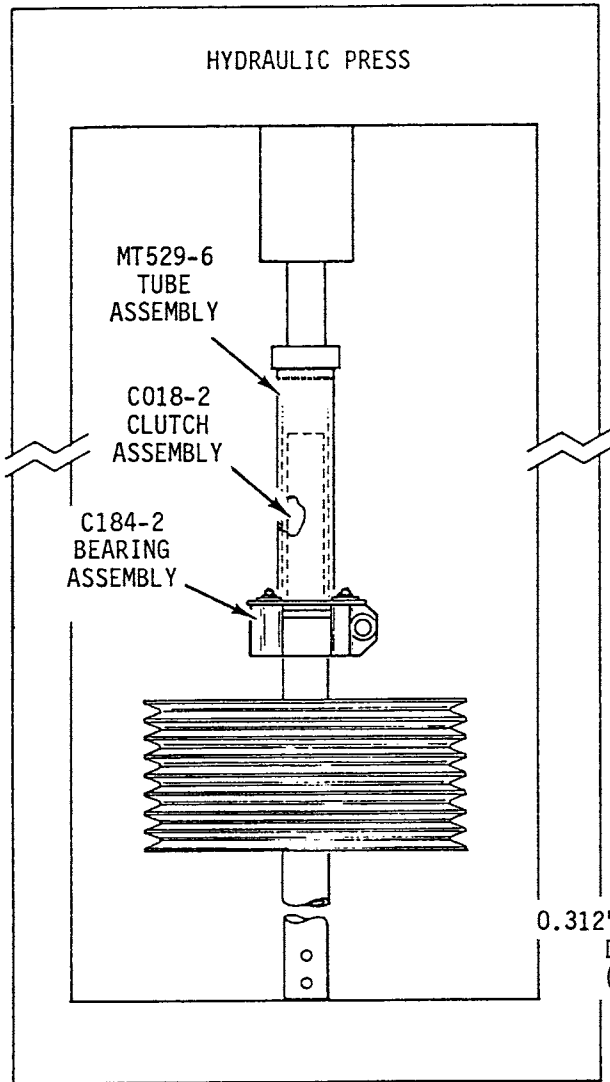

FIGURE 7-3E

INSTALLATION OF C184-2 BEARING USING HYDRAULIC PRESS AND MT528-1 INSTALLATION TOOLS.

WARNING
DO NOT PRESS ACROSS SHEAVE OR BEARINGS WILL BE DAMAGED.

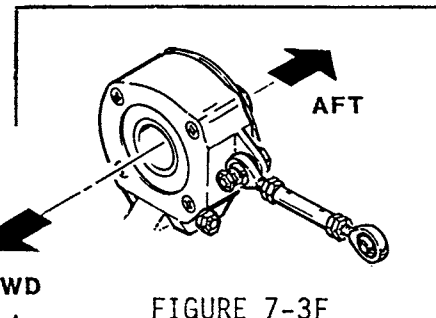

FIGURE 7-3F

INSTALL C184-2 BEARING ASSEMBLY ONTO SHAFT WITH NUTS FACING AWAY FROM CLUTCH.

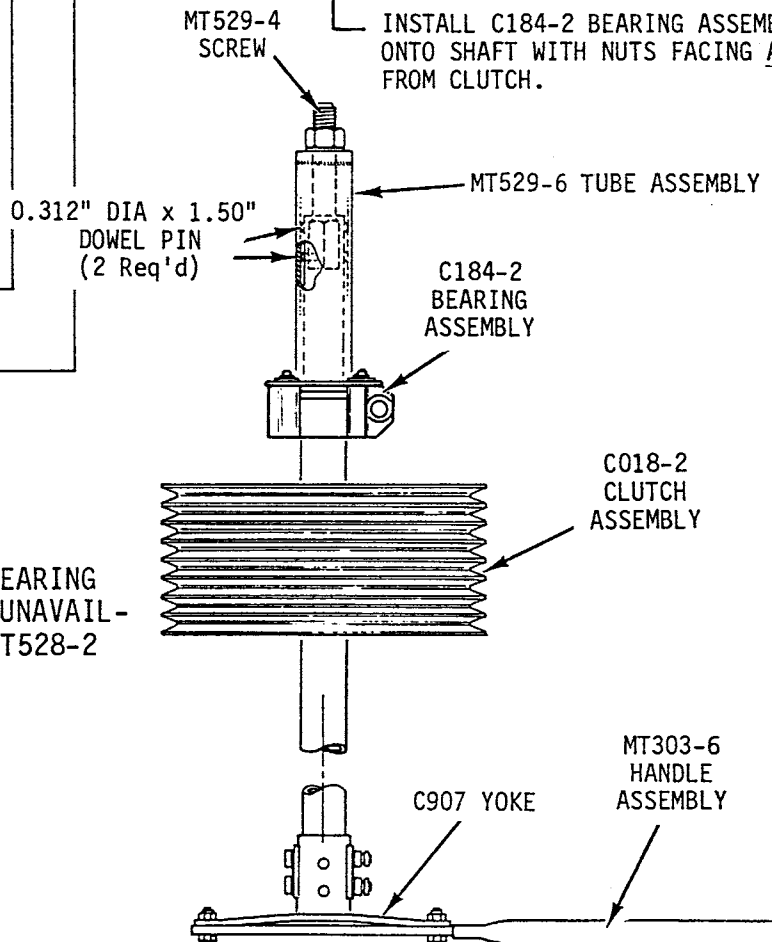

FIGURE 7-3G

INSTALLATION OF C184-2 BEARING WHEN HYDRAULIC PRESS IS UNAVAILABLE; USE MT528-1 AND MT528-2 INSTALLATION TOOLS.

Intentionally Blank

7.211 C184 Bearing Assembly Removal

- a. Remove clutch assembly per Section 7.210.
- b. Remove C195 yoke per Section 7.270.
- c. Remove C191-5 stops.
- d. Remove bearing assembly as follows:

Using a hydraulic press:

1. Install MT528-1 bearing removal tool per Figure 7-3A.
2. Support MT528-1 bearing removal tool on hydraulic press per Figure 7-3A.
3. Install aluminum plate between clutch shaft and press ram per Figure 7-3A to protect end of shaft.
4. Press until C184-2 bearing is removed from the shaft.

CAUTION

Hold clutch assembly to prevent clutch from falling to the floor.

Without a hydraulic press:

1. Install MT528-1 and MT528-2 bearing removal tools per Figure 7-3B. Use only one MT528-11 spacer at each cap screw. Ensure MT529-4 screw threads are coated with anti-seize.
2. Remove bearing assembly by holding handle and tightening screw.

This page intentionally left blank.

7.212 C184 Bearing Assembly Installation

1. Remove loose paint and clean mating area on clutch shaft. If reusing a bearing assembly, inspect condition of seals and inner races.
2. Heat C184 bearing assembly to 200° F maximum (approximately 5 minutes in 200°F oven). Monitor bearing temperature with a pyrometer or a telatemp.
3. Coat bearing shoulder on clutch shaft with zinc-chromate or epoxy primer. While primer is still wet, install bearing assembly on clutch shaft:

NOTE

Do NOT install bearing with B270-10 adhesive.

NOTE

Be sure to put side of C184 bearing assembly with nuts facing away from clutch (see Figure 7-3F).

- a. Using a hydraulic press: Support clutch assembly at forward end of clutch shaft. Place MT529-6 tube assembly on clutch shaft per Figure 7-3E. Center tube assembly over inner race of bearing assembly. Press bearing assembly until MT529-6 tube assembly bottoms on end of clutch shaft (bearing assembly should be at dimension shown in Figure 7-3D).

CAUTION

Do NOT support clutch assembly at sheave or internal bearings will be damaged.

- b. Without hydraulic press: Use MT529-6 tube assembly (included in MT528-1 tool set) and MT528-2 tool set as shown in Figure 7-3G. Center tube assembly over inner race of C184 bearing assembly. Tighten nut onto MT529-4 screw (coat nut face and screw with anti-seize) until MT529-6 tube assembly bottoms on end of clutch shaft (bearing assembly should be at dimension shown in Figure 7-3D).
4. Remove bearing press tooling.
 5. Check bearing for smooth rotation.
 6. Seal bearing inner race-to-shaft juncture with primer to minimize corrosion.
 7. Torque stripe inner race of bearing to clutch shaft two places, 180° apart.
 8. Install C191-5 stops. Torque bolts per Section 1.130 and torque stripe.
 9. Install new telatemp on C184 bearing housing if original was altered by heating.
 10. Install clutch assembly C195 aft yoke per Section 7.270.

7.213 Clutch Assembly Seals Replacement

NOTE

To retrofit older clutch assemblies with C168-5 retainers, order KI-202 kit.

1. Remove clutch assembly per Section 7.200.
2. a. If replacing aft seal, remove C184 bearing per Section 7.211.
b. If replacing forward seal, remove C907 yoke per Section 7.260. If C168 retainers lack B289-3 screws, also remove C184 bearing per Section 7.211 due to lubricant filling requirements.
3. Remove loose paint from clutch shaft, then thoroughly clean entire clutch assembly.

NOTE

Sprag clutch housing capacity is approximately 4 fl oz (118 ml). Retain drained lubricant in a suitable, clean container.

CAUTION

Some clutch assemblies have roller bearings and require two bearing-preload shims under each retainer; do NOT lose shims when removing retainer(s).

4. Position clutch assembly horizontally with upper sheave resting in a clean, non-marking container. Remove bolts and associated hardware and both NAS1352 screws securing affected seal retainer. Remove retainer and keep both shims (used with roller bearings only) in place. Discard o-ring. Rotate clutch shaft until yoke attachment holes are vertical and allow lubricant to drain into container (shaft oil transfer holes are parallel with yoke attachment holes).
5. Flush cavity containing bearings and sprag clutch with clean A257-4 lubricant until lubricant draining into container is obviously red.
6. Strain all lubricant from container through a 180-200 micron paint filter/strainer. Lubricant may be dark, and may sparkle with very fine metallic debris; this is normal. However, if metallic debris is trapped in the filter, submit clutch assembly to RHC, or an R44 Service Center authorized to overhaul clutch assemblies, for repair.
7. Press old seal out of retainer and discard seal. Clean and dry retainer bore.
8. Press new seal, with flat face outboard, into retainer until it seats against retainer lip.

NOTE

If C168-5 retainers are installed, B289-3 screws must be on opposite sides of the clutch shaft (when one screw is on top, opposite screw must be on bottom).

7.213 Clutch Assembly Seals Replacement (cont'd)

9. If replacing forward seal, position clutch assembly vertically with long end of shaft pointing up. Lightly lubricate new o-ring and seal inner lip with A257-4 lubricant, install o-ring in clutch housing forward groove, and slide retainer over clutch shaft forward end. If installed, ensure both shims are properly positioned against roller bearing outer race. Align retainer and housing screw holes and install NAS1352 screws.
10. Position clutch assembly vertically with short end of shaft pointing up.
11. a. If retainers lack B289-3 screws, remove aft retainer and keep both shims (used with roller bearings only) in place. Discard o-ring. Lightly lubricate new o-ring with A257-4 lubricant and install in clutch housing aft groove.
b. If retainers have B289-3 screws and aft retainer has not been removed, remove B289-3 screw from aft retainer.
12. With clutch assembly remaining vertical, fill housing with A257-4 lubricant until lubricant level is flush with top of bearing races per Figure 7-3D.
13. a. If retainers lack B289-3 screws, lightly lubricate aft retainer seal inner lip with A257-4 lubricant and slide retainer over clutch shaft aft end. If installed, ensure both shims are properly positioned against roller bearing outer race. Align retainer and housing screw holes and install NAS1352 screws.
b. If retainers have B289-3 screws, install B289-3 screw in aft retainer.
14. Position clutch assembly horizontally and rotate clutch shaft until yoke attachment holes are vertical. Allow lubricant to transfer internally for two minutes.
15. Repeat steps 10 thru 14 until no more lubricant can be added.
16. Install bolts and associated hardware securing C168 retainers to sheave. Using a criss-cross pattern, standard torque bolts per Section 1.320 and torque stripe per Figure 2-1.
17. Tighten four cap screws securing retainers to sheave and torque stripe per Figure 2-1.
18. Install C184 bearing assembly per Section 7.212, as required. Install C907 yoke per Section 7.260, as required.
19. Install clutch assembly per Section 7.200, as required.

7.220 (Reserved)

Intentionally Blank

Intentionally Blank

Intentionally Blank

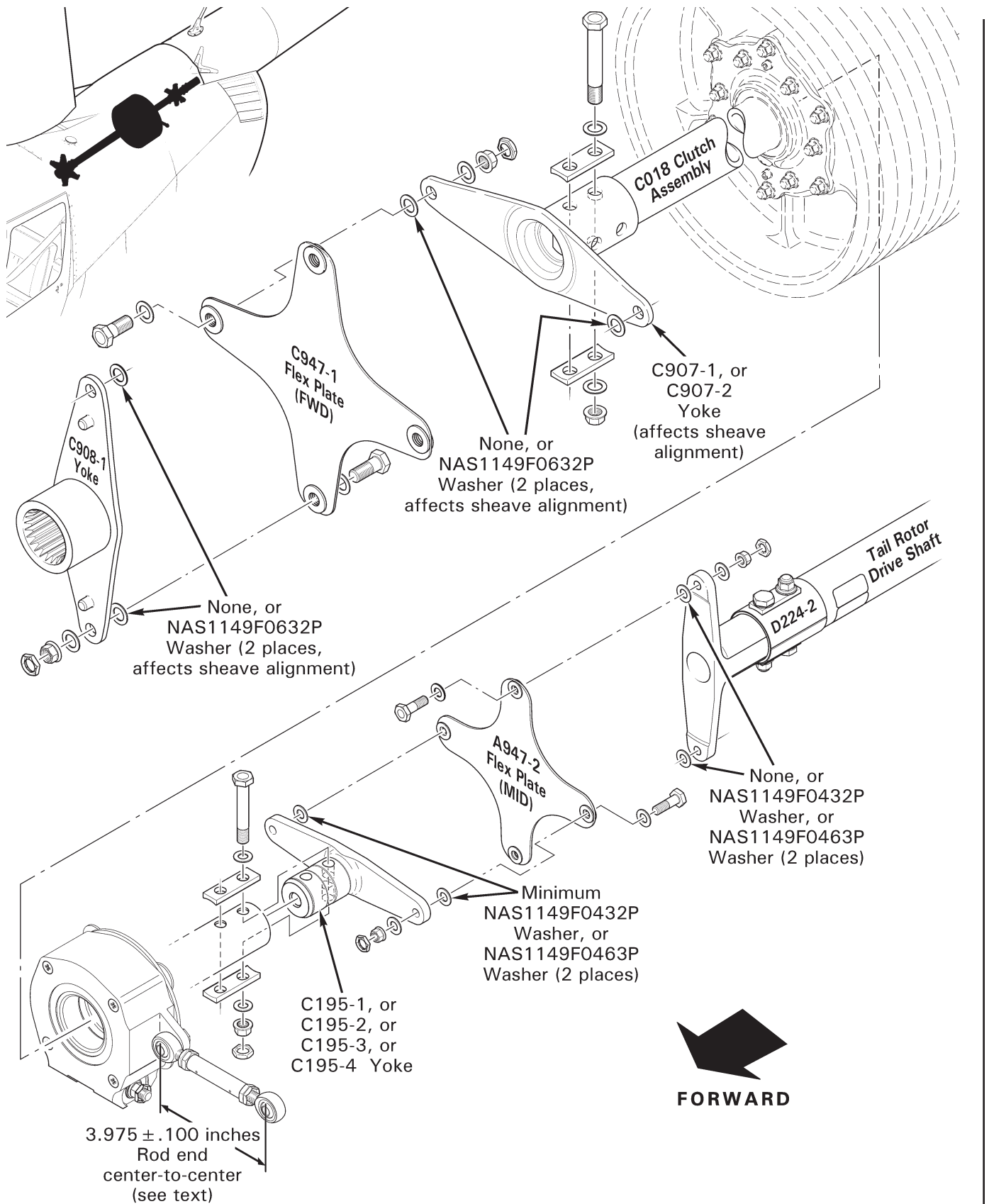

FIGURE 7-4 FORWARD AND INTERMEDIATE FLEX PLATE INSTALLATION

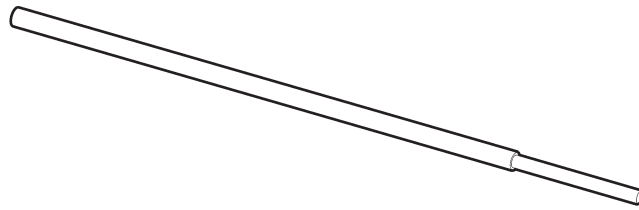

FIGURE 7-5 MT331-4 SHEAVE ALIGNMENT BAR

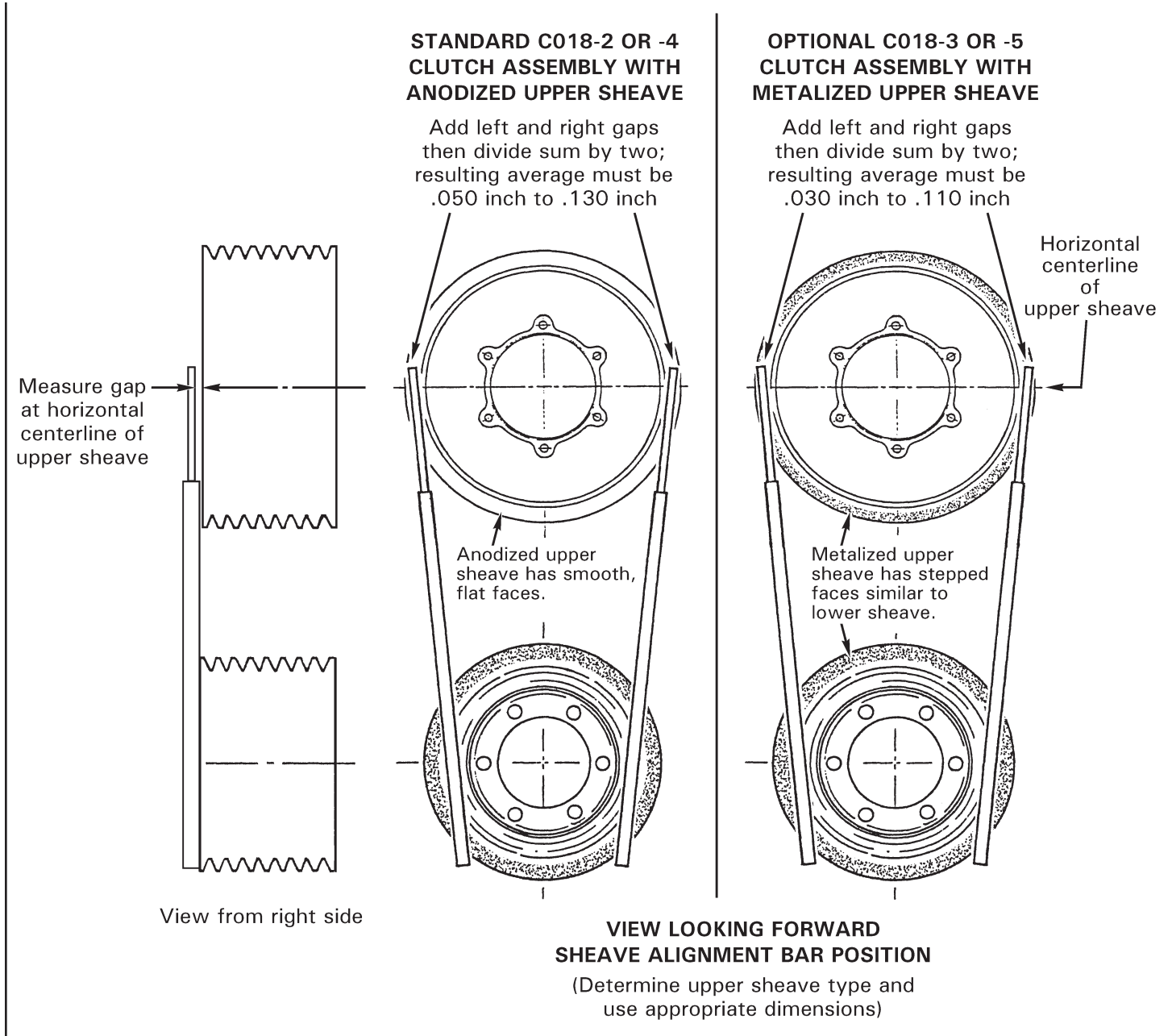

FIGURE 7-6 SHEAVE ALIGNMENT DIMENSIONS

7.230 Clutch Sheave Alignment

Checking sheave alignment:

1. Engage clutch.
2. Adjust length of lateral centering strut, if required, to center upper sheave in steel tube frame. If length was adjusted, standard torque attach bolts, jam nuts, and palnuts per § 23-32 and torque stripe per Figure 2-1.
3. Hold MT331-4 Sheave Alignment Bar against aft face of lower sheave extending bar upward to horizontal center line of upper sheave.
4. Measure left and right gaps per Figure 7-6. Average of both gaps must be within noted limits.

If average gap exceeds maximum limit then upper sheave is too far forward and must be moved aft by:

- Shimming forward flex plate, and/or
- Adjusting C907 yoke length.

Shimming is accomplished by installing a maximum of one NAS1149F0632P washer between C947-1 flex plate and both arms of C907 and/or C908 yoke; NAS1149F0632P washers installed on either yoke will decrease gap an amount equal to washer thickness. Each C907 yoke has two sets of mounting holes which change the effective yoke length by 0.120 inch. The C907-2 yoke is either 0.120 inch or 0.240 inch longer than the long position of the C907-1 yoke. Gap will decrease by 0.120 inch with each 0.120 inch increase in C907 yoke length.

If average gap is smaller than minimum limit then upper sheave is too far aft and must be moved forward by:

- Removing shims (if installed) at forward flex plate, and/or
- Adjusting C907 yoke length.

Removing NAS1149F0632P washers from between C947-1 flex plate and both arms of C907 and/or C908 yoke will increase gap an amount equal to washer thickness. Each C907 yoke has two sets of mounting holes which change the effective yoke length by 0.120 inch. The C907-1 yoke is either 0.120 inch or 0.240 inch shorter than the short position of the C907-2 yoke. Gap will increase by 0.120 inch with each 0.120 inch decrease in C907 yoke length.

5. Check intermediate flex plate shimming per § 7.330 if shim washers were added or removed at C947-1 flex plate or if C907 yoke length was altered.
6. Rotate drive train by hand. Verify operating clearance with belt tension actuator disengaged, and with belt tension actuator engaged.

7.240 Clutch Shaft Angle

No check of the clutch shaft angle is required.

7.250 [Reserved.]

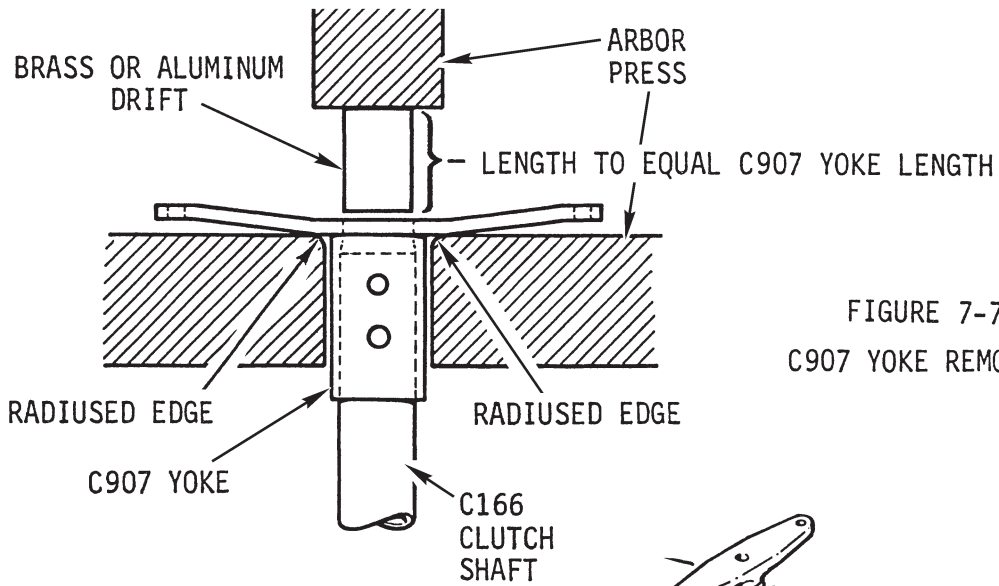

FIGURE 7-7
C907 YOKE REMOVAL

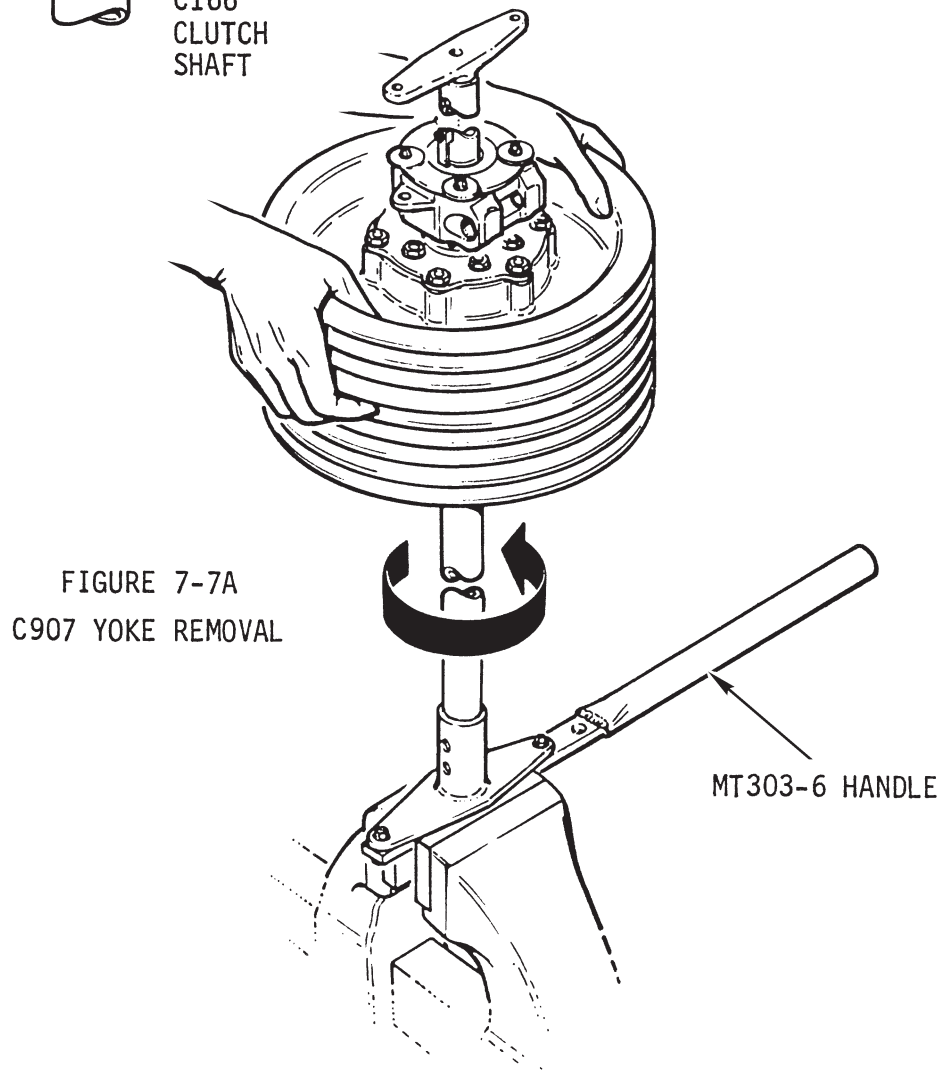

FIGURE 7-7A
C907 YOKE REMOVAL

7.260 C907 Yoke Removal and Installation

A. Removal

1. Remove the clutch assembly per § 7.210.
2. Remove bolts and clamping blocks securing C907 yoke to clutch shaft. Mark which set of yoke attachment holes are used.
3. Remove C907 yoke:
 - a. (Preferred method). If press is available, position clutch assembly in press per Figure 7-7. Ensure brass or aluminum drift fits against outer rim of clutch shaft and not against inner spacer. Press clutch shaft out of yoke.

CAUTION

Ensure clutch assembly does not fall when yoke is removed.

- b. If a press is not available, tightly secure C907 yoke arms to MT303-6 handle using NAS6606 bolts. Refer to Figure 7-7A. Clamp handle in a vise and twist clutch shaft out of yoke by turning upper sheave. Apply penetrating oil to yoke-shaft juncture as required. If difficulty is encountered, remove handle and arrange to use a press as described in preceding step.

CAUTION

Avoid bending loads on clutch shaft when handle is clamped in vise as C907 yoke can be damaged.

B. Installation

1. Remove loose paint and clean mating area on shaft with non-residue solvent. |
2. Coat inside of C907 yoke and mating portion of clutch shaft with zinc-chromate or epoxy primer. While primer is still wet, install yoke on clutch shaft and align marked holes on yoke (if applicable) with clutch shaft holes.
3. Secure yoke to shaft with clamping blocks and bolts. Standard torque bolts per § 23-32 and torque stripe per Figure 2-1. |

7.270 C195 Yoke Removal and Installation**A. Removal****NOTE**

Yoke may be removed without clutch removal.

1. Remove intermediate flex plate.
2. Remove bolts and clamping blocks securing C195 yoke to clutch shaft.
3. Twist yoke out of clutch shaft.

B. Installation

1. Remove loose paint and clean mating area inside shaft with non-residue solvent.
2. Coat inside of clutch shaft and shank of C195 yoke with zinc-chromate or epoxy primer. While primer is still wet, slide yoke into clutch shaft and align holes.
3. Install clamping blocks and bolts. Standard torque bolts per § 23-32 and torque stripe per Figure 2-1.
4. Install intermediate flex plate per § 7.330.

CAUTION

There must be (1) NAS1149F0432P or (1) NAS1149F0463P washer between each arm of C195 yoke and A947-2 flex plate. Refer to § 7.330.

7.280 V-Belts**7.281 V-Belt Removal**

- a) Remove tailcone cowling.
- b) Lower clutch actuator to its fully disengaged position.
- c) Mark the back of each belt with a felt pen. Use numbers or a v-mark to indicate direction and order so they will be in the same positions if they are to be reinstalled. Mark the direction of rotation on each belt so that they cannot be reversed.
- d) Mark and disconnect the intermediate flex plate from clutch. Disconnect the centering strut from clutch to upper frame at frame end.
- e) Remove fan and scroll per Section 6.200.
- f) Remove actuator assembly per Section 7.510.
- g) Remove belts from sheave.

CAUTION

Used belts must be reinstalled in proper order due to individual differences in belt stretch.

7.282 V-Belt Installation**WARNING**

Install V-belts only in matched sets. Do Not install used V-belts from another helicopter.

- a) Before installation of new belts, inspect the sheave grooves. Replace any sheave showing corrosion, pitting or flaking of the metalized or anodized coatings, wear through the anodized coating, roughness, or sharp ridges.

CAUTION

Rough or corroded grooves in the upper or lower sheave can cause V-belts to roll, break, or come off. Refer also to Section 2.160.

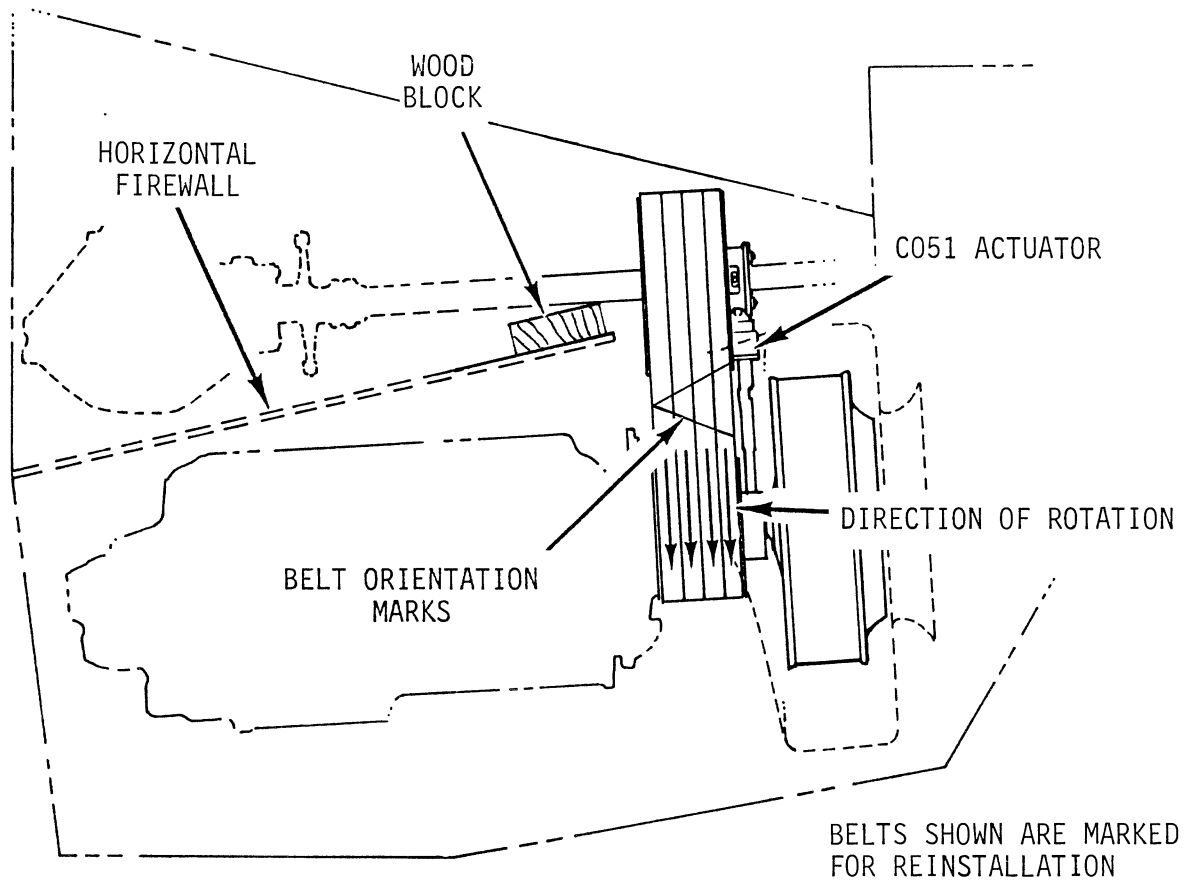

FIGURE 7-8 V-BELT AND ACTUATOR REMOVAL

7.282 V-Belt Installation (cont'd)

- b) Paint the grooves in the lower sheave with a thin coating of zinc chromate or epoxy primer per Section 1.400.
- c) Install belts on sheaves. If used belts are reinstalled, inspect them for damage per Section 2.150. Make sure they are in their proper order with respect to fore/aft position and proper direction of rotation.
- d) Install the actuator assembly per Section 7.520.
- e) Connect the intermediate flex plate to the clutch.
- f) Install fan and scroll per Section 6.200.
- g) Check clutch sheave alignment per Section 7.230.
- h) Shim and connect intermediate flex plate per Section 7.330.
- i) Adjust the actuator's down-limit stop screw so when the actuator is engaged at start up there is a delay of less than 5 seconds before rotor starts turning.

NOTE

First adjustments of the actuator down limit screw, to regulate new belt disengage slack, occur relatively soon with longer periods between later adjustments. Recheck.

A delay between clutch switch engagement and the rotor starting to turn of more than 5 seconds indicates excessive slack. If rotor rotates when cranking engine with starter motor, belts may not have enough slack.

CAUTION

During start up and engagement, belts too tight can damage flex plates and belts too loose can jump out of grooves.

- j) Ground run or hover the helicopter for at least 20 minutes.
- k) At the end of the ground run, inspect the sheave grooves for the contact pattern in the primer. A similar contact pattern in all eight grooves indicates the belt/sheave combination is compatible. A noticeably different contact pattern from groove to groove indicates the combination is not compatible.
- l) If the belt/sheave combination is not compatible, re-check sheave alignment, replace belts, and repeat installation procedure. If belt/sheave combination is still not compatible, it may be necessary to replace the lower sheave. The wear pattern in all eight grooves must be similar before the aircraft is released for flight.

7.283 Belt Tension

No procedure for checking belt tension on the helicopter is required.

7.290 C007 Fanshaft and Bearing Assembly, Starter Ring Gear Support, Lower Sheave and Alternator Belt Replacement.

7.291 Removal

- a) Remove V-belts per Section 7.281.
- b) Cut the safety wire and remove the six NAS6608 bolts holding the fanshaft.
- c) Remove the C007 fanshaft and bearing assembly. Temporarily secure the lower sheave with one of the removed bolts if it is not to be removed.
- d) To remove the lower sheave, the use of a soft mallet may be required to tap the sheave while pulling it off.
- e) Removal of the starter ring gear support is required to change alternator belt or gain access to the nose section of the engine.
 - 1) Loosen the alternator belt tension.
 - 2) Note the zero mark on the starter ring gear support at one propeller flange bushing. Mark this bushing to ease reinstallation.
 - 3) Remove the starter ring gear support.

7.292 Installation

- a) Install a new alternator belt at this time if required. Reinstall the starter ring gear support. Align the zero mark on the ring gear support with the marked bushing. The bushing and matching hole are slightly larger than the five other holes. This makes the incorrect installation of the starter ring gear support difficult but not impossible.
- b) Install the lower sheave and fanshaft assembly. Check that two AN960-816 washers are installed under each NAS6608-42H bolt. Lightly snug the bolts. Check for clearance between the lower sheave and starter ring gear support's conical surface. Insert a 0.005 inch feeler gauge at 6 places between the attachment bolts. Lack of clearance indicates the wrong starter ring gear support is installed or that the ring gear support is improperly installed. Torque the bolts per Section 1.330 in a star pattern followed by a circular pattern. Safety wire the bolts in pairs with 0.041 inch diameter stainless steel safety wire.

7.290 C007-4 Fanshaft and Bearing Assembly, Starter Ring Gear Support, Lower Sheave and Alternator Belt Replacement (cont'd)**CAUTION**

Reinstalling the bolts with less than two AN960-816 washers may cause the bolt shank to bottom on the engine propeller flange bushing. This condition would not clamp the lower sheave and fanshaft assembly securely to the engine flange.

- c) Tension the alternator belt at the pulley nut at this time. The slip torque at the pulley nut for a new belt is 11-13 ft-lb; for a used belt, the slip torque is 7-9 ft-lb.
- d) Reinstall V-belts per Section 7.282.

7.300 TAIL ROTOR DRIVE SHAFT**7.310 Tail Rotor Drive Shaft Removal**

- a) Remove the tailcone per Section 4.311.
- b) Use a 3-foot socket extension with a 3/8-inch socket to disconnect the two NAS6603 bolts which hold the drive shaft damper arm to its mounting bracket.
- c) Using the upper aft tailcone inspection hole, disconnect the C947-3 aft flex plate from tail rotor gearbox input shaft flange. Support the aft end of the drive shaft so it cannot fall and damage the drive shaft or tailcone.
- d) The drive shaft can now be pulled out of the forward end of the tailcone

7.320 Tail Rotor Drive Shaft Installation

- a) Insert tail rotor drive shaft into tailcone.

NOTE

If aft flex plate was disconnected from tail rotor gearbox and removed, first connect flex plate to the drive shaft and then insert the drive shaft into tailcone. Torque the NAS6604 bolts per Section 1.320.

- b) Support drive shaft through upper aft tailcone inspection hole to prevent damage and for alignment purposes.
- c) Using the upper aft tailcone inspection hole, connect the C947-3 aft flex plate to gearbox with the bolt heads against the flex plate. Use one AN960-416L washer under the bolt head. Torque to per Section 1.320.

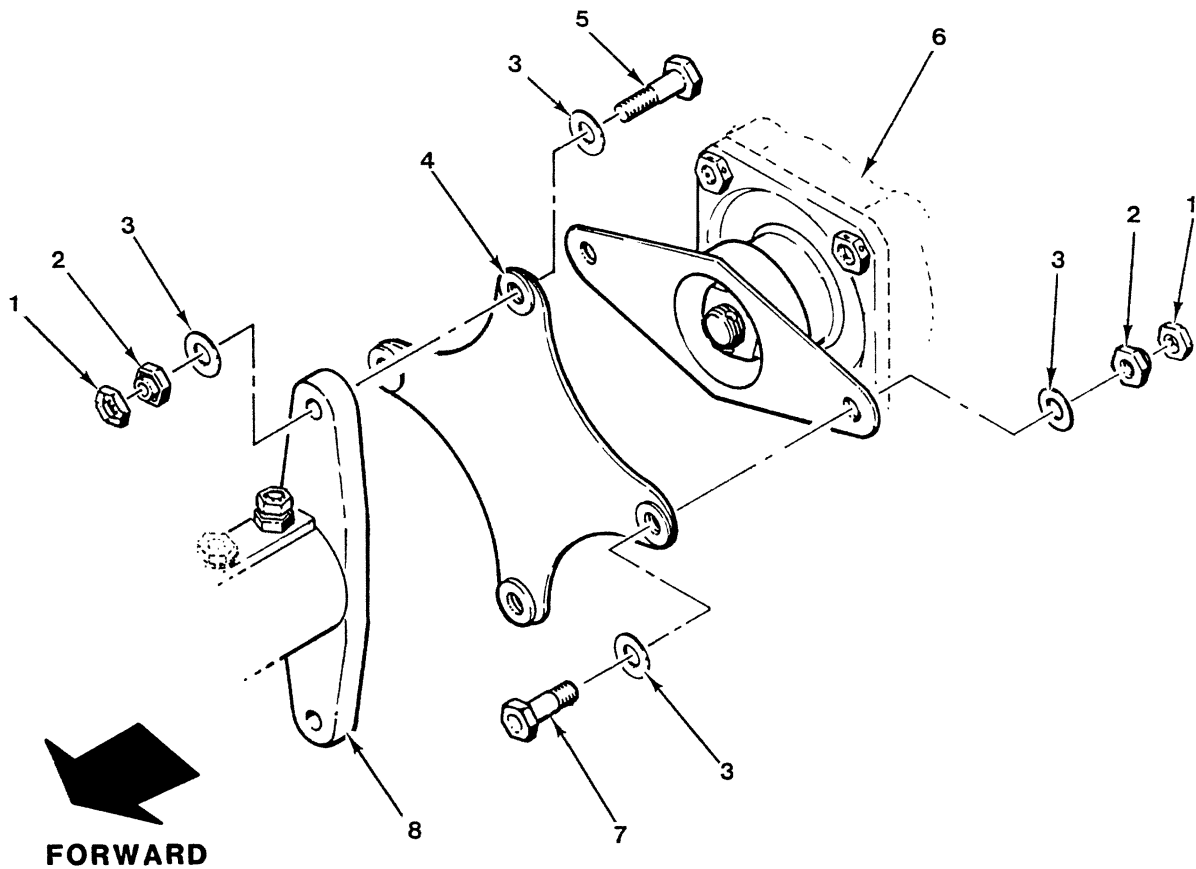

FIGURE 7-9 AFT FLEX PLATE INSTALLATION

<u>NUMBER</u>	<u>PART NO.</u>	<u>DESCRIPTION</u>
1	B330-13	PALNUT
2	NAS679A4	NUT
3	AN960-416L	WASHER
4	C947-3	FLEX PLATE (AFT)
5	NAS6604-7	BOLT
6	C021-1	TAIL ROTOR GEARBOX
7	NAS6604-4	BOLT
8	D224-1	TAIL ROTOR DRIVE SHAFT ASSEMBLY

7.320 Tail Rotor Drive Shaft Installation (cont'd)**CAUTION**

Improper installation of flex plate can damage tail rotor drive shaft and gearbox.

- d) Through inspection holes on side of tailcone, determine longitudinal alignment of damper arm with tailcone attachment bracket. If clearance or interference between arm and bracket is greater than 0.12 inches, contact Robinson Helicopter Technical Support Department. If clearance or interference is less than 0.12 inch, connect damper assembly to tailcone cross member. Torque bolts per Section 1.320.
- e) Install tailcone per Section 4.312.
- f) Install and shim intermediate flex plate per Section 7.330.
- g) Perform tail rotor drive shaft run-out check per Section 7.340.

7.321 Adjustment of Damper Friction

- a) Remove tail rotor drive shaft from tailcone per Section 7.310.
- b) Disassemble damper per Figure 7-10.
- c) Inspect C041-5 DU washers for worn Teflon® coating (dark gray face) and replace as required.
- d) Inspect A141-37 washers and C041-3 arm for indications of wear or grooving. Replace as required.
- e) Reassemble damper per Figure 7-10. Torque pivot bolts per Section 1.320.

CAUTION

Teflon® (dark gray) face of C041-5 DU washer must be placed against A141-36 washer or C041-3 link. Remove plastic or tape coating if installed.

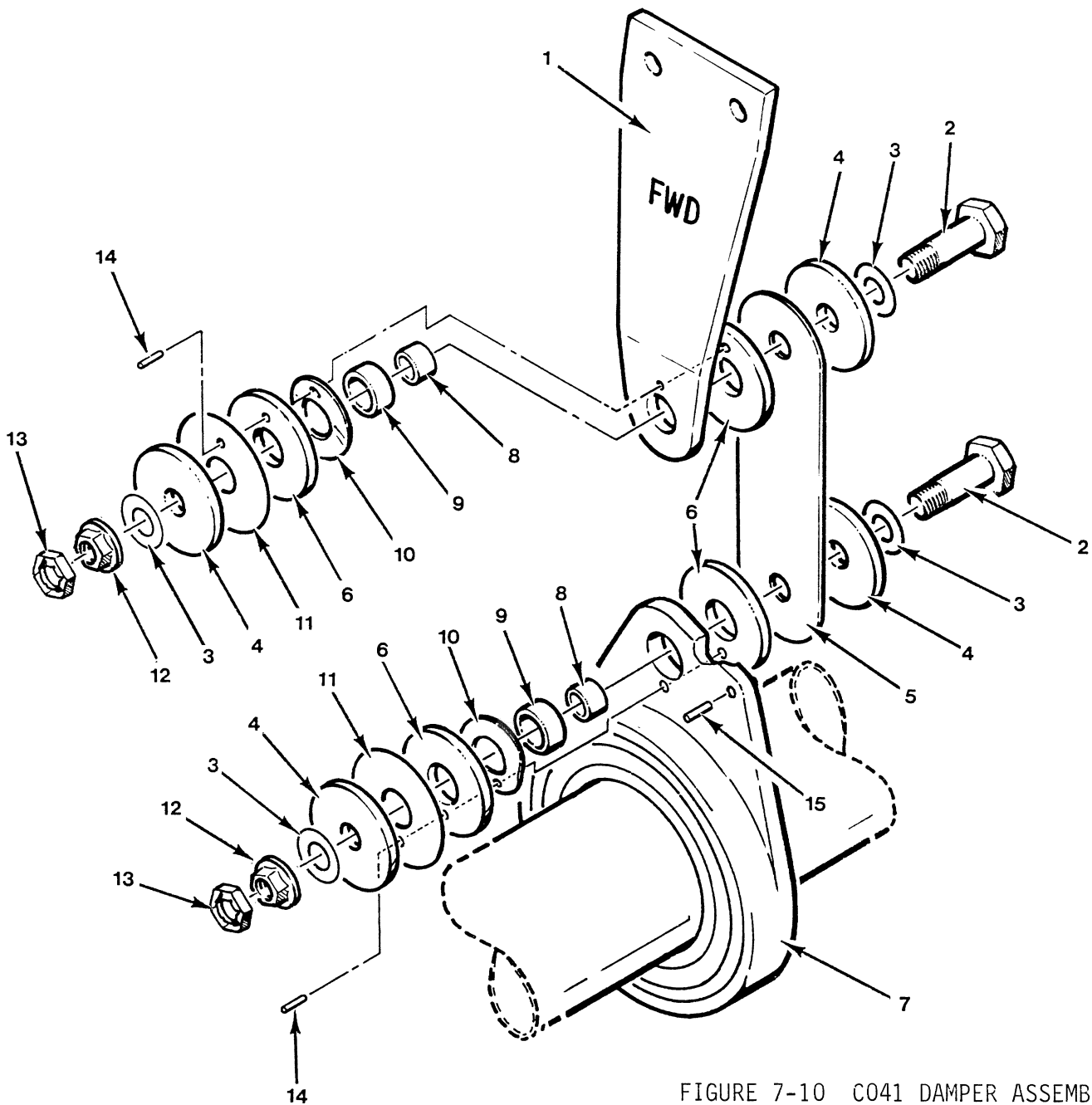

FIGURE 7-10 C041 DAMPER ASSEMBLY

NUMBER	PART NUMBER	DESCRIPTION	NUMBER	PART NUMBER	DESCRIPTION
1	C041-8	Arm	9	05DU04	Bushing
2	NAS6604-6	Bolt	10	C041-6	Spring Washer
3	AN960PD416L	Washer	11	A141-36	Washer
4	A141-37	Washer	12	NAS679A4	Nut
5	C041-3	Link	13	B330-13	Palnut
6	C041-5	Washer	14	A041-10	Dowel Pin
7	C041-11	Bearing Assembly	15	MS16562-11	Roll Pin
8	A105-12	Journal			

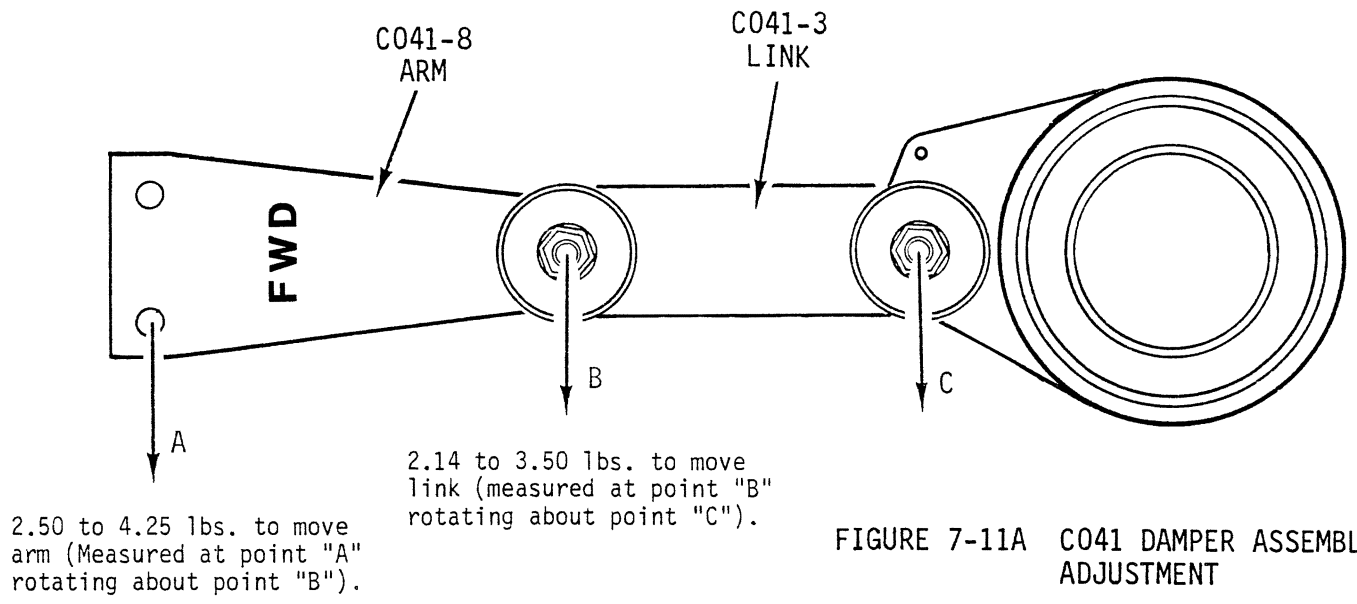

FIGURE 7-11A C041 DAMPER ASSEMBLY ADJUSTMENT

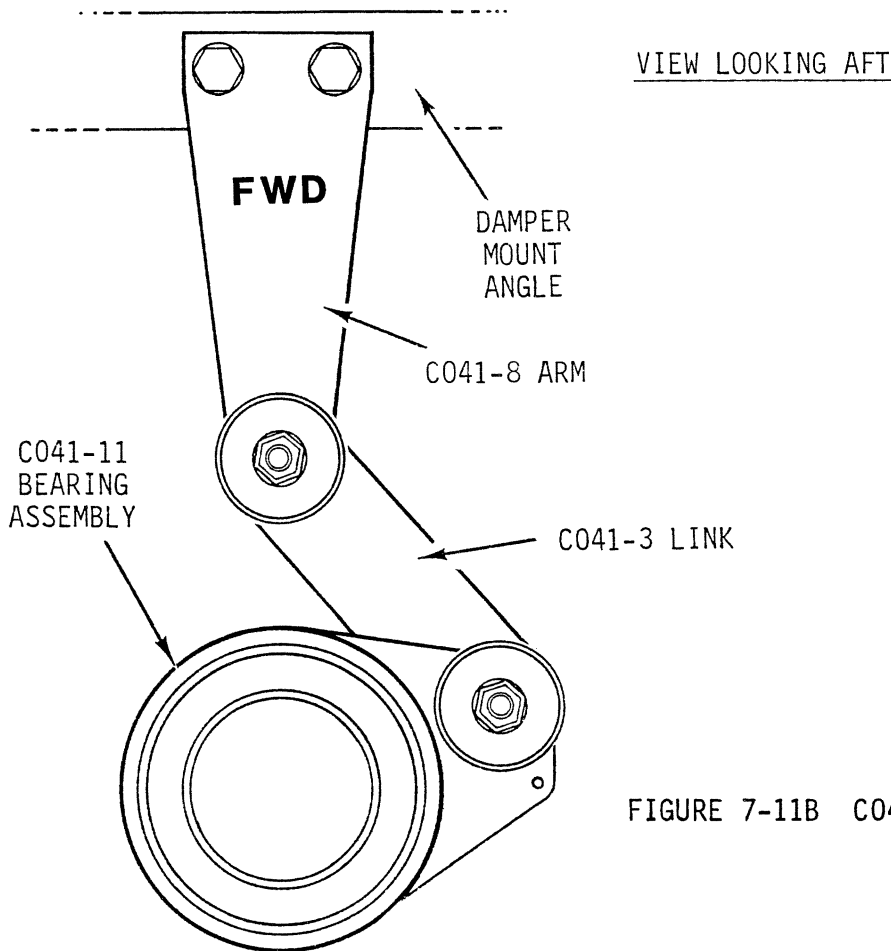

FIGURE 7-11B C041 DAMPER ORIENTATION

7.321 Adjustment of Damper Friction (cont'd)

- f) Refer to Figure 7-11A. Hold C041-3 link and attach a spring scale or dead weight to one bolt hole in C041-8 arm. It should take 2.50 to 4.25 lb to move arm. Check bearing housing pivot friction with spring scale or dead weight at link bolt. It should take 2.14 to 3.50 lb to move link.

If drag is less than specified, check C041-6 spring washer and bend washer until it has a total height of 0.065 - 0.078 inch. If spring washer is correct height, but drag is still too low, lap end of A105-12 journal. If drag is greater than specified, flatten spring washer slightly.

CAUTION

DO NOT ADJUST DAMPER DRAG BY CHANGING BOLT TORQUE.

- g) Torque MS21042L4 nut per Section 1.320 and recheck damper frictions per Step f). Install B330-13 palnuts and torque stripe.
- h) Install tail rotor drive shaft per Section 7.320.

7.330 Intermediate Flex Plate Installation and Shimming

Measurements taken with intermediate flex plate removed.

- a) Engage clutch actuator.
- b) Rotate drive flanges of tail rotor shaft and C195 yoke horizontal.
- c) Insert NAS1304 bolt through tail rotor shaft and C195 aft clutch yoke at 9 o'clock position. Measure and record gap between flanges at 3 o'clock position. Remove bolt.
- d) Insert bolt at 3 o'clock position. Measure and record gap at 9 o'clock position. Measurements in sequence C and D are Measurement 1.
- e) Remove bolt and rotate tail rotor shaft 180 degrees. Repeat steps C & D. This will be Measurement 2.

NOTE

Measurement 1 and 2 should be similar. If measurements are not similar, one or both yokes are bent.

- f) Determine difference between 3 o'clock and 9 o'clock gap in Measurement 1. Determine difference between 3 o'clock and 9 o'clock gap in Measurement 2.

7.330 Intermediate Flex Plate Installation and Shimming (cont'd)

- g) Use following formula to obtain the calculated dimensions for proper shimming required at the intermediate flex plate.

NOTE

Use the measurement with the smaller difference between 3 and 9 o'clock readings.

9 o'clock reading + 3 o'clock reading	=	
Divide above sum by 2	=	
Subtract *		*
Calculated Dimension	=	

*Average thickness of the A947-2 flex plate measured at the bonded washers.

Shim as required per Table 7-1.

- h) Reinstall the flex plate using the shims determined above. Torque the attach bolts per Section 1.320. Install palnut and torque stripe. Refer to Figure 7-4.

7.340 Checking Tail Rotor Drive Shaft Runout

The runout check described below is to prevent excessive runout on the tail rotor drive shaft which can cause a failure in the intermediate flex coupling or damper assembly.

- a) Remove all the tailcone inspection covers on the tailcone right side. Engage the clutch.
- b) Assemble the Robinson Tool Number MT260-6 tool and a suitable dial indicator.

NOTE

The dial indicator included in the Robinson MT122 bolt stretch gauge is recommended for this tool.

7.340 Checking Tail Rotor Drive Shaft Runout (cont'd)

- c) Insert the dial indicator through the inspection hole farthest aft on the right side of the tailcone. Press the dial indicator firmly against the tailcone when the extension is riding on the drive shaft.
- d) Have someone rotate the drive shaft at the C166 clutch shaft at least three full revolutions. The indicator may vary somewhat with each revolution so it will be necessary to take an average.
- e) Repeat procedure in steps C & D at the next inspection hole forward.
- f) Remove the extension from the MT260 tool and, using the longer extensions, check the drive shaft at each of the other two inspection holes.
- g) The maximum amount of runout at any of the locations must not exceed 0.025 inch. If the runout is excessive, the drive shaft must be repaired or replaced.

7.350 Two-Piece Tail Rotor Drive Shaft

- a) The two-piece tail rotor drive shaft consists of one C196-1 shaft, one C195-5 yoke, one C041-1 damper assembly, two C191-2 clamping blocks and associated hardware. See Figure 7-12A .
- b) The C041-1 damper bearing assembly is field replaceable; refer to Figures 7-12A and 7-12B for appropriate dimensional criteria.
- c) The D224-1 drive shaft is produced in one length only.

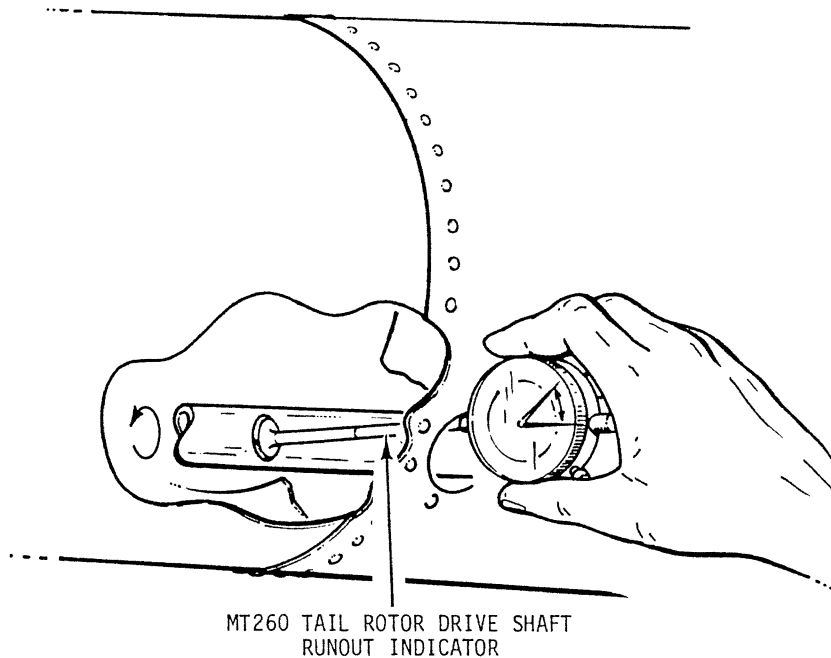

FIGURE 7-12 TAIL ROTOR DRIVE SHAFT RUNOUT CHECK

Calculated dimension from § 7.330 (g)	<u>Total shims required between flex plate and clutch shaft's aft C195 yoke</u>	<u>Total shims required between flex plate and TR drive shaft's forward yoke</u>
0.137 inch or more	Measurement is over limit and a longer C195 yoke is required.	Measurement is over limit and a longer C195 yoke is required.
0.136 inch to 0.107 inch	1 each NAS1149F0463P washer substituted for NAS1149F0432P (required 2 places)	1 each NAS1149F0463P washer (required 2 places)
0.106 inch to 0.077 inch	1 each NAS1149F0432P washer (required 2 places)	1 each NAS1149F0463P washer (required 2 places)
0.076 inch to 0.047 inch	1 each NAS1149F0432P washer (required 2 places)	1 each NAS1149F0432P washer (required 2 places)
0.046 inch to 0.017 inch	1 each NAS1149F0432P washer (required 2 places)	No washers for shimming
0.016 inch or less	Shorter C195 yoke is required	Shorter C195 yoke is required

CAUTION

There must be an NAS1149F0432P or NAS1149F0463P washer between each arm of C195 yoke and A947-2 flex plate.

TABLE 7-1 A947-2 INTERMEDIATE FLEX PLATE SHIM TABLE

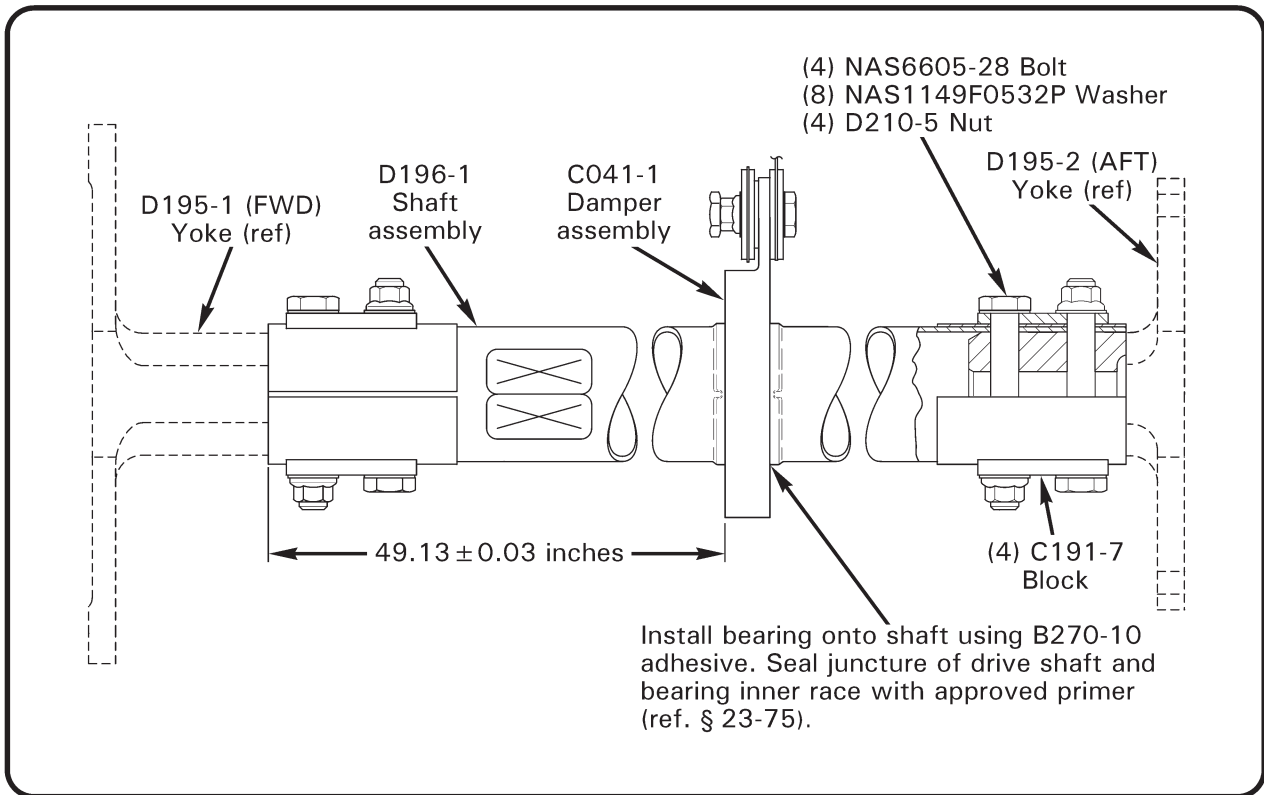

FIGURE 7-12A D196-1 TAIL ROTOR DRIVE SHAFT

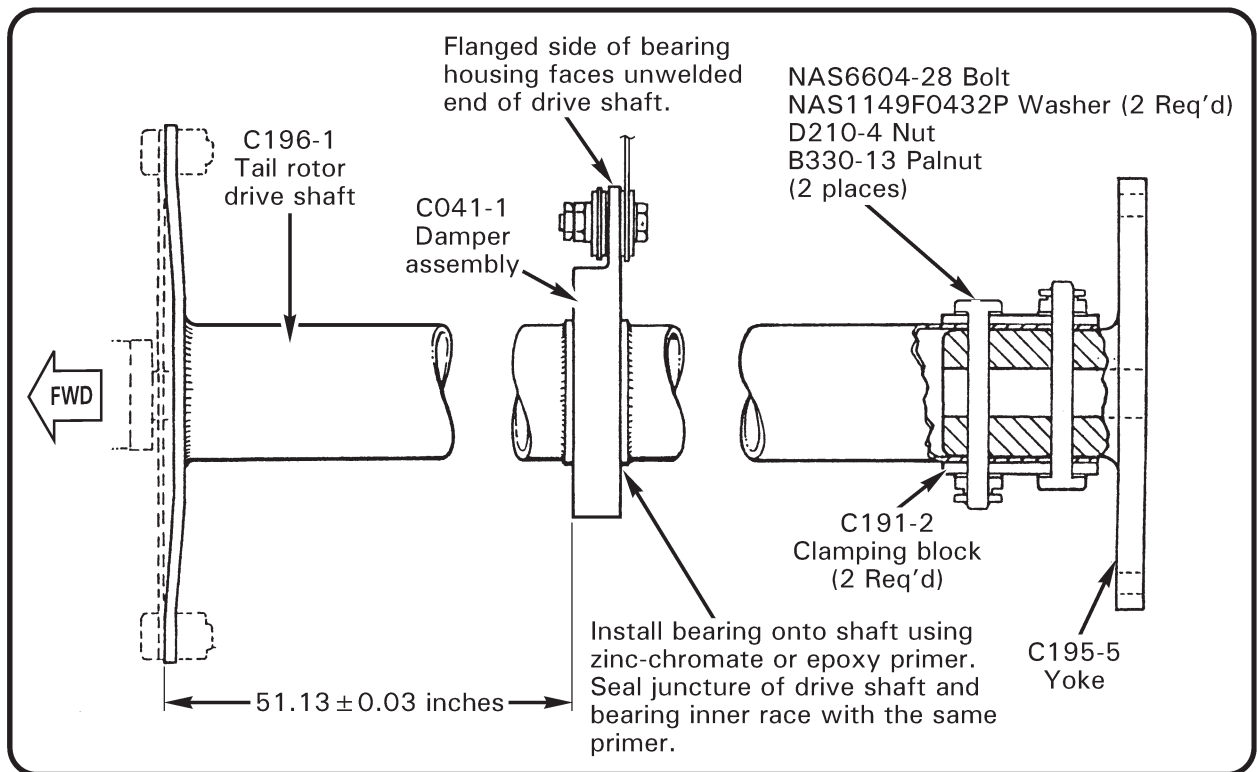

FIGURE 7-12B C196-1 TAIL ROTOR DRIVE SHAFT

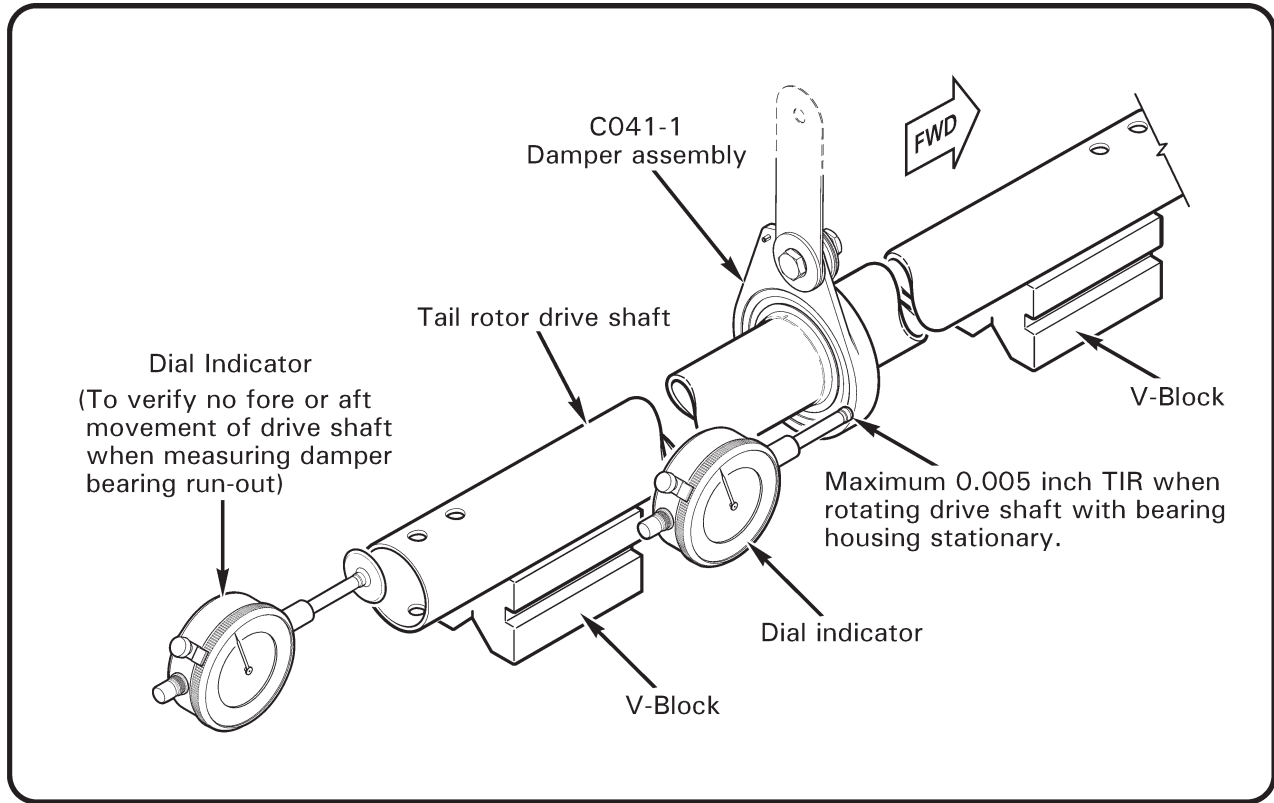

FIGURE 7-12C DAMPER BEARING RUN-OUT INSPECTION

Intentionally Blank

7.400 TAIL ROTOR GEARBOX

7.410 Tail Rotor Gearbox Removal

- a) Mark the tail rotor hub and blades and tail rotor pitch links to their respective pitch control arms before disassembly. This will facilitate reinstallation and eliminate re-rigging the tail rotor if push-pull tube lengths are not altered.
- b) Remove the tail rotor hub and blades. Leave the pitch control links attached to the tail rotor blades.
- c) Disconnect the A120 bellcrank from the push-pull tube.
- d) Remove A120-3 bellcrank and pitch control from tail rotor gearbox. Disconnect A120-3 bellcrank attach bolt from the gearbox output cartridge and slide pitch control, with the bellcrank attached, off the gearbox output shaft. Reassemble bellcrank hardware to bellcrank.
- e) Working through upper aft inspection hole of tailcone, disconnect the aft flex coupling from gearbox input shaft flange.

CAUTION

Drive shaft must be supported through the upper aft inspection hole to prevent damage to flex plate and drive shaft. Do not leave any loose hardware inside the tailcone.

- f) Disconnect chip detector wire at bottom of gearbox.
- g) Cut the safety wire and remove four bolts holding the tail rotor gearbox to the tailcone. Careful handling of gearbox on removal is required to prevent damage to input shaft or the threads on the output shaft.

7.420 Tail Rotor Gearbox Installation

- a) Install the tail rotor gearbox to the tailcone and torque four cap screws per Section 1.330. Safety wire screws in pairs with 0.032 inch diameter safety wire.
- b) Connect the chip detector wire at the tail rotor gearbox.
- c) Connect flex plate to tail rotor gearbox. Torque bolts to per Section 1.320.
- d) Tail rotor drive shaft support can now be removed.

7.420 Tail Rotor Gearbox Installation (cont'd)

- e) Check intermediate flex plate shimming per Section 7.330.
- f) Install the tail rotor pitch control and bellcrank. Re-shim per Section 8.560 if original stack lost or binding occurs when assembly is moved.
- g) Reconnect C121-17 push-pull tube to aft bellcrank.
- h) Install tail rotor hub and blades.
- i) Connect pitch links to the pitch control arms.
- j) Ensure all bolts are torqued per Section 1.300.

7.430 Tail Rotor Gearbox Chip Indicator

Use the following procedure to drain the gearbox and inspect the lubricant and chip detector for chips.

- a) Use a clean container to catch tail rotor gearbox oil.
- b) Cut safety wire on chip detector and disconnect the electrical wires. Remove chip detector and drain oil.
- c) Strain the oil and inspect any particles found in the oil or on the chip detector. Examine the particles for size; any particles larger (0.09 inch long or 0.02 inch wide) than fine fuzz (normal wear) should be identified as ferrous or non-ferrous by using a magnet. If numerous particles are found and the next running of the gearbox produces more particles, a tail rotor gearbox failure may be impending and a tail rotor gearbox overhaul is required.
- d) See Section 1.130 for flushing and refilling of the gearbox.

7.440 Tail Rotor Gearbox Output Shaft Seal Replacement (ref Figure 7-13)

- a) Remove tail rotor and pitch control bearing per Section 7.410.

NOTE

Mark all attachments for proper re-assembly.

- b) Cut the safety wire and remove four MS20074-04-06 bolts securing the C112-2 cap.
- c) Slide C112-2 cap over the output shaft and remove the seal and 'O'-ring.

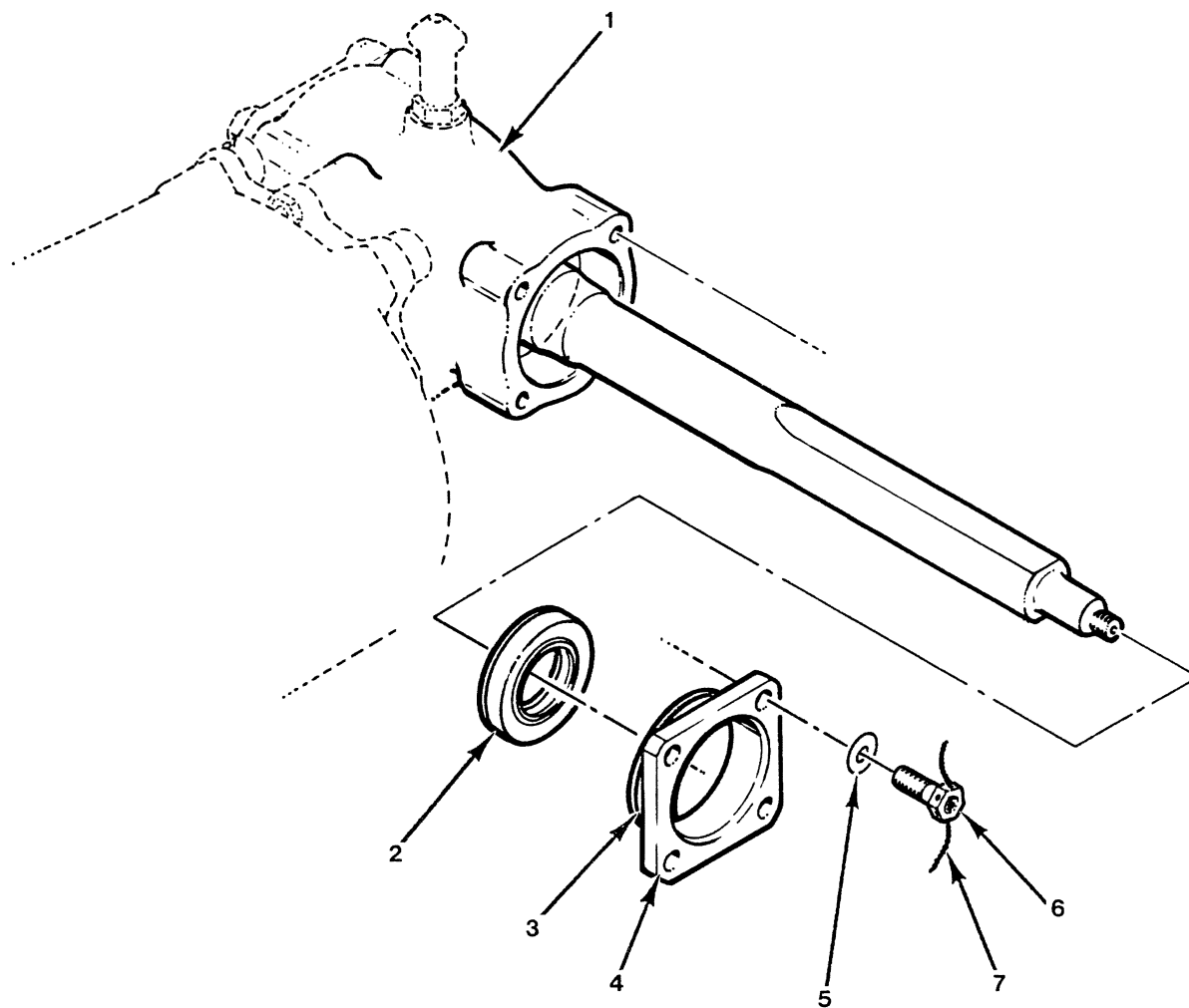

FIGURE 7-13 TAIL ROTOR GEARBOX OUTPUT SHAFT SEAL REPLACEMENT

<u>NUMBER</u>	<u>PART NUMBER</u>	<u>DESCRIPTION</u>
1	C109-1	Housing
2	C966-2	Seal
3	C215-133	O-Ring
4	C112-2	Cap
5	AN960-416L	Washer
6	MS20074-04-06	Bolt
7	-	0.032 in. dia Safety Wire

7.440 Tail Rotor Gearbox Output Shaft Seal Replacement (cont'd)**CAUTION**

Be careful not to lose or change shim stack-up between the cap and the gearbox. Any change to the shim stack-up will change factory-set preload drag.

- d) Carefully clean seal seating surface and O-ring groove and dry.
- e) Press a new C966-2 seal into the cap bore 0.160 inches below the external surface with seal lip toward the gearbox. Lubricate a new C215-133 O-ring with A257-2 gear oil and install in groove in cap.
- f) Lubricate the seal seating area of the output shaft with A257-2 gear oil.
- g) Slide the cap over the output shaft and reinstall on the gearbox. Torque the four bolts to 60 in.-lb and safety wire in pairs with 0.032 inch diameter safety wire.
- h) Reassemble pitch control bearing and tail rotor per Section 8.562.

7.450 Tail Rotor Gearbox Input Shaft Seal Replacement (Ref Figure 7-13A)**NOTE**

It is not necessary to remove pitch control assembly and tail rotor for this procedure.

- a) Remove gearbox from tailcone per Section 7.410.
- b) Remove MS24665-210 cotter pin from the nut at the center of C116-1 input yoke.
- c) Place the gearbox assembly on a bench and put a 2-inch thick wood block between one arm of the C116-1 yoke and the gearbox housing.
- d) Remove the AN320-8 castellated nut and remove the yoke.
- e) Cut the safety wire on and remove four MS20074-04-06 bolts.
- f) Remove C112-1 cap. Be sure not to lose the C141-2 washer that is located between cap and bearing. Remove the O-ring.
- g) Press out old seal and clean the seal seating surface and O-ring groove.

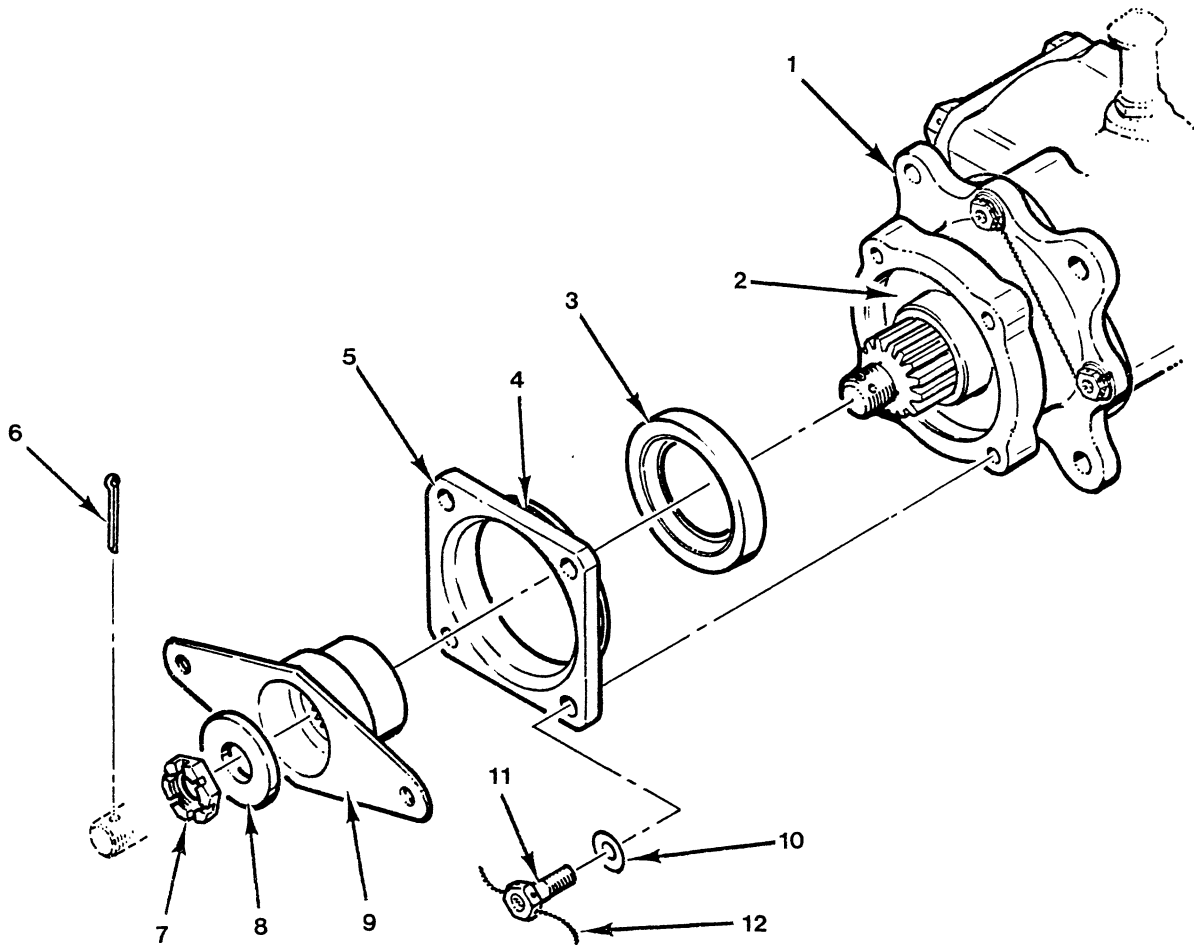

FIGURE 7-13A TAIL ROTOR GEARBOX INPUT SHAFT SEAL REPLACEMENT

<u>NUMBER</u>	<u>PART NUMBER</u>	<u>DESCRIPTION</u>
1	C110-1	Input Cartridge
2	C141-2	Washer (between cap & input cartridge)
3	A966-3	Seal
4	C215-140	O-Ring
5	C112-1	Cap
6	MS24665-210	Cotter Pin
7	AN320-8	Nut
8	A141-10	Washer
9	C116-1	Yoke
10	AN960-416L	Washer
11	MS20074-04-06	Bolt
12	-	0.032 in. dia Safety Wire

7.450 Tail Rotor Gearbox Input Shaft Seal Replacement (cont'd)

- h) Press a new A966-3 seal into cap 0.250-inch from external surface with seal lip toward gearbox. Lubricate a new C215-140 O-ring with A257-2 gear oil and install in groove in cap.
- i) Install C141-2 washer and cap into C110-1 cartridge. Install four MS20074-04-06 bolts with AN960-416L washers under head. Torque to 60 in.-lb and safety wire in pairs with 0.032-inch diameter safety wire.
- j) Install C116-1 yoke, A141-10 washer, and AN320-8 nut onto gear shaft.
- k) Hold the gearbox and support yoke flange with a 2-inch wooden block.
- l) Torque the nut to 290-410 in.-lb and secure with a new MS24665-210 cotter pin.
- m) Install gearbox per Section 7.420.

7.500 ACTUATOR ASSEMBLY

7.510 Actuator Removal

- a) Remove aft cowling assembly.
- b) Disengage clutch to its fullest disengaged position.
- c) Remove cooling fan and scroll per Section 6.200.
- d) Put a six-inch wooden block under the clutch shaft just forward of the upper sheave on the horizontal firewall. This keeps the sheave from drooping and prevents damage to the forward flex plate (see Figure 7-8).
- e) Disconnect two wiring connections to actuator.
- f) Disconnect the clutch lateral centering strut from the upper frame.
- g) Remove the upper NAS6605 and lower NAS6604 bolts and remove actuator.

7.520 Actuator Installation

- a) Inspect upper and lower clutch actuator bearings per Section 2.140.B.
- b) Position actuator for installation.
- c) Install lower attach bolt with head facing aft. Use one AN960-416L washer under bolt head and one AN960-416 washer under nut. Torque per Section 1.320, install palnut and torque stripe.

7.520 Actuator Installation

- d) Connect actuator gearmotor housing to C184 bearing per Figure 7-14. Standard torque bolt per Section 1.320, install & torque palnut, and torque stripe per Figure 2-1.
- e) If installed, remove block(s) supporting clutch assembly.
- f) Connect clutch lateral centering strut, standard torque bolt per Section 1.320, install palnut, and torque stripe per Figure 2-1.
- g) Install fanwheel and scroll per Section 6.220.
- h) Connect gearmotor and switch harness electrical leads and ty-rap as required.
- i) Balance fanwheel per Section 6.240.
- j) Install aft cowling.

CAUTION

Do not engage actuator without scroll installed.

7.530 Actuator Gearmotor Replacement

Actuator gearmotor can be replaced with actuator on helicopter.

1. Disconnect gearmotor electrical leads.
2. Cut safety wire from four gearmotor attach screws.
3. Remove screws, using care not to drop them in V-belt drive.
4. Slowly slide gearmotor assembly from housing. An unscrewing motion may be necessary.
5. Lightly lubricate worm gear on new gearmotor assembly with A257-1 grease before installing. Install O-ring onto gearmotor nose.
6. Install new gearmotor into housing with wire leads pointing outboard. Verify no gap exists between housing and motor mounting flange.
7. Install and tighten (4) mounting screws into housing and safety in pairs with 0.032 inch diameter safety wire.
8. Connect gearmotor electrical leads. Engage clutch, listen for binding, and verify actuator shuts off after column springs yield (indicated by "popping" sound).

CAUTION

If gearmotor electrical pins are reversed in connector, gearmotor will operate backward and down-limit switch and spring switches **WILL NOT** shut off power; damage to actuator and drive belts can occur.

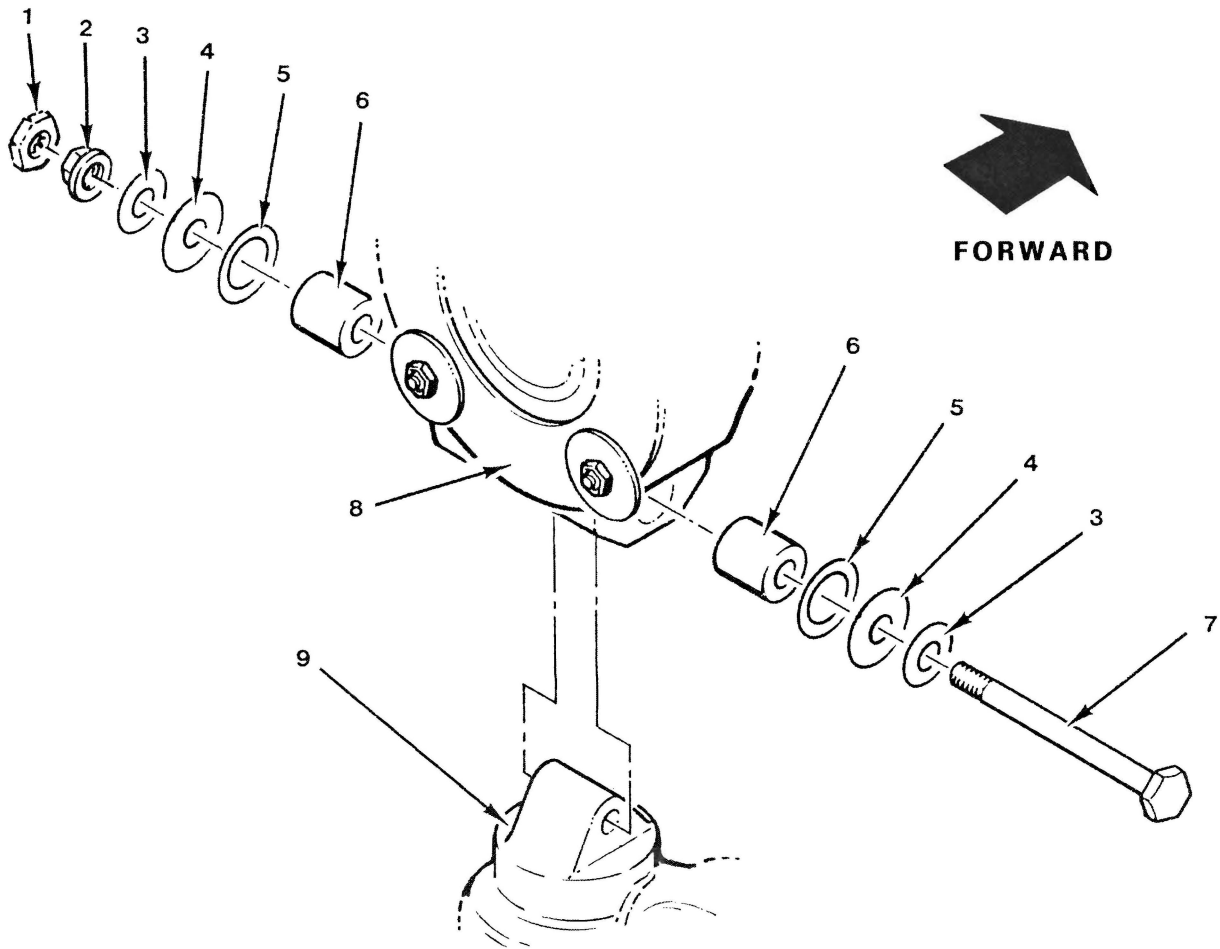

FIGURE 7-14 ACTUATOR ASSEMBLY INSTALLATION

<u>NUMBER</u>	<u>PART NUMBER</u>	<u>DESCRIPTION</u>
1	B330-16	PALNUT
2	MS21042L5	NUT
3	C141-1	WASHER
4	AN960-516L	WASHER
5	CA214-8	THRUST WASHER
6	C105-2	JOURNAL
7	NAS6605-38	BOLT
8	C184-2	UPPER BEARING ASSEMBLY
9	C051-1	ACTUATOR ASSEMBLY

7.540 Actuator Adjustment

1. Engaged Limit

The actuator engaged limit is determined by column springs which control drive belt tension. Column springs may only be adjusted by the factory.

2. Disengaged (Down-Limit) Adjustment

The down-limit switch is activated by the down-limit stop screw, which can be adjusted using long 3/8-inch open-end (MT357-6) and 1/4-inch box-end (MT357-7) wrenches. Adjust down-limit stop screw to maintain proper belt deflection per Section 7.282 with actuator fully disengaged. Minimum clearance between screw heads at scissors is 0.015 inch per Figure 7-15.

3. Maximum Extension

Maximum engaged extension is 1.60 inches, measured as shown in Figure 7-15. The extension-limit switch activates at 1.50/1.60 inches extension. Drive V-belts must be replaced when maximum extension is encountered.

7.550 Switch and Fuse Replacement

7.551 Switch Replacement

1. Remove actuator per Section 7.510.

NOTE

Switches may be replaced as a complete switches & harness assembly, or replaced individually by installing heat shrink and soldering wire connections.

2. Remove desired switch by removing attaching screw, nut, washer, and spacing washers between switch and plate.

NOTE

Spacing washers may be bonded to new switch(es) to ease reassembly.

3. Replace complete switches and wire harness assembly or, if installing a single switch, cut wires from faulty switch as close to switches as possible.
4. Slide new heat shrink over each cut wire. Solder wires to switch and install heat shrink over solder connection.
5. Reassemble switch(es) to plate. Two spacing washers are installed between switch and plate at each attach screw and one under nut. Do not over tighten screws or plastic switch housing may crack.
6. Reinstall actuator per Section 7.520.

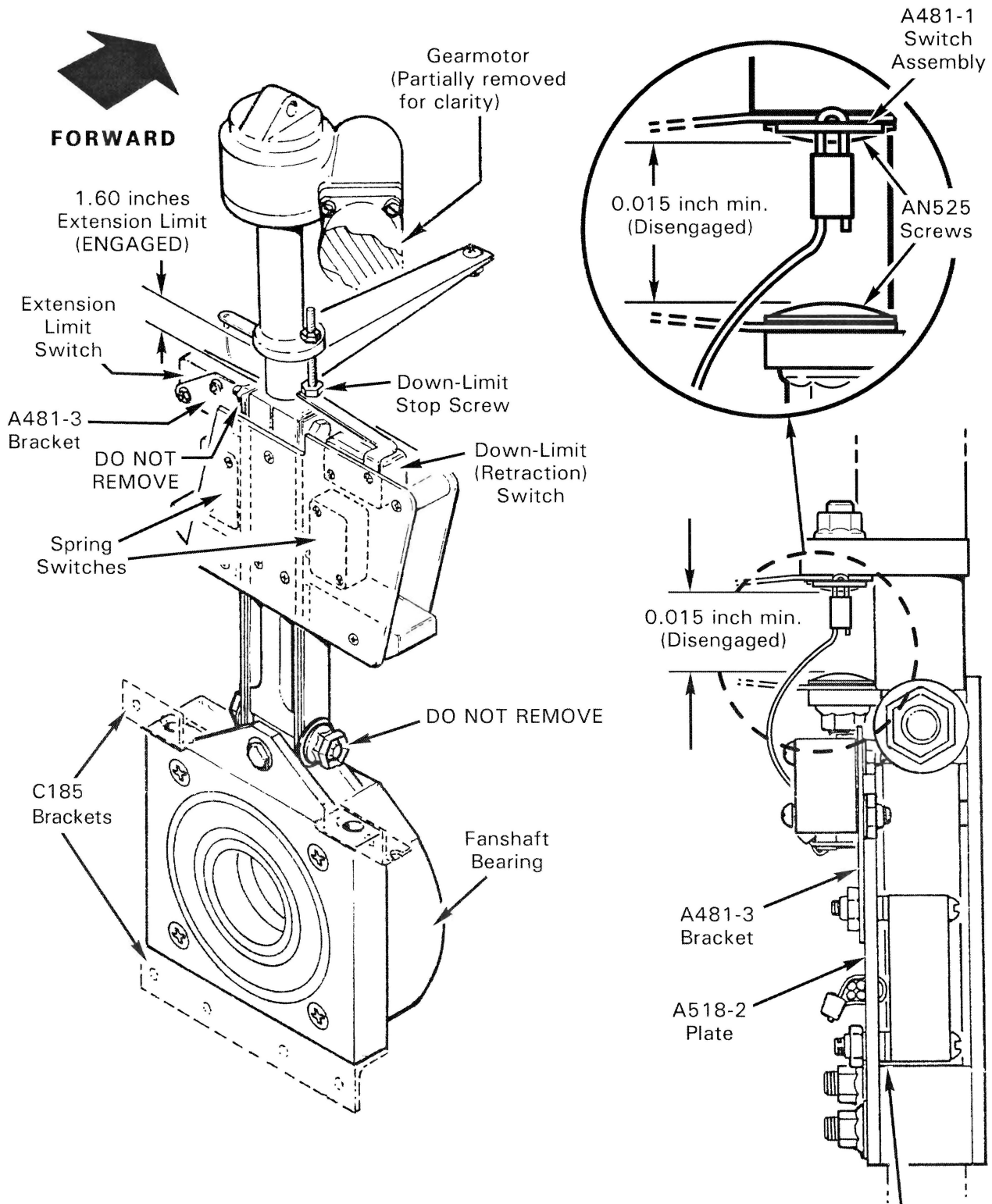

FIGURE 7-15 ACTUATOR LIMIT SWITCHES

2 required on each screw between A513-2 plate and spring switches)
(VIEW FROM LEFT SIDE)

7.551 Switch Replacement (cont'd)

- d) Slide heat shrink over each cut wire. Solder wires to switch and install heat shrink over solder connection.
- e) Reassemble switch(es) to plate. Two spacing washers are installed between switch and plate at each attach screw and one under nut. Do not overtighten screws or plastic switch housing may crack.
- f) Reinstall actuator on helicopter per Section 7.520.

7.552 Fuse Replacement

An in-line fuse holder is installed in the clutch actuator motor power circuit. R44 S/N 0106 & prior have the fuse holder ty-rapped in the wire bundle above the horizontal firewall in the main rotor gearbox compartment. On R44 S/N 0107 and subsequent the fuse holder is mounted on the test switch panel. Replace fuse with 3.0 amp (AGC 3.0) fuse.

7.600 ROTOR BRAKE**7.610 Rotor Brake Removal**

- a) Remove tailcone cowling. Remove the forward flex plate. Mark and record any shim washers installed between the flex plate and the input yoke to the main rotor gearbox or the yoke on the clutch shaft.
- b) Remove the cotter pin and the nut securing the input yoke on the main rotor gearbox. Remove the yoke. Disconnect the spring from the firewall angle.
- c) Remove the cable pulley from the lever. Disconnect the wiring to the micro switch at the three-pin connector.
- d) Cut and remove the safety wire, then remove the three bolts securing the rotor brake. Record the position of the two small and one long spacers for reinstallation. Remove the rotor brake assembly.

7.620 Rotor Brake Installation

- a) Place the rotor brake assembly over the splined input pinion shaft of the main rotor gearbox.
- b) Place one each of the two small (C130-3) spacers in place between the rotor brake assembly and the pinion end cover. Install one each AN960-416L washer on the three NAS1352-4H30P bolts. Insert the first bolt through the rotor brake assembly and the A130-41 spacer. Insert the second bolt through the Hall Effect sender plate, rotor brake assembly and the A130-41 spacer. Place one AN960-416 washer between the Hall Effect sender plate and the rotor brake bracket.

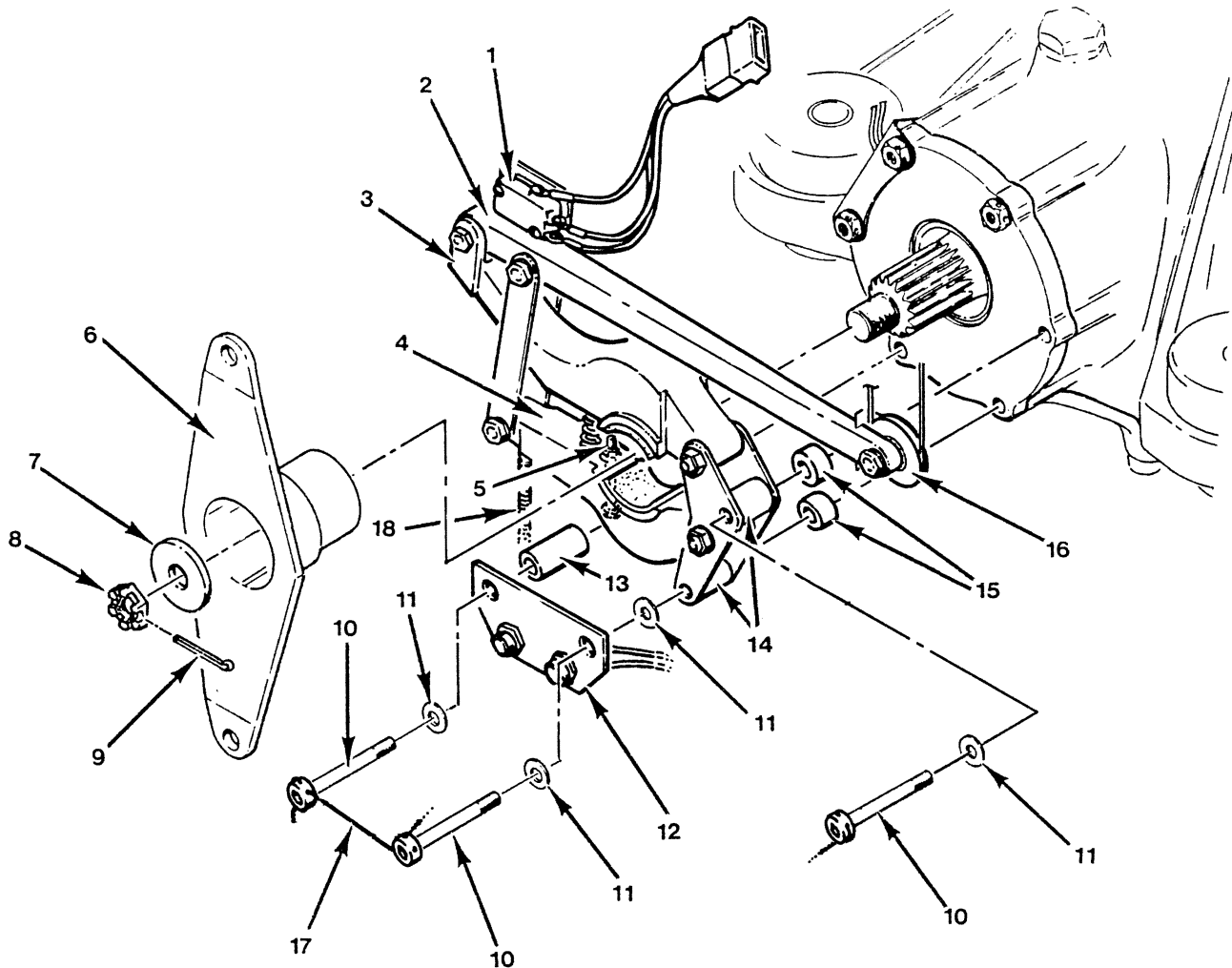

FIGURE 7-16 ROTOR BRAKE INSTALLATION

<u>NUMBER</u>	<u>PART NUMBER</u>	<u>DESCRIPTION</u>	<u>NUMBER</u>	<u>PART NUMBER</u>	<u>DESCRIPTION</u>
1	-	Micro Switch	12	D114-1	Bracket
2	D112-1	Lever	13	C130-4	Spacer
3	D110-1	Arm Assembly	14	A130-41	Spacer
4	D123-1	Arm Assembly	15	C130-3	Spacer
5	NAS428-3-14	Bolt	16	AN210-1A	Pulley
	NAS1291-3	Nut	17	-	0.032 in. dia Safety Wire
6	C908-1	Yoke Assembly	18	E0240-037-3500S	Spring
7	C141-10	Washer			
8	AN320-8	Nut			
9	MS24665-210	Cotter Pin			
10	NAS1352-4H30P	Screw			
11	AN960-416	Washer			

7.620 Rotor Brake Installation (cont'd)

- c) Insert the third bolt through the Hall Effect sender plate and the long C130-4 spacer. Finger tighten the three bolts into the gearbox, then torque the bolts to 120 in.-lb and safety with 0.032 inch diameter safety wire. Attach the spring to the firewall angle.
- d) Place the C908-1 yoke on the pinion shaft. Install one each C141-10 washer and AN320-8 nut on the pinion shaft. Torque the nut to a minimum of 290 in.-lbs. Align the castellations on the nut with the hole through the pinion shaft. Do not exceed 410 in.-lbs. Install one MS24665-210 cotter pin.
- e) Set the Hall Effect sender-to-magnet gap per Section 7.141.
- f) Attach the cable pulley to the lever. Reconnect the wiring to the micro switch at the three-pin connector.
- g) With the brake engaged, adjust the gap between the NAS428-3-14 bolthead on the D123-1 arm and the C130-4 spacer to 0.030-0.035 inch. Lock the adjustment by tightening the MS21042L3 nut (see Figure 7-16A).
- h) With the brake in the released position, measure the gap between the D112-1 lever and the D110-1 arm assembly. The gap measurement should be 0.030 - 0.170 inch. Adjust the length of the bead chain as required to obtain proper gap.
- i) Adjust the micro switch to open and close at a gap of 0.20 - 0.30 inch between the D112-1 lever and the D110-1 arm.
- j) Install the forward flex plate. Check the clutch sheave alignment per Section 7.230. Check the intermediate flex plate installation and shimming per Section 7.330.

7.630 Rotor Brake Pad Replacement

- a) Minimum pad thickness is 0.030 inch.
- b) Brake pad replacement is accomplished by replacing the D110-1 and D123-1 arm assemblies.

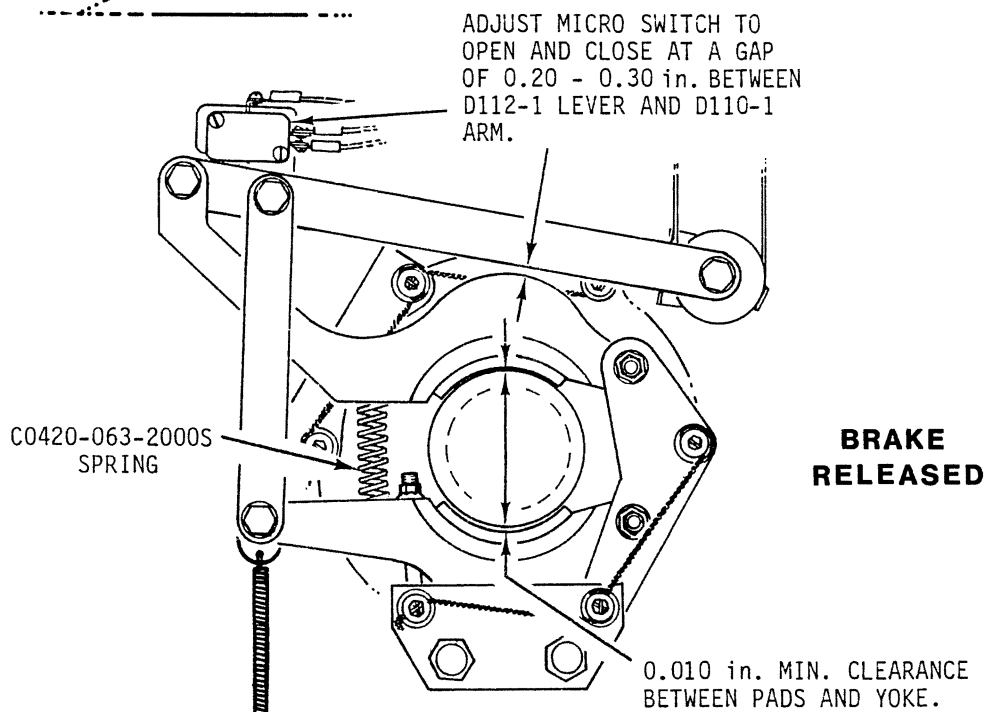
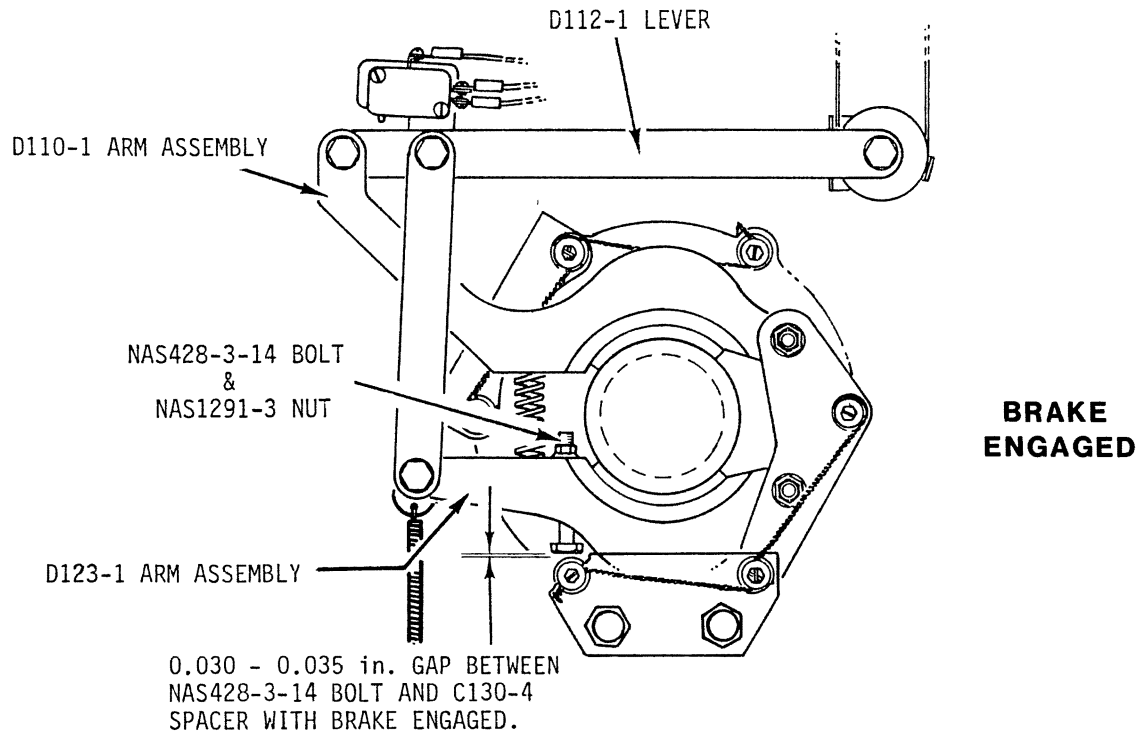

FIGURE 7-16A
ROTOR BRAKE ADJUSTMENTS AND CLEARANCES

CHAPTER 8
FLIGHT CONTROLS

<u>Section</u>	<u>Title</u>	<u>Page</u>
8.000	Flight Controls	8.1
8.001	Introduction	8.1
8.002	Description	8.1
8.003	Hydraulic Flight Controls	8.1
8.004	Hydraulic Pump Description	8.2
8.005	Hydraulic Reservoir Description	8.2
8.006	Hydraulic Servo Description	8.2
8.100	Cyclic Controls	8.3B
8.110	Cyclic Assembly	8.3B
8.111	Cyclic Assembly Removal	8.3B
8.112	Cyclic Assembly Installation	8.5
8.120	Cyclic Grip Assembly	8.6
8.121	Cyclic Grip Assembly Removal	8.7
8.122	Cyclic Grip Assembly Installation	8.10
8.130	Longitudinal Cyclic Trim Elastic Cords (electric trim systems only)	8.11
8.131	Elastic Cord Removal	8.13
8.132	Elastic Cord Installation	8.14
8.140	Lateral & Longitudinal Cyclic Trim Assemblies (electric trim systems only)	8.15
8.141	Lateral Cyclic Trim Assembly Removal	8.15
8.142	Lateral Cyclic Trim Assembly Installation	8.16
8.143	Longitudinal Cyclic Trim Assembly Removal	8.16
8.144	Longitudinal Cyclic Trim Assembly Installation	8.17
8.150	Cyclic Friction Assembly	8.19
8.161	Cyclic Friction Adjustment	8.19
8.160	C121-7 Push-Pull Tube (electric trim systems only)	8.19
8.161	C121-7 Push-Pull Tube Removal	8.19
8.162	C121-7 Push-Pull Tube Inspection / Repair	8.20
8.163	C121-7 Push-Pull Tube Sleeve Installation	8.20

CHAPTER 8

FLIGHT CONTROLS (Continued)

<u>Section</u>	<u>Title</u>	<u>Page</u>
8.164	C121-7 Push-Pull Tube Sleeve Inspection	8.21
8.165	C121-7 Push-Pull Tube Installation	8.21
8.200	Collective Control	8.24
8.210	Collective Stick Assembly	8.24
8.211	Collective Stick Removal	8.24
8.212	Collective Stick Installation	8.24
8.213	Pilot-Adjustable Collective Friction Adjustment	8.28
8.214	Fixed Collective Friction Adjustment	8.28
8.220	Collective Spring Assembly (manual controls only)	8.28
8.221	Collective Spring Removal & Servicing	8.28
8.222	Collective Spring Installation	8.30
8.223	Collective Spring Adjustment	8.31
8.230	RPM Governor System	8.32
8.231	Governor Controller Removal	8.32
8.232	Governor Controller Installation	8.32
8.233	Governor Assembly Removal	8.33
8.234	Governor Assembly Installation	8.33
8.239	Governor Troubleshooting	8.33A
8.300	Jackshaft and Support Struts	8.34
8.310	Jackshaft	8.34
8.311	Jackshaft Removal	8.34
8.312	Jackshaft Installation	8.34
8.320	Strut Assembly (Jackshaft Support)	8.34
8.321	Jackshaft Strut Removal	8.34
8.322	Jackshaft Strut Installation	8.35
8.400	Swashplate and Main Rotor Pitch Links	8.38
8.410	Swashplate	8.38
8.411	Swashplate Removal	8.38
8.412	Swashplate Installation	8.38

CHAPTER 8

FLIGHT CONTROLS (Continued)

<u>Section</u>	<u>Title</u>	<u>Page</u>
	8.413 Swashplate Tilting Friction Adjustment	8.44
8.500	Tail Rotor Controls	8.44
8.510	Tail Rotor Pedals	8.44
	8.511 Tail Rotor Pedal Removal	8.44
	8.512 Tail Rotor Pedal Installation	8.45
8.520	C317 Bellcranks	8.46
	8.521 C317-2 Lower Forward Bellcrank Removal	8.46
	8.522 C317-2 Lower Forward Bellcrank Installation	8.46
	8.523 C317-1 Lower Aft Bellcrank Removal	8.48
	8.524 C317-1 Lower Aft Bellcrank Installation	8.49
8.530	C316-1 Bellcranks	8.49
	8.531 Bellcrank Removal	8.49
	8.532 Bellcrank Installation	8.50
8.540	A331-4 Intermediate Bellcrank	8.50
	8.541 Bellcrank Removal	8.50
	8.542 Bellcrank Installation	8.50
8.550	A120-3 Aft Bellcrank	8.51
	8.551 Bellcrank Removal	8.51
	8.552 Bellcrank Installation	8.51
8.560	C031-1 Pitch Control	8.51
	8.561 Pitch Control Removal	8.51
	8.562 Pitch Control Installation	8.51
8.570	Tail Rotor Pitch Links	8.52
	8.571 Tail Rotor Pitch Link Removal	8.52
	8.572 Tail Rotor Pitch Link Installation	8.52
8.600	C203 Yoke and A205 Fork Assemblies	8.54
	8.610 Bearing Removal	8.54
	8.615 C648-2 Bearing Installation	8.54
	8.620 B115-1 Bearing Installation	8.54

CHAPTER 8

FLIGHT CONTROLS (Continued)

<u>Section</u>	<u>Title</u>	<u>Page</u>
8.700	Hydraulic Flight Controls	8.61
8.710	Hydraulic Reservoir Removal	8.61
8.720	Hydraulic Reservoir Installation	8.61
8.730	Hydraulic Pump Removal	8.62
8.740	Hydraulic Pump Installation	8.63
8.750	Hydraulic Servo Removal	8.64
8.760	Hydraulic Servo Installation	8.65

CHAPTER 8

FLIGHT CONTROLS

8.000 Flight Controls

8.001 Introduction

This section covers removal and installation procedures for cyclic controls, collective controls, tail rotor controls, and related components.

WARNING

Assembly of flight controls is critical and requires inspection by a qualified person. If a second person is not available, the installer must take a 5-minute break prior to inspecting flight control connections he has assembled.

8.002 Description (see Figures 8-1 and 8-2)

Dual controls, which are removable on the left side, are standard equipment. All primary controls are actuated through push-pull tubes and bellcranks. Bearings used throughout the control system are either sealed ball bearings or have self-lubricated Teflon® liners.

R44 flight controls operate conventionally. The cyclic stick appears different, but the grip moves as in other helicopters. The cyclic grip is free to move vertically allowing the pilot to rest his forearm on his knee if he chooses. Electric trim-equipped aircraft include strain gages mounted to the cyclic stick to sense control forces, and electric trim motors at the base of the stick which automatically minimize these forces.

The collective stick is conventional with a twist grip throttle. When the collective control is raised, the engine throttle is opened automatically by an interconnecting linkage. Additionally, an electronic throttle governor adjusts throttle position to maintain RPM.

8.003 Hydraulic Flight Controls

The optional hydraulic flight control system consists of a pump mounted to the main rotor gearbox, a servo at each of the three push-pull control tubes supporting the main rotor swashplate, a reservoir assembly, interconnecting lines, A257-15 hydraulic fluid (see § 23-78). An elastic cord replaces the collective trim spring and balances the weight of the collective stick.

Figure 8-1A shows the hydraulic control system. A schematic diagram of the system is given in Figure 8-1B.

WARNING

Except as instructed in this manual, service on the hydraulic system is limited to component removal and replacement.

CAUTION

Cleanliness of hydraulic fluid is vital to proper system operation. Use only clean fluid from sealed containers and avoid contamination from dirty funnels, tubing, etc. Do not use alcohol to clean hydraulic components.

8.004 Hydraulic Pump Description

The R44 hydraulic system uses a single stage, positive displacement gear pump. The pump drive shaft is splined to a pinion gear which is driven by the main rotor gearbox ring gear. The pump gears are supported by needle bearings. The pump drive shaft is designed to shear to protect the main gearbox if pump were to seize. Dual seals prevent cross-contamination of gearbox and hydraulic fluids. A vent hole between the seals also acts as a drain to indicate if either seal has failed.

8.005 Hydraulic Reservoir Description

The reservoir assembly includes a filter, pressure relief valve, pump bypass solenoid, return shut-off valve, and ports to and from the pump and to and from the servos. Reservoir capacity is 1.3 pints. A sight glass for pre-flight fluid level checks is also provided along with a removable filler-vent to allow addition of fluid. A 1.25 inch diameter hose directs cooling air from the engine-driven fanwheel to the reservoir cooling fins.

The filter is a disposable cartridge rated at 10 microns (P/N AN6235-1A), to be replaced at intervals specified in Table 1 Scheduled Inspections (ref. § 1.101). Full-flow filtration is provided for all flow from the pump.

The pressure relief valve regulates system pressure to 450–500 psi. Since the pump provides enough flow to meet servo requirements during severe flight conditions, excess flow is available under normal flight conditions. The excess fluid flows through the pressure relief valve directly back into the reservoir.

The pump bypass solenoid allows the pilot to shut off hydraulic pressure to the servos. Switching off the hydraulics at the pilot's cyclic control grip energizes the solenoid, which opens a valve to the reservoir and depressurizes the system. Since electric power is only required to switch the system off, an electrical system failure does not affect hydraulic operation. The solenoid valve is provided primarily to allow pilot training with hydraulics off.

The return shut-off valve closes the return from the actuators whenever system pressure drops below 80 psi. The valve assures that the irreversible feature of the actuators functions properly by preventing hydraulic fluid from leaving the servos if system pressure is lost. The valve includes a thermal relief feature to prevent excessive pressure due to thermal expansion of the fluid.

8.006 Hydraulic Servo Description

The purpose of the servo is to provide output motion equivalent to pilot input motion without transmitting main rotor feedback forces to the pilot's controls. The clevis at the input end has an over-sized hole to allow pilot input to move the control valve while also providing a direct mechanical link if hydraulic pressure is lost. With hydraulic pressure, servo output immediately matches input. Absent hydraulic pressure, the servo input clevis allows 0.040 inch total travel ("freeplay") prior to causing servo output. An irreversible feature is included to reduce pilot control forces with hydraulics off. A 40-micron filter is located at the pressure port to prevent contamination during maintenance. The pressure and return ports are different sizes to prevent incorrect installation of hydraulic lines.

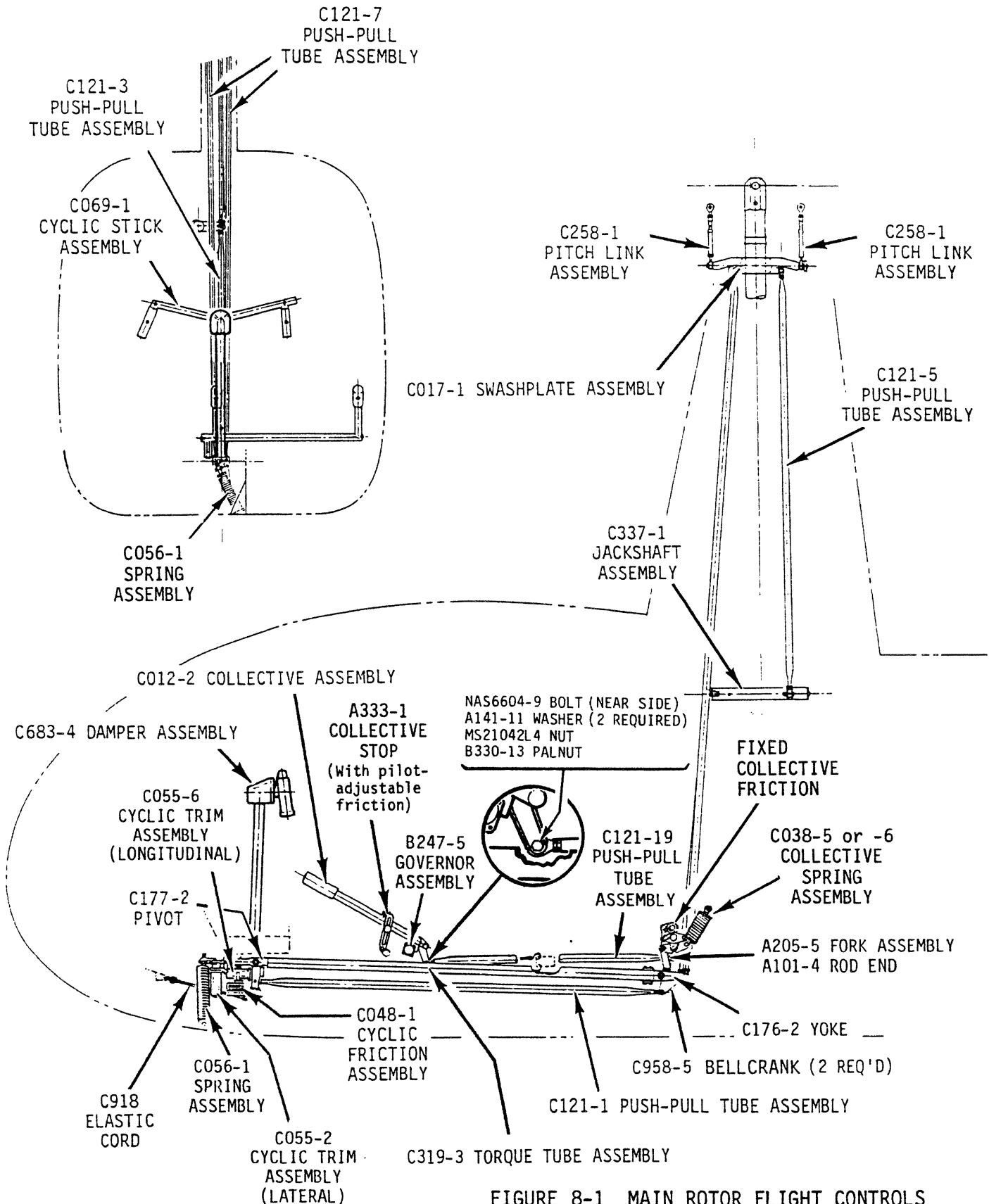

**FIGURE 8-1 MAIN ROTOR FLIGHT CONTROLS
(Electric Trim System)**

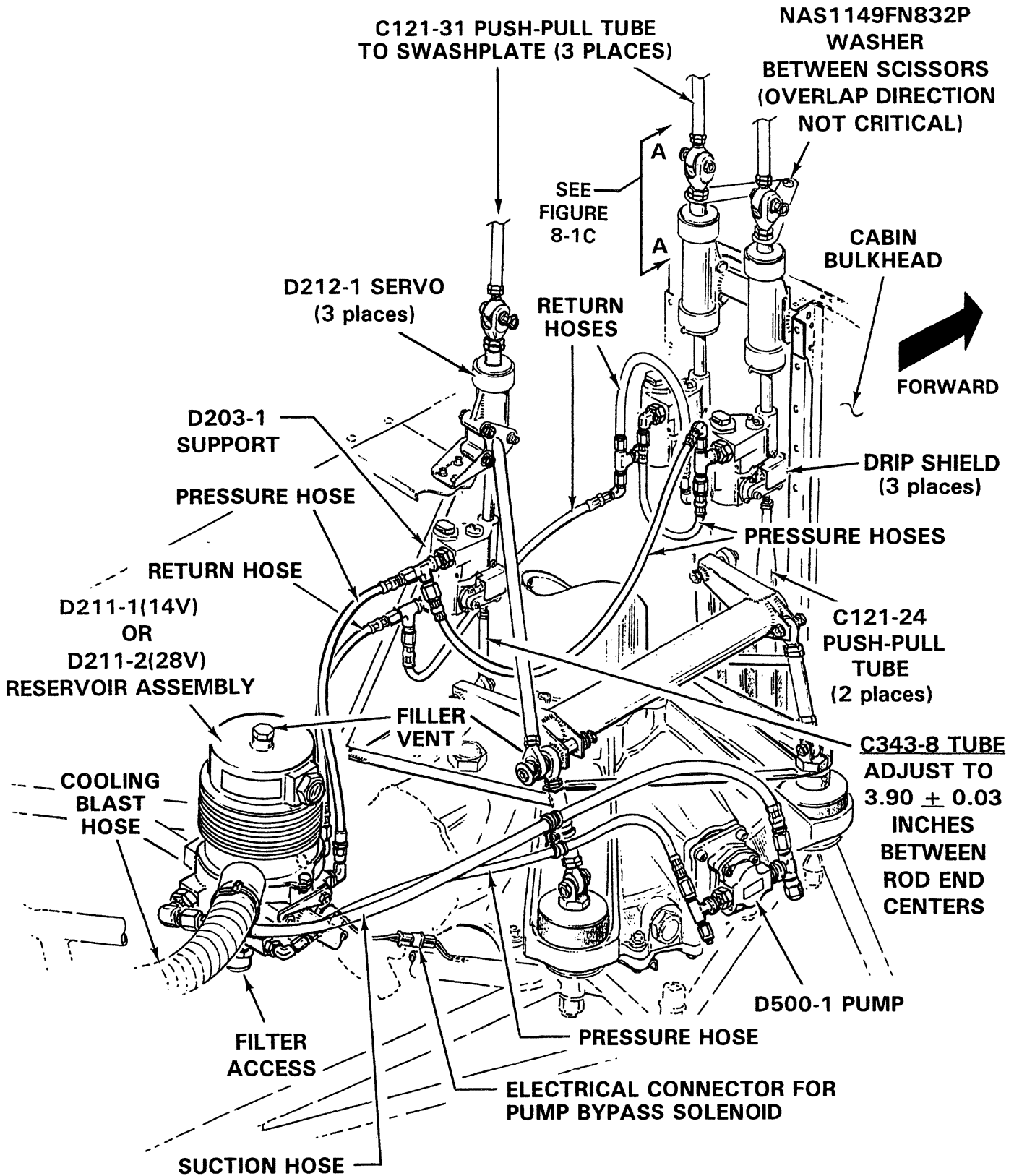

FIGURE 8-1A
HYDRAULIC FLIGHT CONTROL SYSTEM

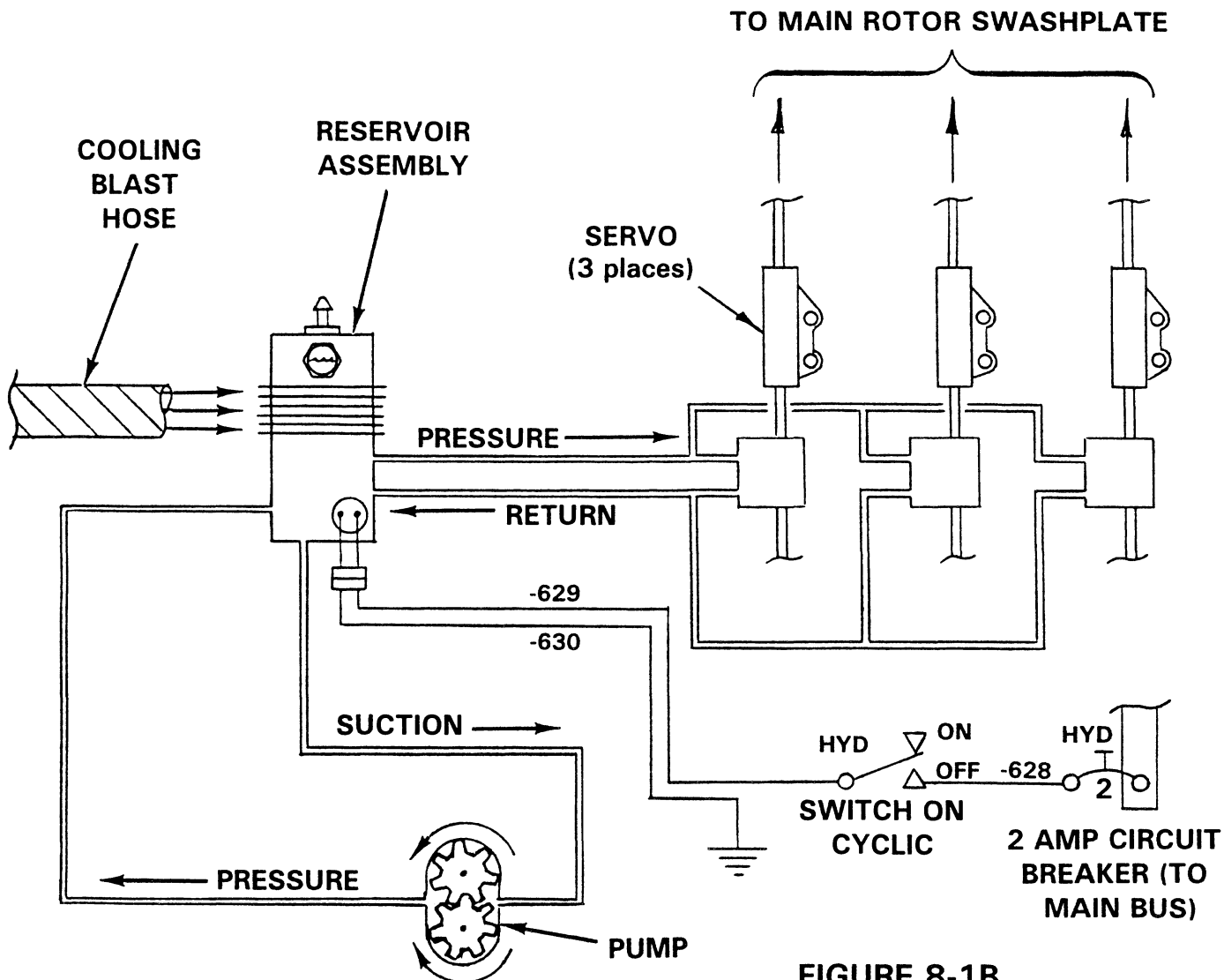

FIGURE 8-1B
HYDRAULIC SYSTEM SCHEMATIC

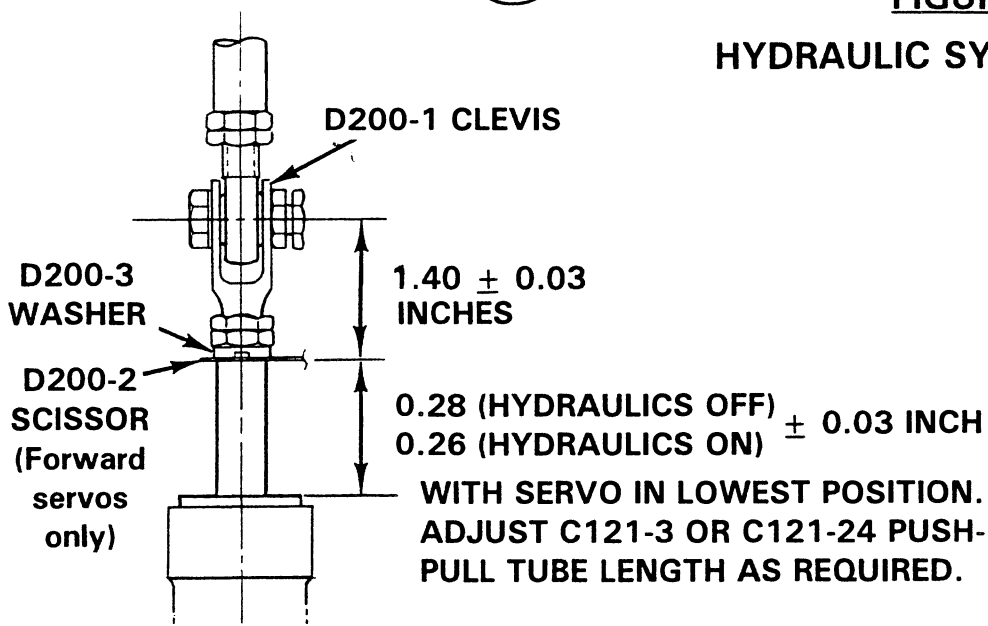

FIGURE 8-1C
SERVO RIGGING
(Typical three places)

(View A-A from Figure 8-1A)

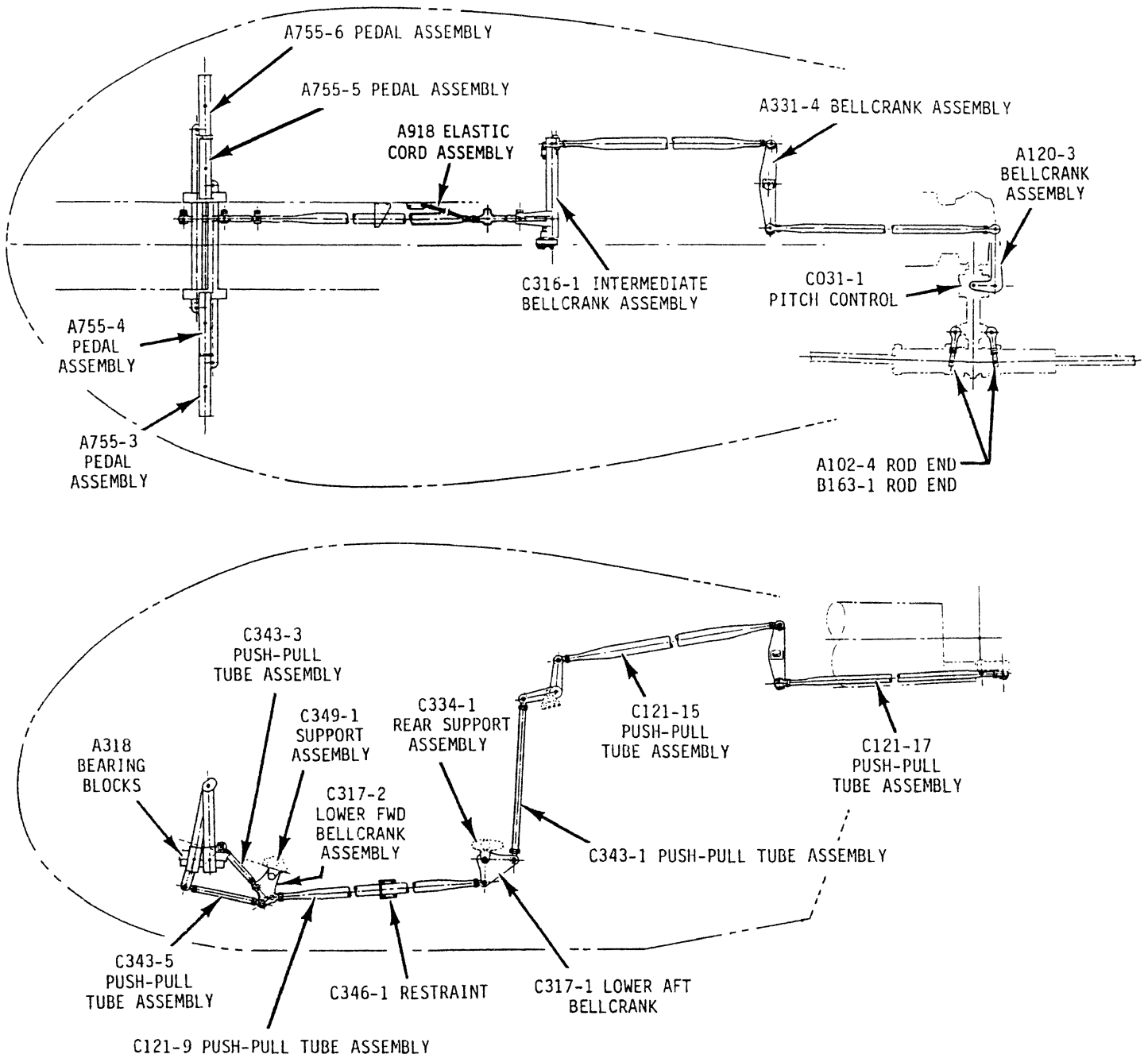

FIGURE 8-2 TAIL ROTOR FLIGHT CONTROLS

8.100 CYCLIC CONTROLS

WARNING

Manual control (electric-trim) R44s require 0.065 inch wall thickness C319-3 torque tube assemblies with C177-2 pivot (C177-4 pivot assembly) and C176-3 yoke. R44s with hydraulic flight controls require 0.049 inch wall thickness C319-5 torque tube assemblies with C177-3 pivot and D696 yoke.

8.110 Cyclic Assembly

8.111 Cyclic Assembly Removal

- a) Remove belly panels and control tunnel covers.
- b) Remove roll pin from cyclic friction knob and remove knob. Install a pin on shaft to retain spacers. Remove carburetor heat control knob on ships equipped with carb heat assist.
- c) Remove C683-4 damper atop cyclic stick (not applicable to hydraulic flight controls).
- d) Remove all screws securing C444-1 cover. Disconnect post light wire and secure cover at highest point of cyclic stick.
- e) Open upper console and disconnect outside air temperature gauge and intercom system controller wiring. Remove radio face plate.
- f) Remove forward and aft longitudinal cyclic trim elastic cords per Section 8.131.

8.111 Cyclic Assembly Removal (cont'd)

- g) Install MT544-2 lateral trim spring assembly retainer onto lateral trim spring per Section 8.141. Remove B330-13 palnut and AN316-4R nut atop lateral trim spring shaft. It is not necessary to remove motor assembly from cyclic assembly.
- h) Disconnect electrical connections at bottom of cyclic stick.
- i) Remove NAS6604-8 bolt from forward end of C121-1 push-pull tube. Move push-pull tube aft and/or move cyclic grip aft to disconnect push-pull tube from cyclic stick.
- j) Remove two bolts connecting forward end of C319-3 torque tube assembly to C177-2 pivot and move torque tube assembly aft to disconnect it from pivot.

CAUTION

Protect C319-3 torque tube from scratches.

- k) Disconnect, but do not remove, two bolts holding cyclic friction assembly to cabin. Apply friction to help keep assembly together.
- l) Remove screws securing cyclic box to cabin. Lift cyclic assembly up and disconnect strain gage plug on left side of cyclic box, slide lateral trim assembly arm off spring assembly shaft, and remove cyclic stick assembly. Install nuts onto two friction assembly bolts, hand tight, to retain bolts and spacers.

CAUTION

Before removing cyclic, protect silicone-covered strain gages on cyclic stick with soft cloth or foam. Damaged strain gages or wiring will disable electronic trim system.

- m) Remove A231-9 hole plugs in keel panel in right aft baggage compartment. Remove NAS6605-46 bolt, C130-7 spacer and hardware connecting C121-7 push-pull tube lower rod ends to C176-2 yoke.
- n) Remove NAS6605-16 bolt and hardware connecting C121-3 push-pull tube lower rod end to C958-5 bellcrank.
- o) Disconnect A205-5 fork assembly from C326-7 bellcrank by removing NAS6604-38 bolt, C130-12 spacer, and related hardware.
- p) Remove C319-3 torque tube assembly and attached parts by moving assembly down and aft through belly.

8.112 Cyclic Assembly Installation

- a) Install C319-3 torque tube assembly (with attached C121-1 push-pull tube assembly, C176-2 yoke, C958-5 bellcranks, and A205-5 fork assembly) through aft belly of helicopter. Before installation, verify center-to-center distance between B115-1 bearings and A101-4 rod end in A205-5 fork is 3.80 ± 0.03 inches and jam nut and palnut are torqued per Section 1.320.
- b) Connect A205-5 fork assembly to C326-7 bellcrank per Figure 8-3 and torque.
- c) Connect lower end of C121-3 push-pull tube to C958-5 bellcranks and torque.
- d) Connect C121-7 push-pull tubes to C176-2 yoke using a NAS6605-46 bolt and C130-7 spacer and torque. Install two A231-9 hole plugs in keel panel.
- e) Position cyclic stick between keel panels. Connect strain gage wire plug to cyclic box, carefully slide lateral trim assembly arm onto spring assembly shaft, and guide carb heat assist rod (if installed) thru box. Install all screws fastening cyclic box to cabin.

CAUTION

Exercise care when installing lateral trim assembly arm onto spring shaft to avoid damaging teflon liner in bearing bore.

- f) Connect C319-3 torque tube assembly to C177-2 pivot and torque.

CAUTION

Protect C319-3 torque tube from scratches.

- g) Fasten cyclic friction assembly to cabin.
- h) Connect forward end of C121-1 push-pull tube to cyclic stick and torque.
- i) Connect all electrical plugs at bottom of cyclic stick. Position protective sleeving to cover maximum amount of wiring possible and secure sleeving ends with lacing tape.
- j) Finger tighten AN316-4R nut on lateral trim spring shaft then install and torque B330-13 palnut. Remove MT544-2 retainer.
- k) Install longitudinal cyclic trim elastic cords per Section 8.132.
- l) Move cyclic control through all positions and verify that there are clearances and no binding. Turn master battery and trim switches on and check clearances with trim motor arms in different positions. Use circuit breakers to control position at which arms stop.

8.112 Cyclic Assembly Installation (cont'd)

- m) Install radio face plate, connect OAT gage and intercom system wires and ty-rap as required. Close and secure upper console.
- n) Connect cyclic box cover post light wire, guide carb heat assist actuating rod (if installed) thru hole in cover, and secure cover. Install cyclic friction knob, and roll pin. Install carburetor heat control knob on ships with carb heat assist.
- o) Install C683-4 damper assembly atop cyclic stick and torque per Section 1.330 (not applicable to hydraulic flight controls).
- p) Install all panels.
- q) Rig main rotor flight controls per Section 10.121 if any push-pull tube length was changed.
- r) Adjust trim controller per Section 14.710.

8.120 Cyclic Grip Assembly

8.121 Cyclic Grip Assembly Removal

This may be accomplished without removal of complete cyclic assembly from rotorcraft.

- a) If installed, remove C683-4 damper and disconnect D140-1 trim controller from airframe wiring.
- b) Remove forward belly panel.
- c) Remove lacing tape from both ends of protective sleeving covering wires exiting base of stick assembly. Using pin extractor, remove from housing those pins connected to wires 234, 235, 236, 277, 280, 281, 611, 612, 613, 614, 615, and 939 (if installed). Attach a 3 foot length of safety wire or wire lacing tape to one removed pin.
- d) Remove cotter pin, castellated nut, and A141-14 washer where grip assembly attaches to stick assembly.
- e) Remove grommet atop cyclic stick at grip assembly wiring entrance. With a soft-faced hammer, gently tap cyclic grip assembly pivot and remove grip assembly and attached wiring from stick assembly. Ensure safety wire or lacing installed in step c) protrudes from top and bottom of stick assembly. Also, ensure pivot bearings remain with stick assembly.

NOTE

Do not damage bearings while removing.

This page intentionally left blank.

C334 AFT SUPPORT ASSEMBLY

<u>NUMBER</u>	<u>PART NUMBER</u>	<u>DESCRIPTION</u>	<u>NUMBER</u>	<u>PART NUMBER</u>	<u>DESCRIPTION</u>
1.	MS21042L3	Nut	27.	AN316-4R	Nut
2.	AN960-10L	Washer	28.	A127-4	Rod End
3.	D336-1	Plate	29.	NAS6604-8	Bolt
4.	C130-24	Spacer	30.	A141-3	Washer
5.	A130-21	Spacer	31.	A105-3	Journal
6.	C130-25	Spacer	32.	C317-1	Bellcrank Assy
7.	B1000-050-S	Spring Washer	33.	C121-9	Push-Pull Tube Assy (Ref)
8.	NAS6603-11	Bolt	34.	NAS6604-7	Bolt
9.	B249-6	Arm Assembly	35.	A205-5	Fork Assembly
10.	C315-7	Aft Support Assy Weldment	36.	C130-12	Spacer
11.	NAS6604-2	Bolt	37.	AN316-6R	Nut
12.	MS21042L4	Nut	38.	D173-1	Rod End
13.	AN960-416	Washer	39.	C121-19	Push-Pull Tube Assy (Ref)
14.	AN960-416L	Washer	40.	A130-47	Spacer
15.	B330-19	Palnut	41.	NAS6604-38	Bolt
16.	MS21042L6	Nut	42.	C326-7	Bellcrank
17.	AN960-616	Washer	43.	B303-1	Bearing
18.	B250-11	Journal	44.	C130-32	Spacer
19.	NAS6606-17	Bolt	45.	C958-5	Bellcrank
20.	B330-13	Palnut	46.	AN316-5R	Nut
21.	C038-5 or -6	Collective Spring Assy (Ref)	47.	B330-16	Palnut
22.	C311-1	Bolt	48.	A101-4	Rod End
23.	A141-11	Washer			
24.	NAS6604-11	Bolt			
25.	C343-1	Push-Pull Tube Assy (Ref)			
26.	B316-4	Rod End			

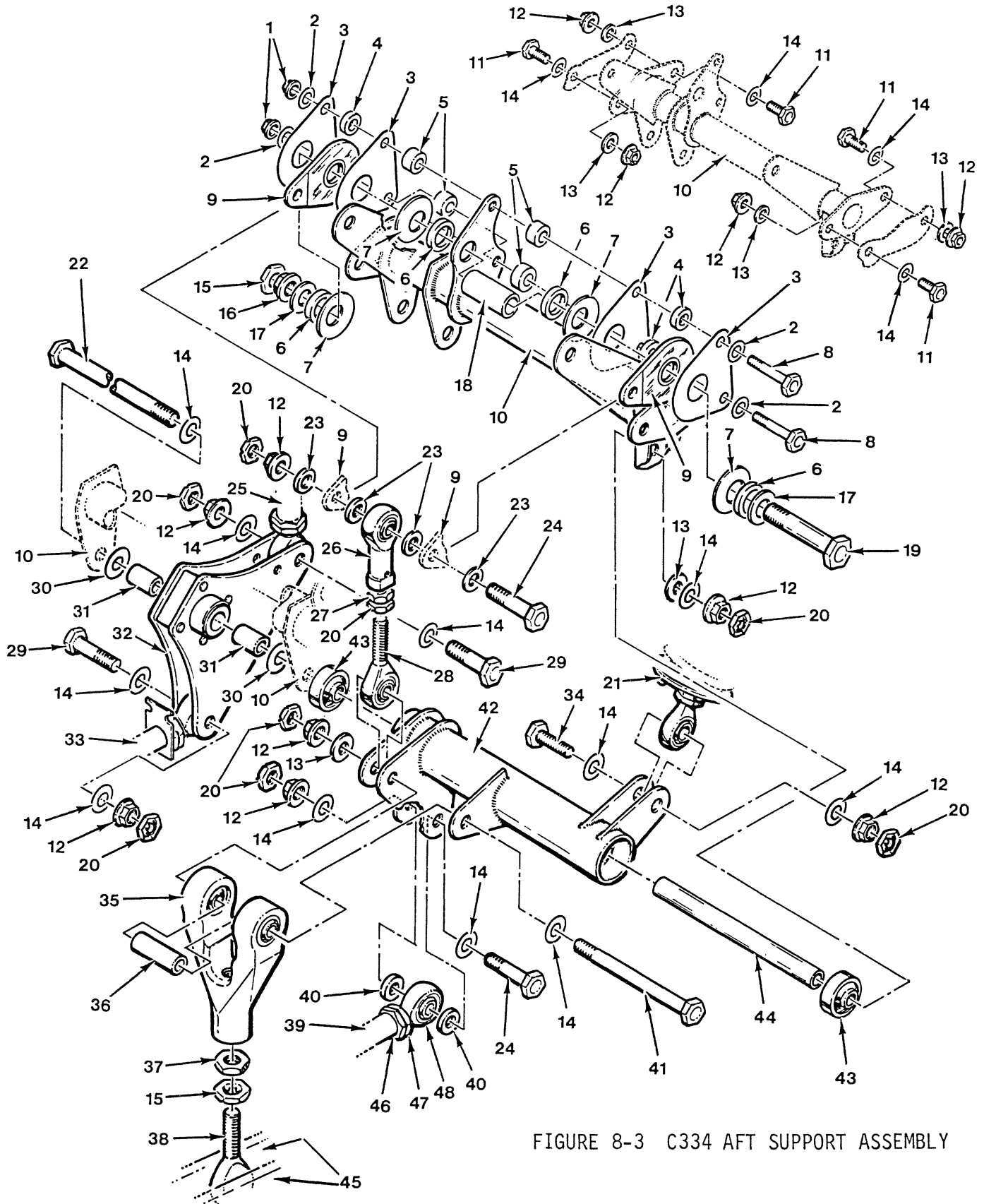

FIGURE 8-3 C334 AFT SUPPORT ASSEMBLY

8.122 Cyclic Grip Assembly Installation

- a) Ensure rollpin is installed in grip assembly with protruding end down. Protective sleeving covers wires exiting grip assembly with one grommet in grip and one on wire bundle.
- b) Slide grip assembly into bearings in stick assembly. Install A141-14 washer, castellated nut and cotter pin.

CAUTION

Tighten castellated nut only until there is no axial movement of bearings and cyclic grip assembly. Overtightening nut will damage bearings.

- c) Temporarily attach grip assembly wiring to safety wire (or lacing) exiting atop cyclic stick. Carefully pull wires thru cyclic stick. Install grommet, included with grip assembly wiring, into cyclic stick wiring entrance hole. Route grip assembly wires thru existing sleeving protecting wires exiting cyclic stick bottom. Remove safety wire (or lacing).
- d) Install pins on each wire into proper position in housings. Refer to Figures 14-2 and 14-4 for pin position.
- e) Position protective sleeving on wiring exiting cyclic stick bottom to cover maximum amount of wiring possible. Secure sleeving ends with lacing tape.
- f) Connect cyclic and airframe wiring and ty-rap. Move cyclic control through all positions and verify clearance and no binding. Turn master battery and trim switches on and check clearances with trim motor arms in different positions. Use circuit breakers to stop arms in different positions.
- g) Install end cap (hydraulic flight control) or C683-4 damper assembly (manual flight control) atop cyclic stick. Torque damper assembly attaching screws per Section 6.330.
- h) Install forward belly panel.
- i) Adjust trim controller per Section 14.710 (not applicable to hydraulic flight controls).

8.130 Longitudinal Cyclic Trim Elastic Cords

Elastic cords are used to zero longitudinal cyclic stick forces during hovering and cruise flight. Refer to Figures 8-4 and 8-4A.

One or two cyclic trim elastic cords are installed in the R44. One aft (cruise) cord, which imparts a forward cyclic force, is connected to the longitudinal trim motor cable. One optional forward (hover) elastic cord, which imparts an aft cyclic force, may be connected to the bottom of the cyclic stick assembly. Before replacing any elastic cord, ensure longitudinal trim motor arm is traveling thru its full operating range when cyclic stick is placed in full forward and then full aft position.

If cyclic grip moves forward in hover, a stronger forward elastic cord is required. If cyclic grip moves aft in cruise flight, a stronger aft elastic cord is required. Decreasing forward (hover) elastic cord strength by 5 pounds has the same effect as increasing aft (cruise) elastic cord strength by 10 pounds.

- a) Remove elastic cord per Section 8.131 and determine part number from identification tag.

NOTE

The R44 IPC lists elastic trim cords by part number and installed load (force).

- b) Using above information, and amount of force required to counter cyclic force, select an appropriate elastic trim cord from the IPC. If cord is old, try replacing it with same part number new cord first.
- c) Install per Section 8.132.
- d) Test fly helicopter to determine if proper cord was selected. The cyclic trim must zero (neutralize) cyclic forces during a 100 KIAS autorotation at C.G. station 99+.
- e) Repeat steps a) thru d) as required to balance longitudinal cyclic forces.

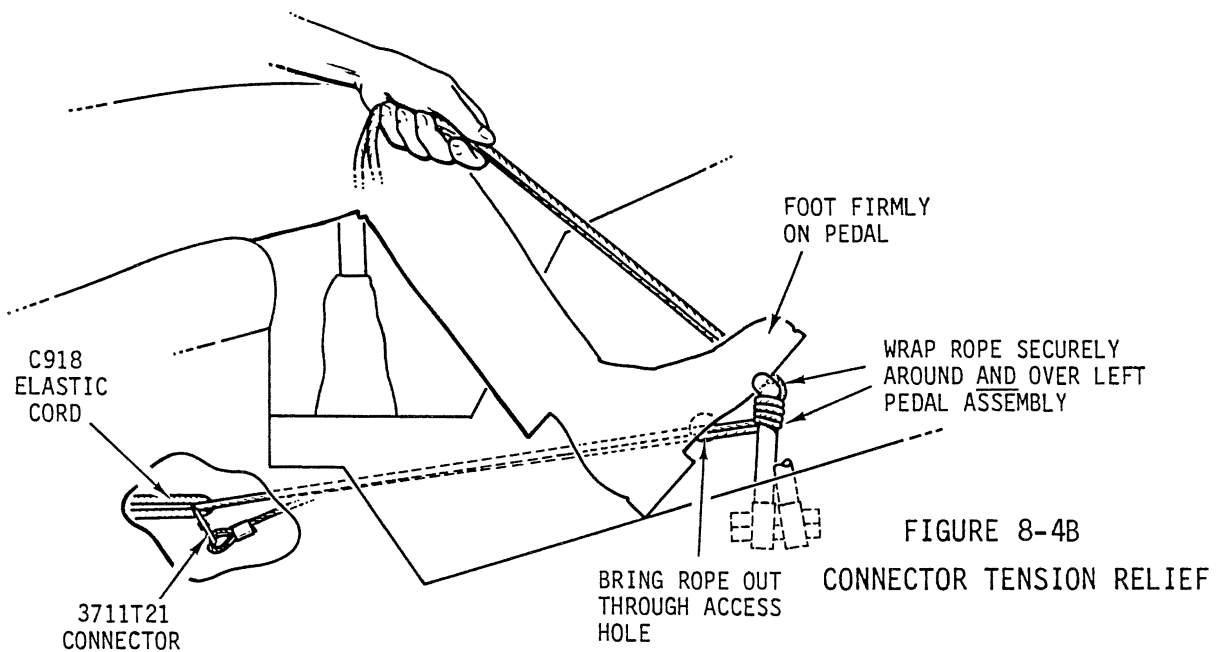
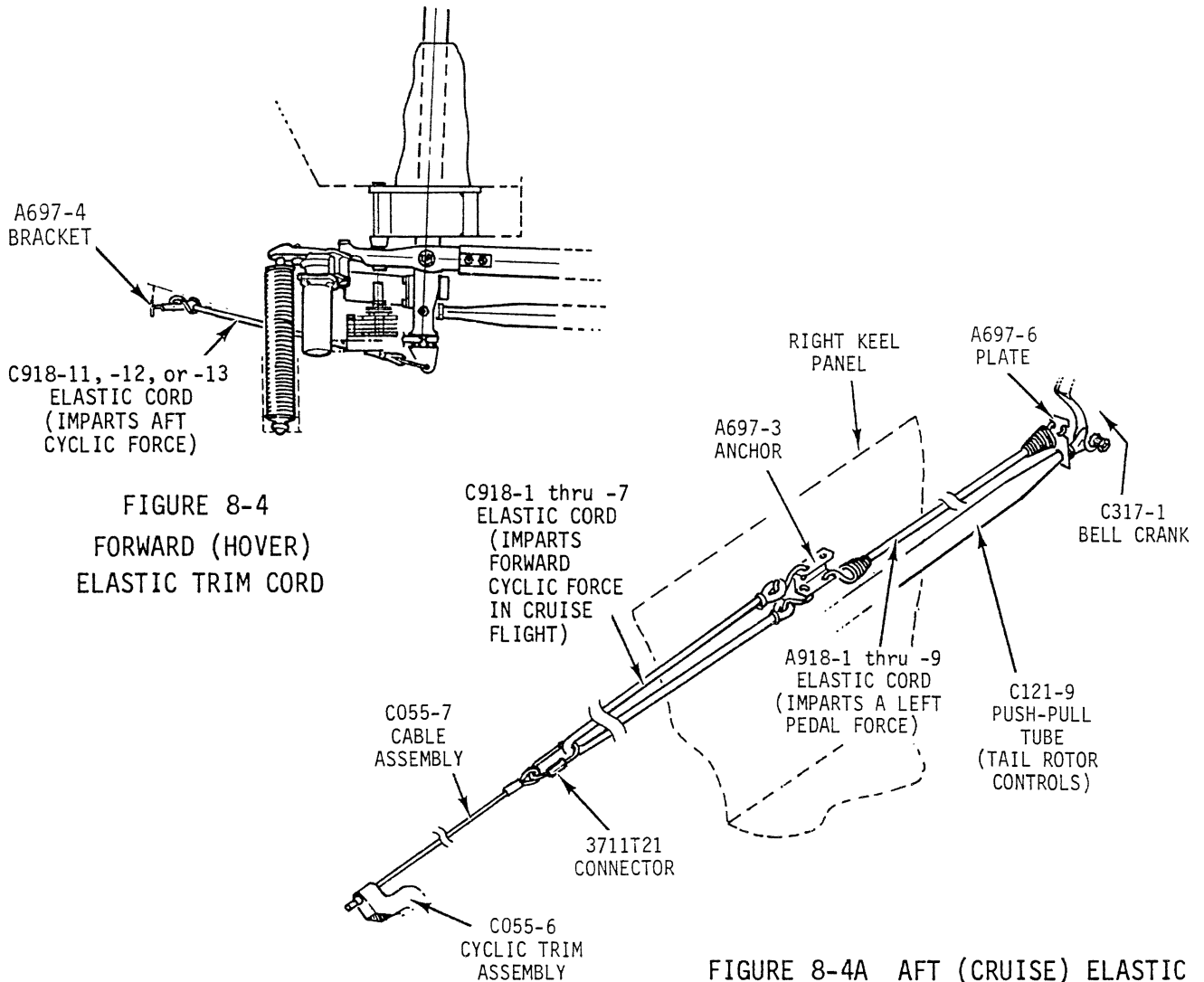

8.131 Elastic Cord Removal

NOTE

See Section 2 for elastic cord inspection criteria.

1. Aft elastic cord (C918-1 through -9):
 - a) Remove control tunnel covers (reference Figure 2-2, item 3A & 4F).
 - b) Turn master battery and trim switches on. Hold cyclic stick firmly against aft stop to allow longitudinal trim motor arm to go to upper stop. Turn master battery and trim switches off.
 - c) Move cyclic stick full forward. Remove black plastic hole plug from right keel panel just aft of right side tail rotor pedals.
 - d) Refer to Figure 8-4B. Apply full right pedal. Route one end of an 8 foot length of 1/4 inch diameter nylon rope through right keel panel hole just aft of right side tail rotor pedals, through C918 elastic cord next to 3711T21 connector and back through keel panel hole. Wrap both ends of rope around left pedal and hold securely. Slowly apply left pedal to take up slack on rope and relieve tension on 3711T21 connector. Unhook connector from C918 elastic cord. Let left pedal return slowly full aft.

CAUTION

Always remove tension on 3711T21 connector before unscrewing it. **DO NOT** allow C918 elastic cord to put tension on an unsecured 3711T21 connector.

- e) Very slowly, ease off tension on rope until there is no more tension on elastic cord.
 - f) Unhook both ends of elastic cord from A697-3 anchor riveted to right keel panel. Remove elastic cord.
2. Forward elastic cord (C918-11, -12, -13):
 - a) Remove forward belly panel.
 - b) Move the cyclic to full aft position.
 - c) Unhook the forward trim cord from the A697-5 clip located at the bottom of the cyclic stick.
 - d) Remove the trim cord hook from the forward bracket.

8.132 Elastic Cord Installation

1. Aft elastic cord installation

CAUTION

C918-8 and -9 elastic cords may only be used with C055-10 cyclic trim assembly.

- a) Hook both ends of trim cord to A697-3 anchor on right keel panel.
- b) Move cyclic to full forward position with longitudinal trim motor arm in up position.
- c) Refer to Figure 8-4B. Apply full right pedal. Route one end of an 8 foot length of 1/4 inch diameter nylon rope through right keel panel hole just aft of right seat tail rotor pedals, through C918 elastic cord next to 3711T21 connector, and back through keel panel hole. Wrap both ends of rope around left pedal and hold them securely.
- d) Reference Figure 8-4A. Slowly apply left pedal to stretch C918 elastic cord. Install and secure the 3711T21 connector between the C918 elastic cord and C055-7 cable assembly. Reference Figure 8-4A. Slowly release tension on rope. Remove rope.

CAUTION

DO NOT allow the C918 elastic cord to apply tension to an unsecured 3711T21 connector.

WARNING

Turn on trim system and ensure clearance is maintained between the elastic cord hooks, push-pull tubes and wiring throughout entire cyclic control and trim system travel.

- e) Reinstall all panels and the hole plug.
- f) Evaluate trim cord per Section 8.130(d).

8.132 Elastic Cord Installation (cont'd)**2. Forward elastic cord installation**

- a) Hook forward end of elastic cord to bracket under radio rack.
- b) Pull cyclic to full aft position and hook aft end of trim cord to A697-5 clip located at bottom of cyclic stick.

WARNING

Turn on trim system and ensure clearance is maintained between elastic cord hooks, push-pull tubes, and wiring throughout entire cyclic control and trim system travel.

- c) Install belly panel.

8.140 Lateral & Longitudinal Cyclic Trim Assemblies**8.141 Lateral Cyclic Trim Assembly Removal (C055-2 or C055-9)**

- a) Remove forward belly panel and panel between forward seats.
- b) Remove roll pin from cyclic friction knob and remove knob. Install pin on shaft to retain spacers. Remove carburetor heat control knob on ships equipped with carburetor heat assist.
- c) Remove all screws securing C444-1 cover. Disconnect post light wire and secure cover at highest point of cyclic stick.
- d) Open upper console and disconnect the OAT gage and intercom system wiring. Remove radio face plate.
- e) Turn master battery and trim switches on. Move and hold cyclic against right stop until lateral trim arm moves fully left. Then turn trim and master battery switches off and move cyclic stick to full left position to compress trim spring.
- f) Install MT544-2 lateral spring assembly retainer and secure with heavy-duty ty-raps at two places to spring assembly. Remove palnut and AN316-4R nut atop spring shaft.
- g) Disconnect lateral trim motor wiring.
- h) Remove two NAS6603-26 bolts which connect trim assembly to C177-2 pivot.
- i) Remove gearmotor assembly.
- j) If necessary, remove spring assembly by disconnecting C591-2 block from cabin assembly.

8.142 Lateral Cyclic Trim Assembly Installation (C055-2 or C055-9)

CAUTION

There are two trim controller part numbers: D140-1 and D140-2. D140-1 trim controller must be used ONLY with C055-2, -6 and -8 cyclic trim assemblies. D140-2 trim controller must be used ONLY with C055-9, -10 and -11 cyclic trim assemblies. Incompatible controller and trim assembly(s) will result in trim system failure.

- a) If C056-1 spring assembly was removed, install C591-2 block (permanently attached to spring assembly bottom) in cabin. Orient attaching screw heads forward. Install trim assembly's two NAS6603-26 bolts downward thru C177-2 pivot. Carefully slide trim assembly arm onto spring shaft. Position trim assembly below, and attach it to, C177-2 pivot with NAS6603-26 bolts, two AN960-10L washers and two MS21042L08 nuts. Torque bolts per Section 1.320.
- b) Install AN316-4R nut finger tight on spring shaft, then install B330-13 palnut and torque palnut per Section 1.320. Move cyclic to left and remove MT544-2 lateral spring assembly retainer.
- c) Route trim motor wiring around front of and outboard of cyclic friction assembly. Connect trim motor wiring. Ty-rap wiring as required to prevent interference with flight controls.
- d) Turn master battery and trim switches on.
- e) Move cyclic to left stop and right stop and observe movement of trim motor arm throughout full range of travel. It must be free with no binding or interference. Turn master battery and trim switches off.
- f) Install radio face plate, connect OAT and intercom system wires, and ty-rap as required. Close and secure upper console.
- g) Connect cyclic box cover post light wire, guide carb heat assist actuating rod (if installed) thru hole in cover, and secure cover. Install cyclic friction knob and roll pin. Install carburetor heat control knob on ships with carb heat assist.
- h) Install all panels.
- i) Adjust trim controller per Section 14.710.

8.143 Longitudinal Cyclic Trim Assembly Removal (C055-6 or C055-10)

- a) Remove cyclic stick assembly per Section 8.111, steps a) thru k). Alternatively, perform steps a) thru e) and g) of Section 8.111 and leave cyclic stick assembly installed.
- b) Remove two NAS1352-08 screws connecting longitudinal cyclic trim assembly to cyclic stick. Remove trim assembly.

8.144 Longitudinal Cyclic Trim Assembly Installation (C055-6 or C055-10)

CAUTION

There are two trim controller part numbers: D140-1 and D140-2. D140-1 trim controller must be used ONLY with C055-2, -6 and -8 cyclic trim assemblies. D140-2 trim controller must be used ONLY with C055-9, -10 and -11 cyclic trim assemblies. Incompatible controller and trim assembly(s) will result in trim system failure.

- a) Refer to Figure 8-4C. Install trim motor assembly on cyclic stick with NAS1352-08-12P screw NAS620-8L washer and MS21042L08 nut in lower position and lightly tighten. Pivot motor upward and install NAS1352-08-32P screw, C130-11 spacer (may be secured to motor with ty-rap to ease installation), C130-20 spacer (chamfer pointing aft), NAS620-8L washer, and MS21042L08 nut in upper position. Remove ty-rap used to position C130-11 spacer, if installed. Torque nuts to 20-25 in.-lbs (includes nut self-locking torque).
- b) If removed, install cyclic stick assembly per Section 8.112 steps e) thru q). If cyclic was not removed, connect trim motor wiring and perform steps k) thru q) of Section 8.112.
- c) Adjust trim controller per Section 14.710.

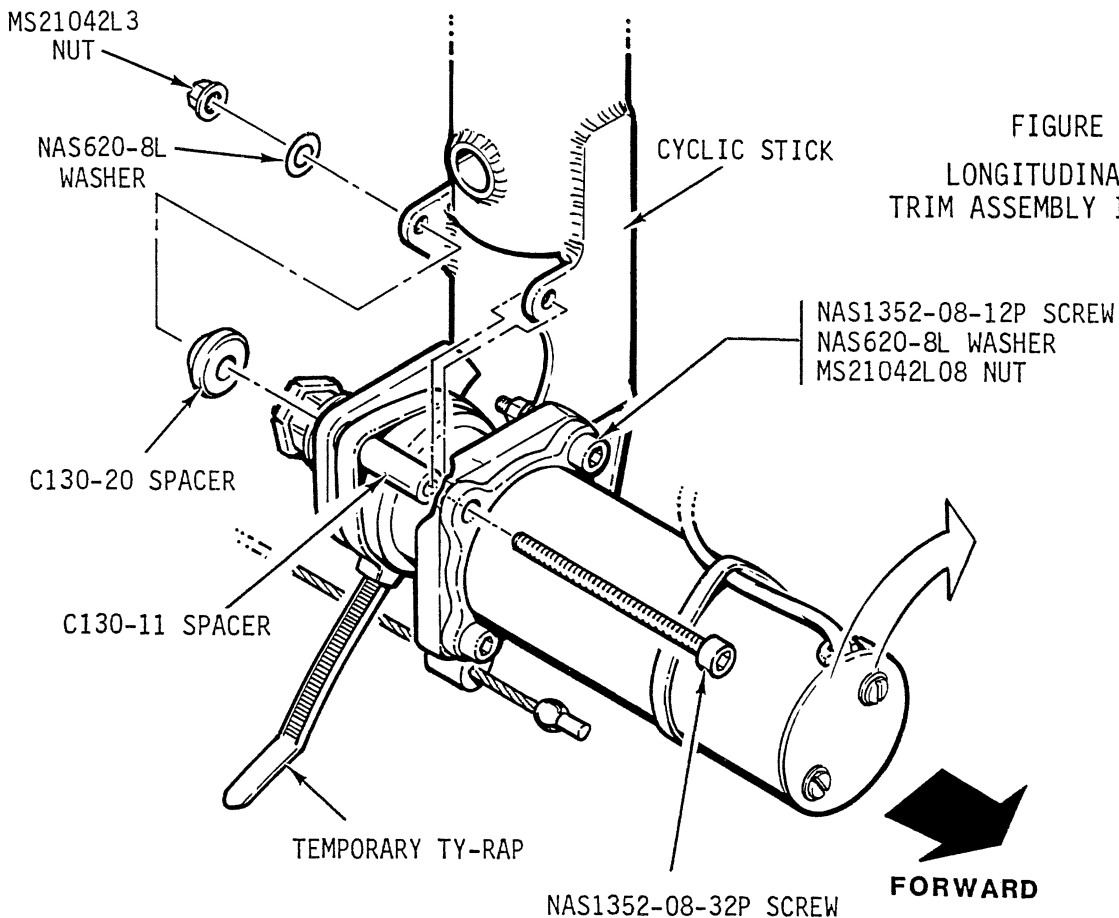

FIGURE 8-4C
LONGITUDINAL CYCLIC
TRIM ASSEMBLY INSTALLATION

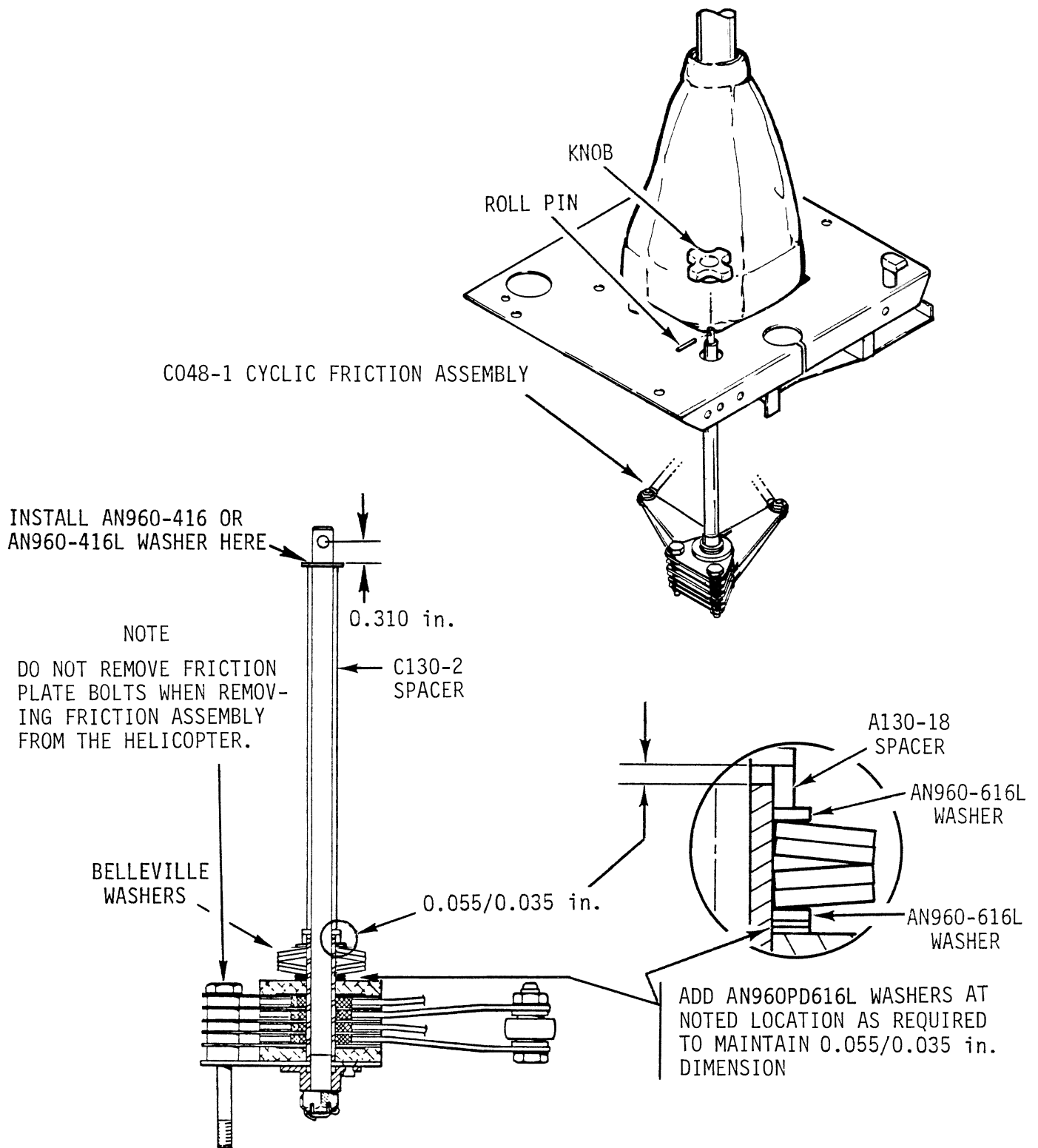

FIGURE 8-4D CYCLIC FRICTION ASSEMBLY AND ADJUSTMENT

8.150 Cyclic Friction Assembly

The cyclic friction assembly is located below the forward left corner of the cyclic box. Turning friction knob clockwise applies friction to both longitudinal and lateral cyclic axes. Adjustment is required if friction cannot be applied.

8.151 Cyclic Friction Adjustment

- a) Turn friction knob counter-clockwise until it stops.
- b) Remove roll pin connecting knob to shaft.
- c) Lift knob off shaft.
- d) Install AN960-416 or -416L washer, as required, per Figure 8-4D so knob rotates 1/8 to 1 turn before adding friction. With friction on, force required to move cyclic in a lateral direction should be 7-13 lb (measured at grip) with trim motors in neutral position.
- e) Replace knob and install roll pin.
- f) Move flight controls throughout complete travel. Verify no binding or clearance problems exist.

8.160 C121-7 Push-Pull Tube

8.161 C121-7 Push-Pull Tube Removal

- a) Remove aft belly panel.
- b) Remove mast fairing.
- c) Remove two plugs located in aft right baggage compartment.
- d) Remove NAS6605-46 bolt attaching C121-7 push-pull tube rod ends to C176-2 yoke.
- e) Disconnect bolts fastening C121-7 push-pull tubes to swashplate.
- f) Tape sheet metal edges to prevent push-pull tube damage.
- g) Position swashplate and rotor to slide C121-7 push-pull tube up and clear. Mark right and left tubes for reinstallation.
- h) Inspect push-pull tubes and sleeves for damage per Section 8.162.
- i) Inspect push-pull tube guide rollers for wear. Replace guide rollers if worn.

NOTE

If push-pull tube is replaced, adjust rod ends to obtain same center-to-center length or main rotor flight controls will require rigging per Section 10.

8.162 C121-7 Push-Pull Tube Inspection/Repair

- a) Nicks, cuts or scratches in tube which are longitudinal and no more than 0.010 inch deep, or across tube and no more than 0.005 inch deep, may be polished out.
- b) Tubes dented or flattened more than five percent of diameter must be replaced.
- c) Maximum tube wear at guide is 0.015 inch per wall after polishing wear ridges. Epoxy prime repair surfaces before sleeve installation. Any tube wear requires new sleeve installation.
- d) Replace tube worn in excess of 0.015 inch after polishing.

8.163 C121-7 Push-Pull Tube Sleeve Installation

NOTE

Repair any wear damage on C121-7 push-pull tube per Section 8.162 prior to the push-pull tube sleeve installation.

- a) Clean push-pull tube with MEK or acetone.
- b) Apply tape to restrict adhesive to a six-inch long area beginning 30.5 inches from lower end of push-pull tube (not end of rod end).
- c) Test paint for paint bubbling; apply 1-inch band of B270-3 adhesive to one end of six inch area. If paint bubbles, remove paint and apply epoxy primer to area before applying adhesive.

WARNING

Adhesive to be applied to complete area under push-pull tube sleeve.

- d) Apply adhesive supplied in kit to entire six-inch long area. (Adhesive will quickly set and become stringy. Brush on thin coat of adhesive without large lumps as rapidly as possible).

NOTE

Sleeve must be installed within two minutes after adhesive is applied.

- e) Slide sleeves onto tube and center on adhesive.
- f) Rotate tube and apply heat using up to 1200-watt heat gun to evenly shrink sleeve and produce a smooth surface.

CAUTION

DO NOT apply heat continuously to same area.

8.163 C121-7 Push-Pull Tube Sleeve Installation (cont'd)

- g) Allow to cool and apply adhesive to seal end of sleeve. Do not allow adhesive at sleeve ends above surface of sleeve or sleeve will be damaged or will not enter guide during installation.

8.164 C121-7 Push-Pull Tube Sleeve Inspection

Visually inspect sleeve for wrinkles, pin holes, bubbles, gouges, torn areas, etc. Replace sleeve if any damaged or suspect areas are found.

8.165 C121-7 Push-Pull Tube Installation**CAUTION**

Exercise extreme care when installing C121-7 push-pull tube into guide to prevent damage to push-pull tube sleeve.

- a) Install C121-7 push-pull tube and hardware per Figure 8.4F.
- b) Attach C121-7 push-pull tubes to swashplate.
- c) Reinstall mast fairing. See Figure 8-4E.

NOTE

Locate and tighten clamp holding lower fairing rib to mast tube assembly prior to closing.

- d) Remove protective tape from sheet metal edges used to protect push-pull tubes during installation and close mast fairing.
- e) Check full travel clearances of flight controls.
- f) Verify fasteners are torqued.
- g) Install panels and baggage compartment plugs.
- h) If push-pull tube rod end center-to-center dimension was changed, check main rotor rigging per Section 10.

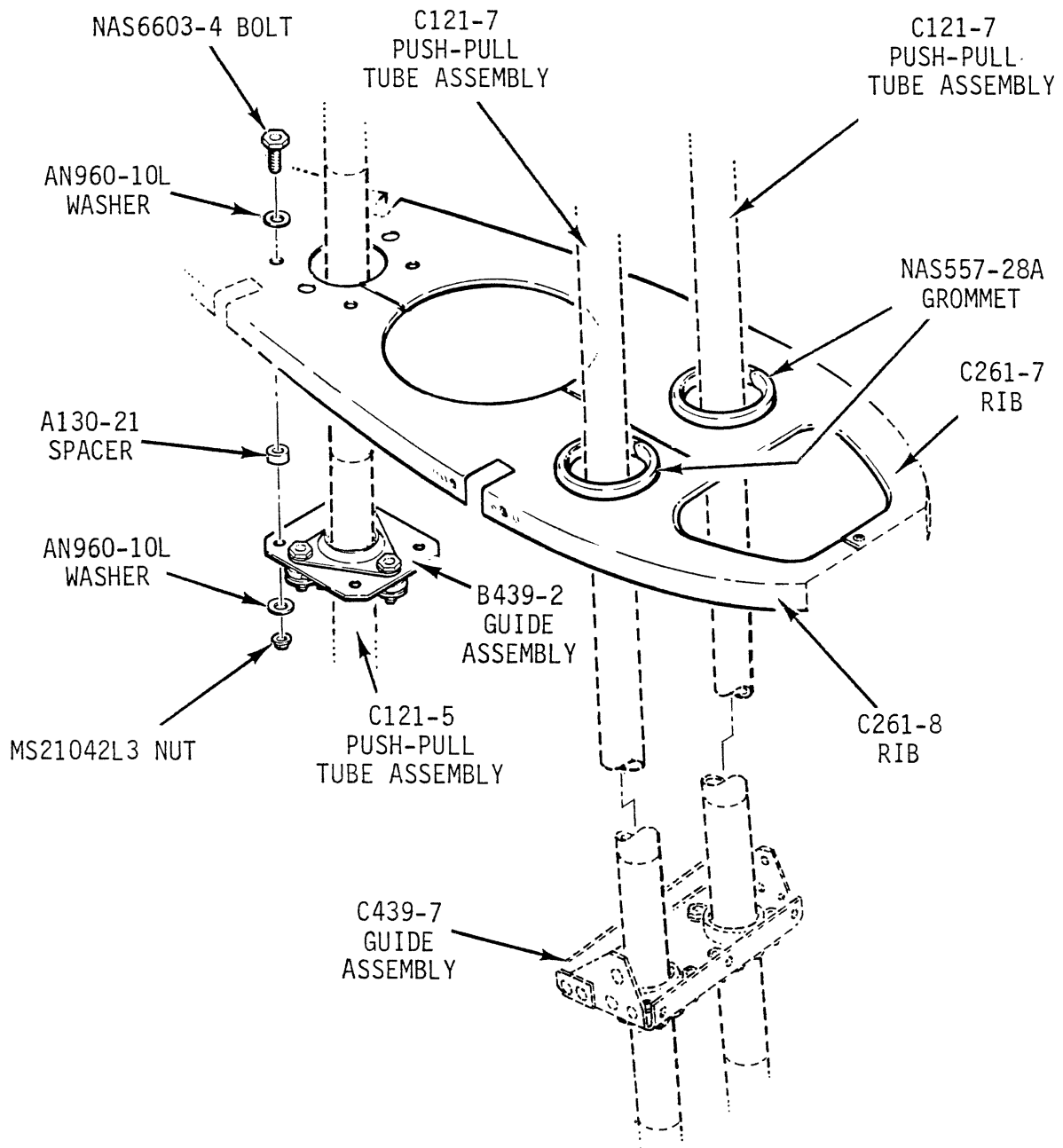

FIGURE 8-4E PUSH-PULL TUBES AND GUIDES
(Electric Trim System only)

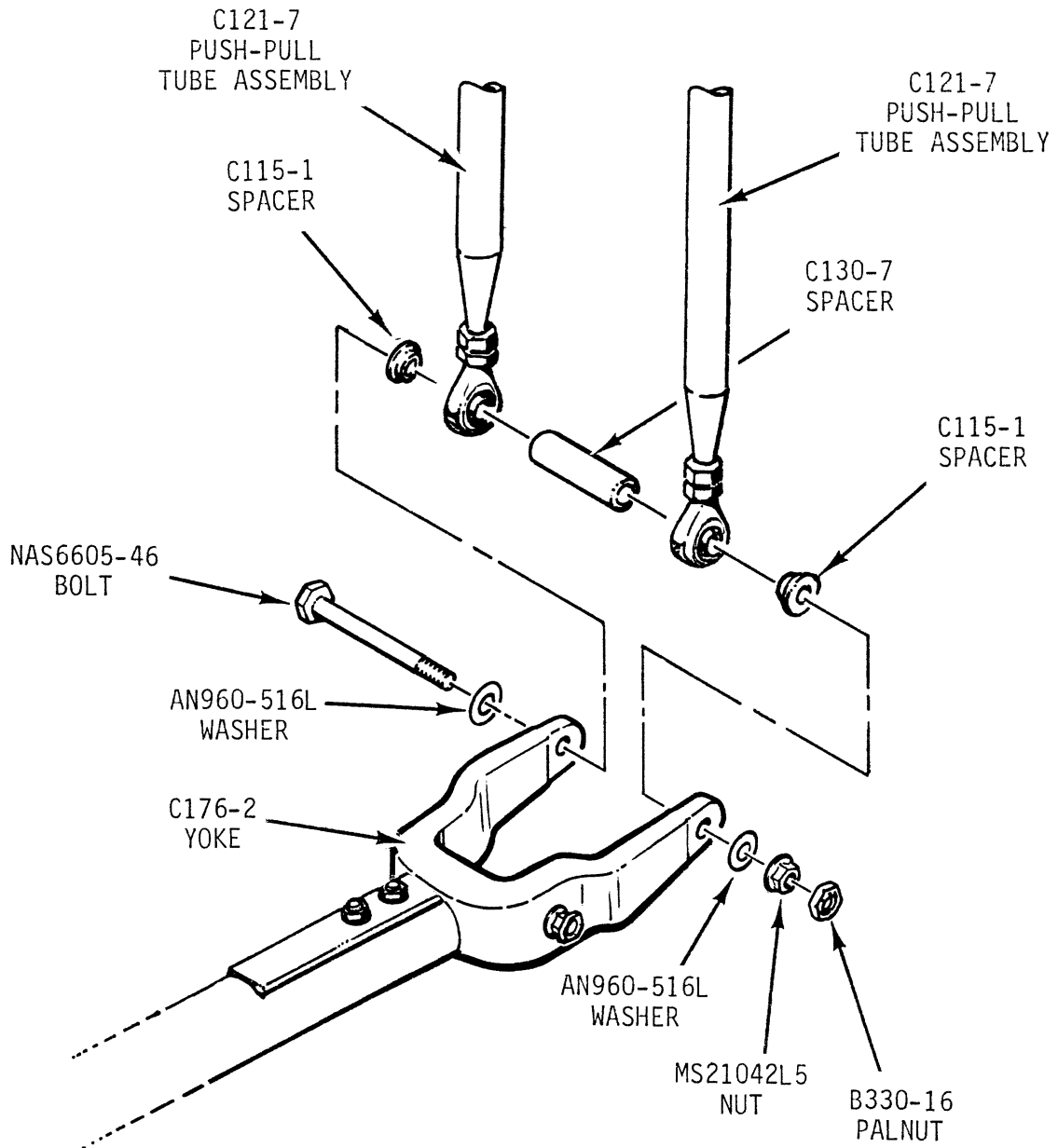

FIGURE 8-4E C121-7 PUSH-PULL TUBE ASSEMBLY INSTALLATION

8.200 COLLECTIVE CONTROL**8.210 Collective Stick Assembly****8.211 Collective Stick Removal**

- a) Remove forward horizontal panel, aft vertical panel, both collective boot covers, and the collective cover located behind forward left seat back.
- b) Install the MT544-1 spring retainer on the collective spring located at the vertical tunnel while collective is in full down position.
- c) Disconnect forward end of C121-19 Push-Pull tube from the collective by removing NAS6604-9 bolt.
- d) Unplug the governor motor wiring located near left side of collective stick.
- e) Disconnect collective stop from the anchor by removing the NAS6603-5 bolt and disconnecting the overtravel spring from the collective.
- f) Remove one NAS6604-17 bolt which connects the collective assembly to the fuselage located behind the pilot's seat on the right keel panel.
- g) Remove the three screws holding the C303-1 support at the left end of the collective. The support is to be removed with the collective assembly.
- h) Remove collective.

8.212 Collective Stick Installation

- a) Assemble A332-1 friction lever per Figure 8-5. The spring washers, item 14, should be assembled with their concave sides together. The two washers, item 13, are installed with the grey Teflon[®] coated surface against the A333-1 stop (item 12). The A332-1 lever is threaded onto the NAS1352-4-24P screw as the screw starts to protrude from the attachment fitting.

NOTE

See collective friction adjustment for finalizing friction assembly after completion of collective installation. Refer to Section 8.224.

- b) Connect C303-1 support to collective stick, if required. Install NAS6604-11 bolt and attaching hardware. Torque per Section 1.320.
- c) Install collective stick into rotorcraft.
- d) Connect collective inboard attach bolts. Torque to per Section 1.320.

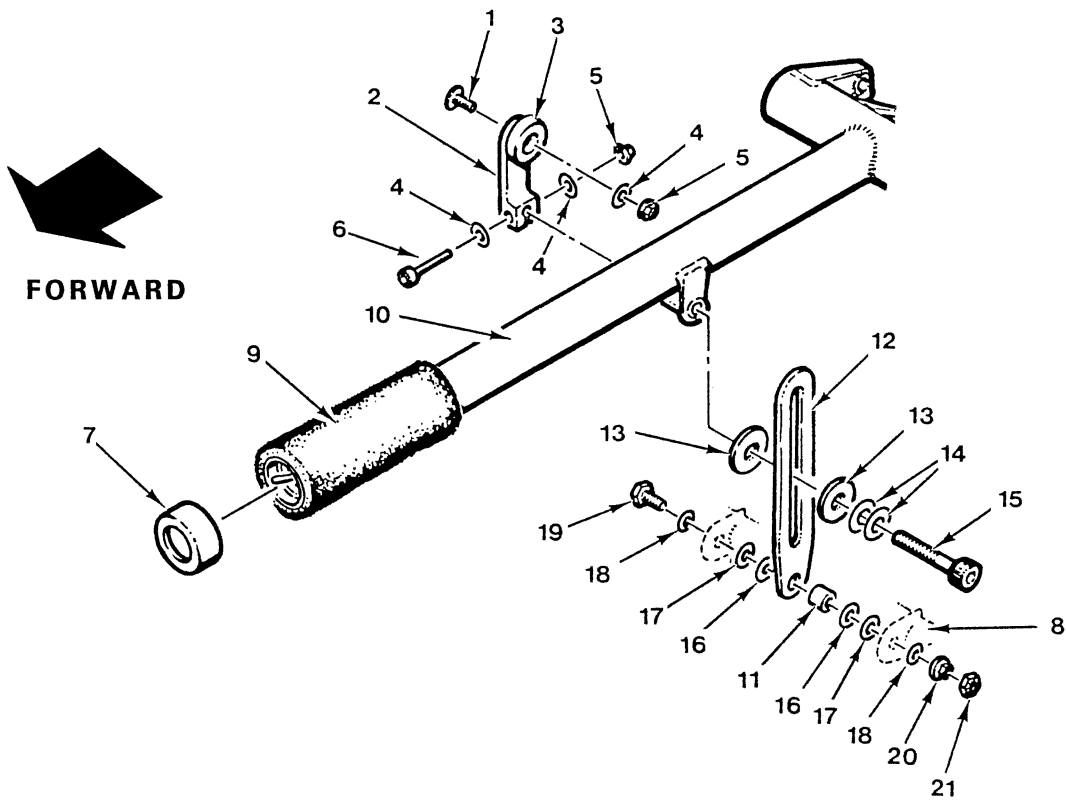

FIGURE 8-5 COLLECTIVE FRICTION ASSEMBLY

<u>NUMBER</u>	<u>PART NUMBER</u>	<u>DESCRIPTION</u>	<u>NUMBER</u>	<u>PART NUMBER</u>	<u>DESCRIPTION</u>
1	MS27039C0806	Screw	13	A141-20	Washer
2	A332-1	Lever	14	B0500-022-S	Belleville Washer
3	A431-1	Knob	15	NAS1352-4-24P	Screw
4	AN960-8L	Washer	16	AN960-416	Washer (A/R)
5	MS21042L08	Nut	17	AN960-416L	Washer (A/R)
6	NAS1352-08-12P	Screw	18	AN960-10L	Washer
7	A959-2	End Cap	19	NAS6603-5	Bolt
8	C348-1	Anchor	20	MS21042L3	Nut
9	A601-1	Grip	21	B330-7	Palnut
10	C758	Collective Assy			
11	A130-4	Spacer			
12	A333-1	Stop			

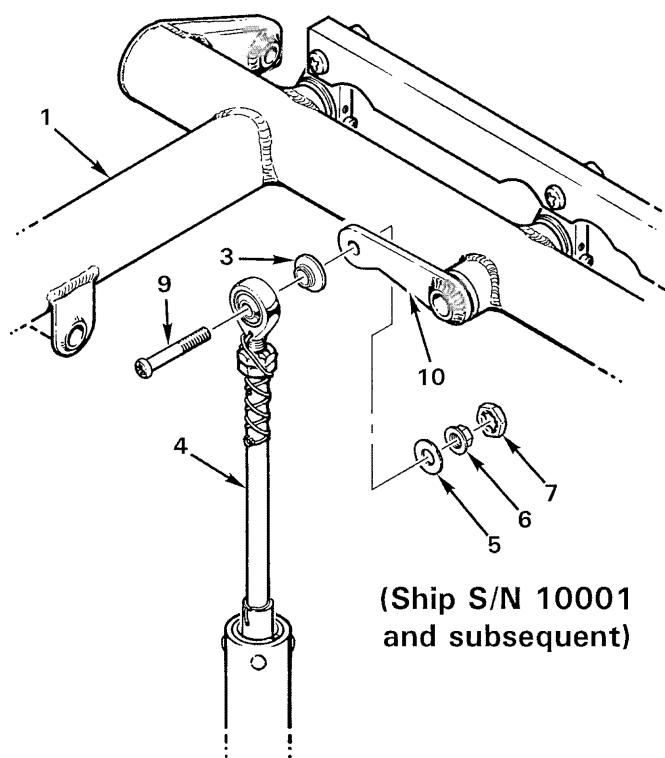
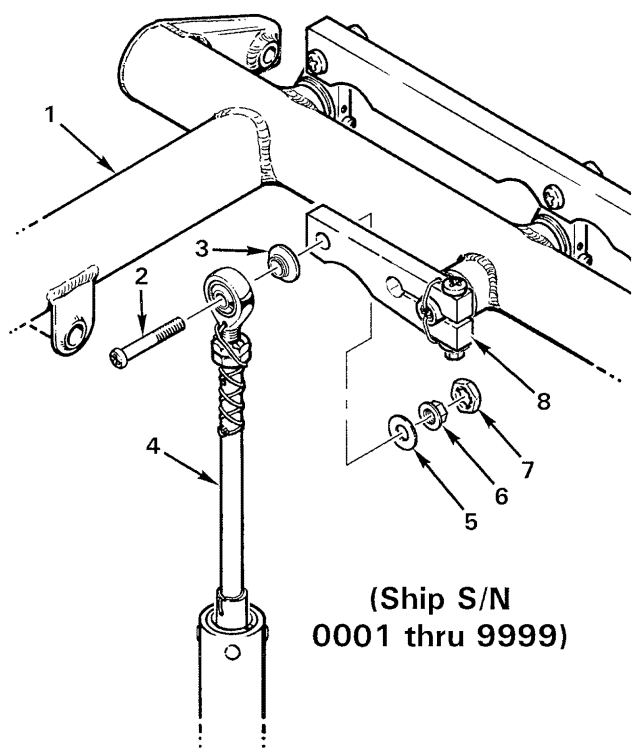

FIGURE 8-6 UPPER OVERTRAVEL SPRING INSTALLATION

NUMBER	PART NUMBER	DESCRIPTION
1	C758	Collective Assembly
2	A486-1	Screw
3	A341-1	Spacer
4	A327-1	Overtravel Spring Assembly
5	NAS1149F0332P	Washer
6	MS21042L3	Nut
7	B330-7	Palnut
8	C342-1	Arm Assembly
9	A486-4	Screw
10	C341-1	Arm Weldment

8.212 Collective Stick Installation (cont'd)

- e) Connect left support held in place by one upper MS37039C1-08 screw, AN960-10L washer and MS21042L3 nut. Install two lower MS27039C0806 screws, AN960-8L washers and MS21042L08 nuts.
- f) Install lower end of A333-1 stop to the C348-1 anchor. When installing A333-1 stop onto the A130-4 spacer, add AN960-416 and 416L washers on either side of stop as required to align stop with collective and to obtain 0.001 to 0.035 inch axial play. Torque nut per Section 1.320. Install palnut and check for binding and axial play.
- g) Connect C121-19 Push-Pull tube to collective. Torque NAS6604-9 bolt per Section 1.320.

CAUTION

The NAS6604-9 bolt at the forward end of the C121-19 push-pull tube must be installed so the bolt head is toward the left side of the helicopter. Refer to Figure 8-1.

- h) Connect governor motor plug to the connector.
- i) Remove the MT544-1 spring retainer from the collective spring assembly.
- j) Install the A327-1 overtravel spring to the collective arm (see Figure 8-6).

NOTE

Use special A486 screw and A341-1 spacer. With screw head against rod end ball, install spacer with large diameter against collective arm. Torque to 28 in.-lb plus nut drag and install palnut.

WARNING

Improper installation can cause binding, rod end damage or rod end separation with subsequent loss of engine throttle control.

- k) For rigging of throttle correlation, see Section 10.150.
- l) Verify all bolts and fasteners torqued.
- m) Install all panels.

8.213 Pilot-Adjustable Collective Friction (see Figure 8-5)

1. Loosen screw (6) on friction lever.
2. a. Manual controls - Hold friction lever knob 0.3-0.6 inch aft of full-forward position. Adjust screw (15) until washers (13) cannot be rotated with fingers then tighten friction lever screw (6).
b. Hydraulic flight controls - Hold friction lever knob fully aft against collective stick. Adjust screw (15) to produce a force of 18-22 pounds at collective grip, then tighten friction lever screw (6).

8.214 Fixed Collective Friction Adjustment (manual controls only, see Figure 8-3)

1. Remove vertical center panel between aft seatbacks.
2. a. Manual controls - see Figure 8-3. Tighten bolt (19) as required to eliminate feedback load through collective without being excessive.
b. Hydraulic flight controls - With carburetor heat LOCKED and pilot-adjustable collective friction fully off (zero friction), adjust NAS6606 bolt as required to produce 4-5 pounds (average of both directions) force at collective grip within servo deadbands.
3. Adjust pilot-adjustable collective friction per Section 8.213.

8.220 Collective Spring Assembly (manual controls only, see Figure 8-8)

The collective spring assembly is installed to balance the collective control forces produced in flight by the main rotor. The spring in the C038-5 or C038-6 spring assembly may be changed or adjusted to balance the collective control after main rotor blade change.

WARNING

When collective spring is compressed and retaining rings are installed, extreme care must be taken not to remove retaining rings unless suitable safety device is used to slowly relieve tension (see Figure 8-8).

8.221 Collective Spring Removal & Servicing

1. Remove aft vertical center panel between aft seat backs.
2. Place the collective in the full down position. Install 3 MS16633-2018 retaining rings in grooves on guide rods. If necessary, loosen locking nuts and rotate spring until grooves in guide rods are exposed. Carefully raise collective until retaining rings contact cap.

WARNING

Spring is under compression.

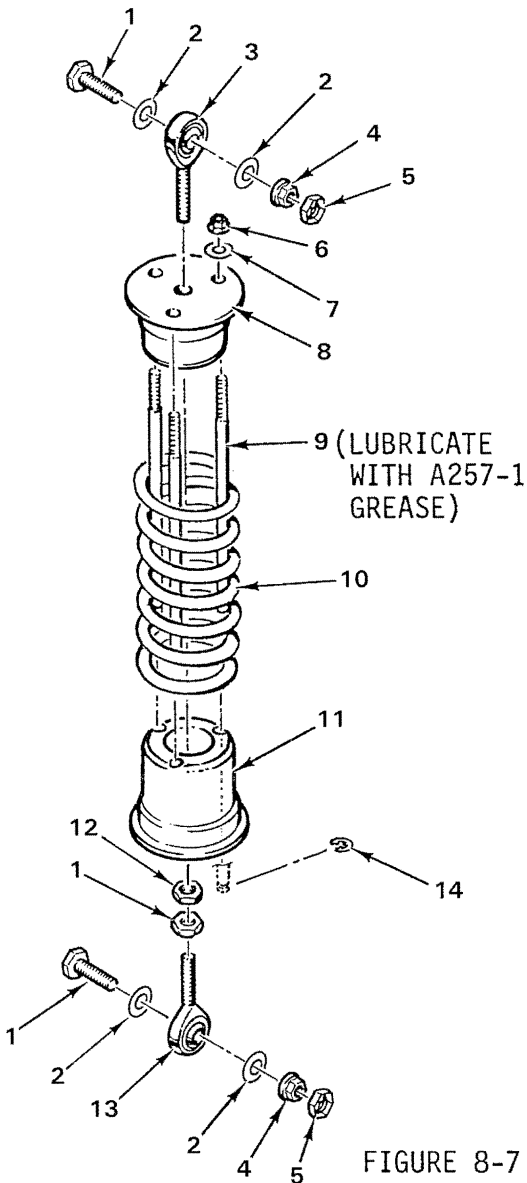

FIGURE 8-7 C038-5 AND -6 COLLECTIVE SPRING ASSEMBLY

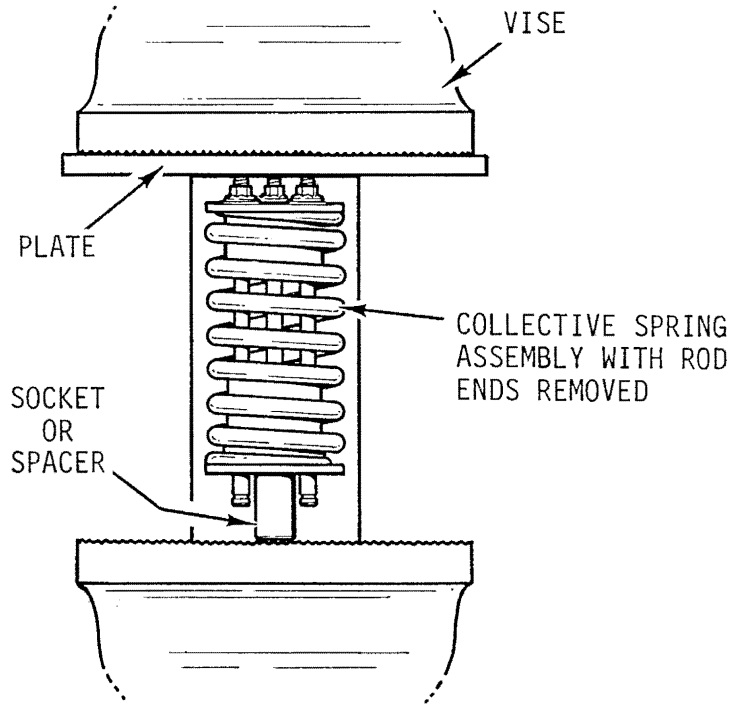

FIGURE 8-8
SUGGESTED METHOD
FOR RELIEVING
SPRING COMPRESSION

NUMBER	PART NUMBER	DESCRIPTION	NUMBER	PART NUMBER	DESCRIPTION
1	NAS6604-7	Bolt	10	A429-11	Spring (Strong; for C038-5 Assy)
2	AN960-416L	Washer		A429-12	Spring (Medium; for C038-6 Assy)
3	B292-4	Rod End (left-hand thread)		A429-13	Spring (Weak; for C038-7 Assy)
4	MS21042L4	Nut	11	C426-2	Cap
5	B330-13	Palnut	12	AN316-4R	Nut
6	MS21042L3	Nut	13	A127-4	Rod End
7	AN960-PD10L	Washer	14	MS16633-3018 (or -2018 or -1018)	Retaining Ring (used for removal and installation only)
8	C426-1	Cap			
9	C428-2	Rod			

8.221 Collective Spring Removal & Servicing (cont'd)

3. Remove bottom spring attach bolt.
4. Disconnect spring assembly upper attach bolt and remove spring assembly.
5. Remove rod ends from spring assembly and inspect. Verify threaded shanks are straight and play is with Section 2.120 limits.
6. Install spring assembly in vise per Figure 8-8. Remove retaining rings and decompress spring.
7. Clean C426-2 lower cap and inspect 0.194 inch diameter guide rod holes. Replace cap if holes are elongated, tapered, or greater than 0.204 inch diameter (a suitable size drill bit shank may be used as a go/no-go gauge).
8. Clean guide rods and inspect visible portions. Guide rods must be straight, cylindrical, and smooth. Replace guide rods if bent, tapered, worn or rough.
9. Lubricate guide rods with A257-1 grease (ref. Section 1.470) and reassemble spring assembly in reverse order.

8.222 Collective Spring Installation

WARNING

Install with nut end of guide rods pointing up (see Figure 8-7).

WARNING

When installing the C038 spring assembly, both rod ends must extend an equal number of turns (B292-4 rod end has left-hand thread). Failure to ensure both rod ends protrude equally can cause either one to run out of threads during adjustments and can cause bodily harm.

1. Connect B292-4 upper rod end to C427 support assembly and torque NAS6604 bolt per Section 1.320.
2. Move collective to align rod end into C326 bellcrank. Install bolt and torque per Section 1.320.
3. After installation of spring assembly, remove all three retaining rings from guide rods.

8.222 Collective Spring Installation (cont'd)

4. Verify coils are not binding with collective stick full down. Adjust spring assembly as required per § 8.223.

WARNING

Failure to remove retaining rings or allowing spring coils to bind can limit control travel.

5. Operate collective through its full range of travel and check for any interference or binding.
6. Install removed panels.

8.223 Collective Spring Adjustment

Small force adjustments may be made by extending or contracting overall length.

1. Secure collective fully down.
2. Remove panel between aft seatbacks.
3. Loosen palnut and jam nut on A127-4 rod end at bottom of spring assembly.
4. Rotate spring assembly to increase or decrease collective-up force (lower rod end is right-hand thread and upper rod end is left-hand thread). Extending rod ends increases collective-up force; screwing rod ends in decreases collective-up force.
5. Standard torque jam nut per § 23-32.

WARNING

Ensure spring coils do not touch with collective full down after making adjustment. Spring coils that touch can limit flight control travel.

6. While observing collective spring, move collective fully up and down and verify no interference.
7. Install removed panels.

8.230 RPM Governor System

The governor maintains engine RPM by sensing changes and applying corrective throttle inputs through a friction clutch which can be easily overridden by the pilot. The governor is active only above 80% engine RPM and can be switched on or off using the toggle switch on the end of the right seat collective.

The governor is designed to assist in controlling RPM under normal conditions. It may not prevent over- or under-speed conditions generated by aggressive flight maneuvers.

CAUTION

When operating at high density altitudes, governor response rate may be too slow to prevent overspeed during gusts, pull-ups, or when lowering collective.

8.231 Governor Controller Removal

WARNING

No external adjustment of controller is available. If controller fails to operate correctly, remove and return it to RHC.

1. Remove left hand, aft backrest.
2. Turn battery switch off & pull out GOV (2 amp) circuit breaker on circuit breaker panel.
 - a. D270-1 Governor controller: Loosen screws and disconnect airframe harness connector from governor controller; disconnect 1598-01C cable from governor controller. Cut and discard ty-raps as required and disconnect MAP line from governor controller.
 - b. D278 Governor controller: Disconnect airframe harness connector from D278 governor controller.
3. Remove hardware securing governor controller to C679-3 (LH) cover and remove governor controller.
4. Remove 40-4-2-N-0 elbow from D270-1 governor controller, as required.

8.232 Governor Controller Installation

CAUTION

Earlier R44-series helicopters that are not equipped with D270-1 governor controller / engine monitoring unit use a D278 governor controller. R44 helicopters require the D278-1 controller; R44 II helicopters require the D278-2 controller.

1. Turn battery switch off & pull out GOV (2 amp) circuit breaker on circuit breaker panel.
2. If D270-1 governor controller does not have 40-4-2-N-0 elbow installed, apply light coat B270-6 sealant to elbow threads (do not apply sealant to first thread) and install in governor controller finger tight. Continue tightening elbow to orient elbow perpendicular to governor controller data plate.
3. Install hardware securing D270-1 or D278 governor controller to C679-3 (LH) cover. Verify security.
4.
 - a. D270-1 Governor controller: Connect airframe harness connector to governor controller and tighten screws; connect 1598-01C cable to governor controller. Connect MAP line to governor controller and install ty-raps. Cinch ty-raps until snug without over-tightening and trim tips flush with heads.
 - b. D278 Governor controller: Connect airframe harness connector to D278 governor controller.
5. Push in GOV (2 amp) circuit breaker on circuit breaker panel.
6. Install left hand, aft backrest.

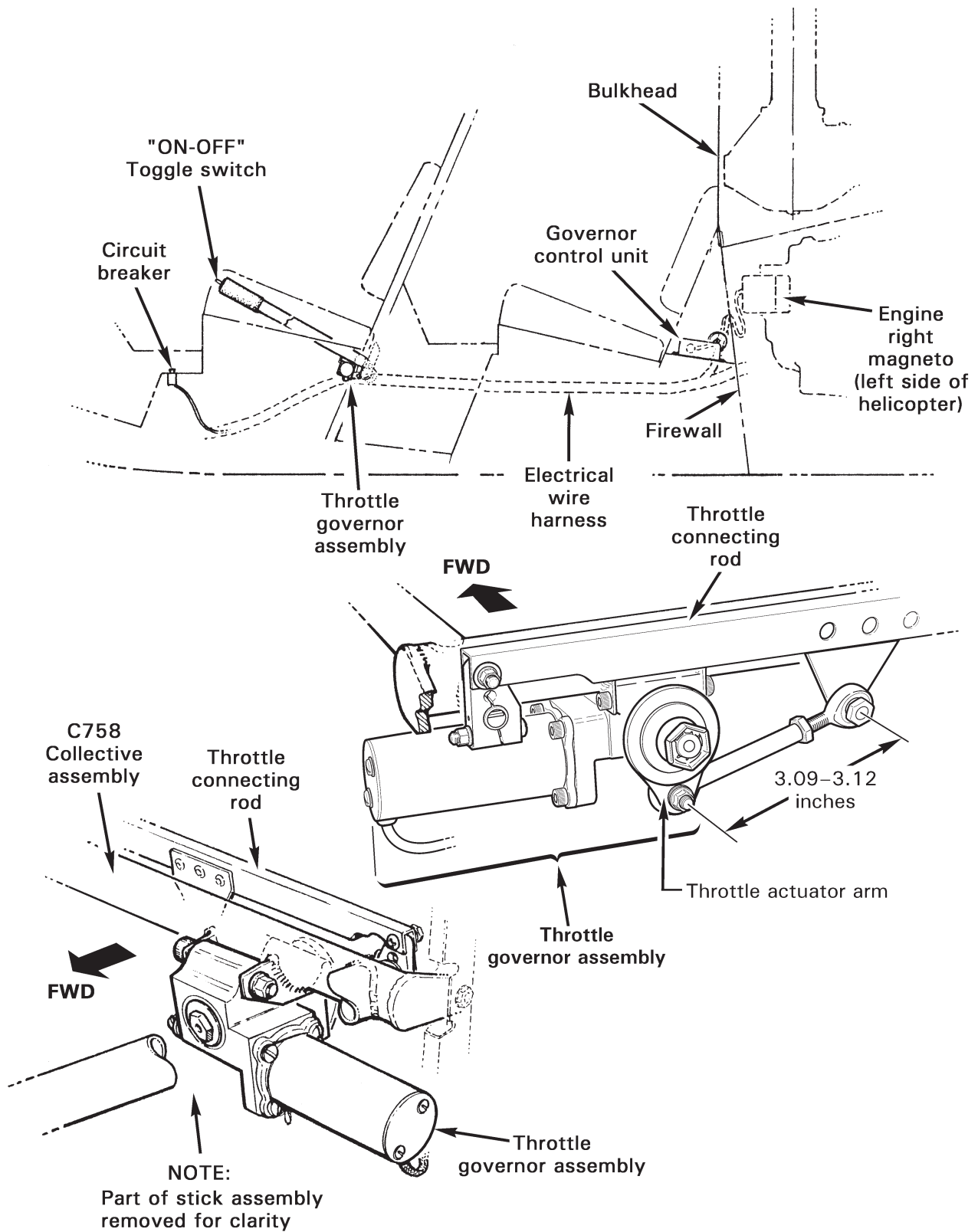

FIGURE 8-8A THROTTLE GOVERNOR INSTALLATION

8.233 Governor Assembly Removal

The governor assembly is attached to the collective stick behind the left forward seat.

WARNING

No adjustment of the friction clutch is permitted. No replacement of the gear motor is permitted. If the friction setting is incorrect, or the gear motor operates incorrectly, remove the complete assembly and return to RHC.

- a) Remove collective stick assembly per § 8.211.
- b) Remove the NAS6603-6 bolt from the connecting rod.
- c) Remove on NAS1351-4-28P screw and NAS1291-4 nut.
- d) Cut safety wire and remove two AN503-8-4 screws.
- e) Remove B247-5 governor assembly.

8.234 Governor Assembly Installation

- a) Connect the connecting arm to the governor assembly.

NOTE

DO NOT change the length on the connecting rod. The rod ends center-to-center distance should be 3.09–3.12 inches.

- b) Install two AN960-10L washers, one between rod end and governor motor arm and one under the nut. Torque nut and palnut per § 23-32.
- c) Install the NAS1351-4-28P screw and torque per § 23-32.
- d) Install the two AN503-8-4 screws and torque to 27 in.-lb and safety wire with 0.020 inch diameter safety wire.
- e) Install collective stick per § 8.212.

8.239 Governor Troubleshooting

A. D278-1 & D278-2 Governor Controllers

The majority of governor problems are caused by the engine-right (helicopter left side) magneto's tachometer contact assembly (points) being out of adjustment or faulty. Refer to TCM Master Service Manual for tachometer contact assembly installation and adjustment.

NOTE

When checking contact assembly gap, always check gap twice (i.e. with cam follower resting at each cam lobe apex). If allowable gap tolerance cannot be maintained at each cam lobe apex, submit magneto to an authorized repair facility.

When switched on, the governor is active from 80% to 112% engine rpm. Below 80% and above 112% engine rpm the governor will take no action.

When operating in the active range, the governor will attempt to maintain engine rpm at approximately 102% \pm 0.5% (D278-1 controller) or \pm 0.75% (D278-2 controller). The edges of this governed rpm window – called a “deadband” – may be detected when the helicopter is in stable (no gusts), straight and level flight as follows:

1. Gently hold throttle and very slowly increase rpm (do not exceed 104%). Note and record engine rpm indication when governor input (subtle throttle resistance) is encountered.
2. Gently hold throttle and very slowly decrease rpm (do not go below 99%). Note and record engine rpm indication when governor input (subtle throttle resistance) is encountered.
3. Subtract second reading from first reading. Result should be approximately 1% (D278-1) or 1½% (D278-2).

A deadband not centered on 102% is indicative of a governor controller problem.

A wider-than-normal deadband, but still centered on 102%, is usually indicative of excessive throttle linkage friction and/or insufficient governor friction.

Check throttle friction by disconnecting overtravel spring assembly upper rod end from C341/C342 arm and attaching a spring scale to the rod end. With throttle arm in idle position, slowly pull up overtravel spring assy with spring scale and note maximum 4 pounds moving friction prior to full open throttle. Excessive throttle linkage friction can be caused by binding rod ends, control interference, carburetor throttle shaft bushing elongation, or binding carburetor accelerator pump (typically binds in one direction only).

8.239 Governor Troubleshooting (continued)

A. D278-1 & D278-2 Governor Controllers (continued)

Check governor friction with collective down, collective friction on, overtravel spring assy upper rod end disconnected from C341/C342 arm, and arm positioned horizontally. Attach a spring scale to hole in the arm and, with scale held tangential to arm, slowly pull on scale and note both the breakaway and the moving frictions. Breakaway friction is typically 0–0.5 pound greater than moving friction. Breakaway friction 1 pound or greater than moving friction may indicate damaged or contaminated governor friction clutch. Moving friction must be minimum 8 pounds until arm stops moving. Insufficient moving friction can be caused by wear, contamination, or loss of spring rate.

Proper governor operation requires a minimum 2:1 ratio of governor friction-to-throttle linkage friction.

Erratic operation is usually indicative of wiring damage or tachometer point problems. Wiring damage may be evidenced by crushing, pinching, or abrasion, all of which can result in grounding of one or both center wire conductor(s) to the shielding or to structure. Tachometer point problems may be caused by contamination (due to over-lubrication of magneto cam follower felt), oxidation (such as from an obstructed vent plug or leaking magneto drive seal), or loose contact(s), in addition to installation or assembly errors.

When flying in turbulence, or if the engine is lightly “loaded” (drive train almost freewheeling) a fluctuating MAP indication is expected.

Any loose connection in throttle linkage (including worn carburetor throttle shaft bushings) will result in both RPM & MAP oscillations.

8.300 Jackshaft and Support Struts

8.310 Jackshaft (See Figure 8-9)

8.311 Jackshaft Removal

NOTE

Rigging check is not necessary if jackshaft support strut rod ends and push-pull tube rod ends are not moved.

- a) Disconnect the push-pull tubes from the jackshaft.
- b) Disconnect the two jackshaft support bolts at the upper support rod ends.
- c) Remove jackshaft.

8.312 Jackshaft Installation

- a) Install jackshaft to strut rod ends. Aft support rod end requires a C141-1 safety washer between the rod end ball and bolthead.
- b) Torque nuts per § 23-32 and install palnut.
- c) Connect the C121-3 and -5 push-pull tubes to jackshaft. Both push-pull tube attach boltheads point forward. The forward C121-3 push-pull tube rod end requires a C141-1 safety washer and C115-1 spacer between the rod end and bolthead. The aft C121-5 push-pull tube rod end requires a C141-1 safety washer between the rod end and bolthead.
- d) Torque nuts per § 23-32 and install palnut.
- e) Verify no binding or interference with control system exists throughout flight control travel.

8.320 Strut Assembly (Jackshaft Support)

8.321 Jackshaft Strut Removal

- a) Remove jackshaft per § 8.311.
- b) Remove the support struts from the main rotor gearbox fittings. Disconnect the aft vertical strut upper rod end to release the aft strut from the C345-1 strut weldment.

8.322 Jackshaft Strut Installation (see Figure 8-9)

- a) Install lower rod ends to the main rotor gearbox fittings as shown in Figure 8-9.
- b) Reinstall the aft vertical strut upper rod end as shown in Figure 8-9. The rod end extension must be set to 0.93 ± 0.03 inch from the end of the strut to the center line of the rod end ball. (The dimension is the same for all six support rod ends.)
- c) Install jackshaft and push-pull tubes per Section 8.312.
- d) Verify that all bolts and jam nuts are torqued per Section 1.320.

JACKSHAFT INSTALLATION

NUMBER	DESCRIPTION
1	Jackshaft Assembly
2	Rod End
3	Washer
4	Nut
5	Palnut
6	Washer
7	Washer
8	Bolt
9	Palnut
10	Nut
11	Bolt
12	Bolt
13	Spacer
14	Washer
15	Tube Weldment
16	Nut
17	Rod End
18	Bolt
19	Washer
20	Nut
21	Palnut
22	Fitting
23	Washer
24	Strut Weldment
25	Spacer
26	Washer (Ref)
27	Push-Pull Tube Assembly (Ref)
28	Push-Pull Tube Assembly (Ref)

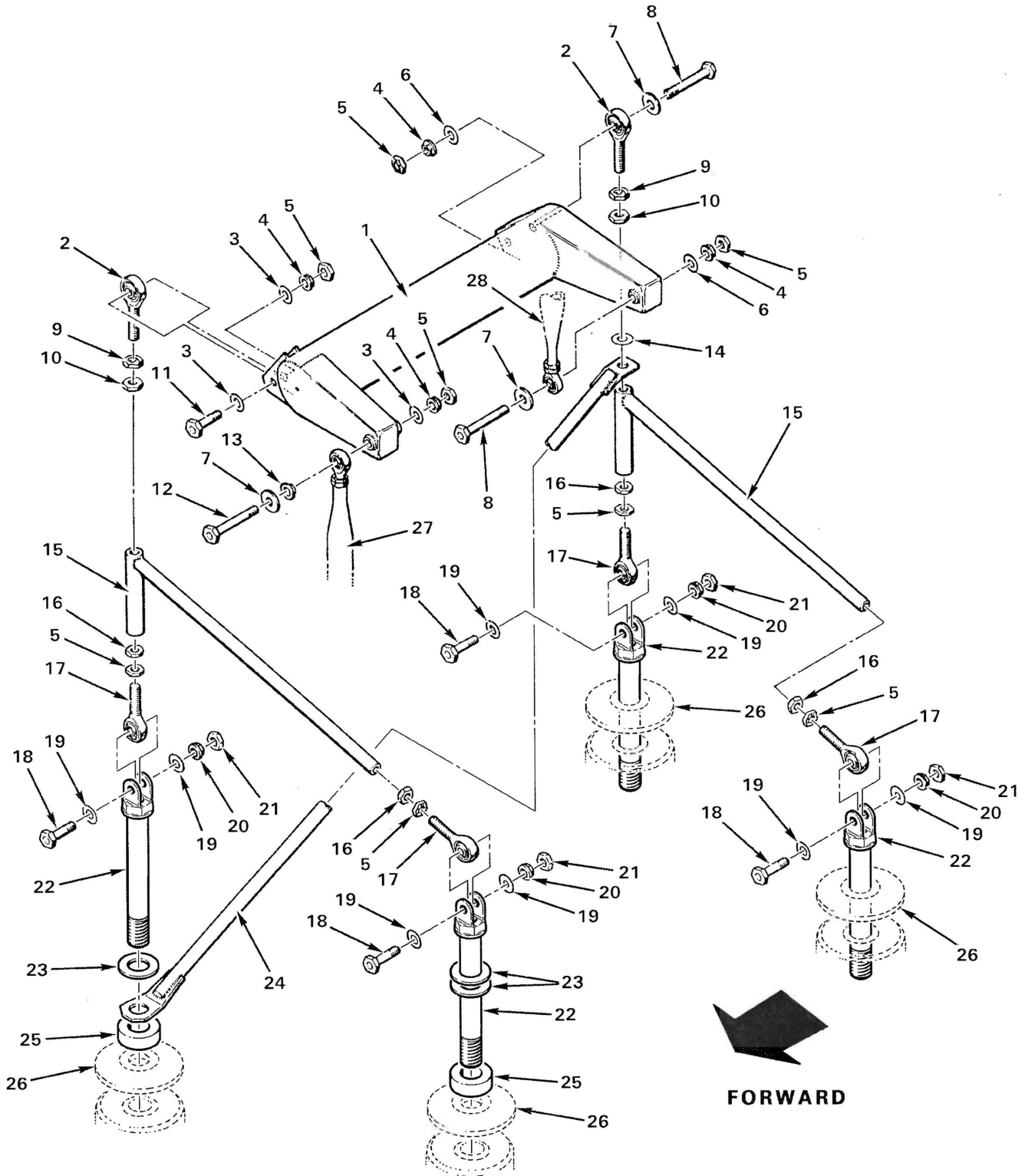

FIGURE 8-9 JACKSHAFT INSTALLATION

8.400 SWASHPLATE AND MAIN ROTOR PITCH LINKS

8.410 Swashplate

8.411 Swashplate Removal

NOTE

Rigging check is not required if push-pull tube rod end center-to-center dimension does not change.

1. Remove main rotor blades and hub per Sections 9.111 and 9.121.
2. Remove droop stops and teeter stops.
3. Disconnect upper C204 arm at C203 yoke.
4. Disconnect and remove C203 yokes and A210 key.
5. Remove swashplate boot by cutting plastic ty-raps.
6. Disconnect three push-pull tubes and rod end of lower forward A205 fork assembly from lower (non-rotating) swashplate.
7. Lift swashplate with attached fork and pitch links off slider tube.

8.412 Swashplate Installation (see Figure 8-10)

WARNING

R44 II (fuel injected) helicopters require two A205-7 forks, A600-6 manifold pressure gage, two C005-8 main rotor blade & spindle assemblies (two C016-5 main rotor blades & two C157-2 pitch horns), C006-5 main rotor gearbox, C008-4 tail rotor assembly (two C029-2 tail rotor blades), two C016-5 main rotor blades, C017-4 swashplate, three C121-31 push-pull tubes, two C203-5 yokes, C204-2 arm (stainless steel, lower), C204-3 arm (stainless steel, upper), C792-4 dual tachometer, D201-5 support weldment (forward hydraulic servos), and D204-8 support weldment (aft hydraulic servo).

1. Install swashplate onto slider tube assembly. Connect lower scissors' fork to left side of middle of three lugs on lower, non-rotating swashplate. Connect aft push-pull tube to right side of aft, single lug on lower swashplate. Torque per Section 1.320 and install palnuts.
2. Verify swashplate tilting friction per Section 8.413; adjust as required.
3. Slide swashplate boot over main rotor drive shaft and set in place.
4. Refer to Figures 8-13, 8-13A and 8-13B. Install C203 yokes on main rotor drive shaft upper flange using A210 key to index yokes to shaft. Finger tighten clamping hardware.

8.412 Swashplate Installation (cont'd)

NOTE

Round edge of A210 key to fit into slot in flange on C251 drive shaft.

5. Torque yoke clamping bolt securing A210 key first per Section 1.320 and install palnut.
6. If yoke clamping bolt opposite A210 key is an NAS6605 bolt, special torque per Section 1.330 and install palnut. If bolt is an NAS6604 bolt, torque per Section 1.320 (standard torque) and install palnut. A slight gap between yokes opposite A210 key is normal.
7. Install chord arm weights, if any. Torque per Section 1.320 and install palnut.
8. If required, fill remainder of rod end threaded hole in upper A205 fork with B270-4 or B270-13 sealant (see Section 1.480).
9. Refer to Figures 8-13 & 8-13A. Install upper A205 fork and C204 arm on C203 yoke and torque per Section 1.320. Verify pivot frictions on upper scissors are less than 5 inch-pounds with hydraulic controls, or less than 2.5 inch-pounds with manual controls; as required, replace bearings per Section 8.600 or change shim thickness. Verify bolt, arm, and clamped hardware in upper scissor's pivots rotate together. Install palnuts.
10. Verify bolt, arm, and clamped hardware in lower scissor's pivots rotate together. Connect forward push-pull tube rod ends to remaining lower lugs on swashplate. Torque per Section 1.320 and install palnuts.
11. Connect upper A205 fork rod end and lower rod end of C258 pitch link to interrupter-side swashplate ear. Torque per Section 1.320 and install palnut.
12. Position swashplate boot on rotating swashplate with inner lip contacting C203 yoke. Secure with ty-raps.
13. Attach two A255-3 counterweights and lower rod end of C258 pitch link to swashplate ear opposite interrupter. Torque per Section 1.320 and install palnut.
14. Install main rotor hub and blades per Sections 9.122 and 9.112.
15. Verify safety washers and C115 spacers installed on all rod ends per Figure 2-1. Torque stripe fasteners per Figure 2-1.
16. Verify no interference with control movement throughout flight control travel and swashplate movement corresponds with cyclic and collective movement.
17. Track and balance main rotor per Section 10.230.

SWASHPLATE ASSEMBLY

NUMBER	DESCRIPTION	NUMBER	DESCRIPTION
1	Bolt	22	Washer
2	Washer	23	Rod End
3	Counterweight (1.10 inch O.D.)	24	Boot
	Counterweight (1.90 inch O.D.)	25	Pitch Link (incl items 23, 32-34, 36 & 37)
4	Nut	26	Bolt
5	Palnut	27	Ty-rap
6	Bolt	28	Bolt
7	Washer	29	Ty-rap
8	Nut	30	Swashplate Assembly
9	Palnut	31	Bolt
10	Yoke Assembly (2 Req'd)	32	Palnut
11	Washer	33	Nut
12	Washer	34	Fitting
13	Bolt	35	Bolt
14	Washer	36	Link Assembly
15	Key	37	Nut
16	Bearing	38	Interrupter
17	Spacer or Journal	39	Rivet
18	Arm	40	Arm
19	Bolt	41	Counter Weight (0.70 inch O.D.)
20	Fork Assembly	42	Rivet (one per C258-4 Link Assembly)
21	Spacer	43	Link

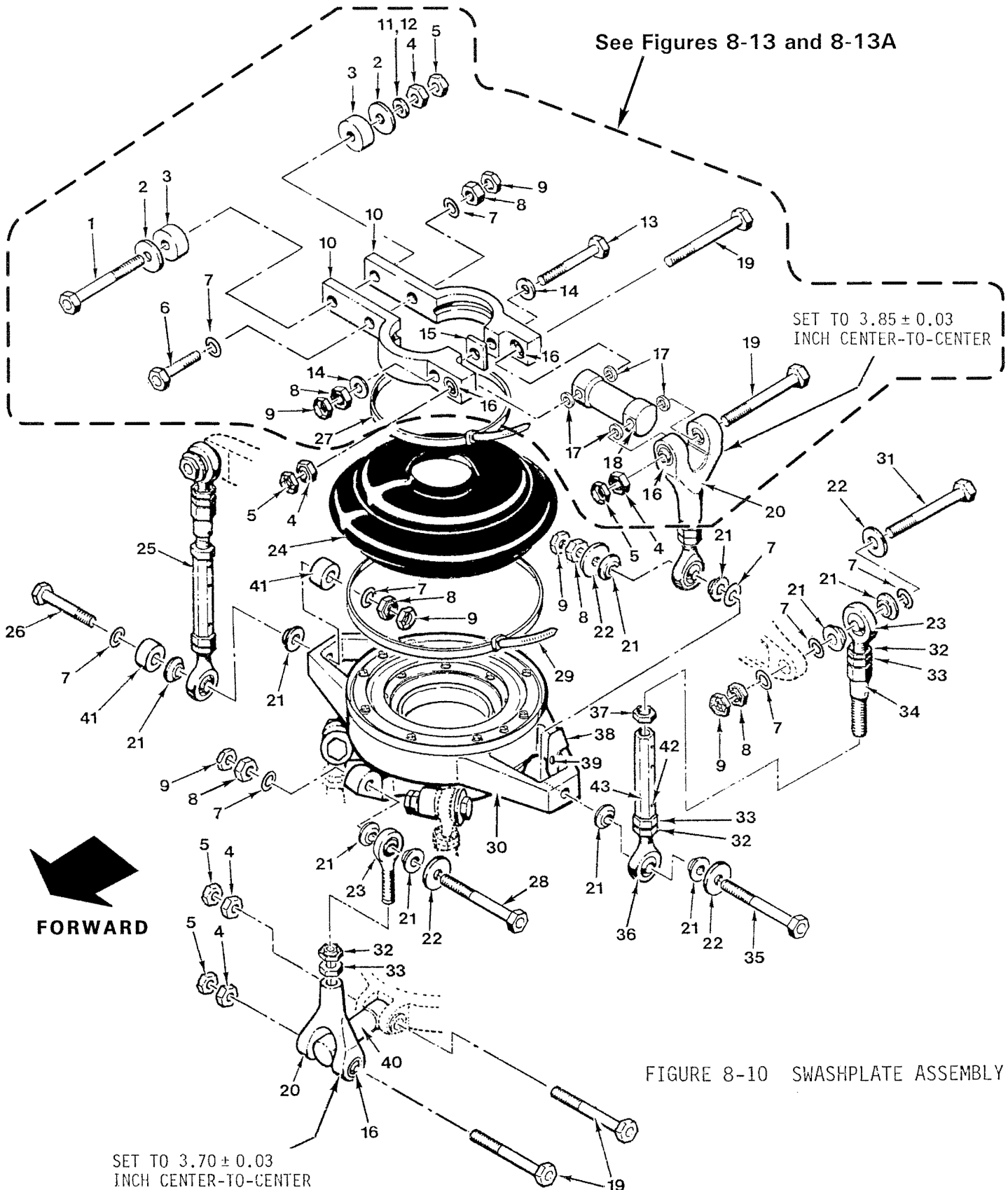

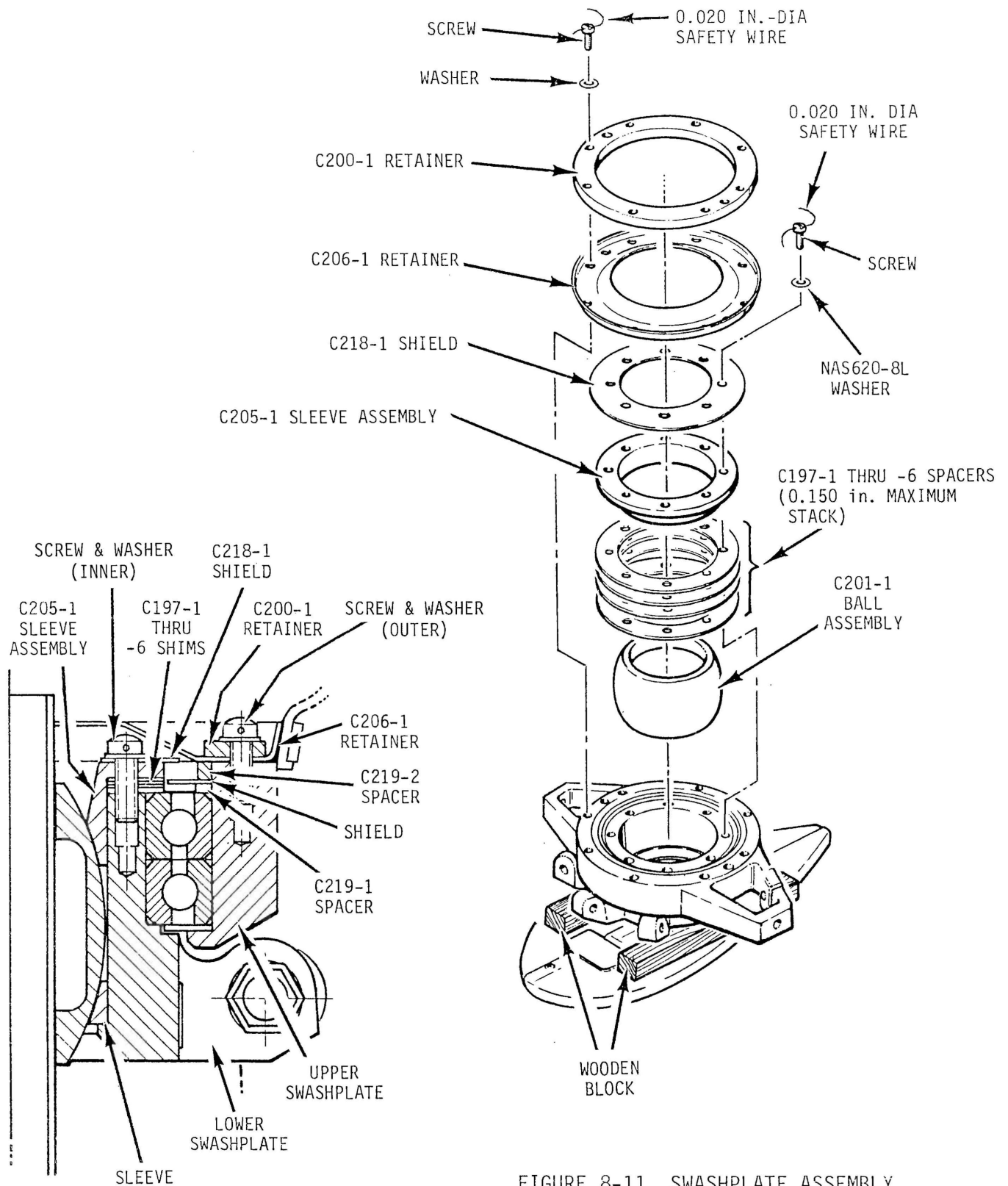

FIGURE 8-11 SWASHPLATE ASSEMBLY

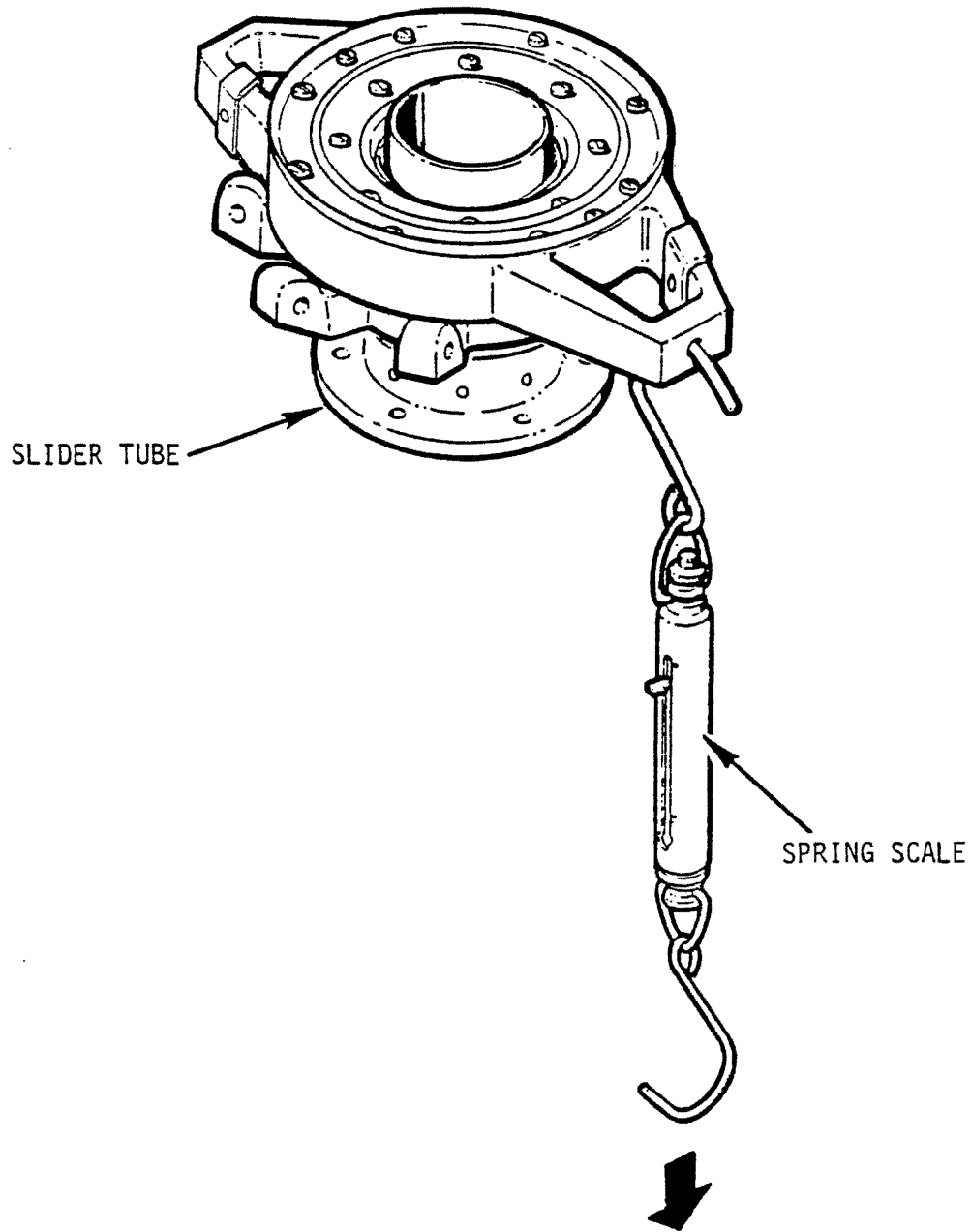

FIGURE 8-12 MEASURING SWASHPLATE TILTING FORCE

8.413 Swashplate Tilting Friction Adjustment

Swashplate tilting friction is established by C197-1 through C197-6 spacers controlling clamping force of Teflon-lined sleeves on the ball assembly.

1. Mark for reassembly and disconnect boot, pitch links and drive linkage (scissors) from upper swashplate and both forward push-pull tubes from lower swashplate
2. Align upper swashplate arms with lateral axis of helicopter and center cyclic stick. Using MT359-1 spring scale (or equivalent) connected to upper swashplate arm bolt hole per Figure 8-12, pull down and note scale reading while swashplate is moving; do not use breakaway reading. Force required to tilt swashplate must be free-without-looseness minimum to 5 pounds maximum.
3. To adjust friction, remove outer screws from upper swashplate and raise and secure retainers to allow access to inner screws. Remove inner screws securing sleeve to lower swashplate.
4. Raise sleeve and measure thickness of C197 spacer stack. Adjust spacer stack thickness as required, but not exceeding 0.150 inch, to achieve proper tilting friction. Decreasing spacer stack thickness increases tilting friction while increasing spacer stack thickness decreases tilting friction. All inner screws must be installed and torqued per Section 1.330 prior to measuring friction.
5. Safety wire inner screws with 0.020 inch diameter safety wire. Secure retainers to upper swashplate with outer screws, torque per Section 1.330, and safety wire.
6. Connect both forward push-pull tubes to lower swashplate, torque per Section 1.320, and torque stripe.
7. Connect both pitch links and drive linkage to upper swashplate (interrupter on same side as drive linkage), torque per Section 1.320, and torque stripe.

8.500 TAIL ROTOR CONTROLS

8.510 Tail Rotor Pedals

8.511 Tail Rotor Pedal Removal

1. Soak both front floor carpets with Prep-sol for 15-20 minutes, then lift carpet carefully from the floor on both sides and remove from the cabin. Caution: This is a flammable material. Follow manufacturer's safety precautions to prevent injury.
2. Remove the screws between the pedals holding the access plates to the floor and remove the plates.
3. Lift the console and disconnect the intercom system controller and the outside air temperature gauge wiring.
4. Remove radios, radio face plate and the radio rack by removing the screws which secure it to the sides of the console.

8.511 Tail Rotor Pedal Removal (cont'd)

5. Disconnect both pedal assemblies from the C343-3 and C343-5 push-pull tubes by removing two NAS6604-9 bolts.

CAUTION

DO NOT remove the rod ends or change the length of the push-pull tubes.

6. Remove six NAS6603-20 bolts (three per side) which hold the A318-1 and -2 bearing block halves together.
7. Remove the lower bearing block halves.
8. Remove the tail rotor pedals one at a time by lifting one end and allowing the other to drop into the chin. They can be removed from either the right or the left side.

NOTE

On reassembly, the right pedal assembly is mounted forward in the bearing blocks and the left is mounted aft.

NOTE

Pedal blocks (upper and lower) are a machined matched set as indicated by matching letter or number on the upper and lower portion of blocks. DO NOT mix them or alignment problems may develop on installation.

8.512 Tail Rotor Pedal Installation

1. Fill the grooves in the pedal bearing blocks with A257-1 grease.
2. Install the pedal assemblies into the bearing blocks and torque the bearing block attach bolts per Section 1.320.

NOTE

If a force greater than 5 lbs is required to move pedals, check the bearing blocks to ensure they are matched correctly.

3. Connect both pedal assemblies to the push-pull tubes and torque the NAS6604-9 bolts to per Section 1.320 and install palnuts.
4. Install radio racks, radios and radio panel face plate.
5. Move the pedals through the full range of travel to ensure there is no interference or binding.
6. Secure console. Install the pedal cover plates and carpeting. Use B270-7 or -8 adhesive to attach carpeting.

8.520 C317 Lower Bell Crank

8.521 C317-2 Lower Forward Bell Crank Removal

- a) Remove two screws securing the upper console. Lift up the console and disconnect intercom system controller and outside air temperature gauge wiring.
- b) Remove radios, radio panel face plate and the radio rack which is secured with screws to the side panels.
- c) Disconnect forward C343-3 and C343-5 push-pull tubes and aft C121-9 push-pull tube from the bell crank by removing all three NAS6604-9 bolts.
- d) Remove four MS27039C0807 screws which secure the C349-1 support assembly to the forward keel panel.
- e) Remove support and bell crank assembly from the ship.
- f) Remove NAS6604-19 bolt which connects the bell crank to the support. Remove bell crank.

8.522 C317-2 Lower Forward Bell Crank Installation

This procedure also covers rigging of the lower push-pull tubes and pedal assemblies. If re-checking of rigging is not required, disregard rigging portions and follow installation sequences.

- a) Install two A105-3 journals inside C317-2 bell crank. Place one A141-3 washer against the outside ends of the A105-3 journals upon assembly to the support.

Tighten pivot nut and check for smooth and free operation. Maximum spring scale drag of 2 lbs is acceptable to move the bell crank. Torque per Section 1.320.

If a force in excess of 2 lb is required to move the bell crank measure the distance between the A141-3 washers with the washers held tightly against the journals. Using a one inch diameter spotface tool with a 0.250 inch pilot in one A105-3 journal, lightly shave the outside face of each bearing 0.002 inch - 0.003 inch at a time. Assemble the bell crank on the support assembly. If a force in excess of 2 lb is required to move the bell crank, repeat above step.

- b) Install the support assembly in the ship and secure it to the keel panels with four MS27039C0807 screws. Adjust the length of C343-3 push-pull tube rod ends center-to-center to 4.42 inch and adjust C343-5 rod ends center-to-center to 6.45 inch. Verify that the rod ends are engaged sufficiently by checking the witness holes with a piece of 0.020 inch safety wire.

8.522 C317-2 Lower Forward Bell Crank Installation (cont'd)

Connect all three push-pull tubes to C317-2 bell crank. Do not torque the NAS6604-9 bolts yet. The length of C121-9 push-pull tube must be set to 66.0 inch. Ensure the 121-9 push-pull tube is installed through the center of the C346-1 restraint at the mid span position.

The vertical C343-1 push-pull tube which connects C317-1 aft bell crank to C316-1 upper bell crank must measure 13.40 in. rod end center-to-center.

Connect fwd end of C121-9 push-pull tube to the C317-2 fwd bell crank and the aft end to C317-1 bell crank. Tighten the bolts but do not torque them yet. Connect one end of C343-1 push-pull tube to the C317-1 aft bell crank and the other end to C316-1 upper bell crank. Tighten the bolts but do not torque them yet.

Install a 3/16 inch diameter pin through the rigging hole located in the right aft passenger cargo compartment and push it through C317-1 bell crank's rigging hole. With rigging pin installed, adjust lengths of C121-9 and C343-3 push-pull tubes to obtain 2.90 in. between right pedal and right-hand stop.

After adjusting pedal travel, remove the rigging pin and apply full left pedal. With left pedal at stop, adjust length of C343-1 to obtain 0.10 - 0.20in. from C121-15 forward rod end to bulkhead. With left pedal at stop, adjust length of C121-17 push-pull tube to obtain 0.35 ± 0.03 inch between C031-1 pitch control assembly and face of the tail rotor gearbox end cap. Check all push-pull tube rod ends witness holes for engagement.

NOTE

It is permissible for the bell crank arm to touch and deflect acoustical foam, as long as it does not interfere with free movement and full travel of the controls.

- c) Torque all attaching bolts per Section 1.320. Install palnuts and torque stripe fasteners.

8.522 C317-2 Lower Forward Bell Crank Installation (cont'd)

- d) Check for smoothness and ease of operation. Move pedals full travel. Check for any interference between tubes, wires and structure.
- e) If required, check complete tail rotor rigging if changes to C343-1, C343-3, C343-5, C121-9, C121-15 or C121-17 push-pull tube lengths have been made.
- f) Verify all attach bolts and jam nuts torqued per Section 1.300.
- g) Install radio rack, radio face plate, radios and all the panels which were removed.

8.523 C317-1 Lower Aft Bell Crank Removal

- a) Install collective spring retainer or safety wire the collective spring per Section 8.221.
- b) Remove collective spring per Section 8.221.
- c) Disconnect C121-9 and C343-1 push-pull tubes by removing respective NAS6604 bolts from the C317-1 bell crank.
- d) Disconnect A205-3 fork assembly from the C326-1 bell crank assembly by removing NAS6604-38 bolt. Leave friction assembly connected to C315-1 upper support.
- e) Remove NAS6604-9 bolt and disconnect C121-19 collective push-pull tube from the C326-1 bell crank.
- f) Remove four NAS6604-2 bolts which are securing C315-1 rear support assembly to the left and right panels. Remove C334 assembly.
- g) C317-1 aft bell crank is connected to rear support assembly by C311-1 bolt which is common to C317-1 to C326-1 bell cranks. Remove the bolt and remove C317-1 aft bell crank.

8.524 C317-1 Lower Aft Bellcrank Installation

- a) Install C317-1 aft bellcrank on C315-1 or C315-7 rear support assembly with NAS6604-105 bolt, one NAS1149F0432P washer under head and two NAS1149F0463P washers under nut. Standard torque bolt per Section 1.320, install & torque palnut, and torque stripe per Figure 2-1.
- b) Install C334 rear support assembly in ship and secure it to side panels with four NAS6604-2 bolts. Standard torque bolts per Section 1.320, and torque stripe per Figure 2-1.
- c) Connect C343-1 and C121-9 push-pull tubes to the C317-1 tail rotor control aft bellcrank. Connect the C121-19 push-pull tube to C326-7, C326-8, or C334-4 bellcrank. Verify A697-6 tab oriented 0° to 20° outboard from vertical. Standard torque bolt per Section 1.320, install & torque palnut, and torque stripe per Figure 2-1.
- d) Set upper A205-3 fork assembly center-to-center distance to 3.80 inch \pm 0.03 inch. Reconnect A205-3 fork assembly to C326-7, C326-8, or C334-4 bellcrank.
- e) If applicable, set collective-friction rod end link assembly center-to-center to 2.300 inches \pm 0.010 inch (C327-1 collective-friction link assembly is not adjustable). Install bolts and standard torque per Section 1.320. Install & torque palnuts, and torque stripe per Figure 2-1.
- f) If applicable, connect bottom rod end of collective spring assembly to C326-7, or C326-8 support assembly per Section 8.222. Standard torque bolt per Section 1.320, install & torque palnuts, and torque stripe per Figure 2-1. Remove retainer from spring.
- g) Move pedals and check for smoothness and ease of operation. Move pedals, collective, and cyclic full travel, and verify no interference between tubes, bellcranks, wires and structure.

8.530 C316-1 Upper Bellcrank

8.531 Bellcrank Removal

- a) Remove aft vertical panel between seat backs and right rear seatback.
- b) Disconnect C343-1 push-pull tube from the bellcrank assembly by removing the NAS6604-8 bolt.
- c) Disconnect C121-15 push-pull tube from C316-1 bellcrank by removing NAS6604-8 bolt.
- d) Disconnect C316-1 bellcrank from aircraft by removing NAS1304-17 bolt from inboard support and NAS6604-11 bolt from outboard support.

8.532 Bellcrank Installation

- a) Install bellcrank with NAS1304-17 bolt through bearing block and then through bellcrank and NAS6604-11 bolt connecting bellcrank to outboard support. Torque bolts per Section 1.320. Install palnuts, torque per Section 1.320 and torque stripe per Figure 2-1.
- b) Reconnect forward end of C121-15 push-pull tube and upper rod end of C343-1 push-pull tube to C316-1 bellcrank. Torque bolts per Section 1.320. Install palnuts, torque per Section 1.320 and torque stripe per Figure 2-1.

NOTE

If rod ends, of C121-15 and C343-1 push-pull tubes, were removed or length of push-pull tubes were altered re-rig tail rotor blades per Section 10.140.

8.540 A331-4 Intermediate Bellcrank (See Figure 8-14)

8.541 Bellcrank Removal

- a) Disconnect C121-15 and -17 push-pull tubes from A331-4 bellcrank.
- b) Disconnect NAS6604-35 attach bolt and remove bellcrank.

8.542 Bellcrank Installation

- a) Install two A105-3 journals into bellcrank bearings. One A141-3 washer is required on each side of bellcrank against A105-3 journals (If required, ream A139-1 bearing with 0.375/0.376 in. dead-sharp reamer for journal's smooth installation).
- b) Install bolt and torque per Section 1.320. Install palnut, torque per Section 1.320 and torque stripe per Figure 2-1.
- c) Check for smoothness and ease of operation.
- d) Connect A121-15 and -17 push-pull tubes. A214-3 safety washer is required under the bolt head which connects C121-15 push-pull A331-4 tube to the bellcrank and one MS20002-4 washer is required between the rod end ball and the bellcrank.
- e) A214-3 safety washer is required between bolt head and forward rod end of C121-17 push-pull tube.
- f) Re-rig tail rotor per Section 10.140 if push-pull tube lengths were altered.

8.542 Bell Crank Installation (cont'd)

- e) Move pedals full travel, check for any interference between tubes, wire, components or structure.

8.550 A120-3 Aft Bell Crank**8.551 Bell crank Removal**

- a) Disconnect C121-17 push-pull tube from A120-3 aft bell crank.
- b) Disconnect bell crank pivot from attach bolt connected to tail rotor gearbox.
- c) Remove nut holding bell crank to the pitch control. Remove bell crank and reinstall nut and shims found between bell crank and pitch control for bell crank installation.

8.552 Bell Crank Installation

See C031-1 Pitch Control Installation (see Section 8.562).

8.560 C031-1 Pitch Control**8.561 Pitch Control Removal**

- a) Remove tail rotor hub and blade assembly. Mark corresponding tail rotor blade grips, tail rotor pitch change to each of the pitch control ears, for later reinstallation so re-rigging is not required.
- b) Disconnect and remove A120-3 aft bell crank per Section 8.551.
- c) Remove C031-1 pitch control from tail rotor output shaft.

8.562 Pitch Control Installation

- a) Slide C031-1 pitch control assembly onto output shaft.
- b) Position A120-3 bell crank assembly on the tail rotor gearbox and install NAS6604-25 bolt, one AN960-416L washer under bolt head, two MS20002-4 washers, one on each side of the bearing and MS21042-4 nut. Tighten but don't torque at this time.
- c) Measure the gap existing between the A120-3 bell crank ear and the flats on the C125-1 pitch control stud. Install sufficient C117-34, -35 and -36 washers between bell crank and stud to completely fill the gap but not apply any axial preload on the spherical bearing after all the nuts are tightened. The clearance tolerance is ± 0.003 ". Install one AN960-516L washer and MS21042-5 nut on protruding end of stud. Torque nut to 200 in.-lb plus nut drag while holding stud from rotating, and install palnut.

8.562 Pitch Control Installation (cont'd)

- d) Torque nut on A120-3 bellcrank pivot per Section 1.320 and install palnut.
- e) Attach aft end of C121-17 push-pull tube to the A120-3 bellcrank with NAS6604-10 bolt, AN960-416L under head, and A214-3 safety washer under nut next to rod end. Torque nut per Section 1.320 and install palnut.
- f) Install pitch control links per Section 8.572.
- g) Install tail rotor hub and blade assembly (see Section 9.212).
- h) Ensure all bolts, jam nut and palnuts are torqued per Section 1.300.

8.570 Tail Rotor Pitch Links**8.571 Tail Rotor Pitch Link Removal****NOTE**

To ensure proper rigging upon reinstallation of pitch links, mark pitch links to corresponding blade grip and pitch control ear.

- a) Disconnect the two attach bolts on both rod ends of the pitch link.
- b) Remove pitch link.

8.572 Tail Rotor Pitch Link Installation**WARNING**

A214-3 safety washers are to be installed next to each rod end.

CAUTION

One-piece tail rotor pitch links must be used in sets. DO NOT use one-piece pitch links with adjustable pitch links.

NOTE

If installing same pitch links, match pitch link to proper blade grip and pitch control ear. If installing new, adjustable pitch links, measure overall length of old pitch link with micrometer or caliper. Adjust the new pitch link to the measurement obtained within 1/2 turn of the rod end.

8.572 Tail Rotor Pitch Link Installation (cont'd)**WARNING**

Both pitch links must be same part number (same type and material). Mixing one-piece with adjustable-length pitch links is prohibited. Mixing steel one-piece with aluminum one-piece pitch links is prohibited.

Refer to Figure 9-11.

A. If installing one-piece pitch link(s):

1. Connect pitch link to pitch control arm and blade pitch horn.
2. Torque attach bolts per Section 1.320. Install palnuts, torque per Section 1.320, and torque stripe per Figure 2-1. Repeat for opposite blade.

B. If installing new, adjustable-length pitch link(s) based on old pitch link length:

1. Match pitch link to proper blade pitch horn and pitch control arm and connect pitch link. Torque attach bolts per Section 1.320. Install palnuts, torque per Section 1.320, and torque stripe per Figure 2-1. Repeat for opposite blade.
2. Torque attach bolts per Section 1.320. Verify proper rod end centering and adjust as required. Install palnut, torque per Section 1.320, and torque stripe per Figure 2-1. Repeat for opposite blade.
3. Check tail rotor control rigging per Section 10.140.

C. If installing new, adjustable-length pitch links (nominal length setting):

1. Assemble male rod end, with jam nut and palnut installed, into female rod end. Adjust rod ends until a dimension of 2.620 ± 0.010 inches, measured between rod end bearing centers.
2. Attach pitch link female rod end to outboard side of pitch control arm. Torque bolt per Section 1.320. Install palnut, torque per Section 1.320, and torque stripe per Figure 2-1.
3. Connect pitch link male rod end to blade pitch horn. NAS1149F0432P, NAS1149F0463P, A214-3 or A141-14 washers may be under nut for chordwise balance. Torque bolt per Section 1.320. Install palnut, torque per Section 1.320, and torque stripe per Figure 2-1.
4. Torque pitch link jam nut and palnut per Section 1.320 and torque stripe per Figure 2-1. Repeat steps 1 thru 4 for opposite blade.
5. Check tail rotor control rigging per Section 10.140.

8.600 C203 YOKE AND A205 FORK ASSEMBLY**8.610 Bearing Removal**

B115-1 Spherical bearings and C648-2 journal bearings may be removed with a press. Press from inner side of bearings while supporting outboard side of yoke or fork. Use a socket or other suitable pressing tool to apply the force.

8.615 C648-2 Bearing Installation (0.5625/0.5630 inch diameter bearing bores)

1. Clean mating surfaces of A205 fork or C203 yoke where C648 bearing is installed. Deburr any sharp edges that may damage bearings during installation.
2. Coat yoke or fork bearing bores with zinc chromate or epoxy primer. While primer is still wet, press in C648 bearing while supporting backside of fork or yoke.

8.620 B115-1 Bearing Installation

1. Press out old bearings.
2. Clean yoke or fork assembly bearing bores of old adhesive.
3. Measure bearing bores; maximum allowable diameter is 0.6260 inches.
4. Lightly coat B115-1 bearing outer races with B270-10 adhesive and install B115-1 bearings into bearing bores. Wipe off excess adhesive. Do not allow adhesive to enter B115-1 bearing itself.
5. While adhesive is still wet, assemble yoke or fork assembly per Section 8.412. Wait until adhesive has been allowed to cure per manufacturer's instructions prior to checking bearing pivot force.

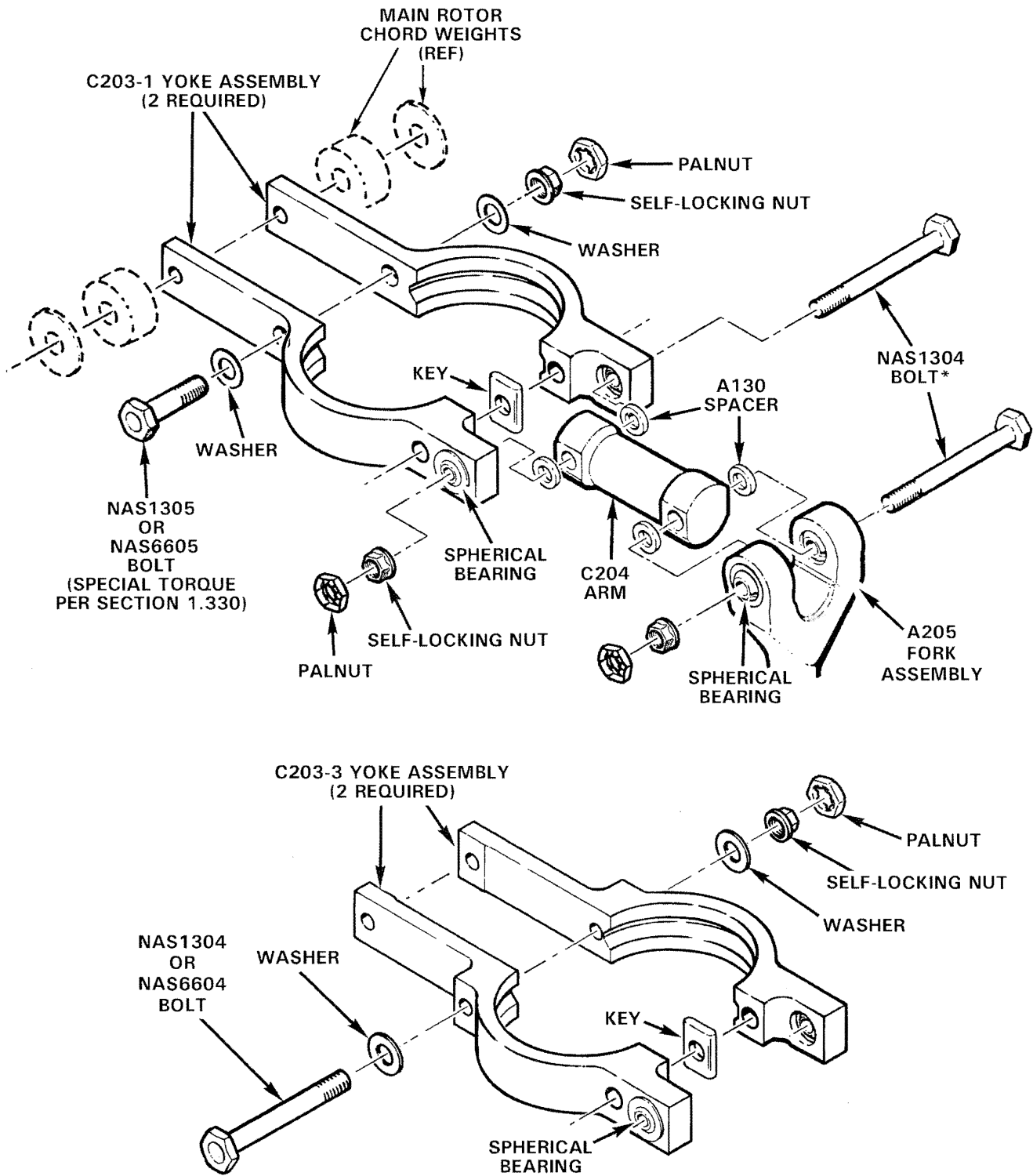

***SMALLER DIAMETER BOLTS THAN LATER REVISION INSTALLATION**

**FIGURE 8-13 R44 EARLY REVISION CHORD ARM YOKE INSTALLATIONS
(DO NOT USE ON FUEL-INJECTED R44 II)**

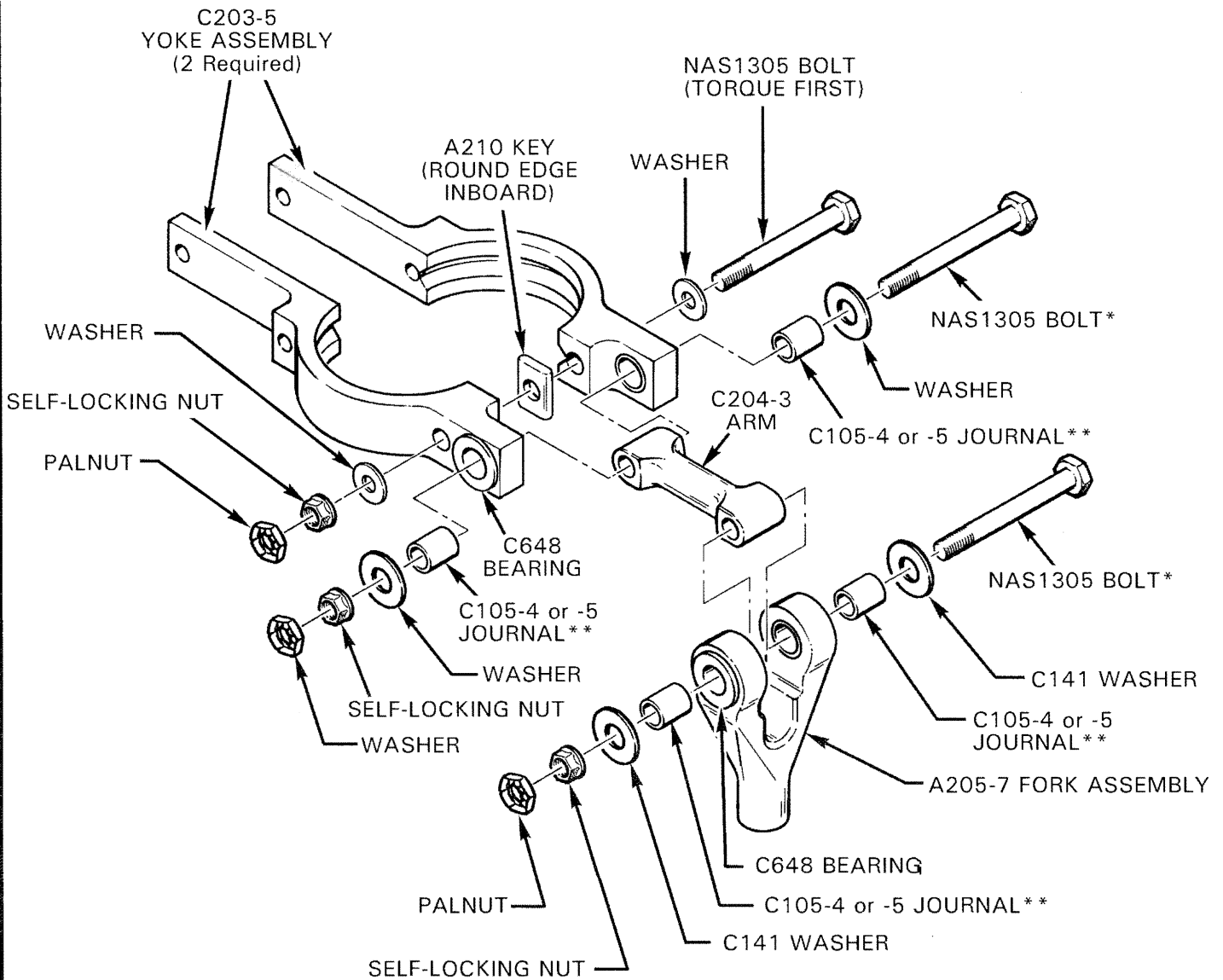

***Note larger diameter bolts than on earlier revision installations.**

****Select a combination of C105-4 or -5 journals to provide 0.001 - 0.010 inch axial play in joint. Refer to Figure 2-9.**

FIGURE 8-13A R44 II & R44 CHORD ARM YOKE INSTALLATIONS

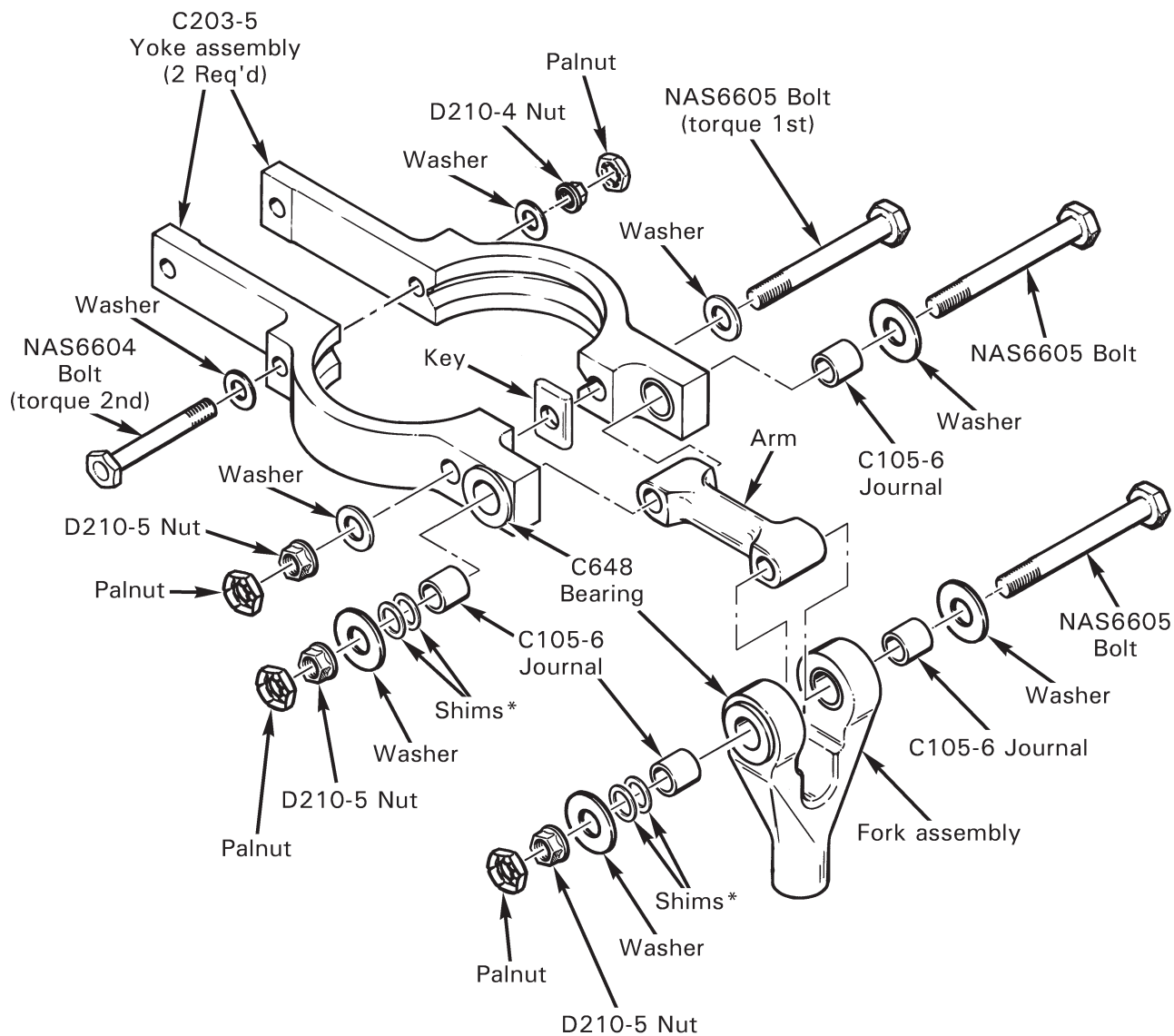

*Select a combination of C117-67, -68, and/or -69 shims to provide 0.001–0.010 inch axial play in joint. Refer to Figure 2-9.

FIGURE 8-13B R44 II & R44 LATE REVISION CHORD ARM YOKE INSTALLATIONS

Intentionally Blank

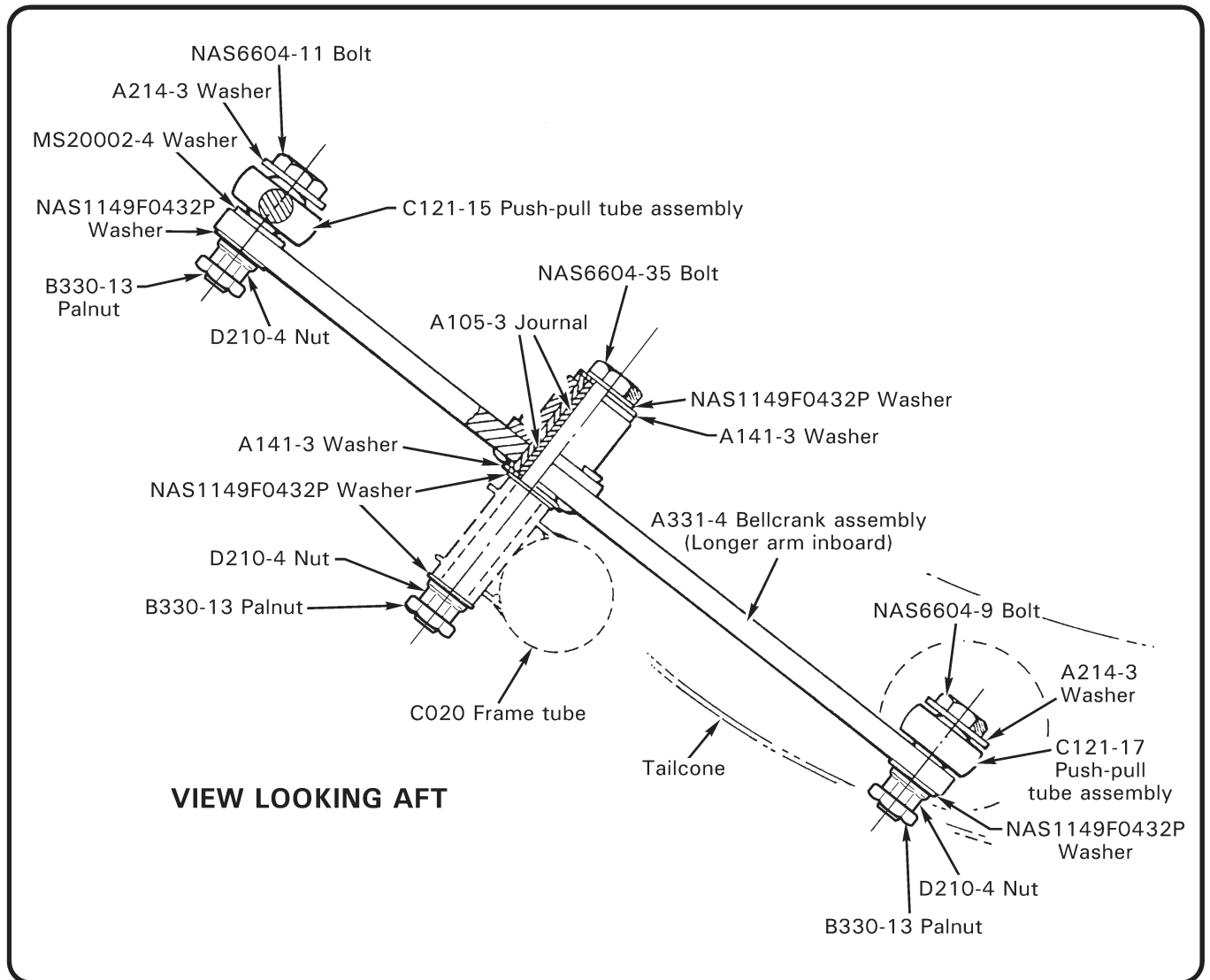



FIGURE 8-14 A331-4 BELLCRANK INSTALLATION

CORRECT ALIGNMENT



INCORRECT ALIGNMENT



MS28773 Retainers
(Diagonal split)

MS28773 Retainers, installed on hydraulic system fittings, are superseded by D454 Retainers. Verify correct alignment of diagonal split if installing new MS28773 Retainers. MS28773 Retainers ARE NOT reusable.



D454 Retainers
(Straight split)

D454 Retainers, installed on hydraulic system fittings, supersede MS28773 Retainers. D454 Retainers have a straight split to eliminate installation error, and are more rigid for better sealing. D454 Retainers ARE reusable.

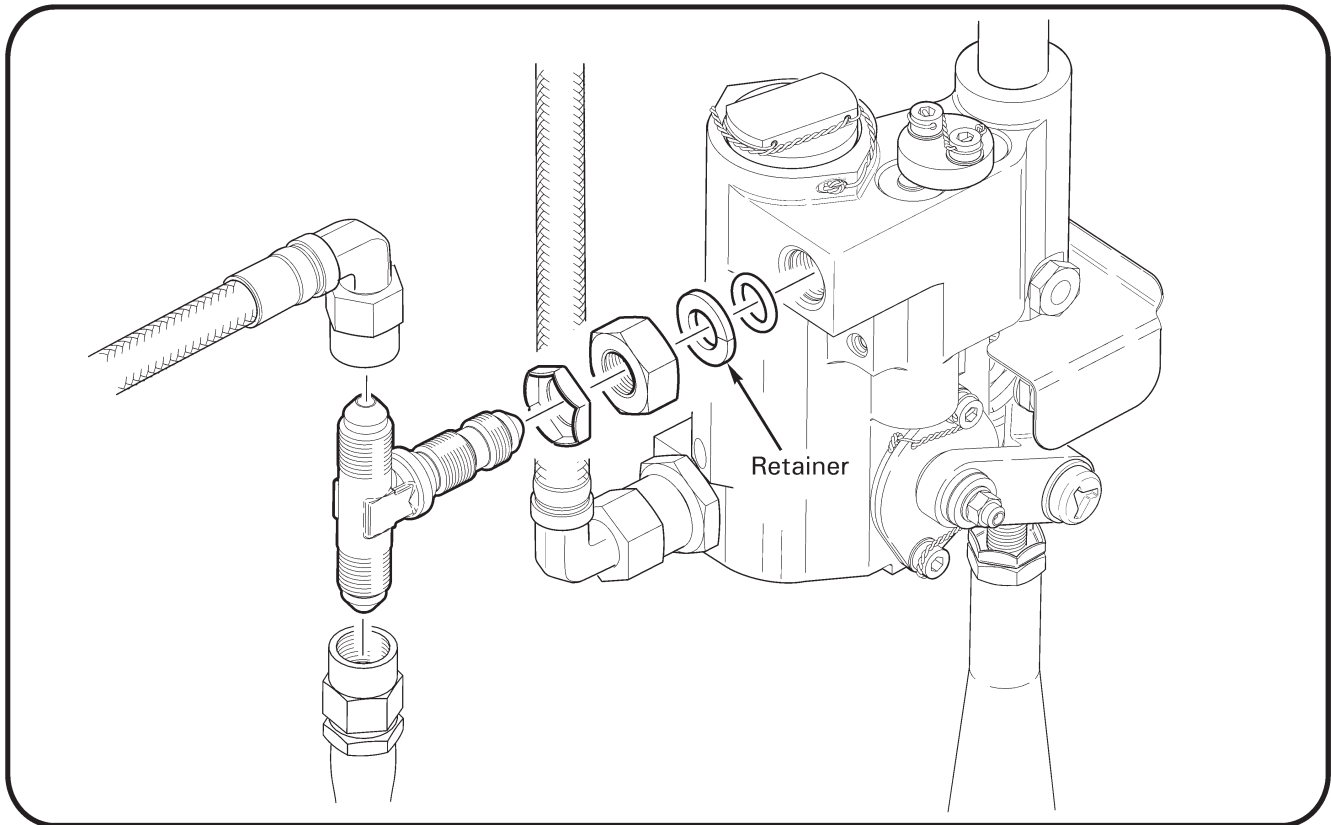

FIGURE 8-16 HYDRAULIC FITTING O-RING RETAINERS

8.700 Hydraulic Flight Controls

8.710 Hydraulic Reservoir Removal

CAUTION

Use LPS PreSolve to clean hydraulic parts. Do not use alcohol.

1. Refer to Figure 8-1A. Remove C706-1 tailcone cowling.
2. Place a one-liter container beneath suction line fitting on reservoir. Disconnect and cap suction line at reservoir aft elbow and allow reservoir fluid to drain into container.
3. Disconnect and cap one return and two pressure lines from reservoir elbows.
4. Disconnect pump bypass solenoid electrical connector.
5. Cut safety wire from and remove four drilled-head bolts securing reservoir to upper frame. Remove reservoir.

8.720 Hydraulic Reservoir Installation

CAUTION

Use LPS PreSolve to clean hydraulic parts. Do not use alcohol.

1. Refer to Figures 8-1A and 8-16. Install elbows into reservoir with palnuts, jam nuts, retainers, and O-rings.
2. Point forward elbows up. Torque jam nuts and palnuts per Section 1.330. Forward elbows are different sizes and nuts require different torques.
3. Position reservoir on upper frame and install four drilled-head bolts. Torque bolts per Section 1.330 and safety wire.
4. Connect servo pressure and return lines to forward elbows and torque per Section 1.330. Torque stripe jam nuts, palnuts, and B-nuts.
5. Connect pump bypass solenoid electrical connector and ty-rap wires as required.
6. Connect pump suction line to aft (suction) elbow. Position elbow to minimize preload on suction line. Torque jam nut, palnut, and B-nut per Section 1.330 and torque stripe.
7. Connect pump pressure line to remaining elbow. Position elbow to minimize preload on pressure line. Torque jam nut, palnut, and B-nut per Section 1.330 and torque stripe.
8. Verify line and servo clearance to surrounding structure while flight controls are moved through full range of travel.
9. Verify reservoir cooling hose is secure and directed at center of reservoir cooling fins. Adjust as required.

8.720 Hydraulic Reservoir Installation (continued)

10. Fill reservoir with A257-15 (see Section 1.470) fluid.

CAUTION

Cleanliness of hydraulic fluid is vital to proper system operation. Use only clean fluid from sealed containers and avoid contamination from dirty funnels, tubing, etc.

11. Secure C706-1 tailcone cowling and connect any attached antenna.
12. Bleed hydraulic system per Section 1.190.

8.730 Hydraulic Pump Removal**CAUTION**

Use LPS PreSolve to clean hydraulic parts. Do not use alcohol.

1. Remove auxiliary fuel tank per Section 12.121.
2. Refer to Figure 8-1A. Remove reservoir filler-vent.
3. Cover reservoir filler-vent hole with finger to prevent fluid loss. Disconnect and cap suction line at hydraulic pump forward T-fitting.
4. Disconnect and cap pressure line at hydraulic pump aft T-fitting.
5. Remove four self-locking nuts and washers securing pump to gearbox.
6. Remove pump, phenolic insulator if installed, and o-ring. Discard o-ring. Do not remove metal cartridge.

8.740 Hydraulic Pump Installation

CAUTION

Use LPS PreSolve to clean hydraulic parts. Do not use alcohol.

1. Refer to Figures 8-1A and 8-16. Install palnuts, jam nuts, retainers, and new o-rings on T-fittings and install T-fittings in pump. Ensure lower arm of both T-fittings is capped.

CAUTION

Verify retainers have been installed per Figure 8-16. Improper installation will result in loss of hydraulic fluid.

2. Lubricate new o-ring with A257-2 gearbox oil and install on pump mounting flange. If C267 cartridge in MRGB has 0.125 inch thick flange then also install phenolic insulator on pump mounting flange. Install pump on gearbox studs so larger T-fitting is forward. Install washers and self-locking nuts on studs and special torque per Section 1.330.
3. Position pump T-fittings so that outlets are approximately 45° from vertical with top pointing inboard. Special torque jam nuts and palnuts per Section 1.330. Nuts are different sizes and require different torques.
4. Connect reservoir pressure hose to pump pressure (aft) T-fitting. Special torque B-nut per Section 1.330.
5. Cover reservoir filler-vent hole with finger to prevent fluid loss. Remove plug from suction hose and connect hose to pump suction (forward) T-fitting. Special torque B-nut per Section 1.330.
6. Install auxiliary fuel tank per Section 12.122 and verify minimum 0.25 inch clearance with hydraulic hoses and fittings. Reposition hoses and fittings as required.
7. Torque stripe jam nuts and B-nuts per Figure 2-1.
8. Bleed hydraulic system per Section 1.190.
9. Install a 110-4 Telatemp on easily visible surface of pump.

8.750 Hydraulic Servo Removal

CAUTION

Do not pressurize hydraulic system while any hydraulic system component is disconnected or removed.

1. Remove mast fairing and C706-1 tailcone fairing assembly. Remove aft belly panel.
2. Refer to Figures 8-1A and 8-1C. Perform the following measurements on all D212-1 hydraulic servo assemblies to be removed:
 - a. Measure & record dimension between D200-1 clevis hole center & top of servo piston shaft.
 - b. Apply cyclic and collective frictions. With collective full down and hydraulics unpressurized, manipulate cyclic stick so piston in servo to be removed is in its lowest position. Measure & record dimension between top of servo piston shaft and top of cylinder assembly.

CAUTION

Dimension between clevis hole center and top of servo piston shaft must be 1.40 ± 0.03 inches; dimension between top of servo piston shaft and top of cylinder assembly must be 0.28 ± 0.03 inch. If dimensions are not within required range, perform main rotor rigging per Section 10.120 after servo installation.

3.
 - a. Forward Right Servo: Remove aux fuel tank per Section 12.121.
 - b. Forward Left Servo: Remove main fuel tank per Section 12.111.
4. Remove hardware securing servo clevis to C121-25 or -31 push-pull tube's lower rod end.
5.
 - a. Forward Servo: Mark (right or left) position of C121-24 or -28 push-pull tube's. Loosen jam nut and palnut securing tube to servo's lower rod end, and remove hardware securing tube's lower rod end to C175-4 cyclic pivot assembly. Count and record number of turns required to unscrew tube from servo's lower rod end.
 - b. Aft Servo: Remove hardware securing C343-8 tube's lower rod end to C339-1 or -10 jackshaft weldment.

CAUTION

Do not remove tri-wing fastener; servo's lower rod end must remain attached to servo.

6. Disconnect D205 hose assemblies from servo unions (or elbows) and tees. Cap and plug fittings.
7.
 - a. Forward Servo: Remove hardware joining D200-2 scissors. Remove hardware securing servo to D201-1 or -5 support and remove servo. Remove associated C121-24 or -28 push-pull tube.
 - b. Aft Servo: Remove hardware securing servo to C345-5 weldment.

8.750 Hydraulic Servo Removal (continued)

8. Aft Servo: Measure & record center-to-center dimension between servo's lower rod end and C343-8 tube's lower rod end. Loosen palnut and nut securing tube to servo's lower rod end and remove tube.

CAUTION

Dimension between C343-8 tube's rod ends must be 3.90 ± 0.03 inches. If dimension is not within required range, perform main rotor rigging per Section 10.120 after servo installation.

9. Remove clevis, scissor, D200-3 washer, elbows, unions, and tee fittings from servo, as applicable.
10. Actuate servo piston shaft by hand and drain as much hydraulic fluid from servo as possible. Plug servo ports.

8.760 Hydraulic Servo Installation

CAUTION

Do not pressurize hydraulic system while any hydraulic system component is disconnected or removed.

CAUTION

Refer to Section 8.750. Dimension between clevis hole center and top of servo piston shaft must be 1.40 ± 0.03 inches; dimension between top of servo piston shaft and top of cylinder assembly must be 0.28 ± 0.03 inch; dimension between C343-8 tube's rod ends must be 3.90 ± 0.03 inches. If dimension(s) recorded during servo removal were not within required range, or if dimension(s) are unknown, adjust to correct dimensions in Section 8.760 steps 1 and 2, proceed with servo installation thru step 11, then perform main rotor rigging per Section 10.120.

1. Refer to Figures 8-1A and 8-1C. Lightly coat D200-1 clevis threads with B270-21 protectant. Assemble clevis, palnut, jam nut, D200-3 washer (forward servo), and D200-2 scissor (forward servo), and install assembly in D212-1 hydraulic servo assembly piston shaft. Point scissor forward and inboard. Adjust dimension between clevis hole center & top of servo piston shaft to dimension recorded during servo removal. Verify slots in scissor and washer engage piston shaft tangs, then tighten jam nut and palnut finger tight.
2. Aft Servo: Lightly coat servo's lower rod end threads with B270-21 protectant and install C343-8 tube. Adjust tube on servo's rod end, and tube's rod end, to the center-to-center dimension (between rod ends) recorded during servo removal, and with rod ends 90° to each other. Tighten jam nuts and palnuts finger tight.

CAUTION

Do not remove tri-wing fastener; servo's lower rod end must remain attached to servo.

8.760 Hydraulic Servo Installation (continued)

3. a. Forward Servo: Position associated C121-24 or -28 push-pull tube in helicopter. Install hardware securing servo to D201-1 or -5 support. Standard torque fasteners per Section 1.320 and torque stripe per Figure 2-1.
b. Aft Servo: Install hardware securing servo to C345-5 weldment. Standard torque fasteners per Section 1.320 and torque stripe per Figure 2-1.
4. Forward Servos: Install hardware joining scissors (scissor overlap direction not critical); special torque nut to 25 in.-lb, special torque palnut to 5-10 in.-lb, and torque stripe per Figure 2-1.
5. Using backup wrench, align clevis minimum amount necessary to be parallel with helicopter's longitudinal axis. Standard torque jam nut and palnut per Section 1.320, and torque stripe per Figure 2-1.
6. Install hardware securing servo clevis to C121-25 or -31 push-pull tube's lower rod end. Standard torque fastener per Section 1.320 and torque stripe per Figure 2-1.
7. a. Forward Servo: Lightly coat servo's lower rod end threads with B270-21 protectant. Counting number of turns recorded during servo removal, install C121-24 or -28 push-pull tube on servo's lower rod end. Install hardware securing tube's lower rod end to C175-4 cyclic pivot assembly, standard torque fastener per Section 1.320, and torque stripe per Figure 2-1. Using backup wrench, standard torque tube's jam nuts and palnuts, and torque stripe per Figure 2-1.
b. Aft Servo: Install hardware securing C343-8 tube's lower rod end to C339-1 or -10 jackshaft weldment. Standard torque fastener per Section 1.320 and torque stripe per Figure 2-1. Using backup wrench, standard torque jam nuts and palnuts, and torque stripe per Figure 2-1.
8. Refer to Figure 2-1A. Verify proper rod end centering on all push-pull tubes attached to servos.

CAUTION

Refer to Figure 8-16. Improper retainer installation can result in loss of hydraulic fluid and vibrations in the flight controls.

9. Remove caps and plugs. Lubricate new packings using A257-15 hydraulic fluid and install packings on servo unions (or elbows) and tees. Install fittings with associated hardware in servo ports and connect D205 hose assemblies to fittings. Align fittings to minimize hose preload and ensure hose clearance with surrounding structure; special torque fittings per Section 1.330 and torque stripe per Figure 2-1. Special torque hose B-nuts per Section 1.330 and torque stripe per Figure 2-1.
10. a. Forward Right Servo: Install aux fuel tank per Section 12.122.
b. Forward Left Servo: Install main fuel tank per Section 12.112.
11. Bleed hydraulic system per Section 1.190.

8.760 Hydraulic Servo Installation (continued)

12. Perform the following measurements on all servos just installed:
 - a. Measure & record dimension between clevis hole center & top of servo piston shaft. Verify dimension is same as recorded during removal; adjust as required.
 - b. Apply cyclic and collective frictions. With collective full down and hydraulics unpressurized, manipulate cyclic stick so piston in servo just installed is in its lowest position. Measure & record dimension between top of servo piston shaft and top of cylinder assembly. Verify dimension between top of piston shaft and top of cylinder is same as recorded during removal. As required, lengthen or shorten associated C121-3, -24, -28, or -30 push-pull tube to obtain correct dimension and repeat this step.

NOTE

Cyclic must be manipulated after each push-pull tube adjustment and prior to measuring in order to accommodate freeplay at unpressurized input.

CAUTION

Dimension between clevis hole center and top of servo piston shaft must be 1.40 ± 0.03 inches; dimension between top of servo piston shaft and top of cylinder assembly must be 0.28 ± 0.03 inch; dimension between C343-8 tube's rod ends must be 3.90 ± 0.03 inches. If dimension(s) recorded are not within required range, adjust to correct dimensions in Part 8.760 steps 1 and 2, proceed with servo installation thru step 11, then perform main rotor rigging per Section 10.120.

13. Install aft belly panel. Install C706-1 tailcone fairing assembly and mast fairing.
14. Perform pitot line leak check per Section 13.211.

Intentionally Blank

CHAPTER 9

ROTOR SYSTEMS

<u>Section</u>	<u>Title</u>	<u>Page</u>
9-00	Description	9.1

Intentionally Blank

CHAPTER 9
ROTOR SYSTEMS

9-00 Description

Main Rotor information has been moved to Chapter 28.

Tail Rotor information has been moved to Chapter 30.

Intentionally Blank

CHAPTER 10

RIGGING, TRACK AND BALANCE

<u>Section</u>	<u>Title</u>	<u>Page</u>
10.000	Rigging, Track and Balance	10.1
10.001	Introduction	10.1
10.002	Rod End Adjustment Procedure	10.1
10.100	Rigging	10.2
10.110	Main Rotor Flight Controls	10.2
10.111	Cyclic Controls	10.2
10.112	Swashplate	10.4
10.113	Collective Control	10.4
10.120	Main Rotor	10.4
10.121	Cyclic Travel Rigging	10.7
10.122	Collective Travel Rigging	10.10
10.130	Tail Rotor Flight Controls	10.11
10.131	Pedals	10.11
10.132	C316 Bellcrank	10.12
10.133	A120-3 Bellcrank	10.12
10.134	Tail Rotor Pitch Links	10.12
10.140	Tail Rotor Rigging	10.12
10.150	Throttle Correlation Rigging	10.19
10.160	Actuator Rigging	10.19
10.200	Track and Balance	10.19
10.210	Equipment Requirements	10.20
10.220	Equipment Installation	10.20
10.221	Main Rotor Equipment Installation	10.20
10.222	Tail Rotor Equipment Installation	10.24
10.230	Main Rotor Track and Balance Procedure	10.29
10.231	Main Rotor Balance Adjustment	10.31
10.232	Main Rotor Pitch Link Adjustment	10.33
10.233	Main Rotor Trim Tab Adjustment	10.39
10.234	Main Rotor Track and Balance Troubleshooting	10.40
10.240	Tail Rotor Balance Procedure	10.42
10.250	Autorotational RPM Adjustment	10.47

Intentionally Blank

CHAPTER 10**RIGGING, TRACK AND BALANCE**10.000 Rigging, Track and Balance10.001 Introduction

This section contains procedures necessary to rig the main rotor flight controls, tail rotor flight controls and throttle correlation. The track and balance procedures in this section are to be used in conjunction with Chadwick-Helmuth balancing equipment instructions.

WARNING

A rotor which is smooth after balancing but then goes out of balance again within a few flights is suspect and must be examined by a RHC-authorized component overhaul facility before further flight.

10.002 Rod End Adjustment Procedures

Refer to § 23-34 Push-Pull Rod End Adjustment.

10.100 Rigging

10.110 Main Rotor Flight Controls

10.111 Cyclic Controls

The cyclic control travel is non-adjustable and is controlled by the A211-3 stop plate attached to cyclic box assembly.

NOTE			
The following push-pull tube assemblies and fork assembly between the keel panels are to be adjusted to the noted center-to-center dimensions:			
C121-1	=	51.03 ± 0.03	inches
C121-3	=	32.54 ± 0.03	inches
C121-19	=	31.38 ± 0.03	inches
A205-3, -5	=	03.80 ± 0.03	inches

- a. Refer to Figure 10-1. Place cyclic control in neutral position. Cyclic neutral position is 7.0 inches to the right of full-left travel and at mid-point of total fore and aft travel or use MT559-1 rigging blocks. Place collective control full down.
- b. Apply full cyclic and collective friction.

NOTE	
Care must be taken not to move cyclic control from neutral position.	

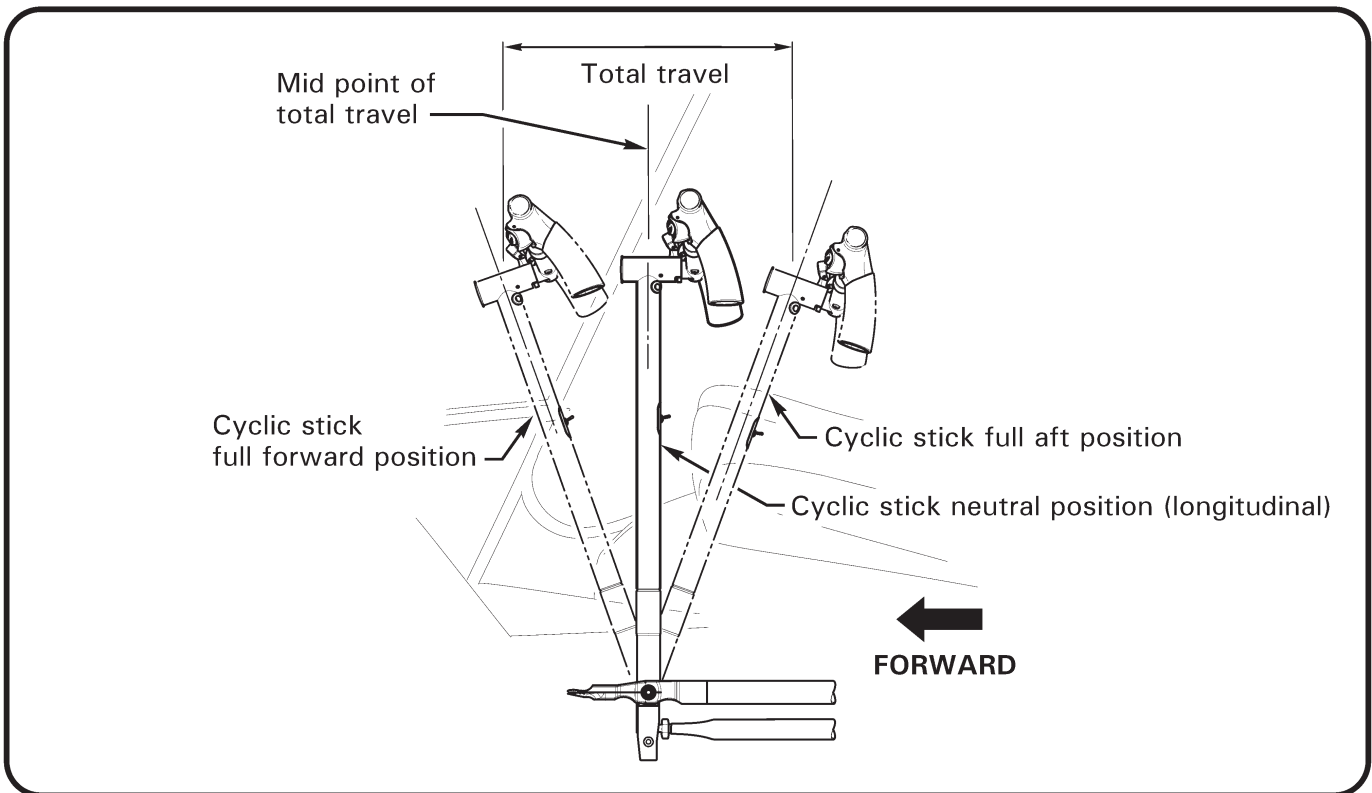
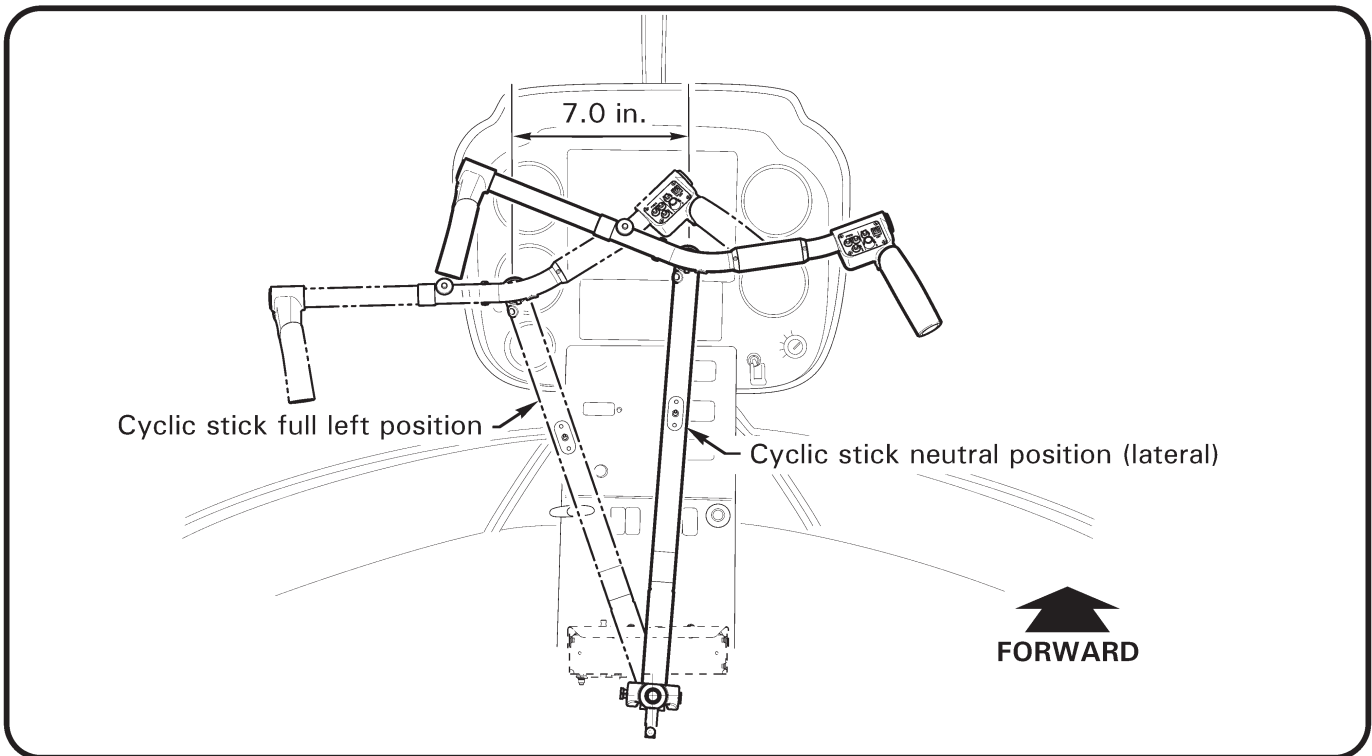

FIGURE 10-1 CYCLIC STICK NEUTRAL POSITION

10.112 Swashplate

1. With cyclic and collective controls locked in position per § 10.111, adjust C121-31 (or C121-25) push-pull tubes to obtain a constant clearance from flange of C281-1 fitting per Figure 10-2. A pair of swashplate rigging blocks may be used as a spacer to set the required clearance.
2. Pressurize hydraulics per § 1.190 steps 1 thru 3 and re-check clearance as required, adjust push-pull tubes to meet required clearance.

10.113 Collective Control

Since the collective slider stop is non-adjustable, this check is to ensure full control travel is obtained and does not interfere with the swashplate travel.

1. Lift the swashplate boot so the ball and slider tube may be observed.
2. With hydraulics pressurized per § 1.190 steps 1 thru 3, raise collective control full up. Swashplate ball must be flush with top of slider tube within 0.03 inch. If ball is not flush with top of tube, lengthen or shorten C121-31 (or C121-25) push pull tubes equally as required to raise or lower swashplate & ball.

10.120 Main Rotor

The main rotor is rigged by determining the average blade angle. Blade angle measurements are taken at the 0.75 radius of the main rotor (or 49.5 inches in from the blade tip).

The main rotor blade angles are measured using the MT525-1 rigging fixture and a Kell-Strom KS113 propeller protractor or a comparable protractor (see Figure 10-4). Use the following procedure to set up for rigging:

1. Initially, adjust both pitch links to 7.54 inches length between rod end centers.
2. Verify that the A205-7 forks at the swashplate are set to the proper length (see Figure 10-3). Measuring to bolt center lines, the lower fork assembly should be 3.70 ± 0.03 inches and the upper fork assembly should be 3.85 ± 0.03 inches.
3. Level the rotorcraft per § 1.220 (Method 2, Main Rotor Hub).
4. Place a tracking stick at the end of one rotor blade and mark the height of the blade tip. Rotate the rotor 180° and mark the height of the opposite blade tip. Teeter the main rotor as necessary to obtain a main rotor track of ± 1 inch.
5. Zero the propeller protractor to the main rotor hub at the location marked "Level Here". The protractor must be placed parallel to the teeter hinge bolt.
6. Pressurize hydraulics per § 1.190 steps 1 thru 3.

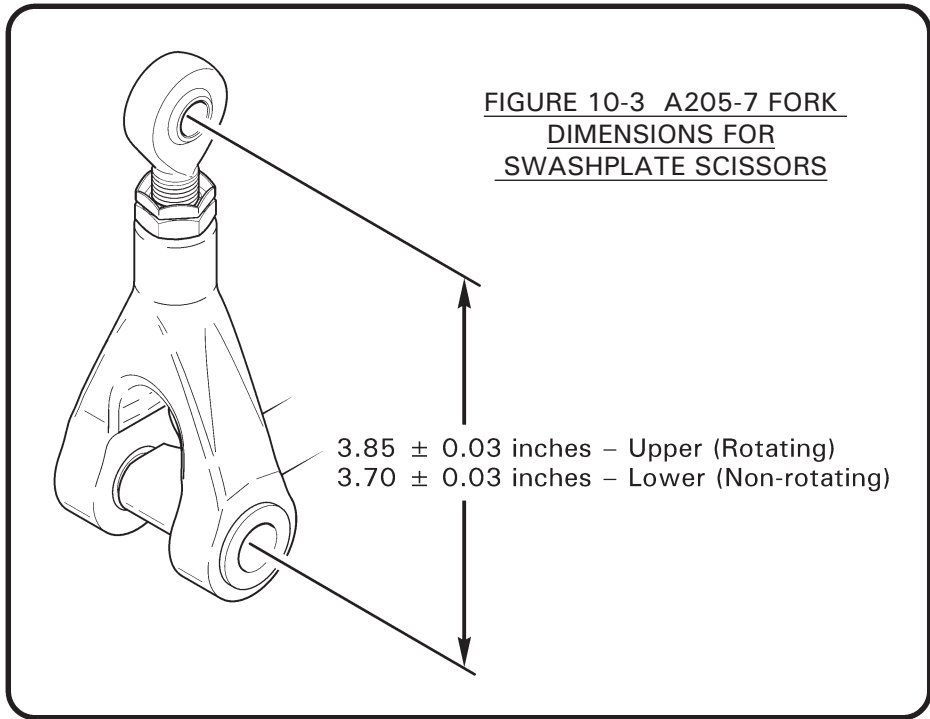
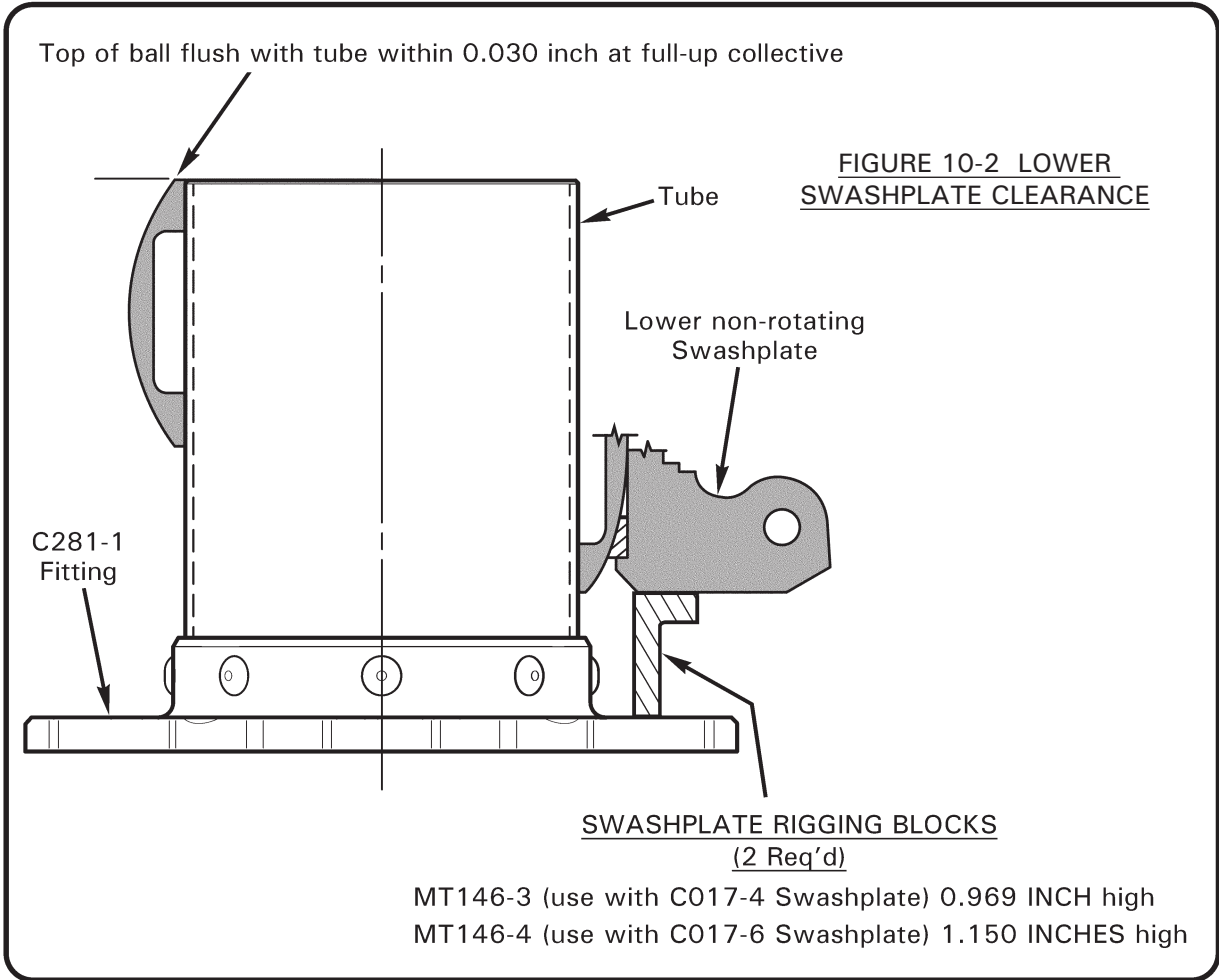

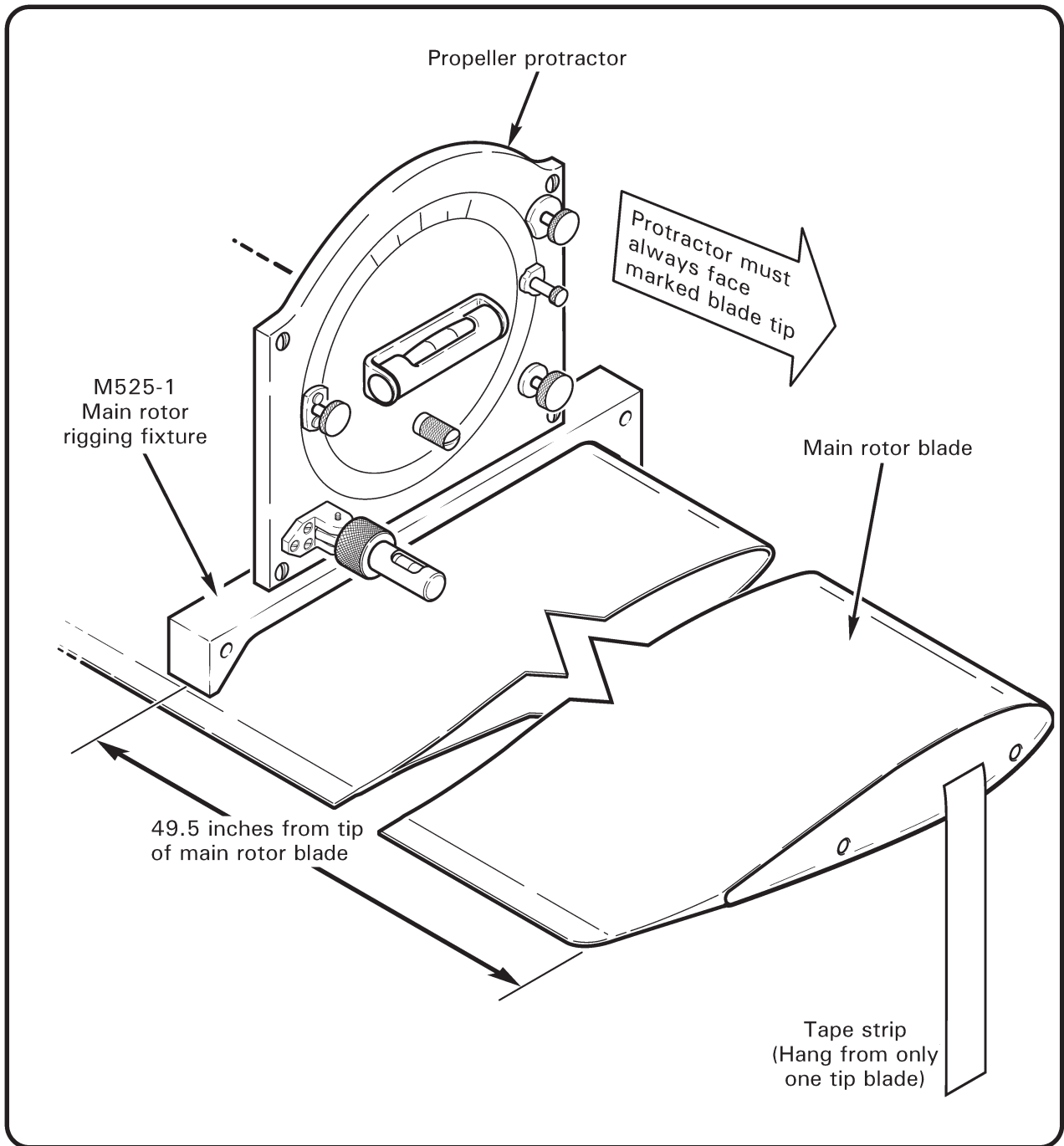

FIGURE 10-4 PLACEMENT OF PROTRACTOR

10.120 Main Rotor (cont'd)

NOTE

When zeroing the protractor, the face or dial should remain facing one of the rotor blades. Mark this blade with a piece of tape. When making blade angle readings, the face or dial of the protractor must always face the marked blade.

- e) Measure in from the tip of each main rotor blade 49.5 inches and place a piece of 1-inch masking tape chordwise across each blade with the center of the tape over the mark.

WARNING

Do not mark the rotor blades with a ball point pen or other sharp instrument. Use a grease pencil or soft marker. Sharp instruments can scratch the blades skins, causing cracks and fatigue failure of the blade.

- f) Mark each rotor blade with a different color designation such as red or blue. This will be used in recording blade angles.

10.121 Cyclic Travel Rigging

NOTE

Adjust collective travel rigging before cyclic travel rigging. Hydraulic flight controls must be pressurized prior to measuring blade angles.

- a) Place the collective control full down. Place the cyclic control in the neutral position laterally (7.0 inches to the right of full left travel) and hold against the forward stop.

NOTE

Sand bags may be used to secure cyclic stick against stops to ensure it will not move.

- b) Rotate the blades so the pitch links are aligned with the longitudinal axis of the helicopter. Place the tracking stick at one of the blade tips for reference when rotating the rotor.

10.121 Cyclic Travel Rigging (cont'd)

c) Forward longitudinal cyclic:

- 1) Measure the blade angles and record below. Rotate the rotor 180° and record the blade angles below.

<u>Blue Blade Position</u>		<u>Cyclic Full Forward</u>
Pitch horn aft		_____° nose up
Pitch horn forward	+	_____° nose down
		_____° ÷ 2 = _____°
		(14.25/13.50 degrees required)

<u>Red Blade Position</u>		<u>Cyclic Full Forward</u>
Pitch horn aft		_____° nose up
Pitch horn forward	+	_____° nose down
		_____° ÷ 2 = _____°
		(14.25/13.50 degrees required)

- 2) Adjust the aft swashplate push-pull tube as required (one full turn = 0.44°) to obtain blade angle averages between 13.50° and 14.25°. Additional coarse adjustment is available by simultaneously adjusting the two forward push-pull tubes but they both must be adjusted exactly the same amount.

d) Aft longitudinal cyclic:

- 1) Place the cyclic control in the neutral position laterally and hold against the aft stop.
- 2) Measure the blade angles and record below. Rotate the rotor 180° and record the blade angles below.

<u>Blue Blade Position</u>		<u>Cyclic Full Aft</u>
Pitch horn aft		_____° nose down
Pitch horn forward	+	_____° nose up
		_____° ÷ 2 = _____°
		(14.25/13.50 degrees required)

<u>Red Blade Position</u>		<u>Cyclic Full Aft</u>
Pitch horn aft		_____° nose down
Pitch horn forward	+	_____° nose up
		_____° ÷ 2 = _____°
		(14.25/13.50 degrees required)

10.121 Cyclic Travel Rigging (cont'd)

- 3) Adjust the aft swashplate push-pull tube as required (one full turn = 0.44°) to obtain blade angle averages between 13.50° and 14.25°. Additional coarse adjustment is available by simultaneously adjusting the two forward push-pull tubes, but they both must be adjusted exactly the same amount.

NOTE

If adjustment is required to obtain aft cyclic control blade angles, the forward cyclic must be rechecked.

e) Left Lateral Cyclic:

- 1) Place the cyclic control in the neutral position longitudinally (mid travel) and hold the cyclic against the left stop.
- 2) Rotate the rotor until the pitch links are aligned with the lateral axis of the helicopter. Place the tracking stick at the end of one blade for reference.
- 3) Measure the blade angles and record below. Rotate the rotor 180° and record the blade angles below:

<u>Blue Blade Position</u>	<u>Cyclic Full Left</u>	
Pitch horn right	_____	nose up
Pitch horn left	+ _____	nose down
	= _____	÷ 2 = _____ ° Average (8.5/7.5 degrees required)

<u>Red Blade Position</u>	<u>Cyclic Full Left</u>	
Pitch horn right	_____	nose up
Pitch horn left	+ _____	nose down
	= _____	÷ 2 = _____ ° Average (8.5/7.5 degrees required)

- 4) Adjust either of the two forward push-pull tubes as required (one full turn = 0.6 degree) to obtain blade angle averages between 7.5° and 8.5°.

f) Right lateral cyclic:

- 1) Place the cyclic control in the neutral position longitudinally (mid travel) and hold the cyclic against the right stop.

10.121 Cyclic Travel Rigging (cont'd)

- 2) Measure the blade angles and record below. Rotate the rotor 180° and record the blade angles below:

<u>Blue Blade Position</u>	<u>Cyclic Full Right</u>	
Pitch horn right	_____	nose down
Pitch horn left	+ _____	nose up
	= _____	÷ 2 = _____ ° Average
		(7.0/6.0 degrees required)

<u>Red Blade Position</u>	<u>Cyclic Full Right</u>	
Pitch horn right	_____	nose down
Pitch horn left	+ _____	nose up
	= _____	÷ 2 = _____ ° Average
		(7.0/6.0 degrees required)

- 3) Adjust either of the two forward push-pull tubes as required (one full turn = 0.6 degree) to obtain blade angle averages between 6.0° and 7.0°.

NOTE

If adjustment is required to obtain right cyclic control blade angles, the left cyclic must be rechecked.

10.122 Collective Travel Rigging

- a) Place the cyclic control in the neutral position (see Figure 10-1). Place the collective control full down. Apply full cyclic and collective friction.
- b) Rotate the main rotor to align pitch links with the longitudinal axis of the helicopter. Place the tracking stick at the end of one blade for reference.
- c) Measure the blade angles using the MT525-1 rigging fixture and propeller protractor.

10.122 Collective Travel Rigging (cont'd)

NOTE

The MT525-1 fixture is placed on top of the blade at 49.5 inches from blade tip. The fixture must be held tightly against the leading edge to ensure accurate readings. All measurements must be taken with protractor facing marked blade.

Record blade angles, then rotate rotor 180° and again record angles. Adjust the pitch link of each blade until the two blade angles are within 0.2 degrees of each other when the blade pitch horn is in the forward position. Check the blade angles with each blade pitch horn aft. Average of these angles must be within 0.2 degrees also.

COLLECTIVE FULL DOWN

	<u>Blue Blade</u>	<u>Red Blade</u>
Pitch horn forward	_____ ° nose up	_____ ° nose up
Pitch horn aft	+ _____ ° nose up	+ _____ ° nose up
	_____ ° ÷ 2 = _____ °	_____ ° ÷ 2 = _____ °

(1.0/2.0 degrees required)

- d) Raise collective control to the full up position. Apply full collective friction. Measure the blade angles per Step c) above and record averages below.

	<u>Blue Blade</u>	<u>Red Blade</u>
Pitch horn forward	_____ ° nose up	_____ ° nose up
Pitch horn aft	+ _____ ° nose up	+ _____ ° nose up
	_____ ° ÷ 2 = _____ °	_____ ° ÷ 2 = _____ °

(Average 12.5°/13.5° degrees above collective-down required for rigging; autorotation rpm adjustment will determine final angle)

- e) Track and balance main rotor per Section 10.200.

10.130 Tail Rotor Flight Controls

10.131 Pedals (See Figure 10-5)

Pedal rigging is accomplished as follows:

- a) Insert a 3/16-inch diameter rigging pin through the hole in the right-hand keel panel and the rigging pin holes in the C317-1 bellcrank.
- b) Adjust the C121-9 push-pull tubes as required to obtain a dimension of 2.90 ± 0.03 inches from the pedal to the right hand stop located on the side of the forward console (does not apply to helicopters without stop on lower console).

10.132 C316 Bellcrank (See Figure 10-5)

Remove rigging pin and place left pedal against its stop. Adjust C343-1 push-pull tube to obtain 0.10 - 0.20 inches between C316-1 rod end and bulkhead (0.3 - 0.5 for helicopters without pedal stop on lower console).

10.133 A120-3 Bellcrank

With left pedal at stop, adjust the C121-17 push-pull tube length as required to obtain 0.35 ± 0.03 inch between two faces of pitch control assembly and the housing. (See Figure 10-7).

10.134 Tail Rotor Pitch Links

Adjust the pitch links to a dimension of 2.620 ± 0.010 inches between rod end centers (see Section 8.570).

10.140 Tail Rotor Rigging

- 1) Set up:
 - a) Level the rotorcraft per Section 1.220 (Method 2, Main Rotor Hub).
 - b) Rotate the tail rotor until the blades are parallel to the tailcone.
 - c) Tape a tracking stick to the tailcone at the tip of the fwd blade.

NOTE

A tracking stick can be made using a 1" x 12" strip of aluminum with a 90° bend 2 inches from one end.

- d) Visually align the tail rotor to a zero teeter position and mark the tracking stick where the tip of the tail rotor blade passes.
- e) Rotate the tail rotor 180°, using the forward flex coupling so teeter angle is not disturbed, until the opposite blade tip is aligned with tracking stick. Mark the stick.
- f) Teeter the tail rotor to position the blade tip to the mid point between the marks. Rotate the tail rotor and check that the blades track. Repeat the above procedure as necessary to track the tail rotor.
- g) Place the left pedal against its stop. Mark the tracking stick where the blade tip passes the stick. Place the right pedal against its stop and mark the tracking stick.

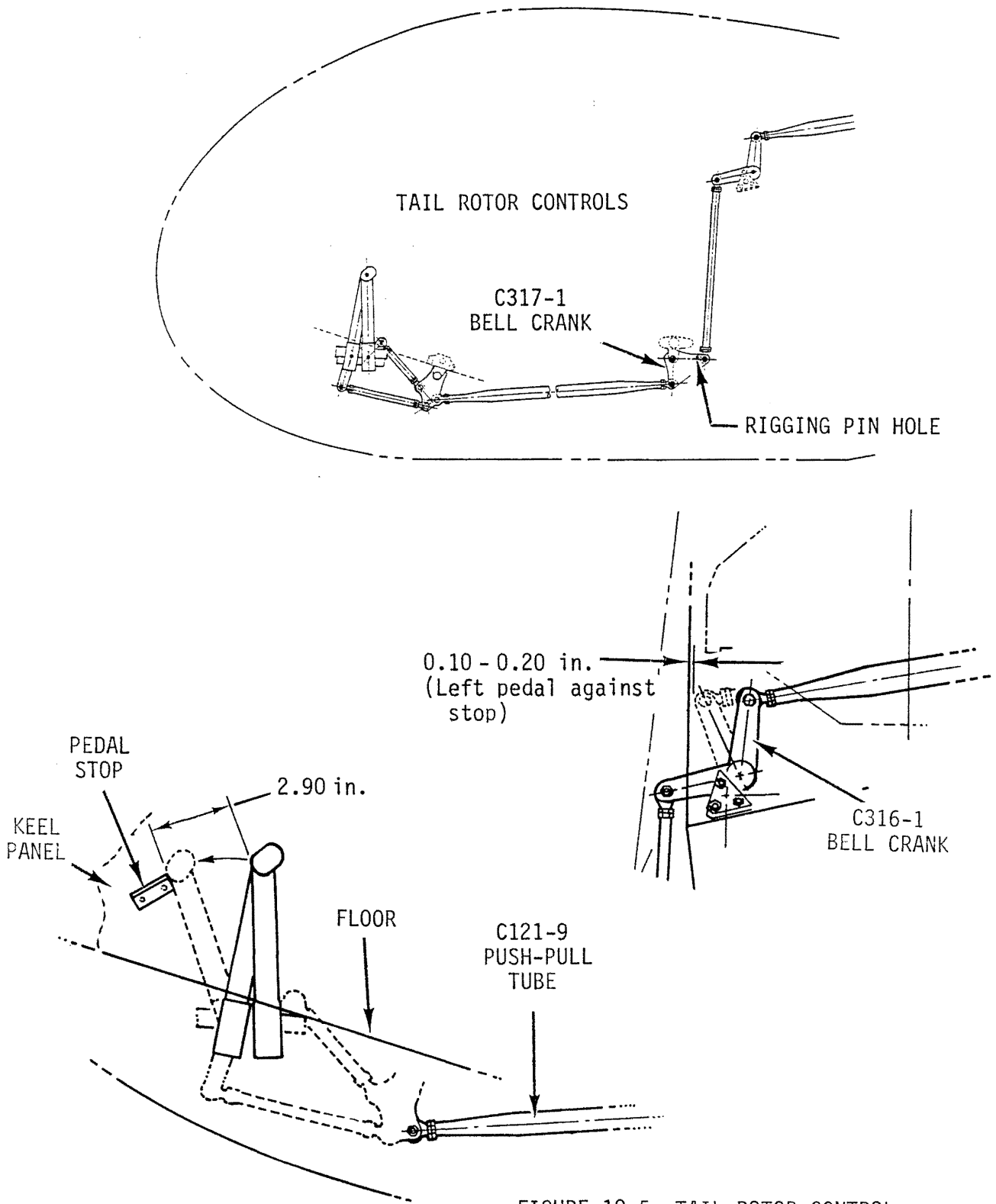

FIGURE 10-5 TAIL ROTOR CONTROL PEDAL RIGGING

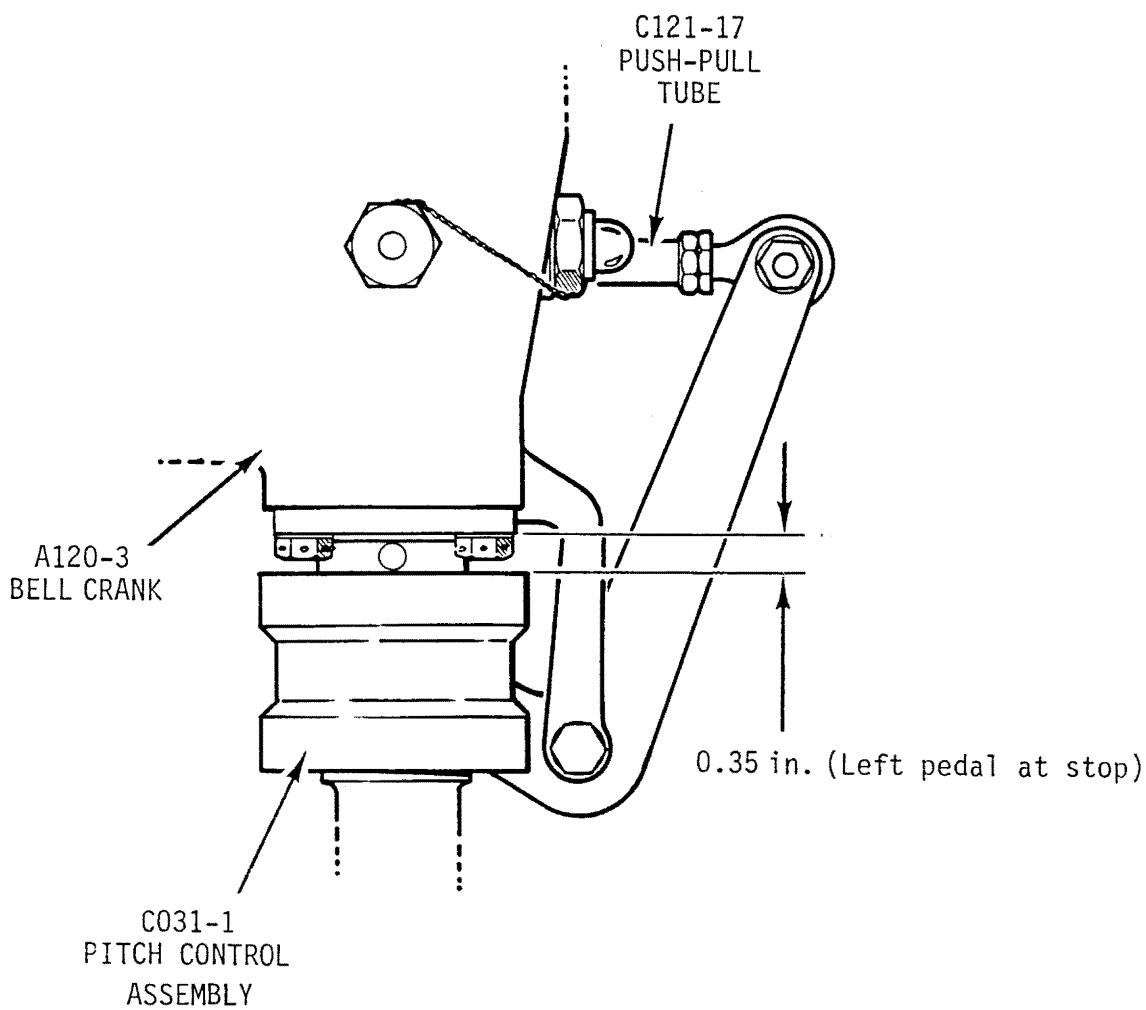

FIGURE 10-6 A120-3 BELL CRANK RIGGING

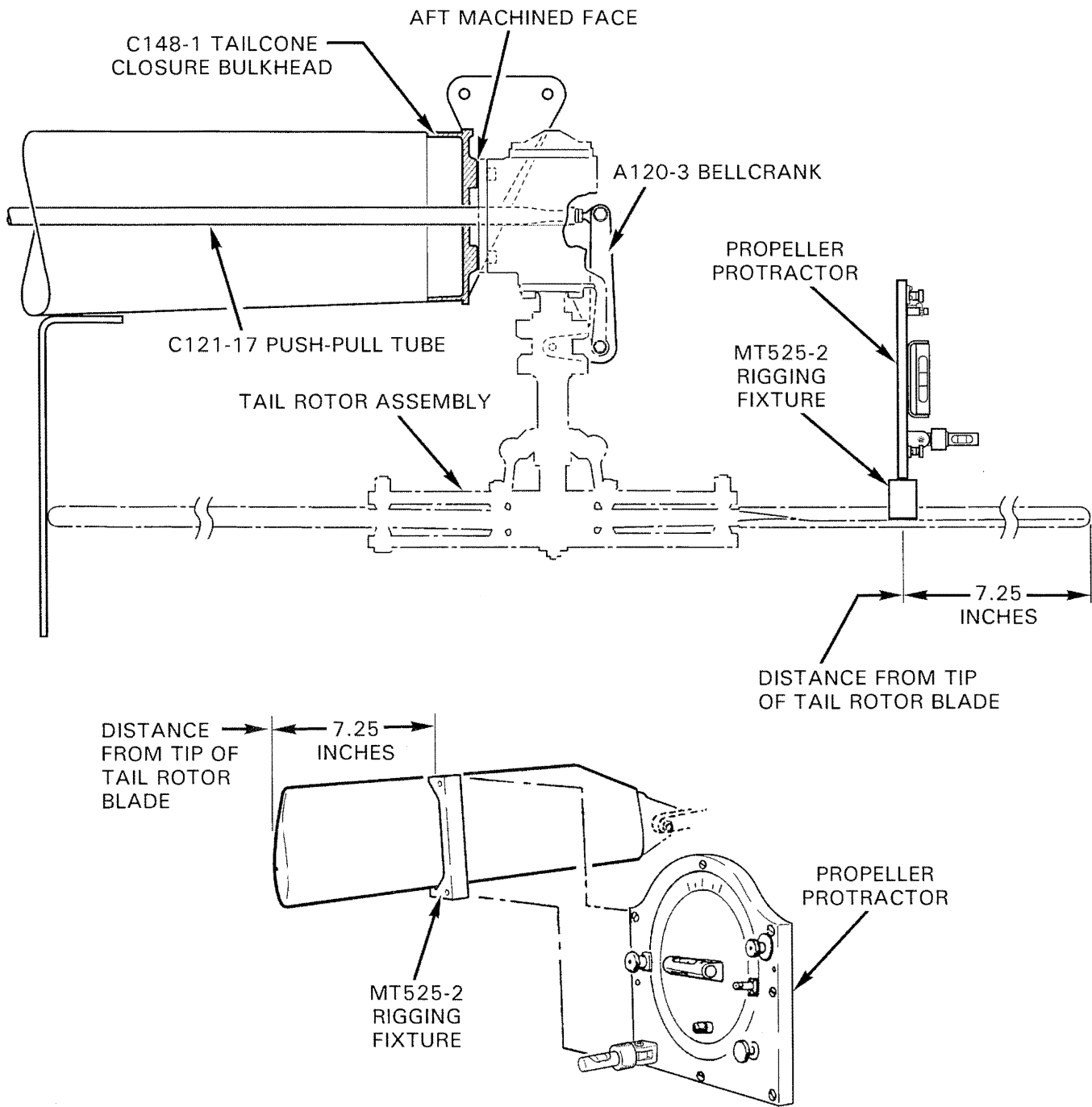

FIGURE 10-7 TAIL ROTOR RIGGING

10.140 Tail Rotor Rigging (cont'd)

2) Measure the tail rotor blade angles as follows:

- a) Using a soft marker or grease pencil mark each blade as red or blue.
- b) Measure in from each blade tip 7.25 inches and place 3/4 inch masking tape chordwise on each blade at this point.
- c) Have someone hold one blade tip at left pedal track mark with left pedal against its stop.
- d) Place MT525-2 rigging fixture on aft blade inboard side.

NOTE

MT525-2 fixture must straddle masking tape.

- e) Using a propeller protractor measure blade angle and record below. Rotate tail rotor 180 degrees and record opposite blade angle.

Pedals Full Left

Blue Blade _____ ° nose right

Red Blade + _____ ° nose right

_____ ° ÷ 2 = _____
(18.5/19.0 degrees required)

CAUTION

For acceptable track, differences between Blue and Red blade angles must not exceed 0.4 degree. If blade angles cannot be adjusted to within 0.4 degree of each other using adjustable pitch links then remove tail rotor assembly and rotate it one-half revolution, reinstall and repeat above procedure. If blade angles still cannot be adjusted to within 0.4 degree of each other then replace blade(s). Contact factory for blade matching assistance.

NOTE

Adjustable pitch link jam nuts must be tight to ensure accurate blade angle measurements.

10.140 Tail Rotor Rigging (cont'd)

WARNING

Both pitch links must be same part number (same type and material). Mixing one-piece with adjustable-length pitch links is prohibited. Mixing steel one-piece with aluminum one-piece pitch links is prohibited.

- f. Adjustment of blade angles is made using rod ends of C121-17 push-pull tube. One full turn of rod end will change blade angles 0.33 degrees. Adjust rod end as necessary to obtain 18.5 to 19.0 degrees.
- g. Place right pedal against its stop. Measure blade angles and record below using right pedal track mark.

Pedals Full Right

Blue Blade _____ ° nose left

Red Blade + _____ ° nose left

_____ ° ÷ 2 = _____

(15.5/16.5 degrees required)

- h. Adjust C121-17 push-pull tube as necessary to obtain blade angles of 15.5 to 16.5 degrees.

NOTE

If adjustment is required to obtain right pedal blade angles, left pedal angles must be rechecked.

- i. If blade angle range, for left and right pedal settings, cannot be obtained using above procedure, this indicates pedal travel is either too great or too small. Use following procedure to check and adjust pedal travel:
 - 1) Add right and left pedal angles together. If total is less than 34.0° pedal total travel is too small. If total is greater than 35.5° total travel is too great.
 - 2) If total travel is too small, first increase right pedal travel by increasing length of C121-9 push-pull tube. To increase left pedal travel, decrease length of C343-3 push-pull tube.

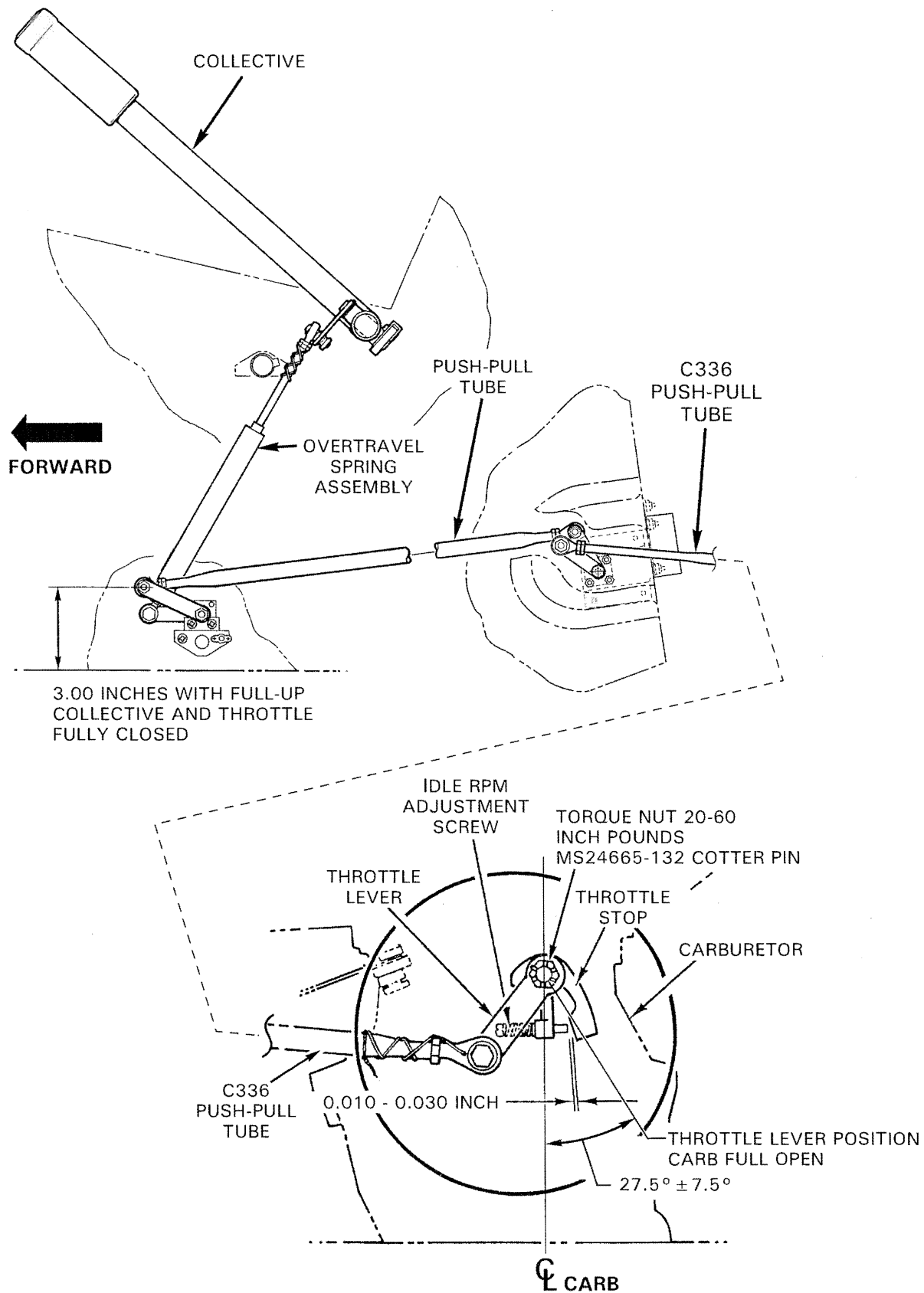

FIGURE 10-8 THROTTLE CORRELATION RIGGING (CARBURETED SHIPS)

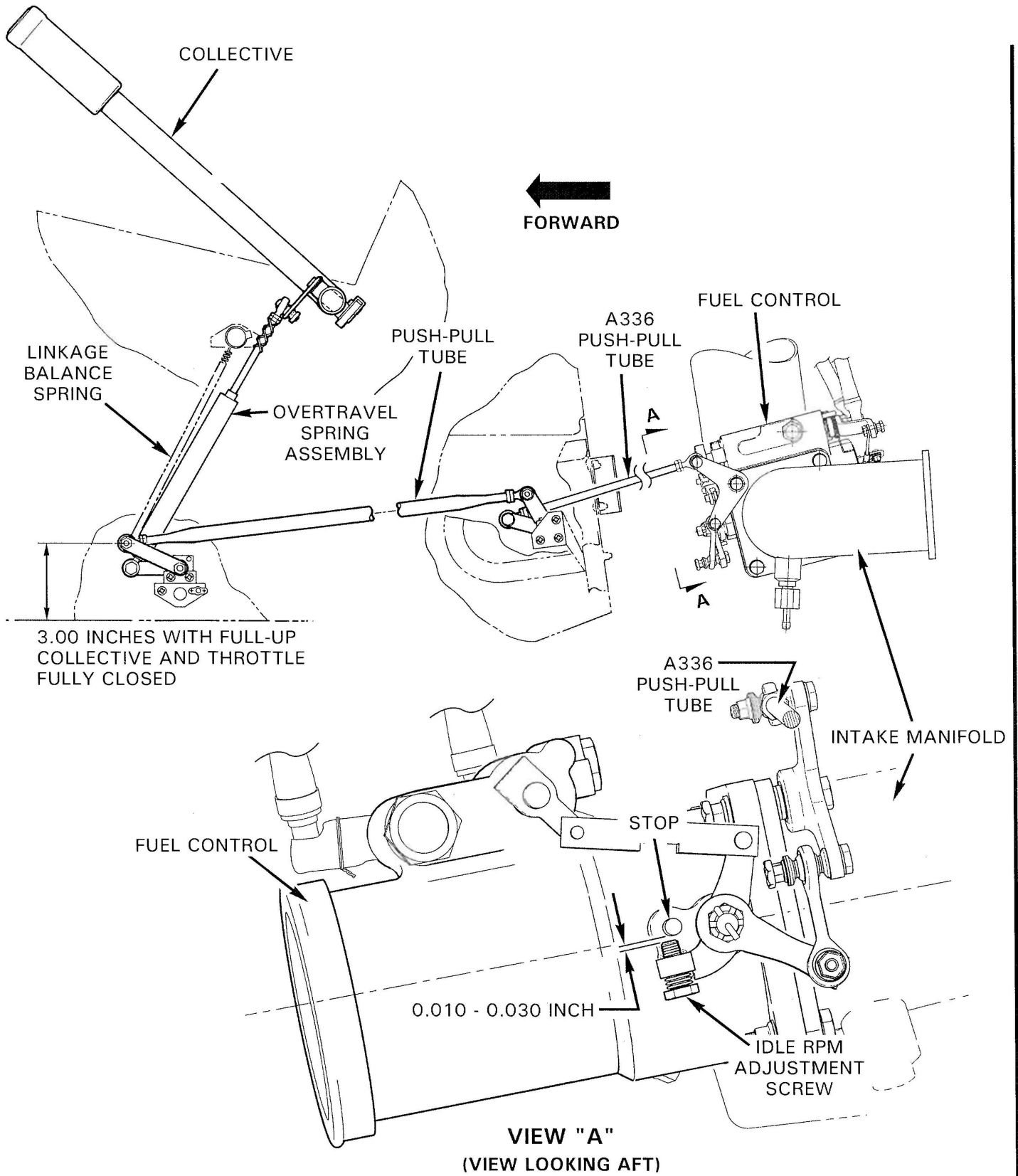

FIGURE 10-8A THROTTLE CORRELATION RIGGING (FUEL INJECTED SHIPS)

Intentionally blank

10.140 Tail Rotor Rigging (cont'd)

- 3) To decrease the total travel, shorten the C121-9 push-pull tube for right pedal travel and increase the length of C343-3 or C343-9 push-pull tube for left pedal travel.
- 4) Recheck the tail rotor blade angles per steps e) through h) above.
- j) Ensure all rod ends are installed properly by checking the push-pull tube witness holes. Tighten all rod end palnuts and jam nuts. Torque stripe all nuts.
- k) Balance tail rotor per Section 10.240.

10.150 Throttle Correlation Rigging (see Figure 10-8)

For in-service check and adjustment:

1. Verify idle rpm is correct with engine warm, clutch fully engaged, and throttle closed. Adjust O-540 idle to 53-57% and IO-540 idle to 58-62%.
2. Shut down helicopter.
3. Rotate twist-grip throttle fully closed through overtravel spring pressure to positive stop. Holding throttle tight against stop, raise collective full up while observing throttle arm on carburetor or fuel control, as applicable. Throttle arm should move 0.010-0.030 inch off of idle stop screw when collective up-stop is reached.
4. If necessary, adjust length of throttle push-pull tube at carburetor or fuel control, as applicable.
5. Standard torque jam nut(s) per Section 1.320, check witness holes, and torque stripe per Figure 2-1.

10.160 Actuator Rigging

No field adjustment of actuator-engaged belt tension is permitted. Adjust actuator's down-limit stop screw so there is a delay of less than 5 seconds before rotor starts turning when actuator is engaged at start up.

10.200 TRACK AND BALANCE

The Chadwick-Helmuth Vibrex system, the TEC ACES system, the Dynamic Solutions Systems' MicroVib system, or equivalent equipment is required to perform dynamic rotor balancing and in-flight tracking checks.

10.210 Equipment Requirements

The following list of equipment may be used on the R44 for track and balance:

- a) Balancers

Chadwick-Helmuth	177M05
Model Number	177M-6
	177M-6A
	177M-7
	177M-7A
	8350 series
	M192 series
	or equivalent equipment

- b) Strobex

Chadwick-Helmuth	135M-10*
Model Number	135M-10A*, B* and C*
	135M-11
	or equivalent equipment

* When tracking the main rotor using the 135M-10 series Strobex a double interrupter must be used.

- c) Cables, accelerometers/velocimeters, pickups, and targets**

Chadwick-Helmuth	3140	D.C. Adapter Cable
Model Number	3030	Magnetic pickup
	3319-1 or 10808-25	Magnetic pickup cable
	4177	Accelerometer
	4296-1 and -2	Accelerometer Cable
	3300	Target Patches
	4270	Target Patches
	7310	Velocimeter
	11210-20/-50	Velocimeter Cable

- d) Brackets**

Robinson MT121-1	Magnetic Pickup Bracket
------------------	-------------------------

- e) Charts**

Robinson	Main Rotor Chart
	Tail Rotor Chart

** As required by the balancing equipment being used.

10.220 Equipment Installation

10.221 Main Rotor Equipment Installation (see Figure 10-9A)

Refer to specific manufacturer's installation instructions when using balancing equipment other than Chadwick-Helmuth. Install Chadwick-Helmuth equipment as follows:

- a) Install the accelerometer/velocimeter under the upper console left-side attachment screw with cable connector pointing outboard.

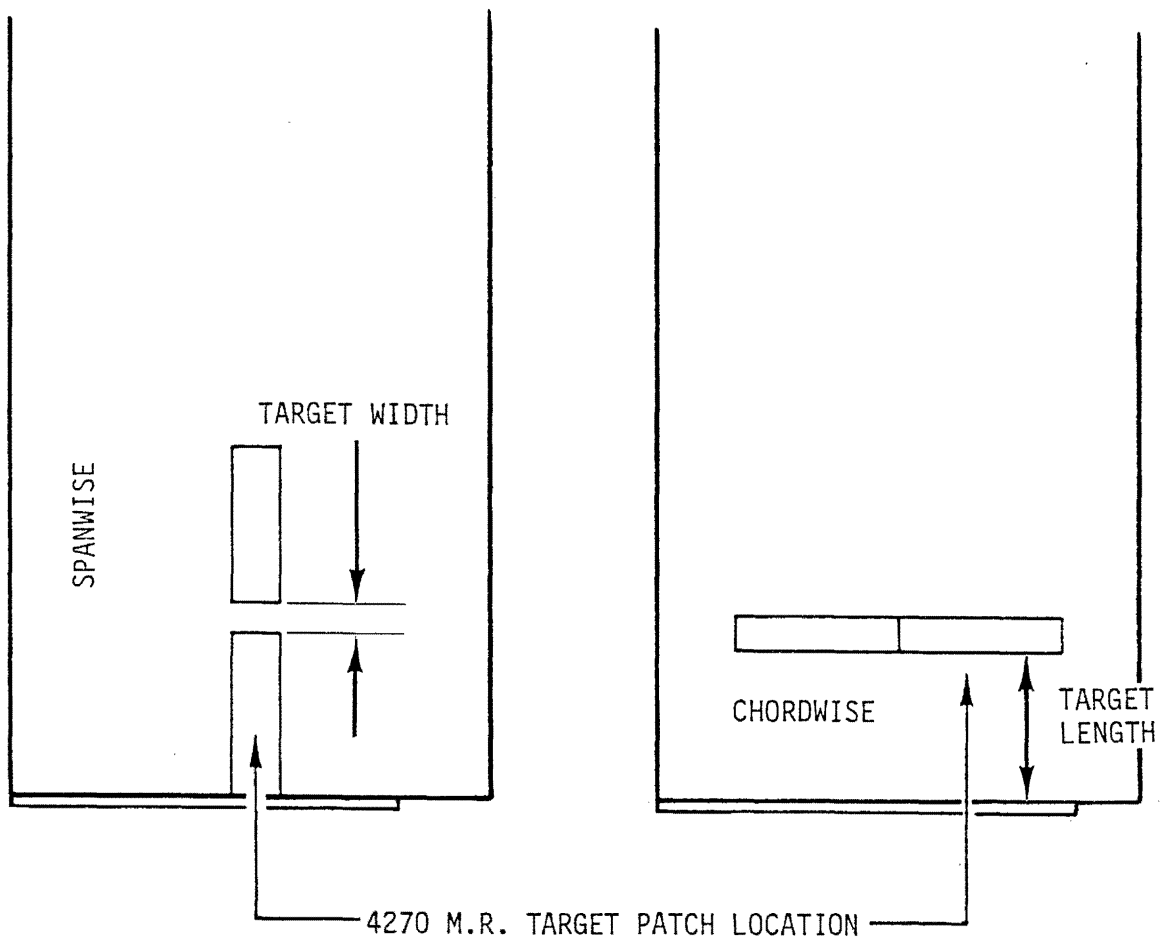

FIGURE 10-9 MAIN ROTOR TARGET PATCH LOCATION

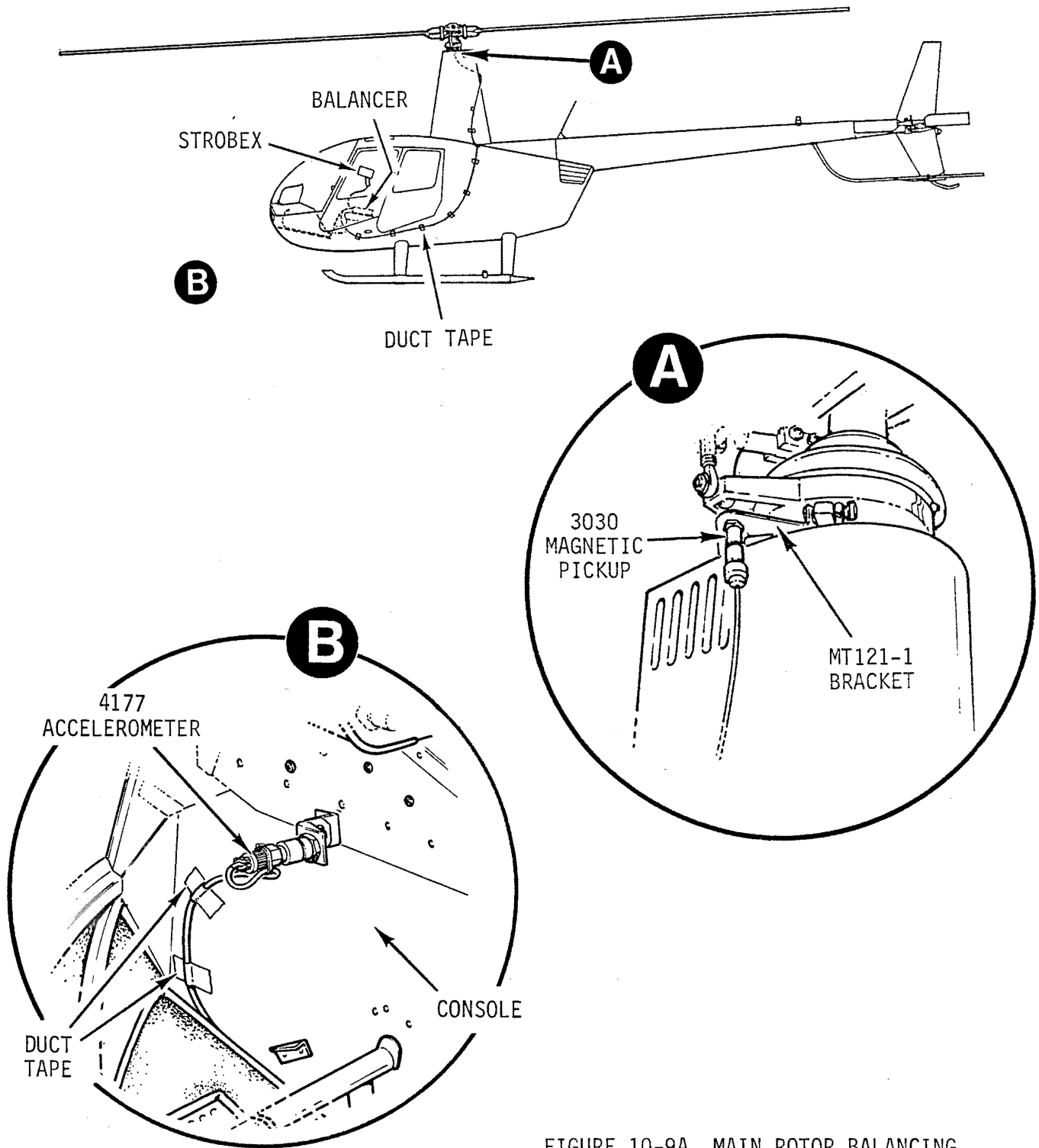

FIGURE 10-9A MAIN ROTOR BALANCING EQUIPMENT INSTALLATION

10.221 Main Rotor Equipment Installation (cont'd)

- b) Install MT121-1 Bracket onto the lower right-hand side of the swashplate. |

WARNING

Ensure attachment bolts are torqued to 200 in.-lb plus nut drag. The MT121-1 Bracket will remain installed for in-flight track and balance. |

- c) Install the 3030 magnetic pickup onto the MT121-1 Bracket. Set the interrupter pickup gap to 0.030" ± 0.010". |
- d) Attach the cable to the magnetic pickup. Pull collective stick full up and cyclic stick full left. Secure the cable to the mast fairing with duct tape. Route the cable to the lower front of the left door frame. Secure the cable every 12 inches with duct tape. |

CAUTION

Security of the cable is essential as the helicopter will be flown at Vne.

- e) Attach the cable to the accelerometer/velocimeter mounted on the left forward hold down screw of the console. Secure with duct tape.

CAUTION

Ensure the cable cannot become entangled with tail rotor pedals.

- f) Attach the cables to the balancer and secure excess cable to the bracket in front of the left seat.
- g) Apply the 4270 target tapes to the main rotor blades per Figure 10-9.

10.222 Tail Rotor Equipment Installation (see Figures 10-9C and 10-9D)

NOTE

Prior to installing balancing equipment, verify blades are clean and smooth, no debris under tip covers (square tip blades), rod end and spherical bearing play are within limits, and elastomeric bearings (if applicable) are satisfactory.

1. Install accelerometer/velocimeter bracket under upper forward tail rotor gearbox output seal housing attachment bolt. Connector end of accelerometer/velocimeter must point up.
2. If using a Vibrex 2000-series balancer with photocell, install photocell bracket between velocimeter and velocimeter bracket as shown in Figure 10-9C.
3. If using Strobex to obtain clock angle, install a target tape spanwise facing outboard on one arm of tail rotor hub. If using photocell to obtain clock angle, install a target tape spanwise facing inboard on one arm of tail rotor hub.
4. Connect cable(s) to accelerometer/velocimeter and photocell (if used). Route cable(s) forward and wrap around tailcone several times. Secure with duct tape.

WARNING

Ensure cable(s) cannot entangle tail rotor.

5. If using Strobex to obtain clock angle, route cable to a position located approximately 20 feet to left of tail rotor. Place sandbags (or similar) on cable to prevent cable movement. If using photocell to obtain clock angle, cables may be routed into cabin and secured with duct tape to prevent cable movement.
6. Connect cable(s) to balancer.

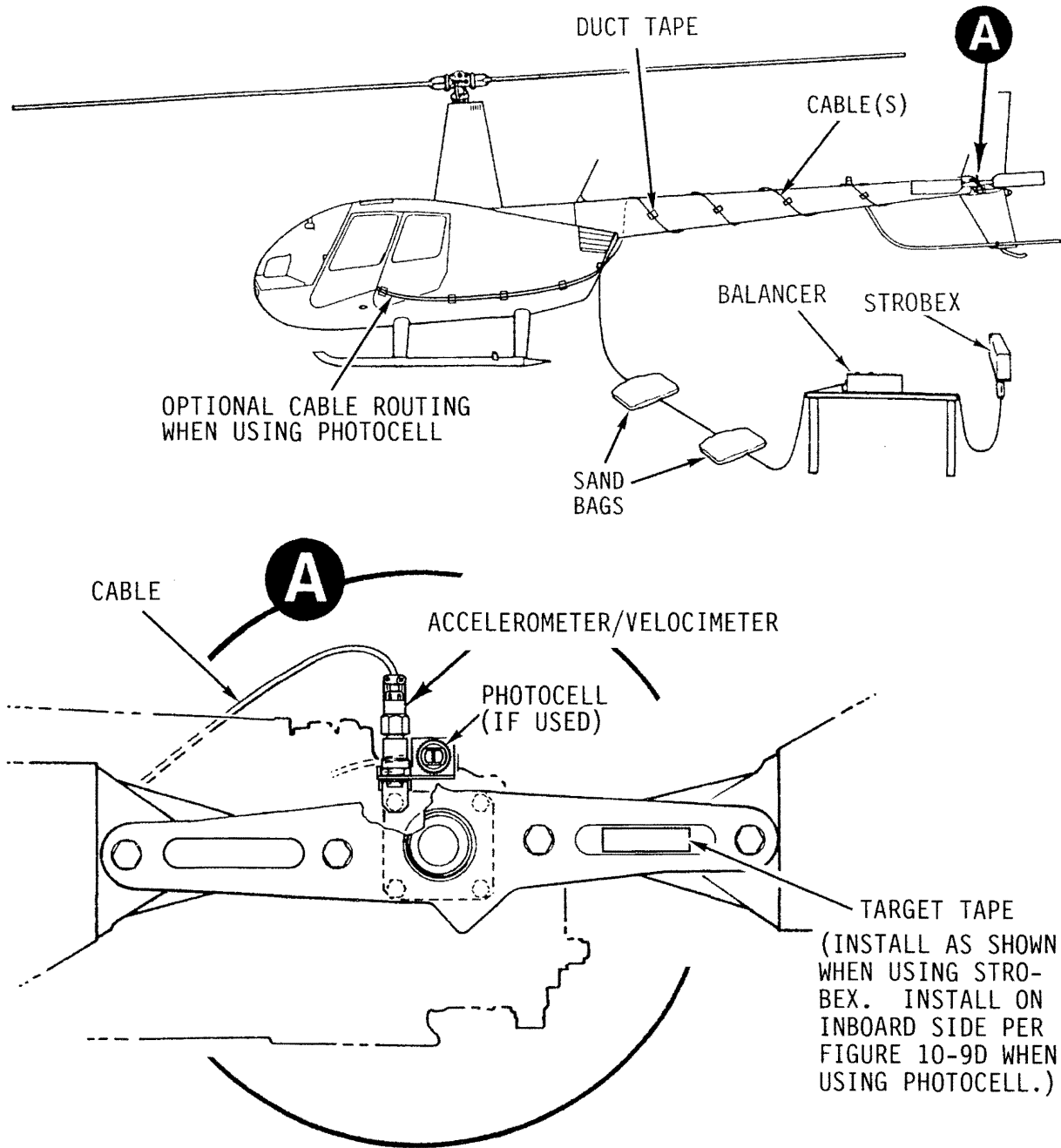
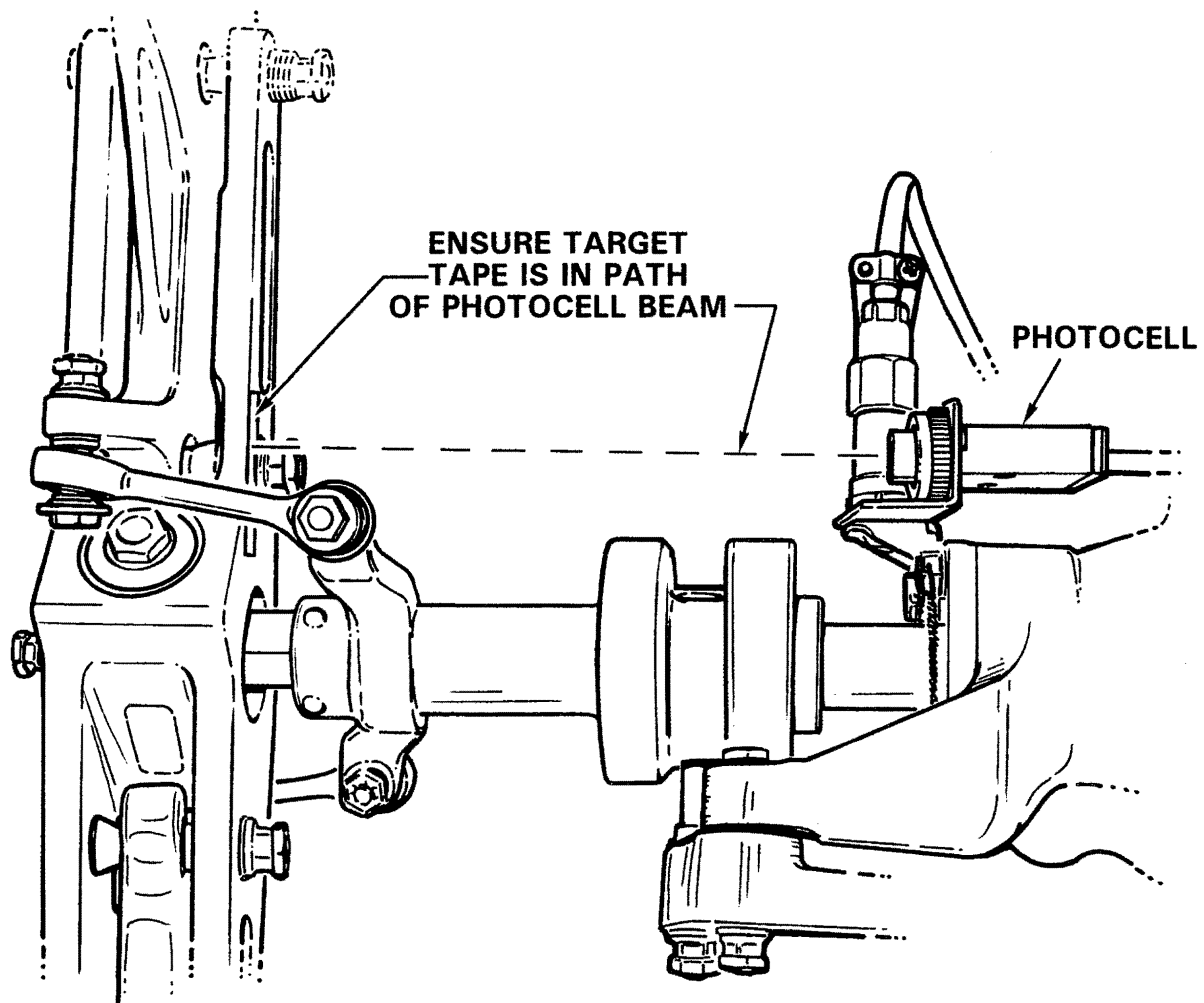

FIGURE 10-9C
TAIL ROTOR BALANCING EQUIPMENT INSTALLATION



(VIEW LOOKING FORWARD)

FIGURE 10-9D

TAIL ROTOR PHOTOCELL INSTALLATION

Intentionally Blank

DATE _____ SERIAL NO. _____

PAGE _____

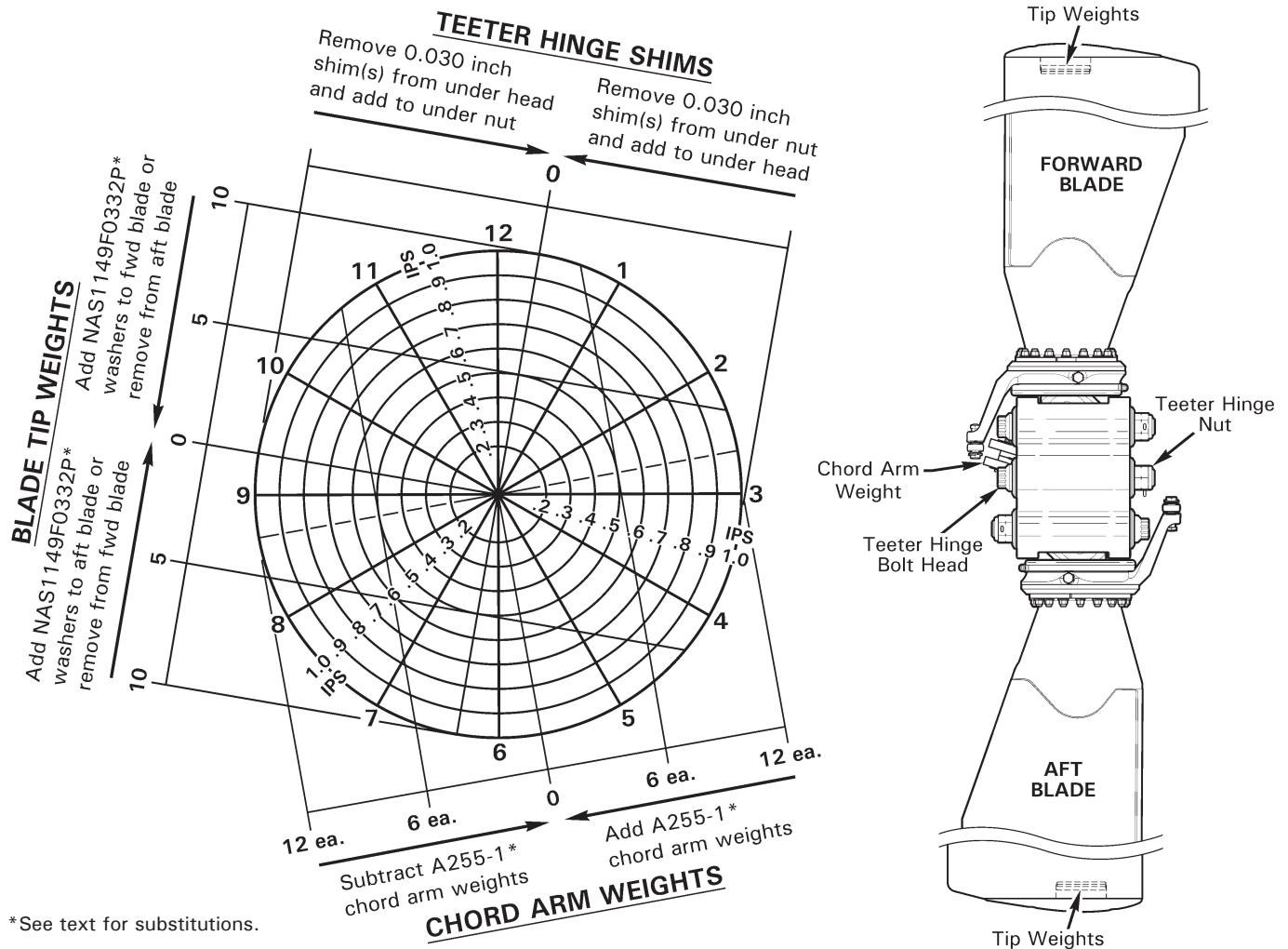

*See text for substitutions.

BALANCE		TRACK (KNOTS)										
CLOCK	IPS	HOVER	CLIMB	50	60	70	80	90	100	110	120	130

Adjustment: _____

CLOCK	IPS	HOVER	CLIMB	50	60	70	80	90	100	110	120	130

Adjustment: _____

CLOCK	IPS	HOVER	CLIMB	50	60	70	80	90	100	110	120	130

Adjustment: _____

CLOCK	IPS	HOVER	CLIMB	50	60	70	80	90	100	110	120	130

FIGURE 10-10 MAIN ROTOR TRACK AND BALANCE CHART

10.230 Main Rotor Track and Balance Procedure

NOTE

Prior to installing balancing equipment, verify blades are clean and smooth, rod ends & spherical bearings & scissors play are within limits, correct upper (rotating) scissors friction, correct swashplate tilting friction, and coning hinge frictions. Verify interrupter is opposite chord arm.

In-flight track and balance is accomplished using the following testing and adjustment sequence:

1. Check main rotor track in a hover and record data. Adjust track by shortening high blade pitch link per § 10.232 to bring track within 0.25 inch.
2. Check main rotor balance in a hover and record data. Adjust balance as indicated by main rotor balance chart to within 0.2 IPS (inches per second).
3. Fly helicopter at 50, 60, 70, 80, 90, 100, 110, 120, and 130 knots. Check track at each airspeed and record.

WARNING

Do not exceed V_{NE} of helicopter when checking in-flight track.

4. Make slight tab adjustment to correct for a climbing blade by bending trim tab down per § 10.233.
5. Repeat steps 3 & 4 as required until track is within 3/8 inch at all airspeeds.
6. Readjust main rotor balance in a hover to no greater than 0.2 IPS.
7. Check autorotational RPM per § 10.250. Adjust as required.
8. Check main rotor balance in a hover. Verify no greater than 0.2 IPS. Adjust as required.

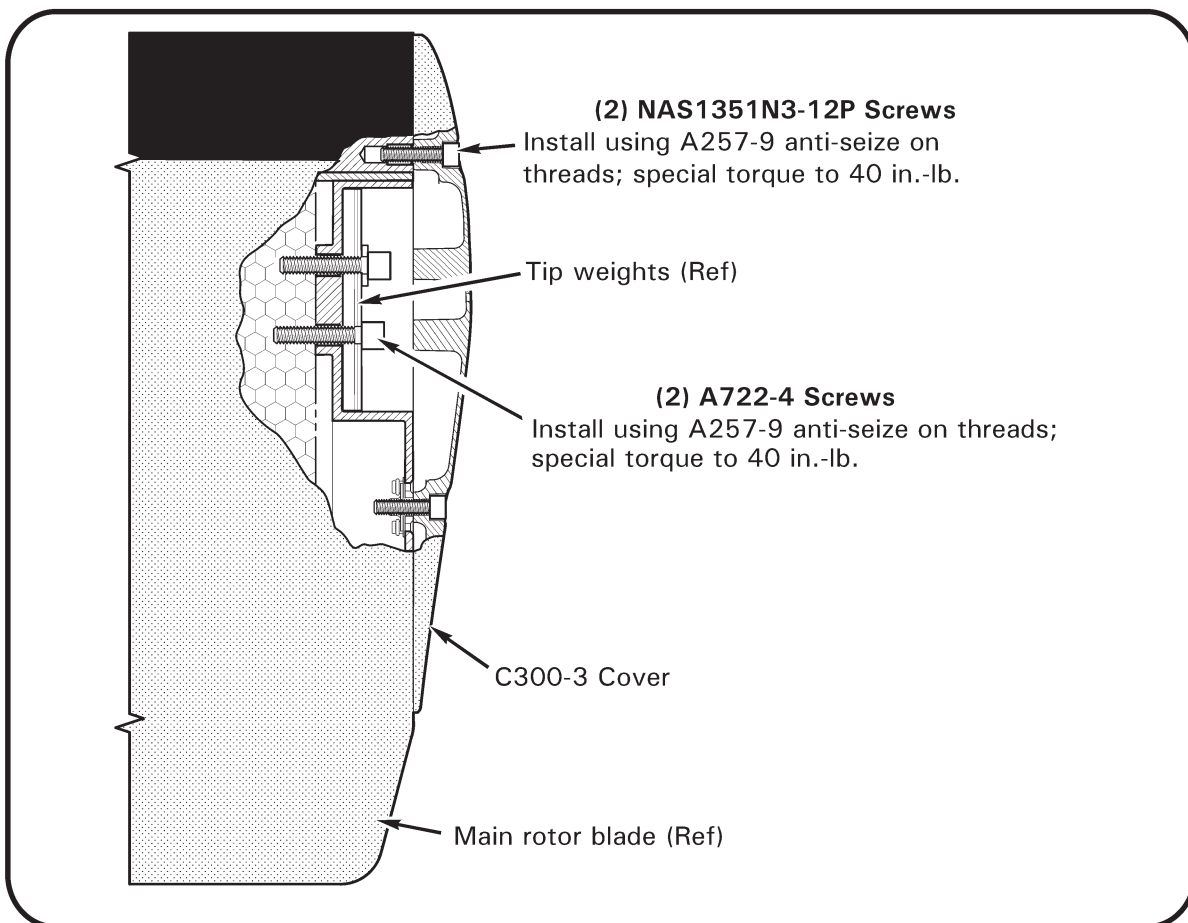

FIGURE 10-11 MAIN ROTOR BLADE TIP

10.231 Main Rotor Balance Adjustment

WARNING

A rotor which is smooth after balancing but goes out of balance within a few flights is suspect and must be examined by RHC before further flight.

A. Tip Weights (Spanwise Balance Adjustment)

1. Remove screws securing tip cover to blade. Balance rotor assembly spanwise by adjusting tip weights as required per Figure 10-10. Washers may be trimmed. Refer to Figure 10-11. Apply light coat A257-9 anti-seize to threads and install screws securing tip weights to blade; special torque screws to 40 in.-lb. Apply light coat A257-9 anti-seize to threads and install screws securing tip cover to blade; special torque screws to 40 in.-lb.

- | | | |
|--------------------------------------|---|--|
| (1) AN960-10 or NAS1149F0363P Washer | = | (2) AN960-10L or NAS1149F0332P Washers |
| (1) C298-2 Weight | = | (5) AN960-10 or NAS1149F0363P Washers |
| (1) C298-3 Weight | = | (11) AN960-10 or NAS1149F0363P Washers |
| (1) C298-4 Weight | = | (4) C298-3 Weights |

B. Teeter Hinge Bolt Shims (Chordwise Balance Adjustment - Coarse Adjustment)

1. Remove and discard teeter hinge nut cotter pin. Remove nut, thrust washer, and any shims.
2. Have two people cone the main rotor blades. Push out teeter hinge bolt (and any shims) with another bolt.
3. Balance rotor assembly chordwise by moving (or exchanging) existing teeter hinge shims to other side of bolt (under head or under nut) as required per Figure 10-10. Install teeter hinge bolt per § 28-10.

C. Chord Arm Weight (Chordwise Balance Adjustment - Fine Adjustment)

1. Balance rotor assembly chordwise by adjusting chord arm weights or washers per Figure 10-10. Total weight not to exceed four A255-2 weights (or equivalent).

- | | | |
|-------------------|---|---------------------|
| (1) A255-1 Weight | = | (8) AN970-4 Washers |
| (1) A255-2 Weight | = | (3) A255-1 Weights |

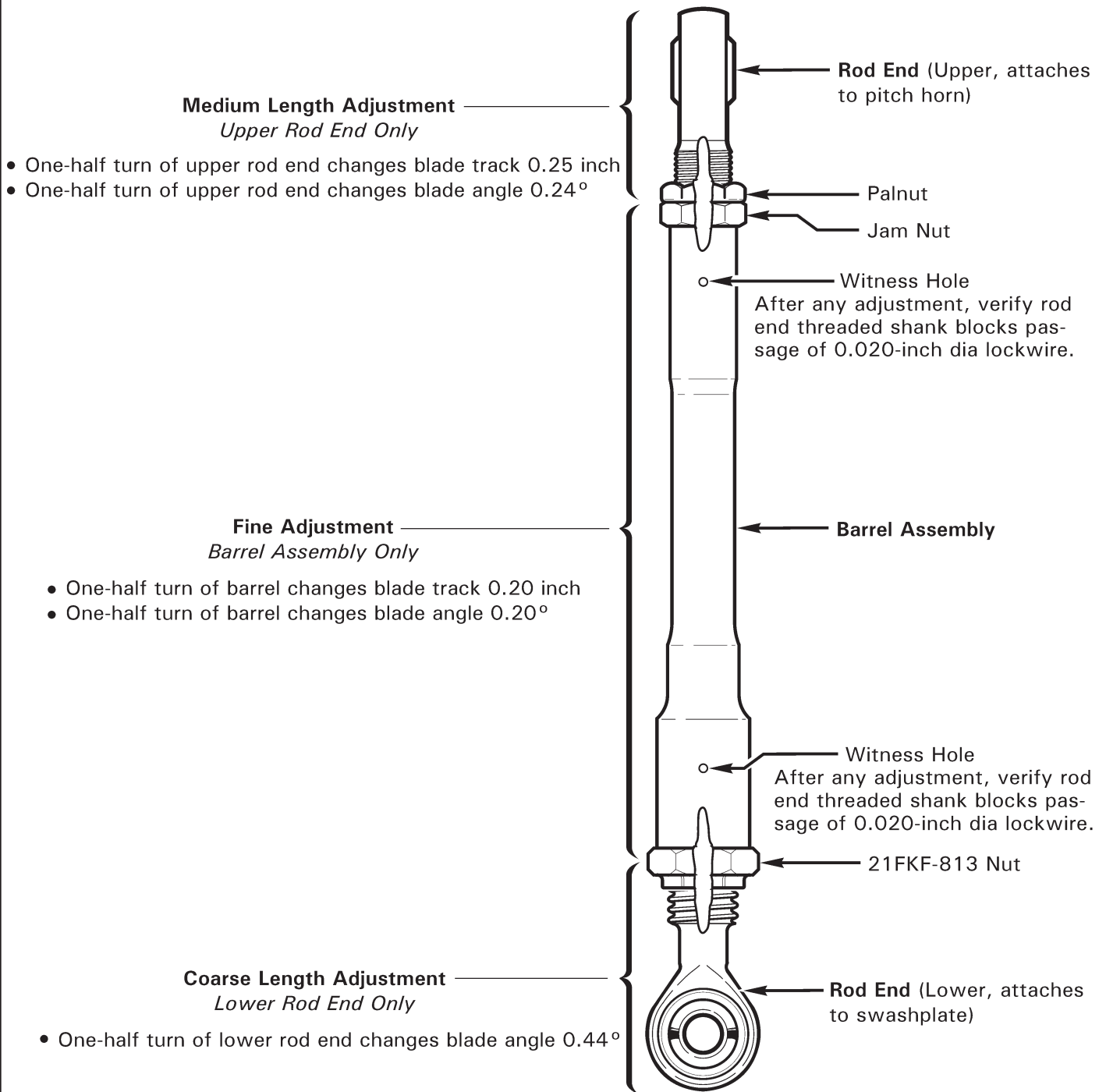

FIGURE 10-12A C258-5 MAIN ROTOR PITCH LINK

10.232 Main Rotor Pitch Link Adjustment

NOTE

Shorten high pitch blade when adjusting track in a hover.

NOTE

During rigging, adjust both pitch links exactly the same for collective adjustments.

1. For fine adjustment:

- a. C258-5 Pitch Link: Adjust barrel assembly only per the following steps:
 - i. Refer to Figure 10-12A. Using backup wrench on barrel assembly, loosen 21FKF-813 nut at lower rod end, and upper rod end palnut and jam nut.
 - ii. Rotate barrel assembly to shorten or lengthen pitch link as required. One-half turn of barrel changes blade track approximately 0.20 inch. One-half turn of barrel changes blade angle approximately 0.20°. For finer adjustment, rotate less than one-half turn as required.
 - iii. Refer to Figure 2-1. Verify rod end threaded shank blocks passage of 0.020-inch diameter lockwire through barrel assembly witness holes.
 - iv. Position rod ends to allow as much pitch link rotation as possible without binding. Using backup wrench on barrel assembly, special torque 21FKF-813 nut per § 23-33, and standard torque upper rod end jam nut and palnut per § 23-32.
 - v. Repeat steps on opposite pitch link as required; torque stripe per Figure 2-1.
- b. C258-1 Pitch Link: Adjust fitting only per the following:
 - i. Refer to Figure 10-12B. Cut and discard pitch link assembly safety wire. Using backup wrench on link assembly, loosen 21FKF-813 nut; using backup wrench on fitting, loosen upper rod end palnut and jam nut.
 - ii. Rotate fitting to shorten or lengthen pitch link as required. One-half turn of fitting changes blade track approximately 0.20 inch. One-half turn of fitting changes blade angle approximately 0.20°. For finer adjustment, rotate less than one-half turn as required.
 - iii. Refer to Figure 2-1. Verify rod end threaded shank blocks passage of 0.020-inch diameter lockwire through pitch link witness holes.
 - iv. Using backup wrench on link assembly, special torque 21FKF-813 nut per § 23-33. Using backup wrench on fitting, standard torque upper rod end jam nut and palnut per § 23-32. Safety fitting to link assembly using 0.032-inch diameter lockwire.
 - v. Repeat steps on opposite pitch link as required; torque stripe per Figure 2-1.

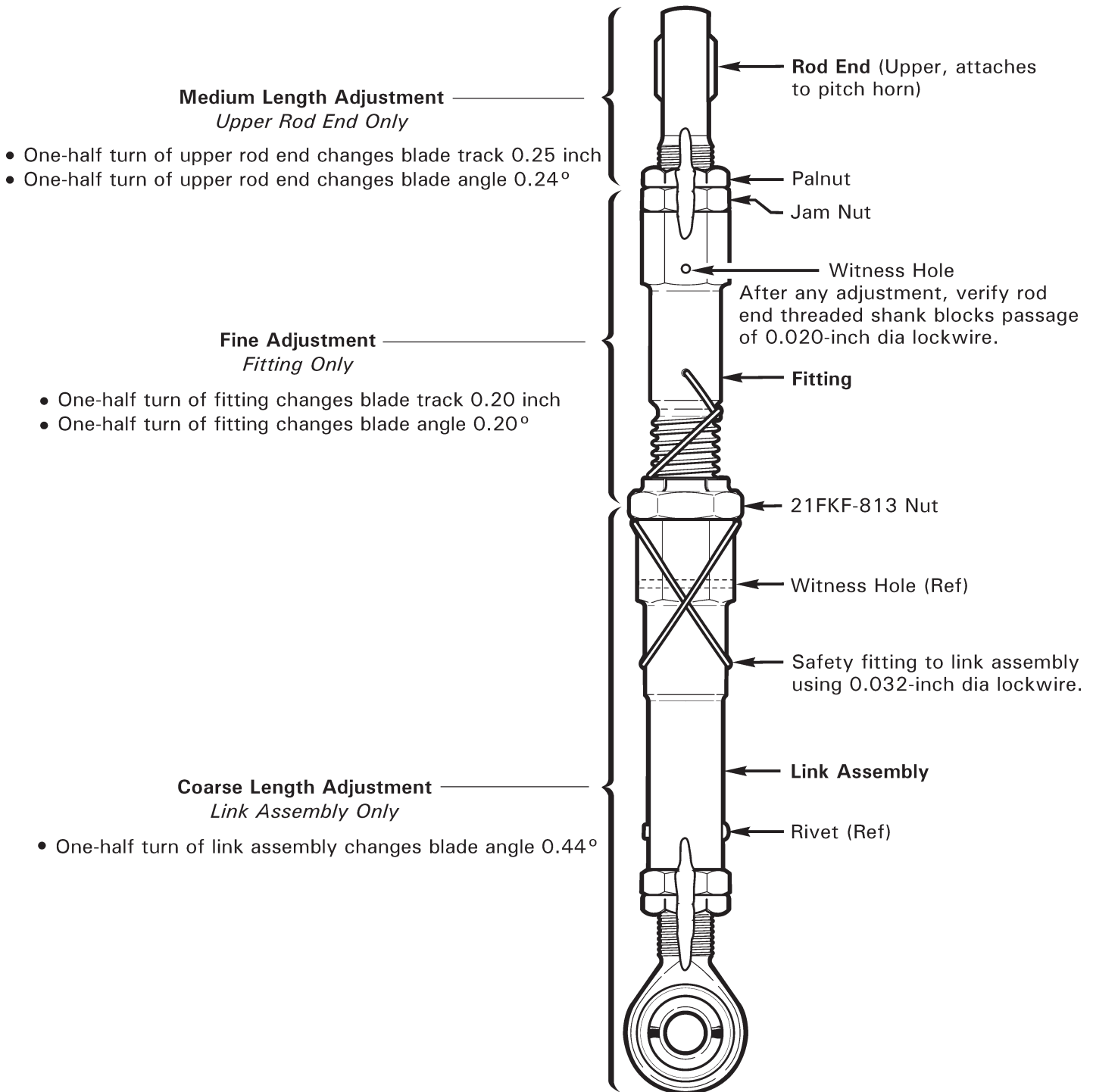

FIGURE 10-12B C258-1 MAIN ROTOR PITCH LINK

10.232 Main Rotor Pitch Link Adjustment (continued)

2. For medium length adjustment, adjust upper rod end per the following:
 - a. Refer to Figure 10-12A or 10-12B. Using backup wrench on barrel assembly or fitting, loosen upper rod end palnut and jam nut. Remove hardware securing rod end to pitch horn.
 - b. Rotate upper rod end to shorten or lengthen pitch link as required. One-half turn of upper rod end changes blade track approximately 0.25 inch. One-half turn of upper rod end changes blade angle by approximately 0.24° .
 - c. Refer to Figure 2-1. Verify rod end threaded shank blocks passage of 0.020-inch diameter lockwire through barrel assembly (upper), or fitting, witness hole. Install hardware securing rod end to pitch horn and standard torque fasteners per § 23-32.
 - d. Position rod ends to allow as much pitch link rotation as possible without binding. Using backup wrench on barrel assembly or fitting, standard torque upper rod end jam nut and palnut per § 23-32.
 - e. Repeat steps on opposite pitch link as required; torque stripe per Figure 2-1.
3. For coarse length adjustment:
 - a. C258-5 Pitch Link: Adjust lower rod end per the following:
 - i. Refer to Figure 10-12A. Using backup wrench on barrel assembly, loosen 21FKF-813 nut at lower rod end. Remove hardware securing lower rod end to swashplate.
 - ii. Rotate lower rod end to shorten or lengthen pitch link as required. One-half turn of lower rod end changes blade angle by approximately 0.44° .
 - iii. Refer to Figure 2-1. Verify rod end threaded shank blocks passage of 0.020-inch diameter lockwire through barrel assembly (lower) witness hole. Install hardware securing rod end to swashplate and standard torque fasteners per § 23-32.
 - iv. Position rod ends to allow as much pitch link rotation as possible without binding. Using backup wrench on barrel assembly, special torque 21FKF-813 nut per § 23-33.
 - v. Repeat steps on opposite pitch link as required; torque stripe per Figure 2-1.

10.232 Main Rotor Pitch Link Adjustment (continued)

3. b. C258-1 Pitch Link: Adjust link assembly per the following:
 - i. Refer to Figure 10-12B. Cut and discard pitch link assembly safety wire. Using backup wrench on link assembly, loosen 21FKF-813 nut. Remove hardware securing lower rod end to swashplate.
 - ii. Rotate link assembly to shorten or lengthen pitch link as required. One-half turn of link assembly changes blade angle by approximately 0.44° .
 - iii. Refer to Figure 2-1. Verify rod end threaded shank blocks passage of 0.020-inch diameter lockwire through link assembly witness hole. Install hardware securing rod end to swashplate and standard torque fasteners per § 23-32.
 - iv. Position rod ends to allow as much pitch link rotation as possible without binding. Using backup wrench on link assembly, special torque 21FKF-813 nut per § 23-33. Safety fitting to link assembly using 0.032-inch diameter lockwire.
 - v. Repeat steps on opposite pitch link as required; torque stripe per Figure 2-1.

Intentionally Blank

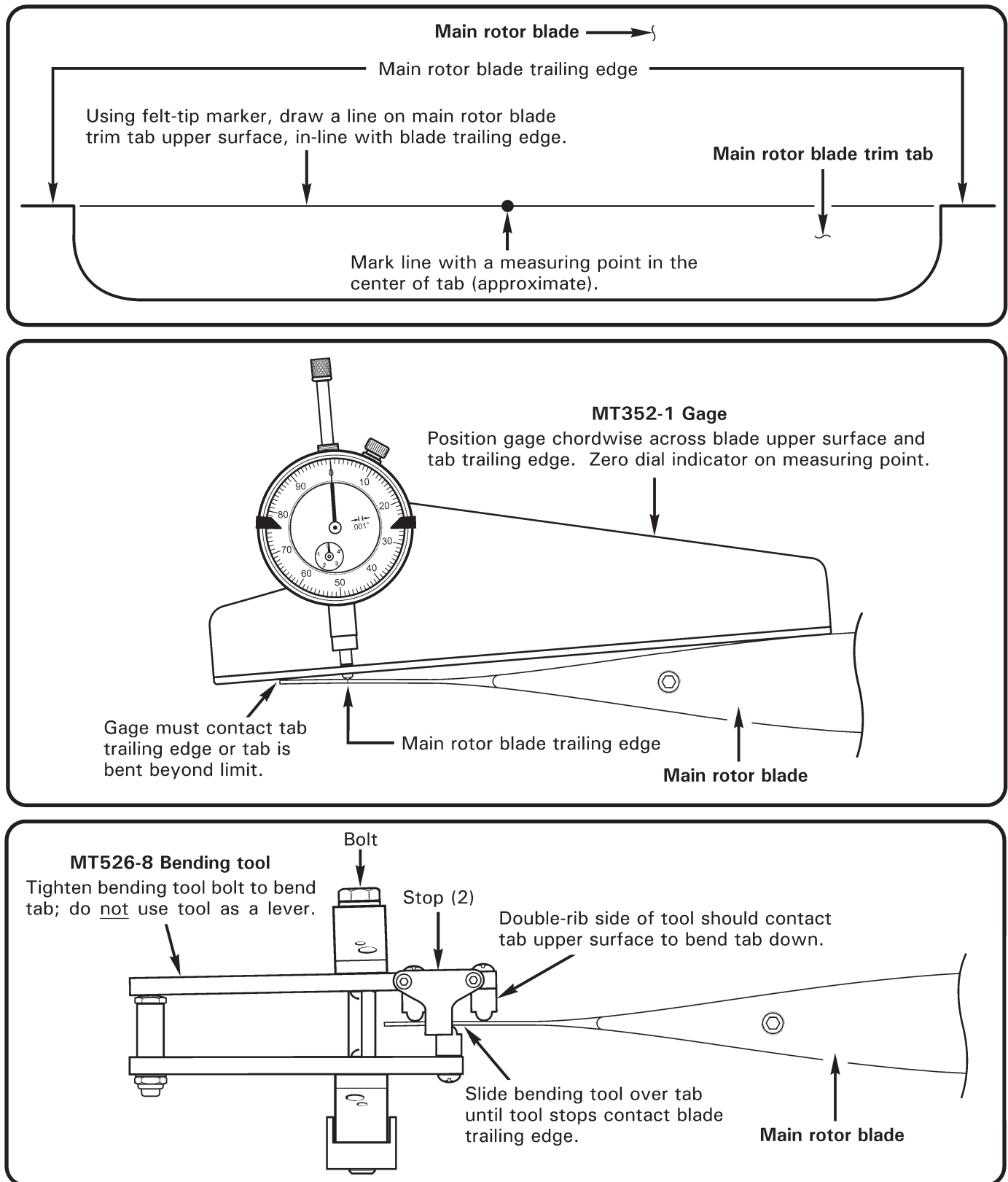

FIGURE 10-13 MAIN ROTOR BLADE TRIM TAB

10.233 Main Rotor Blade Trim Tab Adjustment**NOTE**

To correct for a "climbing" blade condition (blade spread that exceeds 3/8 inch with forward airspeed), bend high blade trim tab down.

CAUTION

Do not use other helicopter manufacturers' trim tab bending tools. Use of these tools will damage Robinson blades.

CAUTION

MT352-1 gage must contact trim tab trailing edge. If gage does not contact tab trailing edge, tab is bent beyond limit.

CAUTION

Tighten MT526-8 bending tool bolt to bend tab; do not use tool as a lever.

CAUTION

Bend tab upward only when absolutely necessary; bending tab upward can increase rotor vibration.

1. Using felt tip marker, ink mark main rotor blade trim tab per Figure 10-13. Mark line with a measuring point in the center of the tab (approximate).
2. Position MT352-1 gage chordwise across blade upper surface and tab trailing edge. Zero dial indicator on measuring point.
3. Position MT526-8 bending tool on tab per Figure 10-13. Slide tool completely over tab until tool stops contact blade trailing edge. Double-rib side of tool should contact tab upper surface to bend tab down. Double-rib side of tool should contact tab bottom surface to bend tab up.
4. Tighten MT526-8 bending tool bolt to bend tab. Make slight bends and re-measure tab with MT352-1 gage. Bend trim tab 0.015 inch (down) to effect dynamic movement of main rotor blade tip approximately 0.2 inch (downward).

10.234 Main Rotor Track and Balance Troubleshooting

SYMPTOM	PROBABLE CAUSE	CORRECTION
Excessive Cyclic or Stick Shake	Rough or binding A205-5 fork assembly (upper swashplate).	Replace or refer to § 8.600.
	Brinelled spindle bearing (rough movement).	Send blade(s) to RHC or Service Center for spindle bearing replacement.
	Rough blade surface (chipped paint).	Repair blades per § 28-50.
	Rough or binding pitch links.	Replace pitch link rod ends.
	MR blade boot misaligned.	Realign or replace boot per §§ 28-11.
	MR teeter or coning hinge binding.	Replace bearings per § 28-21.
	MR blade trim tabs bent upward.	Bend trim tabs evenly down per § 10.233.
	Blade mismatch.	Send blade(s) to RHC for replacement.
Excessive Ship Vibration	MR out of track and balance.	Track and balance per § 10.230.
	MR teeter or coning hinge friction.	Adjust hinge friction per § 28-32.
	MR teeter or coning hinge binding.	Replace bearings per § 28-21.
	Brinelled spindle bearing (rough movement).	Send blade(s) to RHC or Service Center for spindle bearing replacement.
	MR teeter hinge bearings worn.	Replace bearings per § 28-21.
Excessive Cyclic Stick Forces	Brinelled spindle bearing (rough movement).	Send blade(s) to RHC or Service Center for spindle bearing replacement.
Intermittent Blade Track Picture	MR teeter or coning hinge friction	Adjust hinge friction per § 28-32.
	MR coning hinge binding.	Replace bearings per § 28-21.
	MR teeter hinge not "broken-in."	Track and balance per § 10.230. Adjust track to minimize error.
	Brinelled spindle bearing (rough movement).	Send blade(s) to RHC or Service Center for spindle bearing replacement.
Radical Changes to Cyclic Trim	MR teeter hinge bearings worn.	Replace bearings per § 28-21.
	Brinelled spindle bearing (rough movement).	Send blade(s) to RHC for spindle bearing replacement.
Lateral Intermittent Ship Vibration	Engine misfiring due to malfunction in spark plugs, ignition leads, magneto, or engine not "broken-in."	Refer to Textron-Lycoming Maintenance Instructions.
4 per second Fore/Aft Oscillation	Aircraft CG out of limits.	Operate aircraft within CG envelope.
	Deteriorated / contaminated main gearbox rubber mount(s).	Replace main gearbox mounts.

Intentionally Blank

10.240 Tail Rotor Balance Procedure

Refer to specific manufacturer's installation instructions when using balancing equipment other than Chadwick-Helmuth Vibrex system.

Install Chadwick-Helmuth equipment per § 10.222. Set Function Knob on Balancer to appropriate channel. Set balancer RPM Range knob to X10 and set RPM to 231. With helicopter running with governor ON, view tail rotor assembly with Strobex. Tune Balancer while viewing target tape and adjusting RPM dial on Balancer. Record clock angle and IPS on tail rotor balance chart. Adjust as required until balance is less than 0.2 IPS.

Spanwise balance adjustments for C029-1 square-tip blades are made by adding, subtracting, or exchanging weights under the removable tip cover. Use C134-1 or -2 tip weights or AN960-8 or -8L washers. -8L washers may be trimmed as a very fine adjustment.

Spanwise balance adjustments for C029-2 and C029-3 round-tip blades are made by exchanging different diameter washers under nut securing blade's outboard retaining bolt. The bolt has sufficient length to allow necessary spanwise weight changes; verify 2–4 threads protruding past nut after torquing per § 23-32.

Chordwise balance is adjusted by adding, subtracting, or exchanging A141-14, A214-3, NAS1149F0463P/F0432P, or NAS1149D0463J/D0432J washers under nut securing blade's pitch link attaching bolt. Change pitch link attaching bolt length as required for proper thread engagement (see § 23-30, refer to IPC for allowable lengths).

DATE _____ SERIAL NO. _____
 PAGE _____

C008-9 TAIL ROTOR ASSEMBLY

CHORDWISE WEIGHTS			
(1) NAS1149F0463P Washer	=	(2)	NAS1149F0432P Washers
(1) A214-3 Washer	=	(3.5)	NAS1149F0432P Washers
(1) A141-14 Washer	=	(5)	NAS1149F0432P Washers

SPANWISE WEIGHTS			
(1) C141-23 Washer	=	(3.5)	NAS1149F0663P Washers
(1) C141-24 Washer	=	(7)	NAS1149F0663P Washers
(2) NAS1149F0632P		(1)	NAS1149F0663P Washer

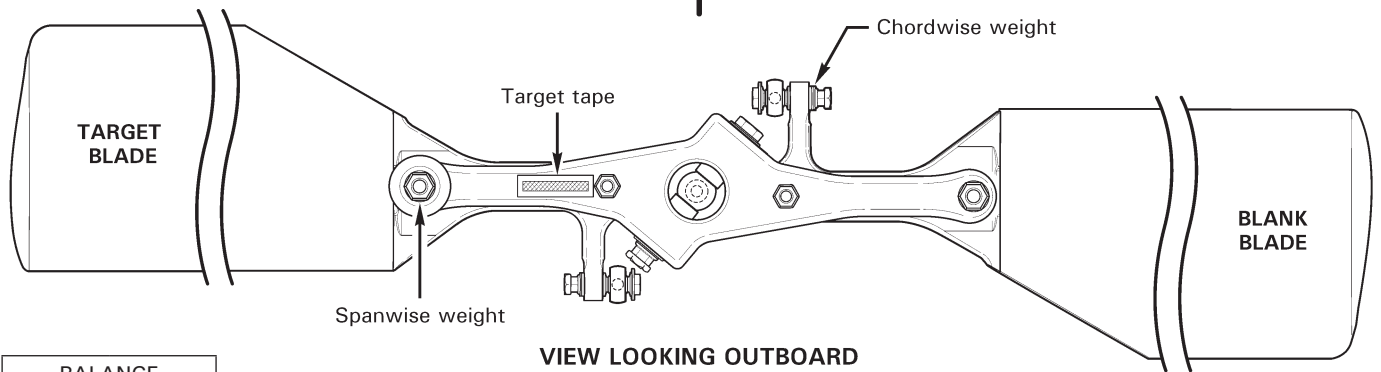
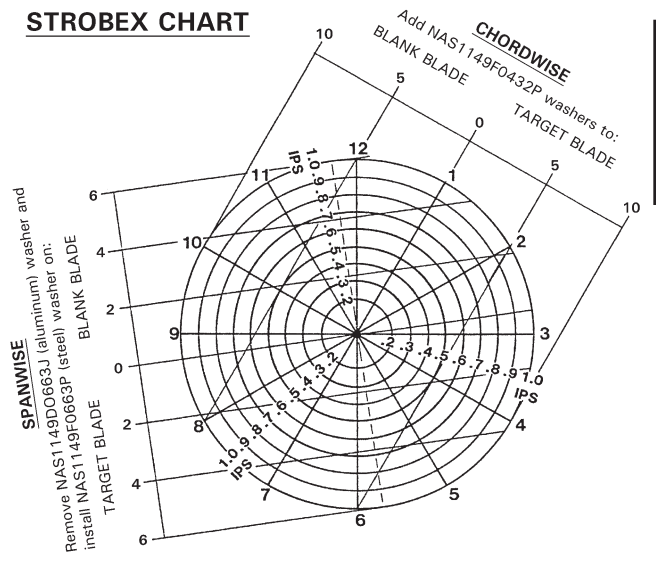
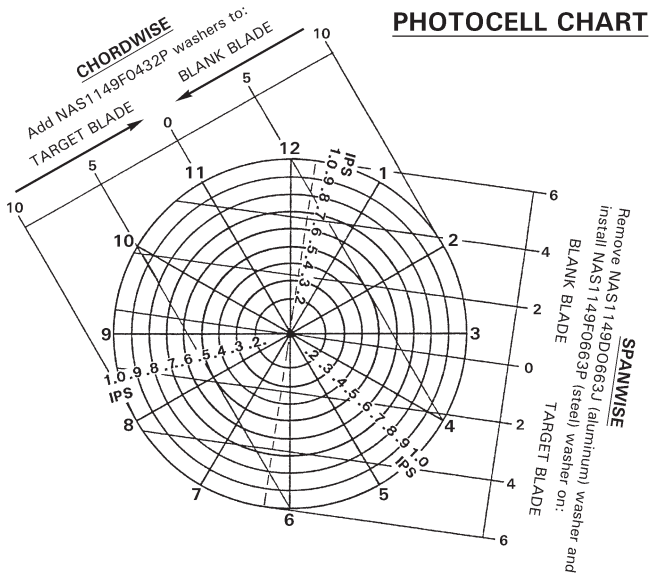

BALANCE	
CLOCK	IPS
CLOCK	IPS
CLOCK	IPS
CLOCK	IPS

ADJUSTMENT: _____

ADJUSTMENT: _____

ADJUSTMENT: _____

ADJUSTMENT: _____

FIGURE 10-14 C008-9 TAIL ROTOR ASSEMBLY DYNAMIC BALANCE CHART

DATE _____ SERIAL NO. _____
 PAGE _____

C008-4 TAIL ROTOR ASSEMBLY

CHORDWISE WEIGHTS			
(1) NAS1149F0463P Washer	=	(2)	NAS1149F0432P Washers
(1) A214-3 Washer	=	(3.5)	NAS1149F0432P Washers
(1) A141-14 Washer	=	(5)	NAS1149F0432P Washers

SPANWISE WEIGHTS			
(1) C141-20 Washer	=	(5)	NAS1149F0563P Washers
(1) AN970-5 Washer	=	(13)	NAS1149F0563P Washers

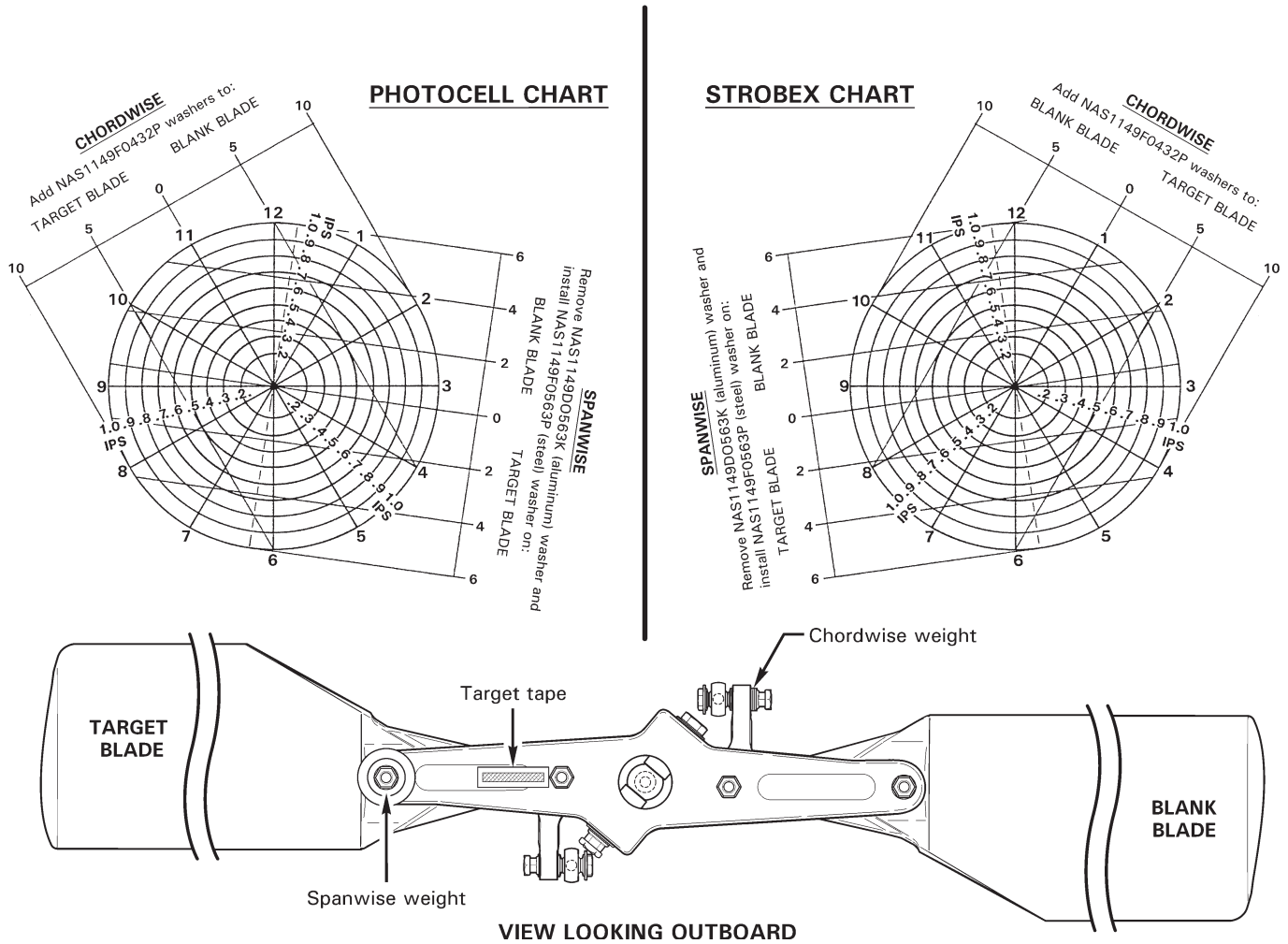

BALANCE	
CLOCK	IPS
CLOCK	IPS
CLOCK	IPS
CLOCK	IPS

ADJUSTMENT: _____

ADJUSTMENT: _____

ADJUSTMENT: _____

ADJUSTMENT: _____

FIGURE 10-15 C008-4 TAIL ROTOR ASSEMBLY DYNAMIC BALANCE CHART

DATE _____ SERIAL NO. _____
 PAGE _____

C008-2 TAIL ROTOR ASSEMBLY

CHORDWISE WEIGHTS			
(1) NAS1149F0463P Washer	=	(2)	NAS1149F0432P Washers
(1) A141-14 Washer	=	(5)	NAS1149F0432P Washers

SPANWISE WEIGHTS			
(1) NAS1149FN832P	=	(2)	NAS1149FN816P Washers
(1) C134-1 Weight	=	(14)	NAS1149FN816P Washers

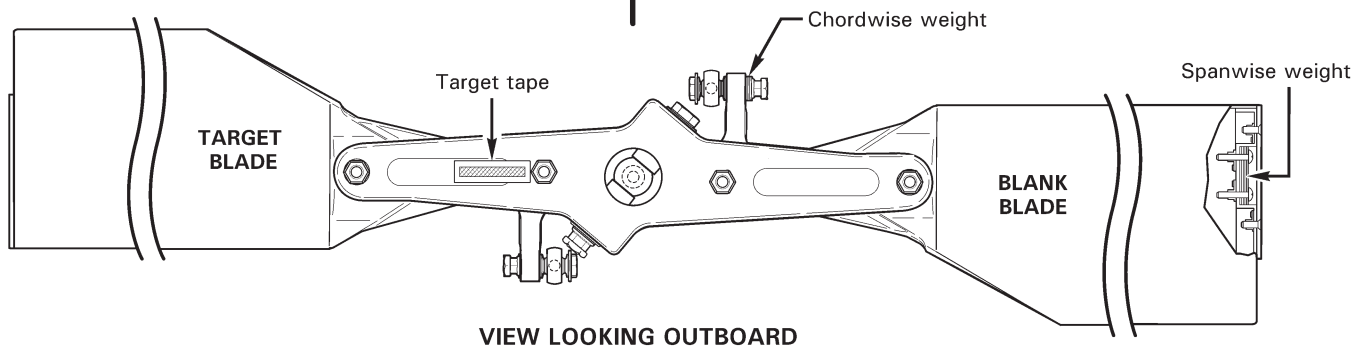
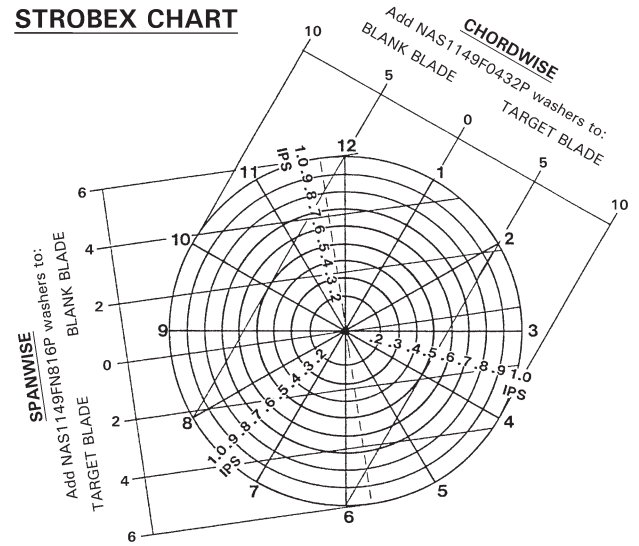
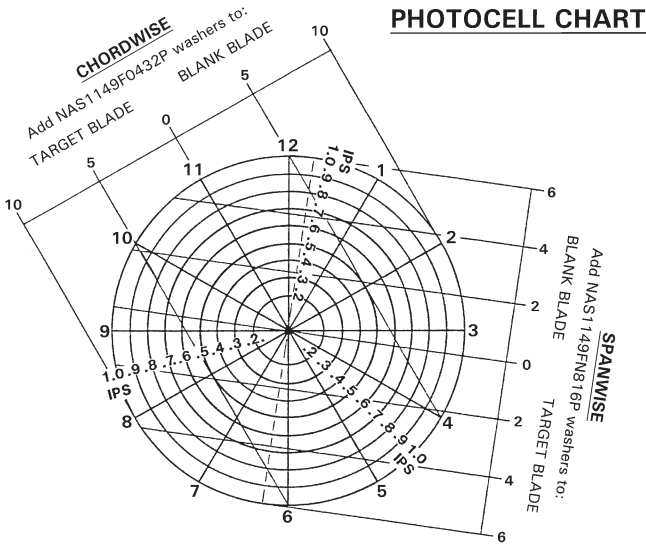

BALANCE	
CLOCK	IPS
CLOCK	IPS
CLOCK	IPS
CLOCK	IPS

ADJUSTMENT: _____

ADJUSTMENT: _____

ADJUSTMENT: _____

ADJUSTMENT: _____

FIGURE 10-16 C008-2 TAIL ROTOR ASSEMBLY DYNAMIC BALANCE CHART

Intentionally Blank

10.250 Autorotational RPM Adjustment

Use the following procedure for checking and adjusting autorotational RPM:

WARNING

Failure to properly adjust autorotational RPM (RPM too low) may prevent the rotorcraft from achieving proper RPM at low gross weights.

NOTE

Weight onboard = combined weight of fuel, people, & cargo onboard the helicopter.

1. Perform autorotation RPM check at less than 1900 lb gross weight. Calculate the weight onboard of the helicopter. Record the time on the hourmeter.

Weight onboard at take-off _____

Take-Off hourmeter reading _____

2. Set the altimeter to 29.92" Hg (1013.2 millibars) prior to performing the autorotation. Autorotate with the collective control firmly held against the down stop with an airspeed of 50 KIAS.

WARNING

Do not allow the rotor to overspeed when performing autorotation checks. Progressively lengthen both main rotor pitch link rod ends until full down collective can be obtained without overspeeding the rotor.

Take at least 3 RPM readings at 500 to 1000 foot altitude intervals. Record the following in-flight data:

Test No.	1	2	3	4	5
Hourmeter Reading					
OAT					
Pressure Altitude					
Test %RPM					

10.250 Autorotational RPM Adjustment (continued)

3. After test flight, refer to Figure 10-17 chart and determine following:

Test No.	1	2	3	4	5
Elapsed Time (in-flight hourmeter reading minus take-off hourmeter reading)					
lbs of Fuel Consumed (elapsed time x 93 lb/hr)					
Weight onboard (take-off weight onboard minus fuel consumed)					
Test Longitudinal Center of Gravity					
Chart % RPM					
Test % RPM (from in-flight data)					
RPM Correction (chart % RPM minus Test % RPM)					

* Chart Instructions:

- a. Start at outside air temperature, and draw a vertical line up to pressure altitude.
- b. Draw a horizontal line from pressure altitude to weight onboard at time of autorotation.
- c. Draw a vertical line down from weight onboard to required auto RPM.

Note: Increase rotor RPM 0.75% for every inch that CG is forward of FS 100.0.

4. Adjust pitch links based on average RPM correction required. Lengthen both pitch links to decrease RPM if test RPM is greater than chart RPM; shorten both pitch links to increase RPM. One full turn of upper rod end will change RPM approximately 3 1/2 %. Adjust both pitch links exactly the same so track will not be affected.
5. Repeat steps 1 thru 4 as required until the RPM correction is ± 1% of chart RPM.

R44 AUTOROTATION RPM

COLLECTIVE FULL DOWN

50 KIAS

One full turn of barrel = approximately 3% RPM change

One full turn of upper rod end = approximately 3½ % RPM change

Note: Increase Rotor RPM 0.75% for every inch that CG is forwrd of FS 100.0.

Example: OAT = 20°C, Hp = 2000 ft, Weight on board = 300 lb, CG = FS 98.0

Target RPM = 99% + (2 x 0.75%) = 100.5%

FIGURE 10-17 R44 AUTOROTATION RPM

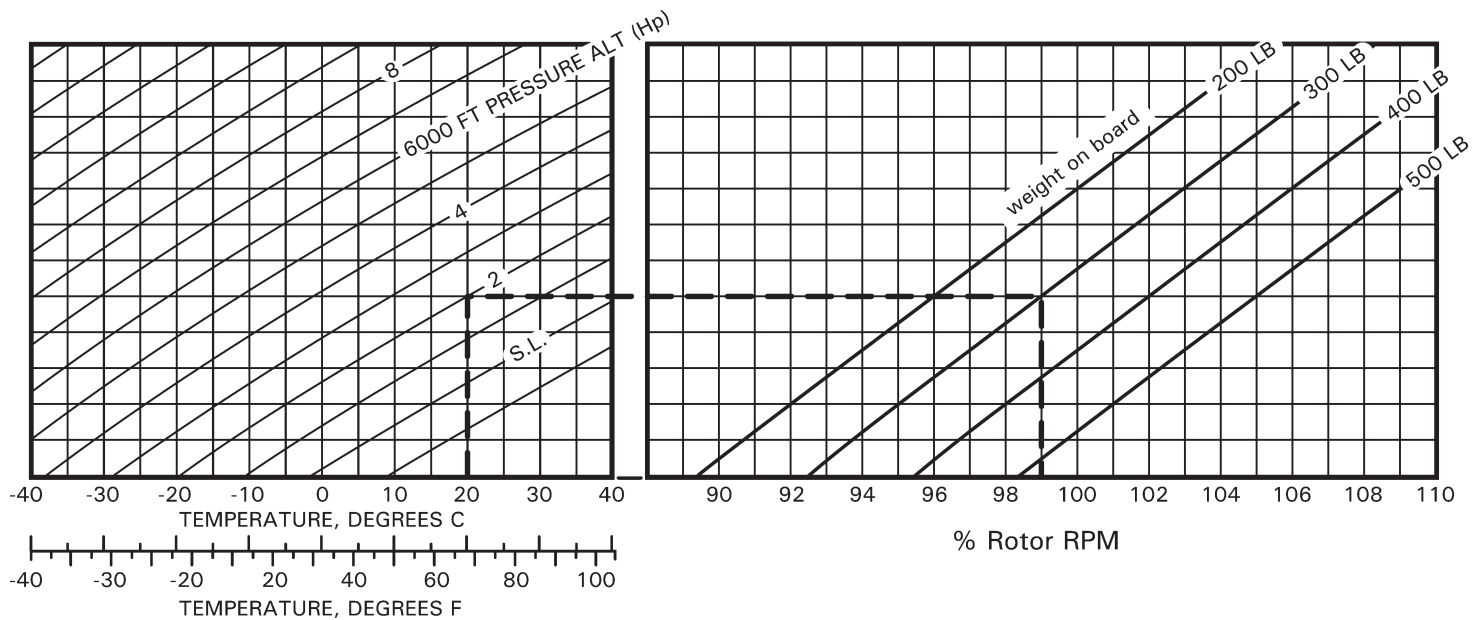

Intentionally Blank

CHAPTER 11**ENVIRONMENTAL CONTROL**

<u>Section</u>	<u>Title</u>	<u>Page</u>
11.000	Heating and Ventilation	11.1
11.001	Introduction	11.1
11.002	Description	11.1
11.100	Cabin Heater	11.1
11.110	Control Cable and Valve Replacement	11.1
11.120	Muffler Shroud Replacement	11.5
11.200	Ventilation	11.5
11.210	Cabin Air Vent Cable Removal	11.5
11.220	Cabin Air Vent Cable Installation	11.5
11.230	Door Vent	11.5
11.300	Air Conditioning	11.7
11.310	System Troubleshooting	11.9
11.320	Refrigerant	11.11
11.321	Refrigerant Recovery	11.11
11.322	Refrigerant Charge	11.11
11.323	Leak Detection	11.12
11.330	Compressor	11.13
11.331	Compressor Belt Replacement	11.13
11.332	Compressor Removal	11.13
11.333	Compressor Installation	11.14
11.340	Evaporator Assembly	11.16
11.341	Evaporator Assembly Removal	11.16
11.342	Evaporator Assembly Installation	11.17
11.343	Evaporator Drain System	11.18
11.350	Full Throttle Cut-Out Switch Rigging	11.20
11.400	Drive Cartridge	11.21
11.410	Drive Cartridge Seal Removal	11.21
11.420	Drive Cartridge Seal Installation	11.21

Intentionally Blank

CHAPTER 11

HEATING , VENTILATION AND AIR CONDITIONING

11.000 Heating and Ventilation11.001 Introduction

This section contains the procedures necessary for replacement of the heater and ventilation systems components.

11.002 Description

The cabin heater system consists of a heat shroud over the muffler, a control valve on the forward side of the firewall, an outlet grill forward of the pilot's tail rotor pedals, and the interconnecting ducts between components. Air is supplied by the engine cooling fan. The push-pull heat control is located on the face of the lower console. The heat control actuates the control valve which directs the air either into the cabin or out an overboard discharge on the underside of the cabin.

Fresh air vents are located in each door and in the nose of the helicopter. A push-pull control for the nose vent is located on the face of the lower console.

11.100 Cabin Heater

Refer to Figure 11-1.

NOTE

The cabin heater is required to be installed in the R44 helicopter. Air flow through the muffler shroud cools the muffler and engine compartment.

11.110 Control Cable and Valve Replacement

1. Remove the aft tunnel belly panel and engine belly cowling.
2. Remove the three screws holding the C753-1 cover and remove the cover and insulation.
3. Remove four screws holding the C625-1 box and remove the box.
4. Remove the control wire by straightening the end (if applicable) and loosening the A462-1 fitting clamping the wire.
5. To remove the A019-3 valve assembly and A623-1 inlet, remove the two hoses and the remaining four screws through the firewall.
6. To remove the control cable casing, open upper console. Remove the cable jam nut behind the lower console face and the AN742-3 clamp holding the casing to the chin. Inside the right forward baggage compartment, remove the clamp. Outboard of the right aft floor, remove the outboard carpet from the top to access the cable casing. Remove the two clamps under the panel outboard of the right aft seat. Remove the clamp holding the casing to the vertical firewall and pull the casing out through the lower console face.

11.110 Control Cable and Valve Replacement (continued)

7. To install the control cable casing, verify that an MS35489-4 or AN931-3-5 grommet is installed in the tunnel wall next to the valve and an NAS557-3A grommet is installed 6 places in holes through which the casing passes (each place except one place through a vertical firewall stiffener and through the bulkhead at the front of the right forward baggage compartment). Install the casing through the lower console face and cable jam nut, through the stiffener on the side of the console, through the right forward baggage compartment, outboard of the right aft floor, through the right aft baggage compartment, through two stiffeners on the vertical firewall, and into the tunnel. Set end of casing approximately 0.8 inches into the tunnel. Fasten casing with AN742-3 clamps five places.
8. To install the valve and inlet, clean off the old sealant and reseal with B270-4 sealant. Install valve and inlet and fasten with screws in four places.
9. Install control cable wire through the A462-1 fitting and adjust to give approximately 0.060 springback at the knob when the valve is fully closed. Verify control operates freely. Cut excess wire approximately 0.01 inch or less from the fitting.
10. Install the C625-1 box and seal with B270-1 sealant. Verify the valve and box are sealed by taping the belly hole closed and applying low air pressure to the inlet. Check for leaks inside the tunnel by using a piece of yarn at the end of a stick.
11. Install one inch thick Microlite AA insulation over the C625-1 box and install the C753-1 cover.
12. Install heater hoses. Install belly cowling, belly cover, and close upper console.

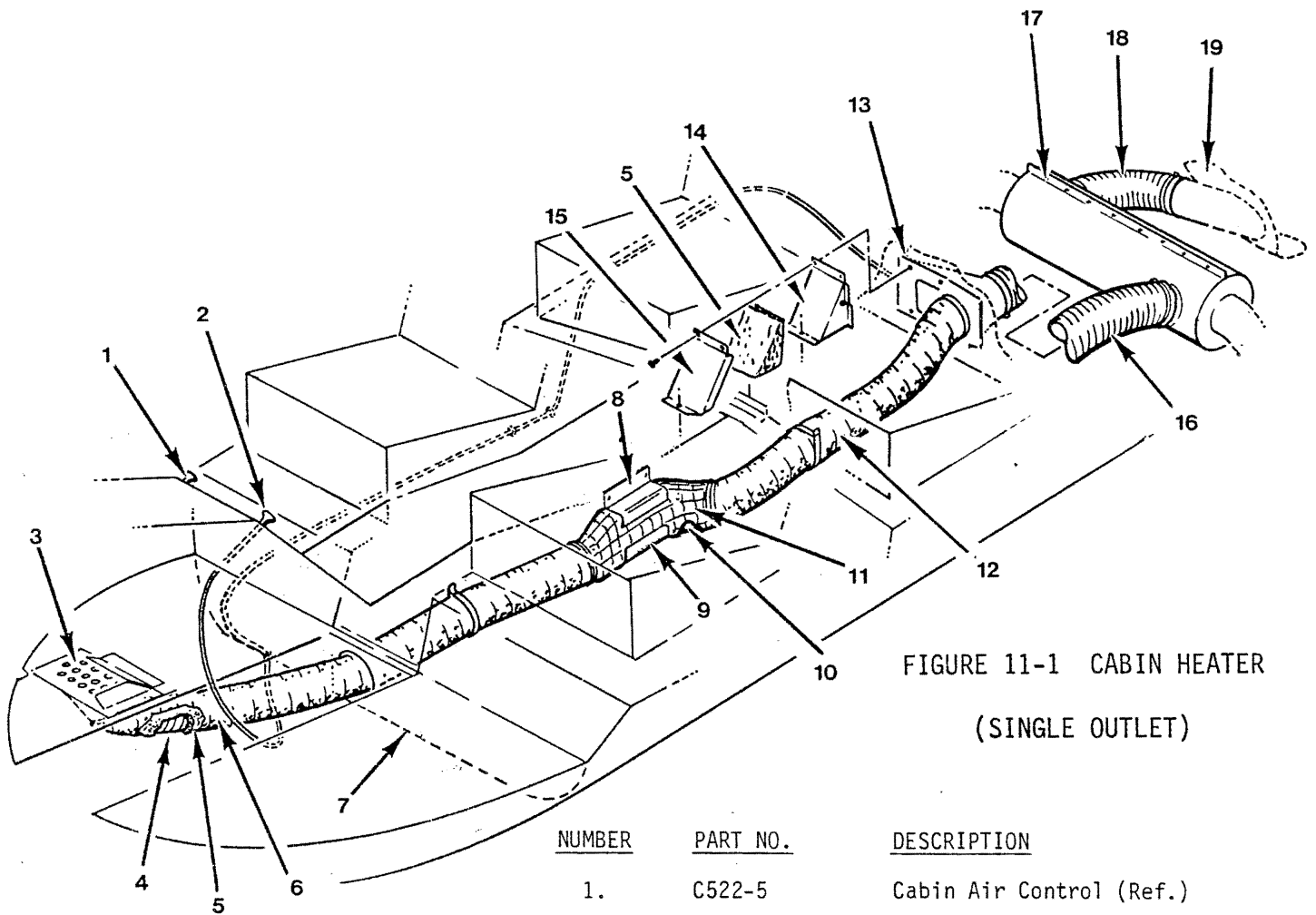

**FIGURE 11-1 CABIN HEATER
(SINGLE OUTLET)**

<u>NUMBER</u>	<u>PART NO.</u>	<u>DESCRIPTION</u>
1.	C522-5	Cabin Air Control (Ref.)
2.	A522-8	Cabin Heater Control
3.	B164-1	Heater Outlet
4.	A785-15	Hose
5.	R111	Insulation
6.	A701-1	Foil Tape (Forward of item 7)
	A701-2	Foil Tape (Aft of item 7)
7.	D230-1	Bulkhead (Ref.)
8.	C631-2	Clip
9.	C631-1	Clip
10.	D164-1	Duct
11.	C630-1	Insulation
12.	A785-14	Hose
13.	A019-3	Valve Assembly
14.	C625-1	Box
15.	A753-1	Cover
16.	A758-13	Hose
17.	C169-2	Shroud Assembly
18.	A785-12	Hose
19.	C236	Cooling Scroll (Ref.)

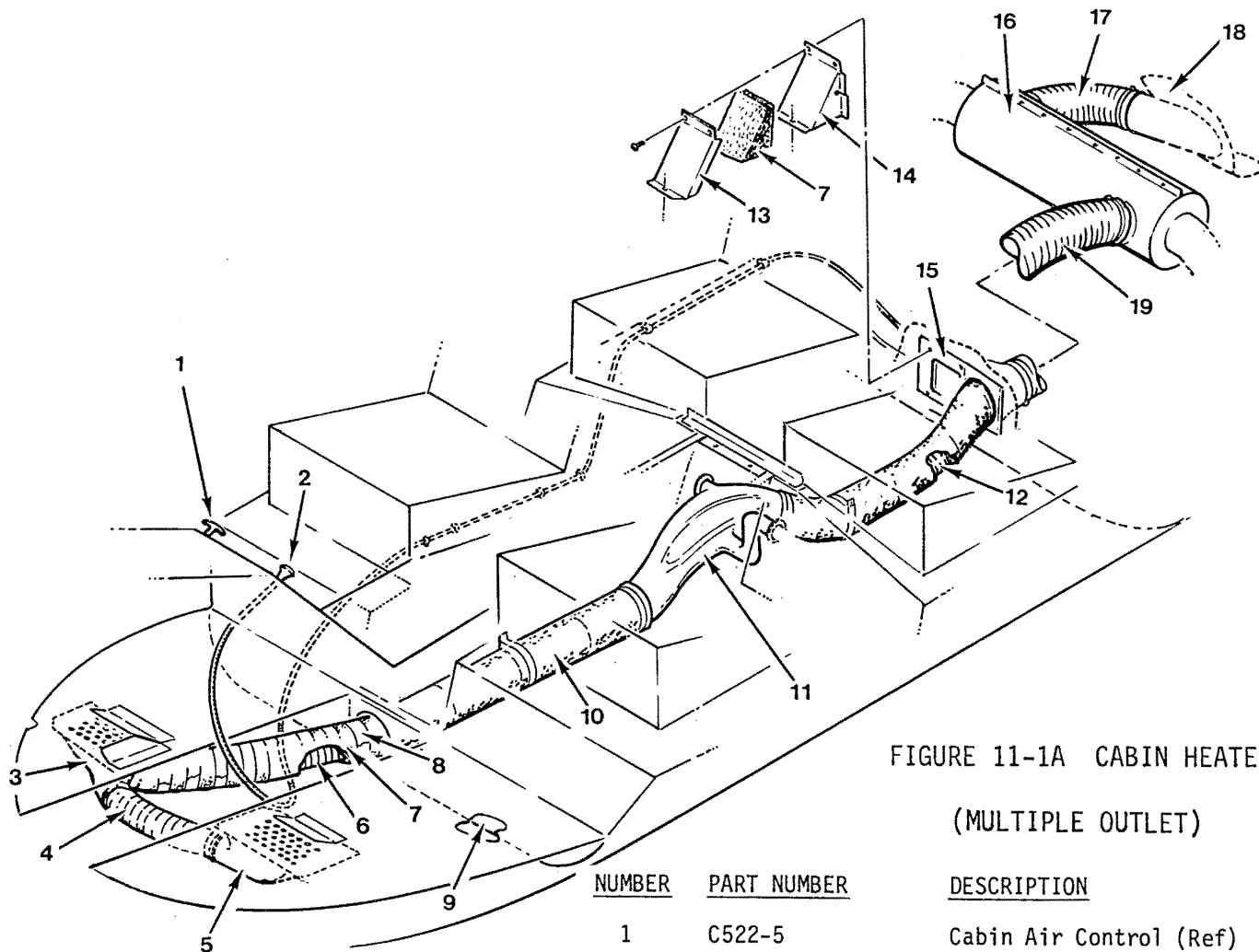

**FIGURE 11-1A CABIN HEATER
(MULTIPLE OUTLET)**

<u>NUMBER</u>	<u>PART NUMBER</u>	<u>DESCRIPTION</u>
1	C522-5	Cabin Air Control (Ref)
2	A522-8	Cabin Heater Control
3	D164-1	Heater Outlet
4	A785-24	Hose
5	D166-1	Outlet (LH)
6	A785-23	Hose
7	R111	Insulation
8	A701-1	Foil Tape (Forward of item 9)
9	D230-1	Bulkhead (Ref)
10	A701-2	Foil Tape (Aft of item 9)
11	D164-2	Duct
12	A785-14	Hose
13	C753-1	Cover
14	C625-1	Box
15	A019-1	Valve Assembly
16	C169-2	Shroud Assembly
17	A785-12	Hose
18	C236	Cooling Scroll
19	A785-13	Hose

11.120 Muffler Shroud Replacement

- a) Remove the D040-1 aft engine cowling.
- b) Remove the tail pipe from the exhaust hanger at the engine cooling scroll.
- c) Disconnect the two heater hoses from the shroud.
- d) Remove the screws at the top of the shroud and remove the shroud over the tail pipe.
- e) To install the shroud, reverse steps a through d.

11.200 VENTILATION

11.210 Cabin Air Vent Cable Removal (See Figure 11-2)

- a) Open upper console.
- b) Remove cotter pin and clevis pin at the forward cabin vent.
- c) Remove attaching clamps.
- d) Remove cable jam nut at lower console face and remove cable.

11.220 Cabin Air Vent Cable Installation (See Figure 11-2)

- a) Install or replace the MS3548-4 grommet in the vent box, if required.
- b) Insert the A5225-5 cable through the hole in the lower console and tighten the jam nut.
- c) Secure the control wire to the vent door using one MS20392-2C13 clevis pin and one MS24665-73 cotter pin.
- d) Install the cable clamps. Adjust cable casing for proper operation of vent. Then tighten clamps securely to insure casing does not slide when operating the vent control knob.
- e) Close and secure upper console.

11.230 Door Vent (See Figure 11-3)

The door vent hinge is riveted in place and can be replaced, if damaged, by drilling out the rivets and replacing the vent door and/or hinge as required.

The A226-3 seal around the vent door can be replaced if damaged using B270-4 or B270-13 adhesive.

The friction can be adjusted on the door vent by tightening the NAS1291-08 nut holding the knob on the center pivot of the double arm linkage.

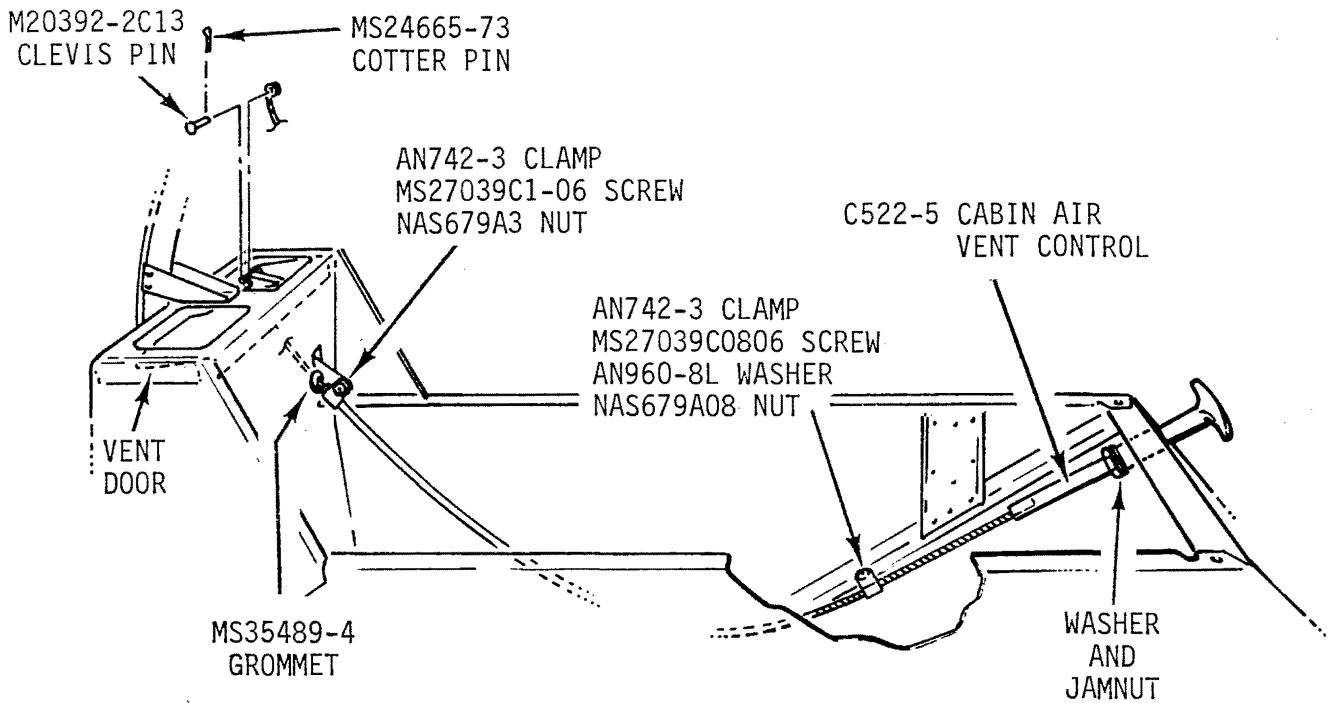

FIGURE 11-2 CABIN AIR VENT INSTALLATION

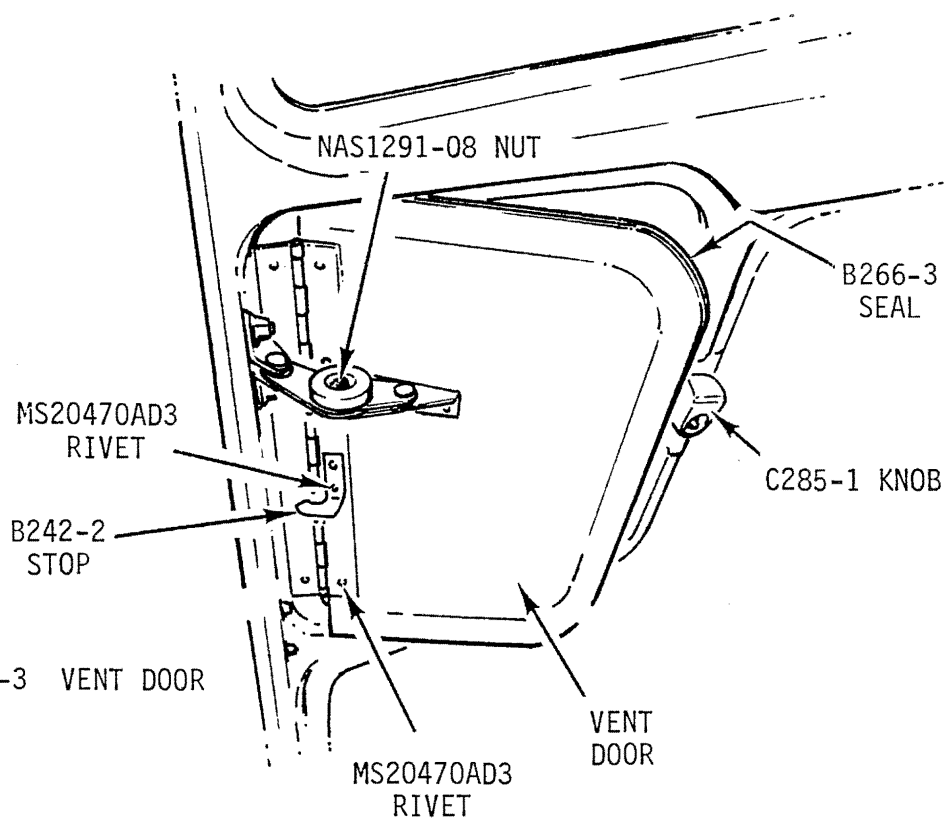

FIGURE 11-3 VENT DOOR

11.300 Air Conditioning

NOTE

Air conditioning service procedures and required equipment are generally similar to those for standard R134a automotive systems. In the United States, only personnel with EPA certification under Section 609 of the Clean Air Act may charge the system with refrigerant or work on the refrigerant system once it has been charged. Different requirements may apply in countries other than the United States.

A. Description

The optional cabin air conditioning system is shown schematically in Figures 11-4 & 11-4A. The system is similar to conventional automotive and light aircraft systems and consists of a compressor accessible through the left engine cowl door, a condenser mounted on the left side of the engine cooling fan scroll, an evaporator and fan assembly mounted to the aft cabin wall, an overhead outlet duct, and interconnecting lines and hoses. The system uses R134a refrigerant.

The compressor is belt-driven from an engine accessory drive cartridge and equipped with an electromagnetic clutch. When the system is off, the compressor clutch is disengaged, allowing the compressor pulley to freewheel.

The evaporator fan draws warm cabin air through the evaporator inlet grill and evaporator where it is cooled. Cooled air is drawn through the fan and blown through the overhead duct.

The system is controlled by a toggle switch on the overhead duct which allows selection of off, low, and high fan settings. The compressor is automatically engaged by switching the fan on. A temperature (freeze) switch disengages the compressor when evaporator temperature drops below freezing. Safety (pressure) switches disengage the compressor if excessive refrigerant leakage occurs or if refrigerant pressure is excessive. A full-throttle switch disengages the compressor when the engine is near full throttle to ensure that aircraft performance is not affected. The compressor clutch and fan circuits are protected by the A/C circuit breaker. Later helicopters also have a 3-amp fuse to protect the relays and a 10-amp fuse to protect the compressor circuit.

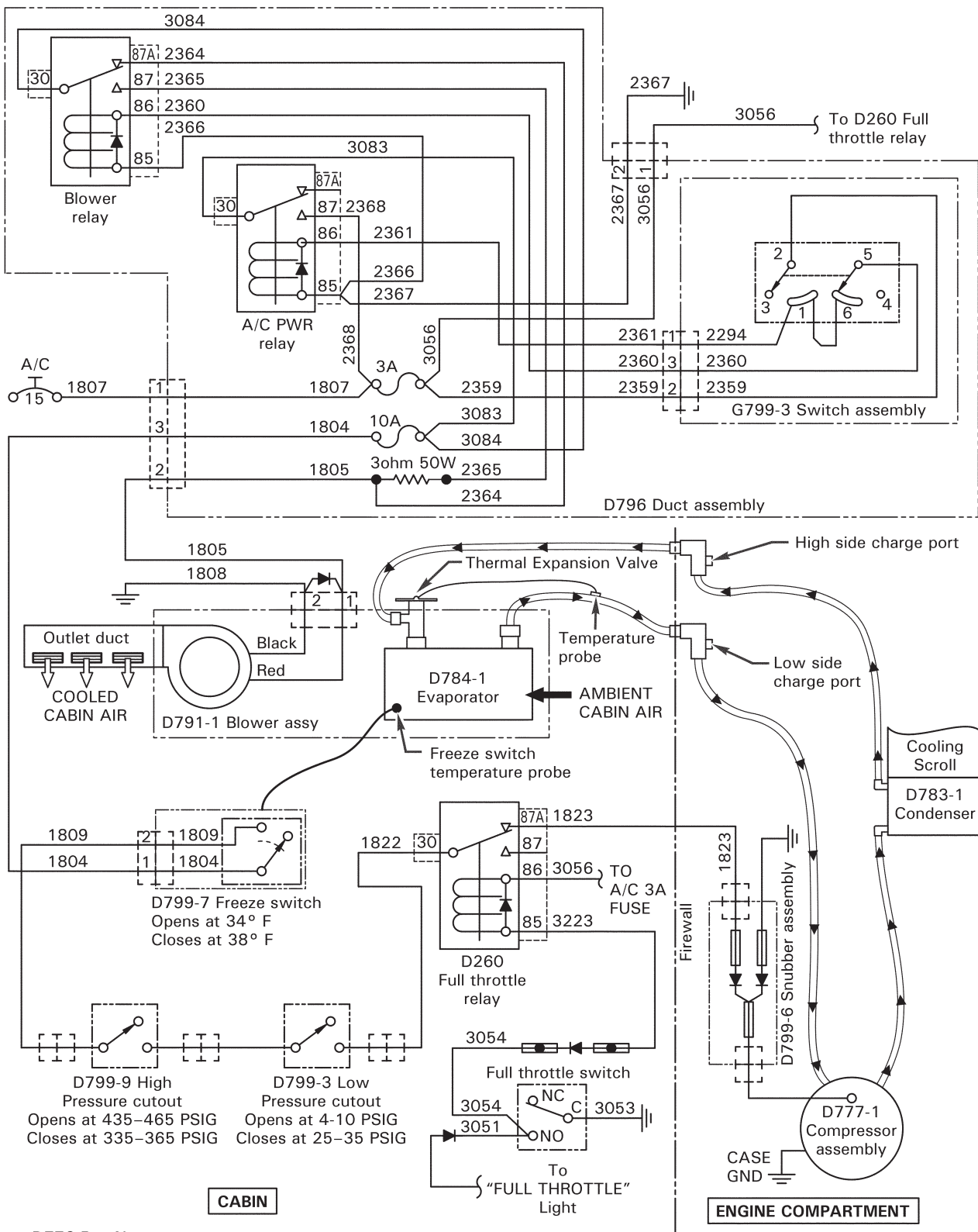

D776 Rev N

FIGURE 11-4 AIR CONDITIONING SYSTEM SCHEMATIC
R44 II S/Ns 14412 thru 29999
R44 Cadet S/Ns 30071 and subsequent

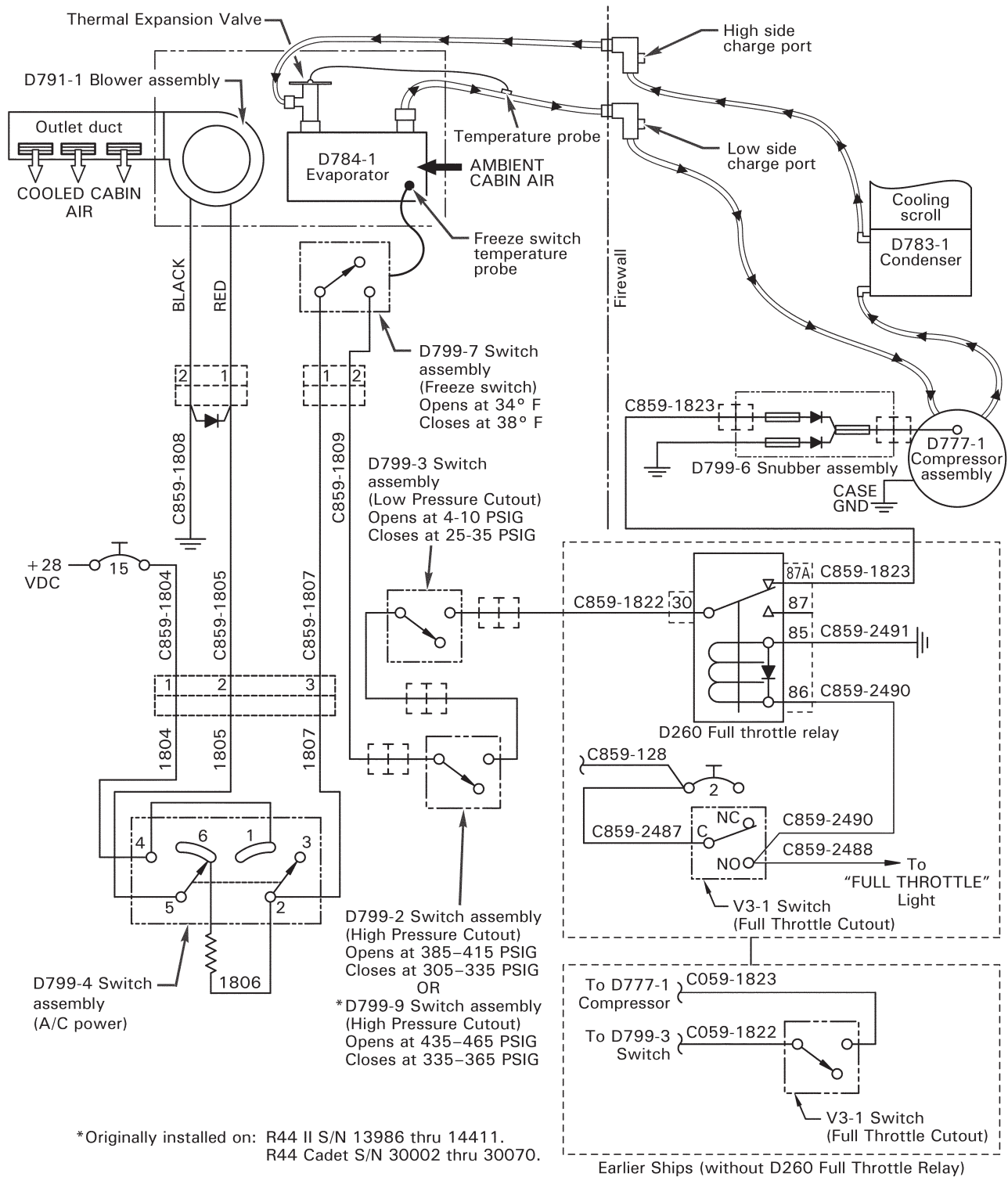

D776 Rev L

FIGURE 11-4A AIR CONDITIONING SYSTEM SCHEMATIC
R44 II S/Ns 10001 thru 14411
R44 Cadet S/Ns 30002 thru 30070

Intentionally Blank

11.310 System Troubleshooting

Two likely system difficulties are:

1. Failure to cool the air flowing through the evaporator and overhead duct.
2. Excessive condensate (water) in the evaporator box area when the system is operating.

Failure to cool is most likely caused by either refrigerant loss or interruption of the compressor clutch power supply (by one of the in-line switches or a wiring fault, see Figure 11-4 schematic). Excessive condensate is most often caused by an improperly assembled or blocked evaporator drain system. Both difficulties can usually be corrected with minimum effort and expense if careful troubleshooting is done prior to major component maintenance. A troubleshooting chart follows.

11.310 System Troubleshooting (cont'd)

PROBLEM	POSSIBLE CAUSE	TROUBLESHOOT/CORRECTIVE ACTION
Air is not cold	Low Refrigerant Charge/ Refrigerant Leak	Recover refrigerant per Section 11.321. System should operate normally on approximately 0.75 to 1.25 lb refrigerant. If less than 0.75 lb refrigerant is recovered, leak test per Section 11.323, repair leaks if any, and recharge per Section 11.322.
	Switch or Wiring Problem Interrupting Compressor Clutch Power	With aircraft not running, turn on Master switch and A/C switch on overhead duct (low or high setting ok). Have observer listen to and observe compressor clutch through left cowl door. Clutch should engage (click and snap against pulley) whenever A/C is switched on. Check wiring at freeze switch (behind D798-1 evaporator assembly), high and low pressure switches (behind left rear seatback), and full-throttle cutout switch (in control tunnel). Repair any damaged wiring or connectors. Verify correct rigging per Section 11.350. Check continuity through each switch. All switches should be closed with a properly charged system and aircraft at rest on ground. Replace any defective switch.
	Failed Compressor Belt	Inspect belt. Replace belt per Section 11.331 as required.
	Insufficient Condenser Airflow	Inspect condenser installation (left side of fan scroll). Verify no blockage and all seals in place. Remove blockage and/or repair seals to ensure airflow through core.
	Extreme Environmental Conditions	Extreme temperature and humidity may result in cooling effect less than a typical automobile. No corrective action available.
Excessive condensate around evaporator assembly and overhead duct	Blocked or Kinked Evaporator Drain Line	Verify system is draining normally. After several minutes ground run in humid conditions with A/C on, water should be seen draining from the drain tube. If water drainage is not observed, inspect drain line (see Section 11.343). Correct any damaged or kinked lines. Clean sediment trap as required. Verify proper function of check ball.
	Damaged Insulation	Verify evaporator assembly and duct insulation are installed correctly and undamaged (see R44 Parts Catalog). Correct any insulation deficiencies.
	Extreme Humidity	Some condensation is unavoidable in extreme humidity. Ensure all fresh air vents closed. Limit opening and closing cabin doors as much as practical to limit humidity entering cabin.

11.320 REFRIGERANT**11.321 Refrigerant Recovery**

If a leak or other service problem is encountered after system is charged with refrigerant, refrigerant must be recovered before work on system can proceed.

Automotive-style air conditioning service equipment is required to recover refrigerant. This equipment is available from many manufacturers in varying levels of automation and complexity. Minimum components include a vacuum pump, storage container, pressure/vacuum gauge, and appropriate lines and fittings. Ensure equipment is compatible with R134a refrigerant and technician is appropriately qualified before attempting refrigerant recovery.

Automotive-style high and low side system service ports are located on the vertical firewall inside the left-hand engine cowl door.

Connect service equipment to system service ports and recover refrigerant per equipment manufacturer's instructions.

11.322 Refrigerant Charge

Automotive-style air conditioning service equipment is required to charge system with refrigerant. This equipment is available from many manufacturers in varying levels of automation and complexity. Minimum components include a vacuum pump, pressure pump, refrigerant supply, scale to measure refrigerant charge, pressure/vacuum gauge, and appropriate lines and fittings. Service system only with R134a refrigerant, and ensure technician is appropriately qualified before attempting refrigerant charge.

CAUTION

Proper lubrication is required to minimize compressor wear. Verify compressor oil level per Section 11.333.5 before beginning charge procedure.

The R44 air conditioning system is not equipped with a traditional receiver-dryer. Ensure system is under full vacuum to eliminate all moisture before charging.

Automotive-style high and low side system service ports are located on the vertical firewall inside the left-hand engine cowl door.

Connect service equipment to system service ports, vacuum system, and charge with R134a refrigerant per equipment manufacturer's instructions. Correct charge is 1.25 lb (1 lb 4 oz, or 0.567 kg) refrigerant.

CAUTION

Do not overcharge system. If a slow leak is suspected, find and correct per Section 11.323 first, then use correct charge.

11.323 Leak Detection

Leaks may be detected using several techniques, depending on equipment available. Leak detection should not be attempted with the aircraft/system running. In addition to safety hazards, leaks are more difficult to detect with the varying pressures and temperatures of an operating system.

An empty system should hold full vacuum (27 to 29 in Hg vacuum at sea level) with no assistance from the vacuum pump for 20 minutes or more. If a vacuumed system creeps up in pressure, a leak may be present. Technician should be thoroughly familiar with vacuum equipment to ensure leak is in aircraft system and not in vacuum equipment or connections.

Leaks in a charged system may be detected using a mild soap and water solution applied to lines and fittings in suspected leak areas (bubbles indicate leaks) or using commercially available electronic refrigerant detectors. Follow detector manufacturer's instructions. Large leaks may be detected audibly if area is quiet or by formation of frost in area of leak.

NOTE

Frost does not necessarily indicate a leak. Normal system operation and/or charging procedures can cause frost to accumulate on some components.

NOTE

System pressure is not a reliable indicator of charge state or the presence of leaks. Because R134a is a liquid/vapor mixture with the system at rest, pressure will remain constant as more liquid vaporizes until majority of charge is lost.

Very small leaks can be detected by charging the system with helium gas. Helium molecules are smaller than R134a molecules and will leak more quickly. Charge system to 200 psi maximum. Use commercially available electronic helium detector or soap and water solution to locate leaks.

Leaks are most likely to occur at fittings and crimped transitions between hard line and flexible hose. Concentrate initial leak detection efforts in these areas.

11.330 COMPRESSOR

11.331 Compressor Belt Replacement

Compressor belt replacement is based on belt condition. Replace any belt exhibiting frayed edges, excessive cracking, heat damage, or rubber deterioration.

To replace belt, loosen NAS6604 bolt through D782-3 adjusting arm slot, and loosen all three NAS6606 bolts through compressor lugs. Rotate compressor up and inboard as required to disengage belt from either compressor or drive pulley, and remove belt.

CAUTION

Do not rotate compressor further than necessary to avoid damage to refrigerant lines and fittings. Do not use refrigerant lines or fittings for leverage; handle compressor body or lugs.

Slip new belt over both pulleys, and rotate compressor down and outboard to tension belt. Tension belt such that a 4.5 to 5.5 lb force applied mid-span produces 0.14 inch belt deflection. Tighten compressor mount and adjustment hardware.

11.332 Compressor Removal

1. Remove engine left cowling.
2. Disconnect and remove battery as required for compressor access.
3. Recover refrigerant per Section 11.321.
4. Disconnect compressor clutch wiring from airframe harness.
5. Disconnect refrigerant lines from compressor. Protect all open lines and fittings from contamination.
6. Remove belt from compressor drive pulley per Section 11.331.
7. Remove three compressor lug bolts loosened in step 6, and remove compressor.

11.333 Compressor Installation

1. Install compressor using three NAS6606 bolts at mount lugs and NAS6604 bolt at D782-3 adjusting arm slot. Refer to R44 Illustrated Parts Catalog for hardware stack up. Leave all hardware loose enough to rotate compressor.
2. Install compressor drive belt, tension per Section 11.331, and tighten mount and adjusting hardware.
3. Connect refrigerant lines to compressor. Torque low-pressure (large) fitting to 300 in.-lb. Torque high-pressure (small) fitting to 210 in.-lb.
4. Connect compressor clutch wiring to airframe harness.
5. Check and adjust compressor oil quantity as follows:

CAUTION

Recover refrigerant prior to checking oil level.

- a. Remove compressor oil fill cap (black hex-head cap on upper outboard surface of compressor body behind clutch and pulley).
 - b. Turn compressor shaft clockwise until clutch plate counterweight is positioned per Figure 11-5.
 - c. Insert Airpro P/N 90-3028 or equivalent dipstick per Figure 11-5, and take oil level reading.
 - d. Add A257-20 oil as required to bring dipstick reading to 8 to 10 notches. Approximately 2 to 3 ounces total oil is required for completely empty compressors. Compressors are typically shipped at least partially filled with oil.
 - e. Reinstall fill cap. Torque to 156 in.-lb.
6. Perform vacuum or helium leak check per Section 11.323.
 7. Charge system with refrigerant per Section 11.322.
 8. Install and connect battery (if removed).
 9. Install engine left cowling.

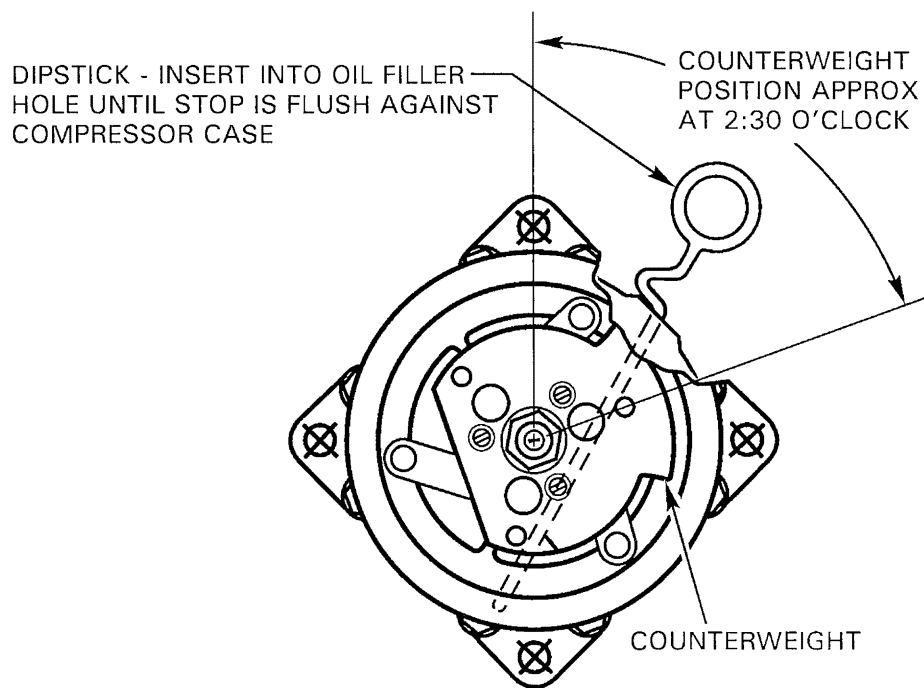

FIGURE 11-5 COMPRESSOR OIL FILL

11.340 EVAPORATOR ASSEMBLY

11.341 Evaporator Assembly Removal

1. Recover refrigerant per Section 11.321.
2. Remove overhead duct as follows:
 - a. Remove screw aft of rotor brake knob.
 - b. Slide duct forward and down to disengage tabs from evaporator box and windshield frame.
 - c. Push rotor brake knob through slot in duct.
 - d. Disconnect electrical connector.
 - e. Remove duct.
3. Remove screws (4 each side) securing headset jack boxes to evaporator assembly.

NOTE

Two different length screws and two different length spacers are used to mate headset jack boxes to evaporator. Use caution to retain spacers during disassembly and note hardware arrangement for re-assembly.

NOTE

The entire decorative (headliner) cover is secured to the evaporator box via hook and loop fastening material and may be removed if desired. It is necessary to remove the headset hangers in order to remove the cover. Refer to R44 Illustrated Parts Catalog for details.

4. Remove trim securing headliner between seats, and remove left rear seat back.
5. Remove and discard safety wire, and remove drain tube from drain fitting at base of evaporator box (right side).
6. Disconnect refrigerant lines at vertical connection nuts near upper inboard seat back corner.
7. Push back headliner as required, and remove 6 screws securing evaporator box flanges to aft cabin bulkhead. Tilt top of evaporator box forward and lift up and out.

11.342 Evaporator Assembly Installation

1. Secure evaporator box to aft cabin bulkhead using 6 screws through box flanges.
2. Verify O-rings are clean and undamaged, and connect refrigerant line connection nuts. Torque insulated line to 210 in.-lb and uninsulated line to 150 in.-lb.
3. Connect drain tube to evaporator box drain fitting and secure using 0.032 in diameter safety wire.
4. Secure headset jack boxes to evaporator assembly. Use screw and spacer arrangement retained from Section 11.341 or refer to R44 Illustrated Parts Catalog for hardware details.
5. Install overhead duct as follows:
 - a. Position duct approximately, feed rotor brake knob through slot in duct, and connect electrical connector.
 - b. Slide duct up and aft such that tabs engage evaporator box fan opening and windshield frame.
 - c. Install screw aft of rotor brake knob.
6. Verify no leaks (refer to Section 11.323 as required). Charge system per Section 11.322.
7. Install left rear seat back, and secure headliner between seat backs using trim.

11.343 Evaporator Drain System

The evaporator drain system, shown schematically in Figure 11-6, is designed to prevent condensate from backing up in the evaporator box and leaking into the passenger compartment. All components are necessary for proper drainage. Blockage or kinking of a drain line may result in water damage to the cabin interior near the evaporator box.

The flexible tube drains condensate to the tee located behind the right rear seat back. At tee, a sediment-tube extends several inches down to a plug. The sediment-tube is designed to allow contamination to settle out without clogging the main drain system. Inspect tube periodically. Remove plug and clean out tube if sediment build-up nears tee fitting.

Just above tee fitting is a ball retained in upper flex tube. Normally a small amount of water is retained in the loop formed by drain tube and tee fitting. If the system is dry, the ball seats against the tee and prevents the evaporator fan from drawing air up through the drain system until water fills this area.

The hard drain tube runs along the aft, inboard corner of right-rear baggage compartment and out the belly. Normal system operation in humid conditions should result in condensation dripping from the tube. In extremely dry conditions there may be little or no condensation. Periodically inspect evaporator drain assembly to verify it has not been damaged or dislodged.

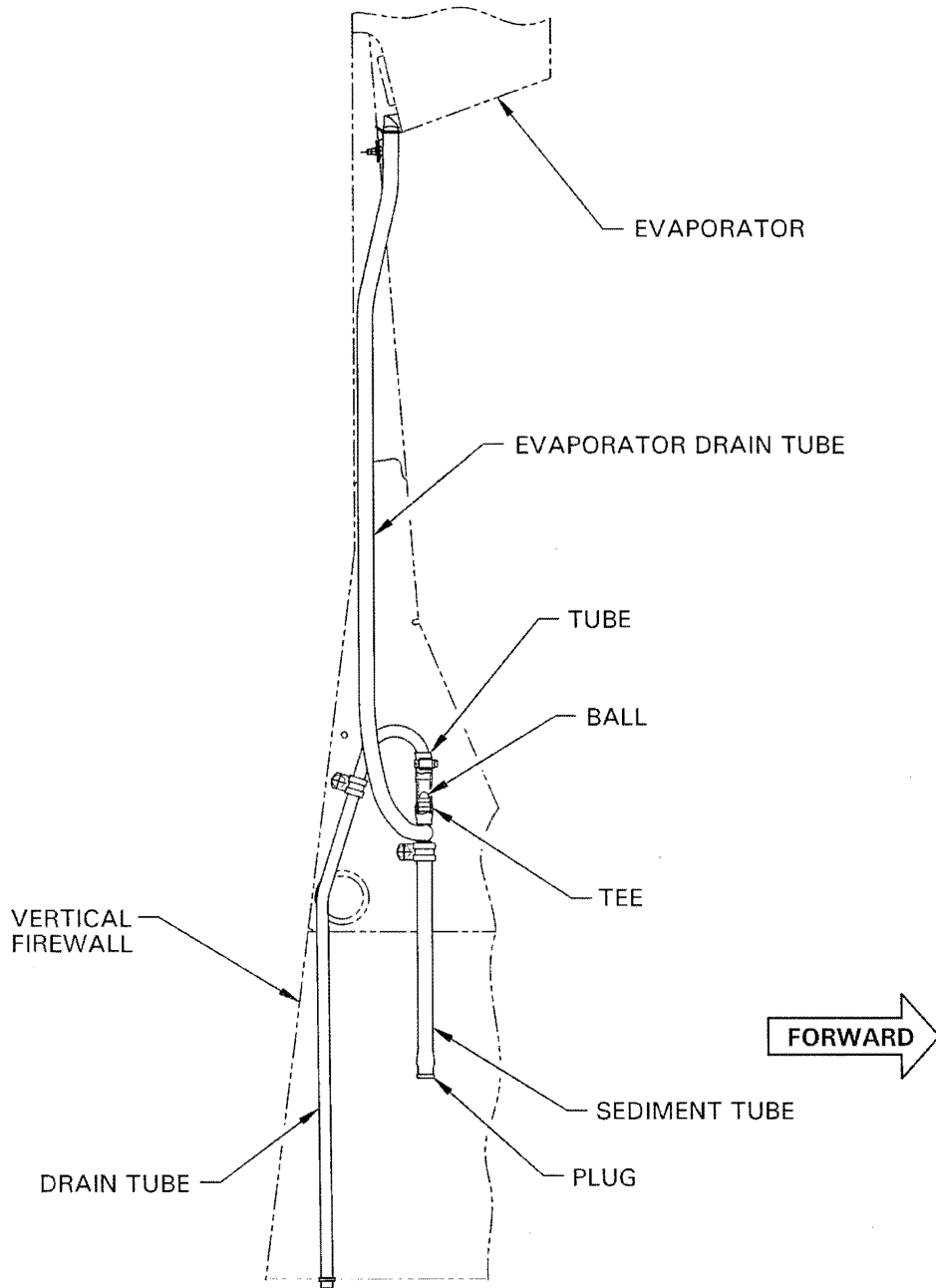
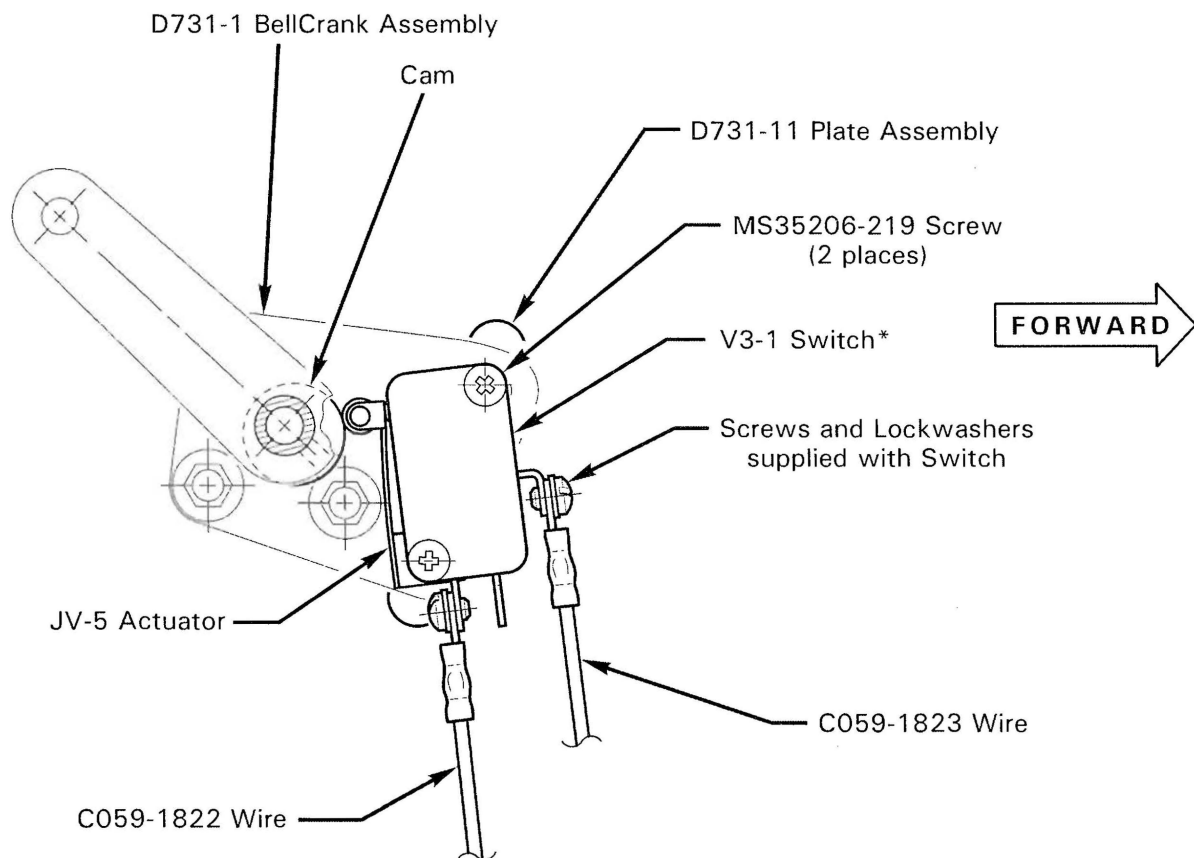

FIGURE 11-6 EVAPORATOR DRAIN SYSTEM

11.350 Full Throttle Cut-Out Switch Rigging

A full-throttle cut-out switch is designed to disengage the compressor clutch approximately 1 inch MAP below full throttle. This guarantees that air conditioning operation does not affect aircraft performance at altitude. Full throttle cut-out is controlled via a microswitch located near the bellcrank assembly at the aft end of the throttle push-pull tube in the main control tunnel. The switch is normally closed (allows current flow to the compressor) when its button is not depressed. A cam on the bellcrank assembly depresses the button and opens the switch near full throttle.

Adjust switch so button is depressed by cam when throttle arm at fuel control is 0.15 to 0.20 inch away from full-open throttle stop.



* Adjust position of V3-1 switch so that switch opens when fuel control throttle arm is 0.15 - 0.20 off full throttle stop.

**FIGURE 11-7 AIR CONDITIONING CUTOFF SWITCH
(View looking outboard from centerline)**

11.400 DRIVE CARTRIDGE11.410 Drive Cartridge Seal Removal

1. Remove engine left cowling.
2. Disconnect and remove battery as required for access.
3. Loosen belt tension and remove belt from pulley.
4. Refer to Figure 11-7. Remove B330-19 palnut and MS21042L6 nut.
5. Remove pulley from shaft to expose A966-5 seal and woodruff key.
6. Remove seal using appropriate tool being careful not to damage housing. Do not remove shims under seal.

11.420 Drive Cartridge Seal Installation

1. Ensure seal recess area is clean and free of debris.
2. Ensure shims are in place, and install A966-5 seal flush with the housing.
3. Install woodruff key and pulley on shaft.
4. Install MS21042L6 nut and special torque per Section 1.330. Install B330-19 palnut and standard torque per Section 1.320. Apply B270-22 protectorant to exposed surfaces of shaft.
5. Install compressor drive belt, tension per Section 11.331, and adjusting hardware.

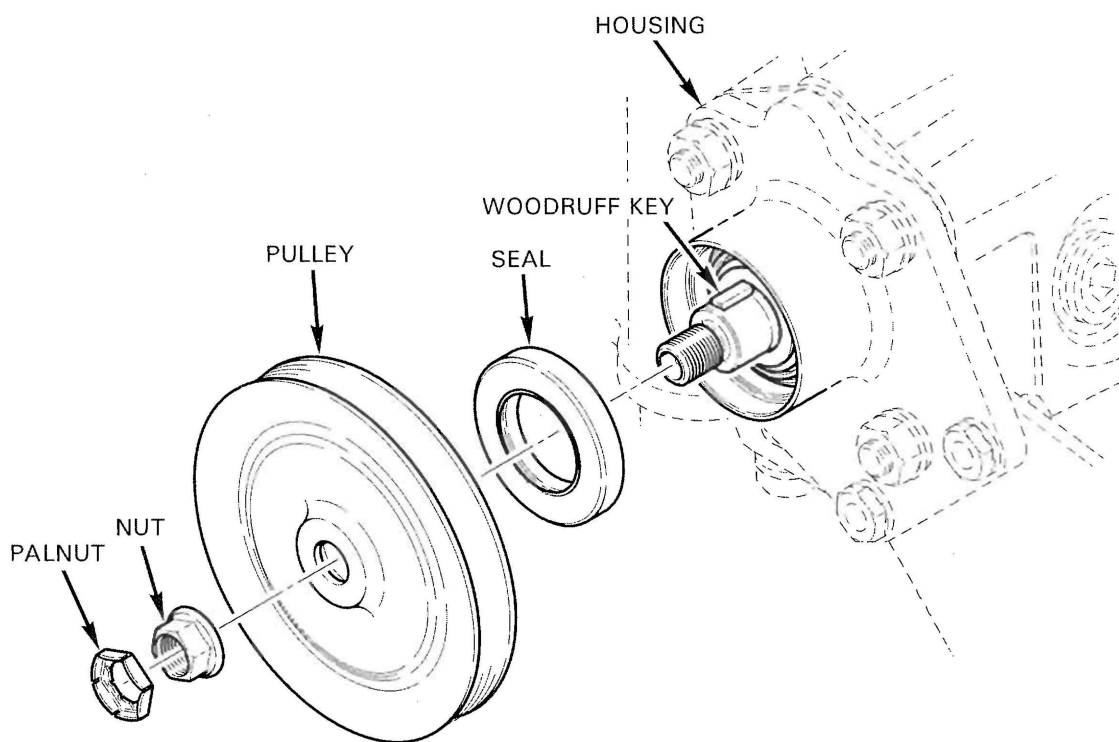

FIGURE 11-7 CARTRIDGE ASSEMBLY - COMPRESSOR DRIVE

CHAPTER 12**FUEL SYSTEM**

<u>Section</u>	<u>Title</u>	<u>Page</u>
12-00	Description	12.1
12-10	Main Fuel Tank	12.5
12-11	Main Tank Bladder Replacement	12.8
12-12	Main Tank Replacement	12.11
12-13	Fuel Cap(s)	12.12A
12-20	Aux Fuel Tank	12.13
12-21	Aux Tank Bladder Replacement	12.15
12-22	Aux Tank Replacement	12.17
12-30	Fuel Vents	12.18
12-31	Roll-Over Valve Assemblies	12.18
12-40	Drain Valves	12.19
12-50	Fuel Quantity	12.20
12-51	Fuel Quantity Senders	12.20
12-52	Fuel Quantity Sender Check	12.21
12-53	Fuel Quantity Indication Check	12.22
12-54	Low-Fuel Switch Assembly	12.23
12-60	Gascolator Assembly and (R44 II) Aux Fuel Pump Installation	12.25
12-70	Minimum Fuel Flow Check	12.31
12-80	R44 II Troubleshooting	12.32
12-81	Flow Divider Internal Leakage Check	12.32
12-82	Injection Nozzle Comparative Flow Check	12.33
12-83	Pressure Relief Valve Leakage Check	12.33

Intentionally Blank

CHAPTER 12

FUEL SYSTEM

12-00 Description

NOTE

Per R44 Service Bulletin SB-78B, fuel tanks without bladders should no longer be in service.

The fuel system includes main and auxiliary tanks, a shutoff valve control located between the front seats, and a strainer (gascolator). The fuel tanks have flexible bladders in aluminum enclosures. Fuel tank air vents are located inside the mast fairing.

The R44 fuel system is a gravity-flow (no fuel pumps) system; the R44 II fuel system is a pressurized fuel system that includes an engine-driven pump, an auxiliary (electric) fuel pump, and a fuel return line which allows pump supply in excess of engine demand to return to the fuel tanks.

The R44 II auxiliary pump primes the engine for starting and runs in flight to provide fuel pump redundancy. The engine will function normally with either the engine-driven or auxiliary (electric) pump operating. The ignition switch prime (momentary) position operates the auxiliary fuel pump for priming prior to engine start. After start, the pump runs continuously as long as the engine has oil pressure and the clutch switch is in the engage position.

The R44 II has a pressure switch on the gascolator which illuminates the fuel filter caution light if the strainer becomes contaminated. Continued operation with an illuminated filter caution light may result in fuel starvation. A pressure switch downstream of the auxiliary fuel pump illuminates the aux fuel pump caution light if auxiliary pump output pressure is low. When the clutch switch is disengaged, the auxiliary pump is off and the aux fuel pump caution light should be illuminated. Proper mechanical fuel pump function is indicated by normal engine operation after engine start prior to clutch switch engagement and before shutdown while clutch switch is disengaged.

The R44 and R44 II have plunger-style drain valves at the gascolator and at each fuel tank sump. The gascolator is located on the lower right side of the firewall and is drained by pushing up on the plastic tube which extends below the belly. Valves for both tanks are located inside the right cowl door below the auxiliary tank. Fuel samples are taken by extending the plastic tubes clear of the aircraft and pushing on the plungers. On newer helicopters, a glass tube stowed inside the upper, aft cowl door is provided which may be used to catch the fuel samples. Fuel should be sampled from all three locations prior to the first flight of the day and after refueling to verify no contamination and correct grade.

12-00 Description (continued)

The fuel gages are electrically operated by float-type transmitters in the tanks. When the gages read E the tanks are empty except for a small quantity of unusable fuel. The low fuel caution light is actuated by a separate electric sender located on the bottom of the main tank.

The auxiliary tank is interconnected with the main tank and is located somewhat higher so it will become empty first while fuel still remains in the main tank. The fuel shutoff valve controls flow from both tanks to the engine.

Intentionally Blank

FIGURE 12-1 R44 FUEL SYSTEM
(LYCOMING O-540 ENGINE; CARBURETED)

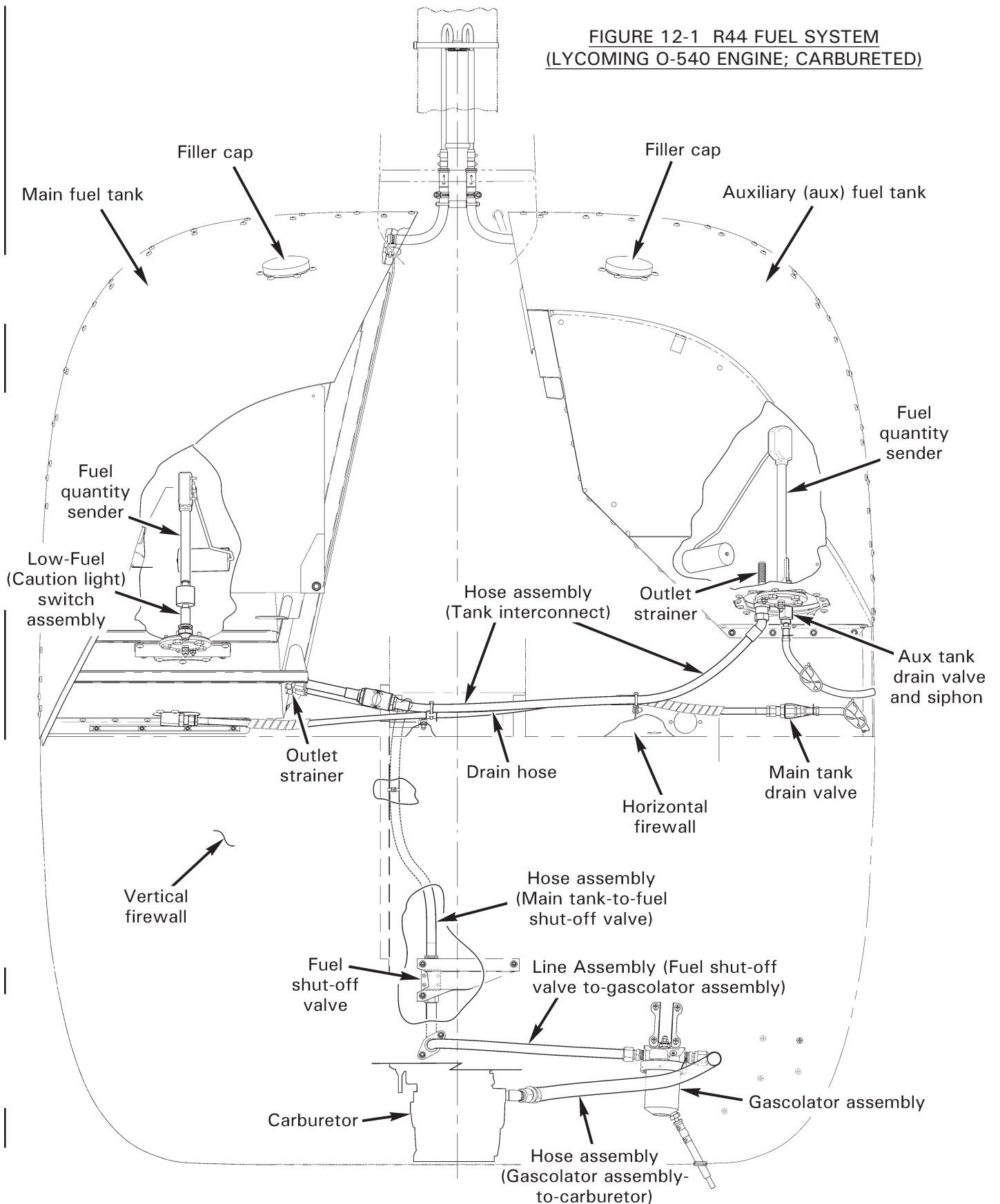

12-10 Main Fuel Tank**CAUTION**

Flexible hoses kink easily; handle with care.

CAUTION

Temporarily cap fuel fittings when opened.

WARNING

Fuel vapors are explosive. Do not use electric tools in vicinity of an opened fuel system.

A. Removal

1. Defuel helicopter per § 1.150.
2. Remove mast fairing. Open access doors, disconnect ELT antenna & ground wire at connectors if ELT is installed, and remove tailcone fairing. Remove C347 channel assembly, angles, and panel.
3. Remove aft left backrest assembly. Remove left cowling assembly.
4. Loosen clamps securing vent tube(s) to C010-6 main tank assembly and pull tube(s) off tank.
5. Cut & discard ty-raps as required and disconnect fuel quantity sender and low-fuel switch assembly wiring from airframe harness at connectors.
6. Disconnect D205-38 (or D205-28; tank-to-shut-off valve) and C595-2/-3 (or D205-29; tank interconnect) hose assemblies from tank.
7. Cut & discard ty-raps attaching D205-30 (drain) hose assembly to horizontal firewall clamp and doubler, then disconnect hose from drain valve connector. Cap fittings.
8. Above aft left seat, gently lift foam from cabin bulkhead and remove four screws securing tank to bulkhead.
9. At tank aft panel, remove three screws securing tank to the intermediate bulkhead, and two bolts securing tank aft panel between horizontal firewall and upper frame.
10. Remove perimeter screws securing tank to cabin bulkhead and horizontal firewall. Remove tank, with attached D205-30 hose assembly. Cap fittings.

FIGURE 12-2 R44 II FUEL SYSTEM
(LYCOMING IO-540 ENGINE; FUEL INJECTED)

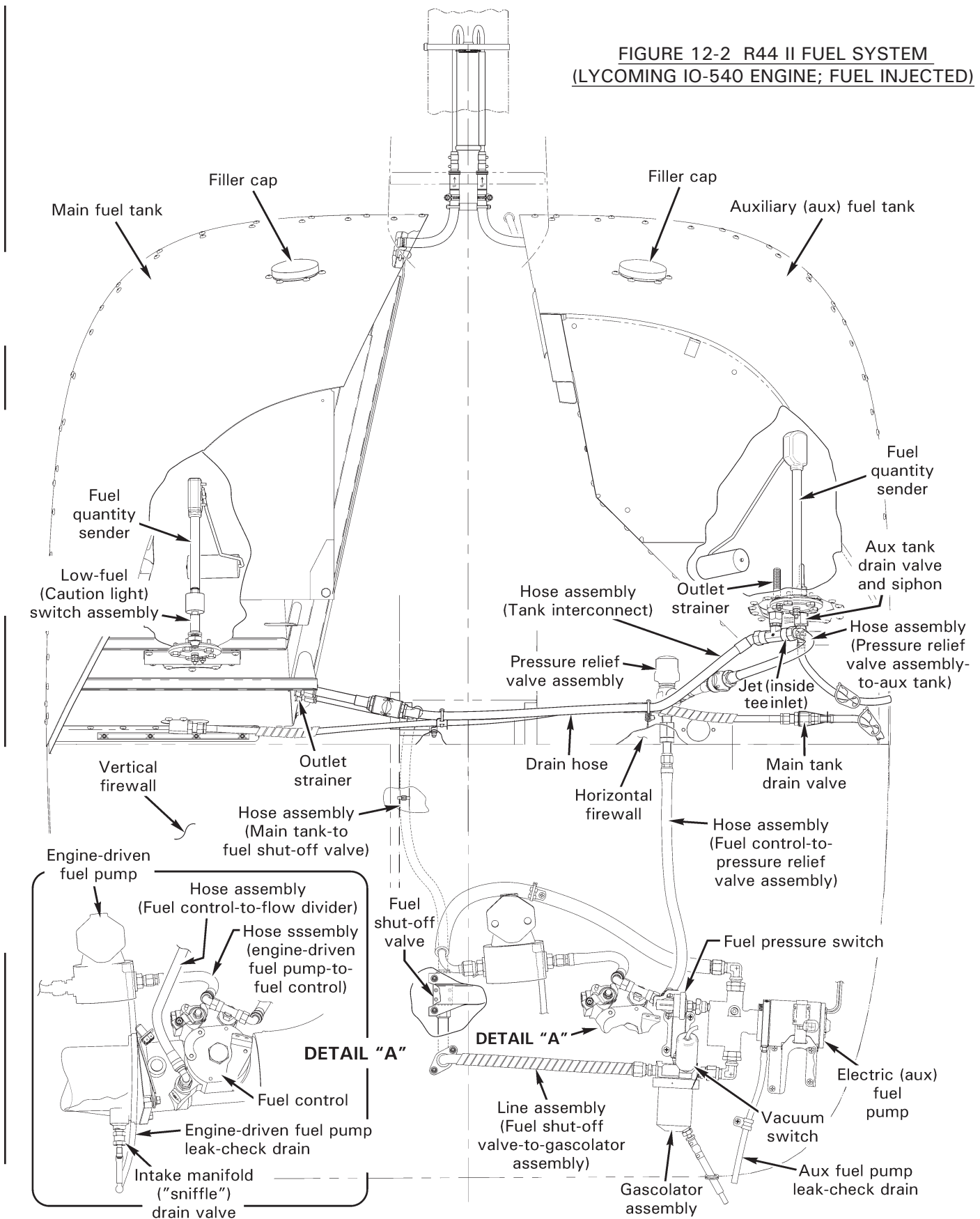

12-10 Main Fuel Tank (continued)**B. Installation**

1. Connect D205-30 (drain) hose assembly to main tank drain union; using backup wrench on tank union, special torque hose nut per § 23-33 and torque stripe per Figure 2-1. Position C010-6 main tank assembly in helicopter, routing D205-30 (drain) hose assembly atop D255-5 support assembly (or thru "cut away" in horizontal firewall doubler; verify hose is not pinched). Install perimeter screws securing tank to cabin bulkhead and horizontal firewall.
2. At tank aft panel, install hardware securing tank aft panel between horizontal firewall and upper frame. Standard torque nuts per § 23-32 and torque stripe per Figure 2-1.
3. Install screws securing tank aft panel to the intermediate bulkhead.
4. Above aft left seat, gently lift foam from cabin bulkhead and install screws securing tank to bulkhead.
5. Remove caps. Connect D205-38 (or D205-28; tank-to-shut-off valve) hose assembly to tank forward fitting. Connect C595-2/-3 (or D205-29; tank interconnect) hose assembly to tank aft fitting. Using backup wrench on tank fittings, special torque hose nuts per § 23-33 and torque stripe per Figure 2-1.
6.
 - a. Install ty-rap around D205-30 hose assembly through D255-5 support assembly or horizontal firewall clamp; install ty-rap around trim through horizontal firewall doubler flange and install ty-rap around hose assembly through doubler ty-rap. Cinch ty-raps until snug without over-tightening, and trim tips flush with heads.
 - b. Install ty-rap around C595-2/-3 hose assembly through D255-5 support assembly; install ty-rap around trim through horizontal firewall doubler flange and install ty-rap around hose assembly through doubler ty-rap. Cinch ty-raps until snug without over-tightening, and trim tips flush with heads.
7. Connect fuel quantity sender and low-fuel switch assembly wiring to airframe harness at connectors.
8. Connect vent tube(s) to tank and tighten clamps until snug. Verify security.
9. Perform fuel quantity indication check per § 12-53. Verify no leaks.
10. Install aft left backrest assembly and left cowling assembly.
11. Install C347 channel assembly, angles, and panel. Install tailcone fairing, connect ELT antenna & ground wire at connectors if ELT is installed, and close access doors. Install mast fairing.
12. Perform pitot-static leak check per § 13-10 as required.
13. Inspect fuel cap per § 12-13 Part A.

12-11 Main Tank Bladder Replacement**NOTE**

During disassembly, progressively tape bladder openings to protect interior from foreign object contamination. During assembly, progressively remove protective tape.

CAUTION

D028-1 or -3 bladder assembly temperature should be above 65°F before removing, installing, or flexing bladder.

1. Remove main fuel tank per § 12-10.
2. Remove hardware securing D247-1 bulkhead assembly and three angles to tank and remove angles. Detach hook-and-loop tape and remove bulkhead.
3. Remove fuel quantity sender per § 12-51.
4. Remove screws securing D250-1 cover assembly to D028-1 or -3 bladder assembly and tank; carefully remove cover, with low-fuel switch assembly attached. Remove and discard packing.
5. Disconnect D205-30 (drain) hose assembly from union and cap hose fitting. Remove union and discard packing. Remove two screws securing bladder to tank.
6. Remove B254-3 strainer assembly and (tank interconnect fitting) union and discard packings. Remove two screws securing bladder to tank.
7. At vents, remove screw securing bladder to tank.
8. Remove fuel cap. Remove screws securing bladder to tank.
9. Detach hook and loop tape and carefully remove bladder.
10. Carefully insert new D028-1 or -3 bladder assembly inside main tank assembly. Ensure bladder is free of wrinkles across lower surface and properly located before joining hook & loop fastener. Bladder may be pressurized with air to 1 psi max to assist installation. Align bladder and tank fastener holes and press hook-and-loop tape together.
11. Install screws securing bladder to tank near fuel cap. Install fuel cap.
12. At vents, apply A257-9 anti-seize to threads and install screw securing bladder to tank.
13. Apply A257-9 anti-seize to threads and install two screws securing bladder to tank near tank interconnect and tank-to-shut-off valve hose connections. Lubricate new packings with A257-6 grease and install packings on B254-3 strainer assembly and on (tank interconnect fitting) union. Apply A257-9 anti-seize to threads and install strainer assembly into forward fitting; special torque strainer per § 23-33, and torque stripe per Figure 2-1. Apply A257-9 anti-seize to threads and install union into aft fitting; special torque union per § 23-33, and torque stripe per Figure 2-1.

12-11 Main Tank Bladder Replacement (continued)

14. Apply A257-9 anti-seize to threads and install two screws securing bladder to tank near drain hose connection. Lubricate new packing with A257-6 grease and install packing on (drain hose fitting) union. Apply A257-9 anti-seize to threads and install union; special torque union per § 23-33, and torque stripe per Figure 2-1. Remove cap and connect drain hose to union; using backup wrench, special torque hose nut per § 23-33, and torque stripe per Figure 2-1.
15. Lubricate new packing with A257-6 grease and install packing in bladder groove in opening at bottom of tank. Carefully insert cover assembly into bladder, with attached low-fuel switch assembly aft. Apply A257-9 anti-seize to threads and install screws securing cover to bladder and tank.
16. Install fuel quantity sender per § 12-51.
17. Align bulkhead and tank fastener holes. Install hardware securing bulkhead and angles to tank.
18. Pressure check assembled fuel tank by plugging vents and fittings and pressurizing bladder to no more than 1 psi. Check for leaks with a mild soap and water solution applied to all seams.
19. Install main fuel tank per § 12-10.

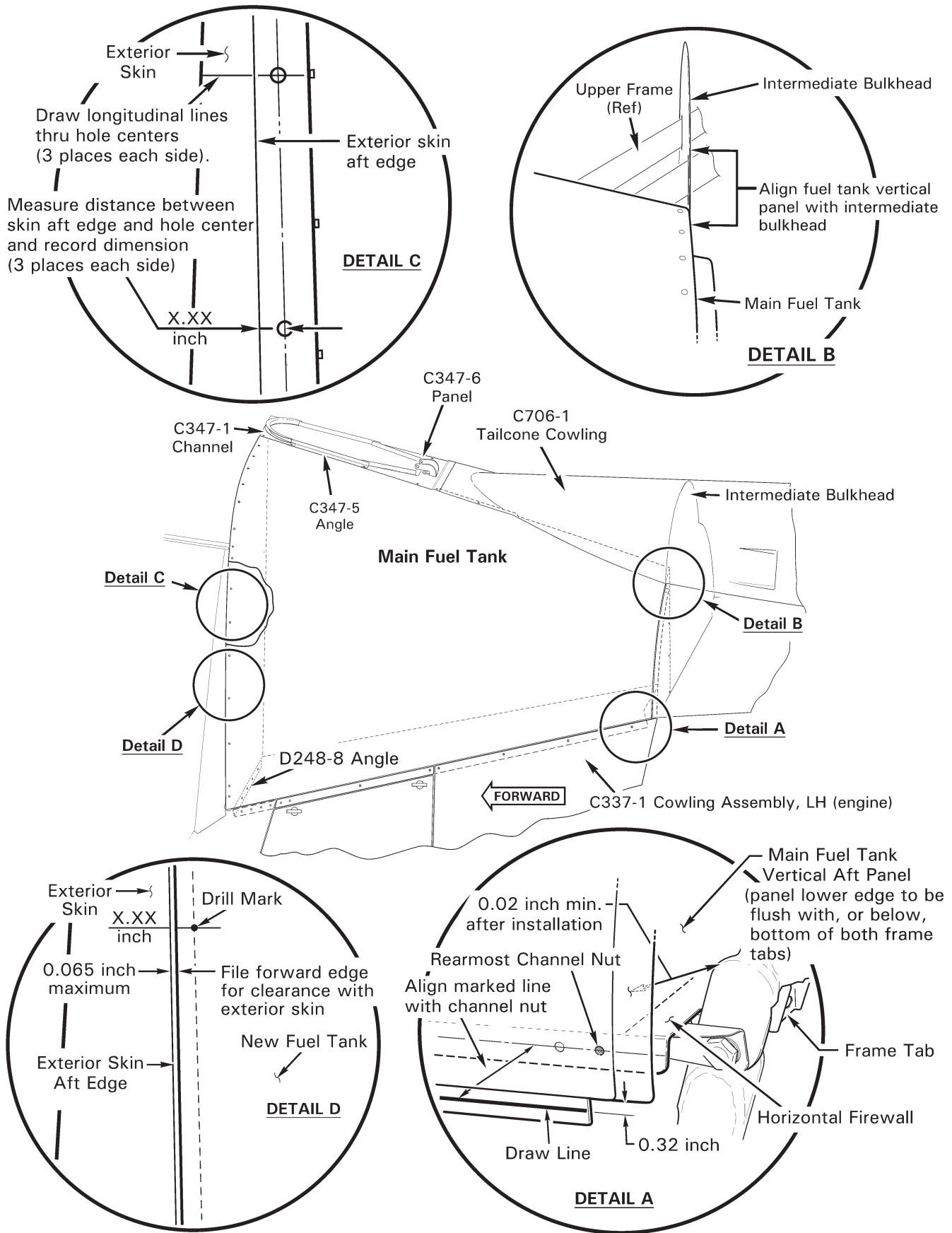

FIGURE 12-3 MAIN TANK REPLACEMENT

12-12 Main Tank Replacement

1. Remove main fuel tank per § 12-10.
2. Refer to Figure 12-3, Detail C. Draw longitudinal lines from center of three bulkhead channel nut holes onto exterior skins. Measure and record distances as shown.
3. On new C010-6 main tank assembly, loosen screws securing D248-8 angle to tank and slide angle to forward-most position. Tighten screws.
4. Refer to Figure 12-3, Detail A. Mark tank bottom flange with a line 0.32 inch below and parallel to tank skin.
5. Position tank in helicopter. Verify forward portion of tank flange is between exterior skin and horizontal firewall flange. Verify tank vertical panel is between upper frame tabs and firewall flange; panel edge must be flush or below frame tab bottom edge.
6. Align marked line with rearmost channel nut on horizontal firewall flange per Figure 12-3, Detail A. Align tank vertical panel with intermediate bulkhead per Detail C. Secure tank position by clamping panel to frame tabs.
7. Install aft cowling assembly. Install left cowling assembly, but do not install top row of screws. Adjust tank position as required for approximately 0.020 inch gap between tank skin and left cowling.
8. Refer to Figure 12-3, Detail D. Estimate material to be removed for fitting tank forward edge with cabin exterior skin aft edge; file or cut tank to create a gap of no more than 0.065 inch between tank and skin. Deburr trimmed edge with 220-grit or finer wet-or-dry aluminum oxide abrasive paper.
9. Conversion coat trimmed edge per § 23-51. Apply epoxy primer (ref. § 23-75) to trimmed edge.
10. From inside cabin, begin at the lowest nutplate and drill a #30 pilot hole through tank skin (using existing nutplate as drill guide), and install cleco. Moving upward, repeat step for remaining nutplates.
11. Transfer longitudinal lines and recorded distances from exterior skin to tank, and lay out three drill marks. Using a drill stop, enlarge pilot holes to 0.170-inch diameter.
12. From inside cabin, gently lift foam and match-drill 0.170-inch holes in D248-8 angle through holes in C259-1 bulkhead.

CAUTION

Protect drive belts from drilling debris.

13. Match-drill 0.170-inch holes in tank vertical panel through holes in intermediate bulkhead. Match-drill 0.250-inch holes in panel through upper frame tab holes; temporarily install bolts.

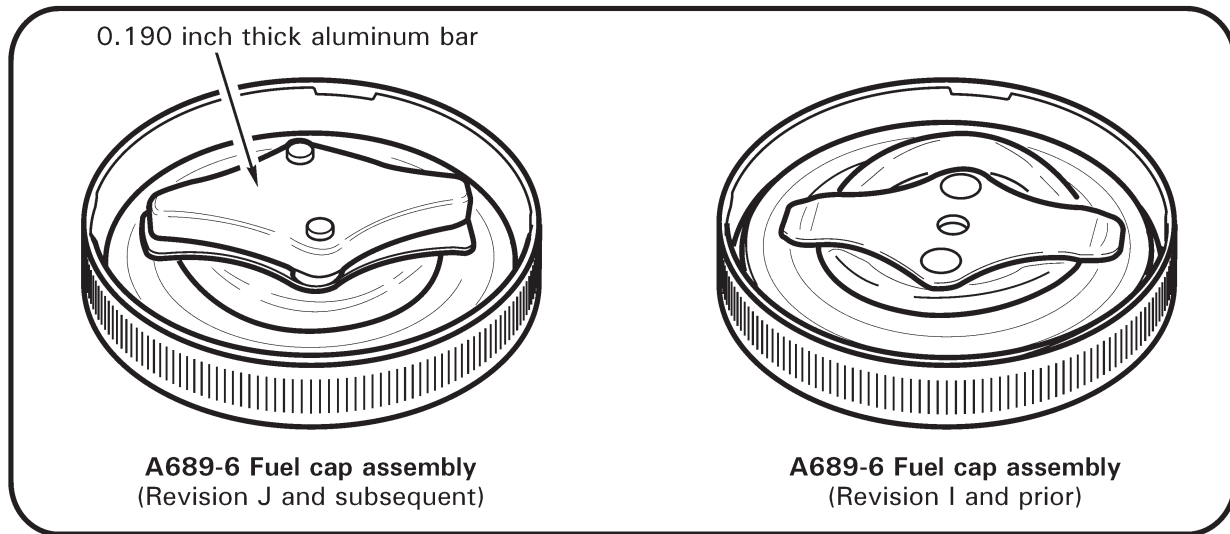

FIGURE 12-3A A689-6 FUEL CAP REVISIONS

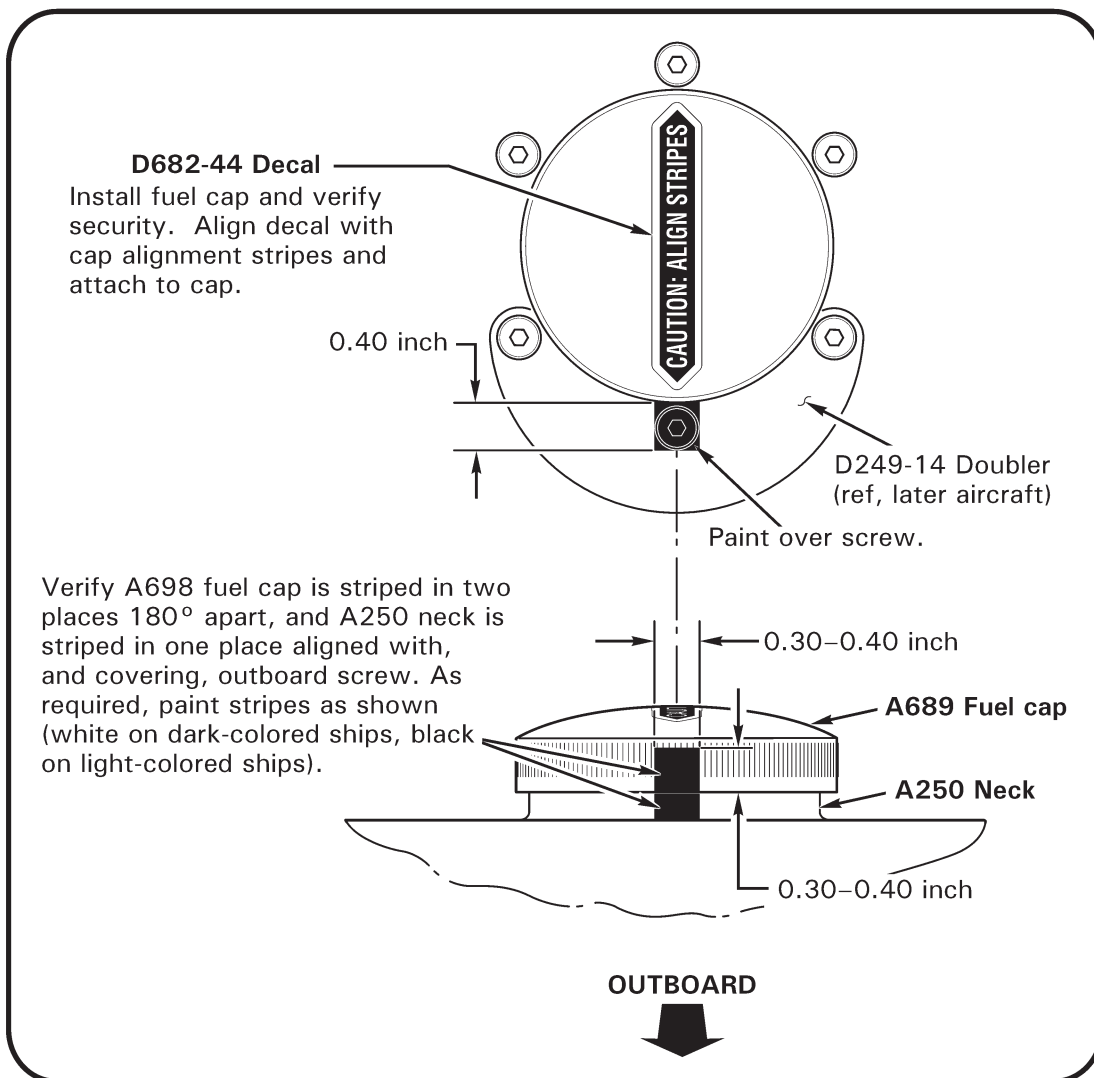

FIGURE 12-3B FUEL CAP ALIGNMENT STRIPES

12-12 Main Tank Replacement (continued)

14. Using a drill stop, progressively match-drill and cleco 0.170-inch holes in tank flange, on marked line, through left cowling holes.
15. Cleco C347-1 channel to cabin. Match-drill 0.170-inch holes in tank inboard flanges through remaining holes in channel.
16. Clean up debris. Install main fuel tank per § 12-10.
17. Paint fuel cap alignment stripes and apply decal per § 12-13 Part B.

12-13 Fuel Cap**A. Inspection**

1. Remove A689-6 fuel cap and verify cap is revision J or subsequent per Figure 12-3A.
2. Inspect condition of cap and gasket. Install fuel cap and verify security. Replace gasket and/or cap if cap is not snug when tightened or visual inspection is not satisfactory.
3. Verify fuel cap is striped in two places 180° apart, and fuel tank's A250 neck is striped in one place facing outboard. If cap or neck is not striped, or if stripes have deteriorated, paint stripes per Part B.
4. Verify cap decal is legible and properly installed, and stripes on cap and tank align when cap is fully closed.

B. Fuel Cap Alignment Stripes and Decal

1. As required, apply topcoat to fuel cap per § 23-60 using approved paint (ref. § 23-77).
2. Refer to Figure 12-3B. As required, paint fuel tank's A250 neck stripe (in one place aligned with, & covering, outboard screw) and/or fuel cap stripes in two places 180° apart aligned with fuel neck stripe per the following:
 - a. Clean surfaces to be painted using a lint-free, clean cloth dampened with acetone. Allow surfaces to dry.
 - b. Apply D257-7 black (Imron AF400/AF700) for light-colored ships or D257-5 white (Imron AF400/AF700) for dark-colored ships, mixed in accordance with paint manufacturer's recommendations, to surfaces.
3. Attach D682-44 decal to A689 fuel cap as shown.

Intentionally Blank

12-20 Aux Fuel Tank**CAUTION**

Flexible hoses kink easily; handle with care.

CAUTION

Temporarily cap fuel fittings when opened.

WARNING

Fuel vapors are explosive. Do not use electric tools in vicinity of an opened fuel system.

A. Removal

1. Defuel helicopter per § 1.150.
2. Open right side of mast fairing. Open access doors, disconnect ELT antenna & ground wire at connectors if ELT is installed, and remove tailcone fairing. Remove C347 channel assembly, angles, and panel. Remove D042-5 door assembly.
3. Remove aft-right backrest assembly.
4. Loosen clamp(s) securing vent tubes to D043-5 aux tank assembly and pull tubes off tank.
5. Cut & discard ty-raps as required and disconnect fuel quantity sender wiring from airframe harness at connectors.
6. Remove hardware securing rotor brake cable clamp to tank channel. Remove screws securing B157-1 mount to channel if screws have nutplates, or remove hardware securing MS24566-1B pulley to B157-1 mount.
7. a. R44: Disconnect hose assembly from B254-3 fitting (or tank elbow). Cap fittings.
b. R44 II: Disconnect hose assemblies from tank tee. Remove D453-5 jet (used with C595-4 hose assembly) or D453-2 jet (used with D205-31 hose assembly) from tee if desired. Cap fittings.
8. Above aft right seat, gently lift foam from bulkhead and remove fasteners securing tank to bulkhead.
9. Remove aft bolt securing tank channel to upper frame.
10. Remove perimeter screws securing tank to bulkhead. Remove tank.

12-20 Aux Fuel Tank (continued)**B. Installation**

1. Position D043-5 aux tank assembly in helicopter. Install aft bolt securing tank channel to upper frame. Standard torque bolt per § 23-32 and torque stripe per Figure 2-1.
2. Install perimeter screws securing tank to bulkhead.
3. Above aft right seat, gently lift foam from bulkhead and install fasteners securing tank to bulkhead.
4. a. R44: Remove caps. Connect hose assembly to B254-3 fitting (or tank elbow). Special torque hose nuts per § 23-33 and torque stripe per Figure 2-1.
b. R44 II: Remove caps. Verify tank tee is aligned with D321-1 valve assembly within 5°. Install if removed, or verify the proper installation of, D453-5 jet (used with C595-4 hose assembly) or D453-2 jet (used with D205-31 hose assembly) in tee inlet (outboard). Connect hose assemblies to tee. Verify D205-31 hose assembly elbow is horizontal within 5°. Special torque hose nuts per § 23-33 and torque stripe per Figure 2-1.
5. Install screws securing B157-1 mount to channel if screws have nutplates, or install hardware securing MS24566-1B pulley to B157-1 mount. Install hardware securing rotor brake cable clamp to tank channel. Verify security.
6. Connect fuel quantity sender wiring to airframe harness at connectors.
7. Connect vent tube(s) to tank and tighten clamps until snug. Verify security.
8. Perform fuel quantity indication check per § 12-53. Verify no leaks.
9. Install aft-right backrest assembly.
10. Install D042-5 door assembly. Install C347 channel assembly, angles, and panel. Install tailcone fairing, connect ELT antenna ground wire at connector if ELT is installed, and close access doors. Close right side of mast fairing.
11. Inspect fuel cap per § 12-13 Part A.

12-21 Aux Tank Bladder Replacement**NOTE**

During disassembly, progressively tape bladder openings to protect interior from foreign object contamination. During assembly, progressively remove protective tape.

CAUTION

D028-2 or -4 bladder assembly temperature should be above 65°F before removing, installing, or flexing bladder.

1. Remove aux fuel tank per § 12-20.
2. Remove hardware securing D247-2 bulkhead assembly and D253-3 angle to tank and remove angle. Detach hook and look tape and remove bulkhead.
3. Remove fuel quantity sender per § 12-51.
4. Remove screws securing D250-2 cover assembly to D028-2 or -4 bladder assembly and tank; carefully remove cover, with drain valve assembly attached. Remove and discard packing.
5. At vents, remove screw securing bladder to tank.
6. Remove fuel cap. Remove screws securing bladder to tank.
7. Detach hook and look tape and carefully remove bladder.
8. Carefully insert new D028-2 or -4 bladder assembly inside aux tank assembly. Ensure bladder is free of wrinkles across lower surface and properly located before joining hook & loop fastener. Bladder may be pressurized with air to 1 psi max to assist installation. Align bladder and tank fastener holes and press hook and loop tape together.
9. Install screws securing bladder to tank near fuel cap. Install fuel cap.
10. At vents, apply A257-9 anti-seize to threads and install screw securing bladder to tank.
11. Lubricate new packing with A257-6 grease and install packing in bladder groove at bottom of tank. Carefully insert cover into bladder, with drain valve assembly attached. Apply A257-9 anti-seize to threads and install screws securing cover to bladder and tank.
12. Install fuel quantity sender per § 12-51.
13. Align bulkhead and tank fastener holes. Install hardware securing bulkhead and angle to tank.
14. Pressure check assembled fuel tank by plugging vents and fittings and pressurizing bladder to no more than 1 psi. Check for leaks with a mild soap and water solution applied to all seams.
15. Install aux fuel tank per § 12-20.

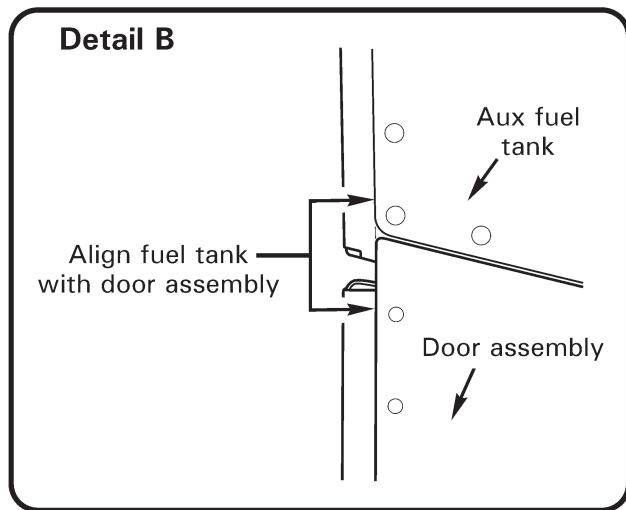
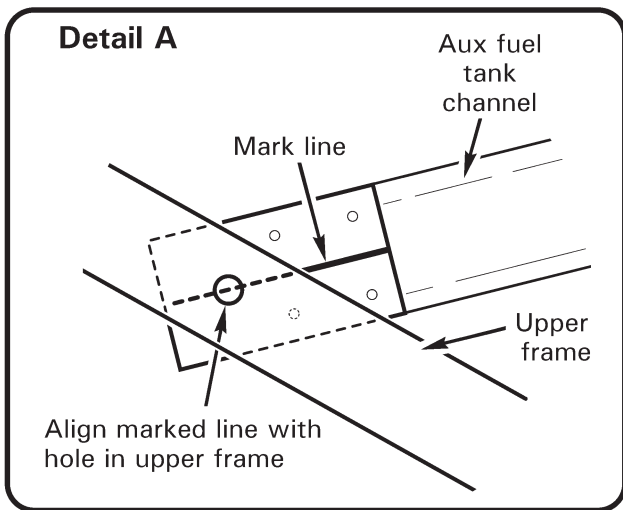
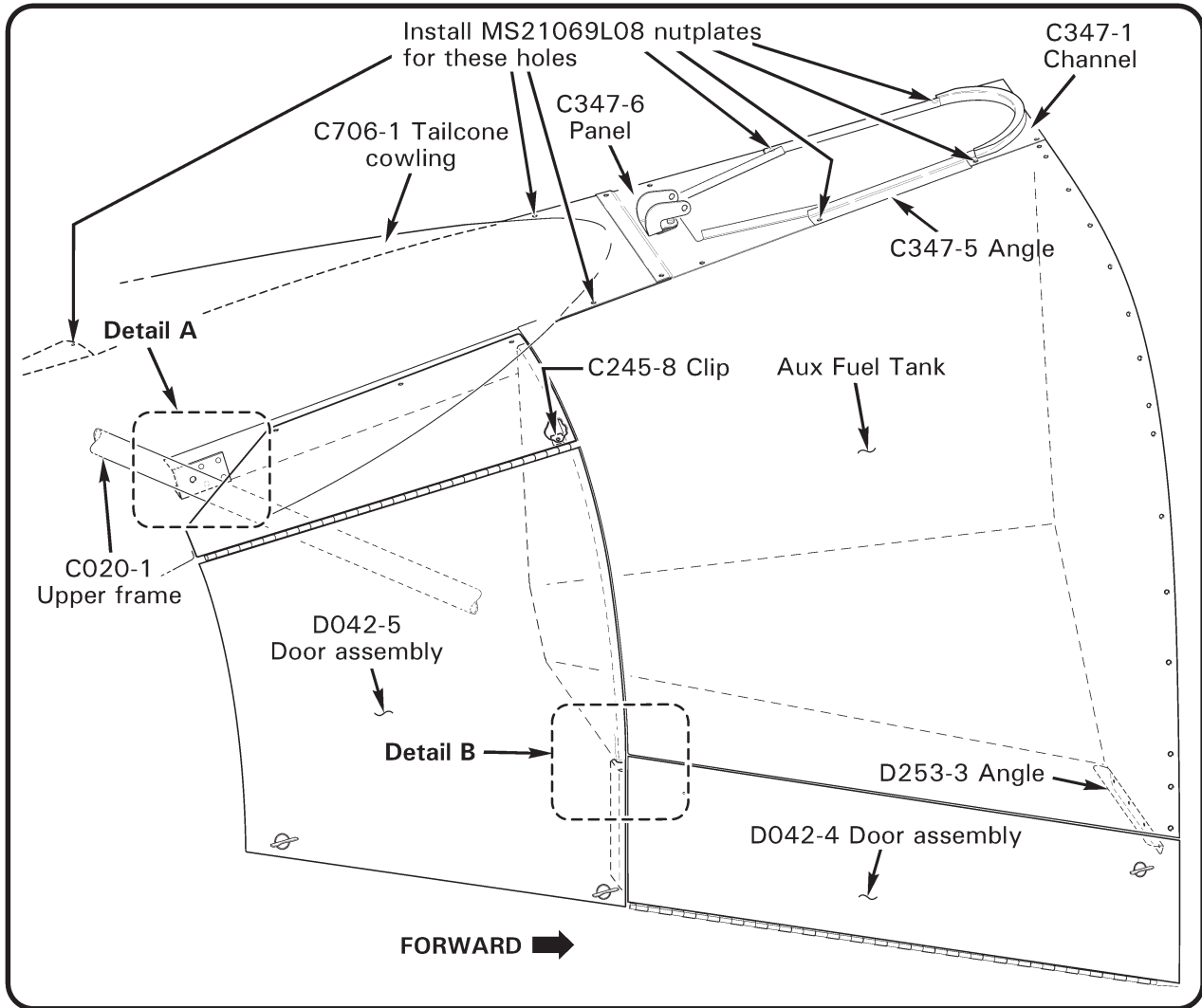

FIGURE 12-4 AUX TANK REPLACEMENT

12-22 Aux Tank Replacement

1. Remove aux fuel tank per § 12-20.
2. Refer to Figure 12-3, Detail C. Draw longitudinal lines from center of three bulkhead channel nut holes onto exterior skins. Measure and record distances as shown.
3. Refer to Figure 12-4, Detail A. Mark horizontal centerline of new D043-1 aux fuel tank channel doubler.
4. Position tank in helicopter. Align marked line with center of upper frame attachment hole per Figure 12-4, Detail A. Align tank exterior skin with aft edge of latched D042-4 door assembly per Detail B. Secure tank position by clamping channel to frame at attachment hole.
5. Refer to Figure 12-3, Detail D. Estimate material to be removed for fitting tank forward edge with cabin exterior skin aft edge; file or cut tank to create a gap of no more than 0.065 inch between tank and skin. Deburr trimmed edge with 220-grit or finer wet-or-dry aluminum oxide abrasive paper.
6. Conversion coat trimmed edge per § 23-51. Apply epoxy primer (ref. § 23-75) to trimmed edge.
7. From inside cabin, begin at the lowest nutplate and drill a #30 pilot hole through tank skin (using existing nutplate as drill guide), and install cleco. Moving upward, repeat step for remaining nutplates.
8. Transfer longitudinal lines and recorded distances from exterior skin to tank, and lay out three drill marks. Using a drill stop, enlarge pilot holes to 0.170-inch diameter.
9. Match-drill 0.250/0.256-inch hole in fuel tank channel through upper frame attachment hole; temporarily install bolt.
10. Refer to Figure 12-4. Open D042-4 door. Using a drill stop, match-drill 0.170-inch holes in C259-2 bulkhead through holes in D253-3 angle. Close and latch door.
11. Install D042-5 door assembly; latch door. Adjust door position for no more than 0.050-inch gap between door forward edge and tank skin edge, but maintain door-to-tank contour. Lay out hole location on C245-8 clip; verify drill hole on clip will have minimum 0.12-inch edge distance. Match-drill 0.170-inch hole in clip through door; install and secure screw.
12. Match-drill 0.170-inch holes in tank channel through holes in D042-5 door assembly.
13. Cleco C347-1 channel to cabin. Match-drill 0.170-inch holes in tank inboard flanges through remaining holes in channel.
14. Clean up debris. Install aux fuel tank per § 12-20.
15. Paint fuel cap alignment stripes and apply decal per § 12-13 Part B.

12-30 Fuel Vents

12-31 Roll-Over Valve Assemblies

R44 roll-over valve assemblies contain one brass ball. In normal conditions, air flows around the vent ball from the bladder expansion spaces. In the event of inadvertent over-filling or in-flight fuel sloshing, the ball will float and seal the vent. If the aircraft is inverted, the ball seals the vent to minimize fuel spillage. There are no internal packings.

A. Removal

1. Open mast fairing.
2. If installed, cut and discard ty-raps securing A729-63 tube between A729-48 tubes and remove A729-63 tube.
3. Loosen B277-4 clamp securing A729-48 tube to D251-1 roll-over valve assembly, pull A729-48 tube off of valve, and remove clamp.
4. Open lower D277-6 clamp (if installed, or cut and discard safety wire) securing A729-79 (or A729-47) tube to valve and pull valve through rib grommet.

B. Installation

1. Open lower D277-6 clamp (if installed), insert D251-1 roll-over valve assembly with arrow UP thru rib grommet and into A729-48 tube, and release clamp. If clamp is not installed, wrap two turns 0.032-inch diameter lockwire and safety A729-79 (or A729-47) tube tight to valve.
2. Position B277-4 clamp on A729-48 tube, insert tube on valve, and tighten clamp.
3. Install two MS3367-4-9 ty-raps thru A729-63 tube (if installed), with heads on opposite ends of tube. Secure one ty-rap to the other around one A729-48 tube; repeat around other A729-48 tube. Cinch ty-raps until snug without over-tightening and trim tips flush with heads.
4. Perform vent system check per Part C.

C. Vent System Check

1. Open mast fairing. Verify fuel caps are installed.
2. Attach temporary hose to one (of two) vent tubes.
3. Blow into the hose; do not use compressed air. Verify air blows out the other vent tube. If air does not blow out the other vent tube, remove obstruction(s) in vent line(s) or in bladder and repeat check.
4. Close mast fairing.

12-40 Drain Valves

A. Removal

1. Defuel helicopter per § 1.150. Remove engine right cowling, as required.
2. a. Gascolator Assembly: Open D277-6 clamps (or cut and discard safety wire if installed), pull A729-8 tube off of CAV-110H-4 or A761-1 drain valve, pull tube thru lower skin grommet, and remove tube.
b. Aux Fuel Tank and Main Tank Drain Hose: Cut and discard safety wire if installed (safety wire is no longer required in these locations); pull A729 tube off of A761-1 drain valve and remove tube.
3. Using backup wrench as required, remove valve from gascolator assembly, bulkhead connector, or aux tank fitting, as applicable. Tape fuel system opening.
4. To remove o-ring: actuate valve to expose stem and remove and discard o-ring.

B. Installation

1. If o-ring was removed, actuate A761-1 or CAV-110H-4 drain valve to expose stem, and install new o-ring in stem seat.
2. Lightly coat valve threads using B270-6 sealant. Remove tape and install valve in connector, tank, or gascolator assembly. Standard torque A761-1 valve in connector or tank per § 23-32, or special torque A761-1 or CAV-110H-4 valve in gascolator per § 23-33; torque stripe per Figure 5-1.
3. a. Gascolator Assembly: Insert A729-8 tube thru lower skin grommet, open D277-6 clamps, fit tube onto valve, and release clamps (if clamps are not installed, wrap tube with two turns 0.032-inch diameter lockwire, and safety tube to valve [2 places]). Verify security.
b. Aux Fuel Tank and Main Tank Drain Hose: Fit A729 tub onto drain valve (safety wire is no longer required in these locations). Verify security.
4. Fuel helicopter per applicable Pilot's Operating Handbook Section 2 and inspect fuel system for leaks. Install engine right cowling, if removed.

12-50 Fuel Quantity12-51 Fuel Quantity Senders**A. Removal**

1. a. D252-1 (main tank) fuel quantity sender: Remove main tank per § 12-10. Remove screws securing A374-5 angle to bladder assembly.
- b. D252-2 (aux tank) fuel quantity sender: Defuel helicopter per § 1.150. For R44s: disconnect C595-2 hose assembly from B254-3 strainer (or disconnect D205-29 hose assembly from elbow); for R44 IIs: disconnect C595-3 (or D205-29) and C595-4 (or D205-31) hose assemblies from tee.
2. D252-2 (aux tank) fuel quantity sender: Cut & discard ty-raps as required and disconnect fuel quantity sender wiring from airframe harness at connectors. Remove screws securing D250-2 cover assembly to bladder ring and tank and remove cover, with fuel quantity sender attached. Tape bladder opening.
3. Remove screws/bolts securing fuel quantity sender to cover assembly. Carefully pull sender lever through opening (main tank: tape bladder opening).
4. If required, using backup wrench on stud nuts, remove palnuts and nuts securing C049-11 connector assembly to fuel quantity sender and remove connector assembly.

B. Installation

1. Perform fuel quantity sender check per § 12-52.
2. If removed, install nuts securing C049-11 connector assembly to D252 fuel quantity sender; using backup wrench on stud nuts, special torque nuts per § 23-33, install new palnuts, and torque stripe per Figure 2-1.
3. Remove any tape, then carefully insert fuel quantity sender lever through opening in D250 cover assembly. Install hardware, special torque screws/bolts in criss-cross pattern per § 23-33, and torque stripe per Figure 2-1.
4. a. D252-1 (main tank) fuel quantity sender: Apply A257-9 anti-seize to screw threads and install screws securing A374-5 angle to bladder ring. Install main tank per § 12-10.
- b. D252-2 (aux tank) fuel quantity sender: Remove tape. Install D250-2 cover assembly with fuel quantity sender attached, carefully inserting lever in bladder. Apply A257-9 anti-seize to screw threads and install screws securing cover and A374-5 angle to bladder ring and tank. Connect sender wiring to airframe harness at connectors. Install ty-raps as required; cinch ty-raps until snug without overtightening and trim tips flush with heads.
5. Perform fuel quantity indication check per § 12-53. Verify no leaks.

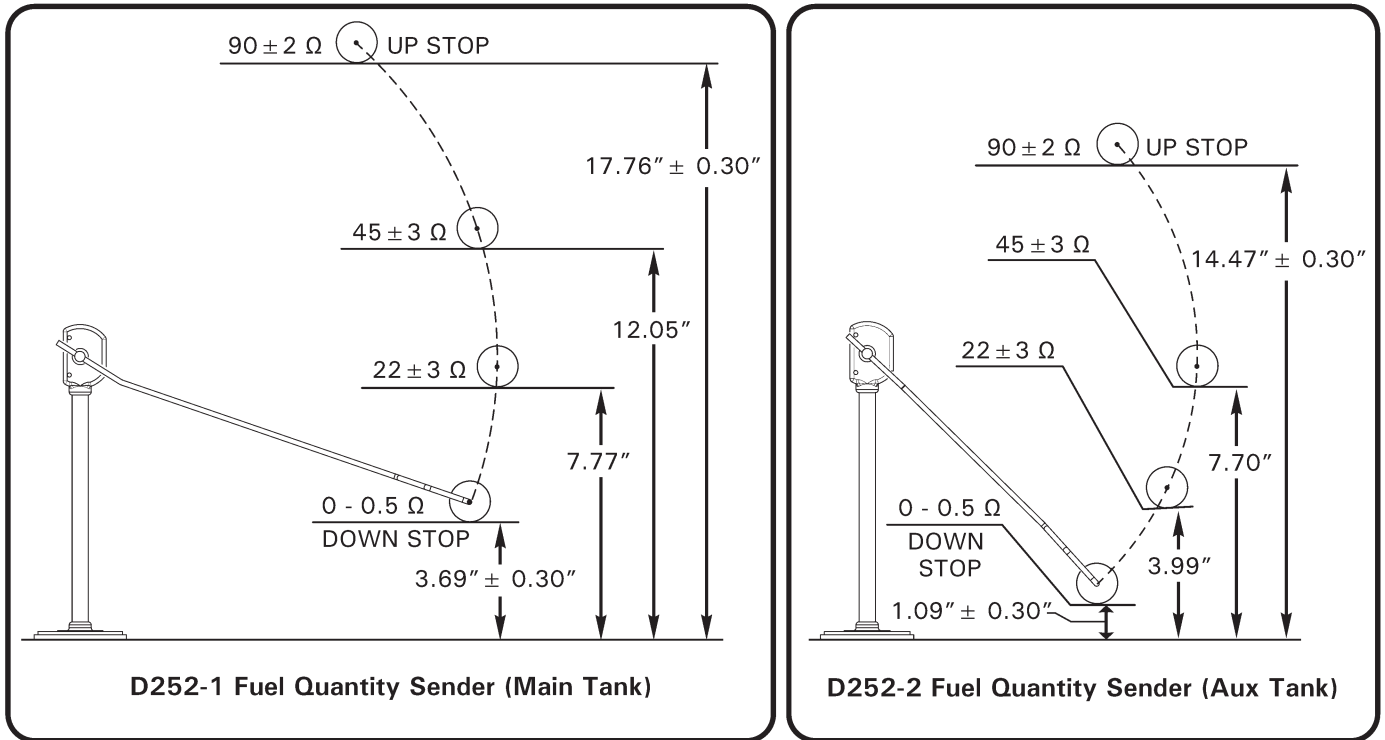

FIGURE 12-5 FUEL QUANTITY SENDER CHECK

12-52 Fuel Quantity Sender Check

1. Remove fuel quantity sender per § 12-51.
2. Simulate mounting position of appropriate sender per Figure 12-5. Position float arm as shown and measure the resistance with a multimeter. Verify resistance is within tolerance at four noted heights.
3. If resistance is out of tolerance at any height, bend the float arm up for a sender with excessive resistance, or bend the float arm down for a sender with too little resistance. Repeat steps until sender resistance is within tolerance.
4. Install fuel quantity sender per § 12-51.

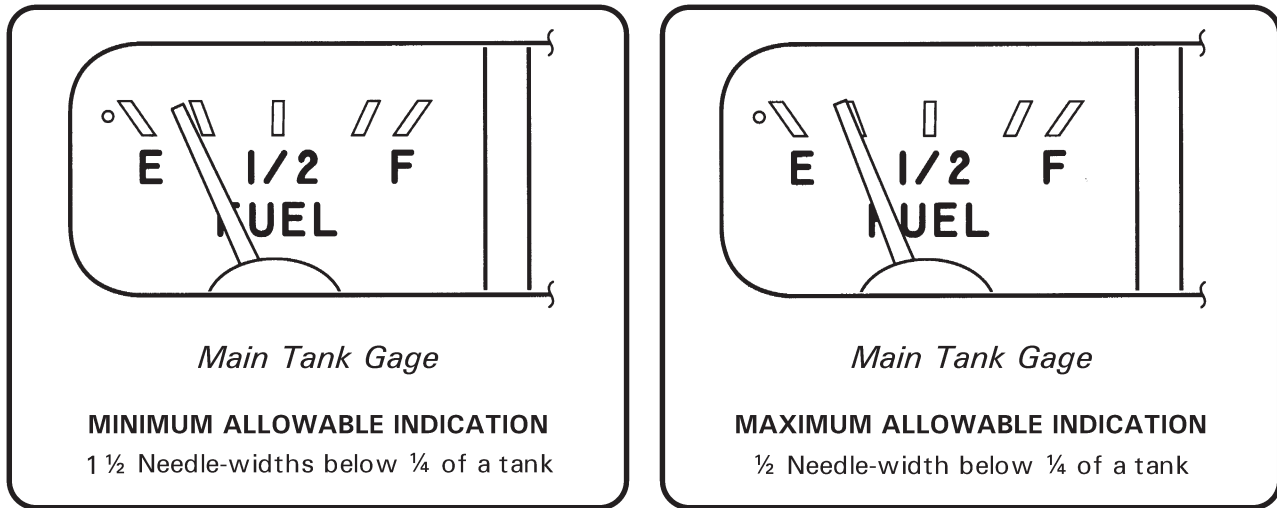

FIGURE 12-6 FUEL QUANTITY INDICATION CHECK

12-53 Fuel Quantity Indication Check

1. Defuel helicopter per § 1.150.
2. With ship level, fuel main tank with 9.25 gallons per applicable Pilot’s Operating Handbook Section 2. Wait five minutes for fuel levels to equalize (approximately 8 gallons in main tank and 1.25 gallons in aux tank). Inspect for leaks.
3. Turn battery switch on and read main tank fuel quantity gage. Verify main tank gage indicates one half to one and one half needle-widths below a quarter of a tank, as shown in Figure 12-6.
4. If indication is beyond allowable limit, perform fuel quantity sender check per § 12-52. If sender resistance is within tolerance, adjust fuel gage per § 37-110 Part D, or replace fuel gage and repeat check.

12-54 Low-Fuel Switch Assembly**CAUTION**

Avoid contaminating fuel bladder or tank interior. Cover arms with sleeves and use lint-free gloves when working inside interior.

A. Removal

1. Remove main fuel tank per § 12-10.
2. Remove A521-1 low-fuel switch assembly wiring pins from connector housing.
3. Remove fuel cap. Carefully capture switch assembly body with clean mechanical fingers (avoid capturing movable float). Remove A880-1005 (or AN924-5D) nut securing switch assembly to tank.
4. Carefully pull switch assembly through fuel cap opening (avoid fuel quantity sender). Install fuel cap, and tape fuel bladder or tank opening.

B. Installation

1. Lubricate new packing with A257-6 grease, and install packing over A521-1 low-fuel switch assembly threads.
2. Tape switch assembly wiring to 30-inch length of lockwire.
3. Remove fuel cap and tape. Position tank upside down. Thread lockwire through fuel cap opening and switch assembly mounting hole. Pull switch assembly wires and threads through mounting plate and retaining nut.
4. Apply light coat B270-1 sealant to A880-1005 (or AN924-5D) nut mating surface and install nut securing switch assembly to tank. Special torque nut per § 23-33 and torque stripe per Figure 2-1.
5. Insert wiring pins in connector housing; verify security.
6. Install main fuel tank per § 12-10.
7. Perform operation check per Part C.

C. Operation Check

1. Turn battery switch on. Fuel helicopter per applicable Pilot's Operating Handbook Section 2 as required and inspect fuel system for leaks.
2. With a clean wooden dowel, gently depress low-fuel switch assembly float and verify LOW FUEL warning light illuminates after approximately 1 second delay.
3. If warning light does not illuminate when float is depressed, but does illuminate when activating push-to-test switch, replace switch assembly.

Intentionally Blank

12-60 Gascolator Assembly and (R44 II) Aux Fuel Pump Installation**A. Cleaning Sediment Bowl**

1. Turn battery switch off. Turn fuel shut-off valve off. Remove right cowling assembly. Drain fuel using A666-1 gascolator assembly drain valve.
2. Clean exterior of gascolator, D743 electric (aux) fuel pump (R44 II), attached fittings, C741-1 line assembly, and B283-3 hose assembly.
3. Cut and discard safety wire securing gascolator collar to outlet fitting. Unscrew collar, and remove collar, ring (if installed), and sediment bowl.
4. Remove gasket & screen from gascolator top. Pull sediment bowl drain tube thru grommet and remove sediment bowl. Inspect, then clean, sediment bowl & screen.
5. Install screen and gasket in gascolator top. Apply light coat A257-6 grease to collar threads and collar inner flange. Verify large diameter of ring (if installed) contacts collar inner flange. Slide ring (if installed) and collar over bottom of sediment bowl so small diameter of ring engages groove in bowl flange. Position sediment bowl drain valve thru grommet in belly panel, and hand-tighten collar, ring (if installed), and bowl onto gascolator top until snug. Verify no threads exposed in gascolator top. Safety collar to outlet fitting using 0.032-inch diameter lockwire.
6. Turn fuel shut-off valve on. Verify no leaks.
7. Have a qualified person run-up and shutdown helicopter per applicable Pilot's Operating Handbook. Verify no leaks.
8. Install right cowling assembly.

12-60 Gascolator Assembly and (R44 II) Aux Fuel Pump Installation (continued)**B. Removal****CAUTION**

Temporarily cap fuel fittings when opened.

1. Pull AUX FUEL PUMP circuit breaker (R44 II). Turn battery switch off. Turn fuel shut-off valve off. Remove right cowling assembly. Drain fuel using A666-1 gascolator assembly drain valve.
2. Refer to Figure 12-7. Clean exterior of gascolator, D743 electric (aux) fuel pump (R44 II), attached fittings, C741-1 line assembly, and B283-3 hose assembly.
3. Cut and discard safety wire securing gascolator collar to outlet fitting. Disconnect C741-1 line assembly from gascolator inlet fitting.
4. a. R44: Disconnect B283-3 hose assembly from gascolator outlet fitting. If installed, disconnect primer line from AN894D4-2 bushing on gascolator outlet tee.
b. R44 II: Disconnect B283-3 hose assembly from aux pump tee or elbow, as applicable.
5. R44 II: Cut and discard ty-raps as required and disconnect D745-1 vacuum switch and aux pump wiring from airframe harness at connectors. Mark and disconnect wires from B426-2 fuel pressure switch.
6. R44 II: Remove hardware securing aux pump drain tube clamp to vertical firewall. Open HTM-300 clamp securing aux pump to D742-1 support and clip on firewall.
7. Remove nut and washer securing gascolator to A454-1 support and remove gascolator, or aux pump with attached gascolator, as applicable.
8. R44 II: As required, separate gascolator from pump by disconnecting adapter from elbow. As required, remove pump inlet and outlet hardware, remove and discard packings, and remove pressure switch.
9. As required, remove gascolator inlet and outlet fitting(s). Remove vacuum switch (R44 II).

12-60 Gascolator Assembly and (R44 II) Aux Fuel Pump Installation (continued)**C. Gascolator Installation (R44)**

1. As required, install fittings in A666-1 gascolator assembly per the following: Apply light coat B270-6 sealant to A880-536 or -566 adapter (or AN816-6D nipple), or outlet tee (if primer system equipped) threads (do not apply sealant to first thread); install fittings in gascolator and standard torque per § 23-32.
2. Position gascolator in helicopter; route drain tube thru grommet in belly and insert A455-1 plug in A454-1 support. Connect C741-1 line assembly to gascolator inlet, finger-tight.
3. Note any gap between bottom of A454-1 support and shoulder of A455-1 plug; fill gap as required by adjusting support vertically (or installing NAS1149F0432P washers on plug if support does not have slotted holes). Install washer and nut on plug, special torque nut per § 23-33, and torque stripe per Figure 2-1.
4. Special torque C741-1 line assembly nut per § 23-33, & torque stripe per Figure 2-1.
5. If primer system equipped, assemble AN894D bushings on gascolator outlet tee and connect D101-3 line assembly to bushing. Using backup wrench, special torque bushings per § 23-33, special torque D101-3 line assembly nut per § 23-33, and torque stripe per Figure 2-1.
6. Connect B283-3 hose assembly to gascolator outlet fitting, special torque hose assembly nut per § 23-33, and torque stripe per Figure 2-1.
7. Safety gascolator collar to outlet fitting using 0.032-inch diameter lockwire.
8. Turn fuel shut-off valve on. Verify no leaks.
9. Have a qualified person run-up and shutdown helicopter per applicable Pilot's Operating Handbook. Verify no leaks.
10. Install right cowling assembly.

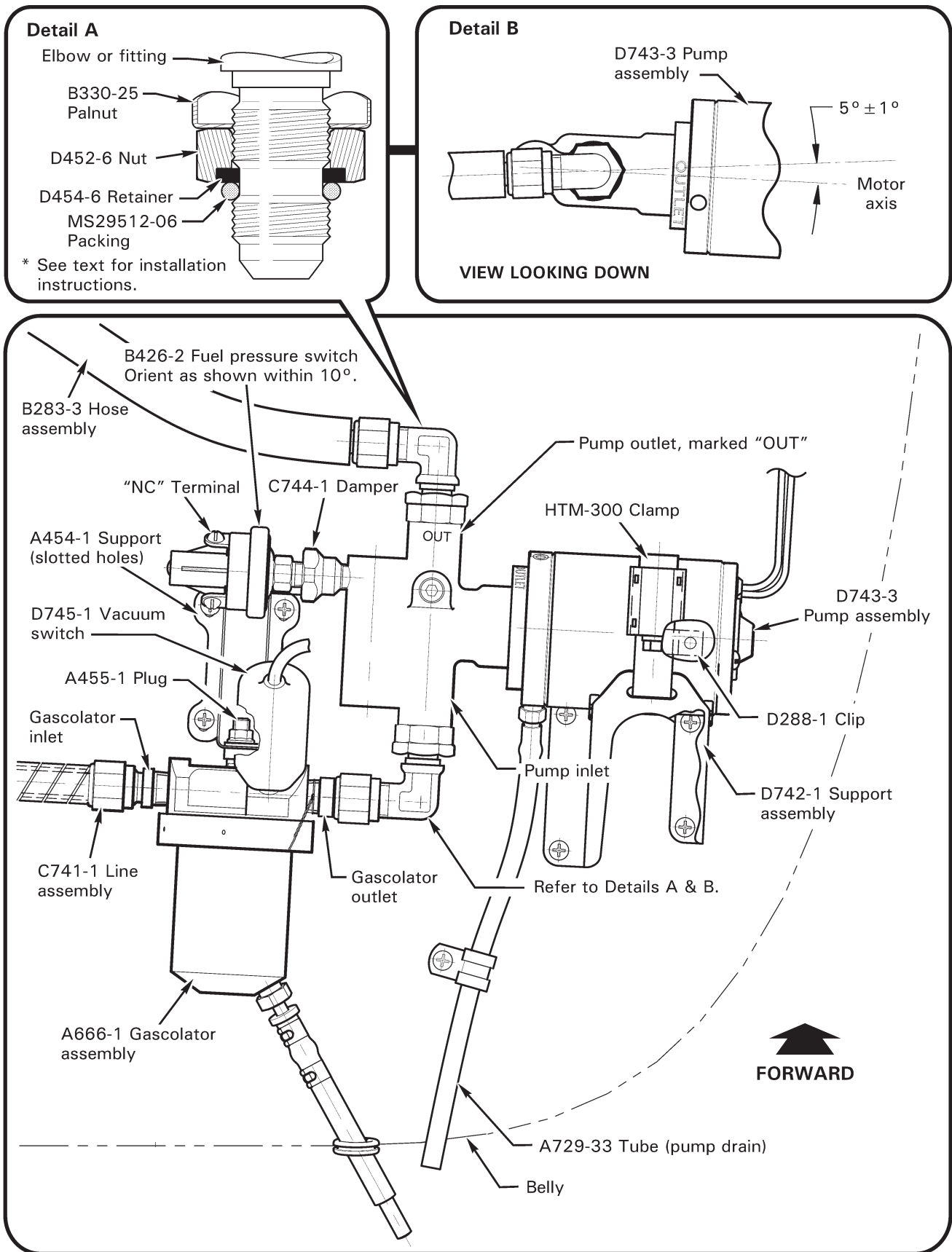

FIGURE 12-7 GASCOLATOR ASSEMBLY AND (R44 II) AUX FUEL PUMP INSTALLATION

12-60 Gascolator Assembly and (R44 II) Aux Fuel Pump Installation (continued)**D. Gascolator and (R44 II) Aux Fuel Pump Installation**

1. Refer to Figure 12-7. As required, install fittings in D743 aux fuel pump assembly per the following:
 - a. Refer to Figure 12-7 Detail A. Install (new) B330-25 palnut, D452-6 nut (orient counterbore as shown), and D454-6 retainer on elbow or tee; press retainer completely into counterbore of nut. Lubricate (new) MS29512-06 packing using A257-6 grease and install as shown; turn nut and palnut down by hand so packing is against lower threaded section of fitting.
 - b. Screw fitting into aux pump; ensure nut and palnut rotate with fitting until packing contacts pump (indicated by a sudden increase in torque). Hold nut and palnut with wrench and screw fitting into pump one-half turn, plus one turn maximum; align inlet elbow parallel to pump motor axis and align outlet fitting per Figure 12-7 Detail B to pump motor axis. Hold fitting with wrench, special torque D452-6 nut per § 23-33, special torque palnut per § 23-33, and torque stripe per Figure 2-1.
2. As required, install C744-1 damper and B426-2 pressure switch in aux pump per the following: Apply light coat B270-6 sealant to C744-1 damper threads (do not apply sealant to first thread), install damper in aux pump, and standard torque C744-1 damper to 60 in.-lb. Apply light coat B270-6 sealant to B426-2 switch (do not apply sealant to first thread), install switch on C744-1 damper, and standard torque switch to 60 in.-lb. Tighten switch (tighter only, do not loosen) as required to orient NC terminal within 10° as shown.
3. As required, install fittings and D745-1 vacuum switch in A666-1 gascolator assembly per the following: Apply light coat B270-6 sealant to A880-536 or -566 adapter (or AN816-6D nipple) threads (do not apply sealant to first thread); install fitting in gascolator inlet and standard torque per § 23-32. Apply light coat B270-6 sealant to A457-11 adapter (or 6505-04-06-SS adapter) threads (do not apply sealant to first thread); install fitting in gascolator outlet and special torque per § 23-33. Apply light coat B270-6 sealant to vacuum switch threads (do not apply sealant to first thread); install switch in gascolator and standard torque to 60 in.-lb.
4. Connect gascolator adapter to aux pump lower elbow. Align gascolator A455-1 plug to point up and parallel with pump inlet, special torque adapter nut per § 23-33, and torque stripe per Figure 2-1.
5. Position aux pump with attached gascolator in helicopter; route gascolator drain tube thru grommet in belly, insert A455-1 plug in A454-1 support, and rest aux pump motor on D742-1 support. Connect C741-1 line assembly to gascolator inlet, finger-tight.

12-60 Gascolator Assembly and (R44 II) Aux Fuel Pump Installation (continued)**D. Gascolator and (R44 II) Aux Fuel Pump Installation (continued)**

6. Note any gap between bottom of A454-1 support and shoulder of A455-1 plug; fill gap as required by adjusting support vertically (or installing NAS1149F0432P washers on plug if support does not have slotted holes). Install washer and nut on plug, special torque nut per § 23-33, and torque stripe per Figure 2-1.
7. Special torque C741-1 line assembly nut per § 23-33, & torque stripe per Figure 2-1. Verify two layers of 10.0/10.5-inch length, B161-8 spirap insulation covering line between firewall and nut. Install new spirap as required.
8. Insert HTM-300 clamp around aux pump motor, through clip on vertical firewall and slot in D742-1 support. Special torque clamp per § 23-33 and torque stripe per Figure 2-1. Install hardware securing aux pump drain tube clamp to vertical firewall. Route tube thru hole in belly.
9. Connect B283-3 hose assembly to aux pump elbow (or tee), special torque hose assembly nut per § 23-33, and torque stripe per Figure 2-1.
10. Safety gascolator collar to outlet fitting using 0.032-inch diameter lockwire.
11. Connect vacuum switch and aux pump wiring to airframe harness at connectors. Connect wires (as marked) to pressure switch. Install ty-raps as required.
12. Turn fuel shut-off valve on. Verify no leaks.
13. Push in AUX FUEL PUMP circuit breaker. With mixture control off and master switch on, verify AUX FUEL PUMP caution light is illuminated. Turn ignition switch to PRIME for one minute and verify AUX FUEL PUMP light extinguishes and pump operates with a continuous, steady tone. Turn master switch off. Verify no leaks.
14. Have a qualified person run-up and shutdown helicopter per R44 II Pilot's Operating Handbook. Verify no leaks.
15. Install right cowling assembly.

12-70 Minimum Fuel Flow Check

1. Fuel main tank with approximately 5 gallons (30 lb) fuel per applicable Pilot’s Operating Handbook Section 2, as required. Remove right cowling assembly.
2. Electrically ground helicopter, and turn fuel shut-off valve off.
3. a. R44: Disconnect B283-3 hose assembly from carburetor, turn battery switch and fuel shut-off valve on, and defuel helicopter into an approved, electrically grounded container until LOW FUEL light illuminates. Turn battery switch and fuel shut-off valve off.
 b. R44 II: Cut and discard safety wire securing gascolator collar to outlet fitting. Unscrew collar, and remove collar, ring (if installed), and sediment bowl; remove gasket and screen from gascolator top. Turn battery switch and fuel shut-off valve on, and defuel helicopter into an approved, electrically grounded container until LOW FUEL light illuminates. Turn battery switch and fuel shut-off valve off.
4. Place electrically-grounded, calibrated container beneath hose or gascolator, turn fuel shut-off valve on, and record time required to fill container. Verify filling time does not exceed maximum time listed below:

ALLOWABLE FUEL FLOW RATE	
<i>QUANTITY</i>	<i>MAXIMUM TIME</i>
1 U.S. Gallon	90 seconds
4 Liters	95 seconds
1 Imperial Gallon	108 seconds

5. If filling time is exceeded, perform vent system check per § 12-31 Part C. Inspect fuel tank outlet strainer, line assembly, and hose assemblies for obstructions. Remove obstructions and repeat check.
6. a. R44: Connect B283-3 hose assembly to carburetor, special torque nut per § 23-33, and torque stripe per Figure 2-1.
 b. R44 II: Inspect, clean, and install screen and gasket in gascolator top. Apply light coat A257-6 grease to collar threads and collar inner flange. Verify large diameter of ring (if installed) contacts collar inner flange. Slide ring (if installed) and collar over bottom of sediment bowl so small diameter of ring engages groove in bowl flange. Position sediment bowl drain valve thru hole in belly panel, and hand-tighten collar, ring (if installed), and bowl onto gascolator top until snug. Verify no threads exposed in gascolator top. Safety collar to outlet fitting using 0.032-inch diameter lockwire.
7. Perform ground check and run up per §§ 2.205 & 2.210. Verify no leaks.
8. Install right cowling assembly.

12-80 R44 II Troubleshooting

PROBLEM	POSSIBLE CAUSE	CORRECTION
FUEL FILTER warning light illuminates during flight	Fuel system contaminated Fuel tank vents obstructed Vacuum switch contaminated	Inspect gascolator and fuel control inlet screens for contamination. Inspect fuel system for obstructions or debris and correct cause. Inspect vents for contamination. Correct cause. Replace vacuum switch.
AUX FUEL PUMP warning light illuminates during flight	Insufficient fuel quantity Aux fuel pump output insufficient Failed pressure relief valve assembly	Add fuel. Replace aux fuel pump per § 12-60. Perform pressure relief valve leakage check per § 12-83.
Fuel draining from intake manifold "sniffle" drain valve	Engine-driven fuel pump diaphragm failure Flow divider piston stuck open	Replace engine-driven fuel pump. Perform flow divider check per § 12-81.
Fuel draining from electric (auxiliary) fuel pump drain	Failed seal in aux fuel pump	Replace aux fuel pump, or return aux fuel pump to http://weldonpumps.com for repair.
Oil draining from engine-driven fuel pump drain	Leaking diaphragm	Replace engine-driven fuel pump.

12-81 Flow Divider Internal Leakage Check

NOTE
Refer to Lycoming Service Instruction No. 1518 for information on stuck-closed flow divider.

1. Fully fuel helicopter. Turn battery switch off. Electrically ground helicopter.
2. Place electrically-grounded, suitable container beneath the intake manifold "sniffle" drain valve.
3. Turn fuel shut-off valve on. Push mixture control into FULL RICH position. Wait 15 minutes, then inspect container for evidence of fuel leaking from drain valve.
4. Replace or repair flow divider if fuel is found in container.

12-82 Injection Nozzle Comparative Flow Check

NOTE

Refer to Precision Airmotive Form 15-810B "Troubleshooting Techniques," Lycoming SSP-1776 "Service Table of Limits," and Lycoming SB 342 (current revision; ref [AD 2011-26-04](#)).

1. Turn battery switch off. Electrically ground helicopter. Remove engine left & right cowlings and upper spark plug access panels.
2. Remove injection nozzles from cylinders and reinstall nozzles on delivery lines. Place a calibrated container beneath each nozzle.
3. Turn fuel shut-off valve on. Rotate twist grip OPEN. Activate aux fuel pump by turning key to PRIME position.
4. Push mixture control into FULL RICH position for 15 to 30 seconds then pull mixture to off; verify volume collected is similar between all injection nozzles. If volume is not similar, isolate cause (nozzle, delivery line, flow divider fitting, flow divider) and repair.
5. Install nozzles and delivery lines and torque per Lycoming SSP-1776.
6. Install upper spark plug access panels and engine left & right cowlings.

12-83 Pressure Relief Valve Leakage Check

Verify sufficient fuel in aux tank. Disconnect fuel control-to-pressure relief valve hose assembly from fuel control inlet tee and drain residual fuel into an electrically-grounded, suitable container. If fuel drains continuously from hose assembly, replace pressure relief valve assembly.

Intentionally Blank

CHAPTER 13

INSTRUMENT SYSTEM

<u>Section</u>	<u>Title</u>	<u>Page</u>
13-00	Description	13.1
13-10	Pitot-Static System	13.3
13-20	Primary Instruments	13.4
13-21	Vertical Speed Indicator	13.4
13-22	Airspeed Indicator	13.6
13-23	Dual Tachometer	13.7
13-24	Altimeter	13.9
13-25	Manifold Pressure Gage	13.10
13-26	Magnetic Compass	13.11
13-30	Engine Gages	13.12
13-31	Ammeter	13.12
13-32	Engine Oil Pressure Gage	13.13
13-33	Engine Oil Temperature Gage	13.14
13-34	Cylinder Head Temperature Gage	13.14
13-35	Fuel Quantity Gages	13.15
13-36	Carburetor Air Temperature Gage (O-540)	13.15
13-40	Additional Standard Indicating Equipment	13.16
13-41	Clock	13.16
13-42	Outside Air Temperature (OAT) Gage/Voltmeter	13.17
13-43	Hourmeter	13.18
13-50	Senders and Sensors	13.19
13-51	Oil Temperature Senders	13.19
13-52	Cylinder Head Temperature Senders	13.20
13-53	Outside Air Temperature (OAT) Senders	13.23
13-54	Engine Tachometer Hall Effect Sensor	13.24
13-60	Instrument Markings	13.24
13-70	Electronic Flight Displays	13.26
13-71	Garmin Display Unit (GDU) 700L	13.26
13-72	Garmin Display Unit (GDU) 620	13.29
13-73	Aspen EFD500H & EFD1000H Display(s)	13.33
13-80	Console Assemblies	13.37

Intentionally Blank

CHAPTER 13

INSTRUMENT SYSTEM

13-00 Description

Standard primary instruments include an airspeed indicator, engine and rotor dual tachometer, altimeter, manifold pressure gage, and magnetic compass. Engine gages include an ammeter, oil pressure, oil temperature, cylinder head temperature, and fuel quantity for main and aux tanks. Also standard are a clock, a carburetor air temperature gage, and a digital outside air temperature gage. A collective-activated hourmeter is located right of the pilot's seat and may be used for recording time in service. (Older R44s may have an hourmeter activated by engine oil pressure.)

For instrument panels with electronic flight displays, a P/N D327 light filter may be used to reduce reflections in the windshield at night. The light filter is installed by clipping it to the front of the display. Filter use is at pilot discretion.

The pitot-static system supplies air pressure to operate the airspeed indicator, altimeter, and vertical speed indicator. The pitot tube is located on the front edge of the mast fairing. The static sources are located on each side of the cabin aft of the rear doors.

Water can be drained from pitot-static lines by removing the plastic drain plugs which are accessible through the forward inspection panel on the underside of the cabin. Draining lines should be required only if the airspeed indicator or altimeter appears erratic.

Pitot and static sources should be inspected frequently for bugs or other obstructions.

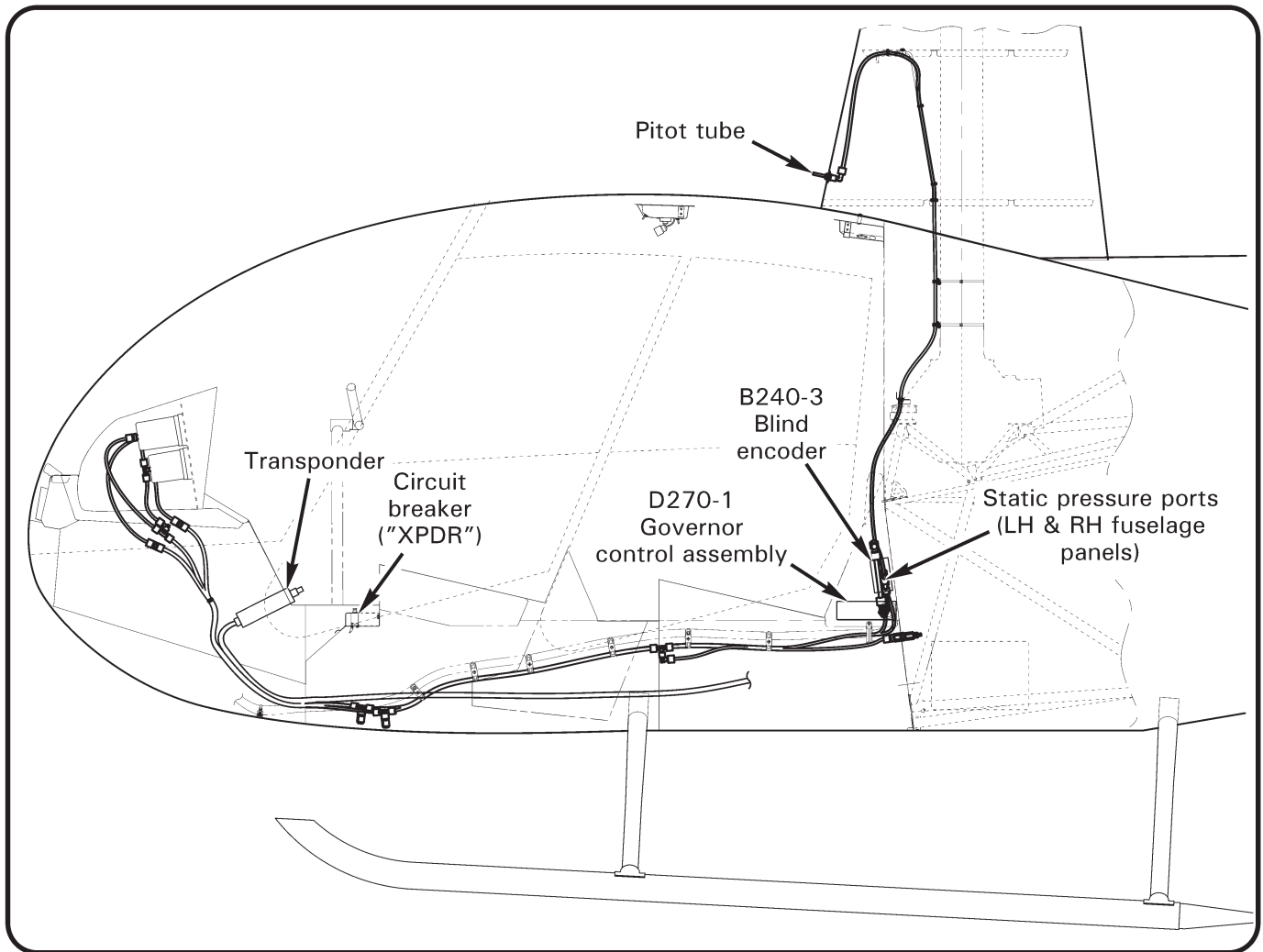
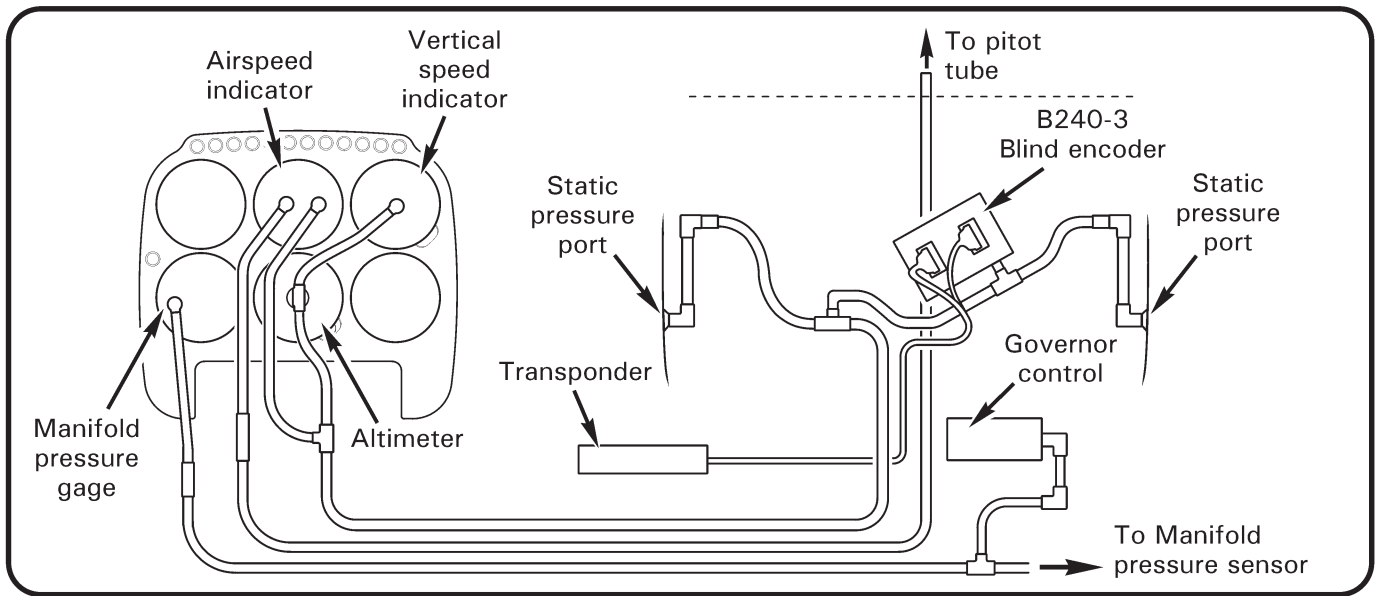

FIGURE 13-1 PITOT-STATIC SYSTEM (SHOWN WITH DIGITAL GOVERNOR)

13-10 Pitot-Static System

CAUTION

Do not apply suction to pitot system or pressure to static system.

A. Pitot System Leak Test

1. Open mast fairing.
2. Refer to Figure 13-1. Seal drain hole in elbow aft of pitot tube with pressure-sensitive tape. Connect a medical syringe, with plunger withdrawn, to pitot tube via flexible tubing.
3. Slowly apply pressure to pitot line by depressing syringe plunger until airspeed indicator reads 70 knots (plunger will remain in place).
4. Gently tap airspeed indicator glass to remove friction effects.
5. If airspeed indication drops more than 10 knots in one minute, an unacceptable leak is indicated. Slowly release pressure. Locate and repair any leak(s). Retest after any repairs.
6. Remove tape from pitot tube drain hole and verify airspeed indicator has returned to zero.
7. Remove test equipment. Close mast fairing.

B. Static System Leak Test

CAUTION

Airspeed indicator, altimeter, and vertical speed indicator may be damaged if suction to static line is applied or removed rapidly.

1. Refer to Figure 13-1. Set altimeter to location elevation.
2. Temporarily seal left or right side static opening with pressure sensitive tape. Cover remaining static port with a suction cup attached to a medical syringe, with plunger depressed.
3. Slowly apply suction to static port by withdrawing syringe plunger until altimeter indicates 500 feet greater than location elevation (plunger will remain in place).
4. If altimeter indication drops more than 100 feet in one minute, an unacceptable leak is indicated. Slowly release suction. Locate and repair leak(s). Retest after any repairs.
5. Remove test equipment.

13-20 Primary Instruments13-21 Vertical Speed Indicator**A. Description**

The vertical speed indicator indicates rate of ascent or descent. Check vertical speed indicator for a zero-rate needle indication when rotorcraft is in a stationary hover.

B. Diagram

Refer to Figure 13-1 for pitot-static system diagram.

C. Removal**CAUTION**

Protect instrumentation using foam padding or equivalent. Handle instruments like eggs.

1. Turn battery switch off and pull out applicable circuit breaker(s).
2. Remove perimeter screws securing face to console and pull face aft.
3. Remove screws securing instrument to face.
4. Disconnect wiring as applicable.
5. Disconnect pitot/static lines and cap & plug instrument and system fittings, as applicable.
6. Remove instrument and place on foam padding.

D. Installation**CAUTION**

Protect instrumentation using foam padding or equivalent. Handle instruments like eggs.

1. Turn battery switch off and pull out applicable circuit breaker(s).
2. Remove caps and plugs and connect pitot/static lines. Verify security.
3. Connect wiring as applicable. Verify security.
4. Install screws securing instrument to face. Verify security.
5. Install perimeter screws securing face to console. Verify security.
6. Perform pitot-static system checks as required per § 13-10.
7. Perform appropriate function checks per § 2.200.

13-21 Vertical Speed Indicator (continued)**E. Scheduled Maintenance and Inspections**

Refer to § 2.400 100-Hour/Annual Inspection.

F. Special Maintenance and Inspections

1. If vertical speed indicator displays climb indication but does not return to zero in level flight, or if indication is erratic:
 - a. Inspect static system for water or obstructions, and remove water or obstructions if found.
 - b. Perform pitot-static system checks as required per § 13-10.
2. Perform appropriate function checks per § 2.200. If vertical speed indicator still displays erratic indication, or displays no indication, remove indicator per Part C, and return to RHC for inspection.
3. Install airworthy indicator per Part D.

13-22 Airspeed Indicator

A. Description

The airspeed indicator displays airspeed in knots and miles or kilometers per hour. The airspeed indicator operates properly in forward flight only; backward or lateral flight will not indicate correct airspeed. The airspeed indicator will indicate airspeeds up to a maximum of 130 knots (red line) for R44s and R44 IIs, and up to a maximum of 120 knots (red line) for R44 Cadet.

B. Diagram

Refer to Figure 13-1 for pitot-static system diagram.

C. Removal

Remove airspeed indicator per § 13-21 Part C.

D. Installation

Install airspeed indicator per § 13-21 Part D.

E. Scheduled Maintenance and Inspections

Refer to § 2.400 100-Hour/Annual Inspection.

F. Special Maintenance and Inspections

1. If airspeed indicator displays no indication:
 - a. Inspect pitot tube for obstructions and remove obstructions if found.
 - b. Inspect pitot tube connection, and tighten connection if loose.
 - c. Open upper console and inspect pitot line for kinks or bends.
 - d. Perform pitot-static system checks as required per § 13-10.
 - e. Perform appropriate function checks per § 2.200. If indicator still displays no indication, remove indicator per Part C, and return to RHC for inspection.
 - f. Install airworthy indicator per Part D.
2. If airspeed indicator displays erratic indication:
 - a. Inspect pitot-static system connection(s), and tighten connection(s) if loose.
 - b. Inspect pitot-static system lines and verify no lines are cracked or broken.
 - c. Inspect pitot-static system for water, and remove water if found.
 - d. Open upper console and inspect pitot lines for kinks or bends.
 - e. Perform pitot-static system checks as required per § 13-10.
 - f. Perform appropriate function checks per § 2.200. If indicator still displays erratic indication, remove indicator per Part C, and return to RHC for inspection.
 - g. Install airworthy indicator per Part D.

13-23 Dual Tachometer**A. Description****CAUTION**

Installation of electrical devices can affect accuracy and reliability of electronic tachometers.

An electronic engine and rotor dual tachometer is standard. Engine tachometer signal is provided by magneto breaker points. Rotor tachometer signal is provided by two magnetic senders at the main gearbox drive yoke. Each tachometer is on a separate circuit with its own circuit breaker. With battery and alternator switches off, the tachometers continue to receive power from the battery through a bypass circuit as long as the clutch actuator switch is in the engage position.

NOTE

Do not stow helicopter with clutch switch engaged. The tachometers are powered with the clutch engaged and will discharge the battery.

NOTE

Do not use magnetized tools.

CAUTION

Protect instrumentation using foam padding or equivalent. Handle instruments like eggs.

B. Removal

1. Turn battery switch off and pull out TACHS E (2 amp) and R (2 amp) circuit breakers at panel.
2. Remove perimeter screws securing instrument face to console and pull face aft.
3. Remove screws securing console harness connector to C792 dual tachometer and unplug connector.
4. Supporting instrument, remove screws securing tachometer to face, and remove tachometer.

13-23 Dual Tachometer (continued)**C. Installation**

1. Turn battery switch off and pull out TACHS E (2 amp) and R (2 amp) circuit breakers at panel.
2. Install screws securing C792 dual tachometer to instrument face. Verify security.
3. Plug in console harness connector to tachometer and install connector screws. Verify security.
4. Install perimeter screws securing face to console. Verify security.
5. Perform accuracy check and needle synchronization per Part D.

D. Adjustment**NOTE**

Adjust rotor tachometer if engine and rotor tachometer needles are not within 1% of each other at 102% RPM.

1. Remove screws securing instrument face panel to upper console and carefully pull panel aft.
2. Run-up helicopter per R44, R44 II, or R44 Cadet Pilot's Operating Handbook (POH) Section 6 at 102% engine tachometer indication.
3. Turn adjustment screw on back of tachometer (apply 1/8 turns) clockwise to increase and counterclockwise to decrease rotor tachometer indication. Adjust rotor tachometer to indicate 102%.
4. Shutdown helicopter per POH Section 6. Tighten screws securing instrument panel to upper console.

E. Scheduled Maintenance and Inspections

Refer to § 2.400 100-Hour/Annual Inspection.

Refer to §§ 2.600 & 2.700 for additional component maintenance.

F. Special Maintenance and Inspections

1. Perform adjustment as required per Part D.
2. If tachometer cannot be adjusted, remove tachometer per Part B, and return to RHC for inspection.
3. Install airworthy tachometer per Part C.

13-24 Altimeter

A. Description

The sensitive altimeter provides altitude information relative to mean sea level when the barometric pressure correction scale is properly set. Check altimeter calibration by setting correction scale to the current altimeter setting and checking the altimeter reading against field elevation; they must agree within 70 feet.

B. Diagram

Refer to Figure 13-1 for pitot-static system diagram.

C. Removal

Remove altimeter per § 13-21 Part C.

D. Installation

Install altimeter per § 13-21 Part D.

E. Scheduled Maintenance and Inspections

Refer to § 2.400 100-Hour/Annual Inspection.

F. Special Maintenance and Inspections

1. If altimeter displays no indication:
 - a. Inspect static lines for obstructions and remove obstructions if found.
 - b. Perform pitot-static system checks as required per § 13-10.
 - c. Perform appropriate function checks per § 2.200. If altimeter still displays no indication, remove altimeter per Part C, and return to RHC for inspection.
 - d. Install airworthy altimeter per Part D.
2. If altimeter displays erratic indication:
 - a. Inspect static system for water, and remove water if found.
 - b. Perform pitot-static system checks as required per § 13-10.
 - c. Perform appropriate function checks per § 2.200. If altimeter still displays erratic indication, remove altimeter per Part C, and return to RHC for inspection.
 - d. Install airworthy altimeter per Part D.

13-25 Manifold Pressure Gage

A. Description

The manifold pressure gage provides an indicator of absolute air pressure in the engine intake manifold. The red line on the gage indicates the maximum manifold pressure that the rotorcraft is type certificated for at 102% rotor RPM. The manifold pressure gage should indicate within 0.3 inches Hg of ambient barometric pressure when engine is not running.

B. Removal

Remove manifold pressure gage per § 13-21 Part C.

C. Installation

Install manifold pressure gage per § 13-21 Part D.

D. Scheduled Maintenance and Inspections

Refer to § 2.400 100-Hour/Annual Inspection.

E. Special Maintenance and Inspections

Manifold Pressure System Leak Check

1. Disconnect C740-1 (O-540) or D740-1 (IO-540) line assembly from engine fitting.
2. Connect a medical syringe, with plunger depressed, to line assembly fitting via flexible tubing.
3. Slowly apply suction to system by withdrawing syringe plunger until manifold pressure gage indicates 10 inches Hg (plunger will remain in place).
4. If manifold pressure gage indication rises more than one inch in one minute, an unacceptable leak is indicated. Slowly release suction. Locate and repair leak(s). Retest after any repairs.
5. Remove test equipment.

13-26 Magnetic Compass

A. Description

An internally illuminated, wet-type compass is attached to the center bow between the windshields above the instrument panel.

B. Schematic

Refer to Figure 14-21 for electrical schematic.

C. Removal

1. Remove hardware securing compass mount to windshield bow.
2. Remove hardware securing compass assembly to mount.
3. Remove heat shrink as required and disconnect light bar wires from airframe harness. Remove compass.

D. Installation

1. Install heat shrinks over wires and connect compass assembly's light bar wires to airframe harness. Verify security. Activate heat shrinks.
2. Install hardware securing compass to mount. Verify security.
3. Install hardware securing mount to windshield bow. Verify security.
4. At governed RPM, using the airport compass rose, align the helicopter skids on the rose lines, and record the indicated compass headings at 30° increments. Adjust compass compensator magnets as required until the maximum error at any heading is 5° or less with all avionics operating, all exterior lights on, and dimmer full bright. Record the final readings on the aircraft compass card. Re-check 4 cardinal headings with lights off and all avionics off except COM radio 1 and transponder. Verify maximum error remains 5° or less.

E. Scheduled Maintenance and Inspections

Refer to § 2.400 100-Hour/Annual Inspection.

F. Special Maintenance and Inspections

1. Perform compass deviation check per Part D step 4.
2. If compass cannot be adjusted to limits specified, remove compass per Part C, and install airworthy compass per Part D.

13-30 Engine Gages

13-31 Ammeter

A. Description

The ammeter indicates electrical system loads. System load is measured across the A780 cable (shunt; cable is calibrated, do not alter cable).

B. Schematic

Refer to Figure 14-21 for electrical schematic.

C. Instrument Cluster Removal

1. Turn battery switch off and pull out applicable circuit breaker(s).
2. Remove electronic flight display(s) per § 13-70, if installed.
3. Remove screws securing upper console to lower console and tilt upper console aft.
4. Remove nuts securing console wiring to B144 instrument cluster and remove wiring.
5. Remove screws securing instrument cluster to shell assembly's face plate and remove instrument cluster.

D. Instrument Cluster Installation

1. Turn battery switch off and pull out applicable circuit breaker(s).
2. Position B144 instrument cluster on shell assembly's face plate and install screws. Verify security.
3. Install nuts securing console wiring to instrument cluster studs. Verify security.
4. Tilt console forward and install screws securing upper console to lower console. Verify security.
5. Install electronic flight display(s) per § 13-70, if removed.
6. Perform appropriate function checks per § 2.200.

E. Scheduled Maintenance and Inspections

Refer to § 2.400 100-Hour/Annual Inspection.

F. Special Maintenance and Inspections

1. Check continuity across two 3-amp fuses in B304-18 fuse assembly (at the ammeter shunt) and replace fuse assembly as required.
2. Inspect wiring for loose, chafed, frayed, or broken wires. Verify no damaged connectors. Verify wiring neatness, proper routing and installation, and security.
3. If ammeter is still inoperative, remove ammeter per Part C, and install airworthy ammeter per Part D.

13-32 Engine Oil Pressure Gage

A. Description

The engine oil pressure gage indicates engine oil pressure and receives its signal from a variable-resistor-type sender located in left-hand forward corner of engine compartment next to hourmeter pressure switch.

B. Schematic

Refer to Figure 14-21 for electrical schematic.

C. Removal

Remove instrument cluster per § 13-31 Part C.

D. Installation

Install instrument cluster per § 13-31 Part D.

E. Scheduled Maintenance and Inspections

Refer to § 2.400 100-Hour/Annual Inspection.

F. Special Maintenance and Inspections

1. Inspect wiring for loose, chafed, frayed, or broken wires. Verify no damaged connectors. Verify wiring neatness, proper routing and installation, and security.
2. Perform appropriate function checks per § 2.200. If accuracy of engine gage is suspected, remove instrument cluster per § 13-31 Part C, and return to RHC for inspection.
3. Install airworthy instrument cluster per § 13-31 Part D.

13-33 Engine Oil Temperature Gage

A. Description

The engine oil temperature gage indicates engine oil temperature and receives its signal from a probe mounted in the engine oil pressure screen housing or oil filter adapter.

B. Schematic

Refer to Figure 14-21 for electrical schematic.

C. Removal

Remove instrument cluster per § 13-31 Part C.

D. Installation

Install instrument cluster per § 13-31 Part D.

E. Scheduled Maintenance and Inspections

Refer to § 2.400 100-Hour/Annual Inspection.

F. Special Maintenance and Inspections

Perform special maintenance and inspections per § 13-32 Part F.

13-34 Cylinder Head Temperature Gage

A. Description

The cylinder head temperature gage indicates the temperature of cylinder #2 (O-540), cylinder #1, or #5 (IO-540) and receives its signal from a probe installed in the bottom of the cylinder head.

B. Schematic

Refer to Figure 14-21 for electrical schematic.

C. Removal

Remove instrument cluster per § 13-31 Part C.

D. Installation

Install instrument cluster per § 13-31 Part D.

E. Scheduled Maintenance and Inspections

Refer to § 2.400 100-Hour/Annual Inspection.

F. Special Maintenance and Inspections

Perform special maintenance and inspections per § 13-32 Part F.

13-35 Fuel Quantity Gages

A. Description

The fuel quantity gages indicate the fuel level of main and aux fuel tanks and receive signals from variable-resistance-type senders mounted on the bottom of each tank.

B. Schematic

Refer to Figure 14-21 for electrical schematic.

C. Removal

Remove instrument cluster per § 13-31 Part C.

D. Installation

Install instrument cluster per § 13-31 Part D.

E. Scheduled Maintenance and Inspections

Refer to § 2.400 100-Hour/Annual Inspection.

F. Special Maintenance and Inspections

Perform special maintenance and inspections per § 13-32 Part F.

13-36 Carburetor Air Temperature Gage (O-540)

A. Description

The carburetor air temperature gage is used to determine when carburetor heat is required during possible carburetor icing conditions, such as high humidity. Apply heat as required to keep needle out of yellow band. The carburetor air temperature gage should read approximately the same as the OAT gage when engine is cold.

B. Schematic

Refer to Figure 14-21 for electrical schematic.

C. Removal

Remove instrument cluster per § 13-31 Part C.

D. Installation

Install instrument cluster per § 13-31 Part D.

E. Scheduled Maintenance and Inspections

Refer to § 2.400 100-Hour/Annual Inspection.

F. Special Maintenance and Inspections

Perform special maintenance and inspections per § 13-32 Part F.

13-40 Additional Standard Indicating Equipment13-41 Clock**A. Description**

A manually set electric analog clock is standard equipment; a digital clock is optional.

B. Schematic

Refer to Figure 14-21 for electrical schematic.

C. Removal

1. Turn battery switch off.
2. a. Remove perimeter screws securing face to console and pull face aft.
b. Remove electronic flight display(s) per § 13-70, and remove screws securing upper console to lower console and tilt upper console aft.
3. Remove screws securing clock to face.
4. Disconnect console wiring from clock wiring at connectors, and remove clock.

D. Installation

1. Turn battery switch off.
2. Connect console wiring to clock wiring at connectors. Verify security.
3. Install screws securing clock to face. Verify security.
4. a. Install perimeter screws securing face to console and verify security.
b. Tilt console forward and install screws securing upper console to lower console and verify security; install electronic flight display(s) per § 13-70, if removed.
6. Perform appropriate function checks per § 2.200.

E. Scheduled Maintenance and Inspections

Refer to § 2.400 100-Hour/Annual Inspection.

F. Special Maintenance and Inspections

1. Check AGC-3 (3 amp) fuse at firewall for evidence of melting and replace fuse as required.
2. Inspect wiring for loose, chafed, frayed, or broken wires. Verify no damaged connectors. Verify wiring neatness, proper routing and installation, and security.
3. If clock is still inoperative, remove clock per Part C, and install airworthy clock per Part D.

13-42 Outside Air Temperature (OAT) Gage/Voltmeter

A. Description

NOTE

No cutting or splicing of OAT probe wires is permitted.

The outside air temperature indicator has a stainless steel probe protruding from chin of rotorcraft and is connected to gage by a calibrated length of cable.

B. Schematic

Refer to Figure 14-21 for electrical schematic.

C. Removal

1. Turn battery switch off.
2. Remove electronic flight display(s) per § 13-70, if installed.
3. Remove screws securing upper console to lower console and tilt upper console aft.
4. Remove screws securing OAT gage to face.
5. Disconnect console wiring from OAT gage wiring at connectors, and remove gage.

D. Installation

1. Turn battery switch off.
2. Connect console wiring to OAT gage wiring at connectors. Verify security.
3. Install screws securing OAT gage to face. Verify security.
4. Tilt console forward and install screws securing upper console to lower console. Verify security.
5. Install electronic flight display(s) per § 13-70, if removed.
6. Perform appropriate function checks per § 2.200.

E. Scheduled Maintenance and Inspections

Refer to § 2.400 100-Hour/Annual Inspection.

F. Special Maintenance and Inspections

1. Inspect wiring for loose, chafed, frayed, or broken wires. Verify no damaged connectors. Verify wiring neatness, proper routing and installation, and security.
2. If OAT gage is still inoperative, remove OAT gage per Part C, and install airworthy OAT gage per Part D.

13-43 Hourmeter**A. Description**

An hourmeter actuated by engine oil pressure and collective switch is located to the right of the pilot's seat.

B. Schematic

Refer to Figure 14-21 for electrical schematic.

C. Removal

1. Remove screws securing D830-2 hourmeter to C353-2 panel, right of the pilot's seat.
2. Disconnect airframe wiring from hourmeter and remove hourmeter.

D. Installation

1. Connect airframe wiring to hourmeter (C859-42 to positive terminal). Verify security.
2. Install screws securing D830-2 hourmeter to C353-2 panel, right of the pilot's seat. Verify security.

E. Scheduled Maintenance and Inspections

On condition.

F. Special Maintenance and Inspections

1. Inspect wiring for loose, chafed, frayed, or broken wires. Verify no damaged connectors. Verify wiring neatness, proper routing and installation, and security.
2. If hourmeter is still inoperative, remove hourmeter per Part C, and install airworthy hourmeter per Part D. Make appropriate maintenance record entries.

13-50 Senders and Sensors

13-51 Oil Temperature Senders

A. Description

A760-1 Oil temperature sender (single) is for use with the B144-3 (14V) or B144-4 (28V) instrument cluster. A760-3 oil temperature sender (dual) is for use with the B144-5 (10–32V) instrument cluster.

B. Schematic

Refer to Figure 14-21 for electrical schematic.

C. Removal

1. Remove left side engine cowling.
2. Turn battery switch off & pull out GOV (2 amp) circuit breaker on circuit breaker panel.
3. Using backup wrench, remove nut securing C049 harness assembly's wire terminal to A760 oil temperature sender stud.
4. Cut and discard lockwire securing sender to thermostatic oil cooler bypass valve. Remove sender from D723-1 adapter assembly.

D. Installation

1. Turn battery switch off & pull out GOV (2 amp) circuit breaker on circuit breaker panel.
2. Install gasket supplied with A760 oil temperature sender, and sender, in D723-1 adapter assembly. Special torque sender to 300 in.-lb and torque stripe per Figure 2-1. Safety sender to thermostatic oil cooler bypass valve using 0.032-inch diameter lockwire.
3. Attach C049 harness assembly's wire terminal to sender; using backup wrench, install nut securing wire terminal to sender. Special torque nut to 20 in.-lb and torque stripe per Figure 2-1.
4. Install left side engine cowling. Push in GOV (2 amp) circuit breaker on circuit breaker panel.

13-52 Cylinder Head Temperature (CHT) Senders

A. Description

A760-2 Cylinder head temperature sender is for use with the B144-5 (10–32V) instrument cluster. 3080-00038 cylinder head temperature probe is for use with the B144-3 (14V) or B144-4 (28V) instrument cluster.

B. Schematic

Refer to Figure 14-21 for electrical schematic.

C. Removal

1. Remove right or left side engine cowling, as applicable.
2. Turn battery switch off & pull out GOV (2 amp) circuit breaker on circuit breaker panel.
3. Using backup wrench, remove palnut and brass nut securing C049 harness assembly's -34 wire terminal to A760-2 or 3080-00038 cylinder head temperature sender/probe stud (one brass nut remains on stud). Discard palnut.
4. Remove sender/probe from cylinder head (O-540 without air conditioning: aft, RH [#2]; O-540 with air conditioning: forward, LH [#5]; IO-540: forward, LH [#5]).

D. Installation

1. Turn battery switch off & pull out GOV (2 amp) circuit breaker on circuit breaker panel.
2. Install gasket supplied with A760-2 or 3080-00038 cylinder head temperature sender/probe, and sender/probe, in cylinder head (O-540 without air conditioning: aft, RH [#2]; O-540 with air conditioning: forward, LH [#5]; IO-540: forward, LH [#5]). Special torque sender/probe to 75 in.-lb and torque stripe per Figure 2-1.
3. Calibrate cylinder head temperature gage per Part E, as required.
4. Attach C049 harness assembly's -34 wire terminal to sender/probe. Using backup wrench, install brass nut securing wire terminal to sender/probe; tighten nut. Install new B330-2 palnut; tighten palnut. Torque stripe per Figure 2-1.
5. Install engine cowling. Push in GOV (2 amp) circuit breaker on circuit breaker panel.

13-52 Cylinder Head Temperature (CHT) Senders (continued)

E. Calibration

NOTE

C691-1 Circuit board assembly must be installed on B144 instrument cluster to perform calibration. For earlier helicopters, order and install KI-249 CHT Gage Calibration Kit, as required (refer to R44 Service Letter SL-59).

1. Turn battery switch off and pull all circuit breakers.
2. Remove right or left side engine cowling, as applicable.
3. Using backup wrench, remove palnut and brass nut securing C049 harness assembly's -34 wire terminal to A760-2 or 3080-00038 cylinder head temperature sender/probe stud (one brass nut remains on stud). Discard palnut.
4. Open instrument console for access to back side of CHT gage in B144 instrument cluster.
5. Refer to Figure 13-2. Adjust resistance decade box to 32 ± 0.4 ohms and verify resistance with multimeter. Alternately, a 32.0 ± 0.4 ohm resistor may be used instead of decade box. Connect a low-impedance (< 1 ohm) test lead to one terminal on decade box and clamp opposite end of lead to hexagonal body of CHT probe; do not connect lead to center conductor of sender/probe. Connect -34 wire to remaining terminal on decade box.

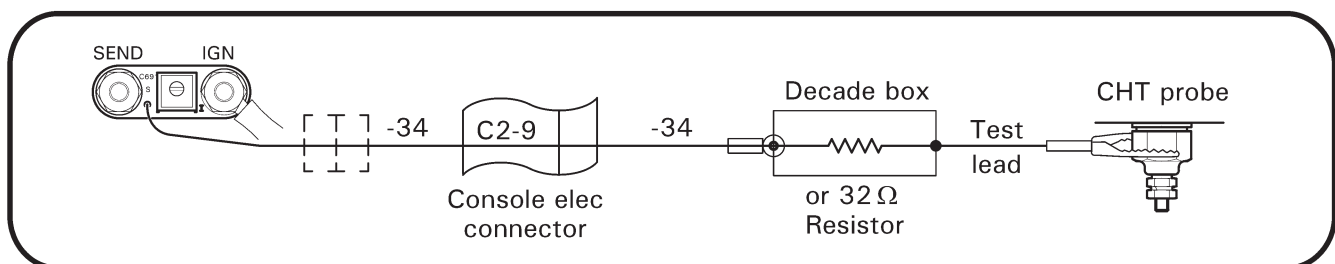

FIGURE 13-2 CYLINDER HEAT TEMPERATURE GAGE CALIBRATION

6. Refer to Figure 13-3. Push in GAGES 2-amp circuit breaker. Turn battery switch on and observe CHT gage. Adjust potentiometer screw on C691-1 circuit board assembly until gage indicates within limits shown with console in closed position (CHT probe resistance is 32 ± 0.4 ohms at 500° F).
7. Cut small square of A701-1 aluminum tape sized to fit potentiometer face. Apply tape to potentiometer and press tape tight against adjustment screw to prevent rotation (pressing with a pencil eraser works well). Verify CHT needle has not moved. If movement is noted, remove tape and repeat step 6 as required. Turn battery switch off.

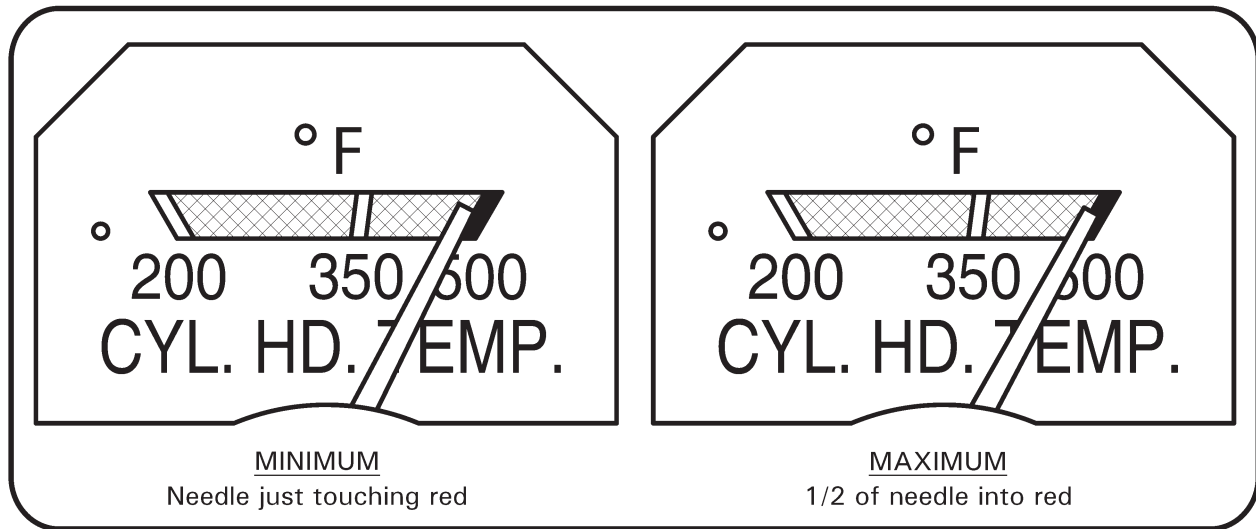

FIGURE 13-3 CYLINDER HEAT TEMPERATURE GAGE CALIBRATION

13-52 Cylinder Head Temperature (CHT) Senders (continued)

E. Calibration (continued)

8. Close and secure instrument console. Push in all remaining circuit breakers.
9. Attach C049 harness assembly's -34 wire terminal to sender/probe. Using backup wrench, install brass nut securing wire terminal to sender/probe; tighten nut. Install new B330-2 palnut; tighten palnut. Torque stripe per Figure 2-1.
10. Install engine cowling.

13-53 Outside Air Temperature (OAT) Senders

A. Description

The A760-4 OAT sender is the data input for the D270-1 governor/engine monitoring unit; the B341-4 OAT sender is the data input for the B341-1 OAT gage.

B. Schematic

Refer to Figure 14-21 for electrical schematic.

C. Removal

1. Turn battery switch off & pull out GOV (2 amp) circuit breaker on circuit breaker panel.
2. Remove forward belly panel.
3. Cut and discard ty-raps as required and disconnect A760-4 OAT wiring from airframe harness at connectors; remove hardware securing ground wire. Using backup wrench, remove nut and lockwasher securing sender probe to cabin.

D. Installation

1. Turn battery switch off & pull out GOV (2 amp) circuit breaker on circuit breaker panel.
2. Install lockwasher and nut securing A760-4 OAT sender probe to cabin. Using backup wrench, special torque nut to 18 in.-lb. Verify security.
3. Connect OAT sender wiring to airframe harness at connectors; install hardware securing ground wire. Verify security. Install ty-raps as required to securing wiring; cinch ty-raps until snug without overtightening and trim tips flush with heads.
4. Install forward belly panel. Push in GOV (2 amp) circuit breaker on circuit breaker panel.

13-54 Engine Tachometer Hall Effect Sensor Assembly

A. Schematic

Refer to Figure 14-21 for electrical schematic.

B. Removal

1. Turn battery switch off & pull out GOV (2 amp) circuit breaker on circuit breaker panel.
2. Remove engine left side cowling.
3. Cut and discard ty-raps as required and disconnect C143-2 hall effect sensor assembly wiring from airframe harness at connectors.
4. Remove engine-supplied hardware securing sensor assembly and engine-supplied gasket to engine; remove sensor assembly and gasket.

C. Installation

1. Turn battery switch off & pull out GOV (2 amp) circuit breaker on circuit breaker panel.
2. Install engine-supplied gasket and C143-2 hall effect sensor assembly on engine and install engine-supplied hardware. Special torque nuts to 96 in.-lb. Verify security.
3. Connect sensor assembly wiring to airframe harness at connectors and install ty-raps, as required. Cinch ty-raps until snug without overtightening and trim tips flush with heads.
4. Install engine left side cowling. Push in GOV (2 amp) circuit breaker on circuit breaker panel.

13-60 Instrument Markings

See R44, R44 II, or R44 Cadet Pilot's Operating Handbook (POH) Section 2 for instrument markings.

Intentionally Blank

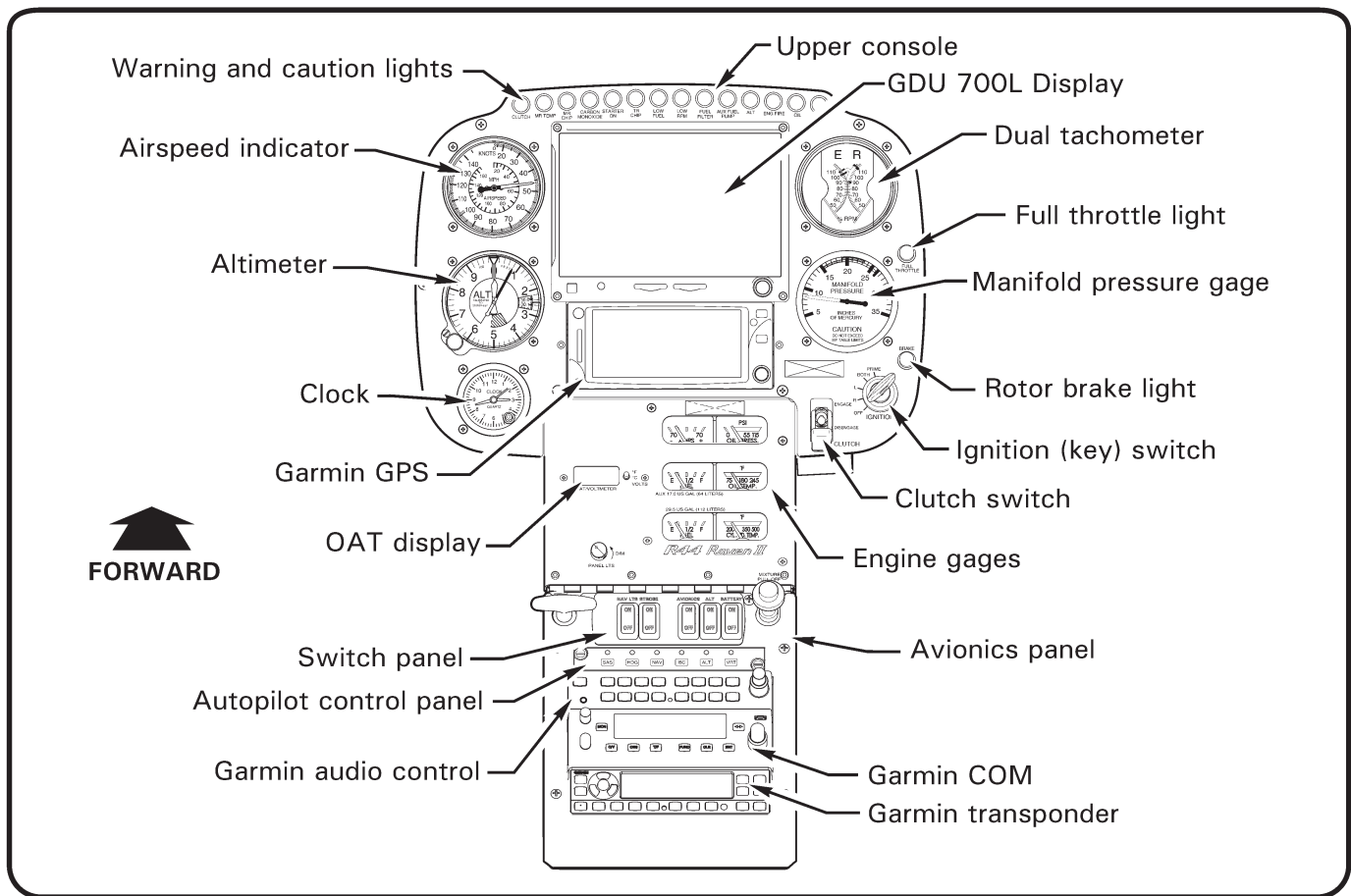

FIGURE 13-4 GARMIN G500H UPPER CONSOLE WITH GDU 700L (R44 II SHOWN)

13-70 Electronic Flight Displays

13-71 Garmin Display Unit (GDU) 700L

NOTE

Refer to Garmin G500H Instructions for Continued Airworthiness.

A. Description

The GDU 700L integrates with the Garmin G500H Electronic Flight Instrument System (EFIS). Similar to the GDU 620, the GDU 700L electronically displays primary flight instrumentation via a primary flight display (PFD) and moving map and other functionality via a multifunction display (MFD), but includes touch-screen technology on one 7 inch display.

Refer to § 38-10 for Garmin G500H EFIS system components.

B. Schematics

Refer to Figure 14-36 for GDU 700L installation electrical schematic.

Refer to Figures 13-1, 13-5 (STD), & 13-6 (Floats) for Garmin G500H upper console pitot-static schematic.

13-71 Garmin Display Unit (GDU) 700L (continued)**C. Removal**

1. Turn battery & avionics switches off and pull out EFIS circuit breaker (5 amp) at panel.
2. Remove screws securing GDU display to console face.
3. Pull out and support display, unplug console harness connectors, and remove display.

D. Installation

1. Turn battery & avionics switches off and pull out EFIS circuit breaker (5 amp) at panel.
2. Visually inspect console harness connectors and verify no bent or damaged pins. Support display and plug in console harness connectors.
3. Place GDU display in console, then install and tighten screws. Verify security.
4. Push in EFIS circuit breaker at panel. Turn battery & avionics switches on.

NOTE

Refer to R44 Service Letter SL-57A. There is no continuing airworthiness requirement to check or update avionics software levels. Software updates should not be attempted without a thorough understanding of approval status and compatibility.

5. Perform appropriate functional checks per Garmin G500H Instructions for Continued Airworthiness. Turn battery & avionics switches off.

E. Scheduled Maintenance and Inspections

Refer to Garmin G500H Instructions for Continued Airworthiness.

F. Special Maintenance and Inspections

1. Remove GDU per Part C.
2. Open circuit breaker panel and upper console.
3. Inspect condition of and verify no obvious damage to GDU, copper bus bars, circuit breaker, and wiring. Verify no loose, chafed, or broken wires or terminals. Verify no evidence of arcing. Verify installed equipment security.
4. Secure circuit breaker panel and upper console.
5. Install GDU per Part D.

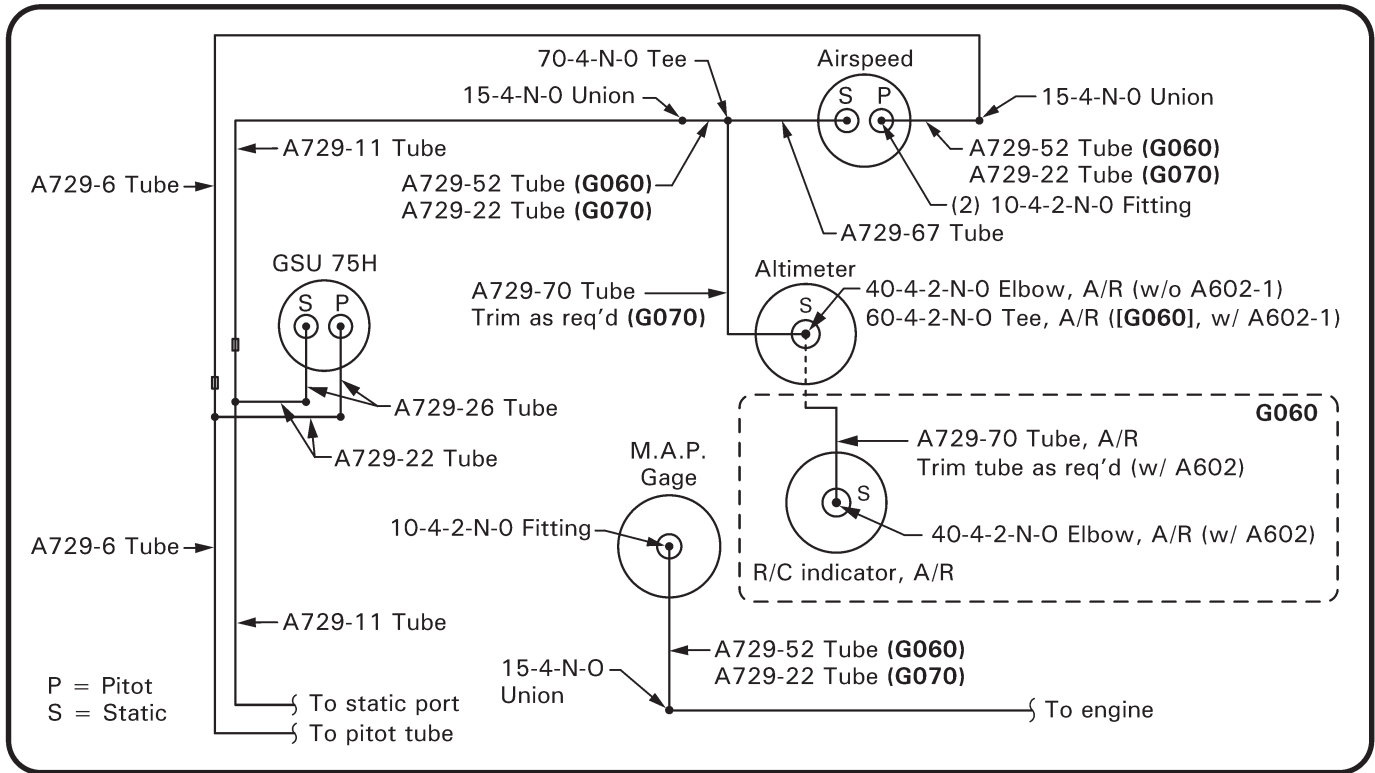

FIGURE 13-5 GARMIN G500H UPPER CONSOLE PITOT-STATIC SCHEMATIC (STD)

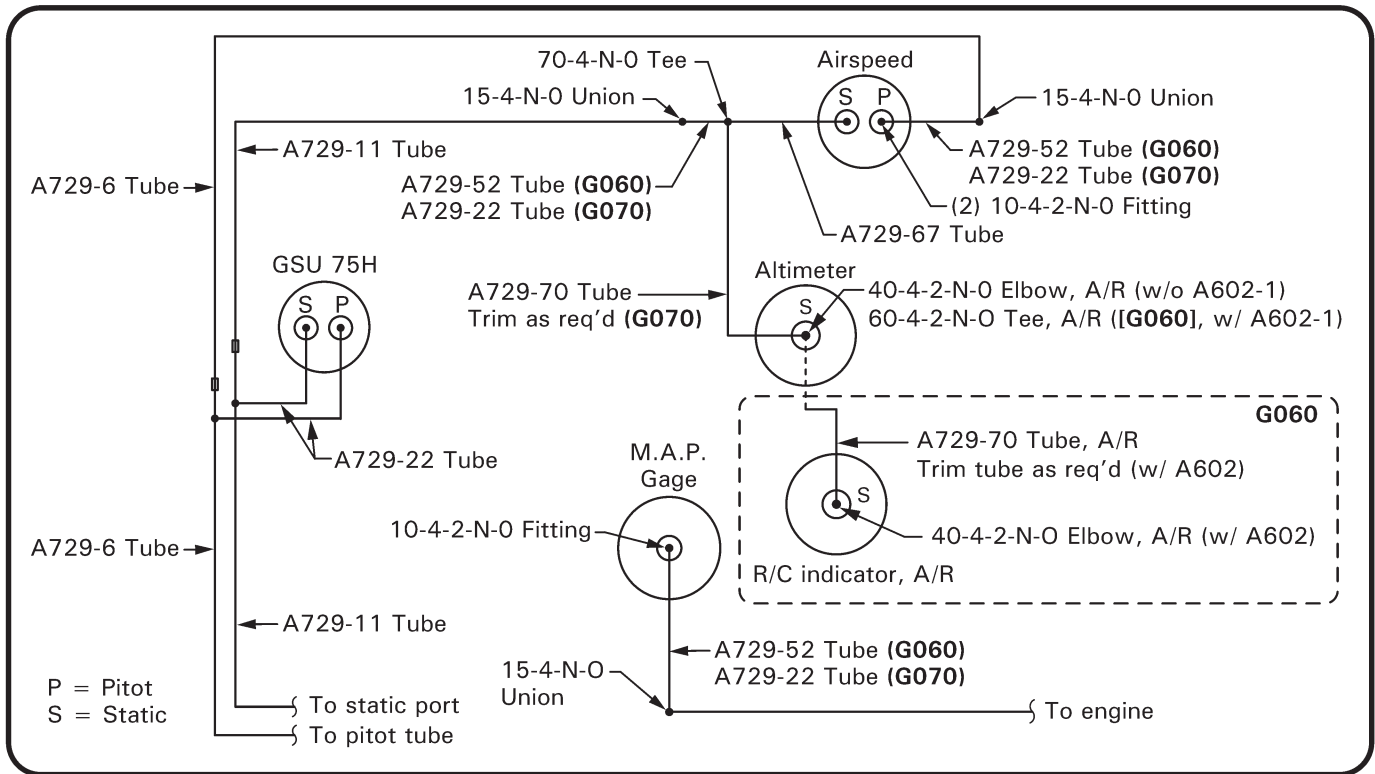

FIGURE 13-6 GARMIN G500H UPPER CONSOLE PITOT-STATIC SCHEMATIC (FLOATS)

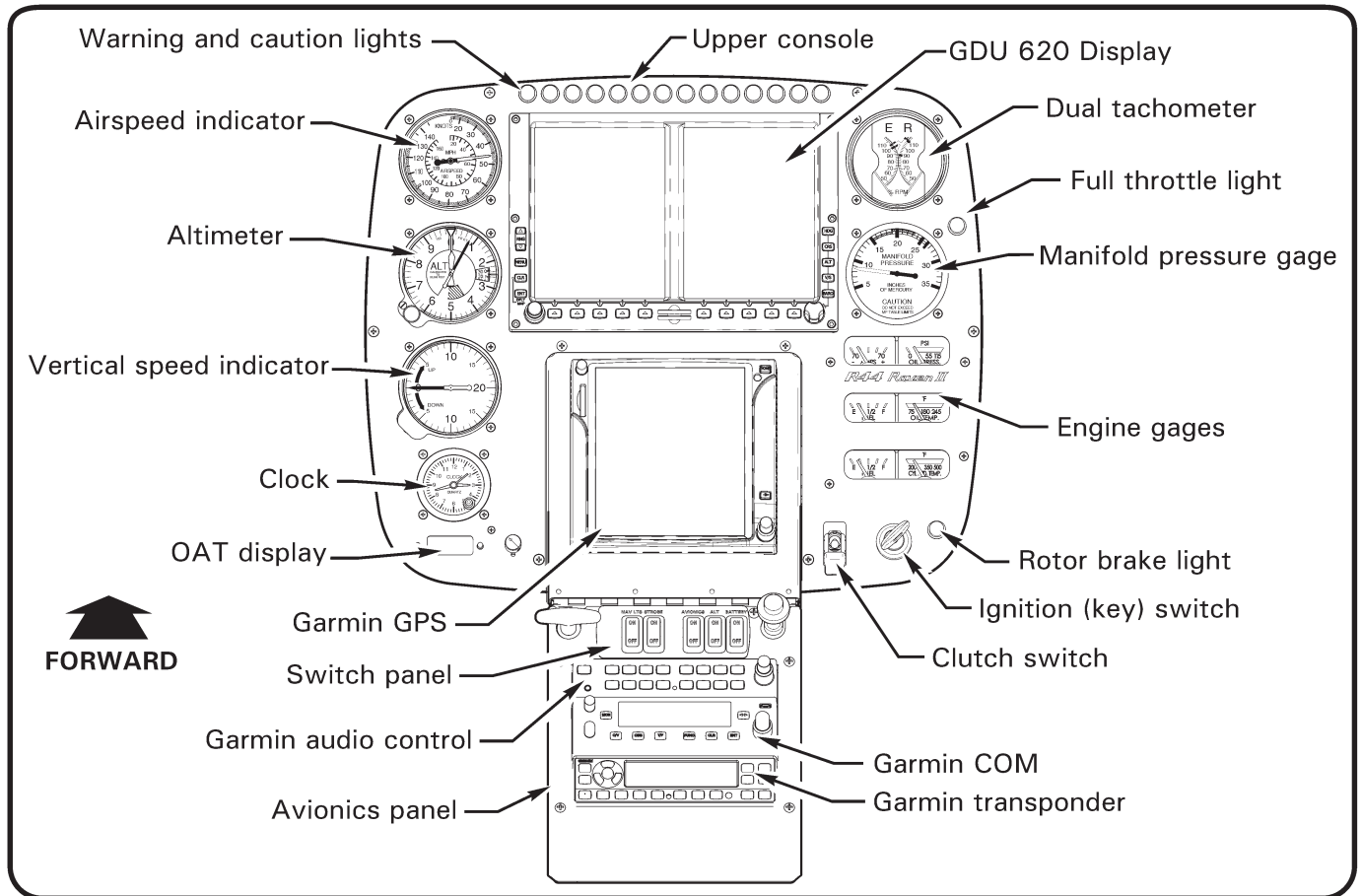

FIGURE 13-7 GARMIN G500H UPPER CONSOLE WITH GARMIN GDU 620 DISPLAY (R44 II SHOWN)

13-72 Garmin Display Unit (GDU) 620

NOTE
Refer to Garmin G500H Instructions for Continued Airworthiness.

A. Description

The GDU 620 integrates with the Garmin G500H Electronic Flight Instrument System (EFIS). The GDU 620 electronically displays primary flight instrumentation via a primary flight display (PFD) and moving map, weather, traffic, terrain and other functionality via a multifunction display (MFD) on dual 6.5 inch displays.

Refer to § 38-10 for Garmin G500H EFIS system components.

B. Schematics

Refer to Figure 14-35 for GDU 620 installation electrical schematic.

Refer to Figures 13-1, 13-5 (STD), & 13-6 (Floats) for Garmin G500H upper console pitot-static schematic.

13-72 Garmin Display Unit (GDU) 620 (continued)**C. Removal**

Remove GDU per § 13-71 Part C.

D. Installation

Install GDU per § 13-71 Part D.

E. Scheduled Maintenance and Inspections

Refer to Garmin G500H Instructions for Continued Airworthiness.

F. Special Maintenance and Inspections

Refer to § 13-71 Part F.

Intentionally Blank

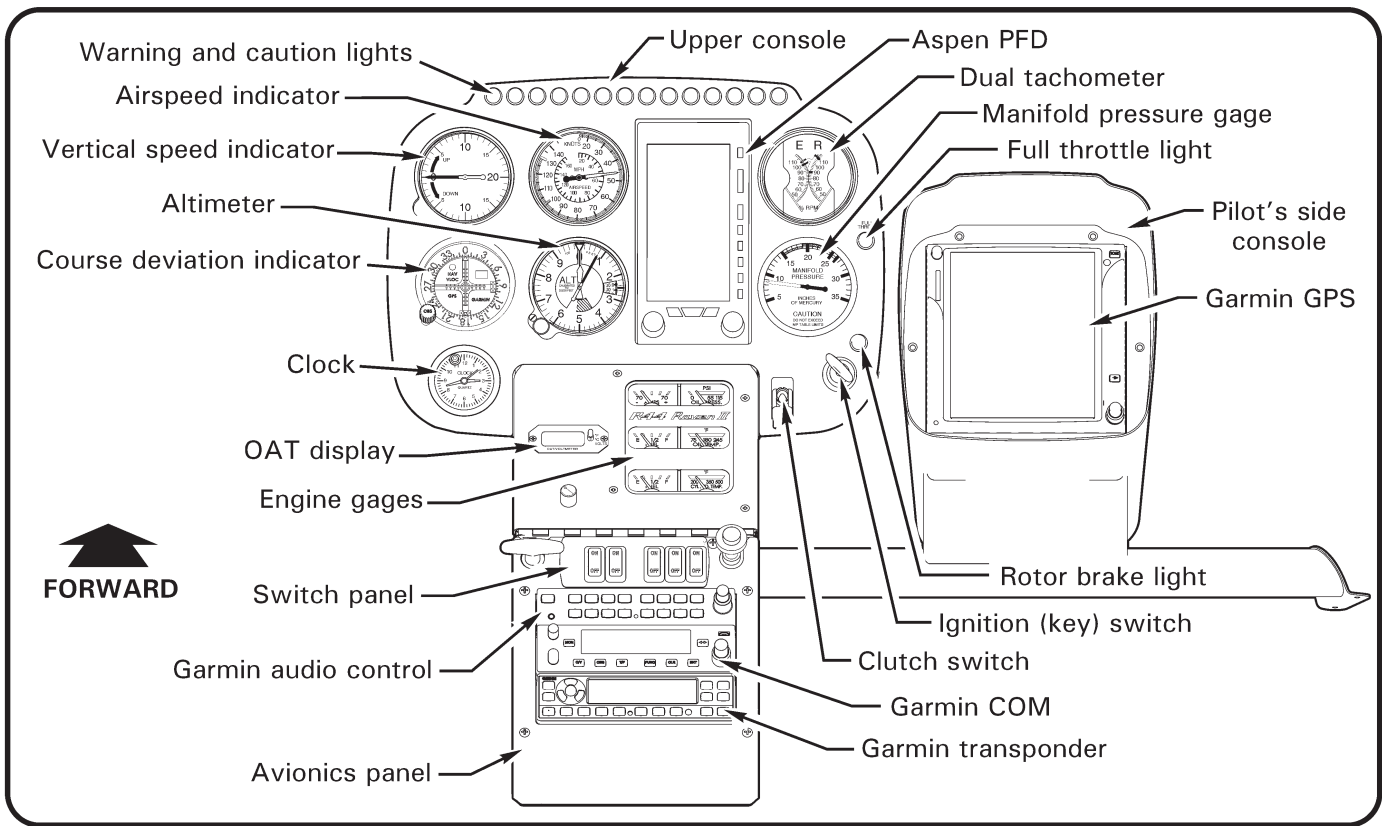

FIGURE 13-8 EIGHT-INSTRUMENT CONSOLE WITH ASPEN PFD - TYPICAL (R44 II SHOWN)

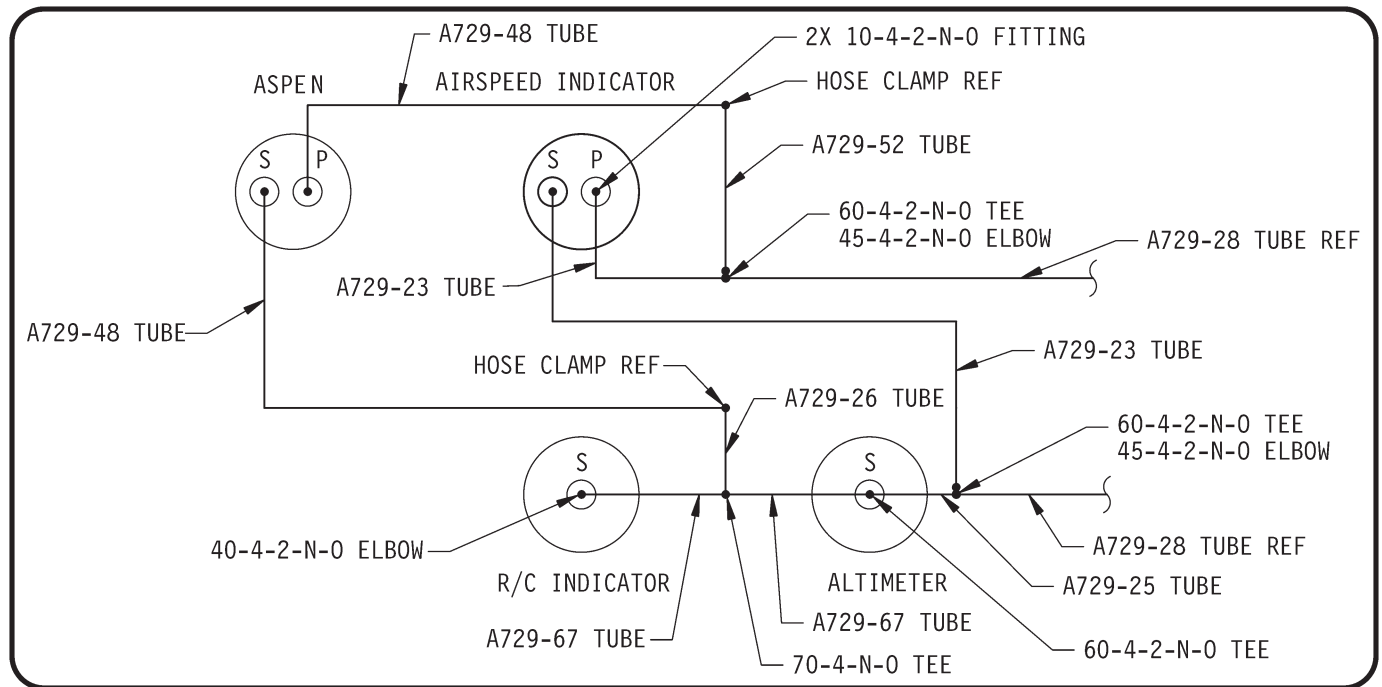

FIGURE 13-9 EIGHT-INSTRUMENT CONSOLE WITH ASPEN PFD PITOT-STATIC SCHEMATIC

13-73 Aspen EFD500H & EFD1000H Display(s)

A. Description

R44 options include a single screen Aspen PFD, or a dual-screen Aspen PFD and MFD.

The Aspen PFD (Primary Flight Display) is an LCD unit with displays for attitude, altitude, airspeed, heading, and optional NAV (HSI/CDI). The Aspen PFD is a situational awareness aid, to be used in conjunction with required VFR instruments (altimeter, airspeed indicator, and magnetic compass).

The standard Aspen PFD installation configures the lower half of the display as a directional gyro. An optional installation configures the lower half of the display to a Horizontal Situation Indicator (HSI). Primary GPS position data is provided by GTN-series GPS. Heading and outside air temperature data is received from the Aspen remote sensor module (RSM). The RSM provides backup GPS position data if primary GPS fails.

The Aspen MFD (Multifunction Display) is an LCD unit with displays for moving map navigation data, terrain, and traffic. Terrain and traffic may also be overlaid on moving map. GPS position data is provided by Garmin GTN-series GPS for moving map and terrain displays. Aspen MFD also includes an internal terrain database. TIS-A traffic data may be received from Garmin GTX330 transponder for moving map display.

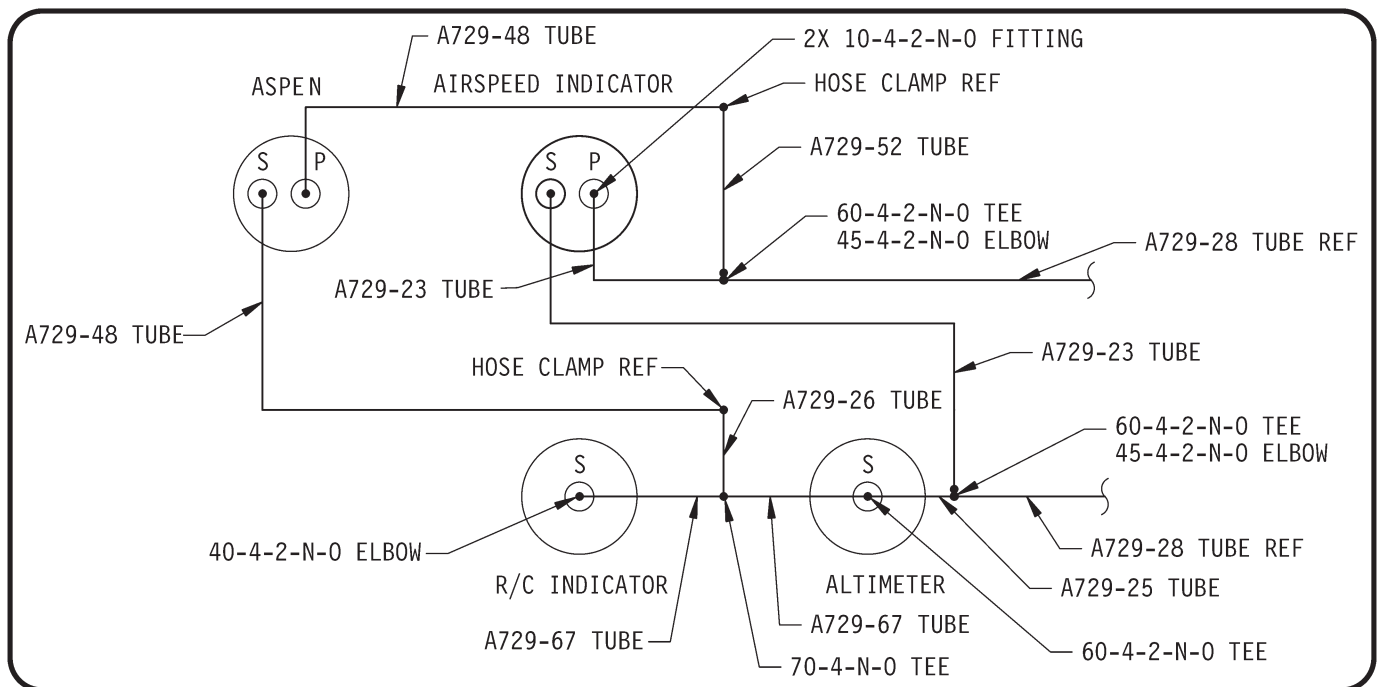

FIGURE 13-10 SIX-INSTRUMENT CONSOLE WITH ASPEN PFD PITOT-STATIC SCHEMATIC

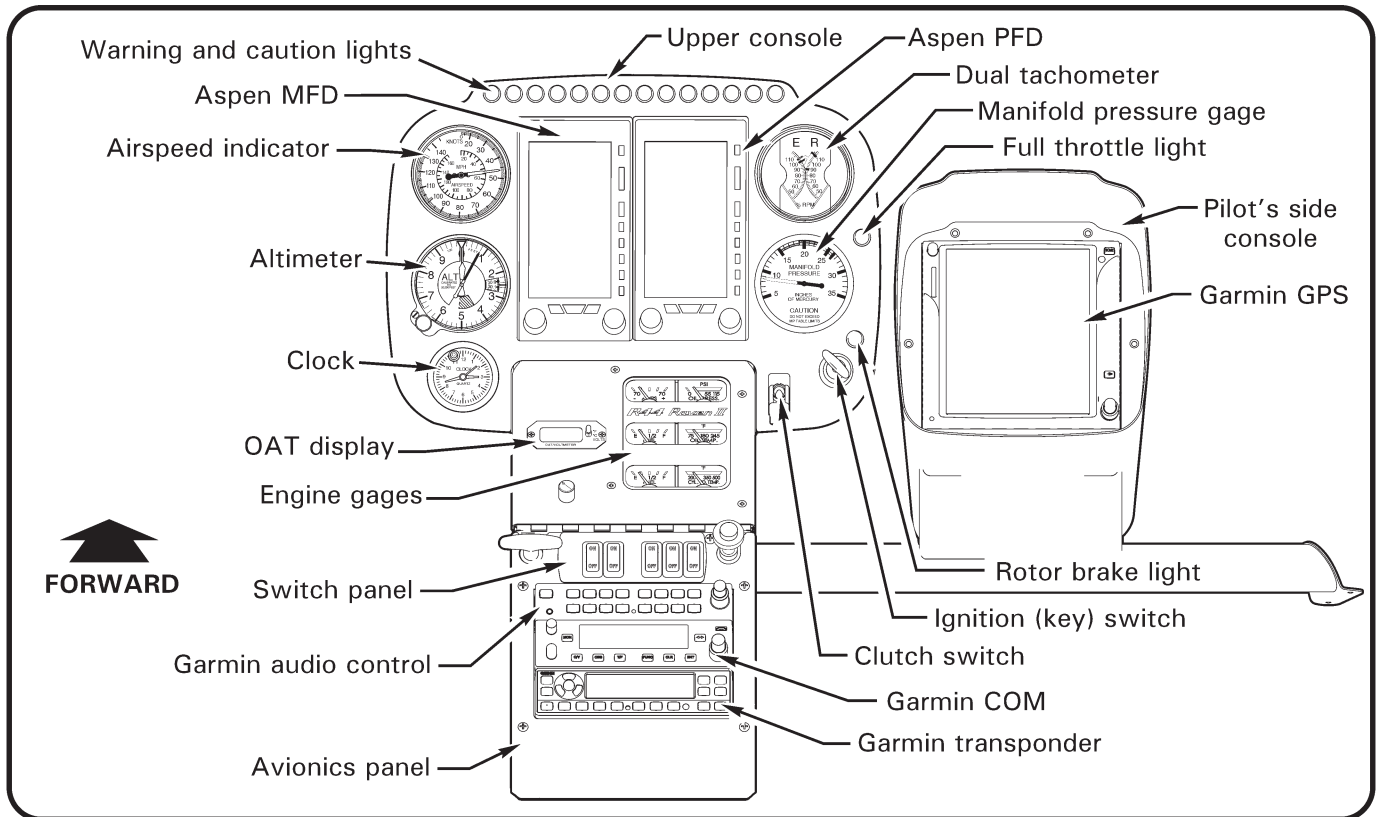

FIGURE 13-11 EIGHT-INSTRUMENT CONSOLE WITH ASPEN PFD AND MFD – TYPICAL (R44 II SHOWN)

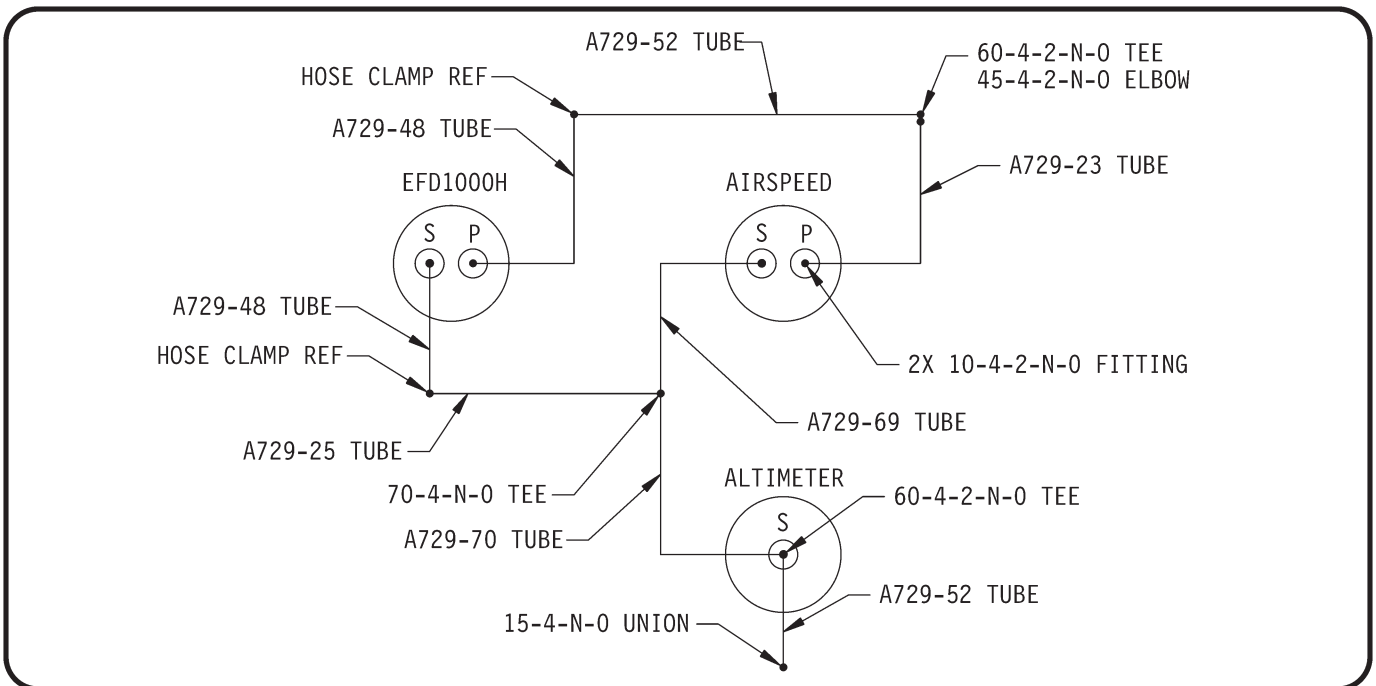

FIGURE 13-12 EIGHT-INSTRUMENT CONSOLE WITH ASPEN PFD AND MFD PITOT-STATIC SCHEMATIC

13-73 Aspen EFD500H & EFD1000H Display(s) (continued)**B. Schematics**

Refer to Figure 14-23 for C800-1 Aspen PFD electrical schematic, and Figure 14-24 for C800-3 Aspen PFD and MFD electrical schematic.

Refer to Figures 13-1, 13-9, & 13-10 for Aspen PFD pitot-static schematic, and Figures 13-1 and 13-12 for Aspen PFD and MFD pitot-static schematic.

C. Removal

1. Turn battery switch off and pull-out EFIS circuit breaker (7.5 amp) at panel.
2. Gently depress blue tab(s) at top of Aspen PFD/MFD to release display(s) from mounting bracket(s).
3. PFD only: Disconnect pitot and static lines from display using quick-disconnect couplers. Temporarily cap pitot and static line fittings at display and in aircraft to prevent contamination.
4. Loosen screws securing airframe wiring harness connector(s) to display(s), unplug connector(s), and remove display(s).

D. Installation

1. Turn battery switch off and pull-out EFIS circuit breaker (7.5 amp) at panel.
2. Plug airframe wiring harness connector(s) into Aspen PFD/MFD display(s) and tighten screws. Verify security.
3. PFD only: Remove temporary fitting caps and connect pitot and static lines to display using quick-disconnect couplers.
4. Insert display(s) into mounting bracket(s) until blue tab(s) snap(s) into place. Verify security.
5. Push-in EFIS circuit breaker (7.5 amp) at panel. Turn battery & avionics switches on.
6. Perform appropriate functional checks per Aspen EFD1000H PFD / EFD500H MFD Pilot's Guide. Turn battery and avionics switches off.
7. Perform pitot-static leak check.

13-73 Aspen EFD500H & EFD1000H Display(s) (continued)**E. Remote Sensor Module (RSM) Antenna****NOTE**

Do not use magnetized tools.

Removal

1. Turn battery switch off and pull-out EFIS circuit breaker (7.5 amp) on circuit breaker panel.
2. Refer to § 16-70 for antenna locations. Using plastic scraper, remove B270-1 sealant from around EFIS antenna at corners where it attaches to tailcone.
3. Cut and discard ty-raps as required and disconnect antenna cable at connectors (secured to frame). Remove screws securing antenna and antenna ground wire to tailcone and remove antenna.

Installation

1. Turn battery switch off and pull-out EFIS circuit breaker (7.5 amp) on circuit breaker panel.
2. Remove paint & primer from antenna and antenna ground wire mating surfaces to ensure electrical ground.
3. Install screws securing antenna and antenna ground wire to tailcone. Verify security.
4. Apply small bead B270-1 sealant (0.1 inch max in height) around antenna at corners where it attaches to tailcone and allow to dry.
5. Connect antenna cable at connectors; secure to frame using ty-raps. Verify security.
6. Perform ground checks per Part D steps 5 and 6.

F. Scheduled Maintenance and Inspections

Maintenance is on condition. Contact Aspen Avionics at www.aspenavionics.com for instructions for continued airworthiness.

NOTE

Refer to § 38-60 for avionics software information.

G. Special Maintenance and Inspections

1. Turn battery and avionics switches off. Open circuit breaker panel and upper console.
2. Inspect condition of and verify no obvious damage to Aspen displays, pitot-static lines, metal braiding, copper bus bars, circuit breaker, and wiring. Verify no loose, chafed, or broken wires or terminals. Verify no evidence of arcing. Verify equipment security.
3. Secure circuit breaker panel and upper console. Perform ground checks per Part D steps 5 and 6.

13-80 Console Assemblies

NOTE

Refer to applicable Pilot's Operating Handbook Section 7 for views of typical instrument panels, and the Optional Avionics Supplement for views of panels with electronic flight displays.

A. Opening Console

Upper instrument panels that do not include Electronic Flight Displays (EFDs) or other avionics may be "opened" by removing screws securing console assembly to forward keel panels and hinging console aft. Secure console by hinging forward and installing screws. If an EFD or any other avionics are installed in the upper instrument panel, remove console per Part B.

B. Removing Console

1. Remove EFD if installed per § 13-70.
2. Remove avionics if installed and located in upper instrument console per Chapter 38.
3. Remove HeliSAS control panel if installed and located in upper instrument console (not required if control panel is located at top of avionics stack).
4. Remove perimeter screws securing instrument face to console.
5. Disconnect instrument pitot-static lines. Plug lines.
6. Remove screws securing console assembly to forward keel panels and lower panel. Remove console and disconnect console harness from airframe harness.

C. Installing Console

1. Connect console assembly harness to airframe harness and install screws securing console to forward keel panels and lower panel.
2. Position instrument face in helicopter, remove plugs, and connect pitot-static lines.
3. Install perimeter screws securing face to console. Verify security.
4. Install HeliSAS control panel, if removed.
5. Install avionics per Chapter 38, if removed.
6. Install EFD per § 13-70, if removed.
7. Perform pitot-static system leak check per § 13-10.

Intentionally Blank

CHAPTER 14

ELECTRICAL AND AVIONICS SYSTEMS

<u>Section</u>	<u>Title</u>	<u>Page</u>
14.000	Electrical and Avionics Systems	14.1
14.300	Police and Electronic News Gathering (E.N.G.) Version Equipment	14.3
14.310	(Nucomm) HD Microwave System	14.3A
14.311	(Nucomm) HD Microwave System — Controller	14.3A
14.312	(Nucomm) HD Microwave System — Transmitter	14.3A
14.313	(Nucomm) HD Microwave System — Pod Antenna	14.3B
14.314	(Nucomm) HD Microwave System — Power Amp	14.3B
14.320	(Vislink) HD Microwave System	14.3C
14.321	(Vislink) HD Microwave System — Control Panel	14.3C
14.322	(Vislink) HD Microwave System — L1600 Encoder Transmitter	14.3C
14.323	(Vislink) HD Microwave System — Pod Antenna	14.3D
14.324	(Vislink) HD Microwave System — Power Amp	14.3D
14.330	Geneva Audio System	14.3E
14.331	Geneva Audio System — Pilot Audio Panel	14.3E
14.332	Geneva Audio System — Co-pilot Audio Panel	14.3E
14.333	Geneva Audio System — Aft Audio Panels	14.3F
14.334	Geneva Audio System — Router	14.3G
14.335	Geneva Audio System — Transmit Switch	14.3I
14.600	Electrical System Schematics	14.17
14.700	[Reserved.]	14.21
14.800	Antenna Locations	14.25
14.900	Avionics Schematics	14.27

Intentionally Blank

CHAPTER 14**ELECTRICAL AND AVIONICS SYSTEMS**14.000 Electrical and Avionics Systems

Electrical System information has been moved to Chapter 37.

Avionics information has been moved to Chapter 38.

[Pages 14.3J thru 14.16 have been deleted, are no longer effective, and should be discarded.]

Intentionally Blank

Intentionally Blank

14.300 Police and Electronic News Gathering (E.N.G.) Version Equipment

14.310 (Nucomm) HD Microwave System

Refer to R44 Illustrated Parts Catalog (IPC) Figures 90-21 and 90-27. Refer to MM Figures 14-3H, 14-3I, 14-3J, and 14-3K for microwave system installation wiring schematic.

14.311 (Nucomm) HD Microwave System - Controller

A. Removal

1. Turn battery switch off & pull-out associated circuit breaker.
2. Remove screws and washers securing ARC-CM-TX-RX-CR-01 controller to aft console. Carefully lift controller from console.
3. Loosen screws securing D-sub connector to controller receptacle and disconnect connector from controller. Remove controller.

B. Installation

1. Turn battery switch off & pull-out associated circuit breaker.
2. Position ARC-CM-TX-RX-CR-01 controller above aft console support and connect D-sub connector to controller receptacle. Tighten connector screws and verify security.
3. Position controller in support and install mounting washers and screws. Verify security.
4. Push-in associated circuit breaker & turn battery switch on. Perform appropriate post-installation function checks. Turn battery switch off.

14.312 (Nucomm) HD Microwave System - Transmitter

A. Removal

1. Turn battery switch off & pull-out associated circuit breaker.
2. Disconnect cable plugs from CMTX7-LITE transmitter.
3. Remove screws securing D429-12 angles and cable clamps to seat support and transmitter. Remove transmitter.

B. Installation

1. Turn battery switch off & pull-out associated circuit breaker.
2. Install screws securing D429-12 angles and cable clamps to seat support and CMTX7-LITE transmitter. Verify transmitter security.
3. Connect cable plugs to transmitter.
4. Push-in associated circuit breaker & turn battery switch on. Perform appropriate post-installation function checks. Turn battery switch off.

14.313 (Nucomm) HD Microwave System - Pod Antenna**A. Removal**

1. Turn battery switch off & pull-out associated circuit breaker.
2. Disconnect cable plugs from PA8- or PA16- pod antenna and D618-1 amp assembly.
3. Have a second person support pod antenna. Remove screws and washers securing pod antenna to D586 brackets, and remove pod antenna.
4. Remove power amp per Section 14.314.

B. Installation

1. Turn battery switch off & pull-out associated circuit breaker.
2. Have a second person support PA8- or PA16- pod antenna. Install screws and washers securing pod antenna to D586 brackets. Verify pod antenna security.
3. Connect cable plugs to pod antenna.
4. Push-in associated circuit breaker & turn battery switch on. Perform appropriate post-installation function checks. Turn battery switch off.

14.314 (Nucomm) HD Microwave System - Power Amp**A. Removal**

1. Turn battery switch off & pull-out associated circuit breaker.
2. Remove pod antenna per Section 14.313, as required, or disconnect cable plugs from amp assembly.
3. Remove screws securing amp assembly to PA8- or PA16- pod antenna, and remove amp and thermal pads.

B. Installation

1. Turn battery switch off & pull-out associated circuit breaker.
2. Align thermal pads, amp assembly, and PA8- or PA16- pod antenna fastener holes and install screws. Verify amp security.
3. Install pod antenna per Section 14.313, as required, or connect cable plugs to amp assembly.
4. Push-in associated circuit breaker & turn battery switch on. Perform appropriate post-installation function checks. Turn battery switch off.

14.320 (Vislink) HD Microwave System

Refer to R44 Illustrated Parts Catalog (IPC) Figures 90-23 and 90-27. Refer to MM Figures 14-3H, 14-3I, 14-3J, and 14-3K for microwave system installation wiring schematic.

14.321 (Vislink) HD Microwave System - Control Panel

A. Removal

1. Turn battery switch off & pull-out associated circuit breaker.
2. Remove screws and washers securing L1260 control panel to aft console. Carefully lift control panel from console.
3. Loosen screws securing D-sub connector to control panel receptacle and disconnect connector from control panel. Remove controller.

B. Installation

1. Turn battery switch off & pull-out associated circuit breaker.
2. Position L1260 control panel above aft console support and connect D-sub connector to control panel receptacle. Tighten connector screws and verify security.
3. Position control panel in support and install mounting washers and screws. Verify security.
4. Push-in associated circuit breaker & turn battery switch on. Perform appropriate post-installation function checks. Turn battery switch off.

14.322 (Vislink) HD Microwave System - L1600 Encoder Transmitter

A. Removal

1. Turn battery switch off & pull-out associated circuit breaker.
2. Disconnect cable plugs from L1600 encoder transmitter.
3. Remove screws securing transmitter to seat support, and remove transmitter.

B. Installation

1. Turn battery switch off & pull-out associated circuit breaker.
2. Install screws securing L1600 encoder transmitter to seat support. Verify transmitter security.
3. Connect cable plugs to transmitter.
4. Push-in associated circuit breaker & turn battery switch on. Perform appropriate post-installation function checks. Turn battery switch off.

14.322 (Vislink) HD Microwave System - HDT-1000 Encoder Transmitter**A. Removal**

1. Turn battery switch off & pull-out associated circuit breaker.
2. Disconnect cable plugs from HDT-1000 encoder transmitter.
3. Remove hardware securing transmitter to D429-13 plate, and remove transmitter.

B. Installation

1. Turn battery switch off & pull-out associated circuit breaker.
2. Install hardware securing HDT-1000 transmitter to D429-13 plate. Verify transmitter security.
3. Connect cable plugs to transmitter.
4. Push-in associated circuit breaker & turn battery switch on. Perform appropriate post-installation function checks. Turn battery switch off.

14.323 (Vislink) HD Microwave System - Pod Antenna

Perform pod antenna removal and installation per Section 14.313.

14.324 (Vislink) HD Microwave System - Power Amp

Perform power amp removal and installation per Section 14.314.

14.330 Geneva Audio System

Refer to MM Figures 14-3L and 13-3M for geneva audio system installation wiring schematic.

14.331 Geneva Audio - Pilot Audio Panel

Refer to R44 Illustrated Parts Catalog (IPC) Figure 92-21.

A. Removal

1. Turn battery switch off & pull-out associated circuit breaker.
2. Remove screws securing D579-8 audio panel to radio tray, and remove audio panel.

B. Installation

1. Turn battery switch off & pull-out associated circuit breaker.
2. Position D579-8 audio panel in appropriate radio tray support and install two mounting screws. Verify security.
3. Push-in associated circuit breaker & turn battery switch on. Perform appropriate post-installation function checks. Turn battery switch off.

14.332 Geneva Audio System - Co-pilot Audio Panel

Refer to R44 Illustrated Parts Catalog (IPC) Figure 92-23.

A. Removal

1. Turn battery switch off & pull-out associated circuit breaker.
2. Remove screws securing D557-2 cover to D592-1 mount and D579-7 audio panel. Remove cover.
3. Remove screws securing mount to FM transceiver and cabin structure.
4. Loosen screws securing D-sub connector to audio panel receptacle and disconnect connector from audio panel.
5. Remove audio panel. Remove screws securing mount to audio panel and remove mount.

14.332 Geneva Audio System - Co-pilot Audio Panel (continued)**B. Installation**

1. Turn battery switch off & pull-out associated circuit breaker.
2. Position D592-1 mount on D579-7 audio panel and install screws. Verify mount security.
3. Position audio panel in helicopter and connect D-sub connector to audio panel receptacle. Tighten connector screws and verify security.
4. Install screws securing mount to FM transceiver and cabin structure. Verify audio panel security.
5. Install screws securing D557-2 cover on audio panel. Verify cover security.
6. Push-in associated circuit breaker & turn battery switch on. Perform appropriate post-installation function checks. Turn battery switch off.

14.333 Geneva Audio System - Aft Audio Panels

Refer to R44 Illustrated Parts Catalog (IPC) Figure 92-25.

A. Removal

1. Turn battery switch off & pull-out associated circuit breaker.
2. Remove screws securing D579-7 or D579-9 audio panel to aft console. Carefully lift audio panel from console.
3. Loosen screws securing D-sub connector to audio panel receptacle and disconnect connector from audio panel. Remove audio panel.
4. Remove screws securing molding to audio panel and remove molding.

B. Installation

1. Turn battery switch off & pull-out associated circuit breaker.
2. Position molding on D579-7 or D579-9 audio panel and install screws. Verify molding security.
3. Position audio panel above appropriate aft console support and connect D-sub connector to audio panel receptacle. Tighten connector screws and verify security.
4. Position audio panel in support and install two mounting screws. Verify security.
5. Push-in associated circuit breaker & turn battery switch on. Perform appropriate post-installation function checks. Turn battery switch off.

14.334 Geneva Audio System - Router

Refer to R44 Illustrated Parts Catalog (IPC) Figure 92-27 and 92-31.

A. G13000 Digital Router Removal

1. Turn battery switch off & pull-out associated circuit breaker.
2. Hinge forward left seat forward.
3. Loosen screws securing D-sub connectors and ground wires to G13000 digital router receptacles and disconnect connectors from router. Remove audio panel.
4. Remove screws, washers, and spacers securing router to cabin floor. Remove router.

B. G13000 Digital Router Removal Installation

1. Turn battery switch off & pull-out associated circuit breaker.
2. Hinge forward left seat forward.
3. Position G13000 digital router on cabin floor and install spacers, washers, and screws. Verify router security.
4. Connect appropriate D-sub connectors and ground wires to router receptacles. Tighten connector screws and verify security.
5. Position audio panel in support and install two mounting screws. Verify security.
6. Hinge forward left seat aft. Push-in associated circuit breaker & turn battery switch on. Perform appropriate post-installation function checks. Turn battery switch off.

C. D579-2 Backplane Router Removal

1. Turn battery switch off & pull-out associated circuit breaker.
2. Hinge forward left seat forward. Cut and discard ty-raps as required to disconnect C060-5 transmit switch wiring from harness at connectors.
3. Loosen screws securing exterior D-sub connectors and ground wires to D579-2 backplane router and disconnect connectors from router.
4. Remove screw securing #1140 wire to router case. Remove screws securing three covers to router case, to access interior wire connectors.
5. Loosen screws securing interior D-sub connectors to router and disconnect connectors from router. Move harness to the side.
6. From helicopter belly, remove screws and washers securing router to floor. Lift router up and out of seat compartment.

14.334 Geneva Audio System - Router (continued)**D. D579-2 Backplane Router Installation**

1. Turn battery switch off & pull-out associated circuit breaker.
2. Hinge forward left seat forward.
3. Position D579-2 backplane router in seat compartment. From helicopter belly, install screws and washers securing router to floor. Verify security.
4. If not previously accomplished, remove screws securing three covers to router case, to access interior wire connectors.
5. Connect appropriate D-sub connectors to router interior receptacles. Tighten connector screws and verify security.
6. Install screws securing three covers to router case. Install screw securing #1140 wire to router case.
7. Connect appropriate D-sub connectors to router exterior receptacles. Tighten connector screws and verify security.
8. Connect C060-5 transmit switch wiring to harness at connectors and install ty-raps as required. Cinch ty-raps until snug without over-tightening, and trim tips flush with heads.
9. Hinge forward left seat forward. Push-in associated circuit breaker & turn battery switch on. Perform appropriate post-installation function checks. Turn battery switch off.

14.335 Geneva Audio - Transmit Switch

Refer to R44 Illustrated Parts Catalog (IPC) Figure 92-29.

A. Removal

1. Turn battery switch off & pull-out associated circuit breaker.
2. Unplug B121-1 transmit switch assembly from seat support. Hinge forward left seat forward.
3. Cut and discard ty-raps as required to disconnect transmit switch wiring from harness at connectors.
4. Remove hardware securing C060-5 transmit switch assembly to seat support, and remove switch assembly.

B. Installation

1. Turn battery switch off & pull-out associated circuit breaker.
2. Hinge forward left seat forward.
3. Position C060-5 transmit switch assembly against seat support and install hardware. Verify switch security.
4. Connect switch assembly wiring to harness at connectors and install ty-raps as required. Cinch ty-raps until snug without over-tightening, and trim tips flush with heads.
5. Hinge forward left seat forward. Plug B121-1 transmit switch assembly in seat support receptacle.
6. Push-in associated circuit breaker & turn battery switch on. Perform appropriate post-installation function checks. Turn battery switch off.

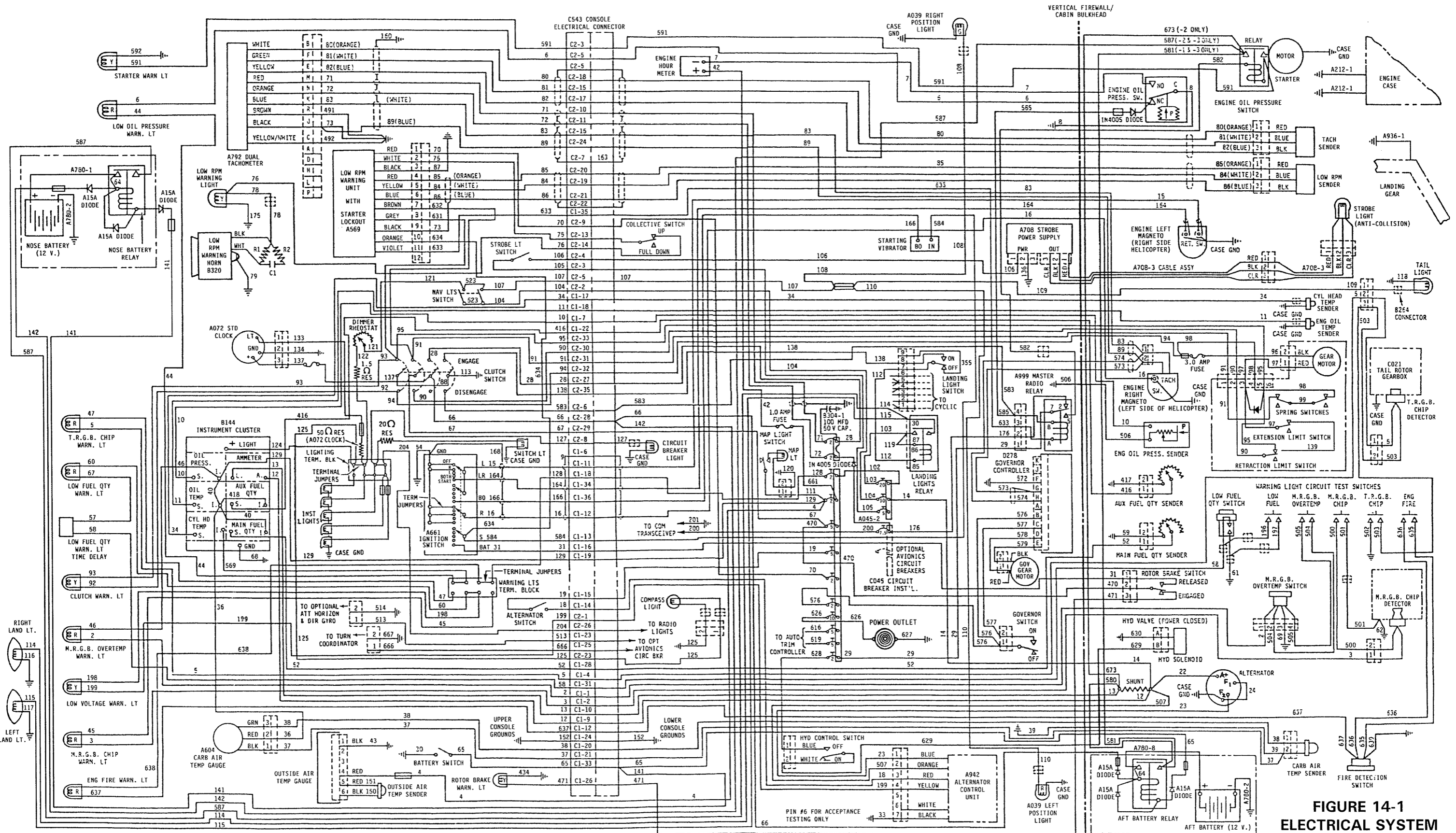
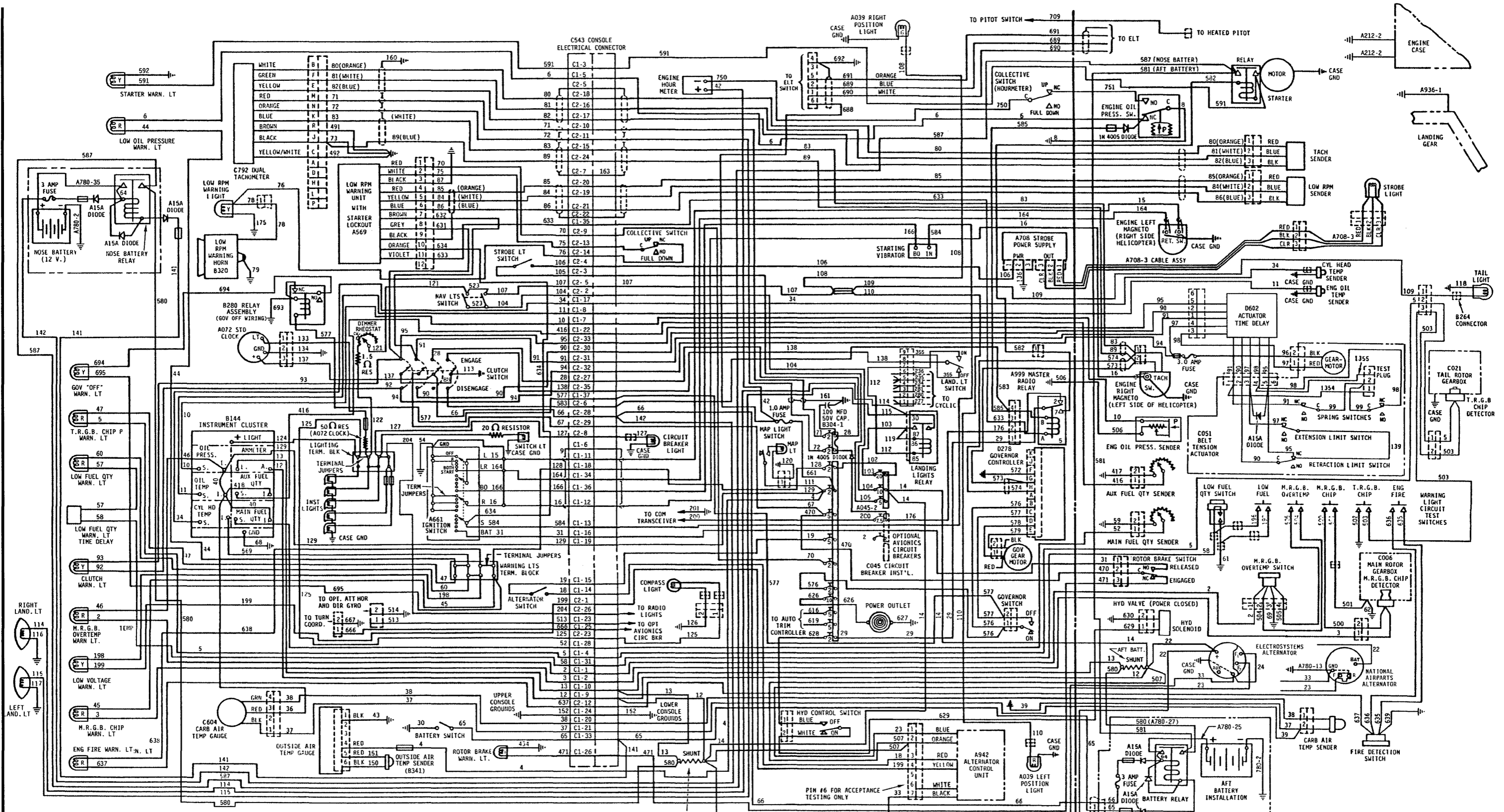
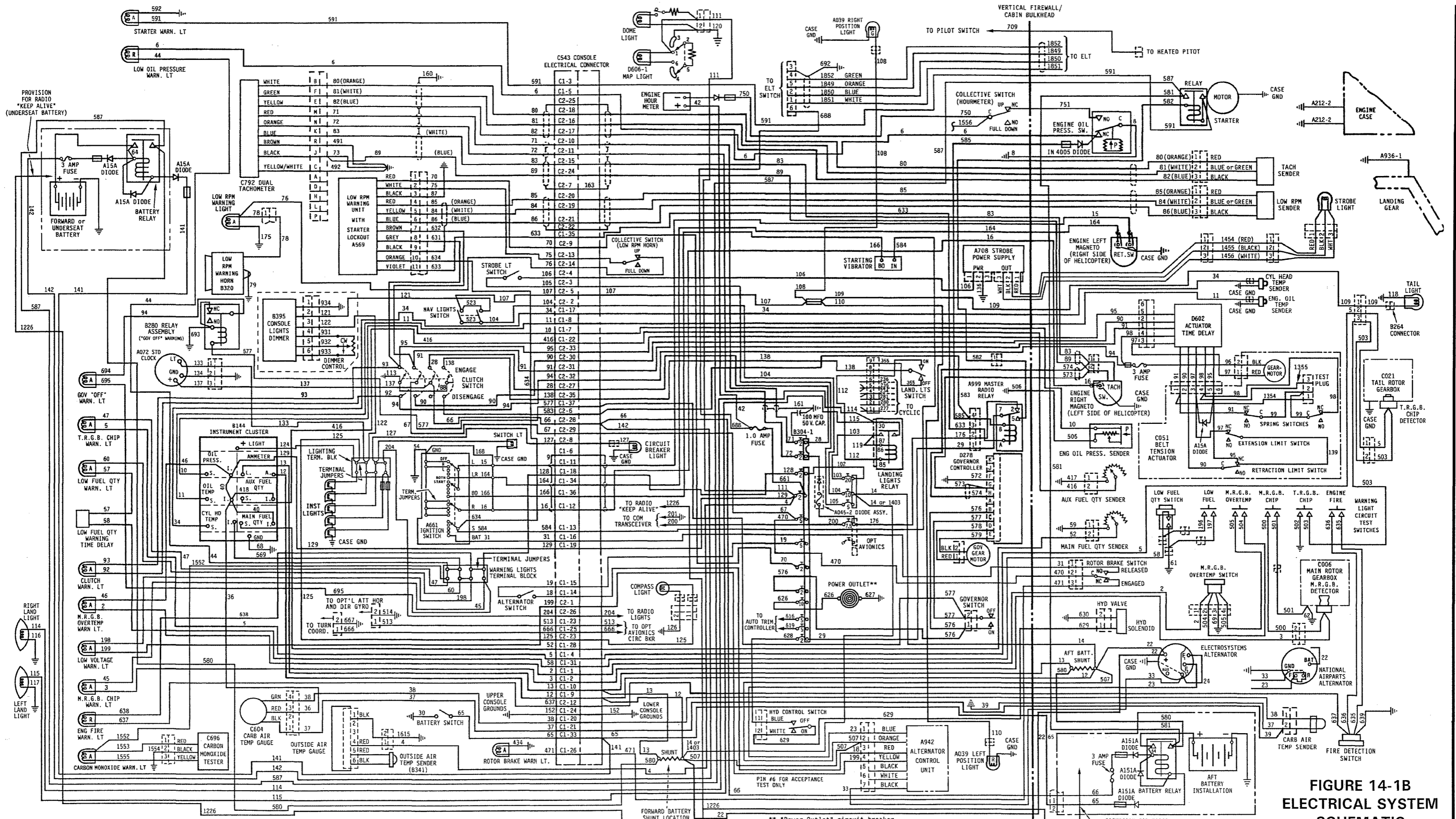

FIGURE 14-1
ELECTRICAL SYSTEM
SCHEMATIC (14-VOLT)



*For 14-volt R44s which have remote ELT switches, clock fuse on firewall, Governor-off warning light, clutch actuator test plug (if equipped), and National Airparts alternator (if equipped).

FIGURE 14-1A
ELECTRICAL SYSTEM
SCHEMATIC 14-VOLT



*For 14-volt R44s with C059 Rev AG and subsequent wire harness, LED map and dome light, and B395 console light dimmer.

** "Power Outlet" circuit breaker is 2 amp (Raven 1) or 10 amp (Raven 1).

FIGURE 14-1B
ELECTRICAL SYSTEM
SCHEMATIC
(14-VOLT)

Intentionally blank

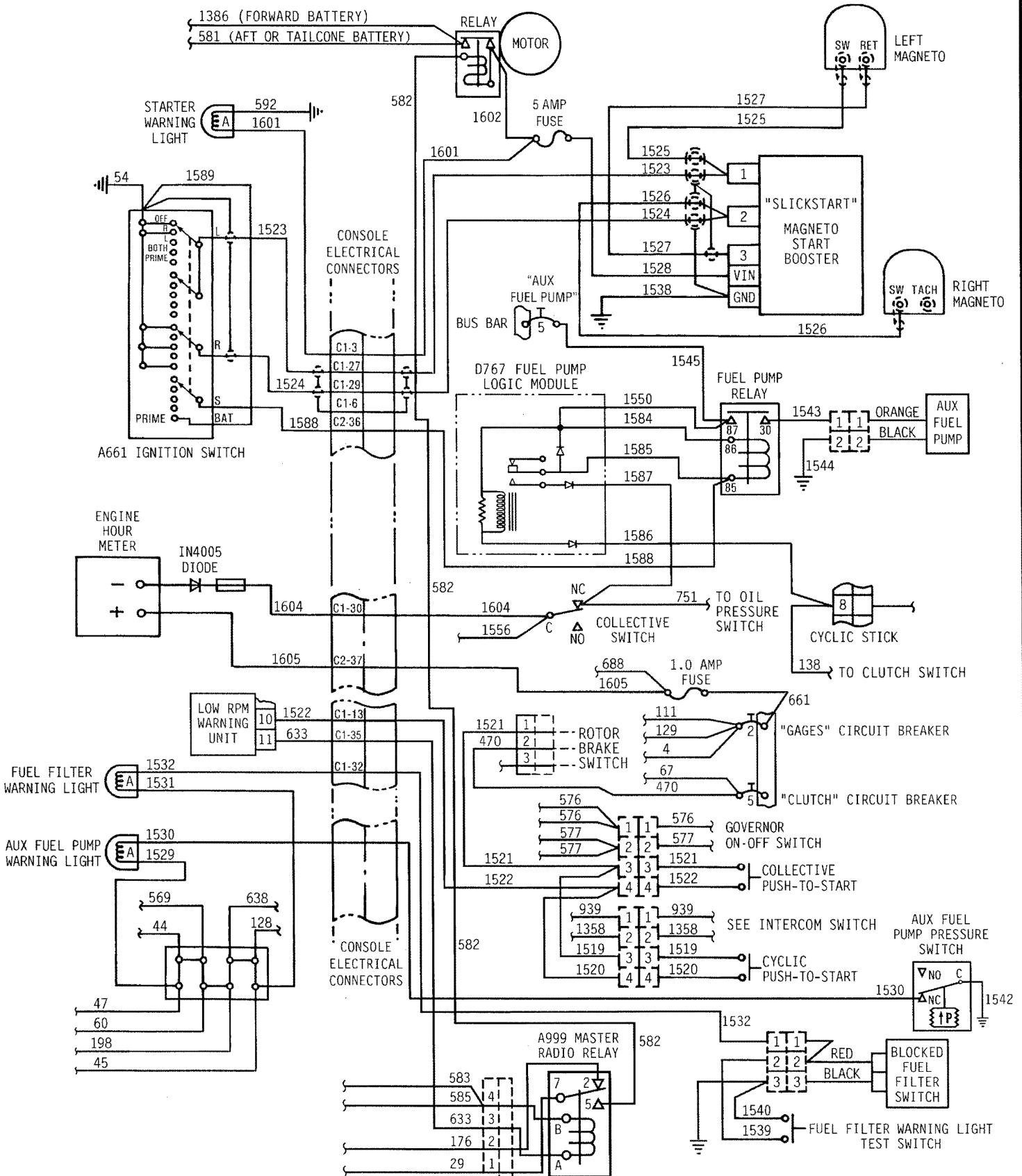

FIGURE 14-1E R44 II (IO-540) STARTING AND FUEL PUMP SCHEMATIC

14.600 ELECTRICAL SYSTEMS SCHEMATICS (Cont'd)

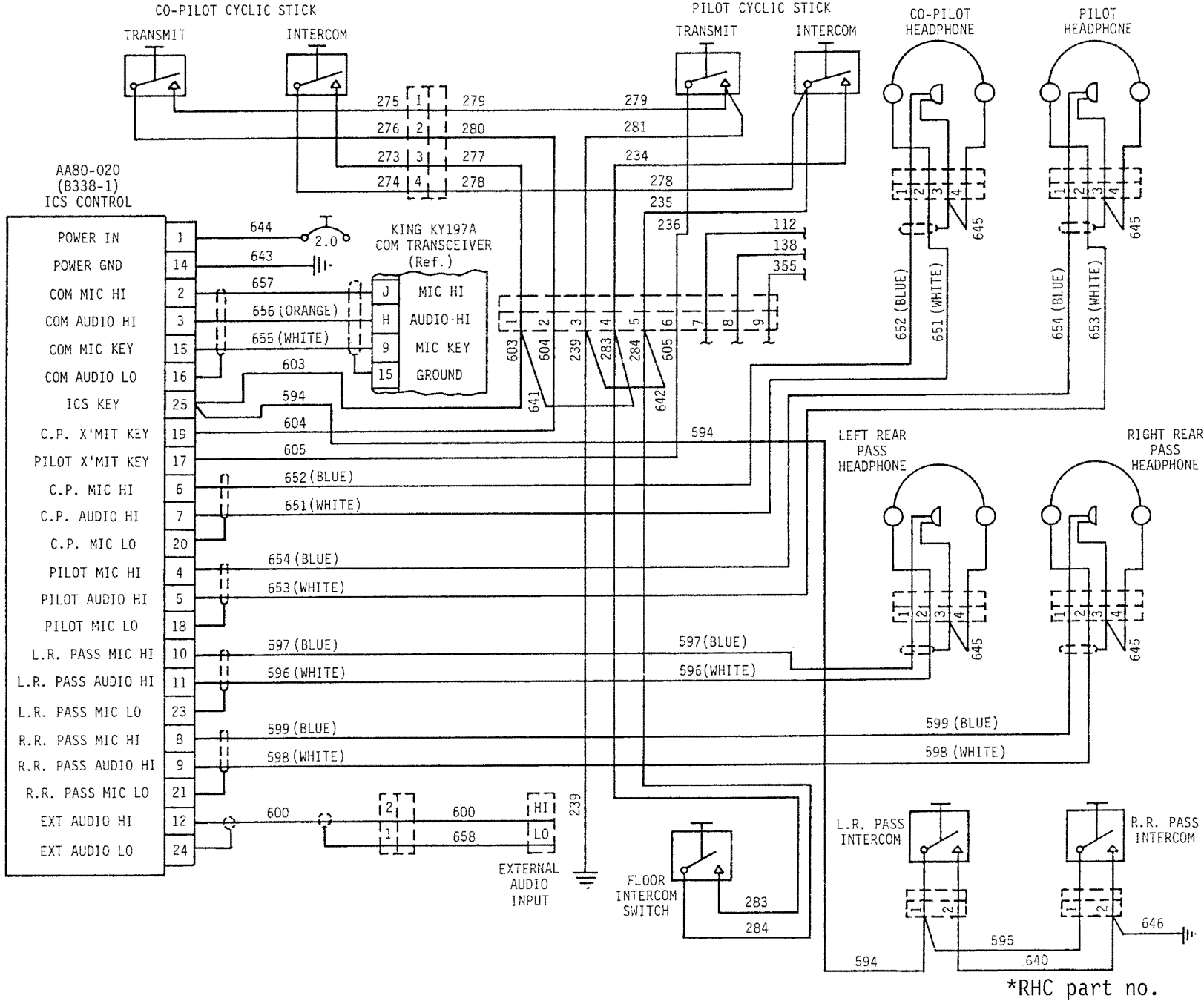
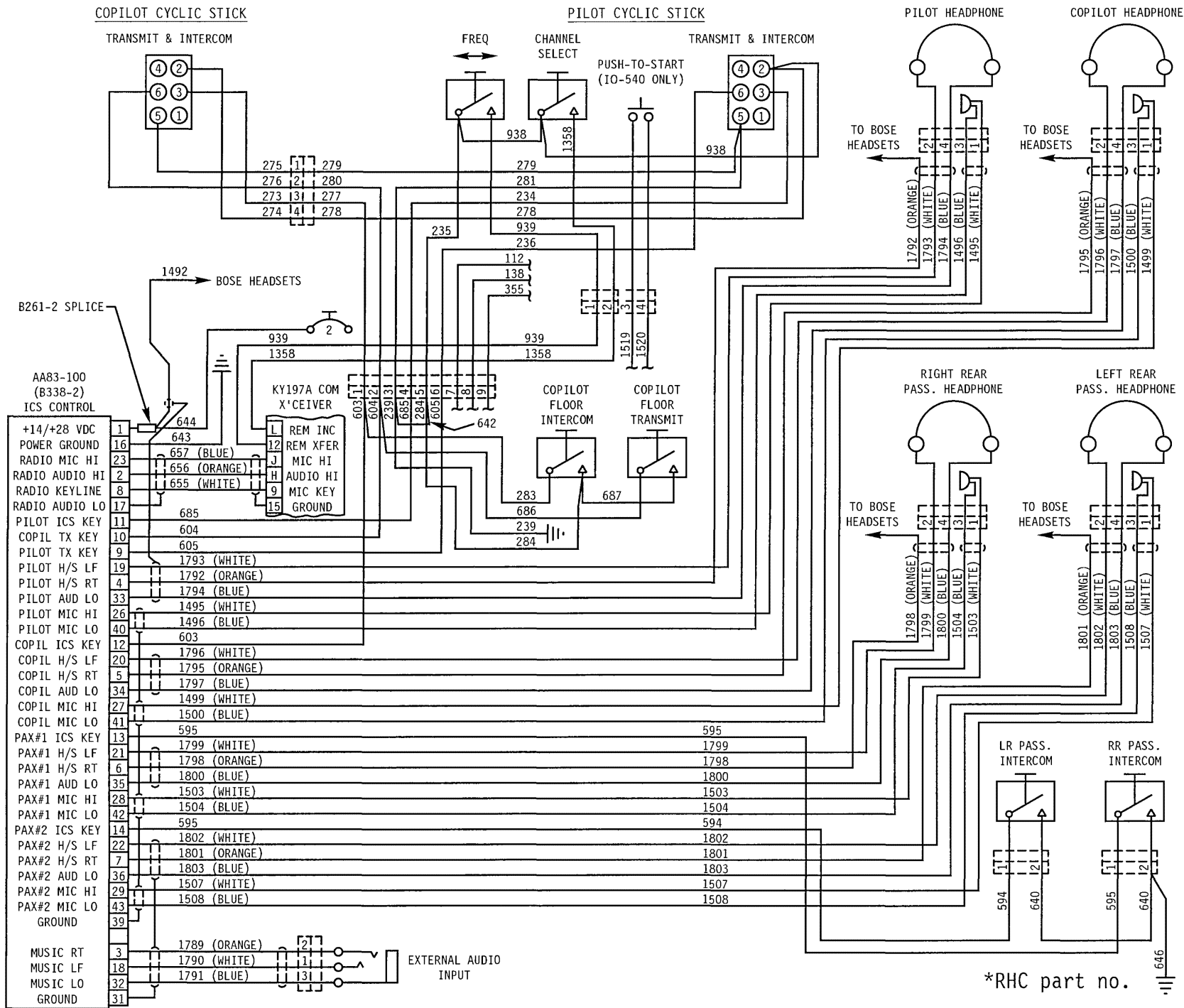

FIGURE 14-2 INTERCOM SCHEMATIC WITH NAT AA80-020 (B338-1*) ICS CONTROL (SHIP S/N 10410 and PRIOR, SHIP S/N 1417 thru PRIOR)

14.600 ELECTRICAL SYSTEMS SCHEMATICS (Cont'd)



*RHC part no.

FIGURE 14-2A INTERCOM SCHEMATIC WITH NAT AA83-100 (B338-2*) ICS CONTROL (SHIP S/N 10410 and SUBSEQUENT, SHIP S/N 1418 thru 9999)

14.600 ELECTRICAL SYSTEMS SCHEMATICS (Cont'd)

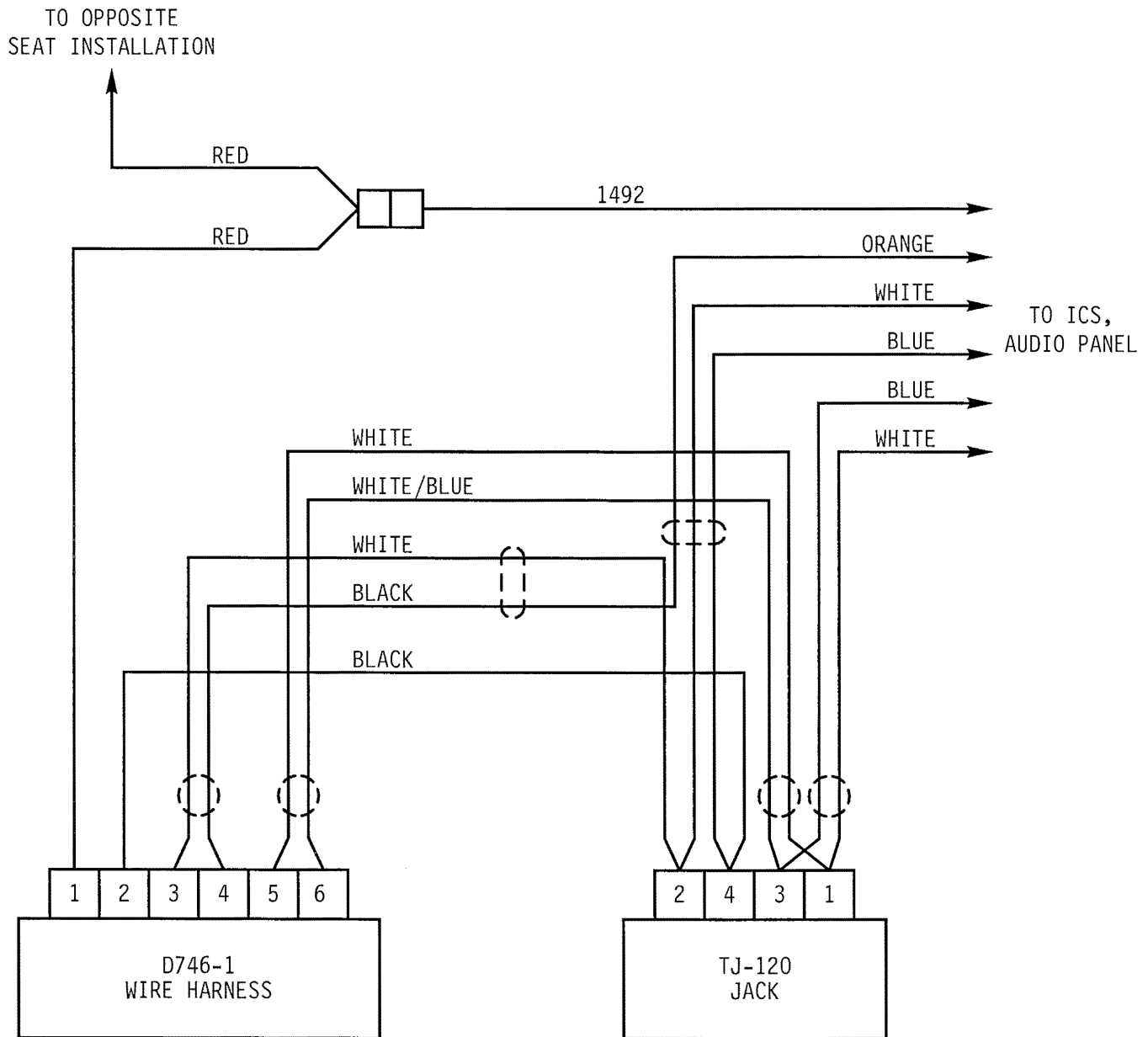

FIGURE 14-2B WIRING SCHEMATIC - BOSE HEADSET

14.600 ELECTRICAL SYSTEM SCHEMATICS (Cont'd)

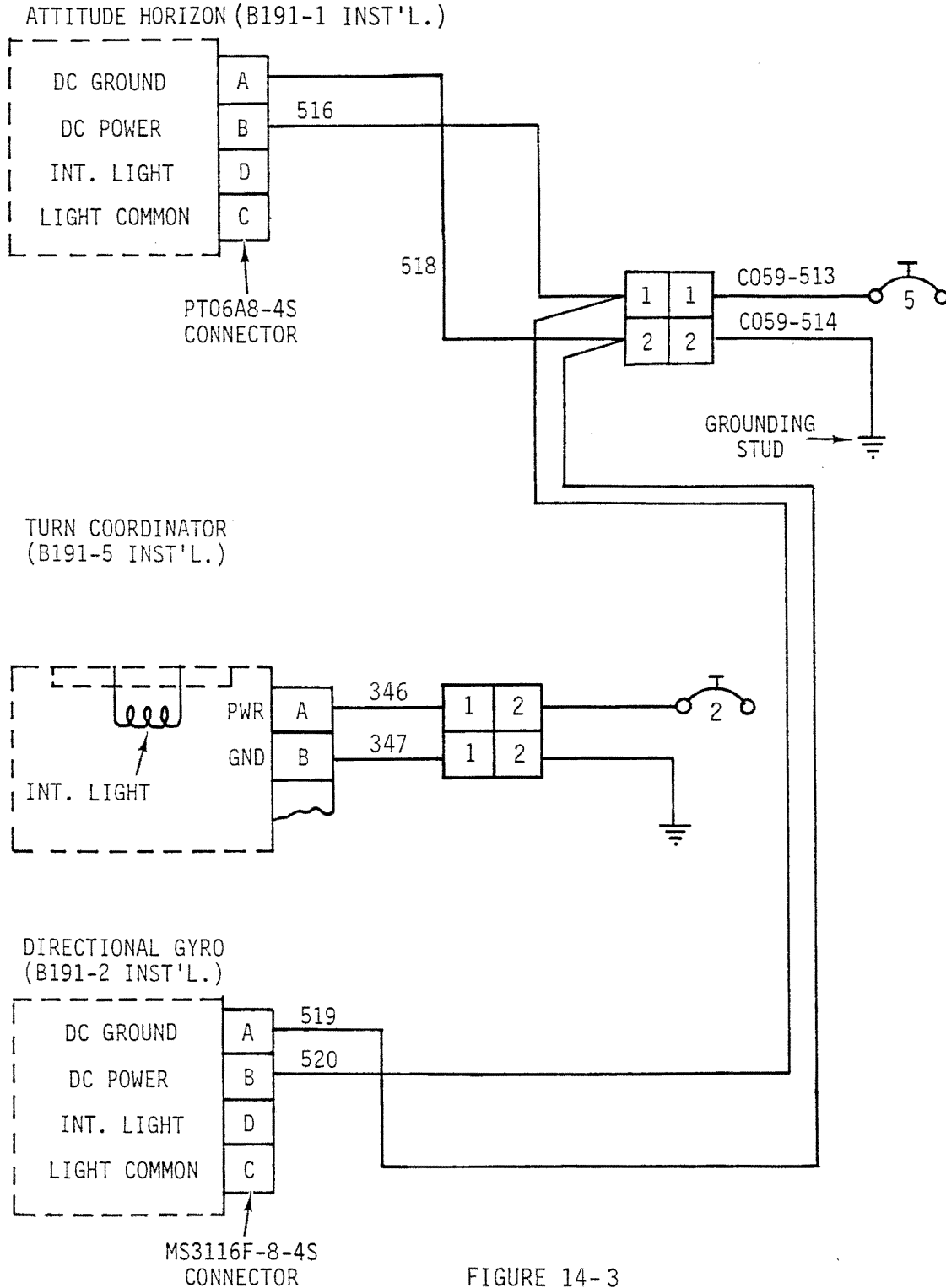
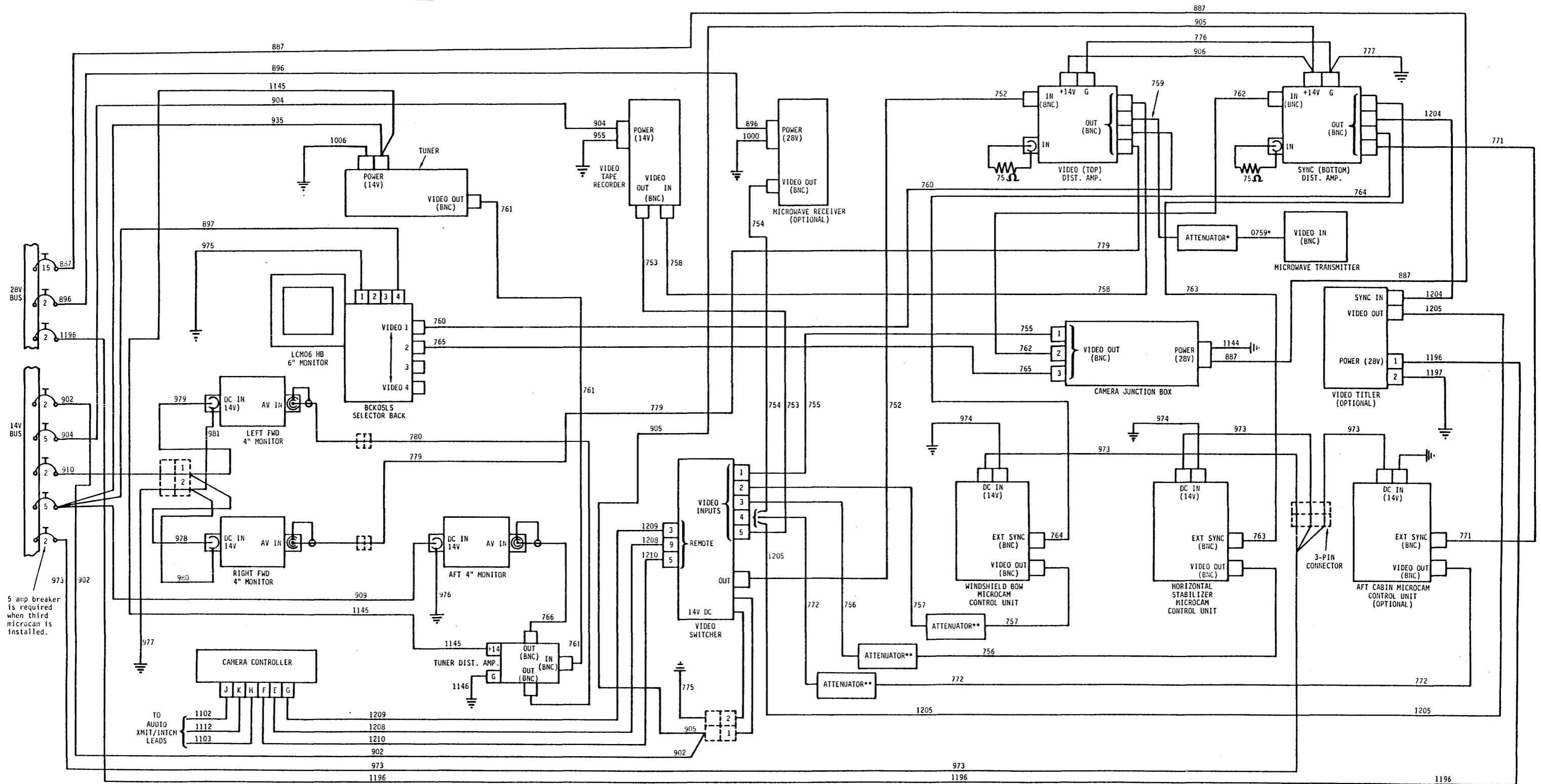

FIGURE 14-3

B191-3 ATTITUDE HORIZON (J.E.T. ELECTRONICS)
 B191-4 DIRECTIONAL GYRO (J.E.T. ELECTRONICS)
 B329-1 TURN COORDINATOR (ELEC. GYRO CORP.)

14.600 ELECTRICAL SYSTEM SCHEMATICS (Cont'd)



5 amp breaker is required when third microcam is installed.

*Installed only if reduced bandwidth is required.
 **31-70019 Coupler may be installed at this location instead.

FIGURE 14-3A
 VIDEO SIGNAL WIRING SCHEMATIC
 (ENG helicopters only)

14.600 ELECTRICAL SYSTEM SCHEMATICS (Cont'd)

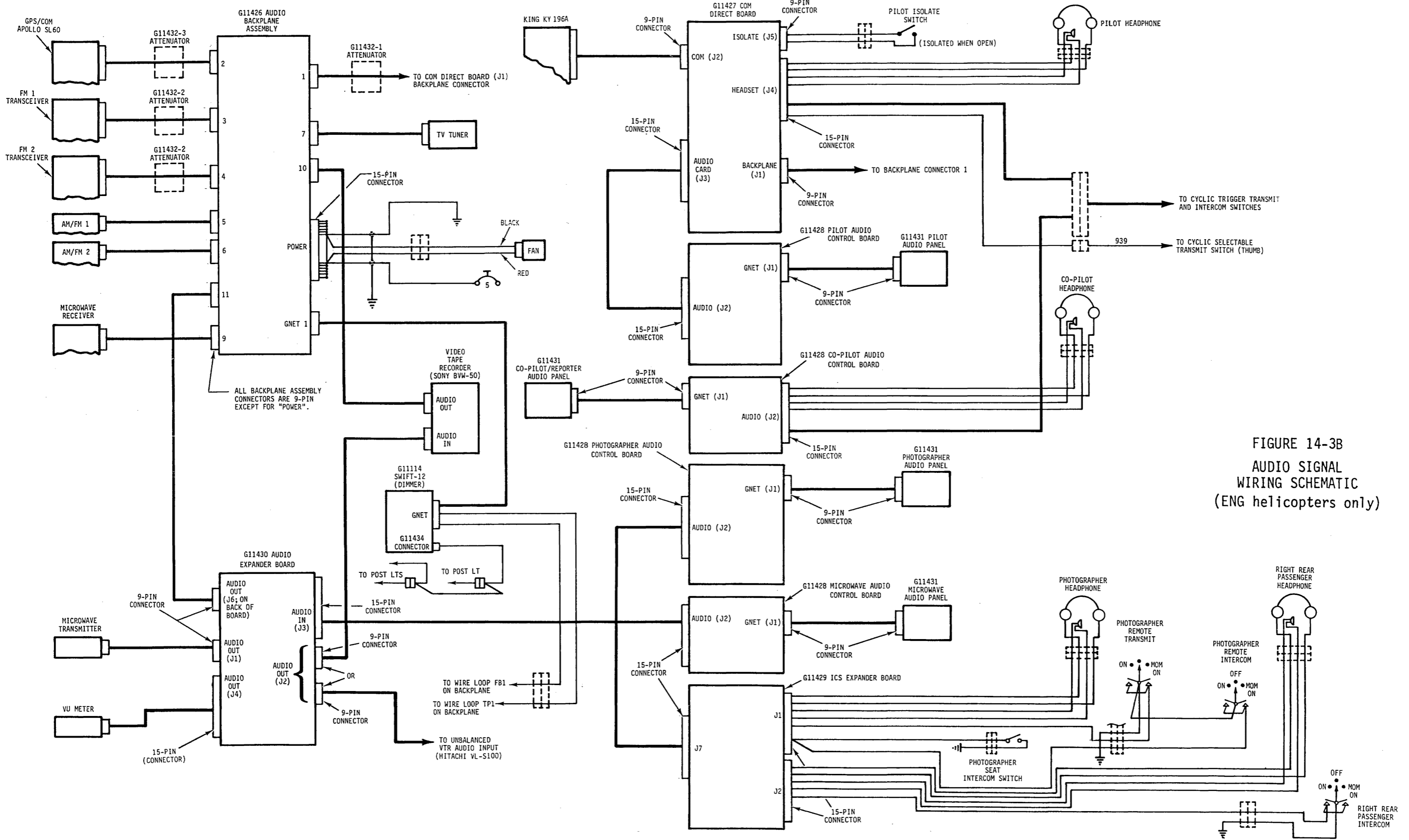

FIGURE 14-3B
AUDIO SIGNAL
WIRING SCHEMATIC
(ENG helicopters only)

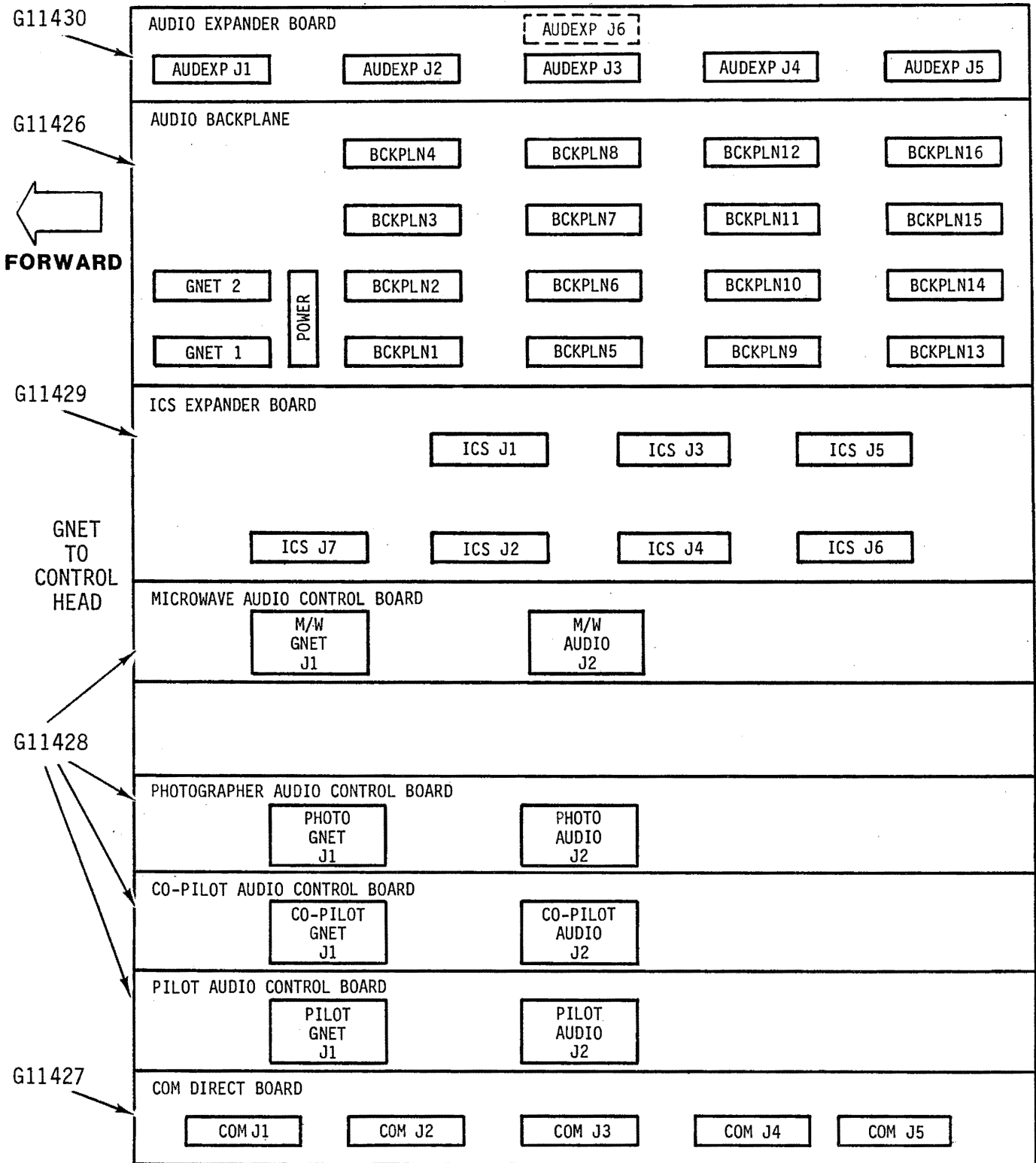
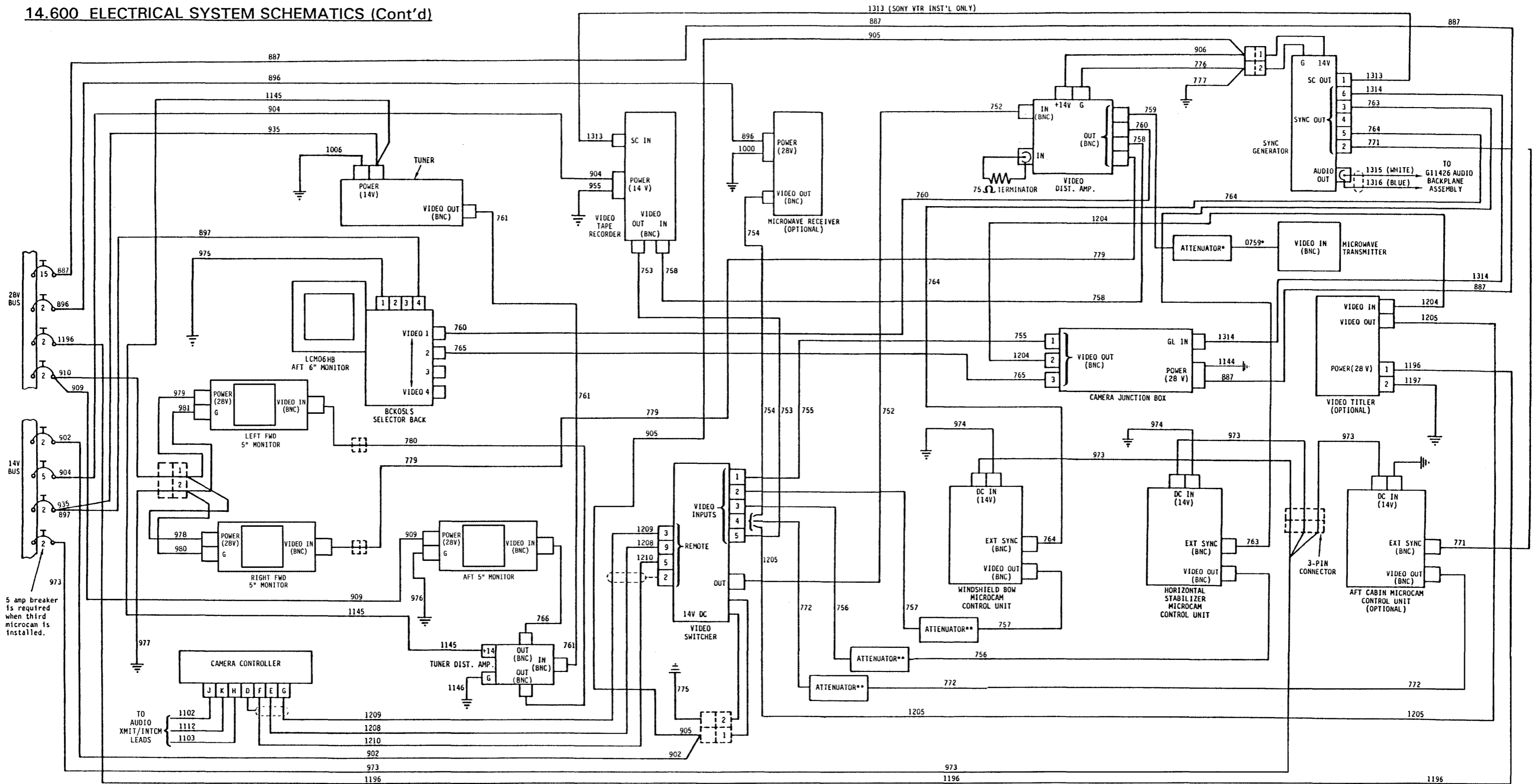

FIGURE 14-3C
 GENEVA BOX AUDIO SIGNAL WIRING
 CONNECTOR DIAGRAM
 (Located beneath forward LH seat, view looking down)

This page intentionally left blank.

14.600 ELECTRICAL SYSTEM SCHEMATICS (Cont'd)



*Installed only if reduced bandwidth is required.

**31-70019 Coupler may be installed at this location instead.

FIGURE 14-3D VIDEO SIGNAL WIRING SCHEMATIC
(ENG helicopters only, ship S/N 469 and on with five-inch monitors. S/N 475 and on have Sync Generator instead of two Video Distribution Amps.)

14.600 ELECTRICAL SYSTEM SCHEMATICS (Cont'd)

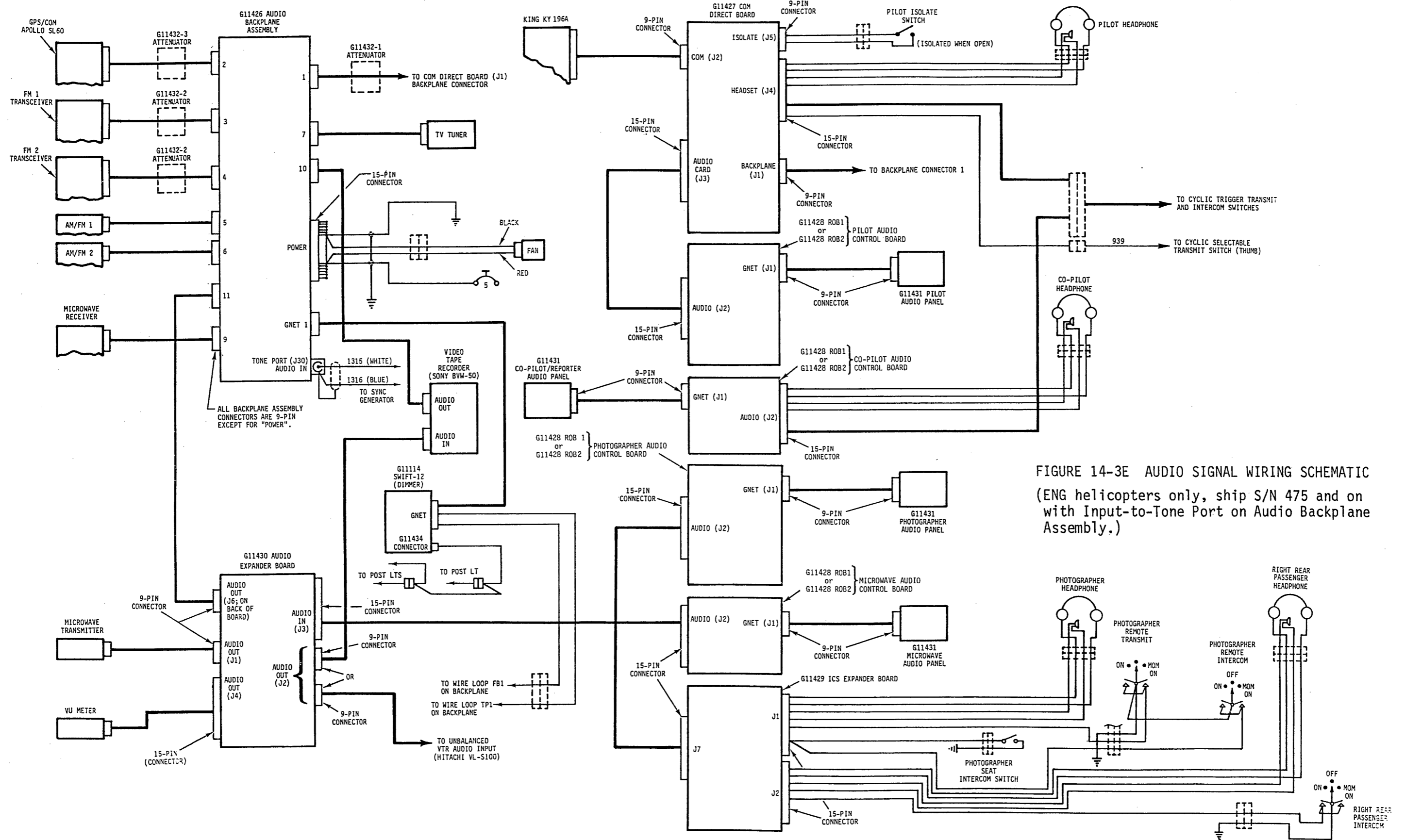
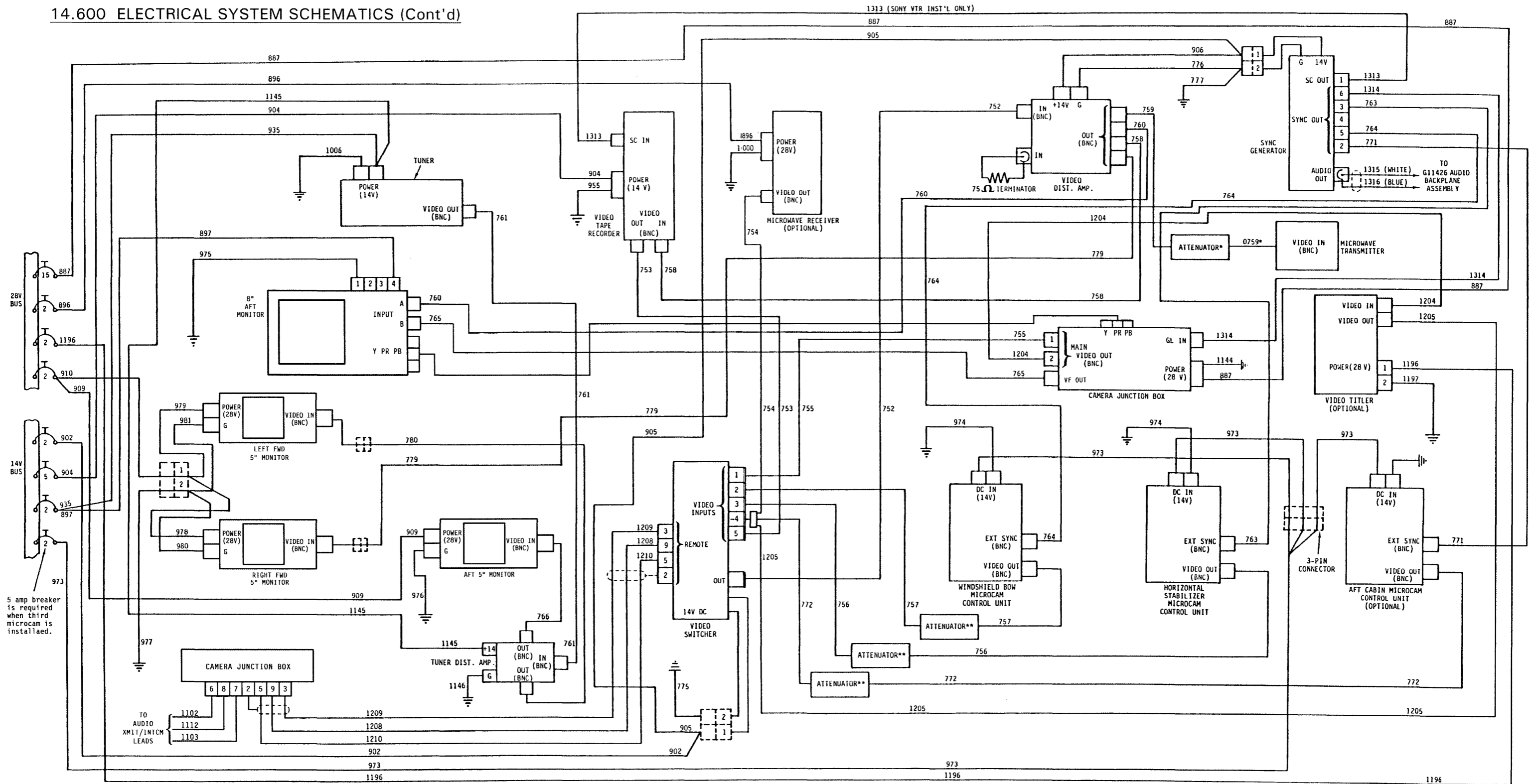

FIGURE 14-3E AUDIO SIGNAL WIRING SCHEMATIC
(ENG helicopters only, ship S/N 475 and on
with Input-to-Tone Port on Audio Backplane
Assembly.)

14.600 ELECTRICAL SYSTEM SCHEMATICS (Cont'd)



5 amp breaker is required when third microcam is installed.

*Installed only if reduced bandwidth is required.

**31-70019 Coupler may be installed at this location instead.

FIGURE 14-3D VIDEO SIGNAL WIRING SCHEMATIC (ENG helicopters only, ship S/N 10016 and on)

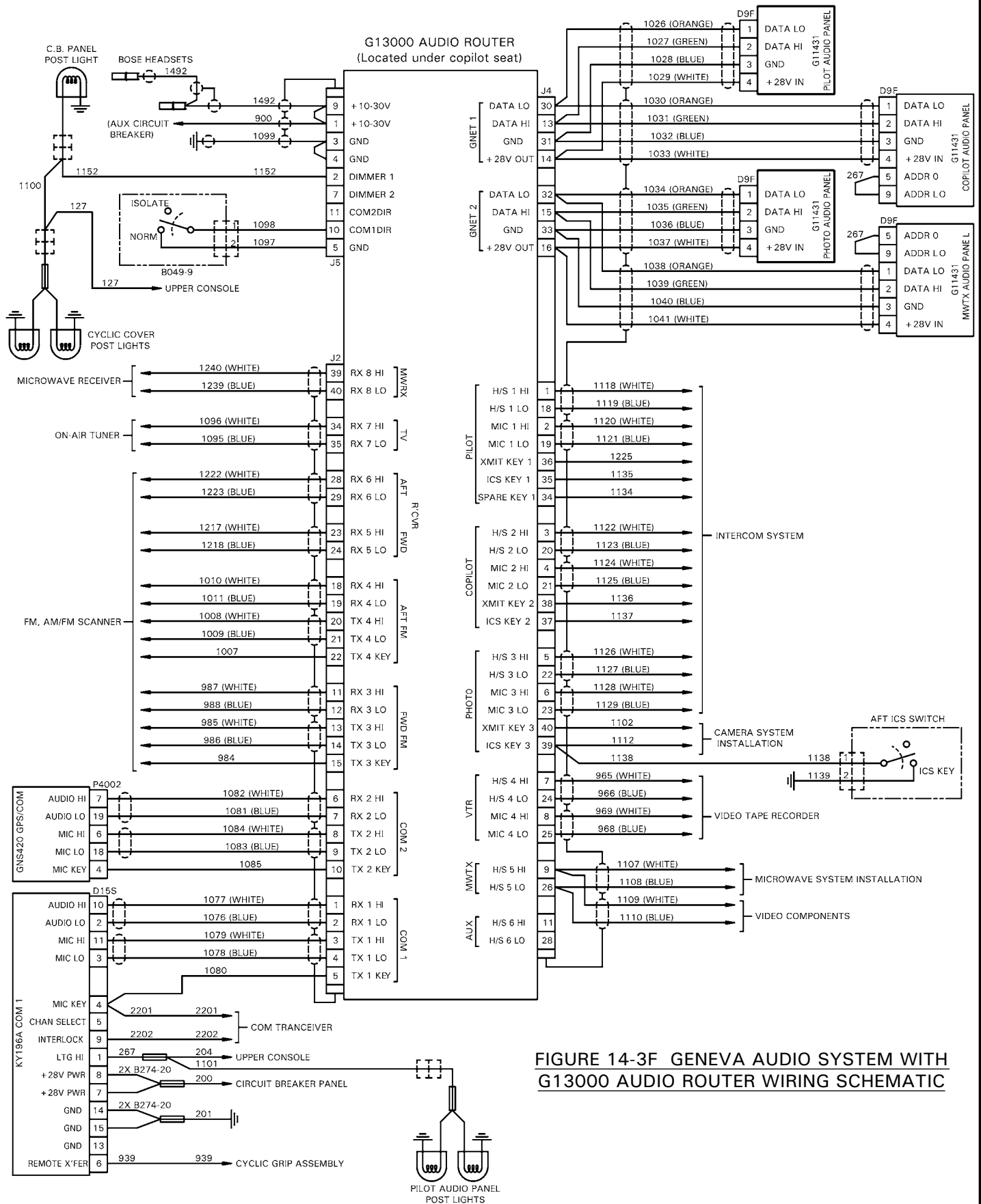

FIGURE 14-3F GENEVA AUDIO SYSTEM WITH G13000 AUDIO ROUTER WIRING SCHEMATIC

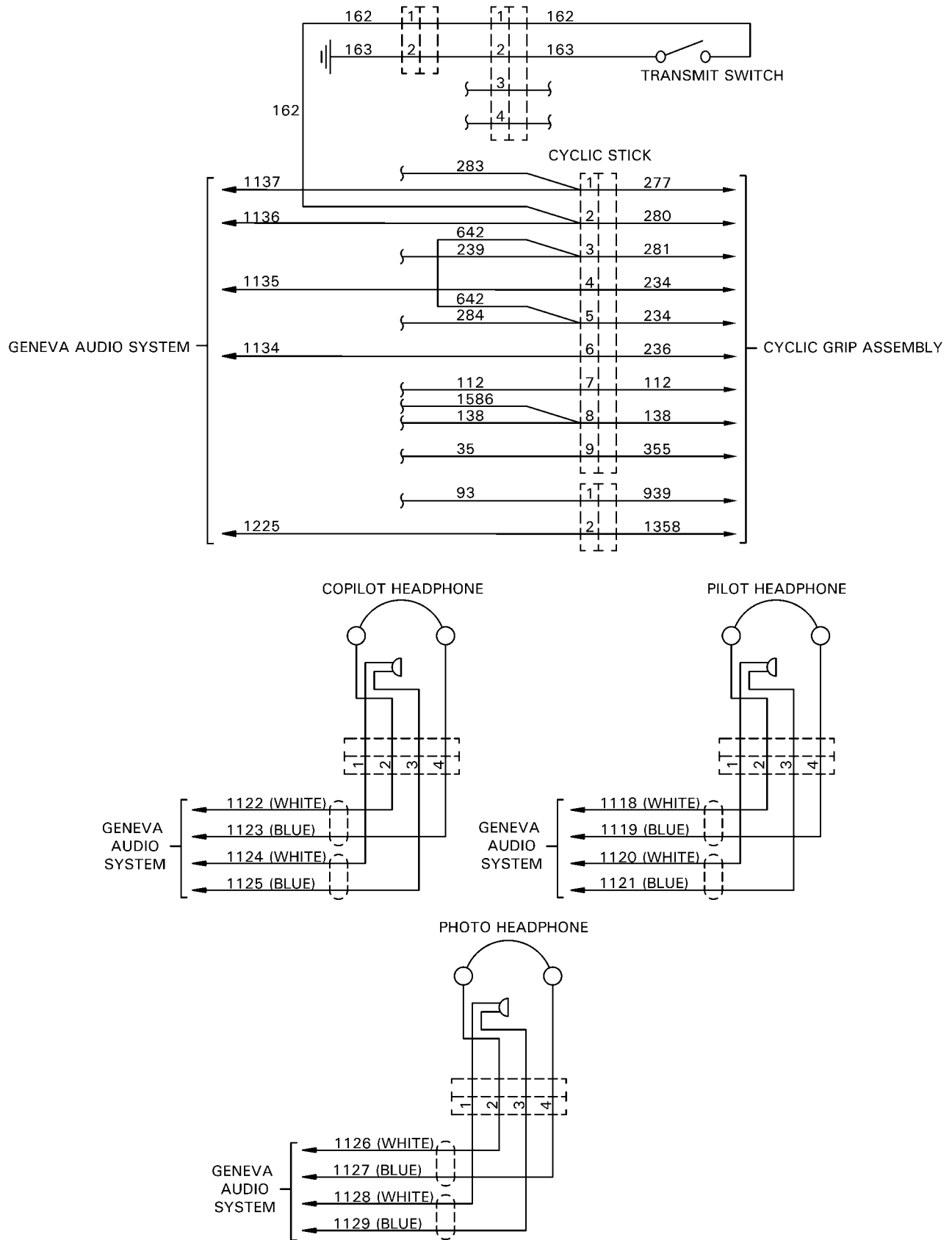

FIGURE 14-3G INTERCOM SYSTEM WIRING SCHEMATIC FOR E.N.G. HELICOPTERS WITH G13000 AUDIO ROUTER GENEVA AUDIO SYSTEM

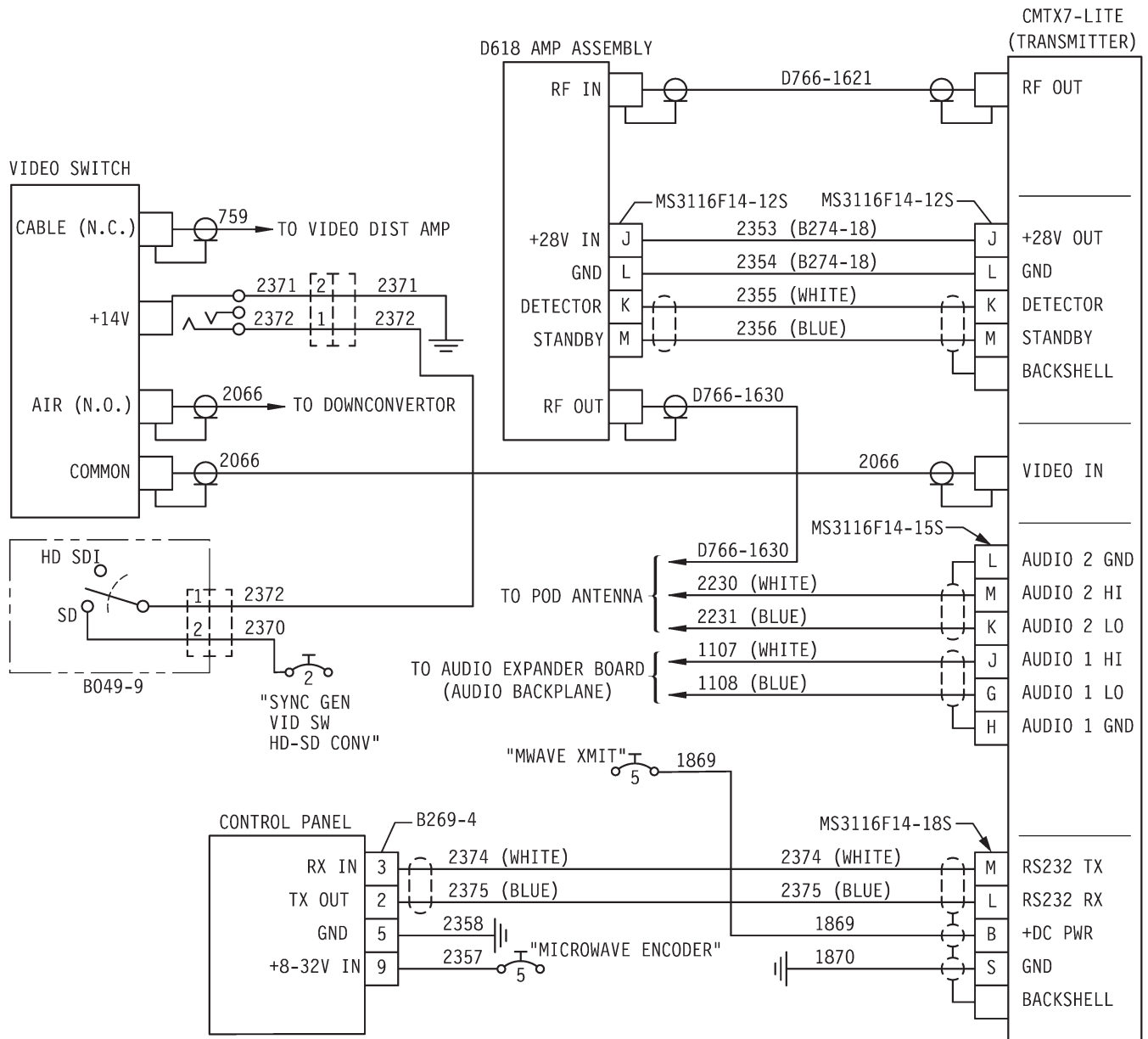

FIGURE 14-3H D056-1 MICROWAVE SYSTEM INSTALLATION

Intentionally Blank

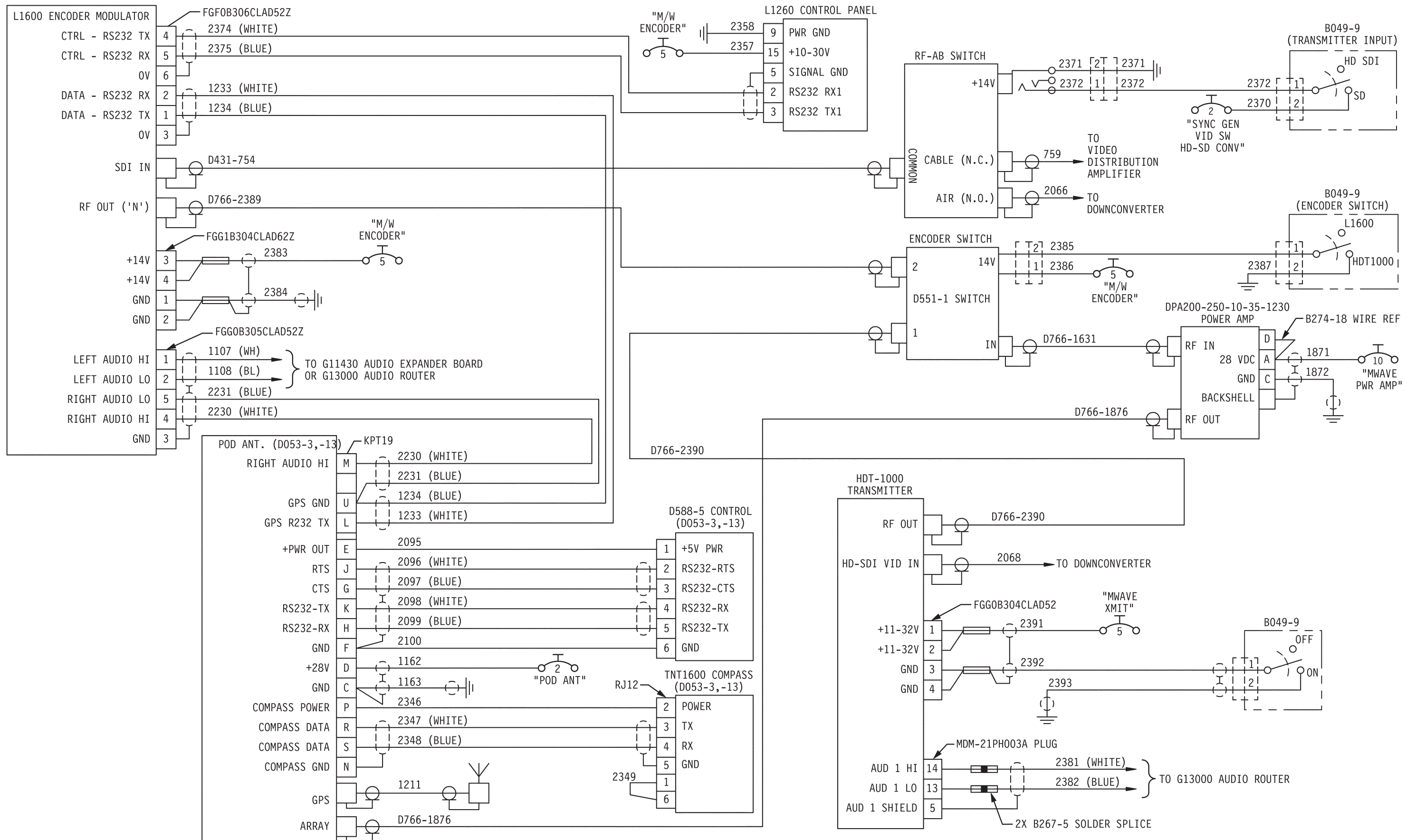

FIGURE 14-31 D056-2 MICROWAVE SYSTEM INSTALLATION

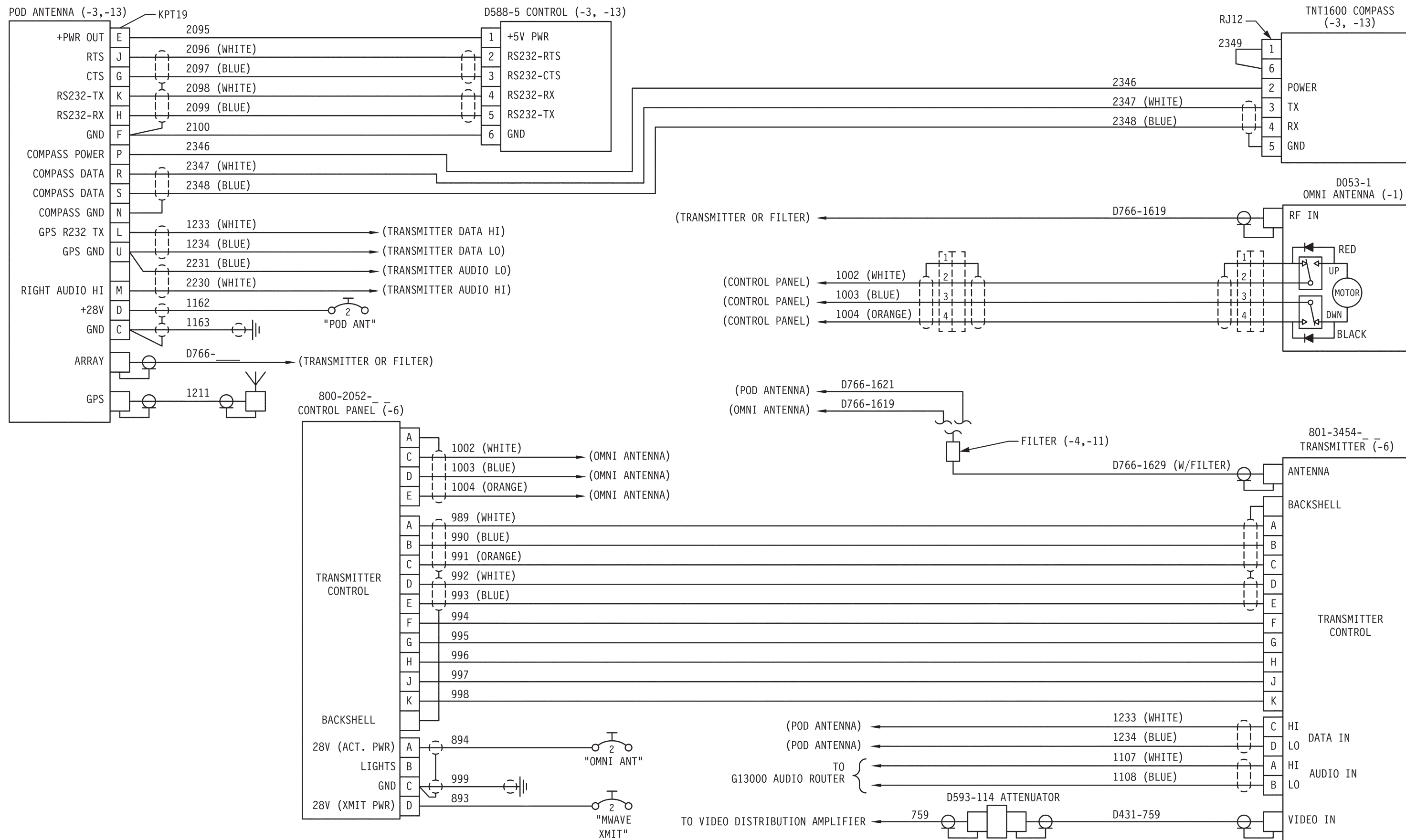

FIGURE 14-3J D053-1, -3, -4, -5, -6, & -11 MICROWAVE SYSTEM INSTALLATION

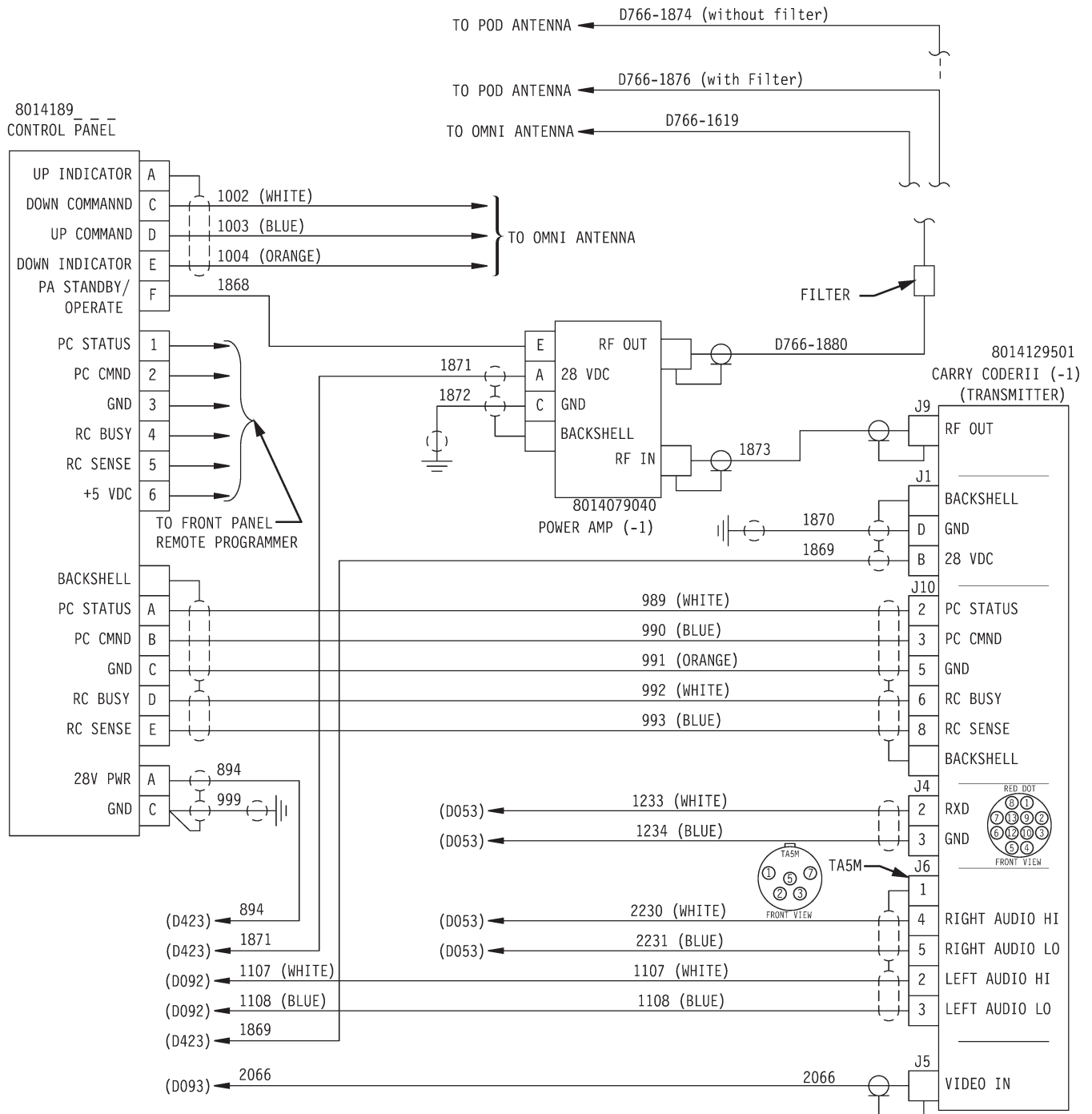

FIGURE 14-3K D055 DIGITAL MICROWAVE SYSTEM INSTALLATION

Intentionally Blank

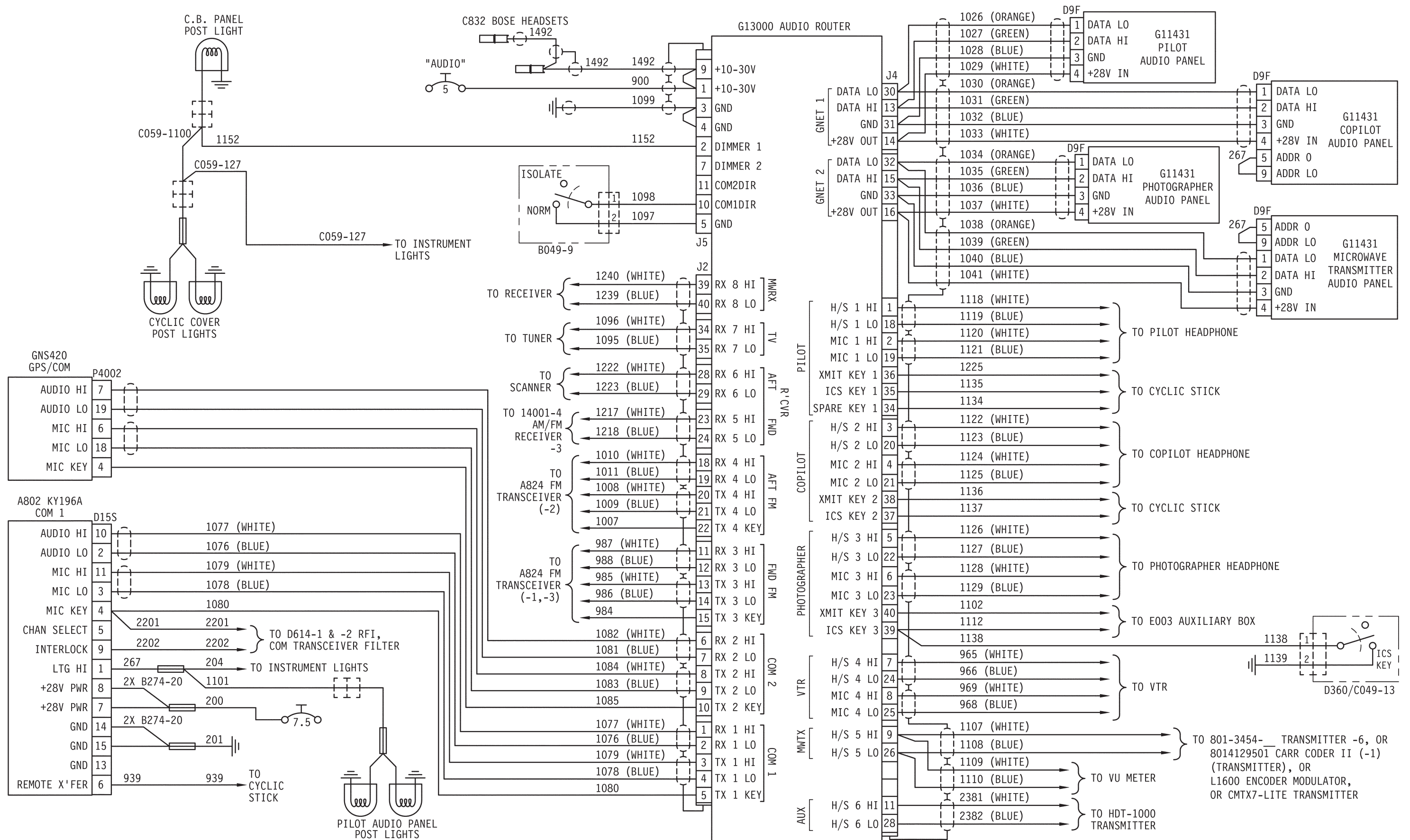

FIGURE 14-3L D092-6 GENEVA AUDIO SYSTEM INSTALLATION

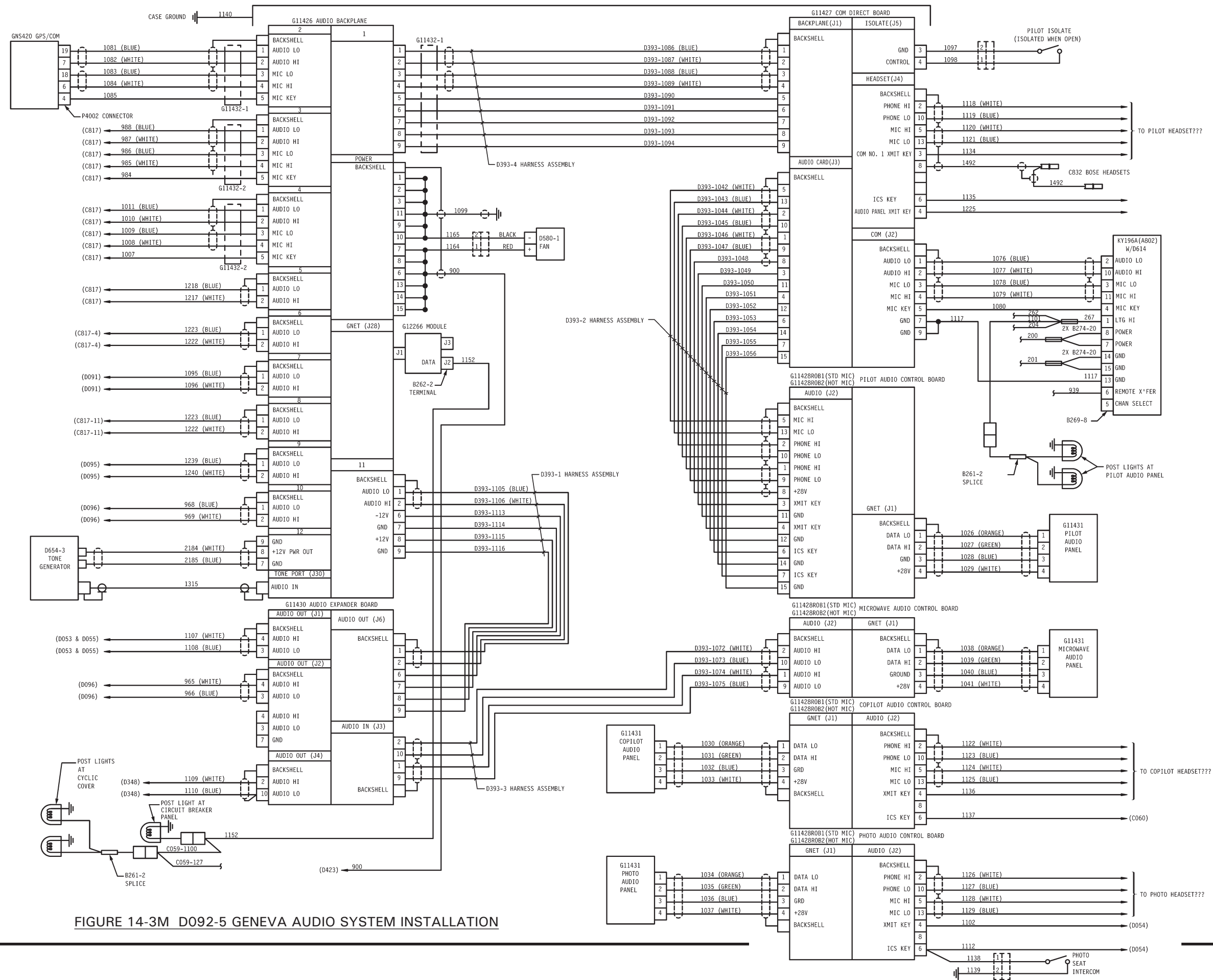

FIGURE 14-3M D092-5 GENEVA AUDIO SYSTEM INSTALLATION

14.700 [Reserved.]

|

Intentionally Blank

Intentionally Blank

Intentionally Blank

14.800 Antenna Locations

Antenna Locations information has been moved to § 16-70.

Intentionally Blank

14.900 AVIONICS SCHEMATICS

The basic communications wiring common to all the Com. radio configurations include a N.A.T. Intercom System that provides a voice-activated intercom and Pilot and Co-Pilot cyclic stick switches. In addition, an intercom switch at each of the 2 rear seats can also activate the intercom.

The pilot's and co-pilots individual headphone jacks are mounted to the ceiling and a little behind their respective heads. The rear passenger headphone jacks are contained in a com box centered at the rear most portion of the cabin ceiling. The pilot can use the Pilot "Isolate" switch which will remove him from the Intercom bus; he can then communicate over the com radio without disturbances.

14.900 AVIONICS SCHEMATICS (Cont'd)

This page intentionally left blank.

14.900 AVIONICS SCHEMATICS (Cont'd)

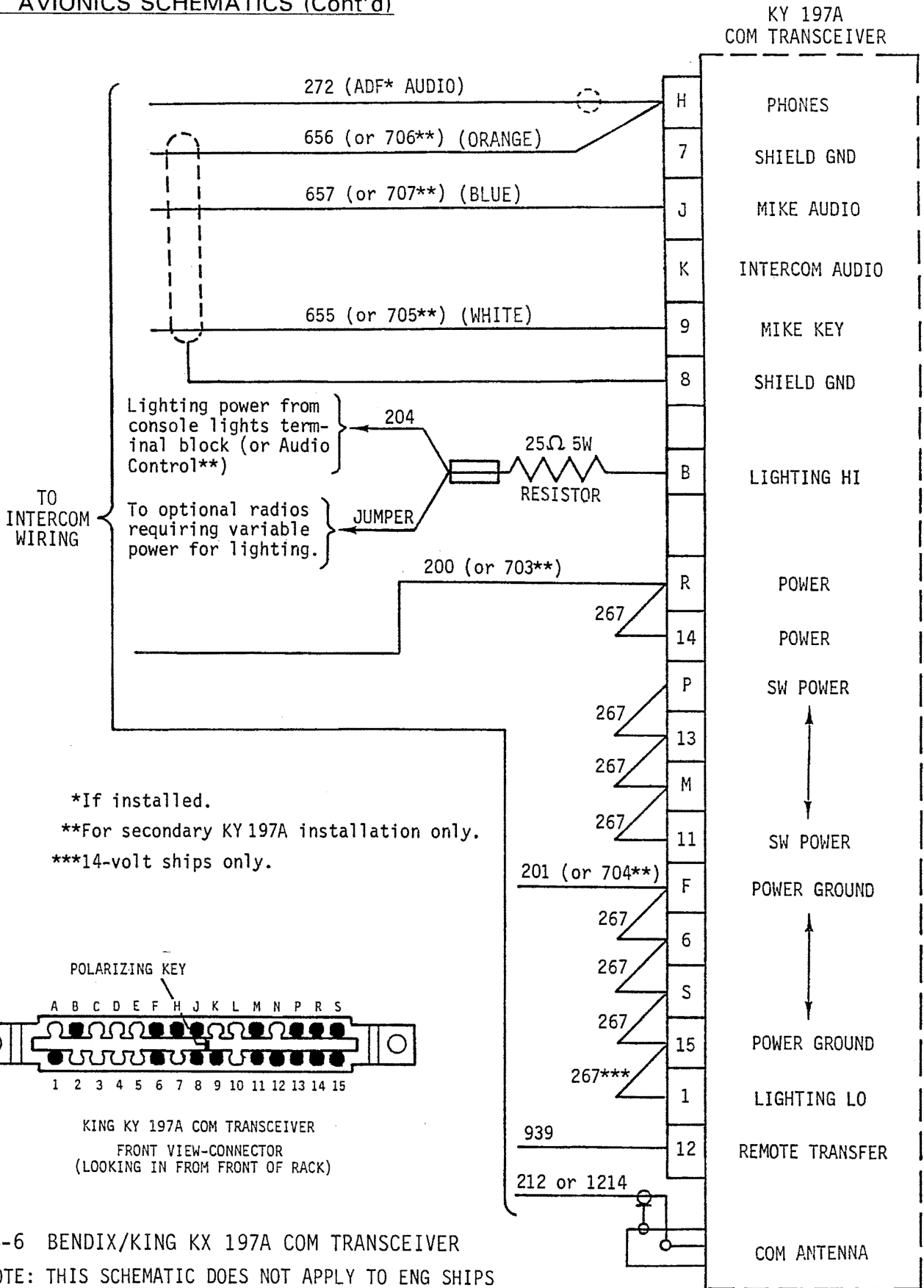

FIGURE 14-6 BENDIX/KING KX 197A COM TRANSCEIVER

NOTE: THIS SCHEMATIC DOES NOT APPLY TO ENG SHIPS WITH GENEVA AUDIO SYSTEM.

14.900 AVIONICS SCHEMATICS (Cont'd)

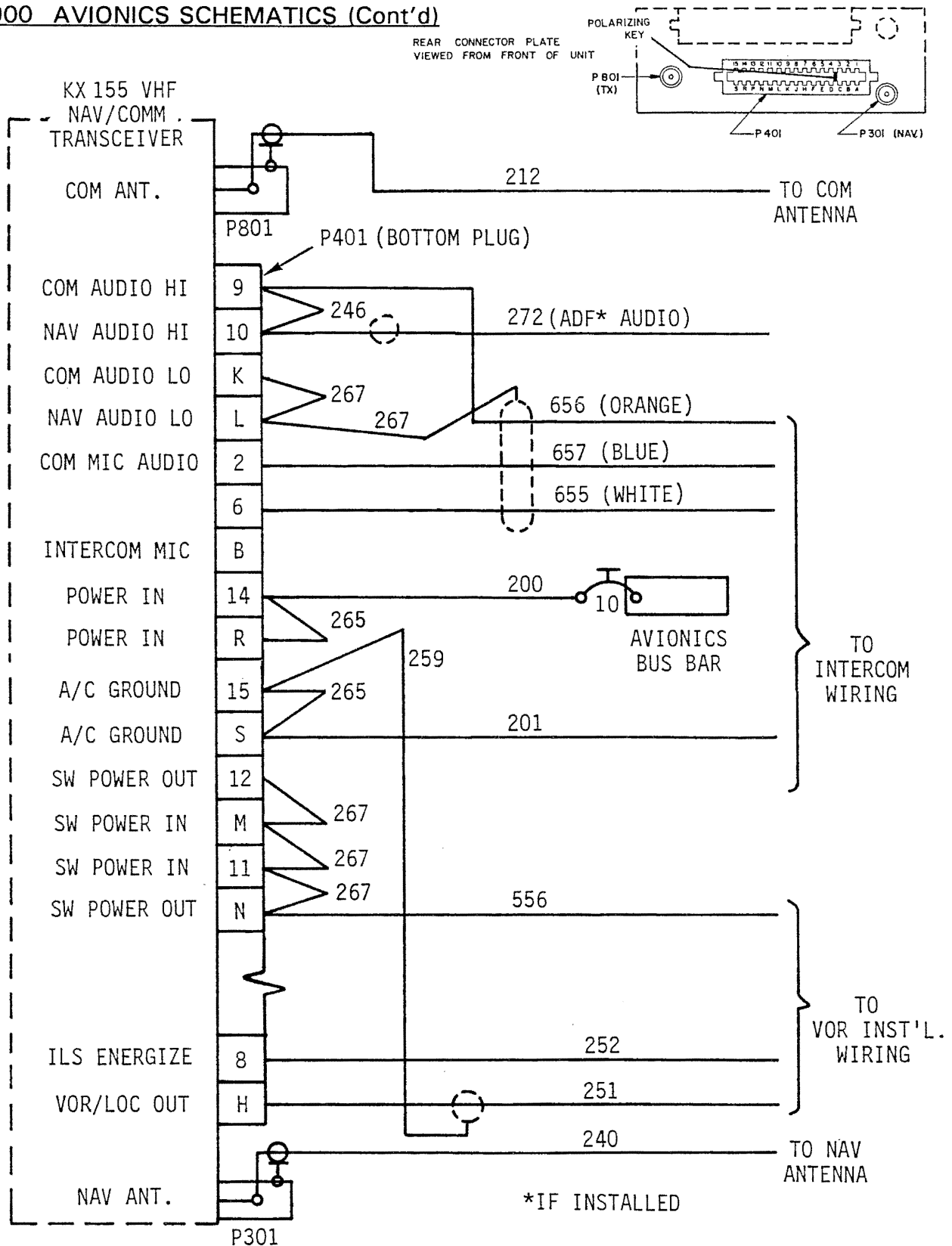

FIGURE 14-7 BENDIX/KING KX 155 VHF NAV/COMM TRANSCEIVER

14.900 AVIONICS SCHEMATICS (Cont'd)

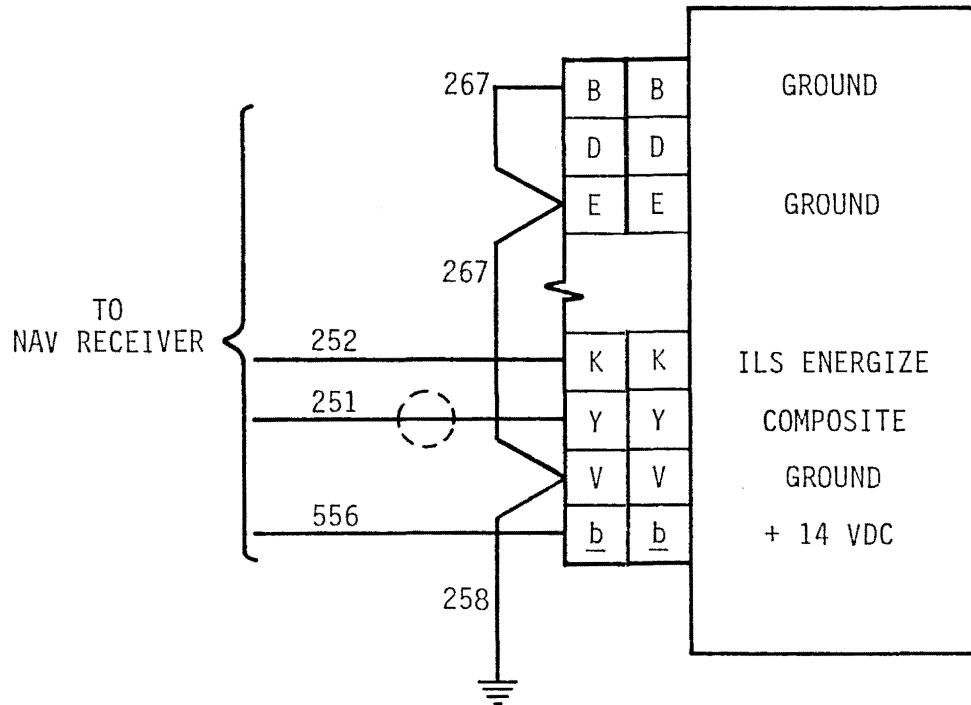

FIGURE 14-8 BENDIX/KING KI 203 VOR INDICATOR

14.900 AVIONICS SCHEMATICS (Cont'd)

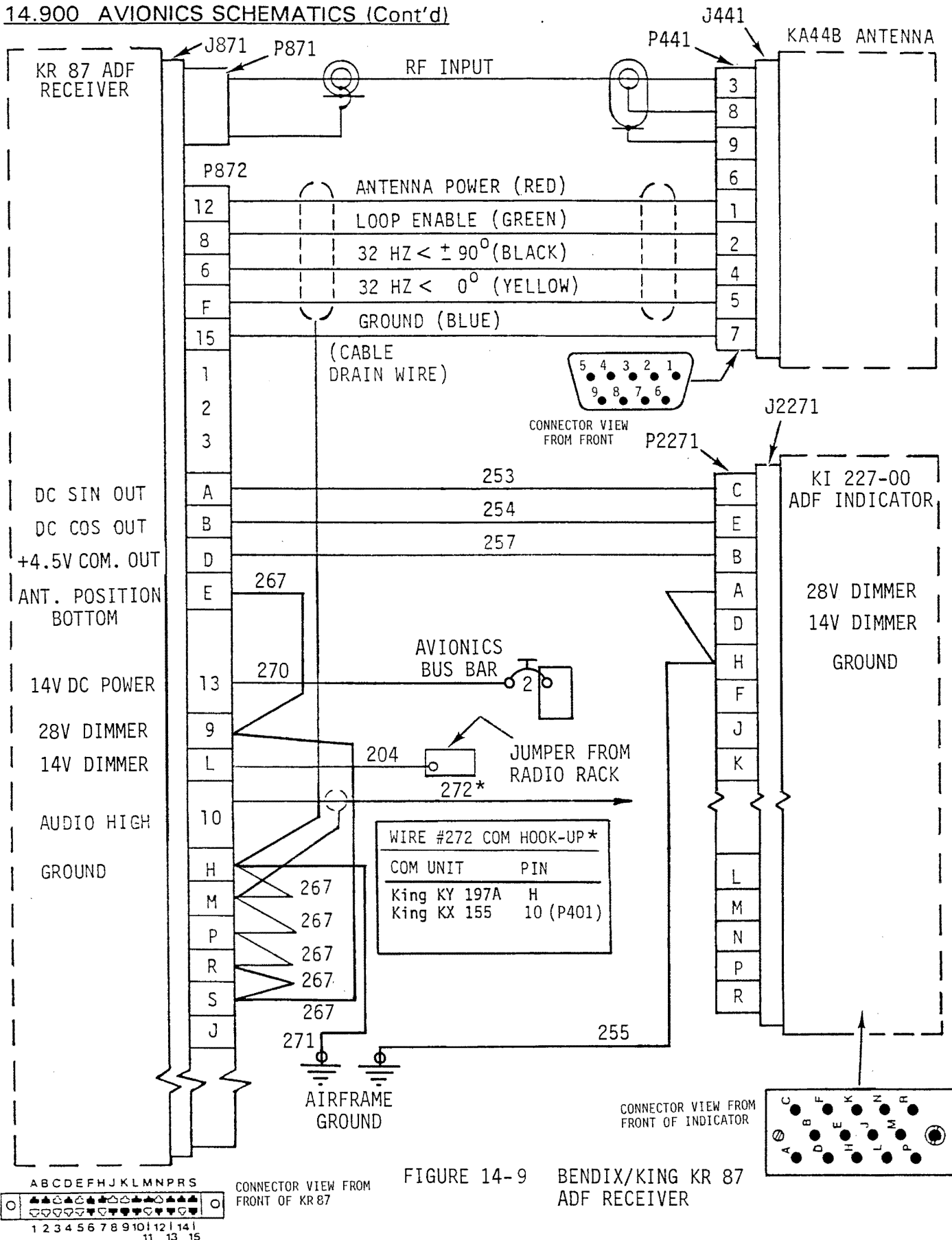

FIGURE 14-9 BENDIX/KING KR 87 ADF RECEIVER

14.900 AVIONICS SCHEMATICS (Cont'd)

KT 76A TRANSPONDER

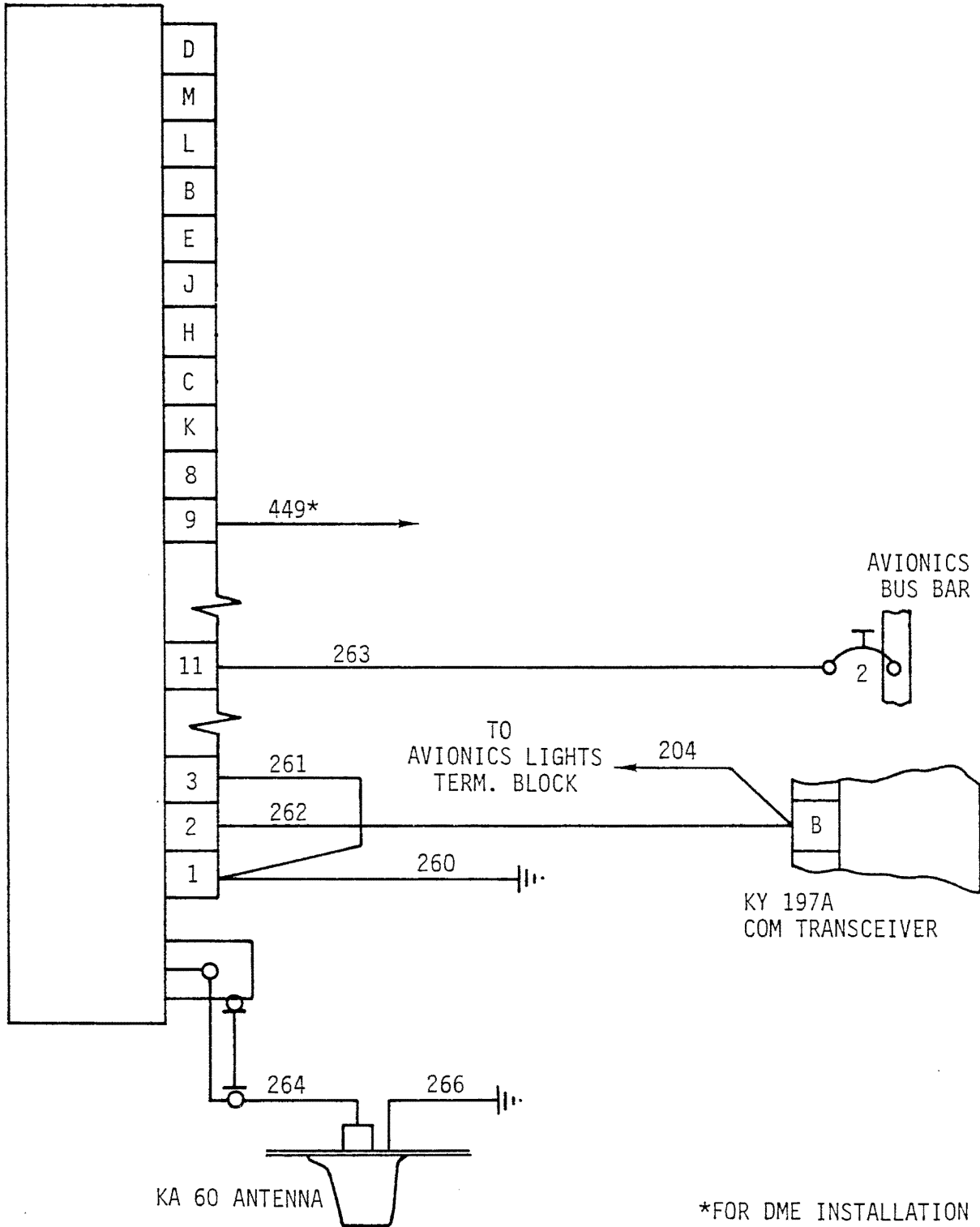
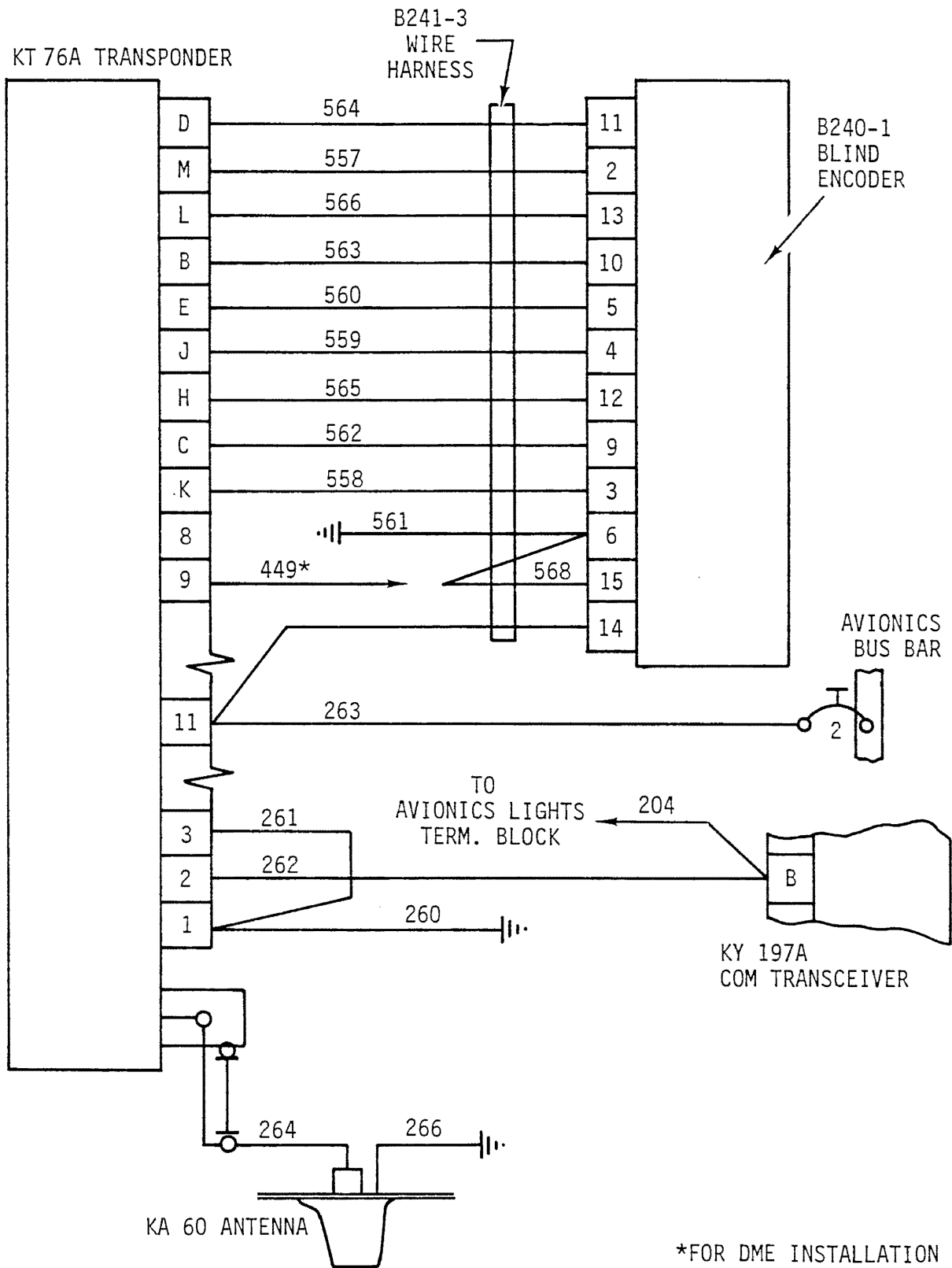

FIGURE 14-10 BENDIX/KING KT 76A TRANSPONDER

14.900 AVIONICS SCHEMATICS (Cont'd)



*FOR DME INSTALLATION ONLY. CONNECT TO PIN "K" OF KN 63 DME.

FIGURE 14-11 BENDIX/KING KT 76A TRANSPONDER WITH BLIND ENCODER

14.900 AVIONICS SCHEMATICS (Cont'd)

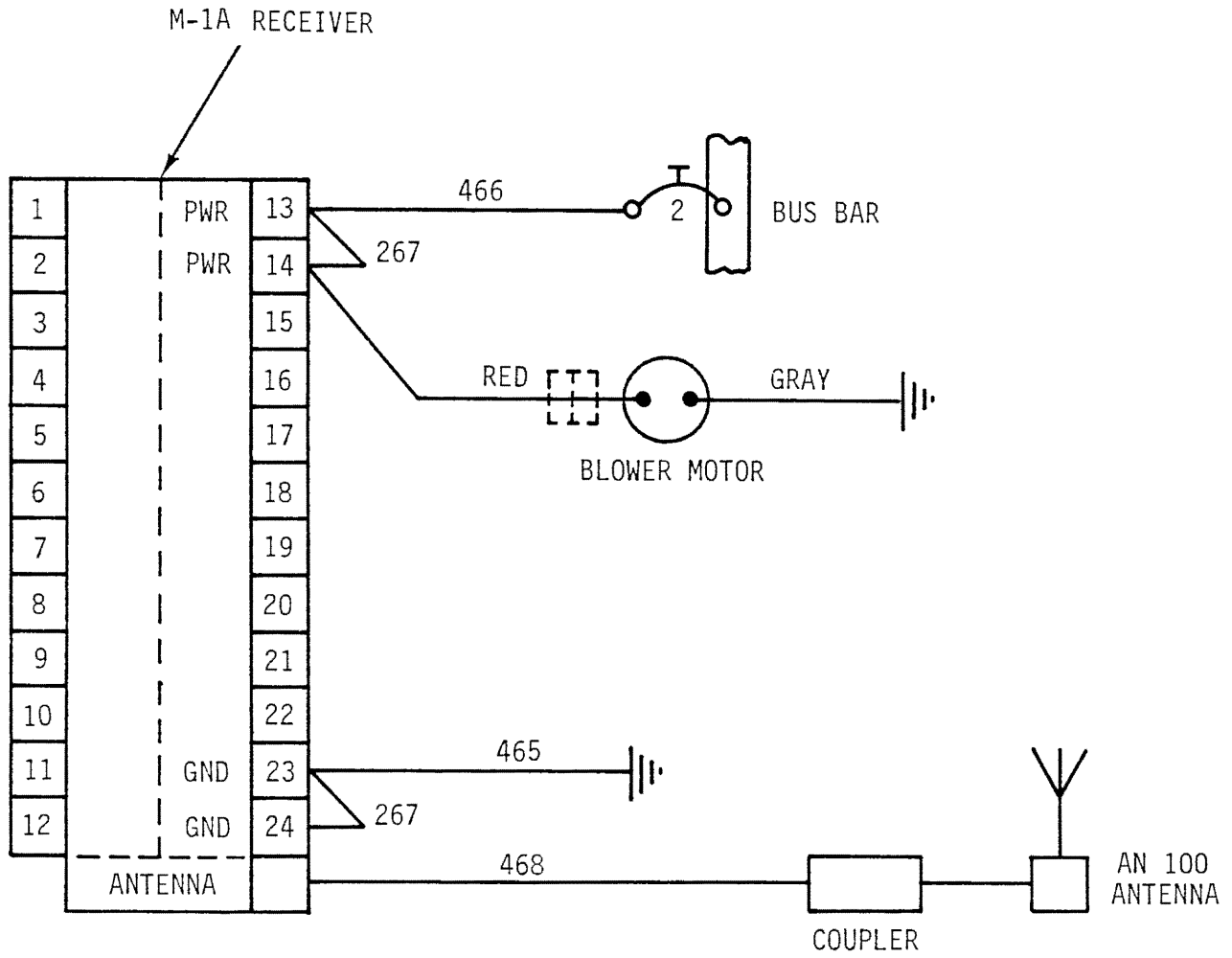

FIGURE 14-12 NORTHSTAR M-1A LORAN C RECEIVER

14.900 AVIONICS SCHEMATICS (Cont'd)

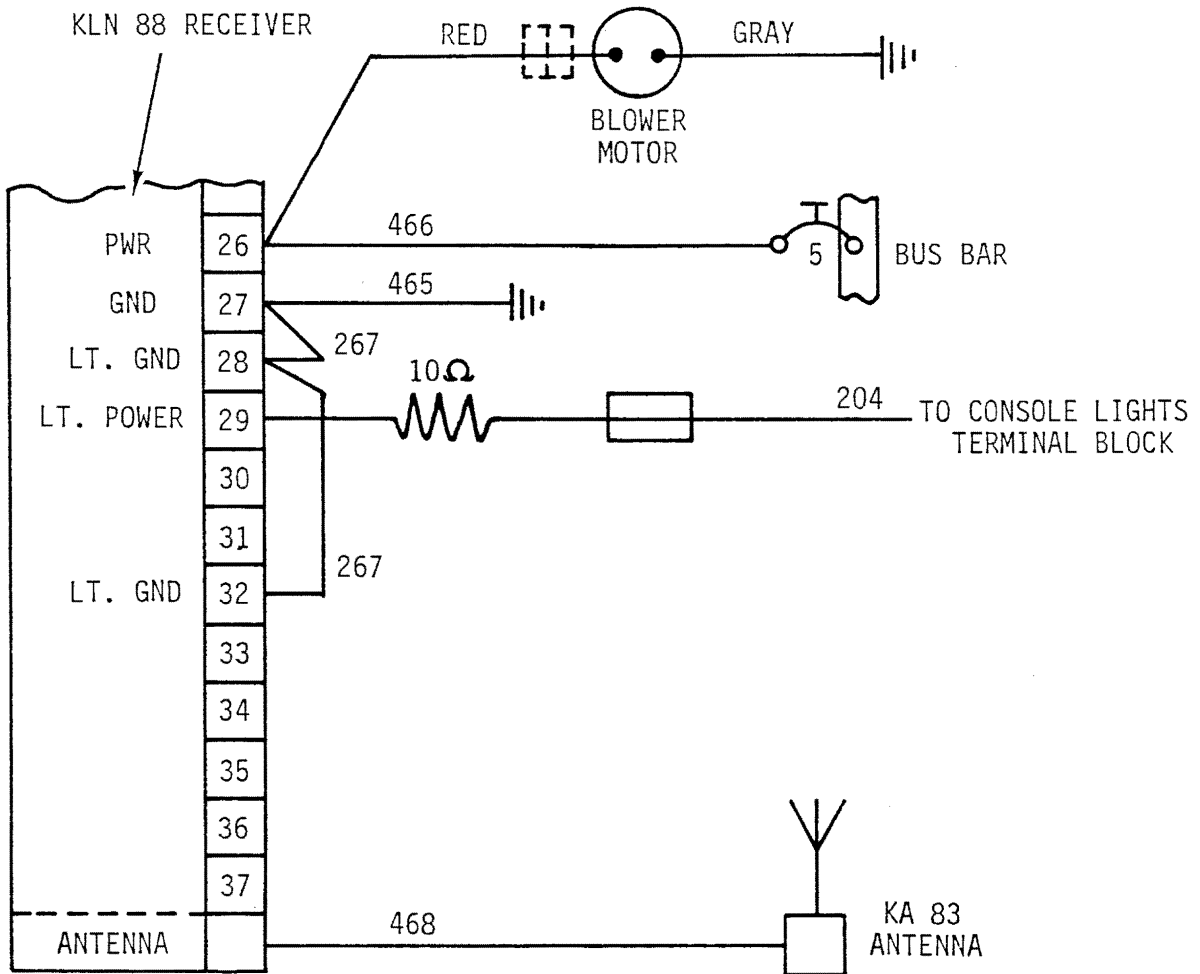

FIGURE 14-13 BENDIX/KING KLN 88 LORAN C RECEIVER

14.900 AVIONICS SCHEMATICS (Cont'd)

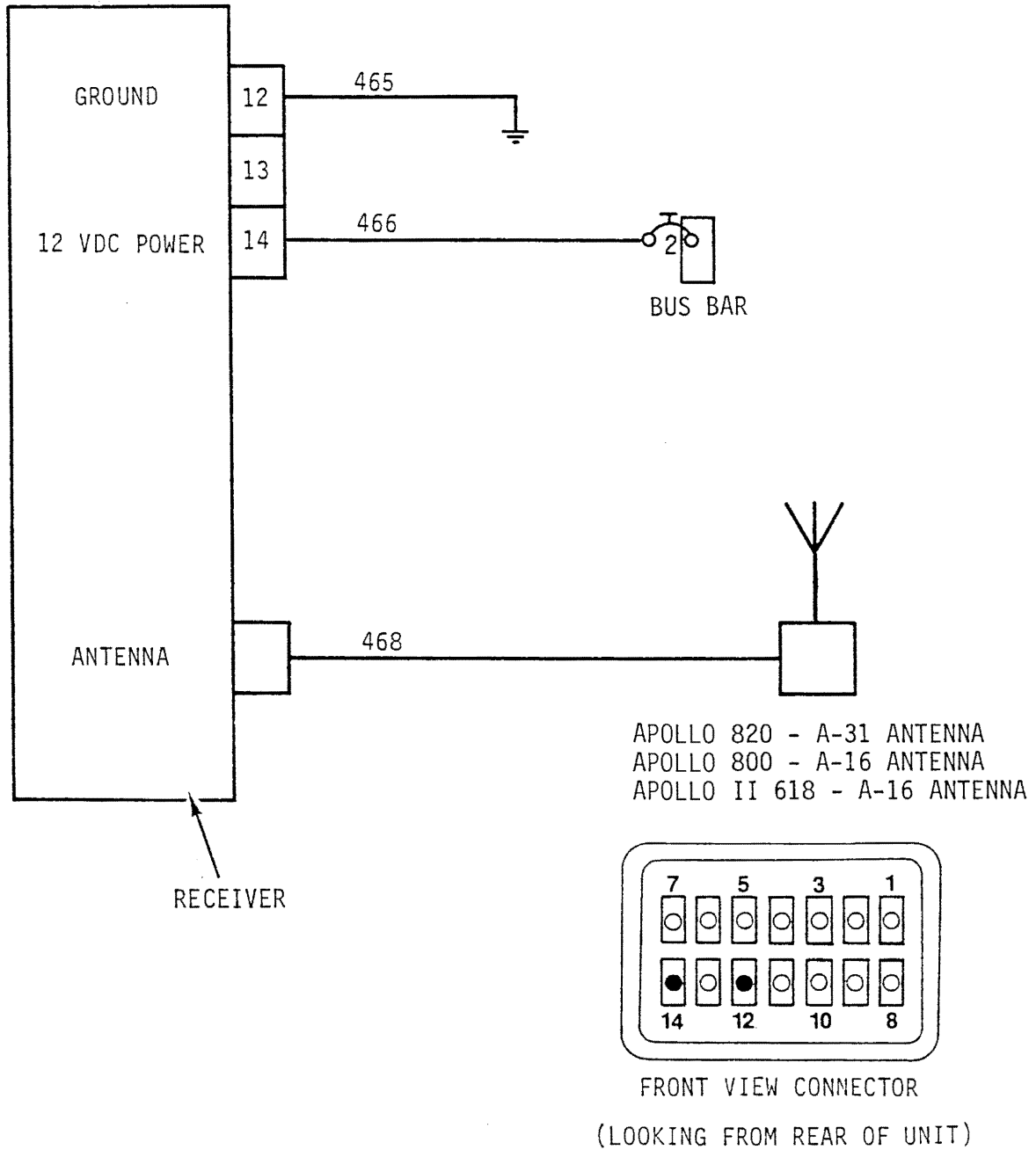

FIGURE 14- 14

APOLLO 820 FLYBUDDY GPS RECEIVER
 APOLLO 800 FLYBUDDY PLUS LORAN C RECEIVER
 APOLLO 618 TCA LORAN C RECEIVER

14.900 AVIONICS SCHEMATICS (Cont'd)

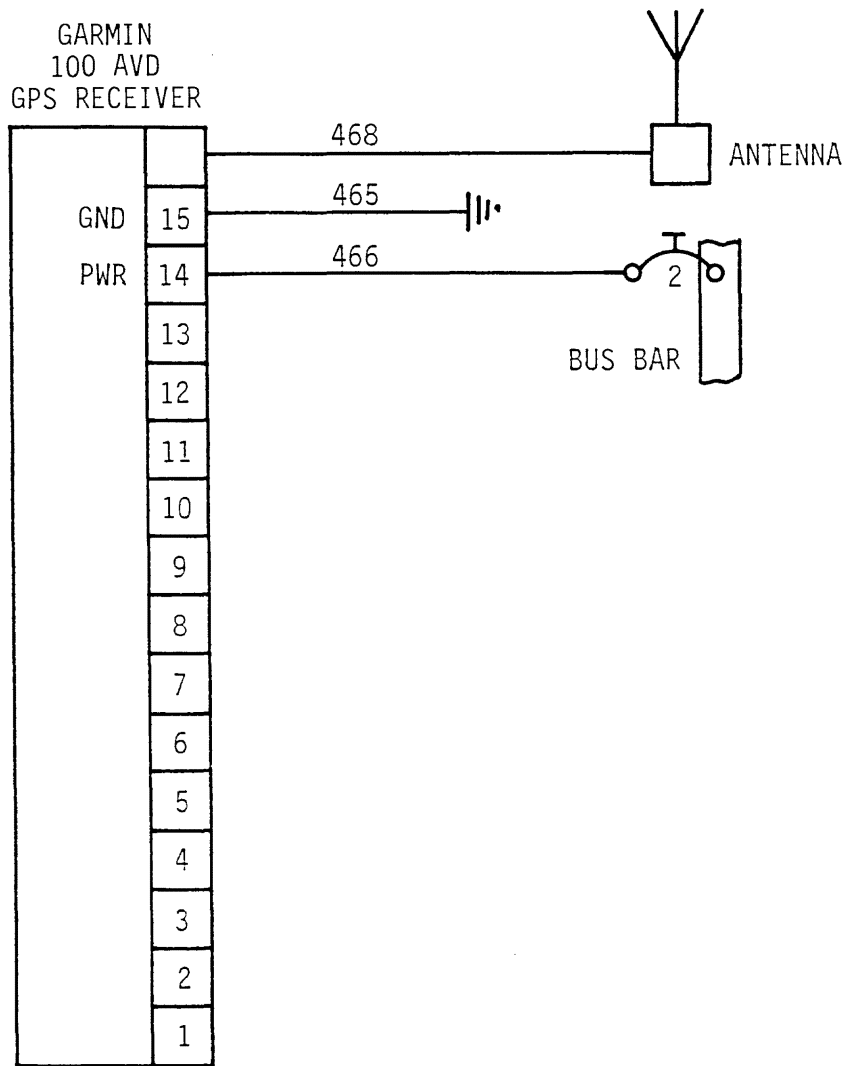

FIGURE 14-15 GARMIN 100 AVD GPS RECEIVER

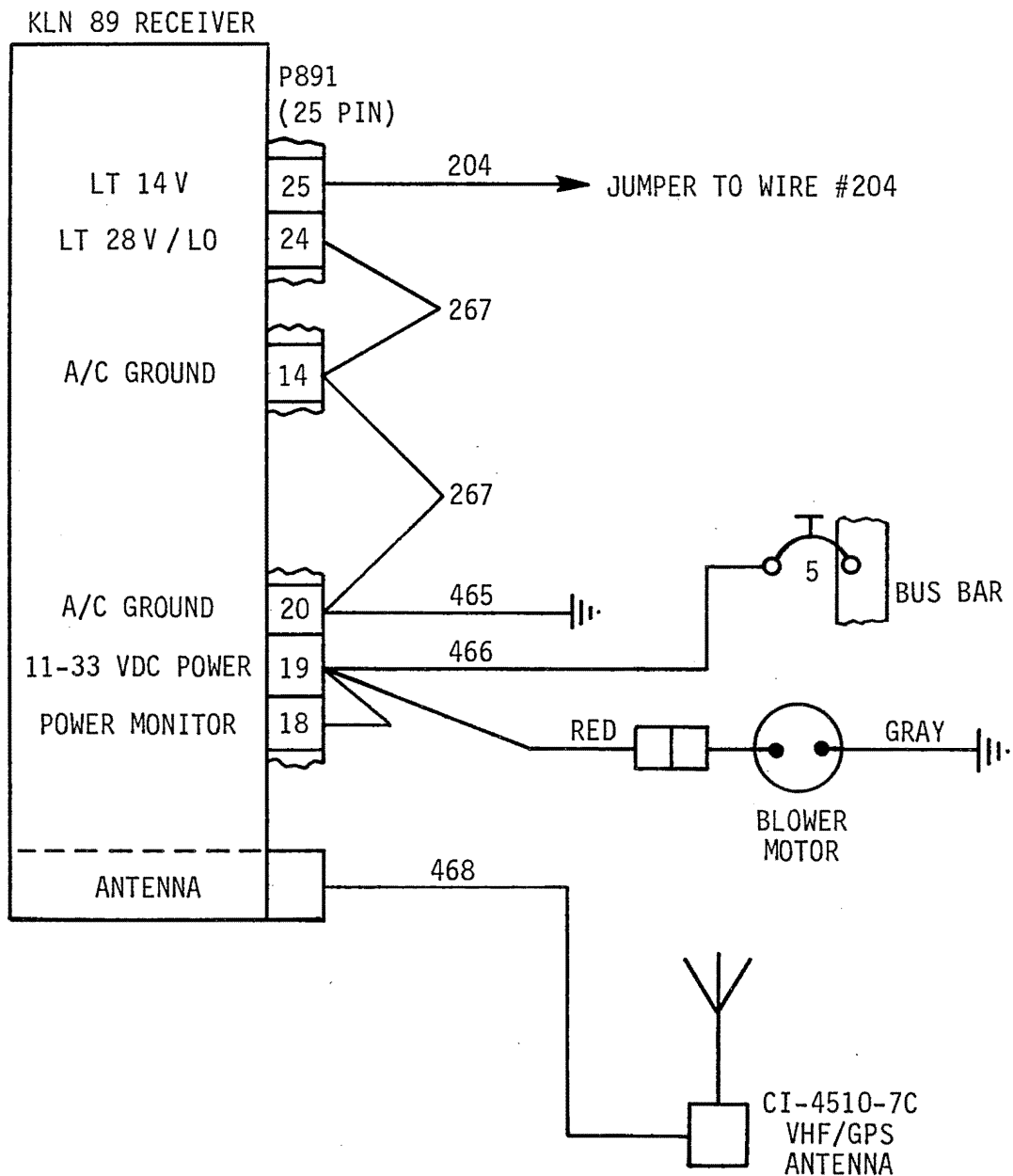

FIGURE 14-16 BENDIX/KING KLN 89 GPS RECEIVER

14.900 AVIONICS SCHEMATICS (Cont'd)

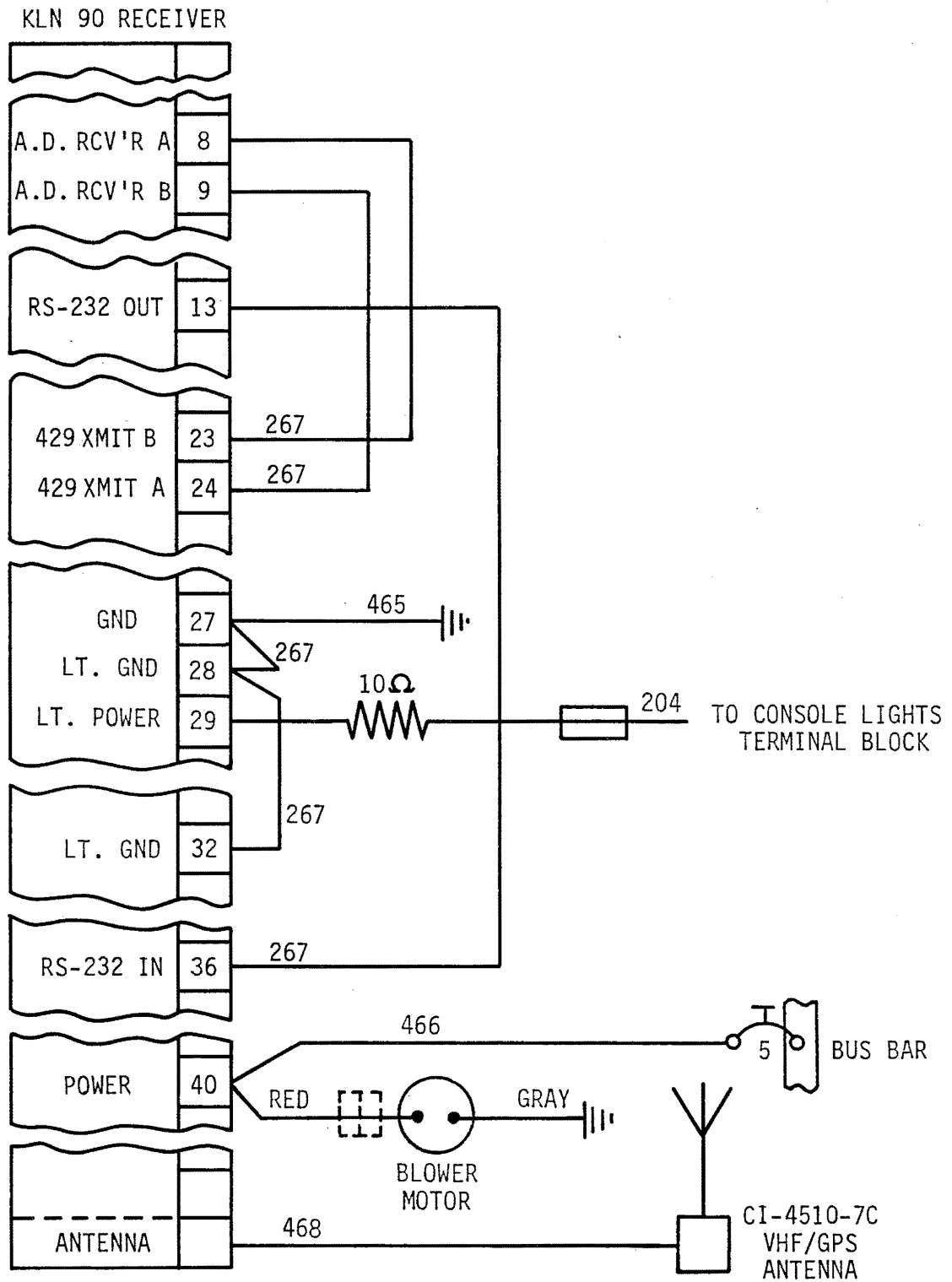
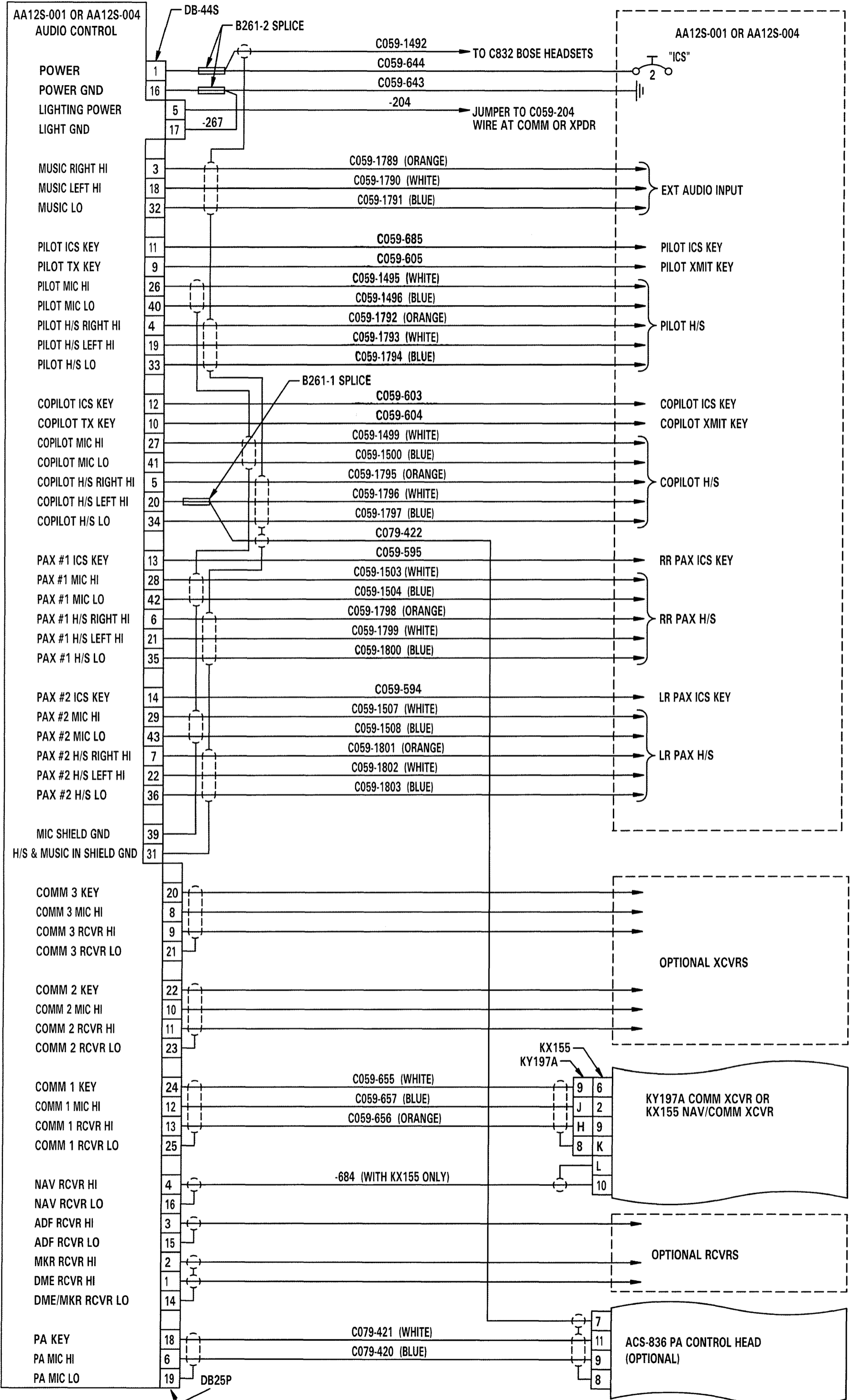

FIGURE 14-17 BENDIX/KING KLN 90 GPS RECEIVER

Change 13: OCT 2006

FIGURE 14-19 AA12S-002 or AA12S-005 AUDIO CONTROLLER



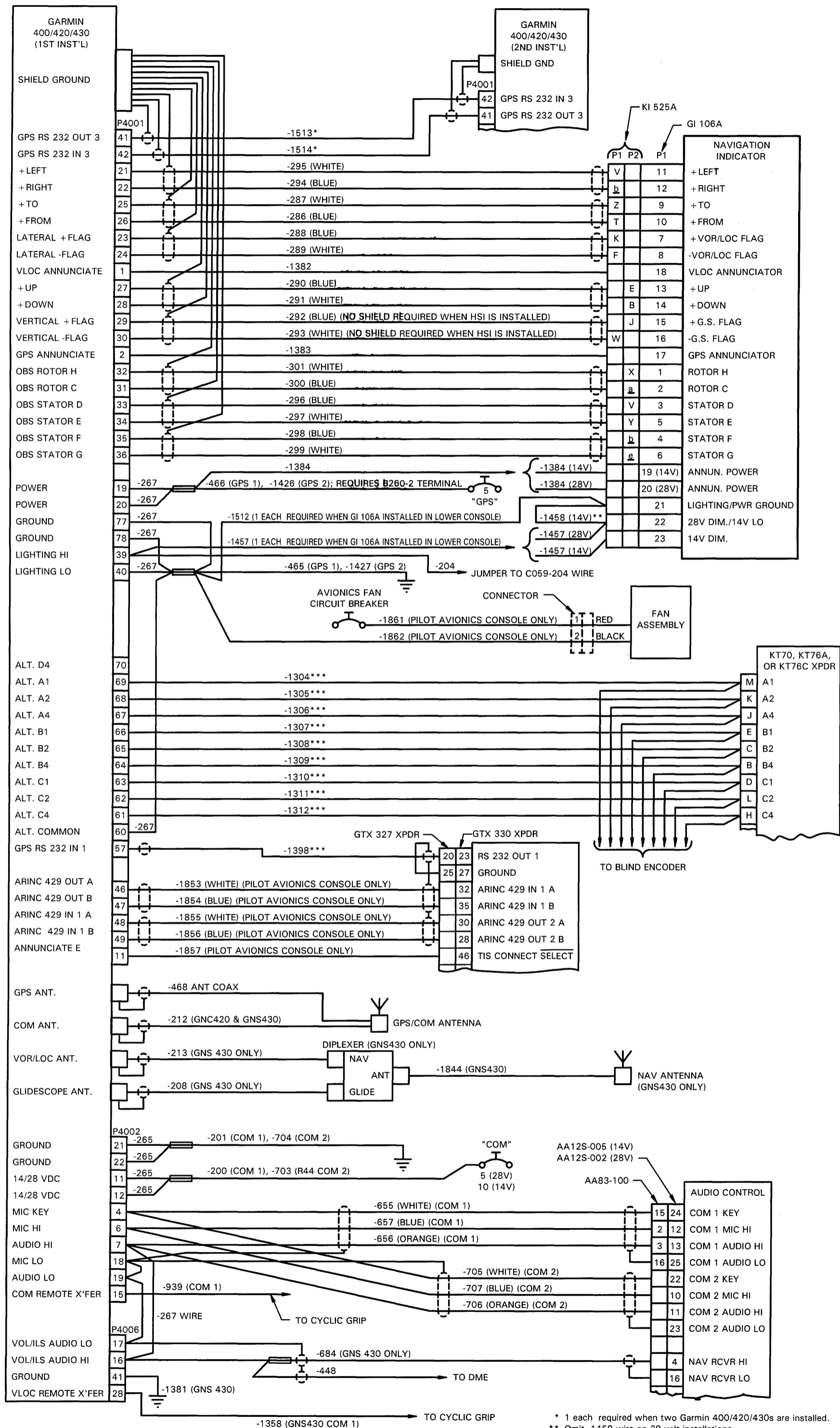

FIGURE 14-20 GARMIN 400/420/430 GPS

Change 13: OCT 2006

* 1 each required when two Garmin 400/420/430s are installed.
 ** Omit -1458 wire on 28-volt installations.
 *** Omit if used for GPS 2 installation.

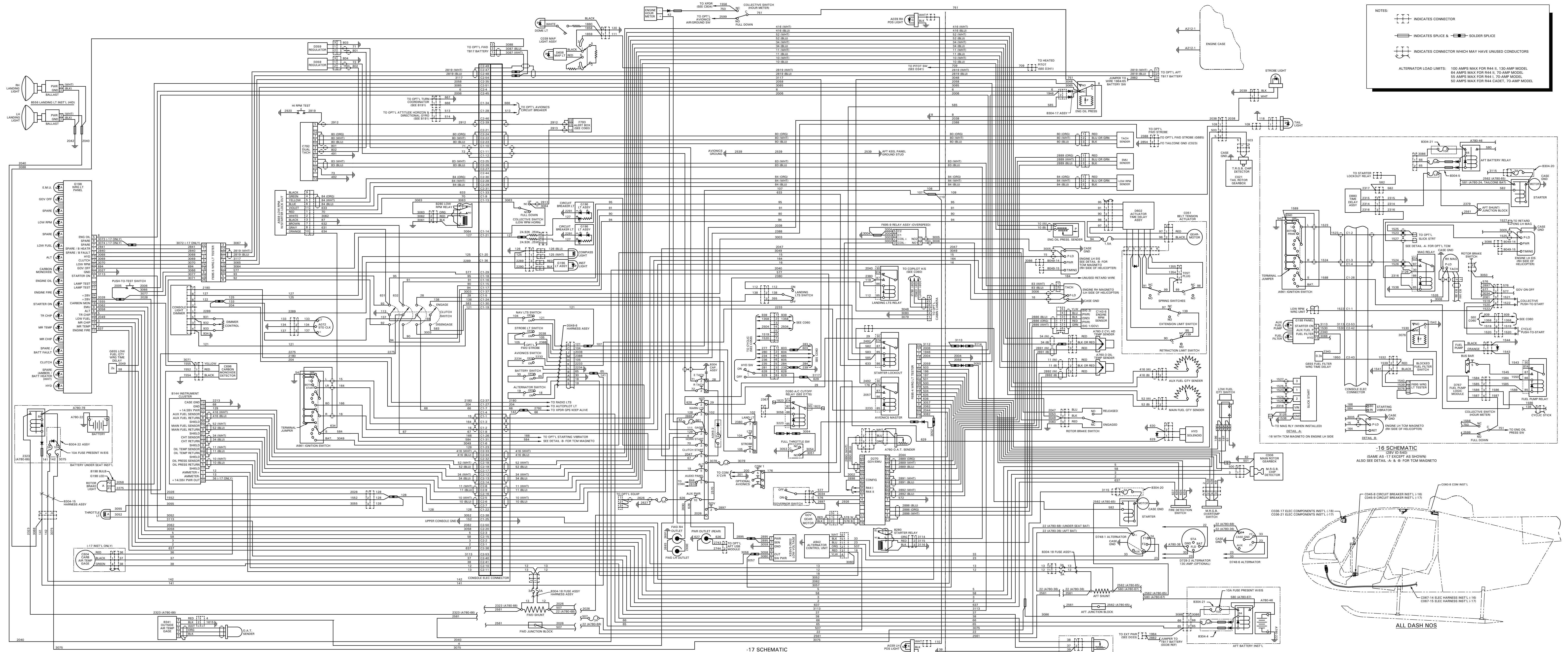

FIGURE 14-21 R44 ELECTRICAL SYSTEM INSTALLATION
(C024 Revision AT shown)

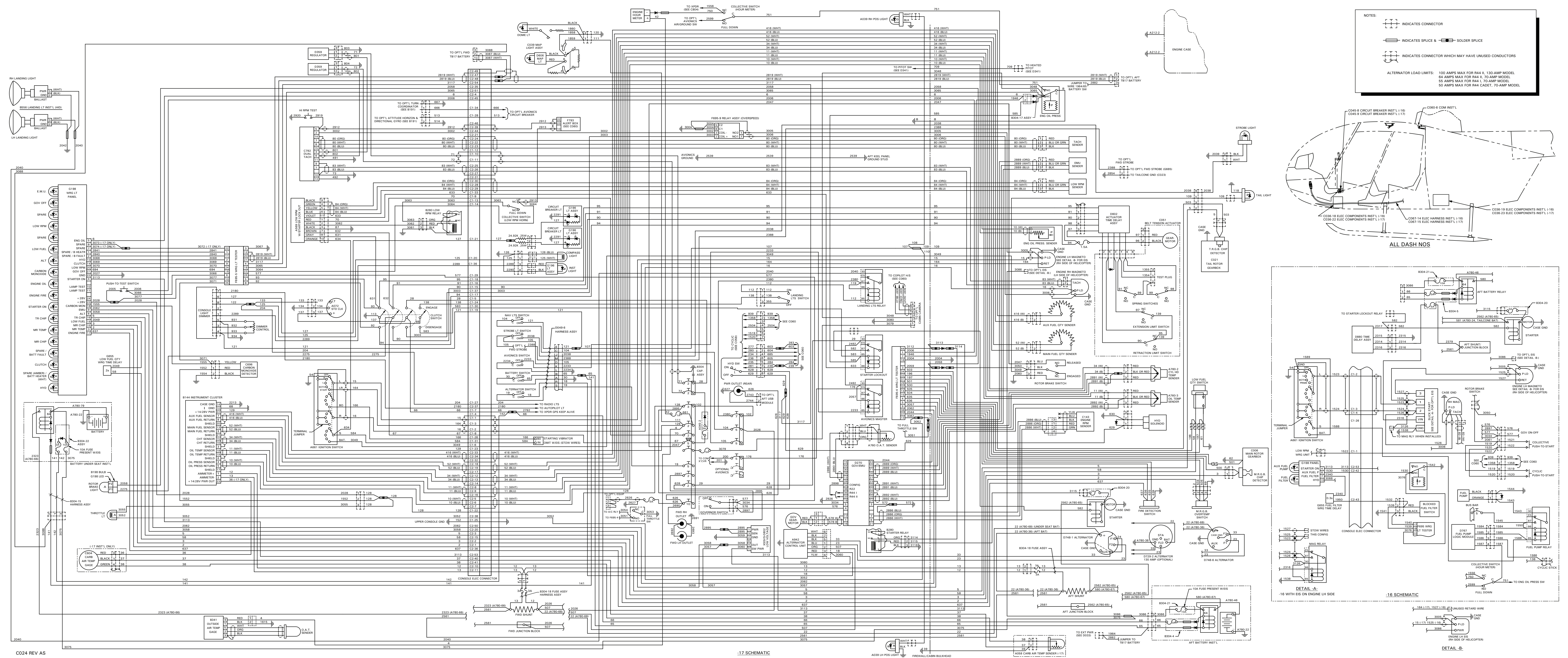

FIGURE 14-21A R44 ELECTRICAL SYSTEM INSTALLATION
(C024 Revision AS shown)

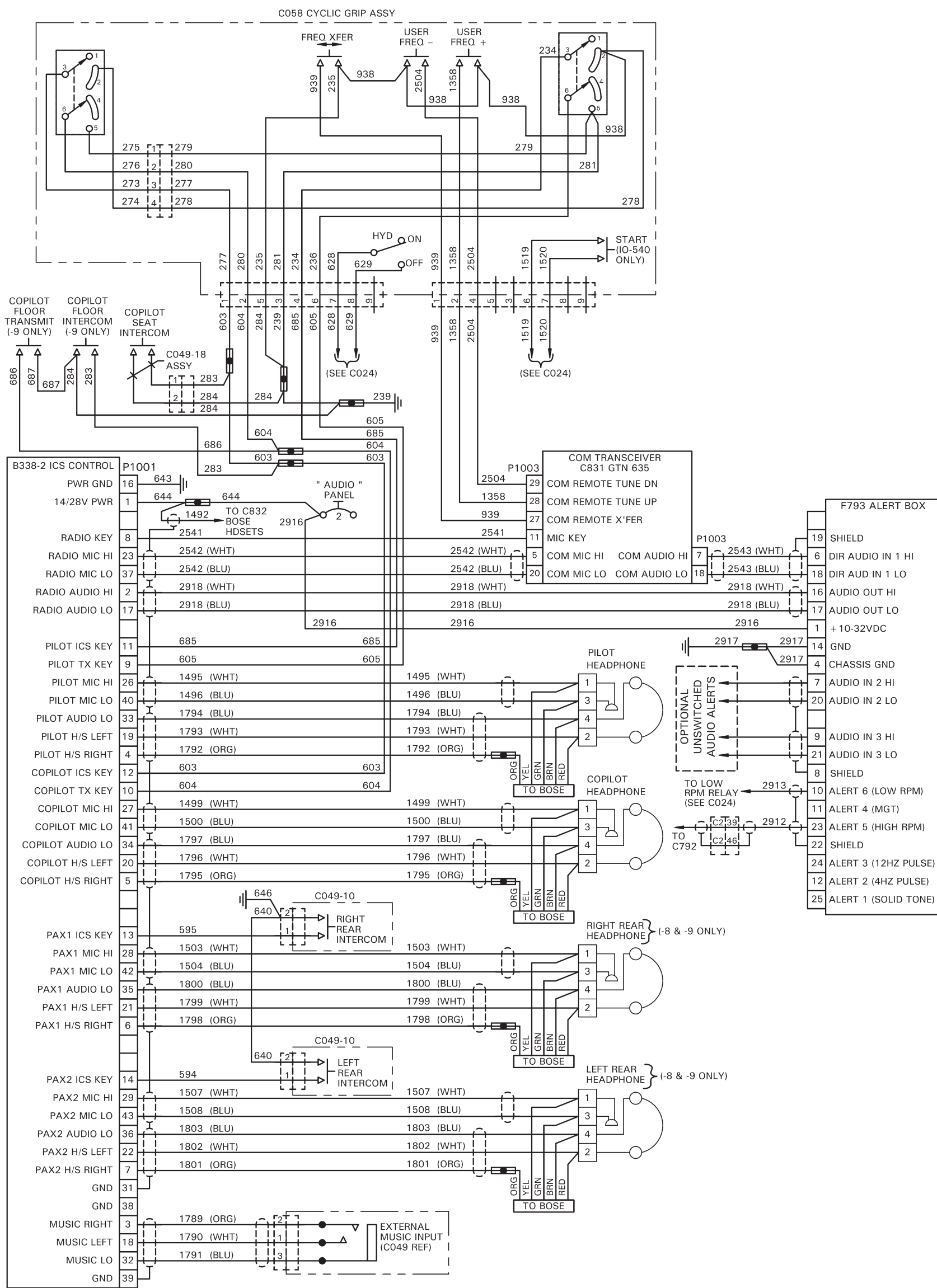
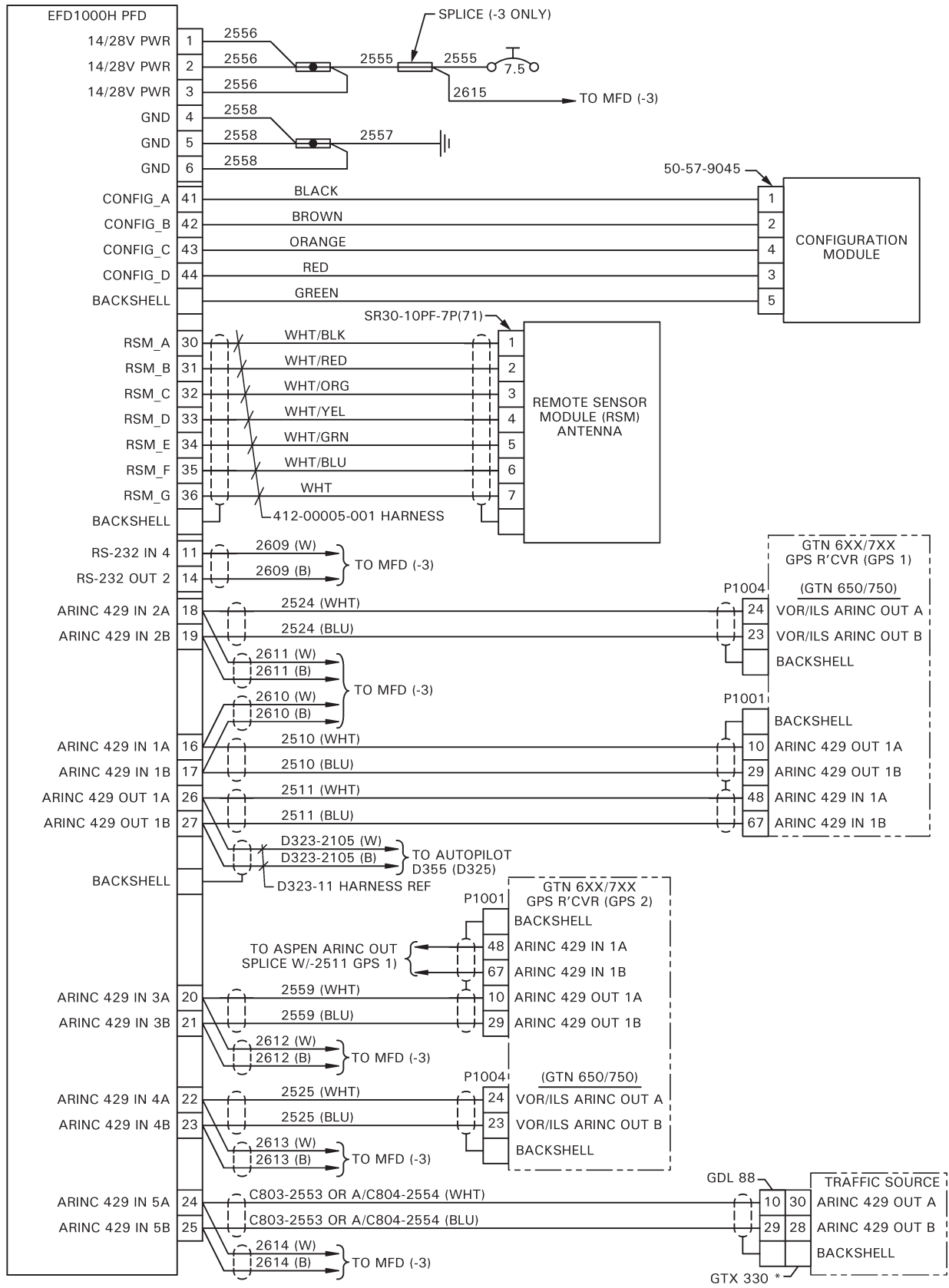

FIGURE 14-22 C060-8 THRU -10 AUDIO SYSTEM & INTERIOR LIGHT SCHEMATIC

C060 REV AC

Intentionally Blank



C800 REV E

* Connect to GTX 330 traffic (TIS-A) ONLY if no other traffic system installed, such as GDL 88 (TIS-B).

FIGURE 14-23 C800-1 ASPEN PFD

Intentionally Blank

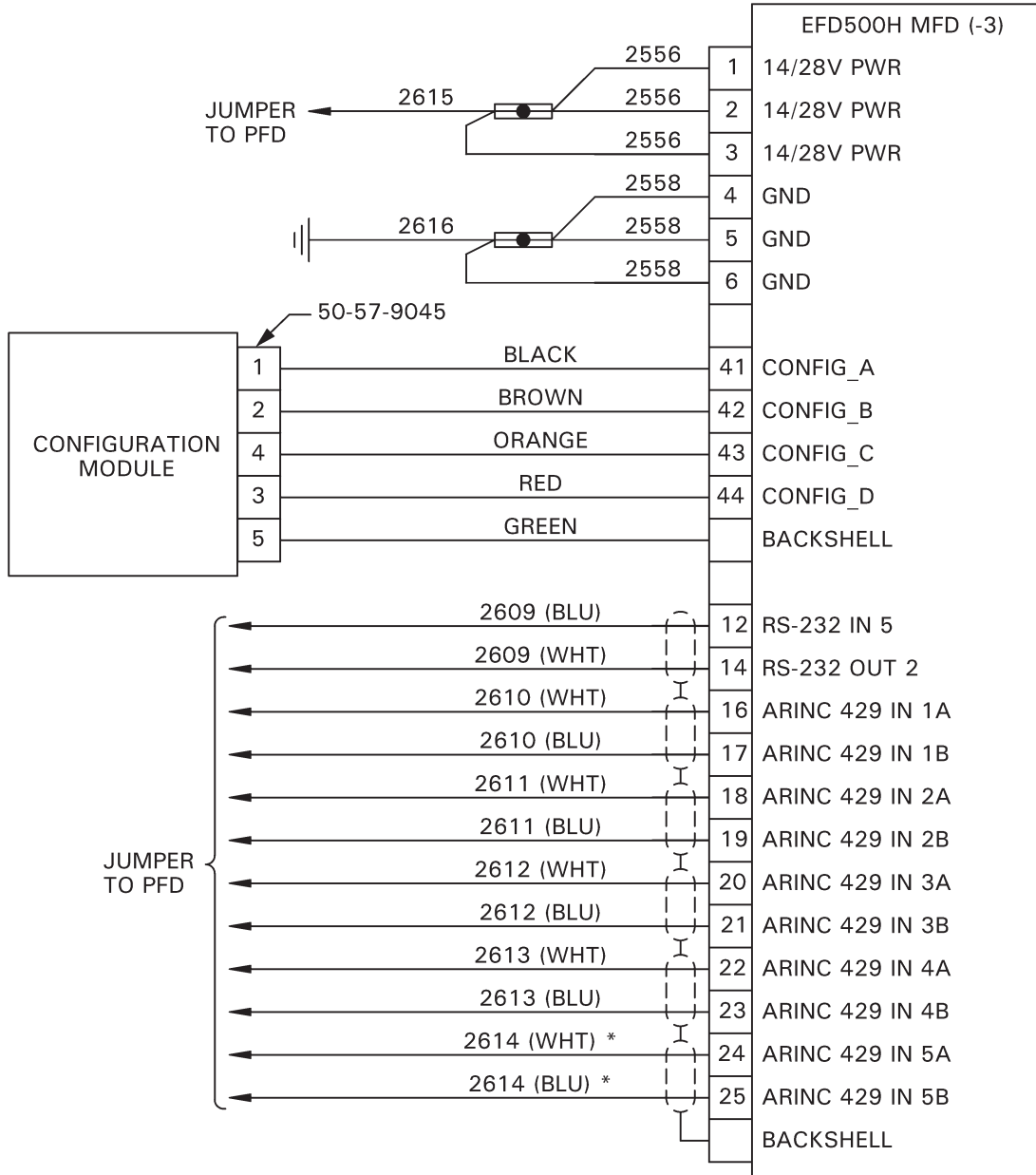

C800 REV E

FIGURE 14-24 C800-3 ASPEN PFD & MFD

Intentionally Blank

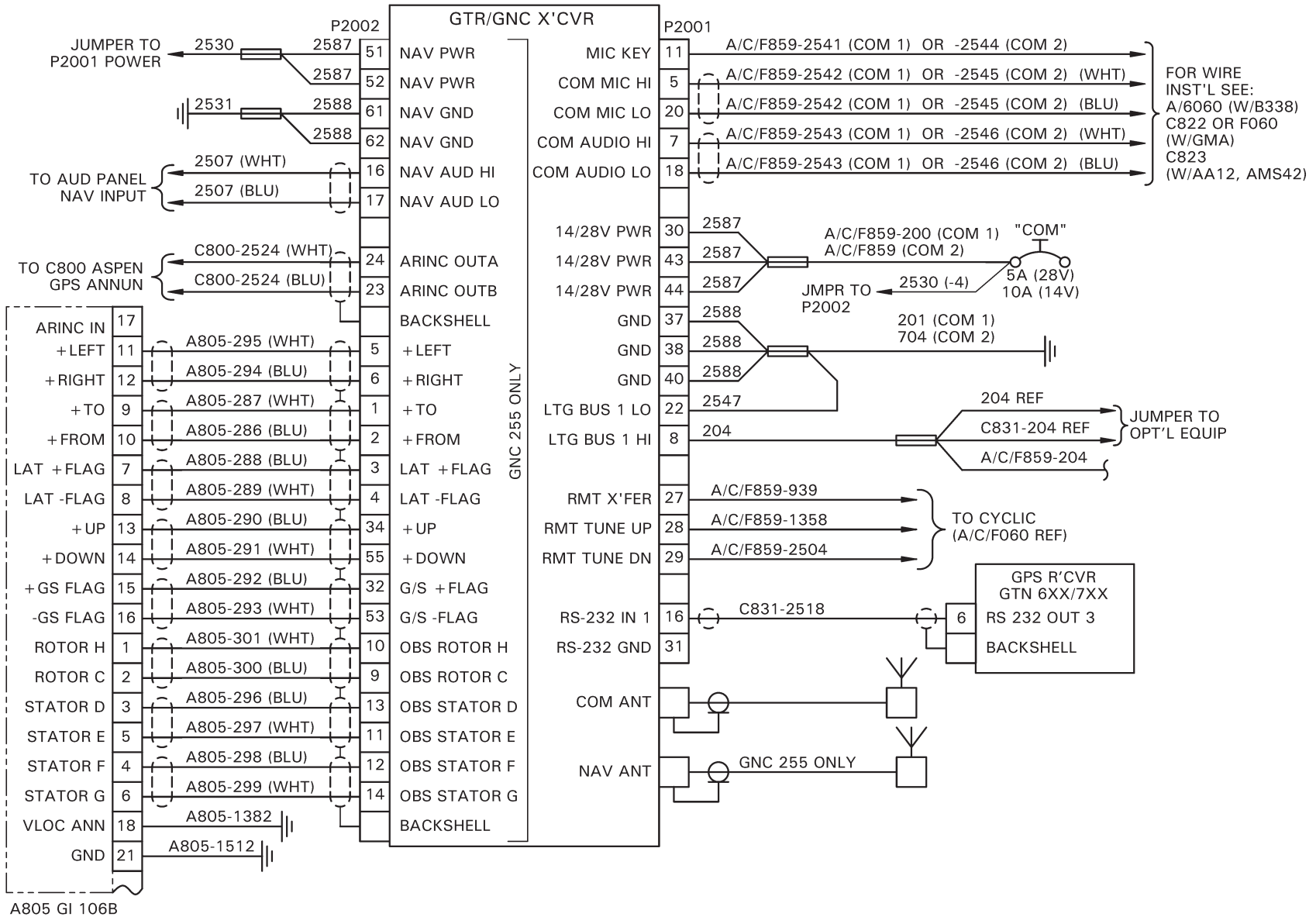
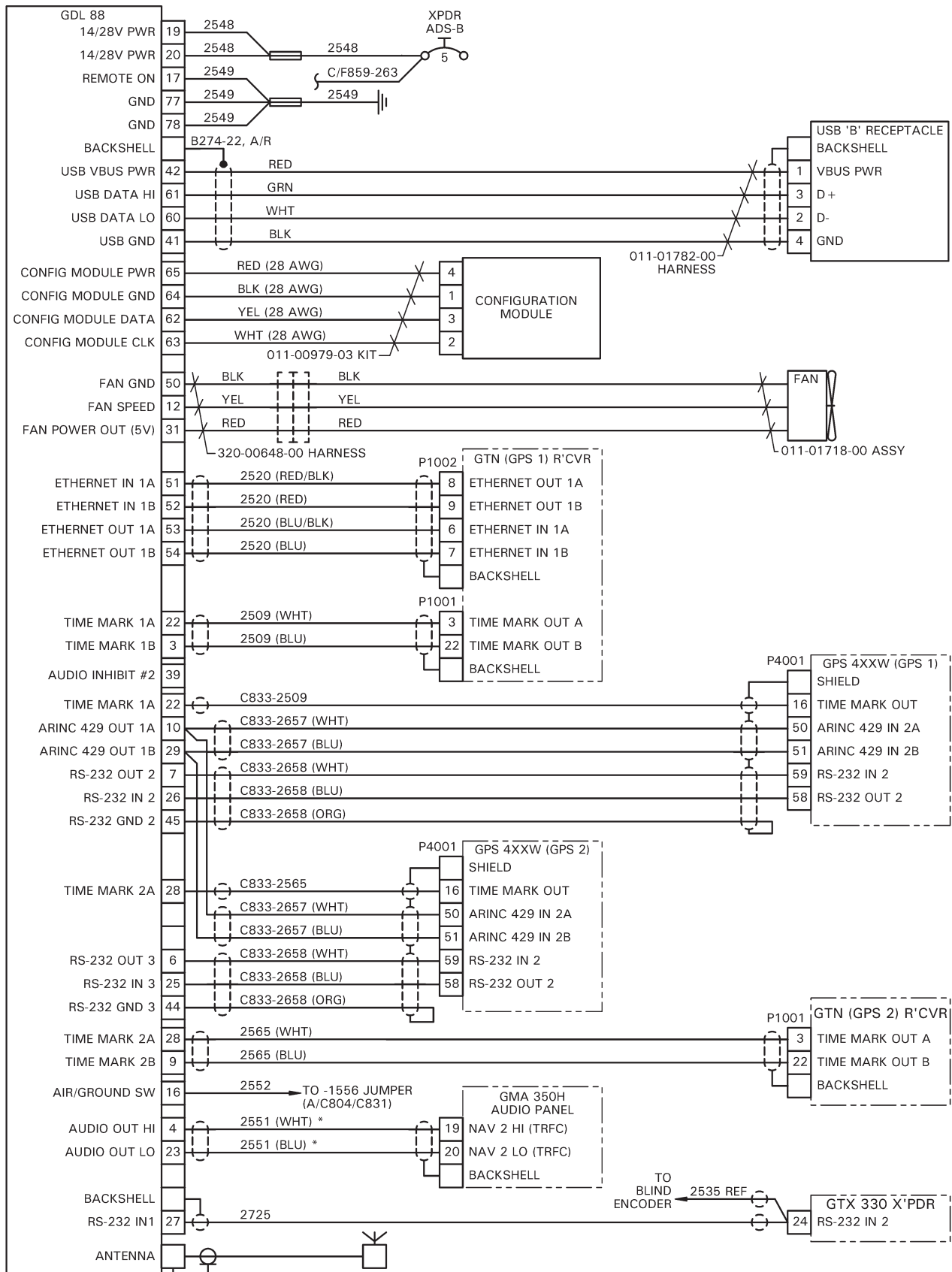

FIGURE 14-25 C802-2 AND -4 COM INSTALLATION (GTR 225B AND GNC 255B, NAV/COM)

C802 REV F

Intentionally Blank



C803 REV D

* GDL 88 traffic wiring is in lieu of GTX 330 traffic wiring.

FIGURE 14-26 C803-1 AND -3 ADS-B INSTALLATION (GDL 88)

Intentionally Blank

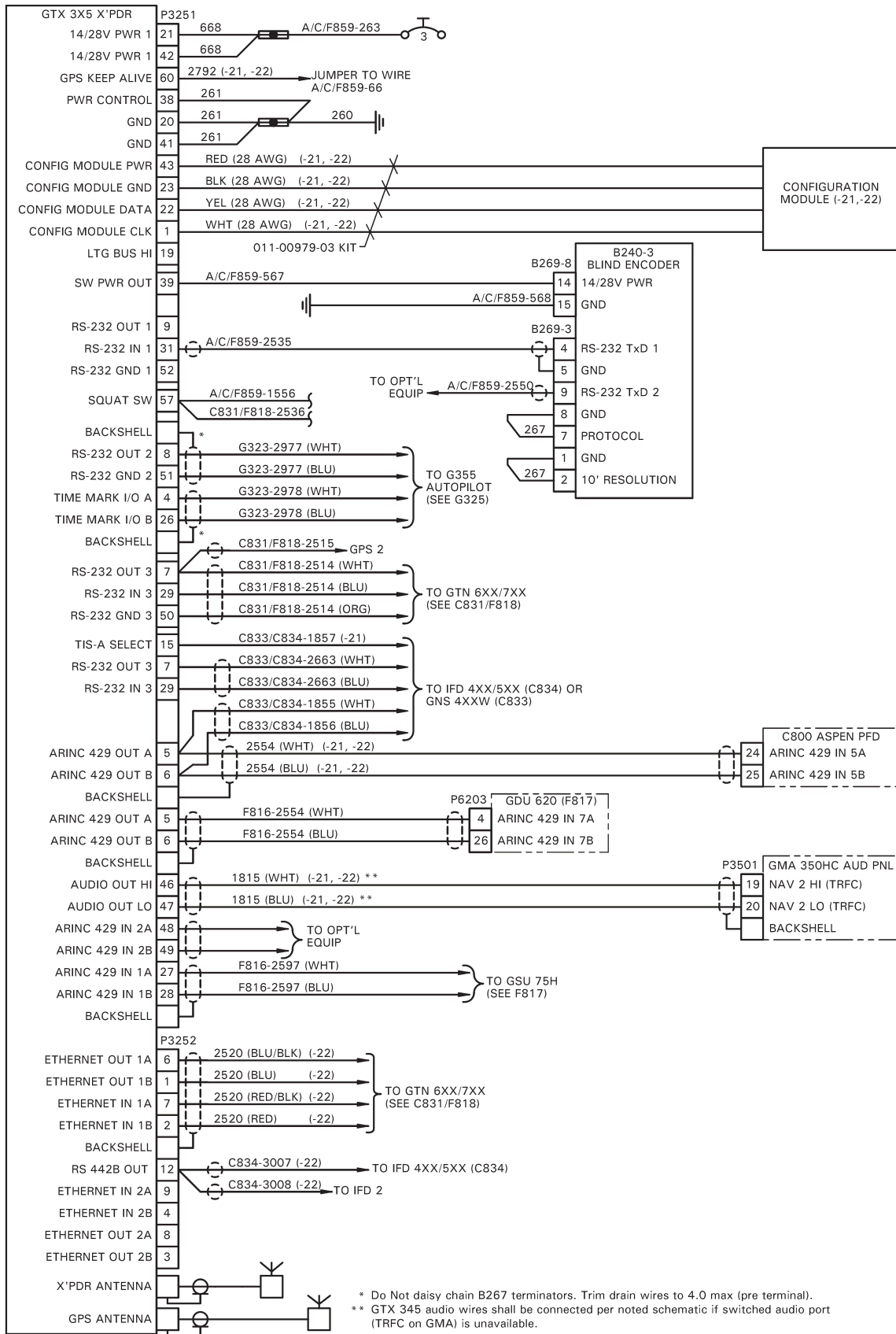

C804 REV AC

FIGURE 14-27 C804-20, -21, AND -22 TRANSPONDER INSTALLATION (GTX 325, GTX 335, GTX 345)

Intentionally Blank

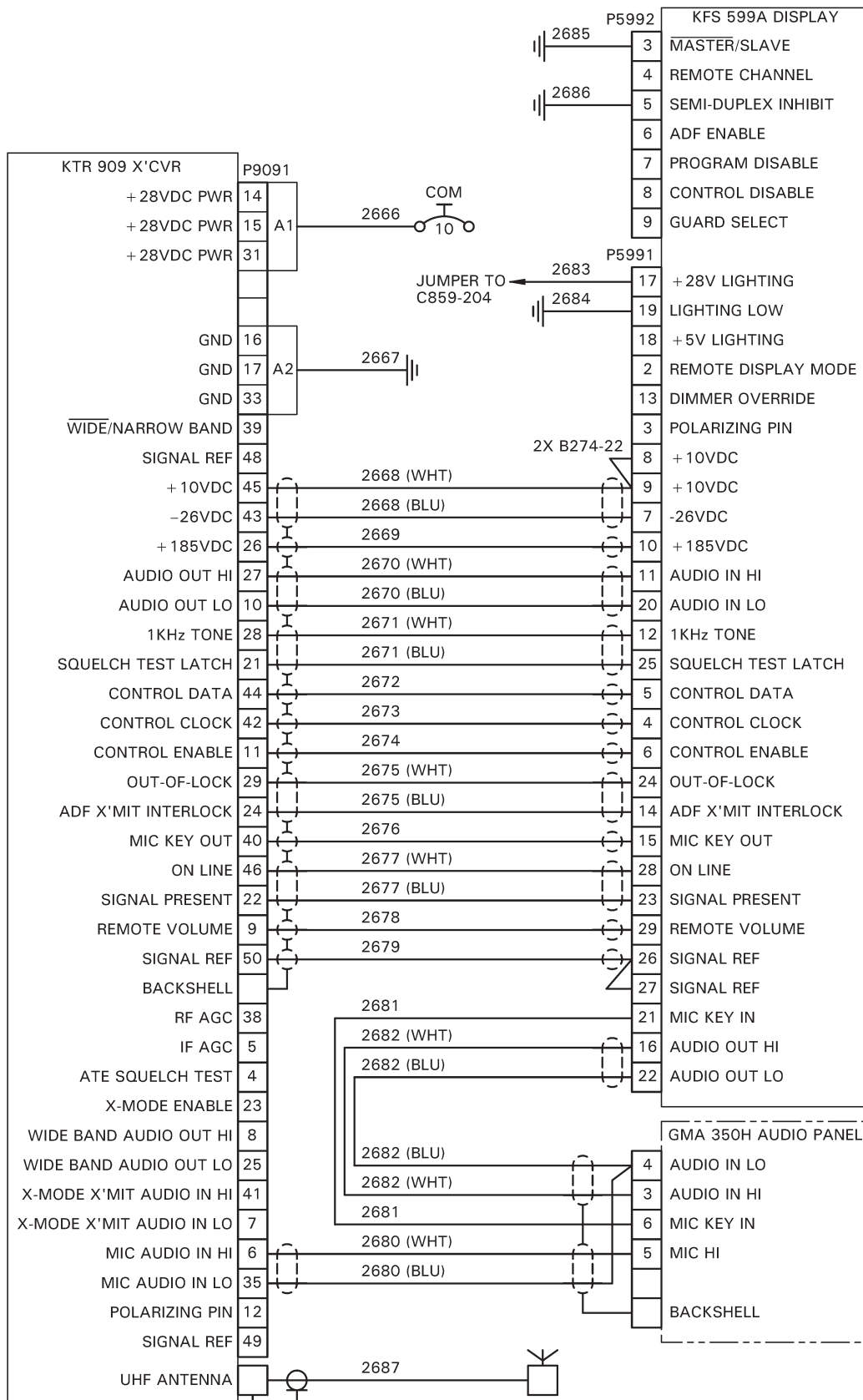

C807 REV B

FIGURE 14-28 C807-1 TRANSCEIVER INSTALLATION (KING KTR 909 UHF)

Intentionally Blank

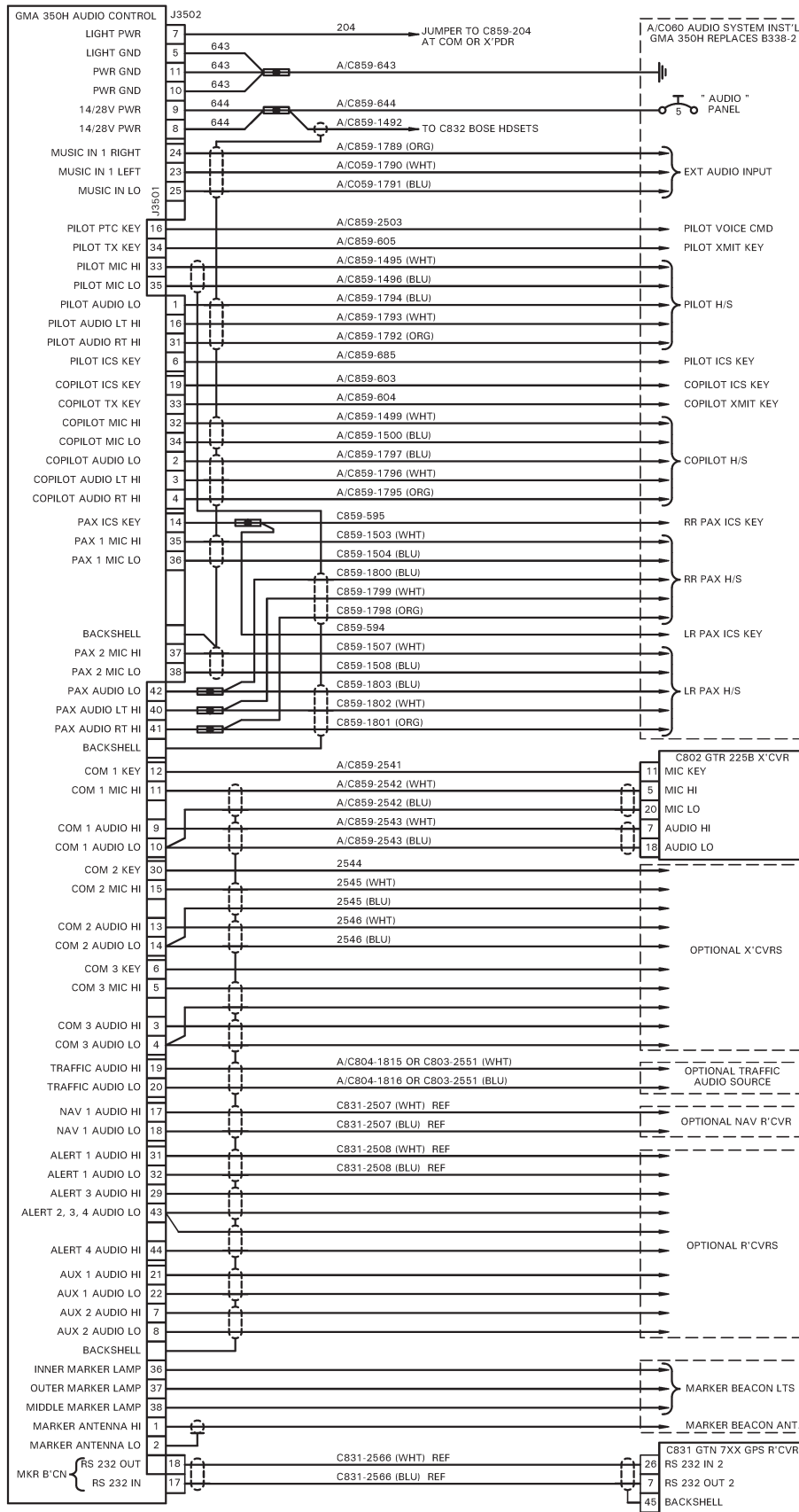

C822 REV C

FIGURE 14-29 C822-2 AUDIO CONTROL INSTALLATION (GMA 350H)

Intentionally Blank

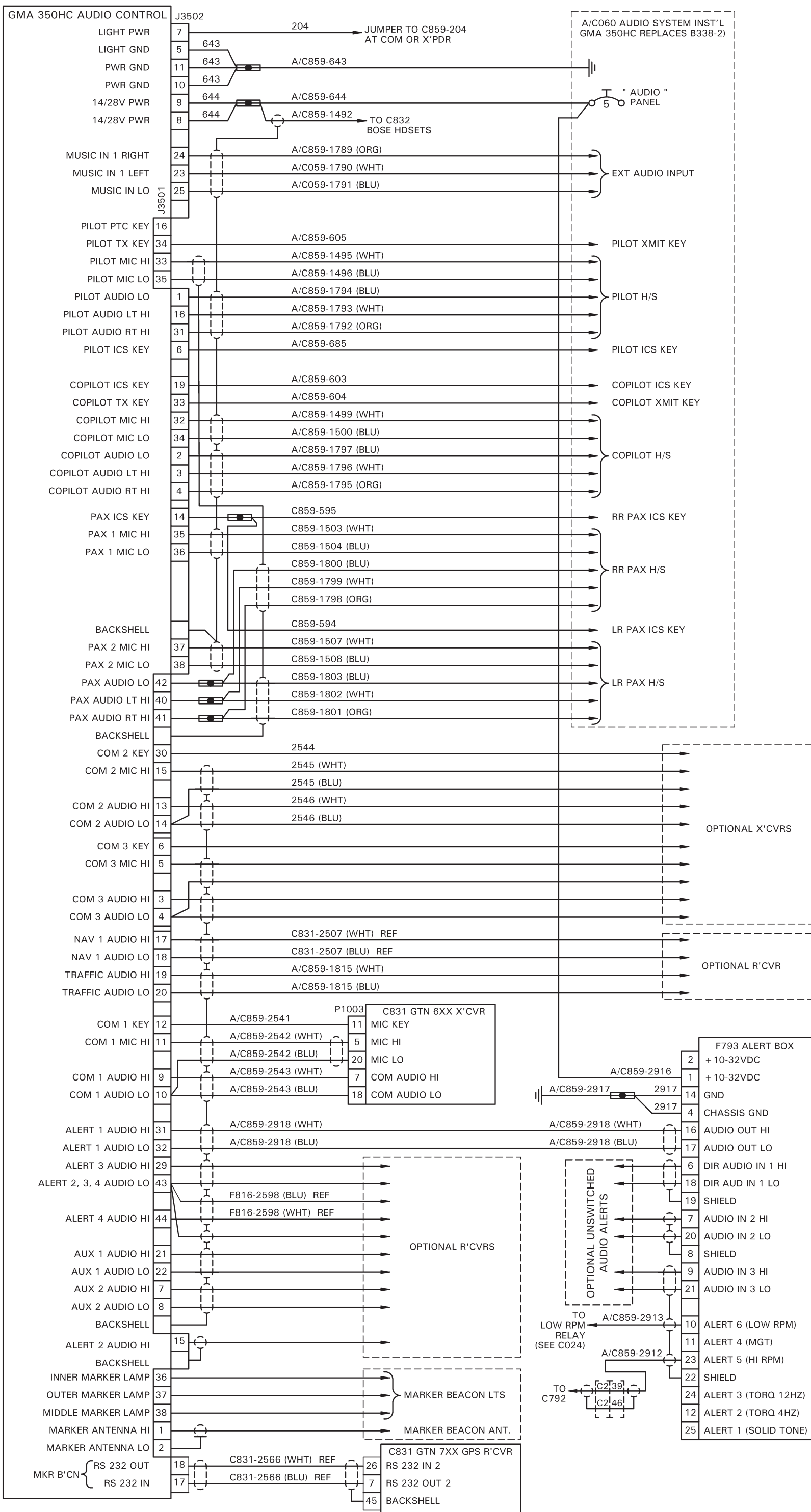

Intentionally Blank

FIGURE 14-31 C831-4 THRU -11 GPS INSTALLATION (GTN 6XX/7XX, PILOT AVIONICS CONSOLE)

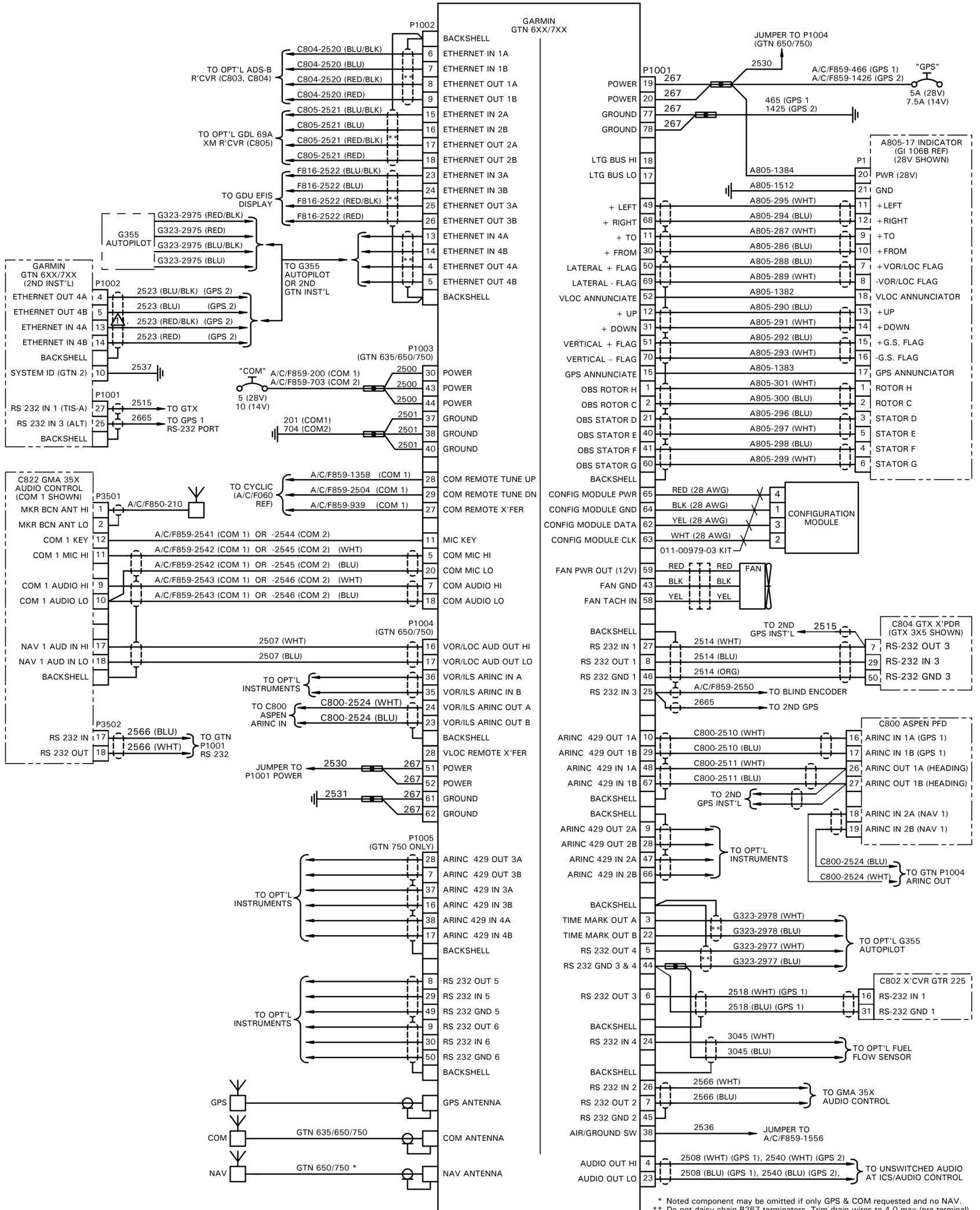

C831 REV I

Intentionally Blank

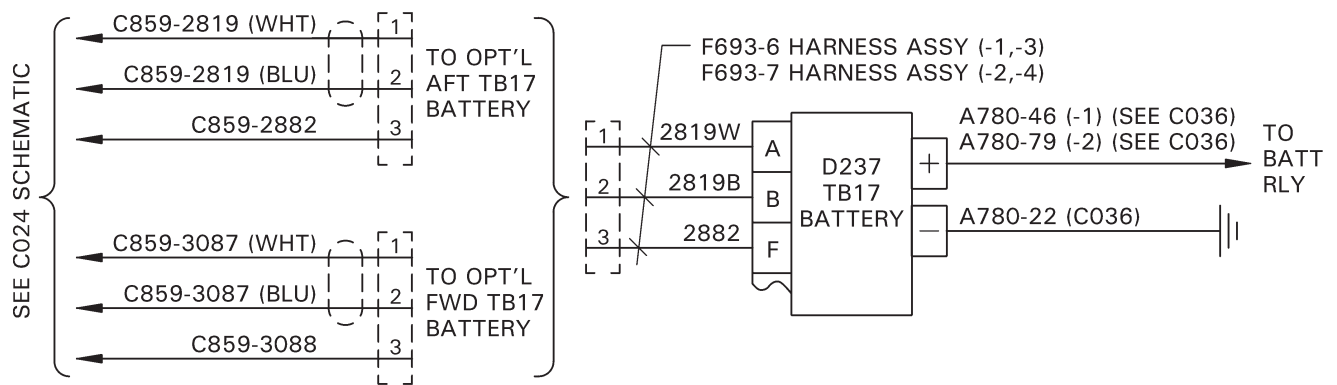

D036 REV C

FIGURE 14-31A D036 LITHIUM-ION BATTERY INSTALLATION

Intentionally Blank

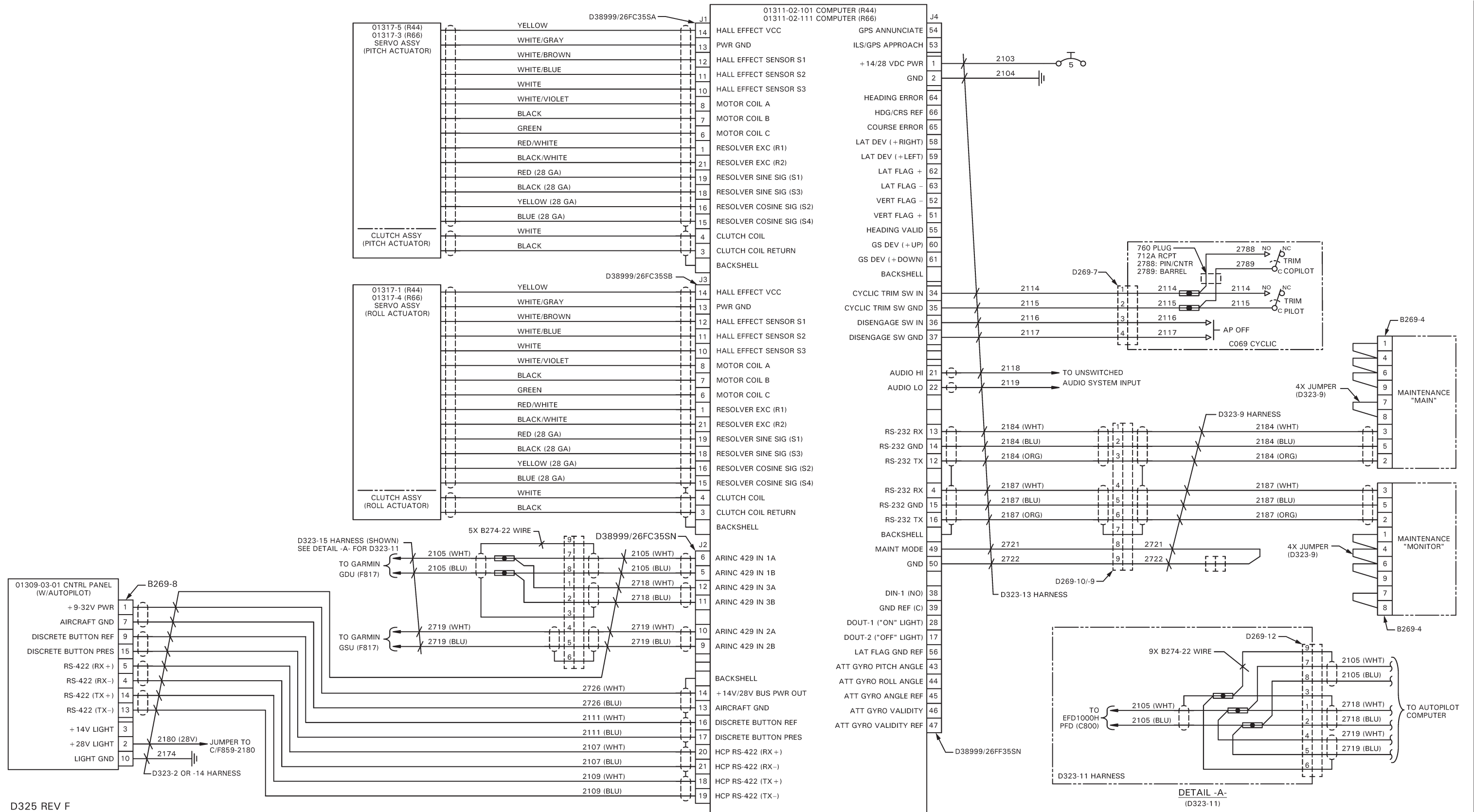

FIGURE 14-32A D325-1 AUTOPILOT (HELISAS, WITHOUT BC MODE) SCHEMATIC

D325 REV F

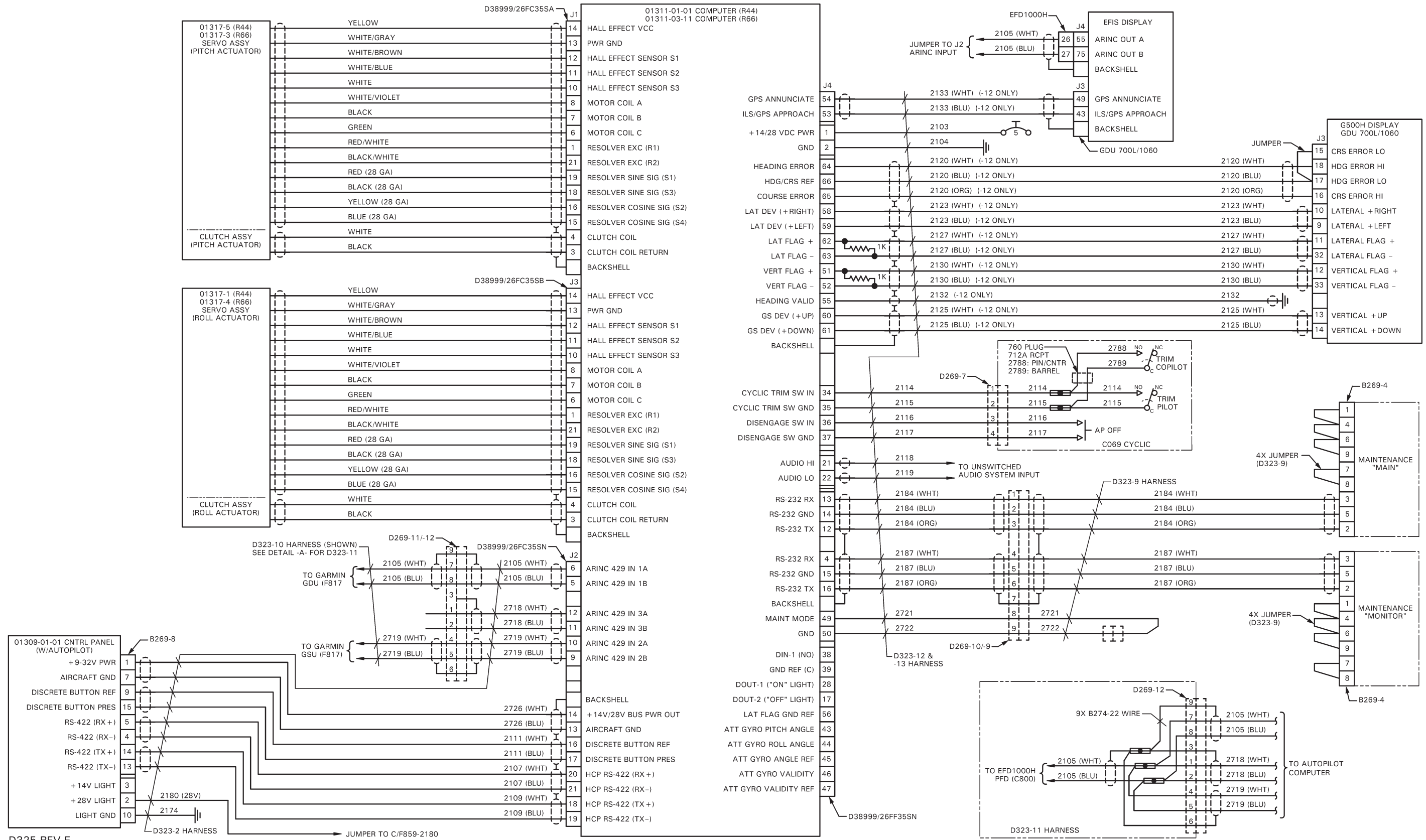
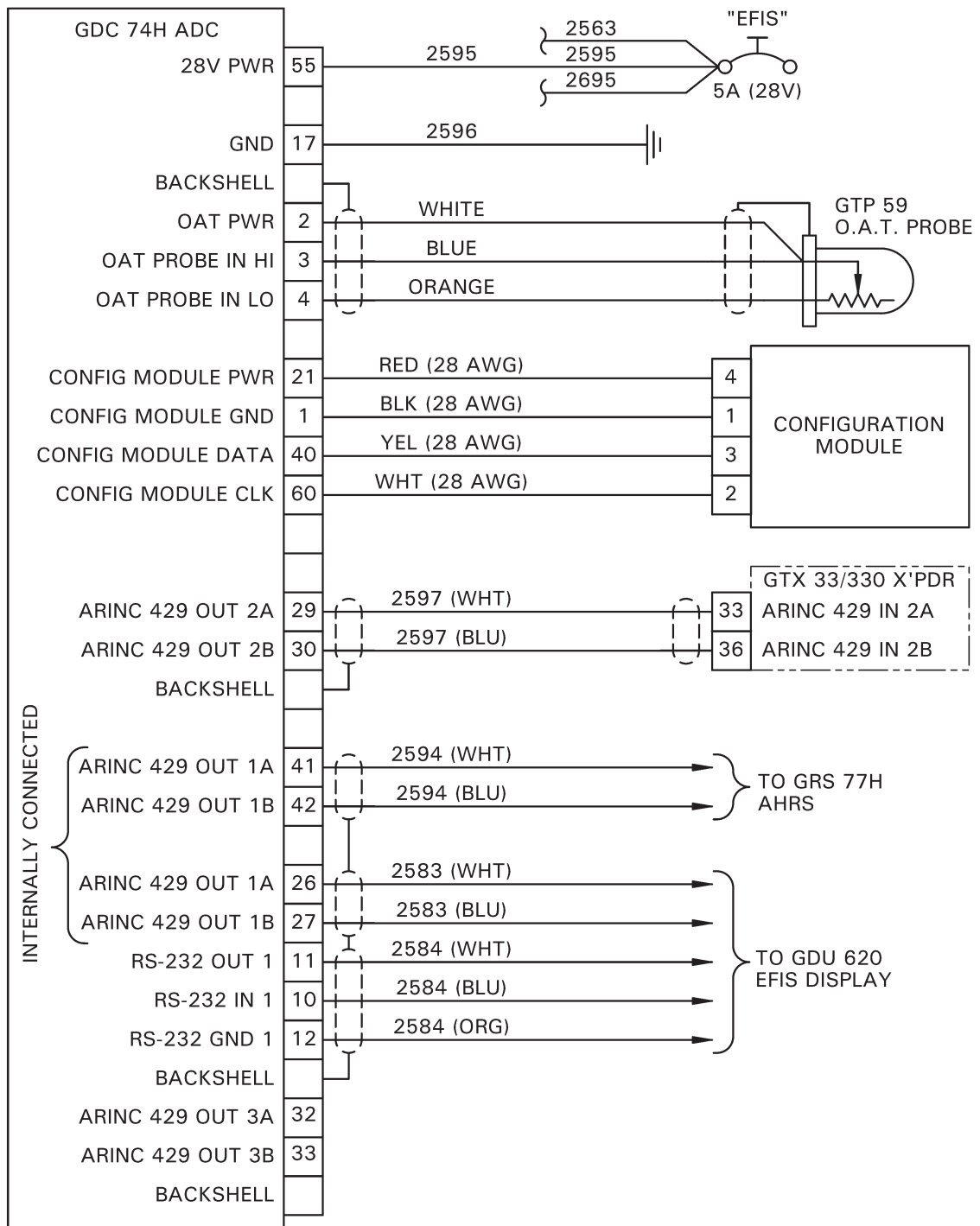

FIGURE 14-32B D325-1 AUTOPILOT (HELISAS, WITH BC MODE) SCHEMATIC



F817 REV E

FIGURE 14-33 F817-1 G500H LRU INSTALLATION – GDC 74H AIR DATA COMPUTER

Intentionally Blank

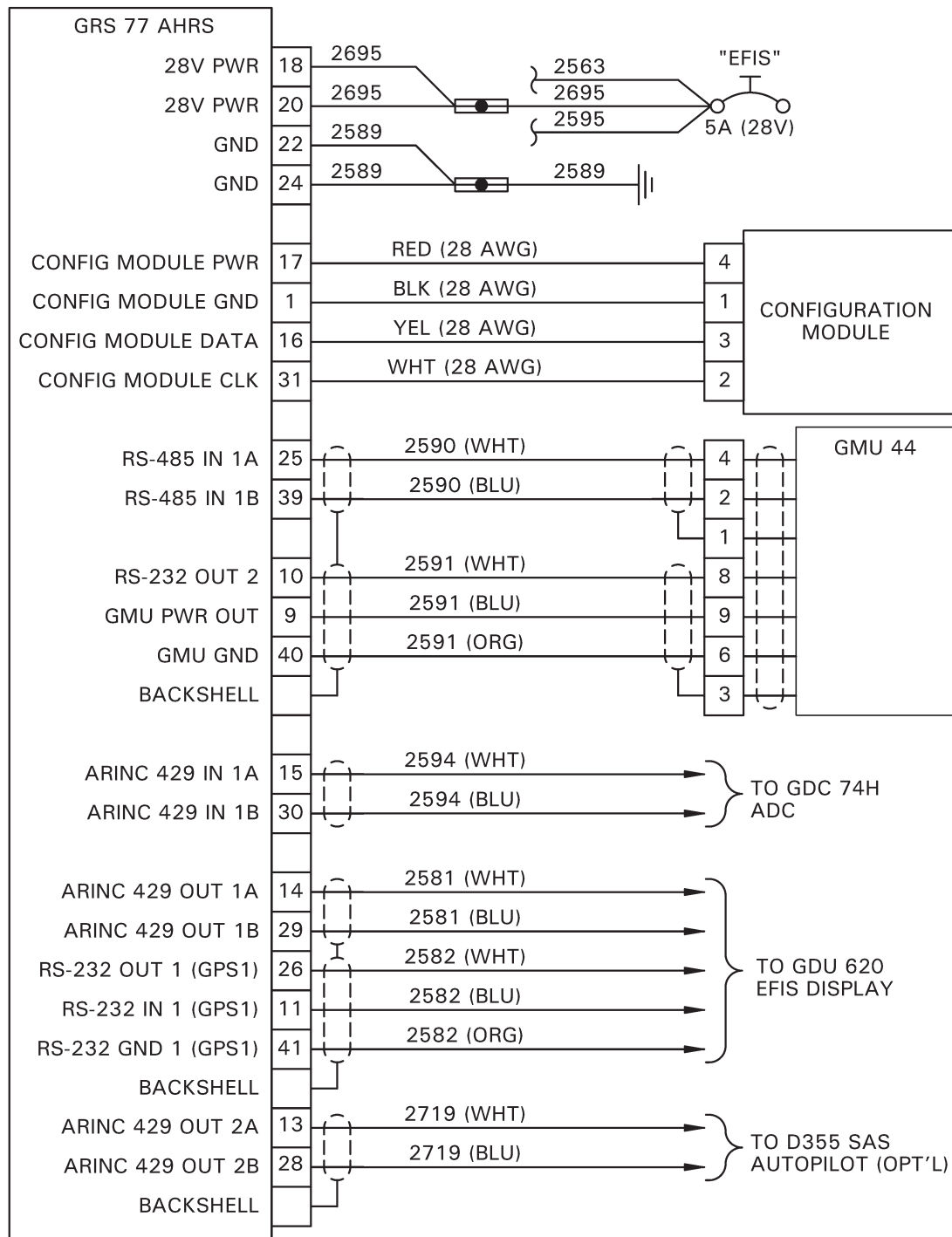

F817 REV E

FIGURE 14-34 F817-1 G500H LRU INSTALLATION – GRS 77 AHRS

Intentionally Blank

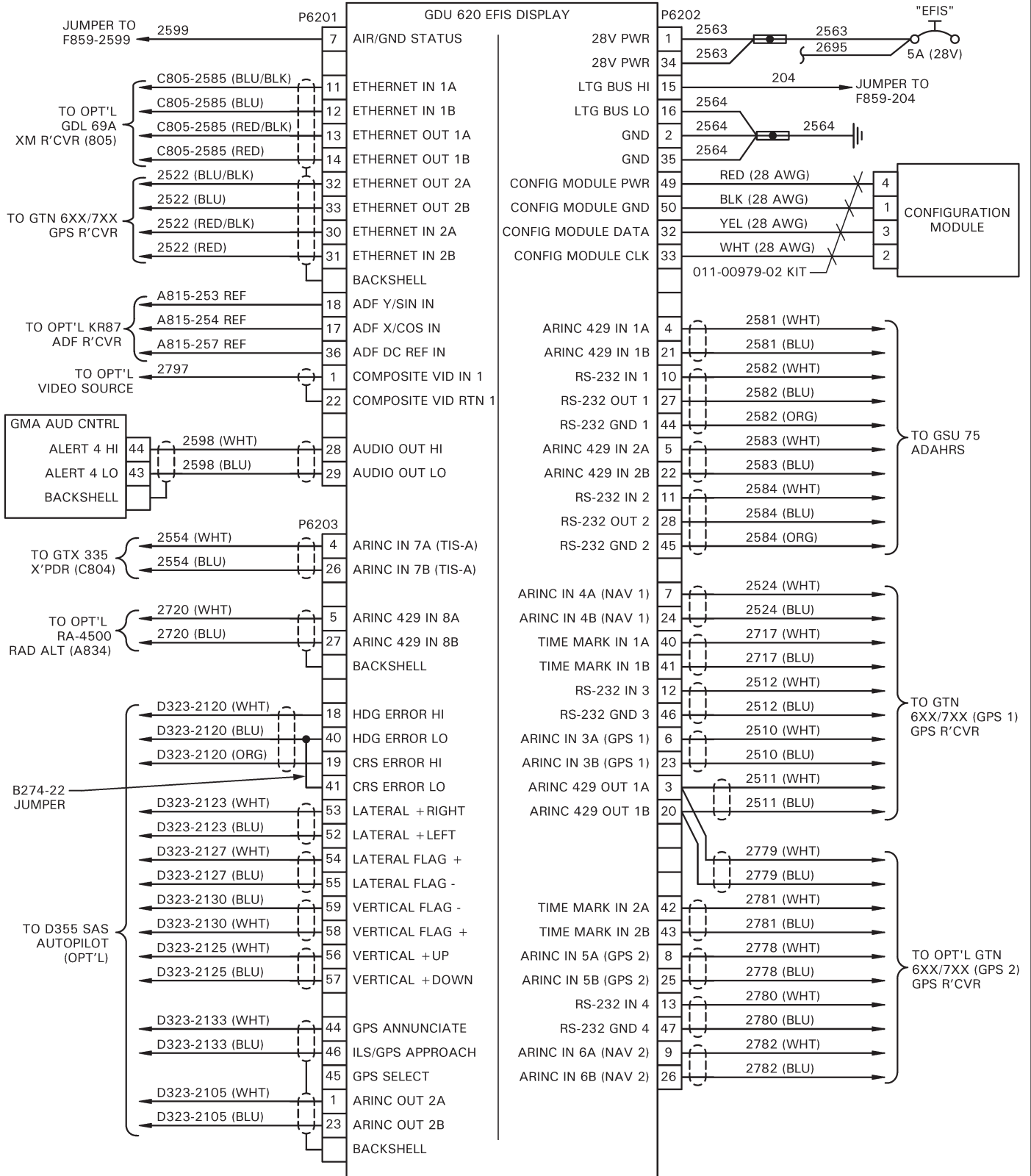

F817 REV J

FIGURE 14-35 F817-2, -4, AND -5 G500H LRU INSTALLATION – GDU 620

Intentionally Blank

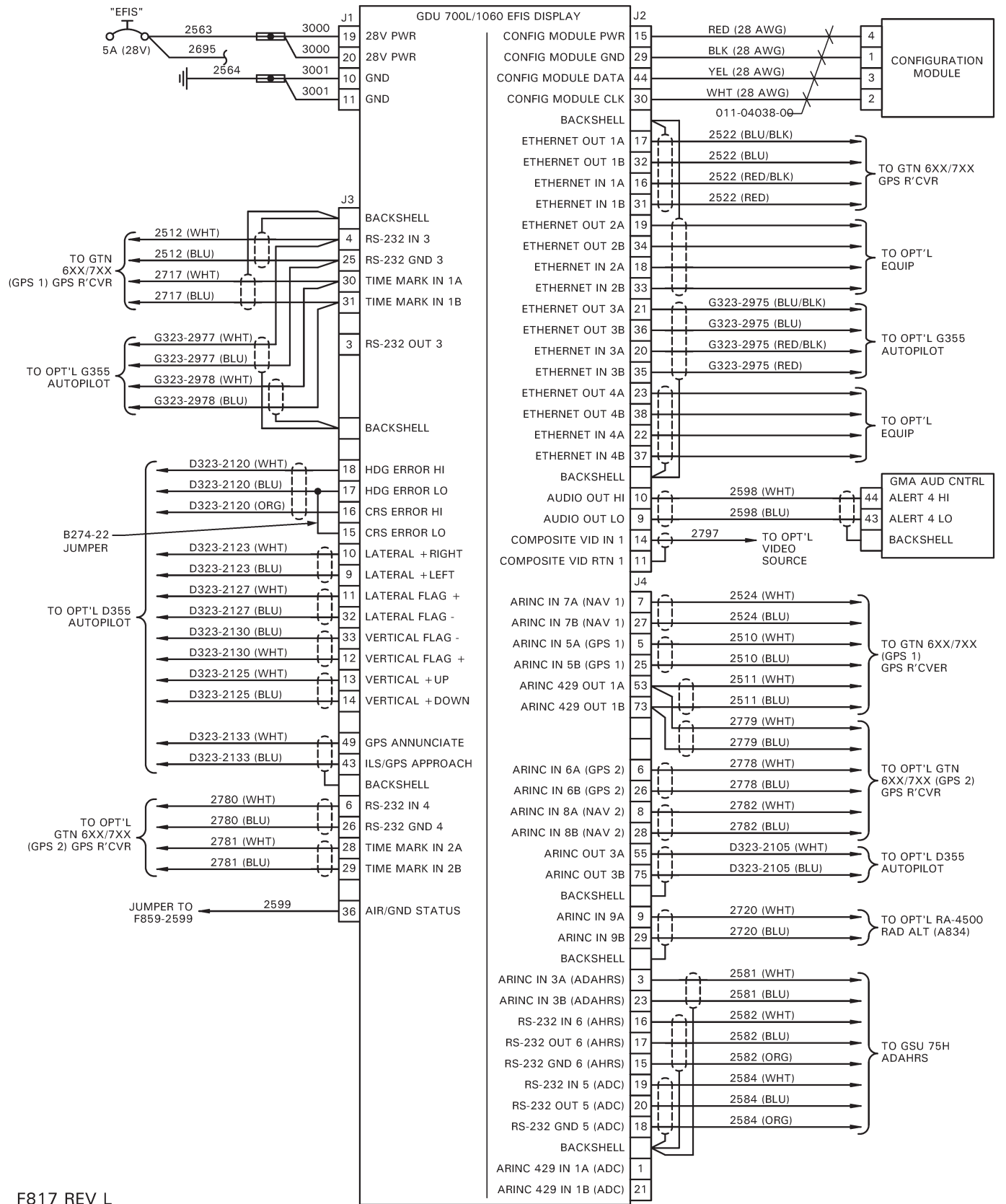

F817 REV L

FIGURE 14-36 F817-6 AND -7 G500H LRU INSTALLATION – GDU 700L/1060

Intentionally Blank

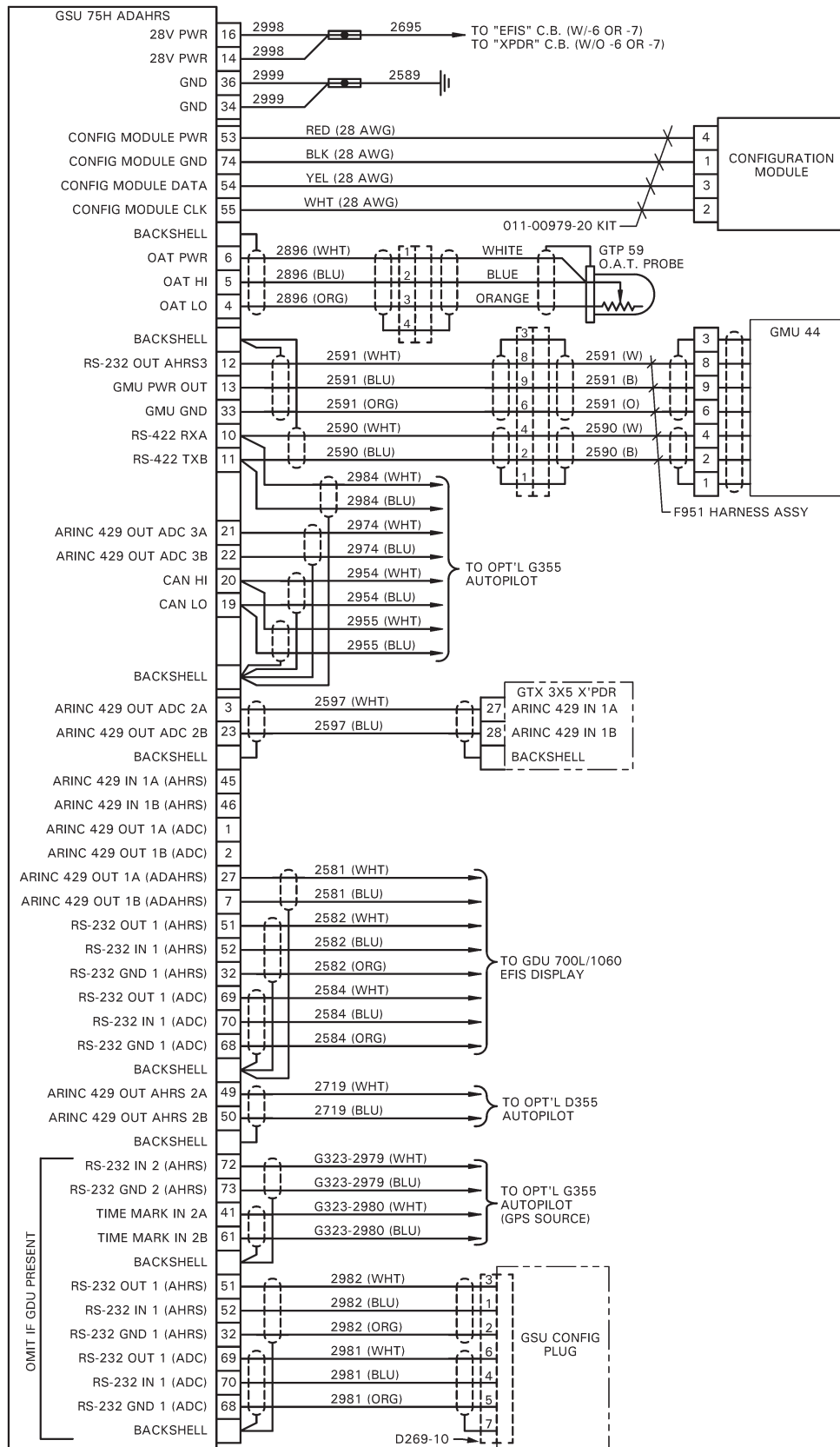

F817 REV L

FIGURE 14-37 F817-8 G500H LRU INSTALLATION – GSU 75 ADAHRS

Intentionally Blank

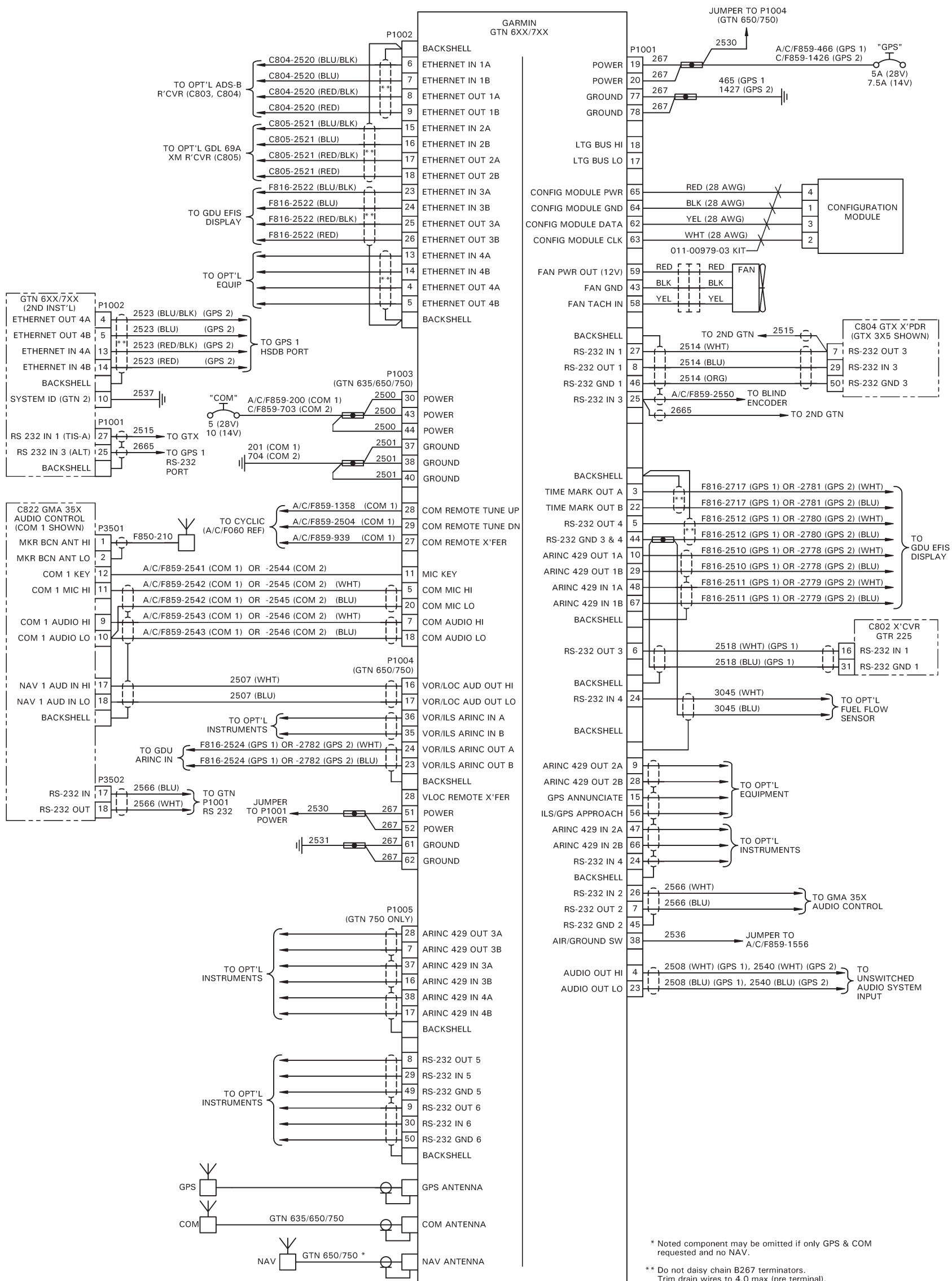
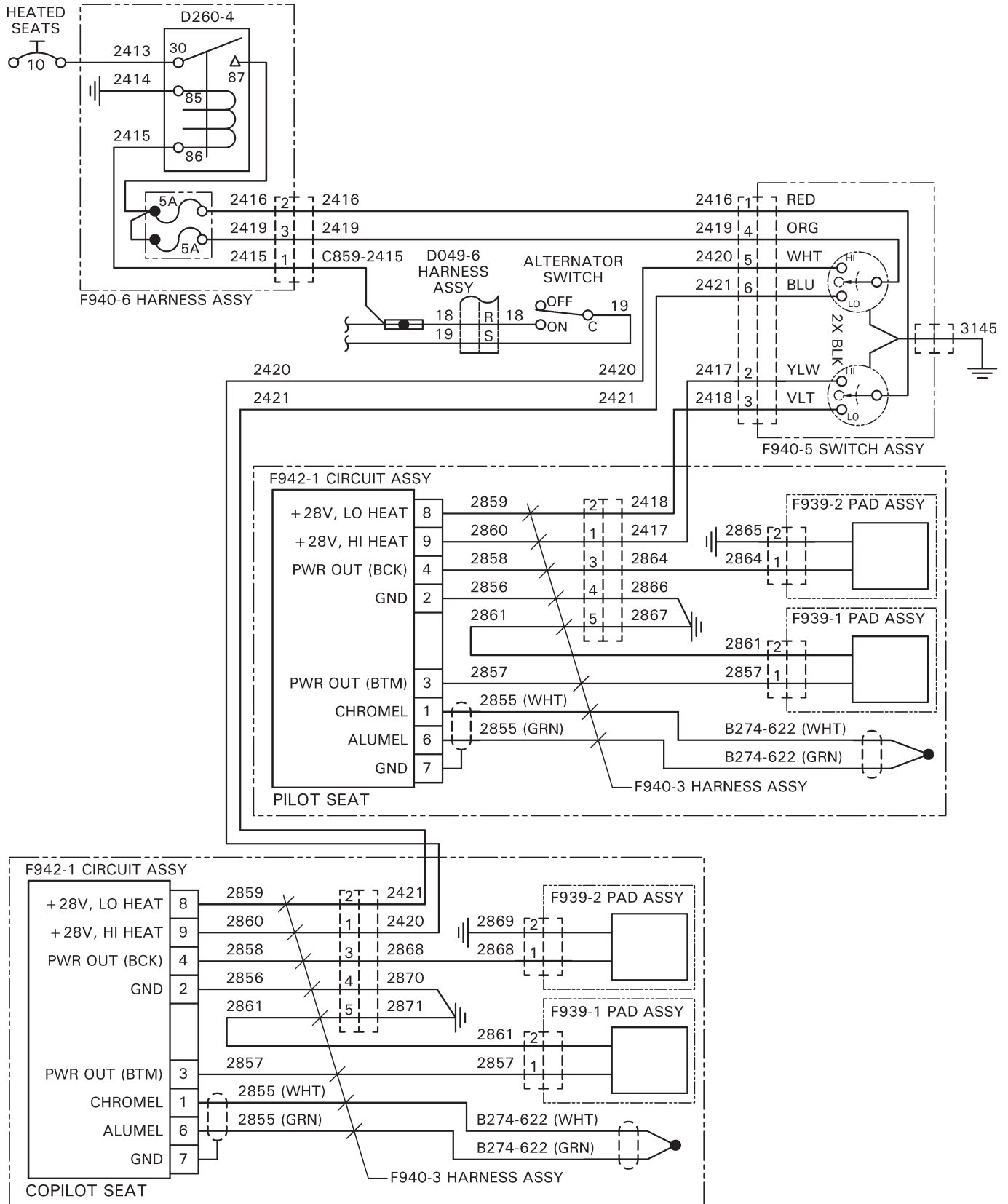

FIGURE 14-38 F818-1 THRU -11 GPS INSTALLATION (GTN 6XX/7XX, G500H CONSOLE)

F818 REV H

* Noted component may be omitted if only GPS & COM requested and no NAV.
 ** Do not daisy chain B267 terminators. Trim drain wires to 4.0 max (pre terminal).

Intentionally Blank



C938 REV A

FIGURE 14-39 HEATED SEATS

Intentionally Blank

CHAPTER 15**FURNISHINGS**

<u>Section</u>	<u>Title</u>	<u>Page</u>
15.000	Description	15.1
15.100	Seat Harnesses	15.3
15.110	Standard Seat Harnesses	15.3
15.120	Optional Five- and Four-Point Seat Harnesses	15.4
15.200	Seat Assemblies, Aft Seat Seat Back Assemblies, & Back Rest Assembly Replacement	15.5
15.210	Seat Assemblies	15.5
15.220	Aft Seat Seat Back Assemblies	15.5
15.230	Back Rest Assembly Replacement	15.6
15.240	Heated Seats	15.7
15.300	Carpet	15.9
15.310	Forward Cabin Floor Carpet	15.9
15.320	Adhered Carpet	15.9
15.400	Insulation and Headliner Replacement	15.11
15.500	General Maintenance	15.12
15.510	Pilot's Operating Handbook (POH) Strap Replacement	15.12
15.520	License Holder Replacement	15.12
15.530	Map Pocket Replacement	15.12
15.600	Emergency Equipment	15.13
15.610	Emergency Locator Transmitter (ELT)	15.13
15.620	Fire Extinguisher	15.14
15.700	Cyclic Guard	15.15

Intentionally Blank

CHAPTER 15

FURNISHINGS

15.000 Description

The seats are not adjustable but, on later aircraft, pilot-side pedals are adjustable. Each helicopter is supplied with a cushion which can be placed behind the pilot to position him farther forward. This allows shorter pilots to reach the pedals, the cyclic grip in its most forward position, and the controls on the center console.

Each seat is equipped with a combined lap belt and inertia reel shoulder strap. The inertia reel is normally free but will lock if there is sudden movement as would occur in an accident.

Four- or five-point harnesses are optional for the front seats. The lap belts on these harnesses should be adjusted to eliminate slack. On five-point harnesses, the lower strap should be adjusted as necessary to ensure that the buckle does not interfere with the cyclic grip in the full aft position. Later harnesses are equipped with a webbing stop located above the inertia reel. The stops limit shoulder strap retraction of the harnesses and should be adjusted so the straps are comfortable without excessive slack.

A baggage compartment is located under each seat. Seat cushions hinge forward for access. (R44 Cadet: Two additional compartments are located under the rear deck. The rear deck covers hinge forward and have lockable latches.)

Optional anchor loops located in the cabin ceiling above the door posts provide attachment points for a safety tether for equipment or occupants during doors-off operation.

Refer to § 15.700 for description of optional cyclic guard.

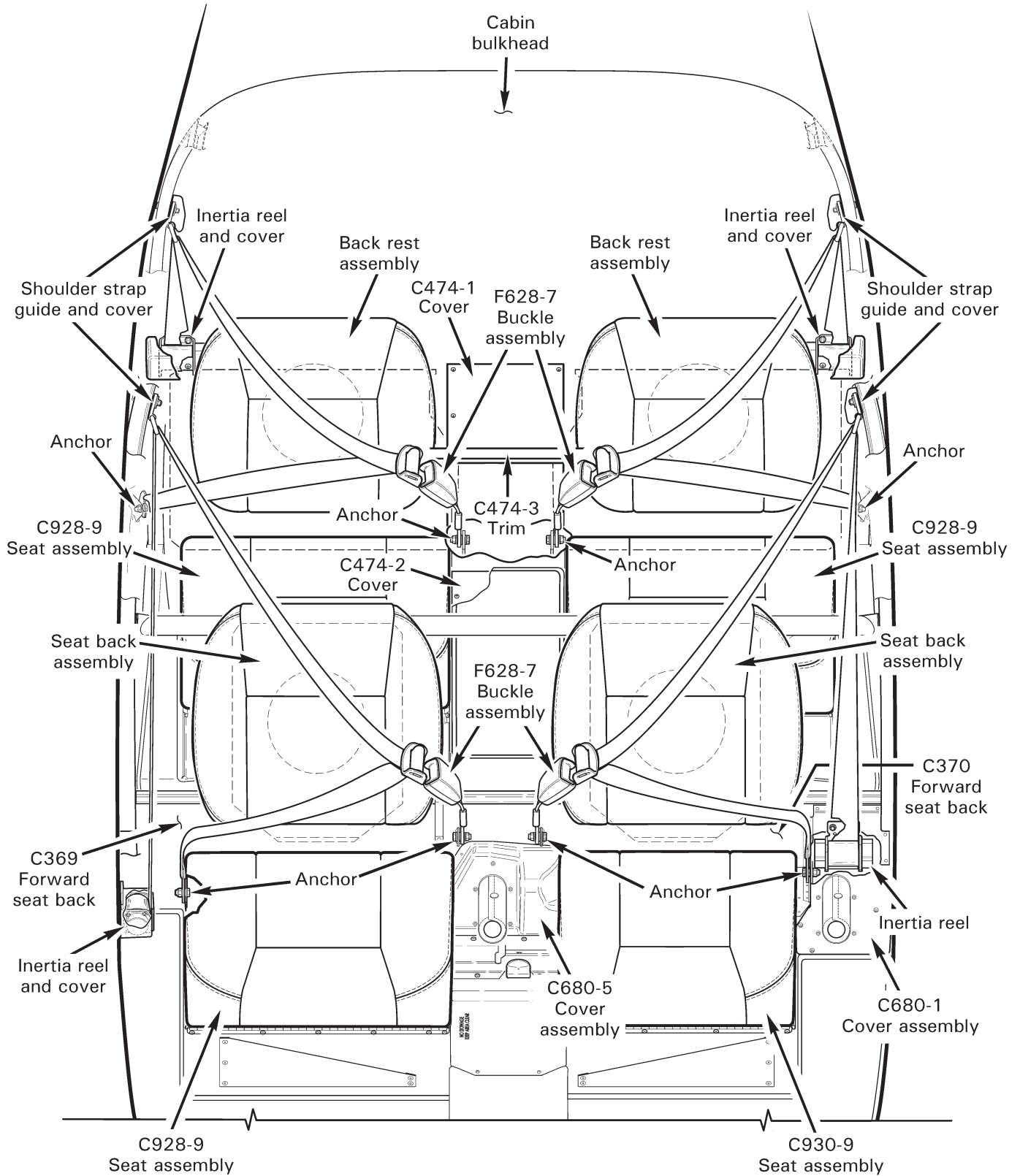

FIGURE 15-1 SEAT HARNESSES, SEAT ASSEMBLIES, AND BACK RESTS

15.100 Seat Harnesses

15.110 Standard Seat Harnesses

A. Removal

1. Refer to Figure 15-1. As required, remove C680-1 (removable collective) cover assembly. Hinge seat assembly forward.
2. Remove hardware securing F628-7 (or earlier C628-4) buckle assembly to inboard anchor. Remove hardware securing lap belt to outboard anchor.
3. Remove shoulder strap guide cover and remove hardware securing guide to door frame.
4. Remove inertia reel cover and remove hardware securing reel to cabin. Remove seat harness.

B. Installation

1. Refer to Figure 15-1. Install hardware securing inertia reel to cabin and install reel cover. Verify security.
2. Install hardware securing shoulder strap guide to door frame (forward seat harness: orient bolt head flats parallel to door post within 5°). Standard torque fastener per § 1.320. Install guide cover; verify security.
3. a. Rotate F628-7 buckle assembly 35°–40° forward; install hardware securing buckle assembly to inboard anchor. Standard torque fastener per § 1.320.
b. Install hardware securing C628-4 buckle assembly to inboard anchor. Standard torque fastener per § 1.320. Using a calibrated spring scale pulling on buckle slot, measure force required to rotate buckle assembly about its fastener. Force required to rotate buckle is 1.5–2.5 lb. If force is less than 1.5 lb., replace A041-6 spring washer or increase spring washer height by slightly bending and repeat step.

CAUTION

Verify no sharp edges or burrs on buckle assembly locking bar or latch plate.

4. Ensure belt is not twisted; install hardware securing lap belt to outboard anchor. Standard torque fastener per § 1.320.
5. If removed, install C680-1 (removable collective) cover assembly. Hinge seat assembly aft.

15.120 Optional Five- and Four-Point Seat Harnesses

A. Removal

1. As required, remove C680-1 (removable collective) cover assembly. Hinge seat assembly forward.
2. Remove hardware securing five- or four-point harness assembly lap belts to inboard and outboard anchors. Remove hardware securing fifth-point belt to seat box, as required.
3. Remove hole plugs secured to forward side of back rest panel.
4. Remove inertia reel cover and remove hardware securing reel to cabin. Pull connector and buckle assembly through support tube padding cover strap and remove harness.

B. Installation

1. Install hardware securing five- or four-point harness assembly inertia reel to cabin and install reel cover. Install hole plugs in forward side of back rest panel. Verify security.
2. Pull connector and buckle assembly through support tube padding cover strap.
3. Ensure belt is not twisted; install hardware securing lap belts to inboard and outboard anchors. Standard torque fasteners per § 1.320. Verify security.
4. If removed, install C680-1 (removable collective) cover assembly. Hinge seat assemblies aft.

15.200 Seat Assemblies, Aft Seat Seat Back Assemblies, & Back Rest Assembly Replacement**15.210 Seat Assemblies****A. Removal**

1. Forward Seats: If heated seats are installed, turn battery switch off and pull SEAT HEATERS circuit breaker (10 amp) on circuit breaker panel. Disconnect F940-3 wire harness from F941-1 module assembly wiring at connector.
2. Refer to Figure 15-1. Remove hardware securing seat assembly hinge to seat box and remove seat assembly.

B. Installation

1. Forward Seats: If heated seats are installed, turn battery switch off and pull SEAT HEATERS circuit breaker (10 amp) on circuit breaker panel.
2. Refer to Figure 15-1. Position seat assembly on seat box and install hardware securing hinge to seat box. Verify security.
3. Forward Seats: If heated seats are installed, connect F940-3 wire harness to F941-1 module assembly wiring at connector. Verify security. Push in circuit breaker on circuit breaker panel and turn battery switch on. Verify proper function of switches at control panel. Verify temperature setting system functionality by toggling between high/low/off heat positions.

15.220 Aft Seat Seat Back Assemblies**A. Removal**

1. Refer to Figure 15-1. Remove hardware securing C474-1 cover, C474-3 trim, and C474-2 cover to cabin. Remove covers and trim.
2. Remove hardware securing seat back assembly to cabin bulkhead. Remove seat back assembly.

B. Installation

1. Install seat back assembly and install hardware securing seat back assembly to cabin bulkhead. Verify security.
2. Install C474-1 cover, C474-3 trim, and C474-2 cover, and install hardware securing covers and trim to cabin. Verify security.

15.230 Back Rest Assembly Replacement

A. Forward Back Rest Assembly

1. If heated seats are installed, turn battery switch off and pull SEAT HEATERS circuit breaker (10 amp) on circuit breaker panel. Disconnect F940-3 wire harness from F939-2 pad assembly wiring at connector.
2. Refer to Figure 15-1. Drill out rivets securing back rest assembly cushion to back rest panel and remove cushion. Deburr holes.
3. Remove old adhesive residue from back rest support tube with plastic wedge. Wipe surface with a clean cloth, wet with acetone.
4. Center and straighten new cushion on back rest panel. Match drill cushion through back rest panel #30 holes and deburr holes. Clean up debris.
5. Attach cushion to back rest panel with rivets. Verify security.
6. Apply B270-18 adhesive to underside of cushion flap and to mating portion of support tube. Pull flap around tube, smooth wrinkles, and trim excess flap. Remove excess adhesive prior to curing.
7. If heated seats are installed, push in circuit breaker on circuit breaker panel and turn battery switch on. Verify proper function of switches at control panel. Verify temperature setting system functionality by toggling between high/low/off heat positions.

B. Aft Back Rest Assembly

1. Remove aft seat seat back assembly per § 15.220 Part A.
2. Drill out rivets securing back rest assembly cushion to seat back panel and remove cushion. Deburr holes.
3. Center and straighten new cushion on seat back panel. Match drill cushion thru seat back panel #30 holes and deburr holes. Clean up debris.
4. Attach cushion to seat back panel with rivets. Verify security.
5. Install back rest assembly per § 15.220 Part B.

15.240 Heated Seats

A. Description

Heated seat bottoms and backrests for the forward seats are an option. Switches to control low and high heat settings for both heated seats are located on the panel above the right-side collective boot.

The seat heaters operate only when the alternator switch is in the ON position to reduce the likelihood of inadvertently draining the battery before the engine is started.

B. Schematics

Refer to Figure 14-39 for heated seats installation electrical schematic.

C. Removal and Installation

Seat Assemblies

Remove and install seat assemblies per § 15.210.

(Circuit Board) Module Assembly Replacement

1. Remove seat assembly per § 15.210 Part A.
2. Disconnect F940-3 harness from F941-1 module assembly at connector.
3. Drill out rivets securing module to seat assembly pan and remove module. Clean up debris.
4. Cleco (sheet metal fastener) new module to seat assembly pan. Progressively remove clecos and install rivets securing module to pan. Verify security.
5. Connect F940-3 harness to module at connector. Verify security.
6. Install seat assembly per § 15.210 Part B.

D. Every 100-Hour / Annual Inspection or Troubleshooting

1. Open circuit breaker panel and applicable access panels.
2. Verify correct fuses are installed in circuits: F940-6 harness assembly requires (2) AGC-5 fuses, one for each heated seat.
3. Inspect condition of and verify no obvious damage to F941-1 module assemblies, F940-5 switch assembly, wire harnesses, copper bus bars, circuit breaker, or circuit breaker wiring. Verify no loose, chafed, or broken wires or terminals. Verify no evidence of arcing. Verify installed equipment security.
4. Secure circuit breaker panel and removed access panels.
5. Verify proper function of switches at control panel. Verify temperature setting system functionality by toggling between high/low/off heat positions.

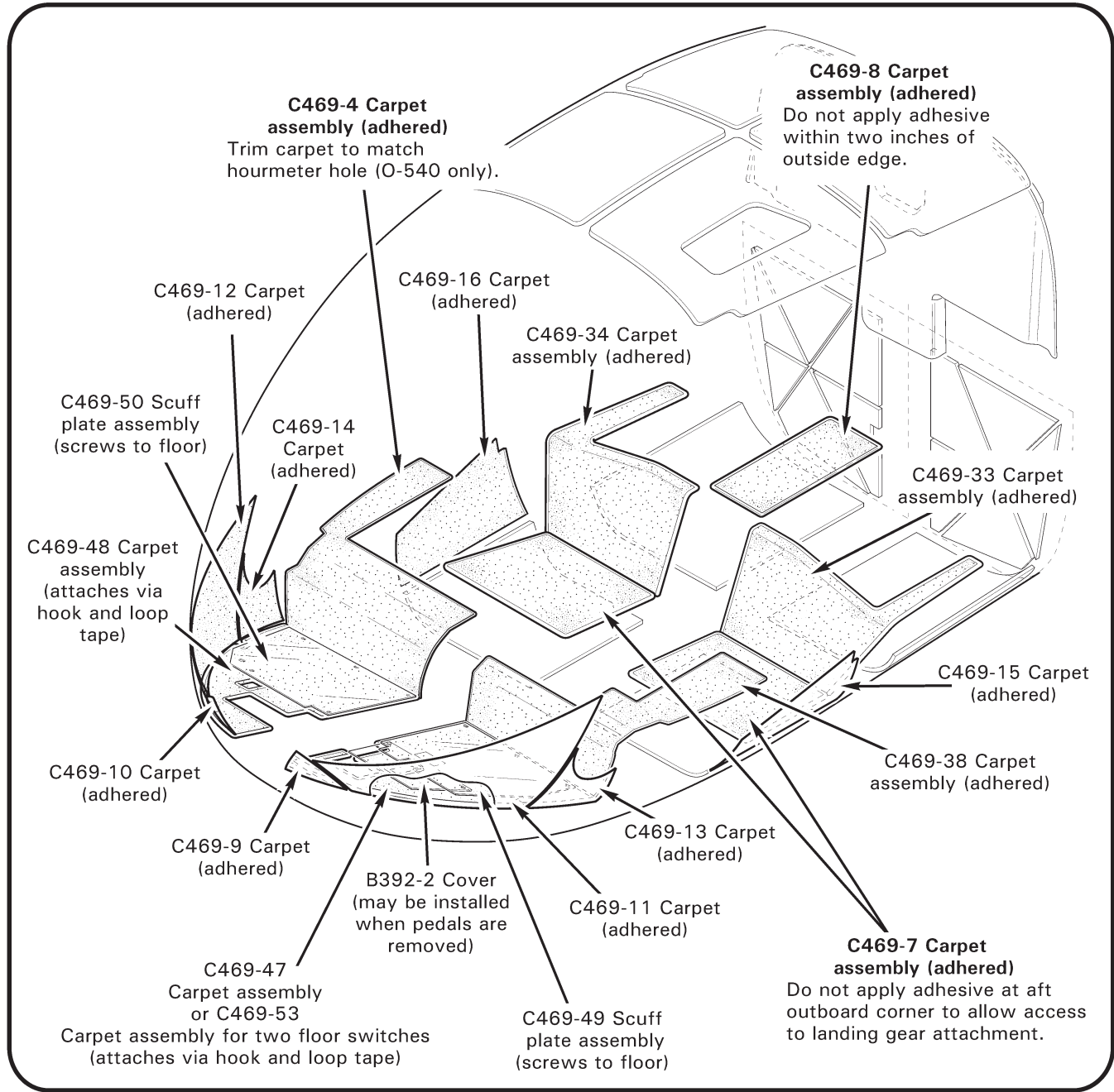

FIGURE 15-2 CARPET

15.300 Carpet15.310 Forward Cabin Floor Carpet**A. Removal and Installation**

1. Refer to Figure 15-2 (observe notes for specific parts). Remove adjustable and/or removable pedals, as required. If installed, remove hardware securing B392-2 cover to cabin floor and remove cover.
2. Remove hardware securing scuff plates to floor and remove scuff plates. Detach carpet assembly from floor via hook and loop tape (Velcro).
3. Install carpet assembly, and attach carpet to floor via hook and loop tape.
4. Install scuff plates, and install hardware securing scuff plates to floor.
5. Install adjustable and/or removable pedals, as required. As required, install B392-2 cover, and install hardware securing cover to floor.

15.320 Adhered Carpet**A. Removal and Installation****WARNING**

Ensure adequate ventilation when using solvents and adhesives.

CAUTION

Use caution when removing adhered carpet if carpet is intended for reuse.

NOTE

Refer to Chapter 94 Cadet Version, as required.

1. Refer to Figure 15-2 (observe notes for specific parts). Starting at corners, gently peel back carpet by hand, or with a plastic wedge or putty knife. Dampen old adhesive with Dupont Prep-Sol (or equivalent) to facilitate removal.
2. Verify proper carpet fit and trim as required (do not trim carpet welt). Apply B270-8 adhesive to bonding surface and carpet backing. Press carpet to surface, smooth wrinkles, and remove excess adhesive prior to curing.

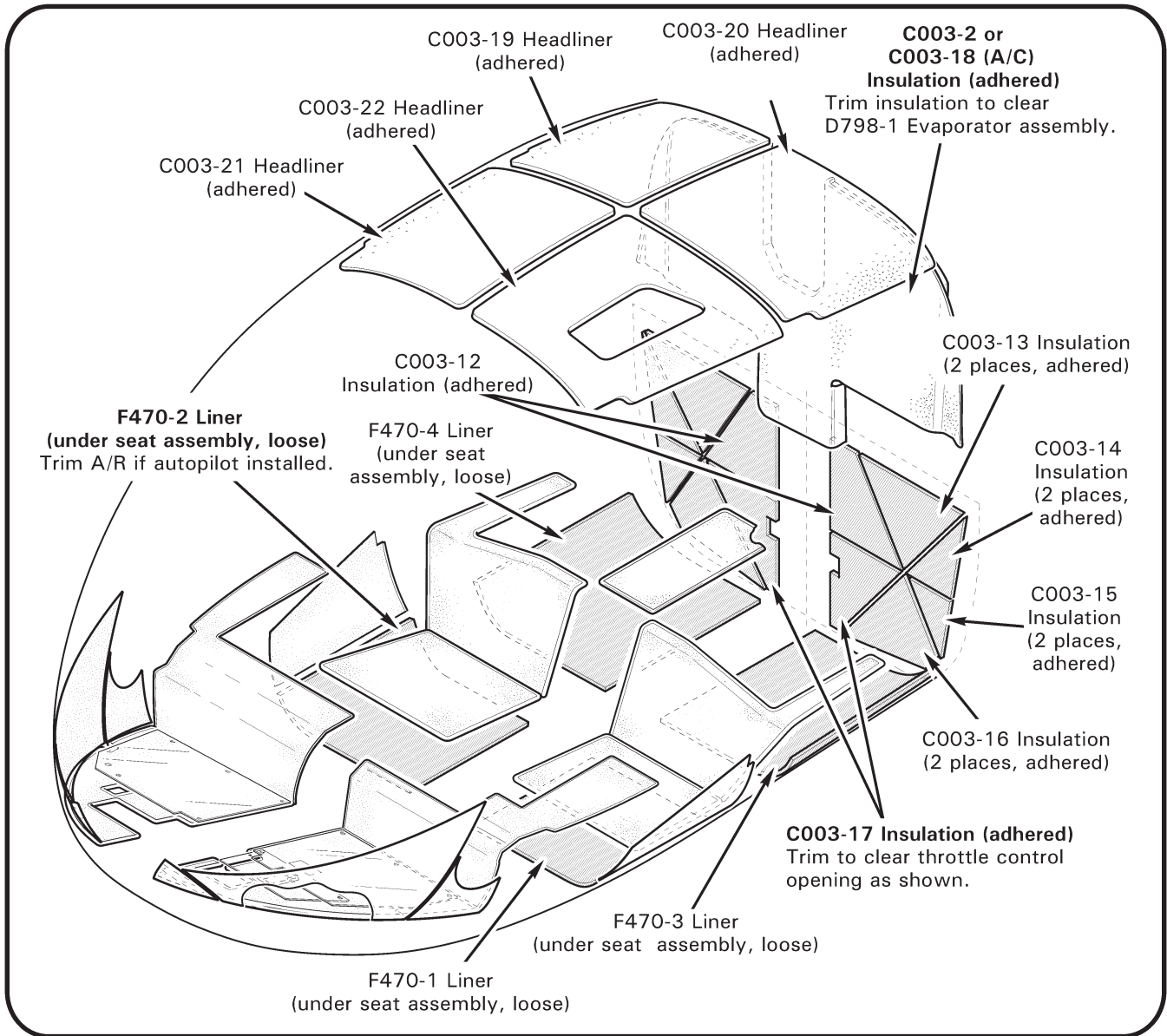

FIGURE 15-3 INSULATION AND HEADLINER

15.400 Insulation and Headliner Replacement**WARNING**

Ensure adequate ventilation when using solvents and adhesives.

NOTE

Use caution not to damage surface underneath insulation when removing insulation with tools. Insulation is installed with adhesive, except under seat assemblies. Order new insulation as required; reuse of removed insulation is not recommended.

NOTE

Refer to Chapter 94 Cadet Version, as required.

1. Refer to Figure 15-3 (observe notes for specific parts). Peel off insulation by hand. Using a plastic wedge or putty knife, carefully remove residual insulation and old adhesive. Wipe surface with a clean cloth, wet with acetone.
2. Verify proper insulation fit and trim as required. Apply B270-8 adhesive to bonding surface and insulation backing. Press insulation to surface, smooth wrinkles, and remove excess adhesive prior to curing.

15.500 General Maintenance**15.510 Pilot's Operating Handbook (POH) Strap Replacement****A. Removal**

Remove Pilot's Operating Handbook (POH). Drill out rivets securing POH retaining strap to cabin and remove strap. Deburr holes and clean up debris.

B. Installation

Cleco retaining strap to cabin. Progressively remove clecos and install rivets; verify security. Install POH.

15.520 License Holder Replacement**A. Removal**

Remove aircraft documents from license holder. Drill out rivets securing license holder to cabin and remove license holder. Deburr holes and clean up debris.

B. Installation

Cleco license holder to cabin. Progressively remove clecos and install rivets; verify security. Insert aircraft documents into license holder and tuck holder under windshield frame.

15.530 Map Pocket Replacement**A. Removal**

Remove contents. Drill out rivets securing map pocket to seat support. Remove pocket, washers, and retaining strips. Deburr holes and clean up debris.

B. Installation

1. Fold (long) outboard pocket edge around (long) A913-1 strip, align holes, and align holes with front of forward seat box. Cleco in place.
2. Pull material taut, fold (short) inboard pocket edge around (short) A913-2 strip, align holes, and align holes with front of forward seat box. Cleco in place. Trim excess material.
3. Progressively remove clecos and install washers and rivets.

15.600 Emergency Equipment

15.610 Emergency Locator Transmitter (ELT)

A. Description

The ELT activates when subjected to a significant change in velocity (as in a crash), by remote control switch located on the cyclic control panel, or by a switch on the ELT transmitter. Refer to § 37-90 for system description.

Refer to Kannad Aviation AF Integra / AF-H Integra or 406 AF-Compact/406 AF-Compact (ER) ELT Installation and Operation Manual for maintenance requirements and procedures. Refer to § 1.101 for scheduled maintenance.

Register an ELT when first purchased, when contact information changes, or when aircraft ownership, or tail number changes. Registration information is available online at: www.cospas-sarsat.org.

Dongles contain a memory chip that must be programmed with aircraft-specific information prior to installation for the ELT to function. The dongle may be removed and shipped to RHC or a Kannad Service Center for reprogramming. Kannad Aviation's Programming Data Sheet is available online at: www.robinsonheli.com.

B. Transmitter

Removal

1. Release D693-4 strap assembly or B359-2 (reusable) ty-rap.
2. Release Velcro strap; disconnect dongle and antenna wiring from transmitter at connectors and remove transmitter.

Installation

1. Connect dongle and antenna wiring to transmitter at connectors. Verify security.
2. Position transmitter on mounting bracket and secure with Velcro strap. Secure D693-4 strap assembly or install B359-2 (reusable) ty-rap around transmitter and bracket. Verify security.

C. Dongle

Removal

Cut and discard ty-raps as required, disconnect dongle from transmitter and airframe harness at connectors, and remove dongle.

Installation

1. Connect programmed dongle to transmitter and airframe harness at connectors.
2. Install ty-raps as required. Cinch ty-raps until snug without over-tightening, and trim tips flush with heads. Verify security.

15.620 Fire Extinguisher**CAUTION**

Extinguisher is rated for a max storage and operating temperature of 120°F (49°C). If operating conditions would expose extinguisher to higher temperatures (e.g. long term parking in the sun in a hot climate), remove extinguisher and store it in a cooler area between flights.

A. Inspection

Every month: Visually inspect fire extinguisher and perform weight check (a scale with 1 gram precision or better is required). Remove extinguisher from service if total weight falls below 500 grams. If desired, order one G654-15 decal (blank maintenance log) and attach to extinguisher, to record weight checks.

Every 12 years: Remove fire extinguisher from service. Year of manufacture is labeled on bottom of extinguisher; remove extinguisher from service at end of 12th year from labeled date.

B. Bracket Removal

1. Unlatch fire extinguisher bracket and remove extinguisher.
2. Remove hardware securing bracket to chin and remove bracket.

C. Bracket Installation

1. Install hardware securing fire extinguisher bracket to chin. Select screw length as required to provide 0.00–0.06 inch thread exposure. Verify security.
2. Install fire extinguisher and latch bracket.

D. Strap and Pocket Assembly Replacement

1. Detach strap assembly from pocket assembly, and detach pocket assembly straps via hook and loop tape. Remove fire extinguisher.
2. As required, open upper console. If installed, remove hardware securing HID landing light left ballast to left console and secure ballast away from workspace.
3. Drill out rivets securing strap assembly and pocket assembly to cabin or console and remove strap and pocket. Deburr holes and clean up debris.
4. Cleco new strap assembly and pocket assembly to cabin or console. Progressively remove clecos and install washers and rivets. Verify security.
5. If removed, install hardware securing HID landing light left ballast to left console. Verify security. If opened, close upper console.
6. Install fire extinguisher and attach pocket assembly straps around extinguisher via hook and loop tape. Route strap assembly through extinguisher head and attach to pocket assembly via hook and loop tape. Verify security.

15.700 Cyclic Guard**NOTE**

Flight with handle assembly & mounting hardware removed or with handle in either position is permissible.

A. Description

The optional cyclic guard is a bar that extends from the inboard corner of the left front seat to the instrument console. It is intended to act as a barrier to help prevent inadvertent interference with the cyclic control. The guard also provides a hand grip for a passenger's right hand.

In order to access the under seat compartment with the guard installed, pull the silver spring knob at the forward end of the guard and allow the aft end to rotate down away from the seat hinge. To re-secure the guard, lift the aft end and allow the spring knob to lock back in place.

It is recommended that the guard be installed whenever a non-pilot passenger occupies the left front seat. A pilot flying from the left seat may find that the guard contacts the right leg when feet are on the pedals. The guard should be removed prior to flight if the pilot finds it objectionable.

B. Removal

1. With G721-1 handle assembly in locked (upper, extended) position, remove hardware securing handle to left hand forward seat.
2. Pull spring knob at forward end of handle assembly and slide handle off of G722-6 plate.
3. As required, open console assembly. Remove hardware securing plate to lower console and remove plate.

C. Installation

1. If G722-6 plate was removed, open console assembly. Position plate on lower console and install hardware; verify security. Close and secure console.
2. Pull spring knob at forward end of G721-1 handle assembly and slide handle onto plate until pin is in locked (upper, extended) position. Install hardware securing handle to left hand forward seat; verify security.
3. Actuate handle assembly and verify proper operation.

D. Scheduled Inspections

Refer to § 2.400 100-Hour/Annual Inspection.

Intentionally Blank

CHAPTER 16**DIMENSIONS AND DESCRIPTIONS**

<i>Section</i>	<i>Title</i>	<i>Page</i>
16-10	Version Description	16.1
16-20	Datum	16.2
16-30	Method of Measurement	16.2
16-40	External Dimensions	16.3
16-50	Station Locations	16.7
16-60	Access and Inspection Panels	16.7
16-61	B526 Screws and B527-08 Washers	16.7
16-70	Antenna Locations	16.8

Intentionally Blank

CHAPTER 16

DIMENSIONS AND DESCRIPTIONS

16-10 Version Description

Type Certificate Data Sheet (TCDS) H111NM is available at FAA Dynamic Regulatory System website: <https://drs.faa.gov>.

WARNING

Refer to R44 Illustrated Parts Catalog (IPC) for specific part number differences between versions.

- R44, "Astro": 4-digit serial numbers 0002, 0004 thru 0760. Lycoming O-540-F1B5 carbureted engine derated to 205 horsepower maximum continuous power with 225 horsepower 5-minute takeoff rating. Required hydraulic cyclic & collective controls replace manual controls in year 2020. Gross weight 2400 pounds. 14-volt electrical system standard; 28-volt optional.
- R44 "Clipper": Fixed or pop-out float landing gear. Additional corrosion protection. Auxiliary horizontal stabilizer installed at base of lower vertical stabilizer. Drain valves installed in chin. Additional navigation lights atop mast fairing on fixed float versions. Marine radio package optional. Optional hydraulic cyclic & collective controls replace manual controls.
- R44, "Raven",
"Raven I",
"Clipper I": Hydraulic cyclic & collective controls standard. Adjustable pilot-side pedals. Serial number 0761 and subsequent. 28-volt electrical system became standard at S/N 2421.
- R44 II, "Raven II": 5-digit serial numbers 10001 and subsequent. Lycoming IO-540-AE1A5 fuel-injected engine derated to 205 horsepower maximum continuous power with 245 horsepower 5-minute takeoff rating. Gross weight 2500 pounds. 28-volt electrical system. Solid-state start booster for retard magneto. Second engine-oil cooler.
- R44 II, "Clipper II": Based on "Raven II." Fixed or pop-out float landing gear.
- Instrument Trainer: R44 or R44 II configuration with 10-hole instrument panel. VMC operations only.
- E.N.G. (Electronic News Gathering): R44 or R44 II configuration. 28-volt electrical system. Nose-mounted gyro-stabilized camera with tailcone-mounted battery. Standard microwave capability.

16-10 Version Description (continued)

Police: R44 or R44 II configuration. 28-volt electrical system. Includes searchlight, police radio package, and nose-mounted gyro-stabilized infrared-capable camera with tailcone-mounted battery. Optional microwave capability.

R44, "Cadet": 5-digit serial numbers 30001 thru 39999. Based on "Raven I". Lycoming O-540-F1B5 carbureted engine derated to 185 horsepower maximum continuous power with 210 horsepower 5-minute takeoff rating. Gross weight 2200 pounds. 28-volt electrical system standard. Two-place helicopter; aft seats removed. Fatigue life-limited part service lives extended to 2400/4800 hours (refer to § 3.300). Air conditioning optional.

16-20 Datum

The datum is located 100 inches forward of main rotor centerline.

16-30 Method of Measurement

Fuselage station, tailcone station, water line station, and butt line station values are measured in inches, rounded to the nearest hundredth.

16-40 External Dimensions

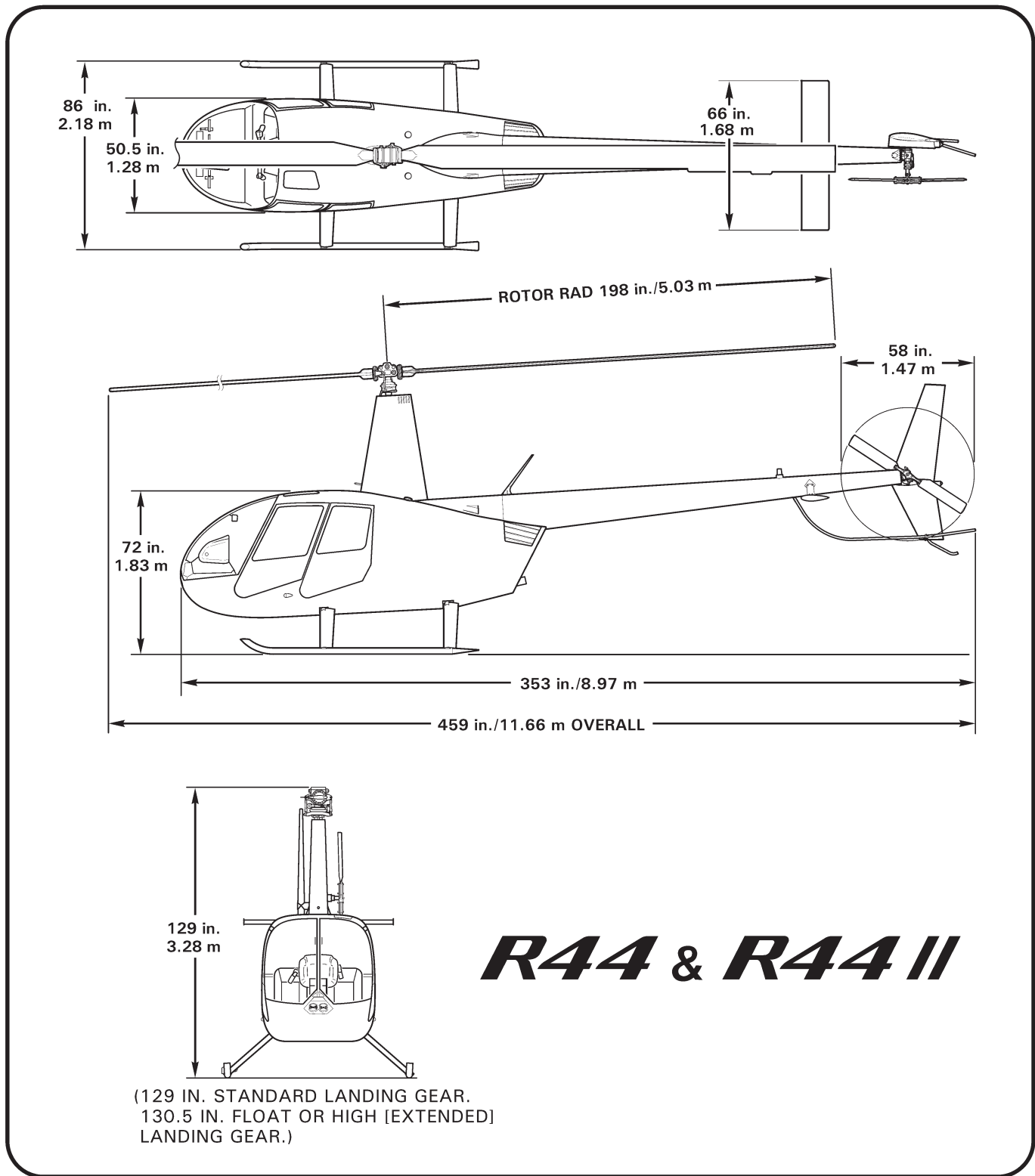

FIGURE 16-1 EXTERNAL DIMENSIONS
(F004-2 empennage installed)

16-40 External Dimensions (continued)

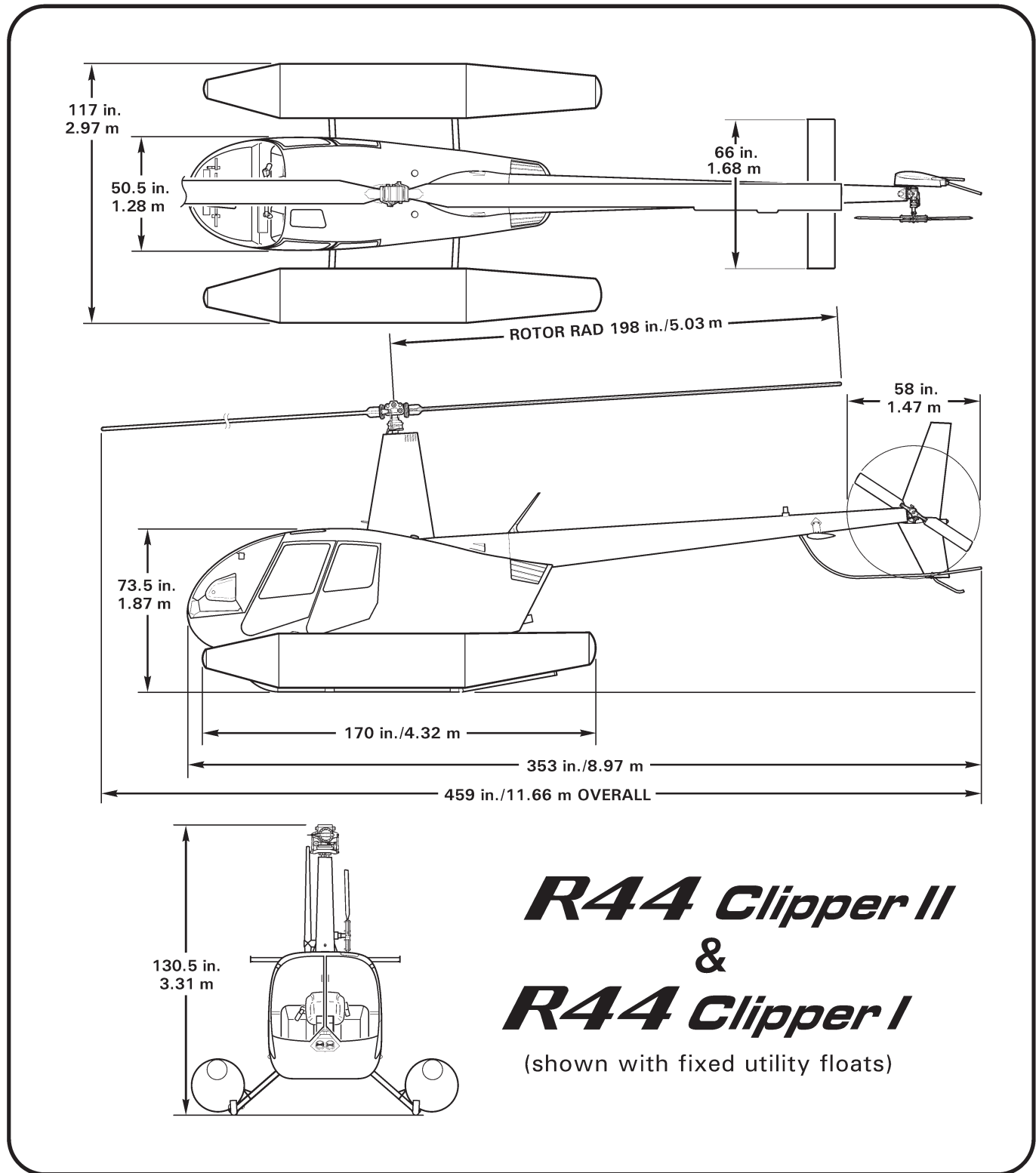

FIGURE 16-2 EXTERNAL DIMENSIONS
(F004-2 empennage installed)

16-40 External Dimensions (continued)

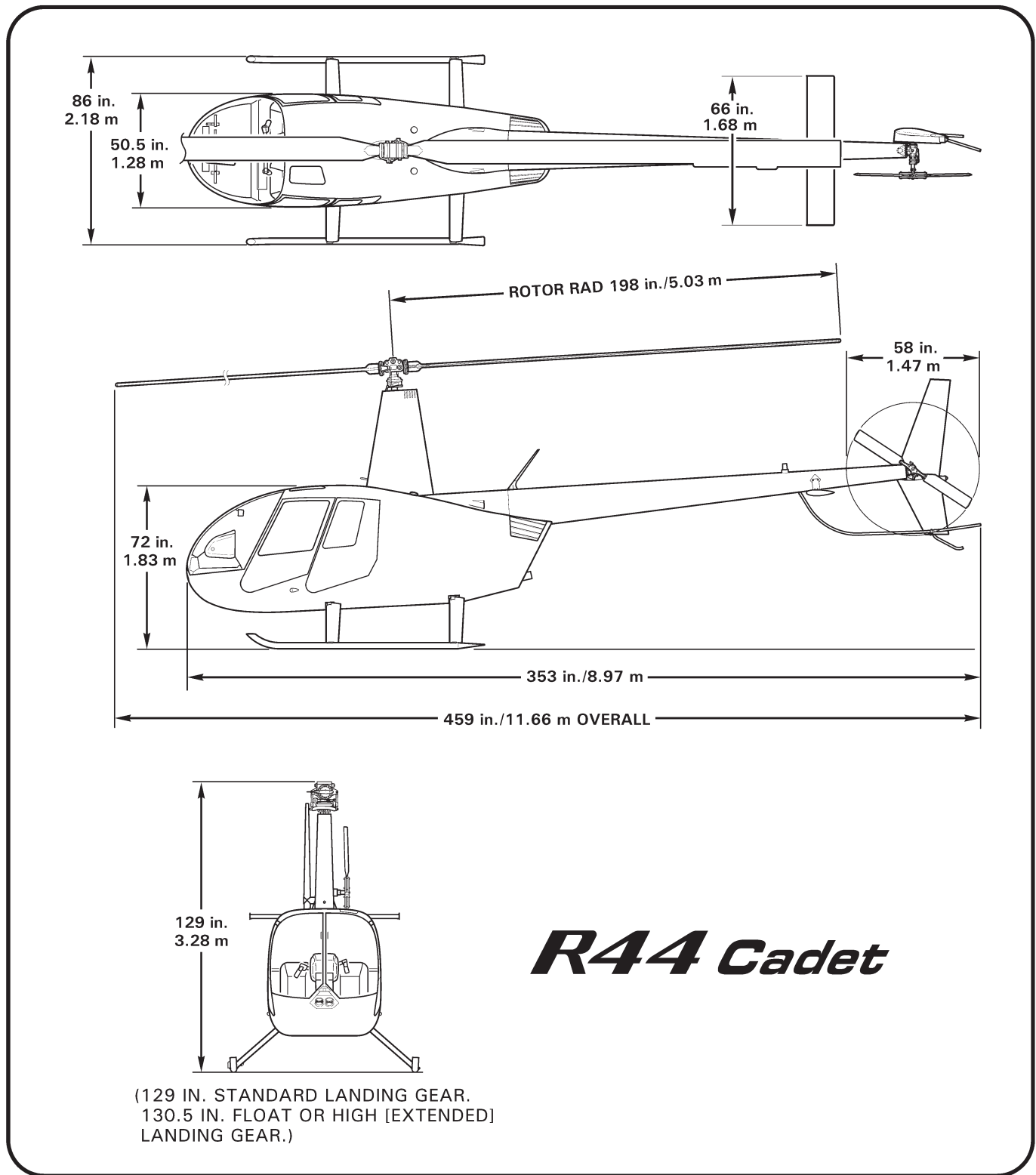

FIGURE 16-3 EXTERNAL DIMENSIONS
 (F004-2 empennage installed)

16-40 External Dimensions (continued)

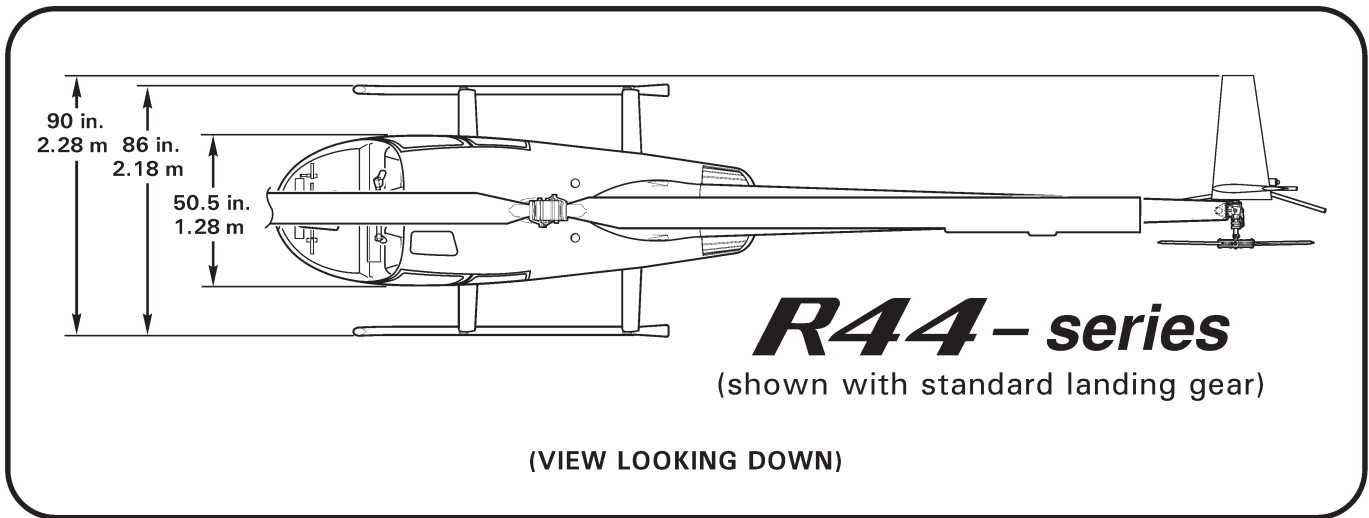

FIGURE 16-4 EXTERNAL DIMENSIONS
(C004-2 empennage installed)

16-50 Station Locations

Reserved.

16-60 Access and Inspection Panels

Refer to R44 Illustrated Parts Catalog Chapter 6 for access and inspection panel locations.

16-61 B526 Screws and B527-08 Washers

B526 (TORX Plus®) truss head screws may be used to secure cowlings and access panels. A B527-08 nylon washer may be used under a B526 screw head to further protect thin or painted surfaces.

Following B526 screws are interchangeable with MS27039C080_ screws used to secure cowlings and access panels:

<u>PART:</u>	<u>INTERCHANGEABLE WITH:</u>
MS27039C0806 screw	B526-6 screw
MS27039C0807 screw	B526-8 screw
MS27039C0808 screw	B526-8 screw

Following B526 screws are interchangeable with AN525-832R_ & AN526C832R_ screws:

<u>PART:</u>	<u>INTERCHANGEABLE WITH:</u>
AN525-832R6 or AN526C832R6 screw	B526-6 screw
AN525-832R7 or AN526C832R7 screw	B526-8 screw
AN525-832R8 or AN526C832R8 screw	B526-8 screw

B526-66 screws (used to secure F952-3 plates to F050-2 stabilizer) are not interchangeable with other screws.

NOTE
B526 screws are compatible with T20 or 20IP drivers.

16-70 Antenna Locations

NO. ANTENNA	MHz	PART NO.	NO. ANTENNA	MHz	PART NO.
1 ADF	—	KA44B	12 Upper Fwd FM	800-870	CI 306
2 Marker Beacon	—	CI 102	Upper Fwd COM/GPS	—	CI 2580-200
3 Transponder/ADS-B/DME	—	CI 105-16, KA60	Upper Fwd GPS	—	GA 35
4 RH Belly UHF	400-960	CI 285	13 Upper Mid RSM/GPS . . .	—	910-00003-004 (Ant)
5 Transponder/ADS-B/DME	—	CI 105-16, KA60	Upper Mid RSM/GPS . . .	—	921-00003-001 (Kit)
6 Transponder/ADS-B/DME	—	CI 105-16, KA60	Upper Mid GPS	—	GA 35
7 LH/RH Belly (Ref)	—	See no.s 8 and 9	Upper Mid COM/GPS . . .	—	Provisions
8 RH Belly FM	138-174	CI 292-3 or DM C63-3/A*	14 Upper Aft COM	—	CI 121, CI 248-5
RH Belly FM	450-470	CI 177-20	Upper Aft FM	—	CI 177
RH Belly AM/FM (ENG) . .	—	CI 222	Upper Aft COM/GPS . . .	—	CI 2580-200
RH Belly FM	403-512	CI 273, CI 272-1, CI 271	Upper Aft FM	403-512	CI 273, CI 272-1, CI 271
9 LH Belly FM	138-174	CI 292-3 or DM C63-3/A*	Upper Aft COM/GPS . . .	—	Provisions
LH Belly FM	—	CI 177-20	15 Lower Fwd FM	—	CI 177
LH Belly FM	220-225	D721-1	Lower Fwd FM	403-512	CI 273, CI 272-1, CI 271
LH Belly FM	403-512	CI 273, CI 272-1, CI 271	Lower Fwd FM	800-870	CI 306
LH Belly COM	118-136	CI 122	16 Lower Aft FM	—	CI 177
10 ELT	—	AV-300	Lower Aft VHF	118-136	CI 122
11 Cowling GPS	—	GA 35	Lower Aft FM	403-512	CI 273, CI 272-1, CI 271
Cowling XM	—	GA 55	Lower Aft FM	800-870	CI 306
12 Upper Fwd COM	—	CI 121, CI 248-5	17 NAV	108-118	D20543 (VOR &
Upper Fwd FM	—	CI 177	& 18	& 329-335	LOCALIZER)
Upper Fwd FM	403-512	CI 273, CI 272-1, CI 271	NAV	108-118	D20543 (VOR &
				& 329-335	LOCALIZER W/DIPLEXER)

* For FT900R FM Receiver

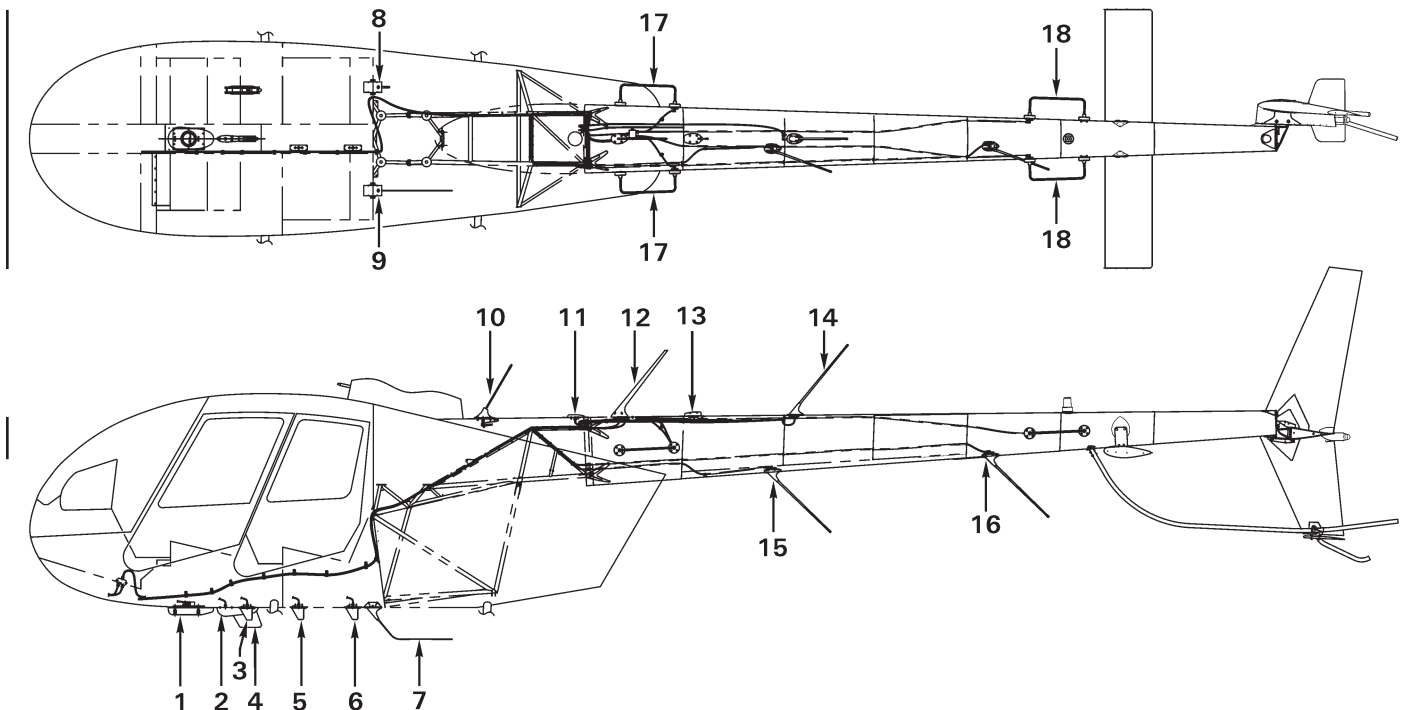

C850 REV AP

FIGURE 16-5 ANTENNA LOCATIONS

CHAPTER 17

JACKING AND HOISTING

<u>Section</u>	<u>Title</u>	<u>Page</u>
17-10	Jacking	17.1
17-20	Hoisting	17.5

Intentionally Blank

CHAPTER 17**JACKING AND HOISTING**17-10 Jacking**CAUTION**

When jacking helicopter, use mechanical or locking hydraulic jacks, when available. Unlocked hydraulic jacks are subject to pressure-loss which can affect critical measurements during leveling or cause a raised helicopter to become unstable.

CAUTION

Never jack helicopter in windy conditions.

CAUTION

Perform jacking on a clean, flat, hard surface free of water, oil, solvent, grease, or residue that could cause equipment or personnel to slip during jacking procedure.

CAUTION

Do not actuate jacks from underneath helicopter. Remain clear of landing gear skid tubes when helicopter is raised.

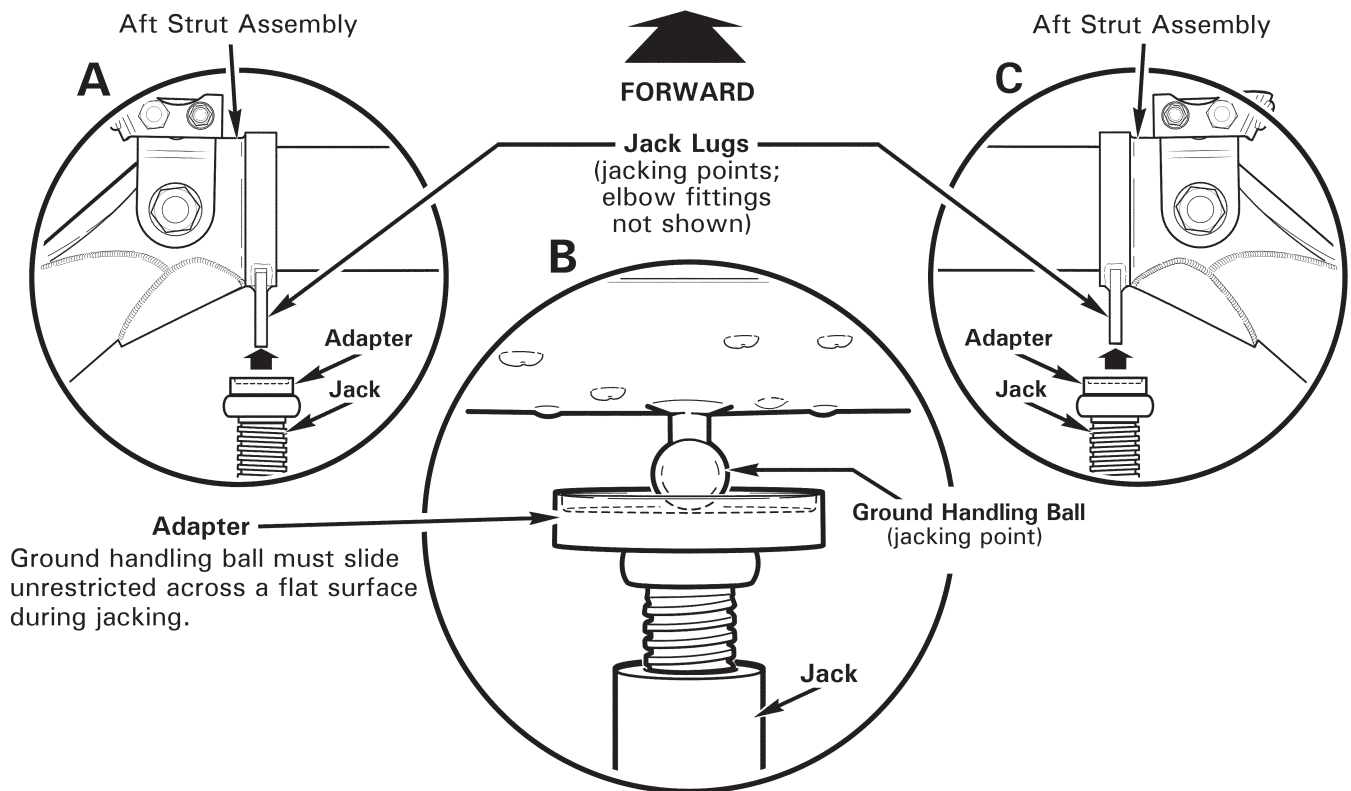
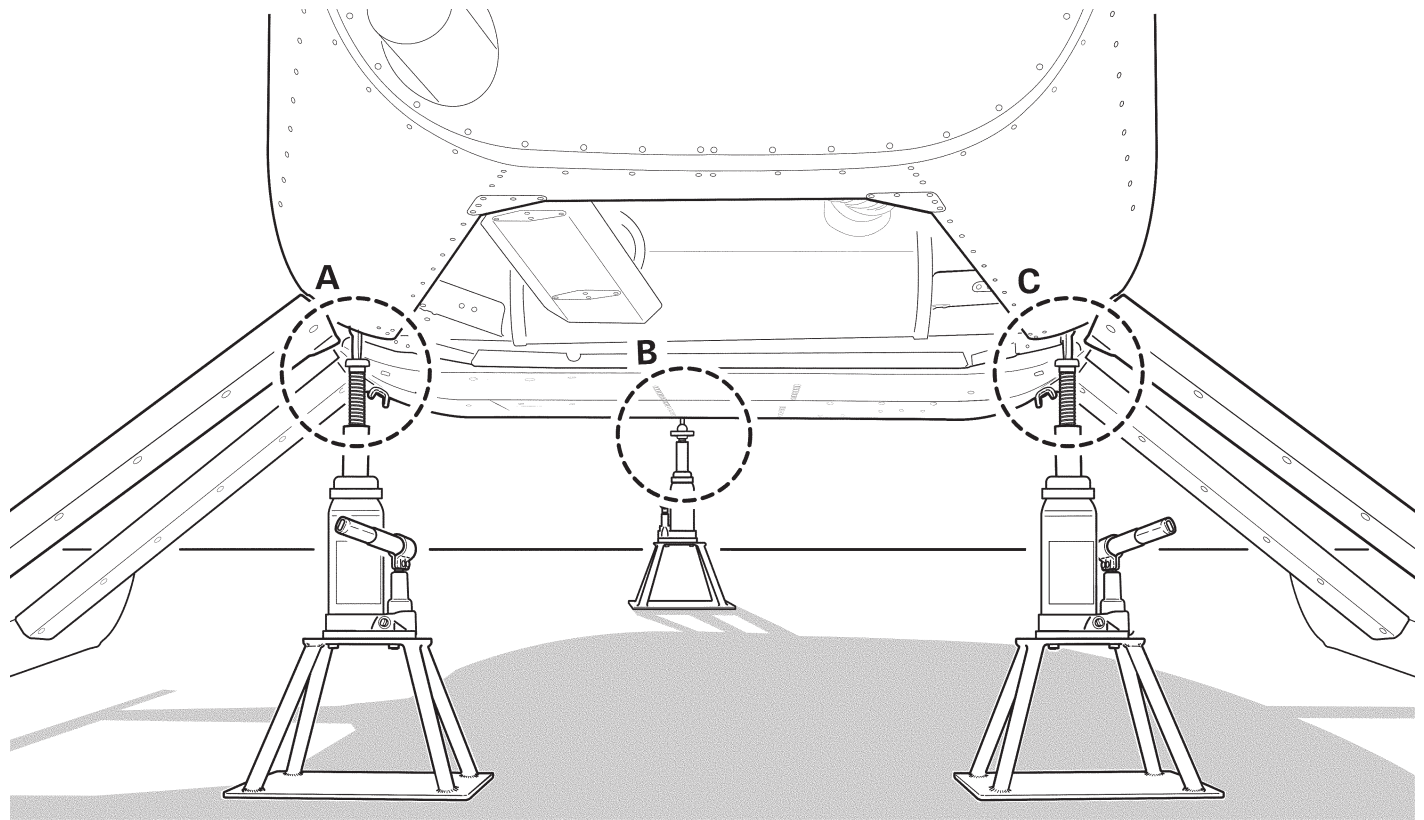

FIGURE 17-1 JACKING

17-10 Jacking (continued)**A. Jacking**

1. Refer to Figure 17-1. Place one (appropriate capacity) jack under each landing gear aft strut assembly jack lug (or aft cross tube, one inch inboard of elbow fittings or struts), and one under ground handling ball. Install jacking point adapters as required.

CAUTION

Ground handling ball must slide unrestricted across a flat surface during jacking to avoid side loading ball.

2. Position jack levers for convenient access and engage jacks at lugs (or cross tube) and ball. Sandbag jacks for increased stability, as required.
3. Actuate jacks slowly and simultaneously (one person per jack recommended), maintaining helicopter stability. Raise helicopter to required height.

CAUTION

Minimize personnel movement around raised helicopter.

B. Lowering**CAUTION**

Skids spread as aircraft weight settles on landing gear.

1. Refer to Figure 17-1. Slowly and simultaneously (one person per jack recommended) lower each jack ram, maintaining helicopter stability. Lower aircraft to ground.
2. Clear jacking equipment from area.

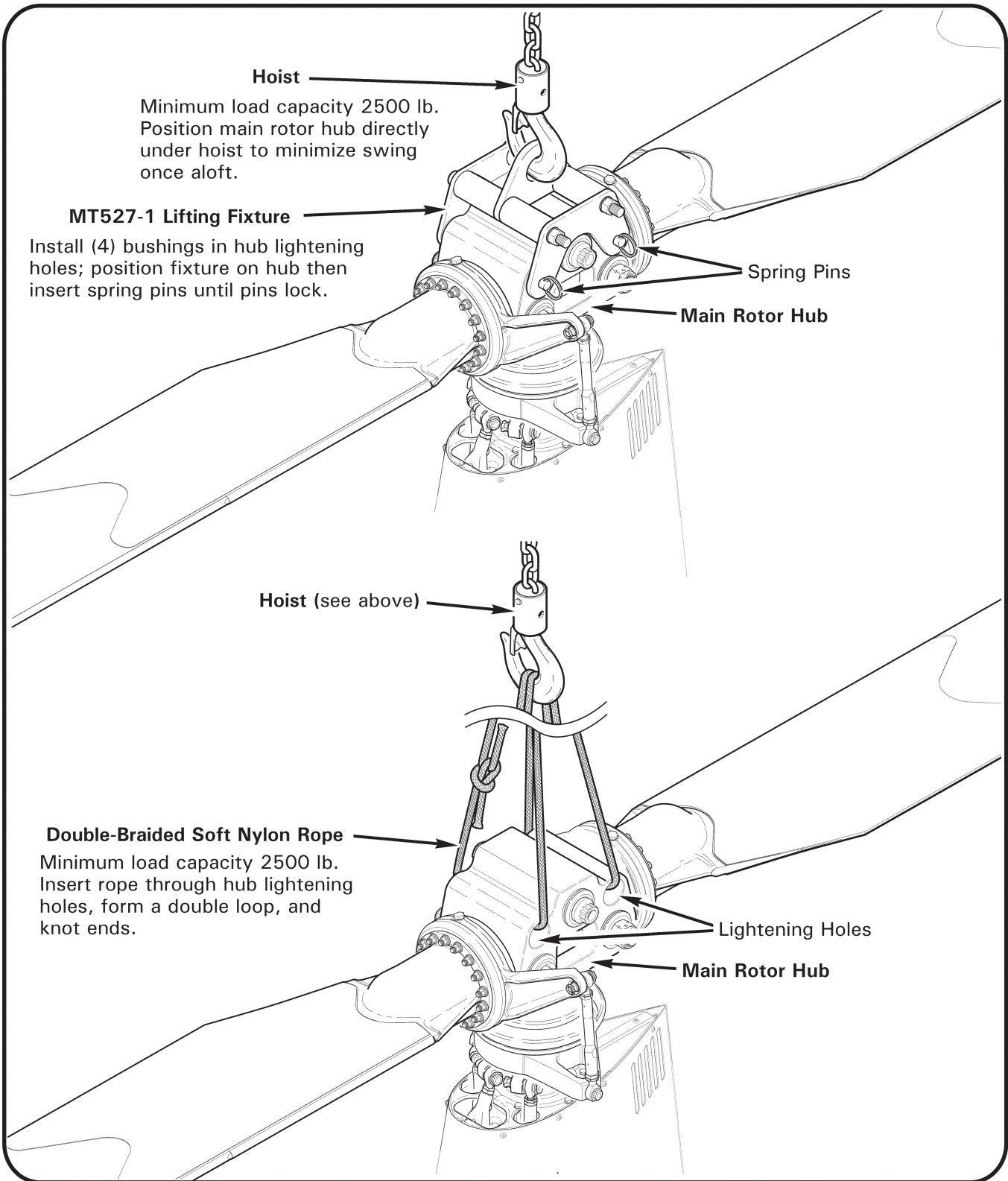

FIGURE 17-2 HOISTING

17-20 Hoisting**CAUTION**

Avoid hoisting helicopter in windy conditions.

CAUTION

Verify ground is free of water, oil, solvent, grease, or residue that could cause equipment or personnel to slip during hoisting procedure.

CAUTION

Remain clear of area beneath helicopter when helicopter is raised. Minimize personnel movement around raised helicopter.

A. Hoisting with Lifting Fixture

1. Refer to Figure 17-2. Verify hoisting equipment has minimum load capacity of 2500 lb.
2. Position main rotor hub directly under hoist to minimize helicopter swing once aloft.
3. Remove two spring pins and four nylon bushings from MT527-1 lifting fixture and install bushings in main rotor hub lightening holes. Position lifting fixture on hub then insert spring pins through fixture and bushings until pins lock. Verify security.
4. Connect hoist to lifting fixture. Verify security.
5. Stabilize helicopter as required by guiding tail skid, but do not exert force (tail skid is secondary structure). Raise helicopter to required height.

B. Hoisting with Nylon Rope

1. Refer to Figure 17-2. Verify hoisting equipment has minimum load capacity of 2500 lb. Verify minimum work load limit for 1-inch diameter twisted or double braided (preferred) soft nylon rope is 2500 lb.
2. Position main rotor hub directly under hoist to minimize helicopter swing once aloft.
3. Insert rope through main rotor hub lightening holes, form a double loop, and knot ends. Connect hoist to nylon rope. Verify security.
4. Stabilize helicopter as required by guiding tail skid, but do not exert force (tail skid is secondary structure). Raise helicopter to required height.

17-20 Hoisting (continued)**C. Lowering****CAUTION**

Skids spread as aircraft weight settles on landing gear.

1. Refer to Figure 17-2. Stabilize helicopter as required by guiding tail skid, but do not exert force (tail skid is secondary structure). Slowly lower aircraft to ground.
2. Disconnect hoisting equipment, remove lifting fixture or nylon rope from main rotor hub, and clear equipment from area.

CHAPTER 18**WEIGHT AND BALANCE**

<u>Section</u>	<u>Title</u>	<u>Page</u>
18-10	Leveling	18.1
18-11	Leveling Using Tailcone and Aft Landing Gear Cross Tube	18.3
18-12	Leveling at Main Rotor Hub	18.3
18-20	Weighing and CG Calculation	18.4
18-21	Preparing Helicopter for Weighing	18.4
18-22	Weighing Procedure and Calculations	18.5
18-30	Fixed Ballast	18.9
18-31	Nose Ballast	18.9
18-32	Empennage Ballast	18.10

Intentionally Blank

CHAPTER 18**WEIGHT AND BALANCE**18-10 Leveling**NOTE**

Perform leveling and weighing in a zero-wind environment.

NOTE

Verify spirit level is calibrated by placing level on a designated surface and noting bubble position. Rotate spirit level 180°; verify bubble is in the same position.

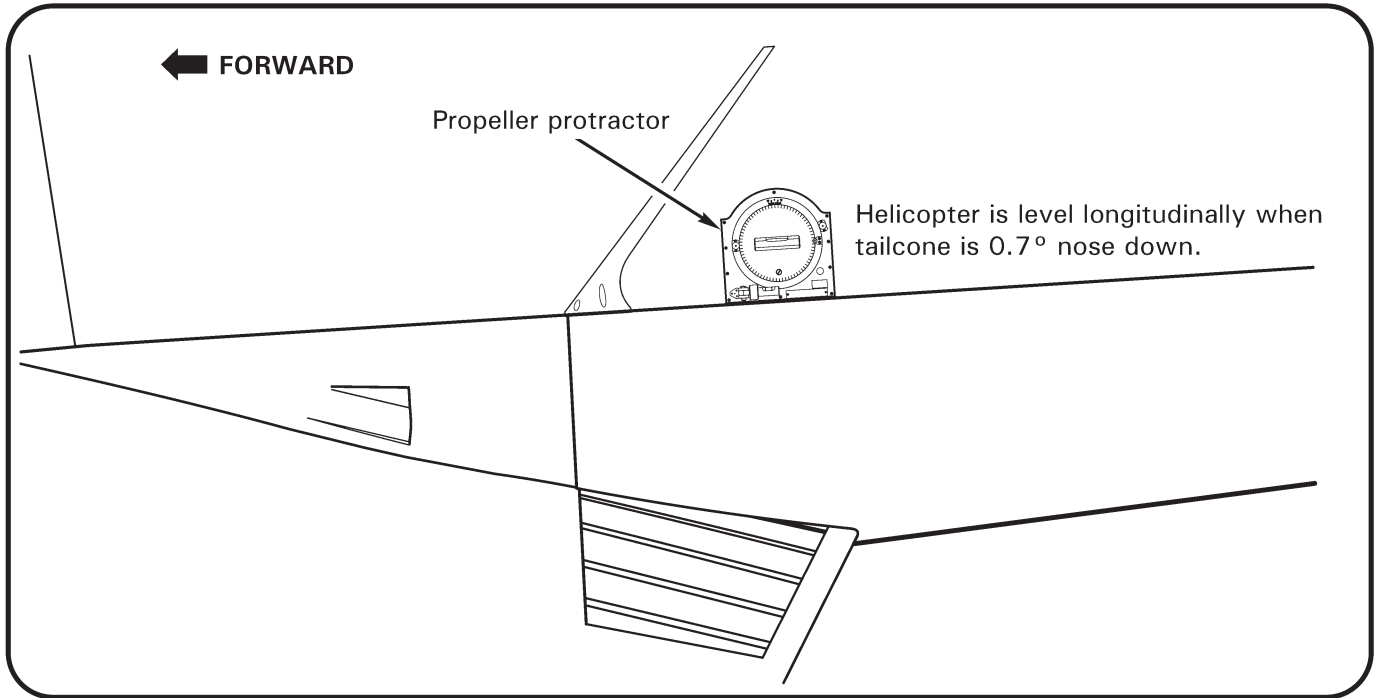

FIGURE 18-1 LEVELING USING TAILCONE

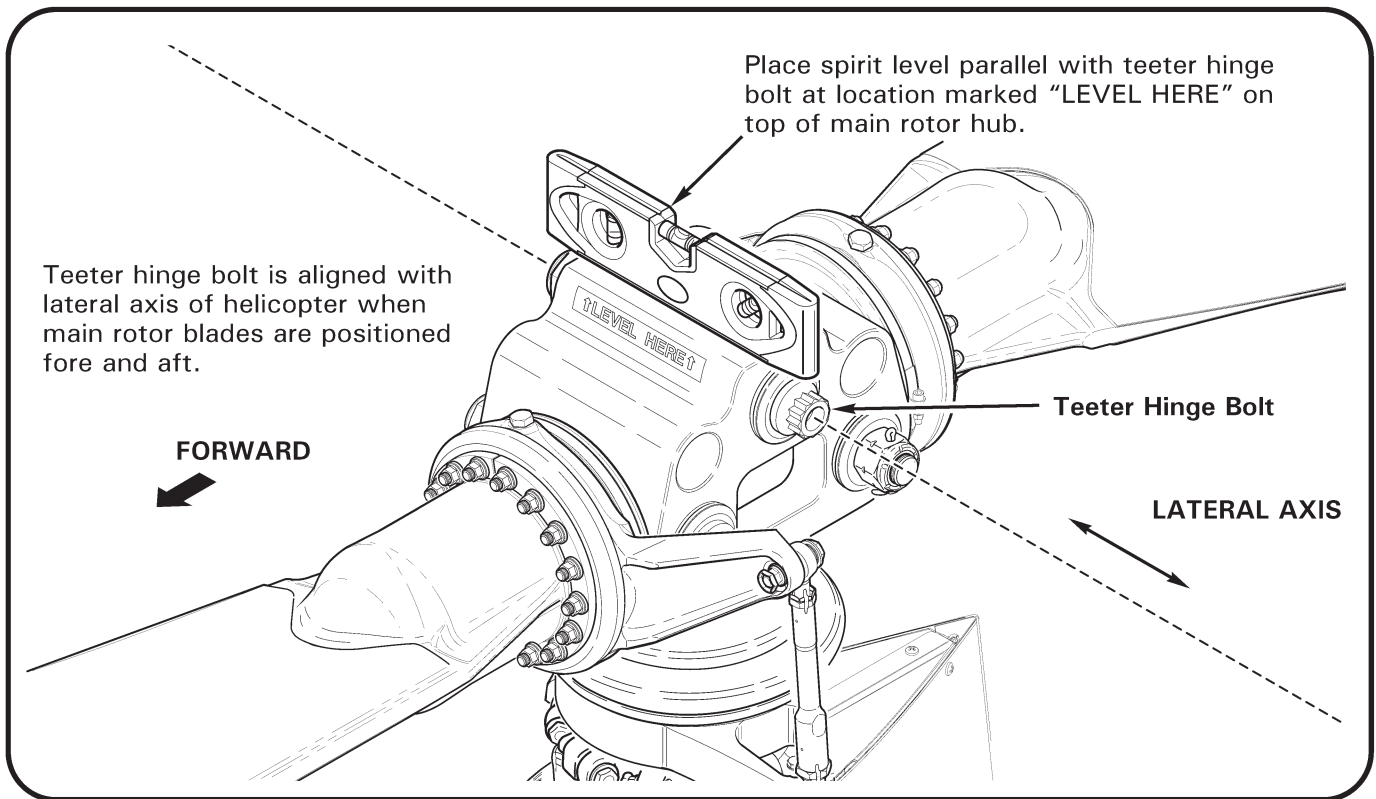

FIGURE 18-2 LEVELING AT MAIN ROTOR HUB
(Lateral shown)

18-11 Leveling Using Tailcone and Aft Landing Gear Cross Tube

1. Refer to Figure 18-1. Place a propeller protractor or digital level on top of tailcone forward bay.
2. Level helicopter longitudinally by placing shims under landing gear skid tubes or jacking per § 17-10. Helicopter is level longitudinally when tailcone is 0.7° nose down.
3. Verify aft cross tube is not bent. Place a level on center of aft cross tube.
4. Level helicopter laterally by placing shims under landing gear skid tubes or jacking per § 17-10.
5. Recheck longitudinal level. Repeat steps 2 thru 4 as required.

18-12 Leveling at Main Rotor Hub

1. Inspect main gearbox (4) rubber mounts. Verify no deterioration. Replace mount(s) if deteriorated.
2. Rotate main rotor until teeter hinge bolt is aligned with longitudinal axis of helicopter.
3. Refer to Figure 18-2. Place a spirit level atop main rotor hub parallel to teeter hinge bolt at location marked "LEVEL HERE".
4. Level helicopter longitudinally by placing shims under landing gear skid tubes or jacking per § 17-10.
5. Rotate main rotor until teeter hinge bolt is aligned with lateral axis of helicopter.
6. Level helicopter laterally by placing shims under landing gear skid tubes or jacking per § 17-10
7. Recheck longitudinal level. Repeat steps 3 thru 5 as required.

18-20 Weighing

Reweigh helicopter when helicopter empty weight and empty weight center of gravity have been modified, or if accuracy of data is suspect.

Maintain a continuous record of the helicopter's weight and balance using the Weight and Balance Record in applicable Pilot's Operating Handbook (POH) Section 6.

NOTE

Verify scales are calibrated. Operate scales according to scale manufacturer's instructions.

NOTE

Never weigh helicopter in wind. Weigh helicopter on a level, flat, hard surface in a zero-wind environment for accurate scale readings.

18-21 Preparing Helicopter for Weighing

1. Defuel helicopter per § 1.150, including gascolator and both fuel tank sumps.
2. Service engine oil, hydraulic fluid, and main & tail rotor gearboxes per Chapter 1.
3. Clean aircraft per § 23-10. Ensure helicopter is completely dry prior to weighing.
4. Remove items that are not installed equipment (tools, rags, charts, etc.) from baggage compartments and stowage areas.
5. Verify cowlings, removable panels, cabin doors, removable controls, and applicable Pilot's Operating Handbook (POH) are installed.
6. Verify Equipment List/Weight and Balance Data sheet (RF 134) and modifications recorded in the Weight and Balance Record correspond with installed equipment and recorded equipment locations.

18-22 Weighing Procedure and Calculations

NOTE

- Arm is the distance in inches from datum.
- Datum is located 100 inches forward of main rotor centerline.
- CG (arm) is determined by dividing total moment by total weight.

1. Refer to § 18-20. Prepare helicopter for weighing per § 18-21.
2. Hoist helicopter per § 17-20 approximately one foot above ground. Have one person hold tail skid while hoisting to stabilize helicopter.
3. With main rotor blades oriented approximately fore and aft, raise both blades off droop stops to allow hub to teeter freely. Raise tail slightly, release, and allow to settle.
4. Refer to Figure 18-3. With aircraft hanging freely and steady, use a water level and measure difference in vertical height between tail rotor gearbox centerline and cabin belly at vertical firewall. Ensure no air bubbles in water level tube.

Record height difference: _____ inches

5. Slowly lower both main rotor blades. Determine uncorrected longitudinal center of gravity:

114.34 – [0.32 x (height difference from step 4)] = _____ inches

6. Place a 1000-lb capacity (minimum) scale under each skid. Locate center of scales approximately 6 inches forward of ground handling wheel supports.
7. Lower helicopter until it rests entirely on scales. Helicopter must be well balanced on scales before releasing tail. Be sure helicopter is level laterally by placing level on center of aft landing gear cross tube.
8. Determine uncorrected empty weight:

Right scale reading: _____ lb

Left scale reading: + _____ lb

Tare (leveling shims, hoist fixture, etc.): – _____ lb

Uncorrected empty weight: = _____ lb

9. Calculate CG with full fuel and 150 lb pilot:

$$\frac{[(CG \text{ from step 5}) \times (\text{Empty weight from step 8})] + 37333}{(\text{Empty weight from step 8}) + 436.2} = \text{_____ inches}$$

Adjust ballast per step 10 as required until calculated CG is between 101.5 and 102.5 inches.

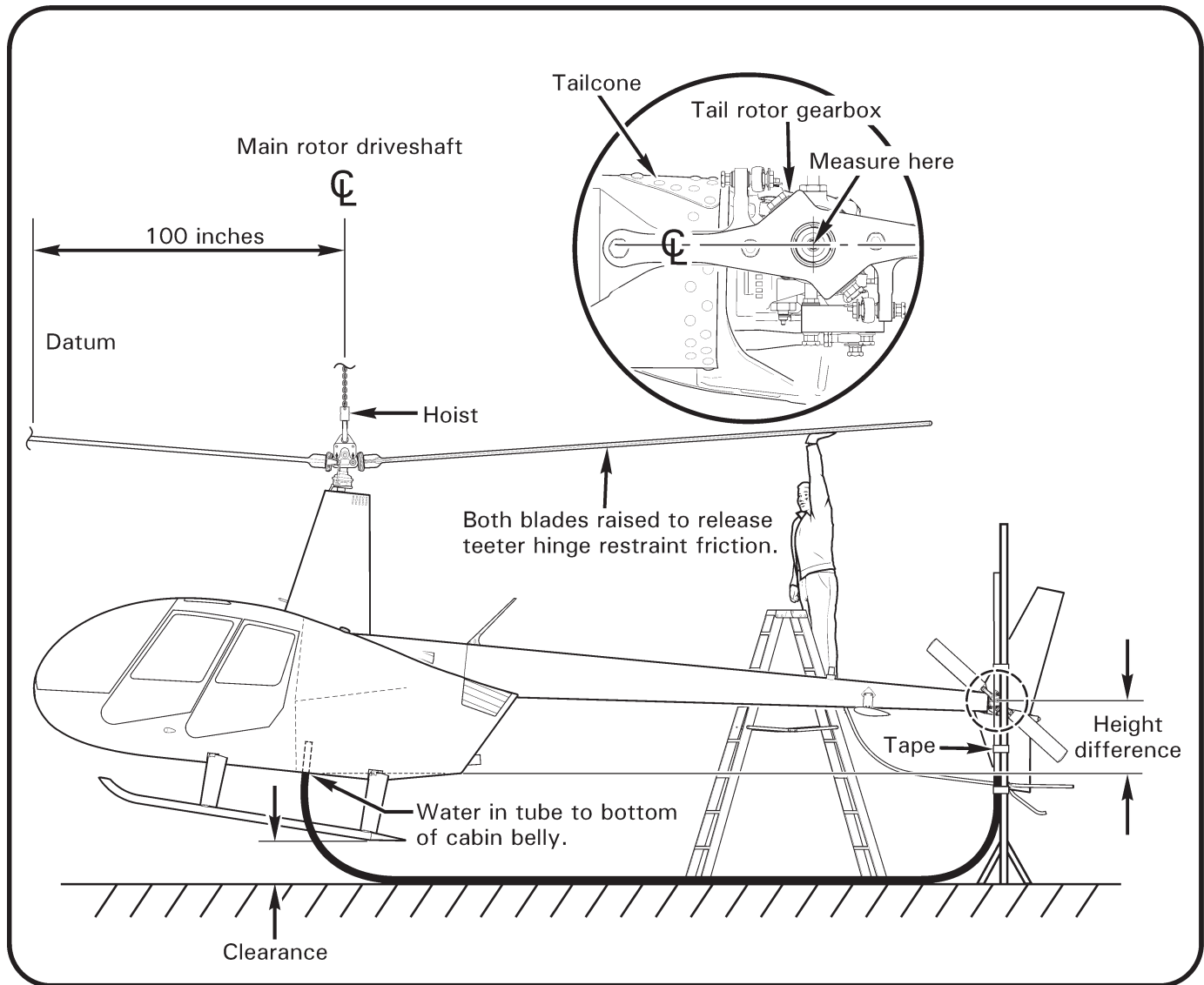

FIGURE 18-3 DETERMINING CG USING WATER LEVEL

18-22 Weighing Procedure and Calculations (continued)

10. a. If calculated CG from step 9 is aft of 102.5 inches, determine nose ballast required:

$$\frac{[(CG \text{ from step 5} - 102.5) \times (\text{Empty weight from step 8})] - 7378}{95.5} = \text{_____ lb}$$

Round ballast weight up to nearest 0.25 lb: _____ lb

Install nose ballast per § 18-31. Repeat steps 2 thru 10 and revise measurements and calculations.

b. If calculated CG from step 9 is forward of 101.5 inches and nose ballast is installed, determine nose ballast to remove:

$$\frac{(102.5 - \text{Calculated CG from step 9}) \times (\text{Empty weight from step 8} + 436.2)}{95.5} = \text{_____ lb}$$

Round ballast weight down to nearest 0.25 lb: _____ lb

Remove nose ballast per § 18-31. Repeat steps 2 thru 10 and revise measurements and calculations.

c. If calculated CG from step 9 is forward of 101.5 inches and nose ballast is not installed, install empennage ballast per § 18-32. Repeat steps 2 thru 10 and revise measurements and calculations.

11. Adjust weight and balance to correct for drained unusable fuel:

Item	Weight (lb)		Longitudinal CG (arm, inches)		Moment (in.-lb)
Helicopter as weighed	_____	x	_____	=	_____
	<i>(step 8)</i>		<i>(step 5)</i>		
Unusable fuel (add):	+7.2	x	96.0	=	+691
Basic empty weight and CG (includes unusable fuel & full oil)	_____	x	_____	*	= _____

* CG location (arm) is determined by dividing total moment by total weight

CAUTION

Calculated CG with full fuel and 150 lb pilot must be at, or forward of, 102.5 inches aft CG limit.

12. Determine lateral center of gravity:

$$\frac{(\text{Right scale reading} - \text{Left scale reading})}{(\text{Right scale reading} + \text{Left scale reading})} \times 41.2 = \text{_____ inches}$$

13. Determine lateral moment:

(Basic Empty Weight) x (lateral CG) = _____ in.-lb

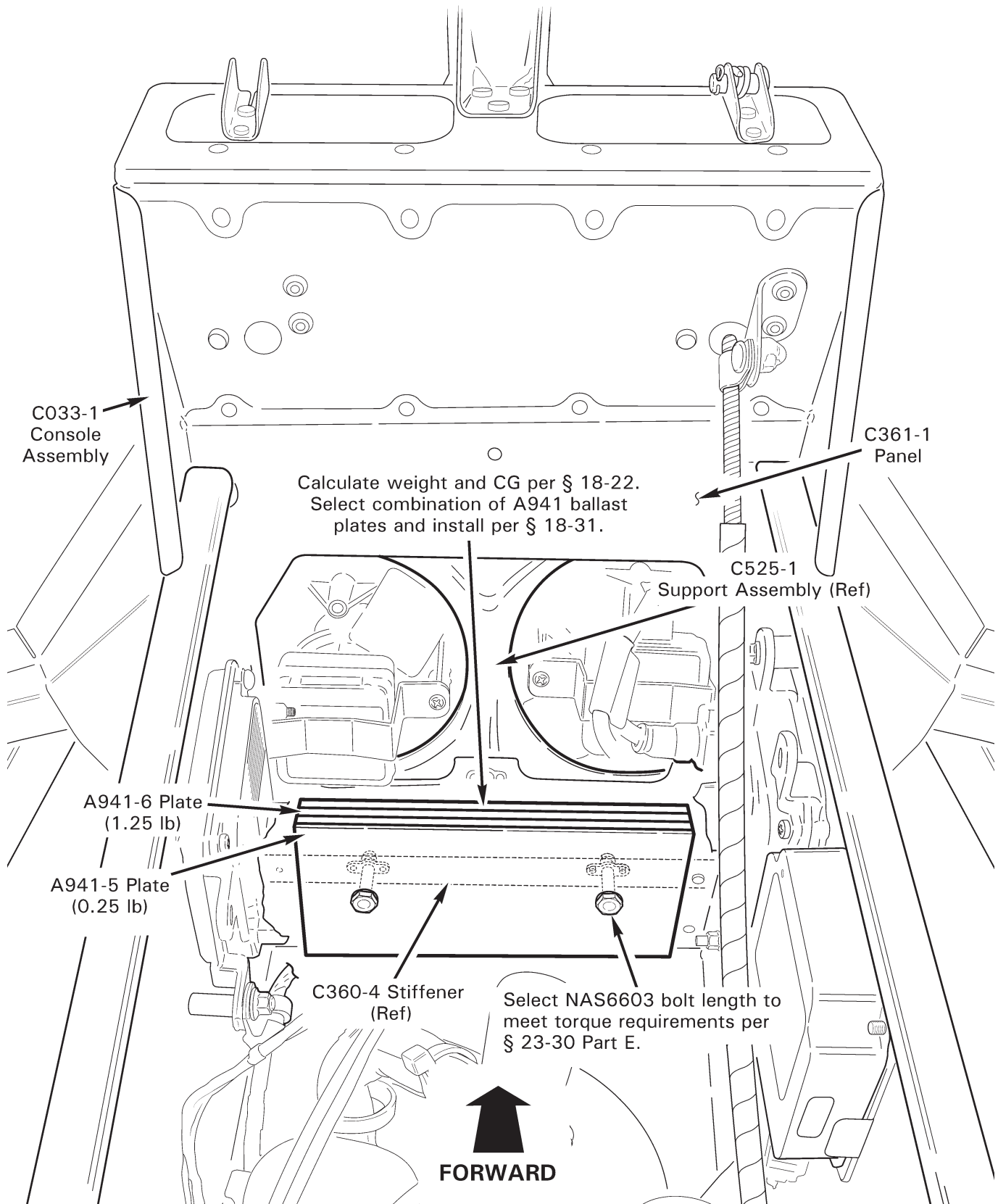

FIGURE 18-4 NOSE BALLAST
(View inside lower console assembly with upper console hinged aft)

18-30 Fixed Ballast

18-31 Nose Ballast

NOTE

Maximum allowable nose ballast is 20.00 lb if console assembly has C360-4 (or -2) stiffener installed, or 10.00 lb maximum without stiffener.

CAUTION

Changing fixed ballast amount affects helicopter empty weight & center of gravity (CG). If helicopter empty weight & CG historical data is suspect, weigh helicopter per § 18-20.

1. Open or remove console assembly per § 13-80.
2. As required, remove landing lights per § 26-13 to access ballast attaching hardware.
3. Refer to Figure 18-4. If installed, remove hardware securing A941-5 or -6 (or -2 or -3) ballast plate(s) to C361-1 panel.
4. Remove or install ballast plates per calculations performed in § 18-22. Select NAS6603 (or NAS428-3A) bolt length per to meet § 23-30 Part E.5. Install hardware, standard torque bolts per § 23-32, and torque stripe per Figure 2-1.
5. Install or close console assembly per § 13-80. Verify security.
6. Reweigh and/or calculate basic empty weight and CG per § 18-20.
7. Revise Weight and Balance Record in applicable Pilot's Operating Handbook (POH) Section 6 to reflect ballast removal or installation using the following data:

Item	Weight	Longitudinal Arm	Longitudinal Moment	Lateral Arm	Lateral Moment
Nose ballast	0–20.00 lb	7.0 in.	Variable	0.00 in.	0.00 in.-lb

18-32 Empennage Ballast**NOTE**

Approved materials are listed in § 23-70.

CAUTION

Changing fixed ballast amount affects helicopter empty weight & center of gravity (CG). If helicopter empty weight & CG historical data is suspect, weigh helicopter per § 18-20.

A. Removal**CAUTION**

Maximum allowable empennage ballast is 3.00 lb. One upper weight and one lower weight are required.

1. Remove D079-1 tail rotor guard per § 4.430.
2. Leaving NAS6606-78 bolts installed in C004-2, or F004-2 empennage assembly, remove palnuts, nuts, washers, and lower D301-2 ballast weight from empennage.
3. Remove one bolt then rotate upper ballast weight to expose empty bolt hole. Install NAS6606-47 bolt and associated hardware in exposed hole, finger tight (install [1] or [2] NAS1149F0663P washers as required under nut to meet § 23-30 Part E.5).
4. Remove second bolt & upper ballast weight from empennage assembly. Install NAS6606-47 bolt and associated hardware (install [1] or [2] NAS1149F0663P washers as required under nut to meet § 23-30 Part E.5). Standard torque bolts securing empennage to C148 bulkhead per § 23-32. Install palnuts and standard torque per § 23-32, do not torque stripe at this time.
5. As required, solvent-clean upper & lower surfaces of empennage assembly around and between attach bolts. Apply light coat zinc-chromate or epoxy primer to noted surfaces and hardware. Apply topcoat as desired.
6. Apply torque stripe to hardware per Figure 2-1.
7. Install tail rotor guard per § 4.430.
8. As required, weigh helicopter or calculate basic empty weight & CG per § 18-20.
9. Revise Weight and Balance Record in applicable Pilot's Operating Handbook (POH) Section 6 to reflect ballast removal using Table 8-1.

18-32 Empennage Ballast (continued)

B. Installation

CAUTION
 Maximum allowable empennage ballast is 3.00 lb. One upper weight and one lower weight are required.

1. Remove empennage assembly per § 4.400.
2. Solvent-clean around and between 0.375 inch diameter holes on upper & lower surfaces of F044-1 vertical stabilizers mount assembly or C044-1 horizontal stabilizer, as applicable.
3. Temporarily position two D301-2 weights on mount assembly (or horizontal stabilizer) using two NAS6606-78 bolts & associated hardware finger tight.
4. Trace outline of weights onto mount assembly (or horizontal stabilizer) upper & lower surfaces using felt-tip marker or tape. Remove weights.
5. Remove paint within traced outlines on mount assembly (or horizontal stabilizer) using approved stripper (ref. § 23-71), or by block sanding (to maintain flatness) using 320-grit or finer aluminum-oxide abrasive sandpaper.
6. Remove tracing tape, if installed. Solvent-clean bare metal on mount assembly (or horizontal stabilizer) & weight clamping surfaces. Conversion coat upper & lower bare metal surfaces of mount assembly (or horizontal stabilizer) per § 23-51.
7. Apply approved chromated-epoxy primer (ref. § 23-75) per § 23-60 to bare metal clamping surfaces of weights and mount assembly (or horizontal stabilizer). While primer is still wet, install empennage assembly per § 4.400.
8. As required, apply primer and topcoat to exposed hardware.
9. Weigh helicopter or calculate basic empty weight and CG per § 18-20.
10. Revise Weight and Balance Record in applicable Pilot’s Operating Handbook (POH) Section 6 to reflect ballast installation using Table 8-1.

Item	Weight	Longitudinal Arm	Longitudinal Moment	Lateral Arm	Lateral Moment
Empennage Ballast	3.0 lb	325.4 in.	976.2 in.-lb	4.45 in.	13.35 in.-lb

TABLE 8-1 EMPENNAGE BALLAST WEIGHT AND BALANCE

Intentionally Blank

CHAPTER 19
GROUND HANDLING

<u>Section</u>	<u>Title</u>	<u>Page</u>
19-00	Description	19.1

Intentionally Blank

CHAPTER 19**GROUND HANDLING**19-00 Description

Reserved.

Intentionally Blank

CHAPTER 20

PARKING AND STORAGE

<u>Section</u>	<u>Title</u>	<u>Page</u>
20-00	Description	20.1

Intentionally Blank

CHAPTER 20**PARKING AND STORAGE**20-00 Description

Reserved.

Intentionally Blank

CHAPTER 21

PLACARDS AND MARKINGS

<u>Section</u>	<u>Title</u>	<u>Page</u>
21-10	Placards and Markings	21.1

Intentionally Blank

CHAPTER 21**PLACARDS AND MARKINGS**21-10 Placards and Markings

Refer to R44 Illustrated Parts Catalog Chapter 11 for placard and marking locations.

A. Removal

To remove previously installed decals, start at corners and slowly peel off decal by hand or using a plastic wedge. Avoid damaging or removing paint or primer from surfaces. Remove decal entirely.

B. Installation

Verify surfaces are clean and dry before attaching decals. Use a clean cloth wet with acetone or mild soapy water to clean surfaces, but use caution when using acetone near silk-screened lettering on console and circuit breaker panel. Acetone can smudge or remove silk-screened letters. Attach decal and rub decal surface with finger, applying slight pressure.

Intentionally Blank

CHAPTER 22

SERVICING

<u>Section</u>	<u>Title</u>	<u>Page</u>
22-00	Description	22.1

Intentionally Blank

CHAPTER 22**SERVICING**22-00 Description

Reserved.

Intentionally Blank

CHAPTER 23

STANDARD PRACTICES

<u>Section</u>	<u>Title</u>	<u>Page</u>
23-10	Cleaning	23.1
23-20	Lubrication	23.3
23-30	Torque Requirements	23.5
23-31	Torque Stripe	23.7
23-32	Standard Torques	23.8
23-33	Special Torques	23.9
23-34	Push-Pull Tube Rod End Adjustment	23.15
23-35	D210-series Nuts on Critical Fasteners	23.15
23-36	A880 Flared Tube Components	23.16
23-40	Non-Destructive Testing	23.28
23-41	Magnetic Particle Inspection	23.28
23-42	Fluorescent Penetrant Inspection	23.29
23-50	Corrosion Control	23.29
23-51	Conversion Coat – Aluminum	23.29
23-60	Priming and Painting	23.30
23-70	Approved Materials	23.33
23-71	Paint Strippers	23.33
23-72	Solvents and Cleaners	23.33
23-73	Fillers and Putty	23.34
23-74	Torque Seal	23.34
23-75	Primers	23.35
23-76	Powder Coat	23.36
23-77	Paints	23.38
23-78	Lubricants	23.41
23-79	Adhesives and Sealants	23.42
23-80	Miscellaneous Practices	23.44
23-81	Part Interchangeability	23.44
23-82	Thermal Fitting Parts	23.44
23-83	Replacement Component Identification (Data) Plates	23.45
23-84	Crimp Inspection	23.45
23-85	Storage Limits	23.46
23-86	B526 Screws and B527-08 Washers	23.46

Intentionally Blank

CHAPTER 23

STANDARD PRACTICES

23-10 Cleaning**WARNING**

Review appropriate Safety Data Sheet (SDS) when working in proximity to hazardous materials. Specific recommendations for use of personal protective equipment are located in the SDS.

A. Cleaning Exterior Surfaces**CAUTION**

Refer to § 23-10 Part B for cleaning windshield and windows.

CAUTION

Never use high-pressure spray to clean helicopter. Never blow compressed air into main or tail rotor blade tip drain holes, pitot tube, or static ports.

CAUTION

Wash helicopter exterior surfaces with mild soap (pH between 7 & 9) and water. Harsh abrasives, alkaline soaps, or detergents can scratch painted or plastic surfaces, or cause corrosion of metal. Protect areas where cleaning solution could cause damage.

1. Rinse away loose dirt and debris from exterior surface with clean water.
2. Apply mild soap (pH between 7 & 9) and clean warm water solution to exterior surface using a clean, soft cloth, sponge, or soft bristle brush. Use caution near antennas and sensitive equipment.
3. Remove oil and grease using a cloth wetted with aliphatic naphtha.
4. Rinse all surfaces thoroughly.
5. If desired, polish painted surfaces with a good quality automotive wax using soft cleaning cloths, or a chamois cloth, free of abrasive debris.

23-10 Cleaning (continued)**B. Cleaning Windshield and Windows**

1. Remove dirt, mud, and other loose particles from exterior surfaces with clean water.
2. Wash with mild soap (pH between 7 & 9) and warm water or with aircraft plastic cleaner. Use a soft cloth or sponge in a straight back and forth motion. Do not rub harshly.
3. Remove oil and grease with a cloth moistened with isopropyl alcohol (rubbing alcohol) or aliphatic naphtha.

CAUTION

Do not use gasoline, other alcohols, benzene, carbon tetrachloride, thinner, acetone, or window (glass) cleaning sprays.

4. After cleaning plastic surfaces, apply a thin coat of hard polishing wax. Rub lightly with a soft cloth. Do not use a circular motion.

CAUTION

Windshield surface must be hydrophobic (water repellent) for good visibility in rain. When using a new cleaning or polishing product on windshield, verify water beads on surface before flying.

5. On acrylic windows (standard windshield), scratches can be removed by rubbing with jeweler's rouge followed by hand polishing with commercial plastic polish. Use a figure eight motion with polishing.

NOTE

Impact-resistant windshields are made from polycarbonate with a protective hardcoat and cannot be polished.

C. Cleaning Seat Assemblies and Back Rests

1. Vacuum and brush, then wipe with damp cloth. Dry immediately.
2. Soiled upholstery, except leather, may be cleaned with a good upholstery cleaner suitable for the material. Follow manufacturer's instructions. Avoid soaking or harsh rubbing.
3. Leather should be cleaned with saddle soap or a mild hard soap and water.

D. Cleaning Carpet

Remove loose dirt with a whisk broom or vacuum. For soiled spots and stains, use nonflammable dry cleaning liquid.

23-20 Lubrication**WARNING**

Review appropriate Safety Data Sheet (SDS) when working in proximity to hazardous materials. Specific recommendations for use of personal protective equipment are located in the SDS.

Most bearings are sealed or self-lubricated and do not require periodic lubrication. Bearings with scheduled lubrication intervals are listed in Table 1.

Engine lubrication requirements are located in the applicable Pilot's Operating Handbook, the appropriate model Lycoming Operator's Manual, and Lycoming Service Instruction No. 1014 (current revision).

Main and tail gearboxes and the hydraulic reservoir require servicing when indicated by sight gage level. Additionally, change gearbox oil or hydraulic fluid and clean respective sight gage when oil/fluid becomes so dirty its level cannot be determined. Change hydraulic oil if notably odorous.

WARNING

Use approved gearbox oils only (refer to R44 SL-73).

When installing a new or overhauled gearbox, drain and flush gearbox after the first 4 hours of flight or first chip light, whichever occurs first. Thereafter, change gearbox oil at intervals listed in Table 1.

Given

- Y = Unknown
- T = 135 in.-lb
- L = 10 in.
- A = 1.5 in.

Symbols

- Y = Torque wrench setting
- T = Torque applied to fastener
- L = Length of torque wrench
- A = Length of adapter

When using an adapter that lengthens torque wrench effective length, calculate torque wrench setting using the formula below:

EXAMPLE

$$\text{Solve for } Y = \frac{T \times L}{L + A} = \frac{135 \times 10}{10 + 1.5} = \frac{1350}{11.5} = 117.39$$

Set torque wrench to 117 in.-lb to torque fastener to 135 in.-lb.

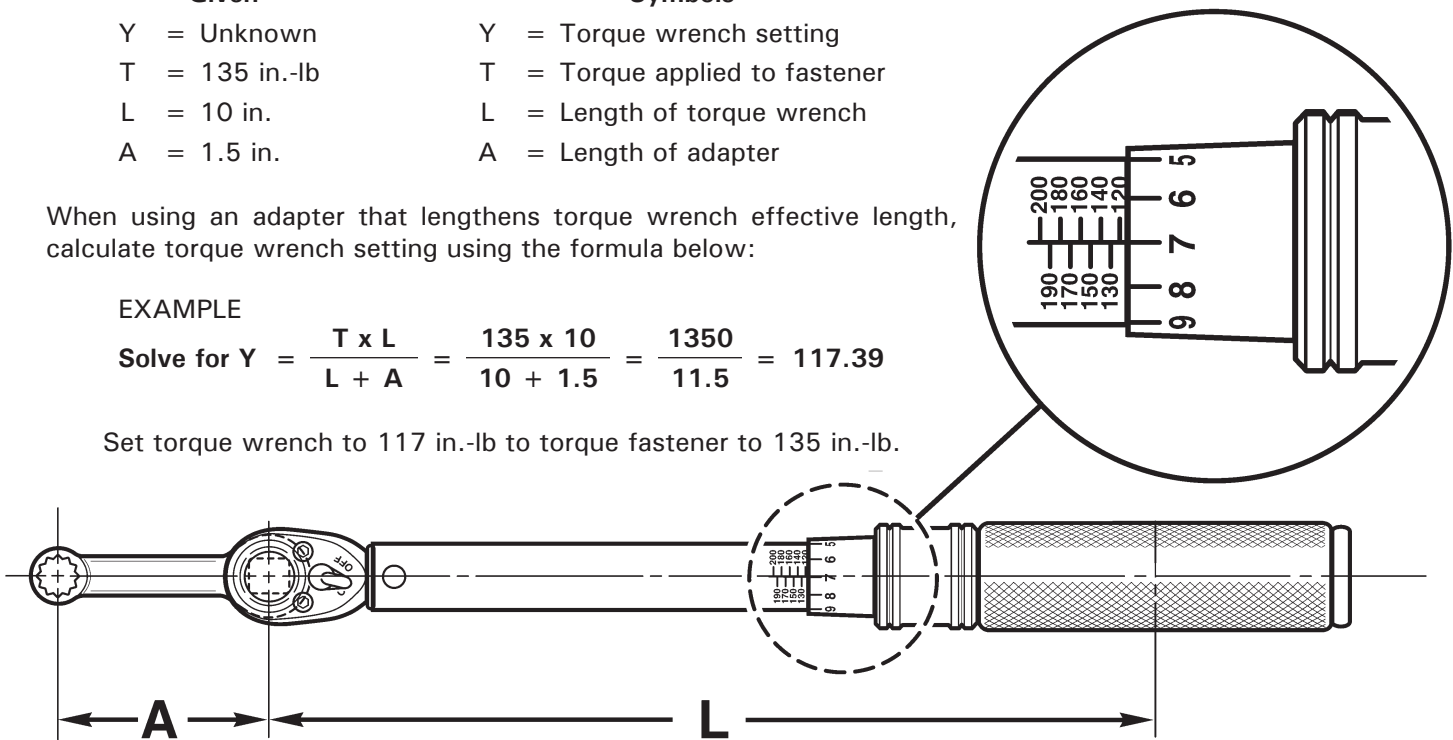

FIGURE 23-1 LENGTHENING TORQUE WRENCH EFFECTIVE LENGTH

Given

- Y = Unknown
- T = 135 in.-lb
- L = 10 in.
- A = 1.5 in.

Symbols

- Y = Torque wrench setting
- T = Torque applied to fastener
- L = Length of torque wrench
- A = Length of adapter

When using an adapter that shortens the torque wrench effective length, calculate torque wrench setting using the formula below:

EXAMPLE

$$\text{Solve for } Y = \frac{T \times L}{L - A} = \frac{135 \times 10}{10 - 1.5} = \frac{1350}{8.5} = 158.82$$

Set torque wrench to 159 in.-lb to torque fastener to 135 in.-lb.

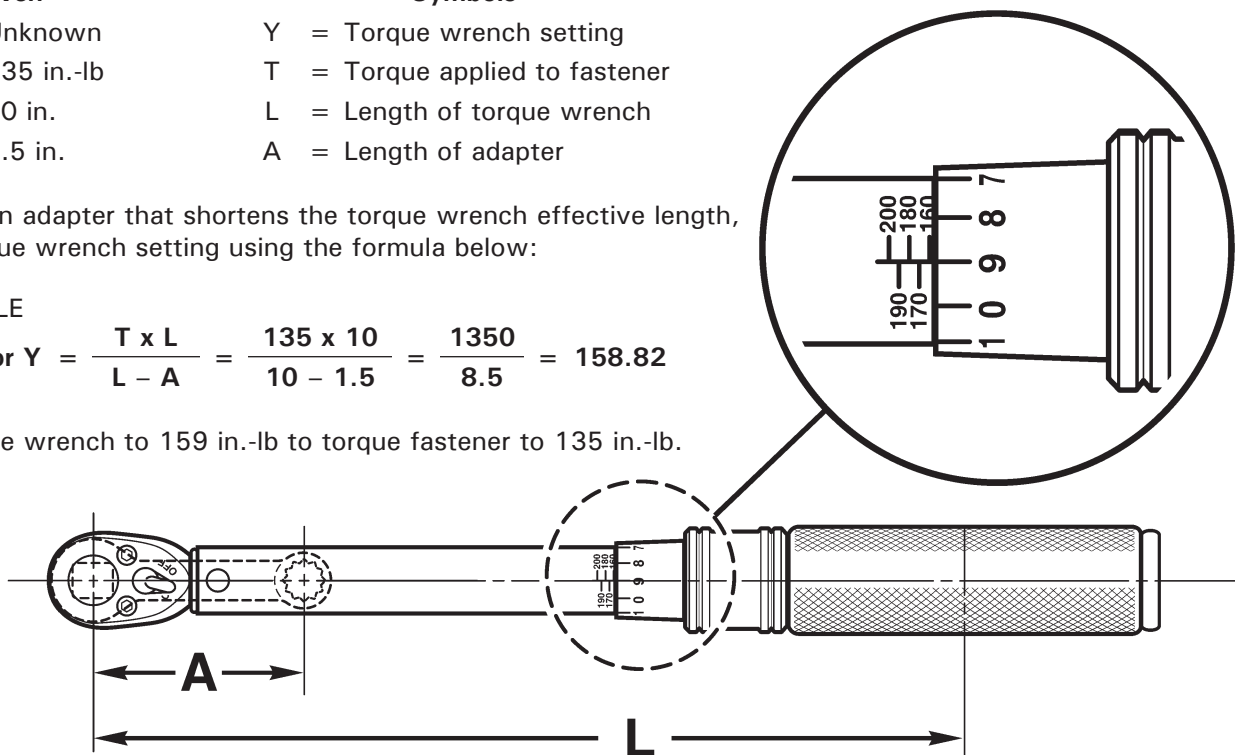

FIGURE 23-2 SHORTENING TORQUE WRENCH EFFECTIVE LENGTH

23-30 Torque Requirements

WARNING

Proper torque is critical. Always use calibrated wrenches and undamaged, properly lubricated (where applicable) hardware. Ensure clamping surfaces are clean, and clamp only bare metal or wet-primed surfaces. Improper torque or dirty or painted clamping surfaces may result in loss of clamp-up, hardware or part damage, and premature failure.

A. Tool Calibration

Dimensions and tolerances given in this manual are critical. Calibrate measuring tools per manufacturer’s recommendation at least once a year, when tool is dropped, misused, or calibration is suspect. Measuring tools include torque wrenches, micrometers, calipers, dial indicators, spring scales, protractors, and balancing equipment.

B. Torque Value

Torque fasteners to standard dry values listed in § 23-32 unless otherwise specified. If torque is applied by rotating bolt, increase torque value by 10% to account for higher friction at bolt head and shank.

For example, the torque wrench setting for an NAS6605 bolt used with an MS21075 nutplate is determined as follows:

NAS6605 bolt (5 indicates 5/16 inch size) dry torque per § 23-32	240 in.-lb
Add 10% because torque must be applied at bolt head	+ 24 in.-lb
Torque wrench setting	<u>264 in.-lb</u>

C. Secondary Locking Mechanism

A secondary locking mechanism is required on all critical fasteners. B330 stamped nuts (palnuts) serve as the secondary locking mechanism in most areas on the helicopter, and are torqued per § 23-32. Palnuts must be replaced when removed. The R44 Illustrated Parts Catalog (IPC) lists secondary locking mechanisms for specific fasteners.

23-30 Torque Requirements (continued)**D. Critical Fastener****CAUTION**

D210-series nuts, which supersede MS21042L-series and NAS1291-series nuts, are required on critical fasteners.

WARNING

Assembly of flight controls is critical and requires inspection by a qualified person. If a second person is not available, RHC recommends the installer take a 5-minute break prior to inspecting flight control connections installer has assembled.

A critical fastener is one which, if removed or lost, would jeopardize safe operation of the helicopter. This includes joints in the primary control system, and non-fail-safe structural joints in the airframe, landing gear, and drive system.

E. Torque Requirements**CAUTION**

Never substitute AN bolts for NAS bolts. NAS bolts have higher tensile strength.

1. Any self-locking nut whose drag has deteriorated appreciably must be replaced. Damaged hardware must be replaced.
2. Bolt and nut are to be clean and dry except when assembly procedure specifies anti-seize or thread-locking compound.
3. If chattering or jerking occurs, disassemble and re-torque fastener.
4. If special adapters which change effective length of torque wrench are used, final torque value must be calculated using formulas in Figures 23-1 and 23-2.
5. Unless otherwise specified, proper thread engagement requires:
 - a. If palnut is not required, one to four threads exposed beyond primary nut.
 - b. If palnut is required, two to four threads exposed beyond primary nut.
 - c. For B526-8 screws, one to five threads exposed beyond primary nut.

WARNING

Proper thread engagement ensures proper locking of fastener. Exceeding maximum thread exposure beyond primary nut may allow nut to seat against unthreaded shank, resulting in insufficient joint clamping.

6. Refer to Part A. Torque wrenches must be calibrated annually, when dropped, or when a calibration error is suspected.

23-31 Torque Stripe**WARNING**

Review appropriate Safety Data Sheet (SDS) when working in proximity to hazardous materials. Specific recommendations for use of personal protective equipment are located in the SDS.

Refer to Figure 2-1. Lacquer-paint Torque Seal® is applied to all critical fasteners after palnut installation in a stripe ("torque stripe") extending from the fastener's exposed threads across both nuts and onto the component. Subsequent rotation of the nut or bolt can be detected visually. Position torque stripes for maximum visibility during preflight inspections. Approved Torque Seal® is listed in § 23-74.

If, during inspection, the remaining torque stripe on a fastener is insufficient to determine joint integrity, then remove accompanying palnut as required and apply specified torque to fastener. If fastener moves, disassemble joint and inspect parts for damage such as fretting, thread deformation, hole elongation, etc.; replace damaged parts. If fastener does not move, install new palnut as required & standard torque per § 23-32. Torque stripe fastener per § 23-31.

23-32 Standard Torques

NOTE

1. Torque values are in inch-pounds unless otherwise specified.
2. Torque values include nut self-locking torque.
3. Increase torque values 10% if torqued at bolt head.
4. Wet indicates threads lubricated with A257-9 anti-seize.
5. For elbow and tee fittings which require alignment, torque to indicated value, then tighten to desired position.
6. Tolerance is $\pm 10\%$ unless range is specified.
7. Unless otherwise specified, thread sizes 8-32 and smaller are not used for primary structure and do not require control of torques.

FASTENER SERIES		SIZE	EXAMPLE FASTENER	TORQUE (IN.-LB)
NAS6603 thru NAS6608 Bolts NAS1303 thru NAS1308 Bolts NAS623 Screws NAS1351 & NAS1352 Screws NAS600 thru NAS606 Screws		10-32	NAS6603	50
		1/4-28	NAS6604	120
		5/16-24	NAS6605	240
		3/8-24	NAS6606	350
		7/16-20	NAS6607	665
		1/2-20	NAS6608	995
A142 screws AN3 Bolts AN4 Bolts AN6 Bolts AN8 Bolts	AN502 Screws AN503 Screws AN509 Screws AN525 Screws MS24694 Screws MS27039 Screws	10-32	A142-1, -3, -4; AN3	37
		1/4-28	AN4	90
		3/8-24	AN6	280
		1/2-20	AN8	795
STAMPED NUTS (PALNUTS) Palnuts are to be used only once and replaced with new when removed.		10-32	B330-7 (MS27151-7)	6-15
		1/4-28	B330-13 (MS27151-13)	11-25
		5/16-24	B330-16 (MS27151-16)	20-40
		3/8-24	B330-19 (MS27151-19)	29-60
		7/16-20	B330-21 (MS27151-21)	42-85
		1/2-20	B330-24 (MS27151-24)	54-110
TAPERED PIPE THREADS		1/8-27	See note 5	60
			Straight fittings only	120
		1/4-18	See note 5	85
			Straight fittings only	170
		3/8-18	See note 5	110
			Straight fittings only	220
		1/2-14	See note 5	160
			Straight fittings only	320
3/4-14	See note 5	230		
	Straight fittings only	460		
ROD END JAM NUTS (AN315 and AN316)		10-32	AN315-3	15
		1/4-28	AN316-4	40
		5/16-24	AN316-5	80
		3/8-24	AN316-6	110

23-33 Special Torques

Special torques supersede standard torques listed in § 23-32.

NOTE	
1.	Torque values are in inch-pounds unless otherwise specified.
2.	Torque values include nut self-locking torque.
3.	Increase torque values 10% if torqued at bolt head.
4.	Wet indicates threads lubricated with A257-9 anti-seize.
5.	For elbow and tee fittings which require alignment, torque to indicated value, then tighten to desired position.
6.	Tolerance is ± 10% unless range is specified.
7.	Unless otherwise specified, thread sizes 8-32 and smaller are not used for primary structure and do not require control of torques.

AREA	(QUANTITY) FASTENER	TORQUE
AIR CONDITIONING	(2) AN824-8D nuts on D792-2 and D793-2 lines at firewall	360 in.-lb
	(3) D782-5 bolt, D782-4 bracket-to-engine	360 in.-lb
	D799-2 or -9 high pressure cutout switch	90 in.-lb
	D799-3 low pressure cutout switch	90 in.-lb
	MS21042L6 nut, compressor drive pulley retaining	300 in.-lb
	(4) nuts (engine mounting), D778-1 cartridge assembly	204 in.-lb
	nut, D792-2 line assy-to-evaporator	150 in.-lb wet w/ A257-20
	nut, D793-2 line assy-to-evaporator	210 in.-lb wet w/ A257-20
	nut, D794-1 hose assy-to-D793-2 line assy	210 in.-lb
	nut, D794-1 hose assy-to-D777-1 compressor assy	300 in.-lb wet w/ A257-20
	nut, D810-1 or -2 line assy-to-D777-1 compressor assy	210 in.-lb wet w/ A257-20
	nut, D810-1 or -2 line assy-to-D783-1 condenser	150 in.-lb wet w/ A257-20
	nut, D811-1 or -2 line assy-to-D783-1 condenser	150 in.-lb wet w/ A257-20
	nut, D811-1 or -2 line assy-to-D793-2 line assy	150 in.-lb
(4) valve cores (on servicing and cutout switches fittings)	4 in.-lb	
CYCLIC STICK	(2) NAS1352-3H14 screws, C683-4 damper (manual-controls)	40 in.-lb
DOOR HINGES AND GAS SPRINGS	(16) MS51861-37C screws, securing door hinge assemblies	36 in.-lb
	(2) 21FKF-518 (or 94830A030) nuts, securing C394-2 ball studs at aft doors	100 in.-lb
	(2) C394-2 ball stud, at forward doors, to frame (B270-10 adhesive on threads)	150 in.-lb
	(2) D575-2 and (2) D575-3 ball joints, at forward door D573-4 rods	37 in.-lb
DRIVE SYSTEM	C182-1 nut (2-inch socket) on C007-5 shaft assembly Note: Shaft assemblies with smaller nuts are obsolete	450–550 ft-lb wet w/ A257-9
	(6) NAS6608-42H bolts, lower sheave	900 in.-lb

23-33 Special Torques (continued)

AREA	(QUANTITY) FASTENER	TORQUE
ELECTRICAL	(2) bolts, lead-acid Concorde battery terminals	70 in.-lb
	(2) bolts, lithium-ion True-Blue battery terminals	65 in.-lb
EMPENNAGE	NAS1352-3-14P screw, D079-1 guard assembly	40 in.-lb
	(8) NAS6604-6 bolts, vertical stabilizer attach	185 in.-lb
FANWHEEL	C182-1 nut – see DRIVE SYSTEM (above)	
	(16) D210-3 nuts, cone-to-fanwheel	70 in.-lb
	(8) D210-5 nuts, hub	300 in.-lb
FLOATS, POP-OUT	(10) inlet check valve base	75–85 in.-lb
	(10) inlet check valve pivot (hose fitting) retainer	110–120 in.-lb
	(22) nuts on D674-1, -2, -3, -4, -5, & -6 hoses	230–260 in.-lb
	(4) nuts on D674-7 hoses	110–130 in.-lb
	D770-1, -2, -3, & -4 valve assemblies	40 in.-lb
FUEL SYSTEM (See also PRIMER SYSTEM)	(1) A457-11 or 6505-04-06-SS adapter nut, gascolator outlet	285 in.-lb
	(1) B254-3 strainer assembly, main tank	200 in.-lb wet w/ A257-9
	(1) B283-3 hose assembly, gascolator-to-carburetor (O-540)	120 in.-lb
	(1) B283-3 hose assembly, mechanical-to-electrical fuel pump (IO-540)	120 in.-lb
	(5) B289-1 screws/bolts, fuel quantity sender, self-sealing	37 in.-lb
	(1) nut, fuel quantity sender, ground wire	9 in.-lb
	(1) nut, fuel quantity sender, center stud	11 in.-lb
	(2) B330-25 palnuts, electrical fuel pump elbows (IO-540)	75 in.-lb
	(1) C595-4 hose assembly, D321-1 valve assembly-to-D453-3 tee (IO-540)	120 in.-lb
	(1) C741-1 line assembly, gascolator-to-fuel valve	285 in.-lb
	(1) D205-28 or D205-38 hose assembly, main tank-to-fuel valve	120 in.-lb
	(1) D205-29 hose assembly or C595-2 or -3 hose assembly, aux tank-to-main tank	120 in.-lb
	(1) D205-30 hose assembly, main tank-to-drain	100 in.-lb
	(1) D205-31 hose assembly or C595-4 hose assembly, D321-1 valve assembly-to-D453-3 tee (IO-540)	120 in.-lb; orient D205-31 hose assy elbow horizontal $\pm 5^\circ$
	(1) D210-4 nut, A455-1 plug-to-gascolator	70 in.-lb
(1) D321-1 valve assembly, aux tank	150 in.-lb; rotate connector so D205-31 hose fitting $80^\circ \pm 5^\circ$ aft, or C595-4 hose fitting is $55^\circ \pm 5^\circ$ aft	

23-33 Special Torques (continued)

AREA	(QUANTITY) FASTENER	TORQUE
FUEL SYSTEM (continued)	(2) D452-6 nuts, electrical fuel pump elbows (IO-540)	150 in.-lb
	(1) D453-4 tee, aux tank	200 in.-lb; orient in line w/D321 valve assembly within 5°
	(1) AN316-7R nut, relief valve connector-to-firewall (IO-540)	150 in.-lb
	(1) AN815-3D union or A880-933 or -963 union, main tank	100 in.-lb
	(1) AN815-6D union or A880-936 or -966 union, main tank	200 in.-lb
	(1) AN924-3D nut or A880-1003 nut, A761-1 drain-to-D255-1 connector	100 in.-lb
	(1) AN924-5D or A880-1005 nut, low fuel switch assy-to-D250-1 cover assy	150 in.-lb
	(1) CAV-110H-4 drain valve, or A761-1 drain valve, 10541 (cad plated steel) bowl, A666-1 gascolator assy	54–66 in.-lb
	(1) CAV-110H-4 drain valve, or A761-1 drain valve, B416-3 (aluminum) bowl, A666-1 gascolator assy	60 in.-lb
	(1) HTM-300 clamp, electrical fuel pump-to-D742-1 support assembly (IO-540)	100 in.-lb
	(1) MS21900D6 adapter or D319-4 fitting, mechanical fuel pump (IO-540)	150 in.-lb
(1) MS27769D2 plug, gascolator	60 in.-lb	
FUSELAGE	(2) NAS1351-6H20P bolts securing B253-2 anchor, with safety wire	150 in.-lb
	(2) NAS1351-6LE20P bolts securing B253-2 anchor, no safety wire	200 in.-lb
	(3) A964-2 eyebolts	250 in.-lb
	(1) D210-5 nut, ground handling ball	240 in.-lb
	(1) B277-072 clamp, mast fairing lower rib to mast tube	50 in.-lb
	(4) NAS6604-3 bolts, securing F050-2 stabilizer to tailcone	185 in.-lb
	(4) NAS6603-2 bolts, securing F050-2 stabilizer to F955-1 bracket	70 in.-lb
HYDRAULIC HOSES & FITTINGS	(2) B330-19 palnuts	30 in.-lb
	(3) B330-21 palnuts	45 in.-lb
	(1) B330-25 palnuts	75 in.-lb
	(1) AN820-4 cap, AN834-4D tee at hydraulic pump	60 in.-lb
	(1) AN820-6 cap, AN834-6D tee at hydraulic pump	120 in.-lb
	(2) D452-3 nuts	60 in.-lb
	(3) D452-4 nuts	90 in.-lb
	(1) D452-6 nut	150 in.-lb
	(1) D205-3, (1) -12, (1) -14 hose assemblies & (2) AN815-3D unions	95–105 in.-lb
	(1) D205-7, (1) -11, (2) -16 hose assemblies & (3) AN815-4D unions	135–150 in.-lb
	(1) D205-15 hose assembly & (1) AN815-6D union	190–210 in.-lb

23-33 Special Torques (continued)

AREA	(QUANTITY) FASTENER	TORQUE
HYDRAULIC PUMP	Hydraulic pump-to-gearbox mounting nuts (see MAIN ROTOR GEARBOX)	
HYDRAULIC RESERVOIR	(1) B563-3 sight gage	150 in.-lb
	(1) D487-3 vent assembly	100 in.-lb
	(1) D516-1 cap, filter	150 in.-lb
	(4) NAS1352-4-8P screw, reservoir-to-frame	80 in.-lb
HYDRAULIC SERVOS	MS27039C0806 screw attaching D200-2 scissors	25 in.-lb
	B330-6 palnut on above screw	5–10 in.-lb
LANDING GEAR	(8) B227-28 clamps, strut fairings	15 in.-lb
	(8) HTM-200 clamps, strut fairings	100 in.-lb wet w/ B270-10
	(4) NAS6604-46 bolts, ground handling wheel supports	70 in.-lb
	(4) NAS6607P20 bolts, gear attach (earlier ships) Note: NAS6607-20 bolts are standard torque per § 23-32.	66 ft-lb
MAIN ROTOR BLADE	(2) A722-4 screws, tip balance weight	40 in.-lb wet w/ A257-9
	(2) B289-2 bolts, self-sealing	70 in.-lb
	(1) C165-1 clamp, inner	Tighten to 2.850 ± 0.005 inch outside diameter (OD)
	(2) NAS1351N3-12P screws, tip cover-to-blade	40 in.-lb wet w/ A257-9
MAIN ROTOR FLIGHT CONTROLS	(2) MS35206-324 screws, low rotor RPM horn V3-1 switch	5 in.-lb
	(1) A430-3 tube, governor assembly linkage	20 in.-lb
MAIN ROTOR GEARBOX	(4) A650-4 fittings, gearbox mounting or (4) D210-10 nuts	50 ft-lb wet w/ A257-9, torqued from bolt head or nut
	(1) B563-2 sight gage	150 in.-lb
	(1) B566-1 chip detector housing	150 in.-lb
	chip detector (threaded type)	Approximately 75 in.-lb
	(4) D210-4 nuts, hydraulic pump-to-gearbox (or cover)	40 in.-lb
	(1) AN320-8 nut, gearbox pinion (retains C908 yoke)	35–45 ft-lb
	(1) AN814-8D filler plug	150 in.-lb
	(6) NAS1352-4H screws, end cover (safety wire is required)	120 in.-lb
	(6) NAS1352-4 screws, end cover (safety wire <u>not</u> required)	140 in.-lb
	(6) NAS1352-4H16P screws, sump-to-housing (safety wire is required)	120 in.-lb at head
(6) NAS1352-4-16 screws, sump-to-housing (safety wire <u>not</u> required)	140 in.-lb at head	

23-33 Special Torques (continued)

AREA	(QUANTITY) FASTENER	TORQUE
MAIN ROTOR HUB	(1) NAS634-105 bolt, teeter hinge and (2) NAS634-105 bolts, coning hinges	New bolt: 0.021–0.022 inch elongation, wet w/ A257-9 Used bolt: 0.020–0.022 inch elongation, wet w/ A257-9, and cotter pin holes must align
	<div style="border: 1px solid black; padding: 5px; width: fit-content; margin: 0 auto;"> <p>WARNING Scrap bolt & nut if bolt is elongated more than 0.024 inch during tightening.</p> </div>	
PITCH LINKS	21FKF-813 self-locking jam nut, main rotor pitch link	300 in.-lb
POWERPLANT	(4) bolts, air box-to-carburetor	30 in.-lb
	(2) bolts, engine-to-ground strap	96 in.-lb
	(6) bolts, D730-1 manifold weldment-to-engine	96 in.-lb
	(4) engine hardware, securing C592-3 mount assembly	204 in.-lb
	(6) engine nuts, securing C357-1 clips	96 in.-lb
	(1) hardware, securing alternator to B200-3 or D728-1 arm	204 in.-lb
	(4) nuts, carburetor-to-engine (O-540)	96 in.-lb initial, 204 in.-lb final; torque in crisscross pattern
	(1) nut, A457-9 tee	140 in.-lb
	(1) nut, A462 fitting on mixture control arm	27 in.-lb
	(12) spark plugs	420 in.-lb wet w/ A257-16
	(1) A058-10 probe	36–48 in.-lb
	(1) A723-15 line assembly, nuts	40 ft-lb
	(1) B173 v-belt, tension at alternator	150–170 in.-lb initial drag at pulley
	(1) B283-7 hose assembly, nuts	140 in.-lb
	(1) B283-10 hose assembly, nuts	140 in.-lb
	(1) B283-11 hose assembly, nuts	140 in.-lb
	(1) C740-4 line assembly, nuts	30 in.-lb
	(1) D740-1 line assembly, nuts	30 in.-lb
	(1) D753-1 line assembly, nuts	40 ft-lb
	(1) D753-2 line assembly, nuts	40 ft-lb
	(2) MS20074-05-04 bolt, alternator	204 in.-lb
	(1) MS20074-05-11 bolt, alternator	204 in.-lb
	(1) MS20074-06-07 bolt, alternator	280 in.-lb
(4) NAS1352-6H48P screw, securing C593-3 mount assy	280 in.-lb	
(3) STD-1411 nuts, securing C357-3 clips	96 in.-lb	
(12) 21FKF-518 nuts, exhaust flange (draw up evenly prior to torquing)	200–220 in.-lb	
(1) 3080-00038 cylinder head temperature probe	75 in.-lb	

23-33 Special Torques (continued)

AREA	(QUANTITY) FASTENER	TORQUE
PRIMER SYSTEM (See also FUEL SYSTEM)	(1) D101-3, (1) D102-4, (2) D103-3, (1) D104-3, (1) D105-3, (1) D106-3, and (1) D107-3 line assembly, nuts	20–30 in.-lb
	(1) AN894D4-2 Bushing, at gasoclator	50–60 in.-lb
	(1) AN894D6-4 Bushing, at gasoclator	110–130 in.-lb
STEEL TUBE FRAME	(2) C722-2 5/8-inch internal-wrenching screws	120–125 ft-lb wet w/ A257-9
	(2) S14119 screw and (2) A31007 nut	10 in.-lb
SWASHPLATE	(18) AN503-8-8 fillister-head screws	17 in.-lb
	(26) NAS1352-08H8P socket-head screws	30 in.-lb
	(26) NAS1352N08-8 screws	35 in.-lb wet w/ A257-9
	(1) NAS6605-8 bolt clamping C203-1 yoke	190 in.-lb (opposite clamping bolt must be torqued first)
TAIL ROTOR	(1) NAS6606-53 bolt, elastomeric teeter (delta) hinge	420 in.-lb
TAIL ROTOR GEARBOX	(1) A610-1 vent assembly	100 in.-lb
	(1) B563-4 sight gage	150 in.-lb
	(1) B566-2 chip detector	100 in.-lb
	(1) D210-4 nut, securing C119-2 bumper to TRGB output shaft	120 in.-lb
	(1) D210-5 nut, pitch control housing stud	240 in.-lb
	(1) AN320-8 nut, C116-1 input yoke	35–45 ft-lb
	(4) MS20074-04-06 bolts, input cap	60 in.-lb
	(8) MS20074-04-06 bolts, input cartridge and output cap	100 in.-lb
	(4) NAS1352-5H12P drilled-head bolts, gearbox-to-tailcone attaching	200 in.-lb
	(4) NAS1352-5-12P bolts (undrilled), gearbox-to-tailcone attaching	240 in.-lb
WINDSHIELD	(22) AN526C832R12 screw, thru center brace	16 in.-lb
	(66) B526-6 screw, polycarbonate windshield	24 in.-lb

23-34 Push-Pull Tube Rod End Adjustment

NOTE

Refer to § 10.232 to adjust C258 main rotor pitch links.

The following procedure is standard for adjusting push-pull tube rod ends:

1. Loosen palnut and jam nut on rod end shank.
2. Remove hardware securing push-pull tube rod end to attachment point per respective instructions.
3. Screw rod end in or out of push-pull tube as required to obtain proper rigging adjustment. Apply B270-21 (corrosion) protectant to exposed threads.
4. After any rod end adjustment, verify rod end threaded shank blocks passage of 0.020-inch diameter wire thru the witness hole in the push-pull tube per Figure 2-1. When no witness hole is provided, refer to Figure 2-1 for maximum rod end extension.
5. Install fastener securing push-pull tube to attachment point per respective instructions.
6. Refer to Figure 2-1A. Position rod ends to allow as much push-pull tube rotation as possible without binding. Standard torque jam nuts & palnuts per § 23-32 & torque stripe per Figure 2-1.

23-35 D210-series Nuts on Critical Fasteners

When performing maintenance that involves disassembly of a critical fastener (joints with a secondary lock), reassemble the fastener using a D210-series nut.

If a fastener is disassembled that has an MS21042L-series or NAS1291-series nut with a B330-series palnut or B332-series lockwasher (secondary lock),

replace MS21042L08 nut or NAS1291-08 nut with D210-08 nut,
replace MS21042L3 nut or NAS1291-3 nut with D210-3 nut,
replace MS21042L4 nut or NAS1291-4 nut with D210-4 nut,
replace MS21042L5 nut or NAS1291-5 nut with D210-5 nut,
replace MS21042L6 nut or NAS1291-6 nut with D210-6 nut,
replace NAS1291-7 nut with D210-7 nut,
replace NAS1291-8 nut with D210-8 nut, or
replace NAS1291-10 nut with D210-10 nut.

23-36 A880 Flared Tube Components

A. Nuts – Flare

Dash Numbers	Allowable Part Numbers	Material REF	Tube OD REF
-102	AN818-2D, AN818-2W, AS5175W02	AL	1/8-inch
-103	AN818-3D, AN818-3W, AS5175W03	AL	3/16-inch
-104	AN818-4D, AN818-4W, AS5175W04	AL	1/4-inch
-105	AN818-5D, AN818-5W, AS5175W05	AL	5/16-inch
-106	AN818-6D, AN818-6W, AS5175W06	AL	3/8-inch
-108	AN818-8D, AN818-8W, AS5175W08	AL	1/2-inch
-110	AN818-10D, AN818-10W, AS5175W10	AL	5/8-inch
-202	AN818-2J, AS5175J02	CRES	1/8-inch
-203	AN818-3J, AS5175J03	CRES	3/16-inch
-204	AN818-4J, AS5175J04	CRES	1/4-inch
-205	AN818-5J, AS5175J05	CRES	5/16-inch
-206	AN818-6J, AS5175J06	CRES	3/8-inch
-208	AN818-8J, AS5175J08	CRES	1/2-inch
-210	AN818-10J, AS5175J10	CRES	5/8-inch

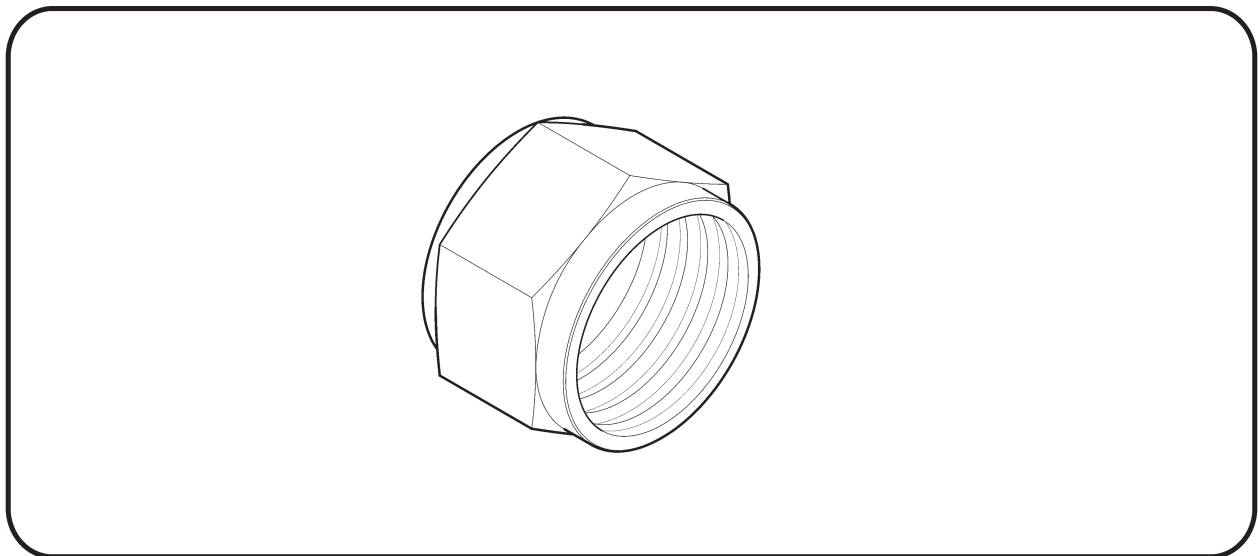

23-36 A880 Flared Tube Components (continued)

B. Sleeves

Dash Numbers	Allowable Part Numbers	Material REF	Tube OD REF
-302	MS20819-2D, AS3220D02, AS3220W02	AL	1/8-inch
-303	MS20819-3D, AS3220D03, AS3220W03	AL	3/16-inch
-304	MS20819-4D, AS3220D04, AS3220W04	AL	1/4-inch
-305	MS20819-5D, AS3220D05, AS3220W05	AL	5/16-inch
-306	MS20819-6D, AS3220D06, AS3220W06	AL	3/8-inch
-308	MS20819-8D, AS3220D08, AS3220W08	AL	1/2-inch
-310	MS20819-10D, AS3220D10, AS3220W10	AL	5/8-inch
-402	MS20819-2J, AS5176J02	CRES	1/8-inch
-403	MS20819-3J, AS5176J03	CRES	3/16-inch
-404	MS20819-4J, AS5176J04	CRES	1/4-inch
-405	MS20819-5J, AS5176J05	CRES	5/16-inch
-406	MS20819-6J, AS5176J06	CRES	3/8-inch
-408	MS20819-8J, AS5176J08	CRES	1/2-inch
-410	MS20819-10J, AS5176J10	CRES	5/8-inch

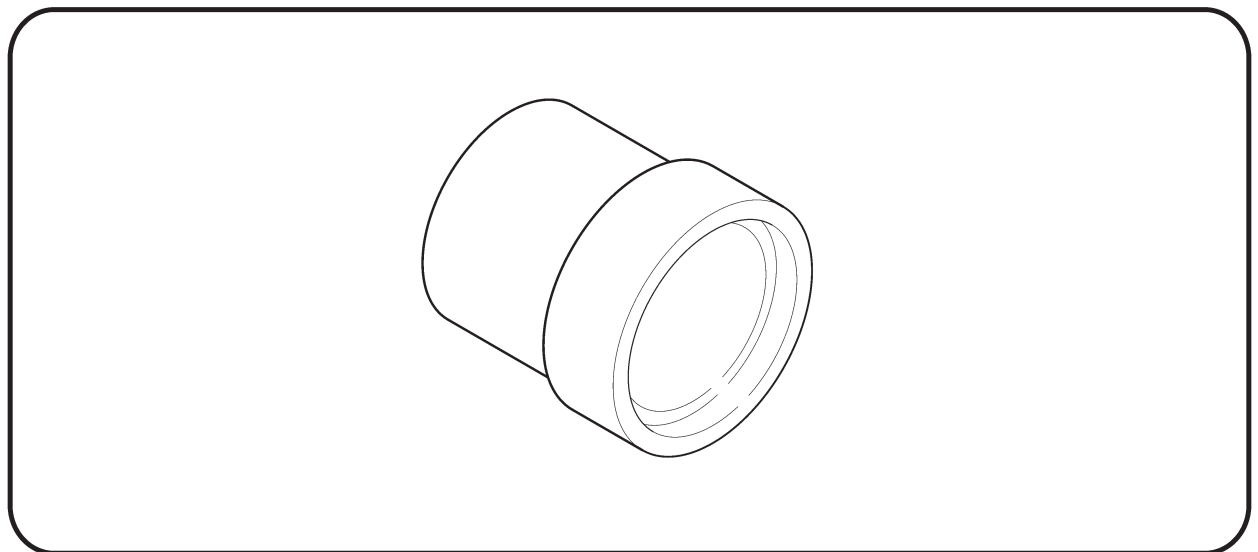

23-36 A880 Flared Tube Components (continued)

C. Adapters – NPT to Flare

Dash Numbers	Allowable Part Numbers	Material REF	Tube OD REF
-502	AN816-2D, AS5194D0202	AL	1/8-inch
-503	AN816-3D, AS5194D0302	AL	3/16-inch
-504	AN816-4D, AS5194D0402	AL	1/4-inch
-505	AN816-5D, AS5194D0502	AL	5/16-inch
-506	AN816-6D, AS5194D0604	AL	3/8-inch
-508	AN816-8D, AS5194D0806	AL	1/2-inch
-510	AN816-10D, AS5194D1008	AL	5/8-inch
-532	AN816-2J, AS5194J0202	CRES	1/8-inch
-533	AN816-3J, AS5194J0302	CRES	3/16-inch
-534	AN816-4J, AS5194J0402	CRES	1/4-inch
-535	AN816-5J, AS5194J0502	CRES	5/16-inch
-536	AN816-6J, AS5194J0604	CRES	3/8-inch
-538	AN816-8J, AS5194J0806	CRES	1/2-inch
-540	AN816-10J, AS5194J1008	CRES	5/8-inch
-562	AN816-2, AS5194-0202	STL	1/8-inch
-563	AN816-3, AS5194-0302	STL	3/16-inch
-564	AN816-4, AS5194-0402	STL	1/4-inch
-565	AN816-5, AS5194-0502	STL	5/16-inch
-566	AN816-6, AS5194-0604	STL	3/8-inch
-568	AN816-8, AS5194-0806	STL	1/2-inch
-570	AN816-10, AS5194-1008	STL	5/8-inch

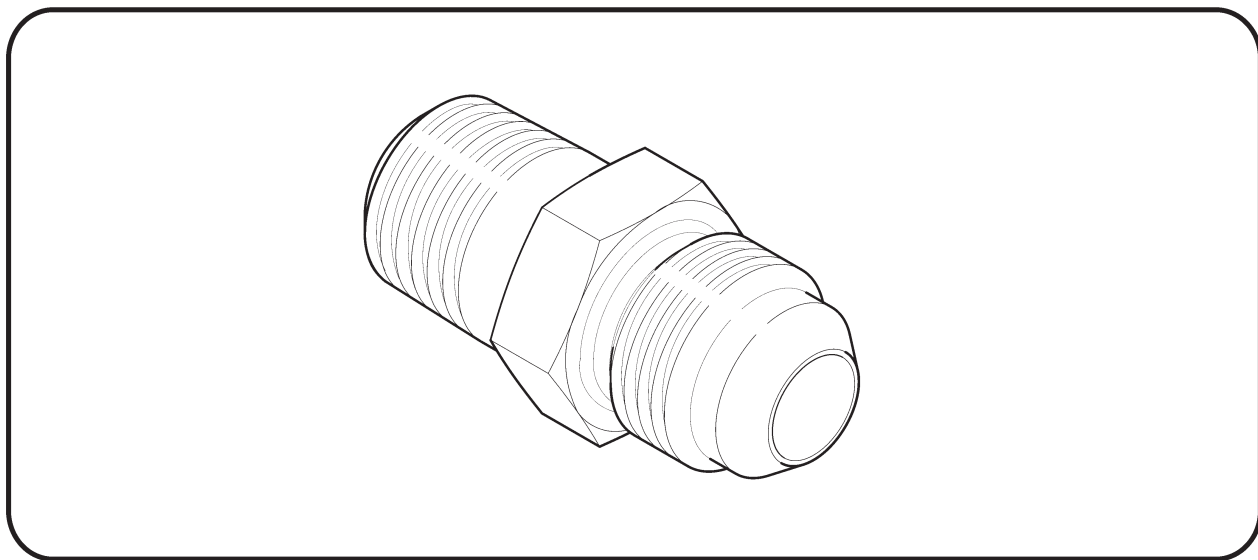

23-36 A880 Flared Tube Components (continued)

D. Elbows – 90°, NPT to Flare

Dash Numbers	Allowable Part Numbers	Material REF	Tube OD REF
-602	AN822-2D, MS20822-2D, AS5195W0202	AL	1/8-inch
-603	AN822-3D, MS20822-3D, AS5195W0302	AL	3/16-inch
-604	AN822-4D, MS20822-4D, AS5195W0402	AL	1/4-inch
-605	AN822-5D, MS20822-5D, AS5195W0502	AL	5/16-inch
-606	AN822-6D, MS20822-6D, AS5195W0604	AL	3/8-inch
-608	AN822-8D, MS20822-8D, AS5195W0806	AL	1/2-inch
-610	AN822-10D, MS20822-10D, AS5195W1008	AL	5/8-inch
-632	AN822-2J, MS20822-2J, AS5195J0202	CRES	1/8-inch
-633	AN822-3J, MS20822-3J, AS5195J0302	CRES	3/16-inch
-634	AN822-4J, MS20822-4J, AS5195J0402	CRES	1/4-inch
-635	AN822-5J, MS20822-5J, AS5195J0502	CRES	5/16-inch
-636	AN822-6J, MS20822-6J, AS5195J0604	CRES	3/8-inch
-638	AN822-8J, MS20822-8J, AS5195J0806	CRES	1/2-inch
-640	AN822-10J, MS20822-10J, AS5195J1008	CRES	5/8-inch
-662	AN822-2, MS20822-2, AS5195-0202	STL	1/8-inch
-663	AN822-3, MS20822-3, AS5195-0302	STL	3/16-inch
-664	AN822-4, MS20822-4, AS5195-0402	STL	1/4-inch
-665	AN822-5, MS20822-5, AS5195-0502	STL	5/16-inch
-666	AN822-6, MS20822-6, AS5195-0604	STL	3/8-inch
-668	AN822-8, MS20822-8, AS5195-0806	STL	1/2-inch
-670	AN822-10, MS20822-10, AS5195-1008	STL	5/8-inch

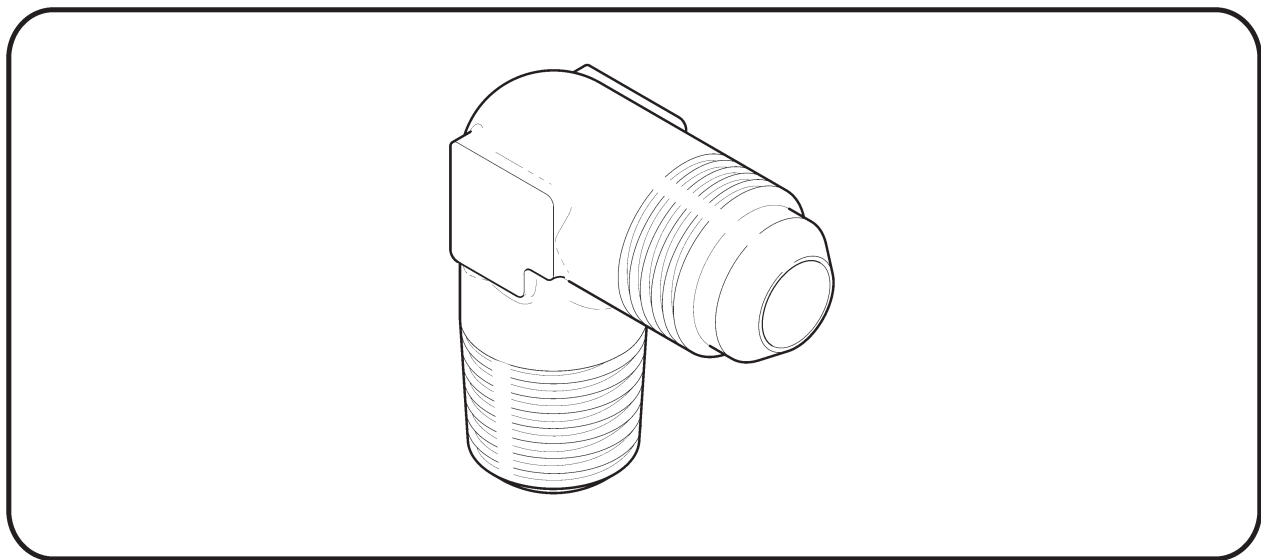

23-36 A880 Flared Tube Components (continued)

E. Elbows – 45°, NPT to Flare

Dash Numbers	Allowable Part Numbers	Material REF	Tube OD REF
-702	AN823-2D, MS20823-2D, AS5196W0202	AL	1/8-inch
-703	AN823-3D, MS20823-3D, AS5196W0302	AL	3/16-inch
-704	AN823-4D, MS20823-4D, AS5196W0402	AL	1/4-inch
-705	AN823-5D, MS20823-5D, AS5196W0502	AL	5/16-inch
-706	AN823-6D, MS20823-6D, AS5196W0604	AL	3/8-inch
-708	AN823-8D, MS20823-8D, AS5196W0806	AL	1/2-inch
-710	AN823-10D, MS20823-10D, AS5196W1008	AL	5/8-inch
-732	AN823-2J, MS20823-2J, AS5196J0202	CRES	1/8-inch
-733	AN823-3J, MS20823-3J, AS5196J0302	CRES	3/16-inch
-734	AN823-4J, MS20823-4J, AS5196J0402	CRES	1/4-inch
-735	AN823-5J, MS20823-5J, AS5196J0502	CRES	5/16-inch
-736	AN823-6J, MS20823-6J, AS5196J0604	CRES	3/8-inch
-738	AN823-8J, MS20823-8J, AS5196J0806	CRES	1/2-inch
-740	AN823-10J, MS20823-10J, AS5196J1008	CRES	5/8-inch
-762	AN823-2, MS20823-2, AS5196-0202	STL	1/8-inch
-763	AN823-3, MS20823-3, AS5196-0302	STL	3/16-inch
-764	AN823-4, MS20823-4, AS5196-0402	STL	1/4-inch
-765	AN823-5, MS20823-5, AS5196-0502	STL	5/16-inch
-766	AN823-6, MS20823-6, AS5196-0604	STL	3/8-inch
-768	AN823-8, MS20823-8, AS5196-0806	STL	1/2-inch
-770	AN823-10, MS20823-10, AS5196-1008	STL	5/8-inch

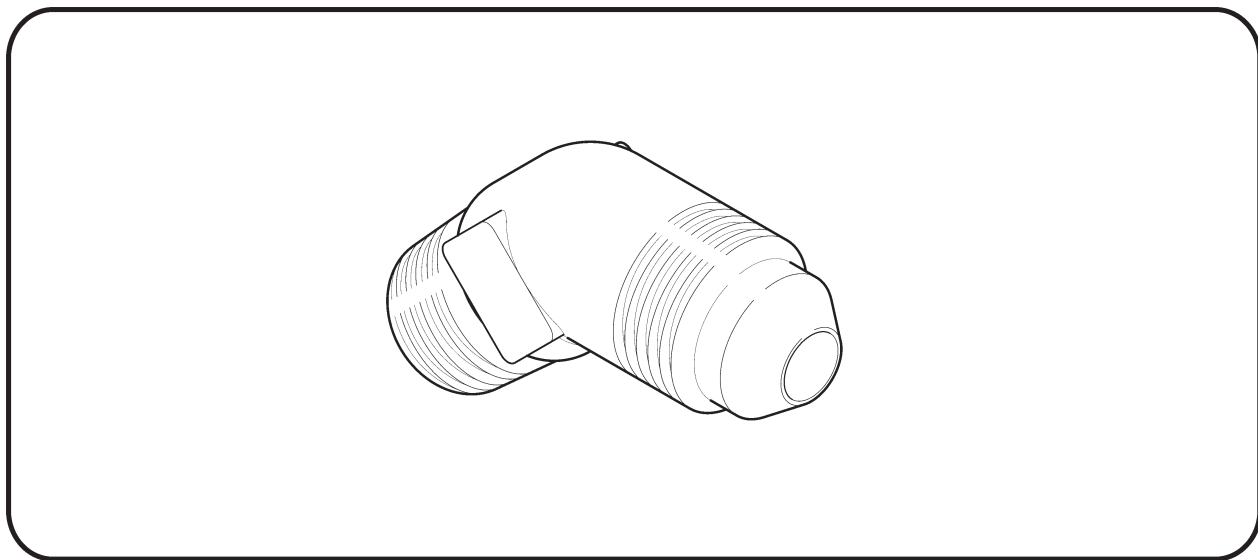

23-36 A880 Flared Tube Components (continued)

F. Elbows – 90°, Bulkhead Flare to Flare

Dash Numbers	Allowable Part Numbers	Material REF	Tube OD REF
-802	AN833-2D, AS1038D0202, AS1038W0202	AL	1/8-inch
-803	AN833-3D, AS1038D0303, AS1038W0303	AL	3/16-inch
-804	AN833-4D, AS1038D0404, AS1038W0404	AL	1/4-inch
-805	AN833-5D, AS1038D0505, AS1038W0505	AL	5/16-inch
-806	AN833-6D, AS1038D0606, AS1038W0606	AL	3/8-inch
-808	AN833-8D, AS1038D0808, AS1038W0808	AL	1/2-inch
-810	AN833-10D, AS1038D1010, AS1038W1010	AL	5/8-inch
-832	AN833-2J, AS1038J0202	CRES	1/8-inch
-833	AN833-3J, AS1038J0303	CRES	3/16-inch
-834	AN833-4J, AS1038J0404	CRES	1/4-inch
-835	AN833-5J, AS1038J0505	CRES	5/16-inch
-836	AN833-6J, AS1038J0606	CRES	3/8-inch
-838	AN833-8J, AS1038J0808	CRES	1/2-inch
-840	AN833-10J, AS1038J1010	CRES	5/8-inch
-862	AN833-2, AS1038-0202	STL	1/8-inch
-863	AN833-3, AS1038-0303	STL	3/16-inch
-864	AN833-4, AS1038-0404	STL	1/4-inch
-865	AN833-5, AS1038-0505	STL	5/16-inch
-866	AN833-6, AS1038-0606	STL	3/8-inch
-868	AN833-8, AS1038-0808	STL	1/2-inch
-870	AN833-10, AS1038-1010	STL	5/8-inch

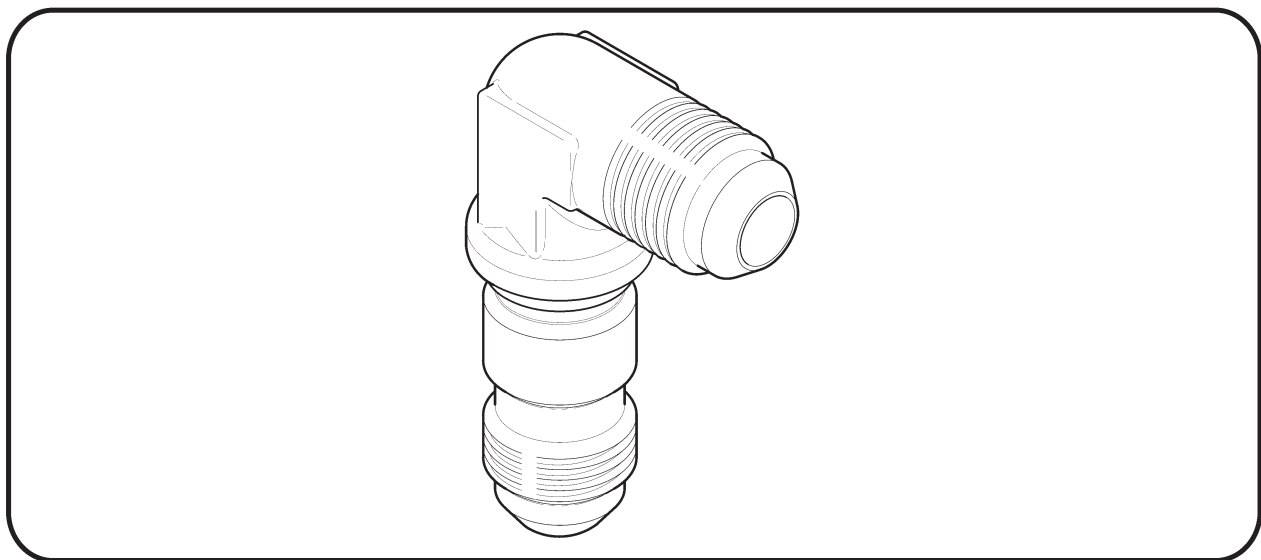

23-36 A880 Flared Tube Components (continued)

G. Unions – Flare to Flare

Dash Numbers	Allowable Part Numbers	Material REF	Tube OD REF
-902	AN815-2D, AS5174D0202, AS5174W0202	AL	1/8-inch
-903	AN815-3D, AS5174D0303, AS5174W0303	AL	3/16-inch
-904	AN815-4D, AS5174D0404, AS5174W0404	AL	1/4-inch
-905	AN815-5D, AS5174D0505, AS5174W0505	AL	5/16-inch
-906	AN815-6D, AS5174D0606, AS5174W0606	AL	3/8-inch
-908	AN815-8D, AS5174D0808, AS5174W0808	AL	1/2-inch
-910	AN815-10D, AS5174D1010, AS5174W1010	AL	5/8-inch
-932	AN815-2J, AS5174J0202	CRES	1/8-inch
-933	AN815-3J, AS5174J0303	CRES	3/16-inch
-934	AN815-4J, AS5174J0404	CRES	1/4-inch
-935	AN815-5J, AS5174J0505	CRES	5/16-inch
-936	AN815-6J, AS5174J0606	CRES	3/8-inch
-938	AN815-8J, AS5174J0808	CRES	1/2-inch
-940	AN815-10J, AS5174J1010	CRES	5/8-inch
-962	AN815-2, AS5174-0202	STL	1/8-inch
-963	AN815-3, AS5174-0303	STL	3/16-inch
-964	AN815-4, AS5174-0404	STL	1/4-inch
-965	AN815-5, AS5174-0505	STL	5/16-inch
-966	AN815-6, AS5174-0606	STL	3/8-inch
-968	AN815-8, AS5174-0808	STL	1/2-inch
-970	AN815-10, AS5174-1010	STL	5/8-inch

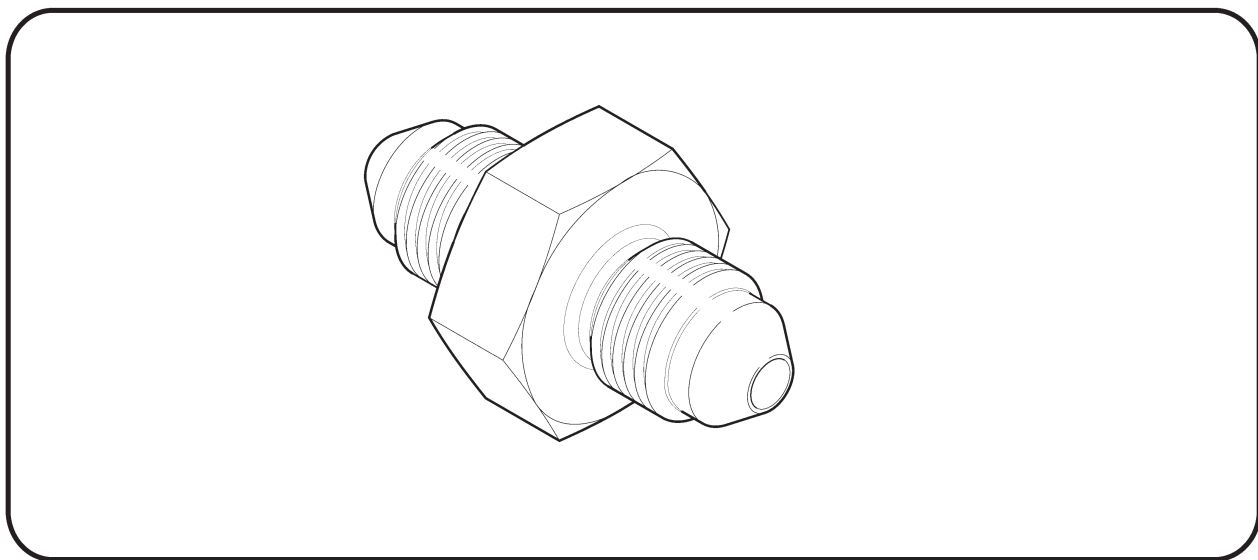

23-36 A880 Flared Tube Components (continued)

H. Nuts – Hex

Dash Numbers	Allowable Part Numbers	Material REF	Tube OD REF
-1002	AN924-2D, AN924-2W, AS5178W02	AL	1/8-inch
-1003	AN924-3D, AN924-3W, AS5178W03	AL	3/16-inch
-1004	AN924-4D, AN924-4W, AS5178W04	AL	1/4-inch
-1005	AN924-5D, AN924-5W, AS5178W05	AL	5/16-inch
-1006	AN924-6D, AN924-6W, AS5178W06	AL	3/8-inch
-1008	AN924-8D, AN924-8W, AS5178W08	AL	1/2-inch
-1010	AN924-10D, AN924-10W, AS5178W10	AL	5/8-inch
-1032	AN924-2J, AS5178J02	CRES	1/8-inch
-1033	AN924-3J, AS5178J03	CRES	3/16-inch
-1034	AN924-4J, AS5178J04	CRES	1/4-inch
-1035	AN924-5J, AS5178J05	CRES	5/16-inch
-1036	AN924-6J, AS5178J06	CRES	3/8-inch
-1038	AN924-8J, AS5178J08	CRES	1/2-inch
-1040	AN924-10J, AS5178J10	CRES	5/8-inch
-1062	AN924-2, AS5178-02	STL	1/8-inch
-1063	AN924-3, AS5178-03	STL	3/16-inch
-1064	AN924-4, AS5178-04	STL	1/4-inch
-1065	AN924-5, AS5178-05	STL	5/16-inch
-1066	AN924-6, AS5178-06	STL	3/8-inch
-1068	AN924-8, AS5178-08	STL	1/2-inch
-1070	AN924-10, AS5178-10	STL	5/8-inch

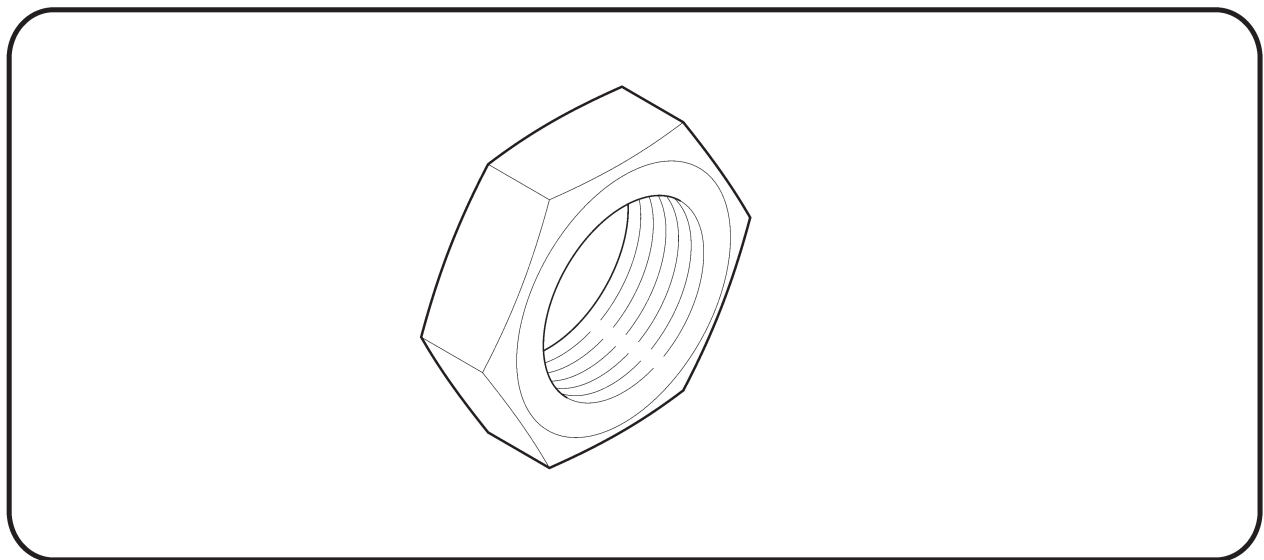

23-36 A880 Flared Tube Components (continued)

I. Tees – NPT to Flare

Dash Numbers	Allowable Part Numbers	Material REF	Tube OD REF
-1102	AN826-2D, MS20826-2D, AS5198W020202	AL	1/8-inch
-1103	AN826-3D, MS20826-3D, AS5198W030203	AL	3/16-inch
-1104	AN826-4D, MS20826-4D, AS5198W040204	AL	1/4-inch
-1105	AN826-5D, MS20826-5D, AS5198W050205	AL	5/16-inch
-1106	AN826-6D, MS20826-6D, AS5198W060406	AL	3/8-inch
-1108	AN826-8D, MS20826-8D, AS5198W080608	AL	1/2-inch
-1110	AN826-10D, MS20826-10D, AS5198W100810	AL	5/8-inch
-1132	AN826-2J, MS20826-2J, AS5198J020202	CRES	1/8-inch
-1133	AN826-3J, MS20826-3J, AS5198J030203	CRES	3/16-inch
-1134	AN826-4J, MS20826-4J, AS5198J040204	CRES	1/4-inch
-1135	AN826-5J, MS20826-5J, AS5198J050205	CRES	5/16-inch
-1136	AN826-6J, MS20826-6J, AS5198J060406	CRES	3/8-inch
-1138	AN826-8J, MS20826-8J, AS5198J080608	CRES	1/2-inch
-1140	AN826-10J, MS20826-10J, AS5198J100810	CRES	5/8-inch
-1162	AN826-2, MS20826-2, AS5198-020202	STL	1/8-inch
-1163	AN826-3, MS20826-3, AS5198-030203	STL	3/16-inch
-1164	AN826-4, MS20826-4, AS5198-040204	STL	1/4-inch
-1165	AN826-5, MS20826-5, AS5198-050205	STL	5/16-inch
-1166	AN826-6, MS20826-6, AS5198-060406	STL	3/8-inch
-1168	AN826-8, MS20826-8, AS5198-080608	STL	1/2-inch
-1170	AN826-10, MS20826-10, AS5198-100810	STL	5/8-inch

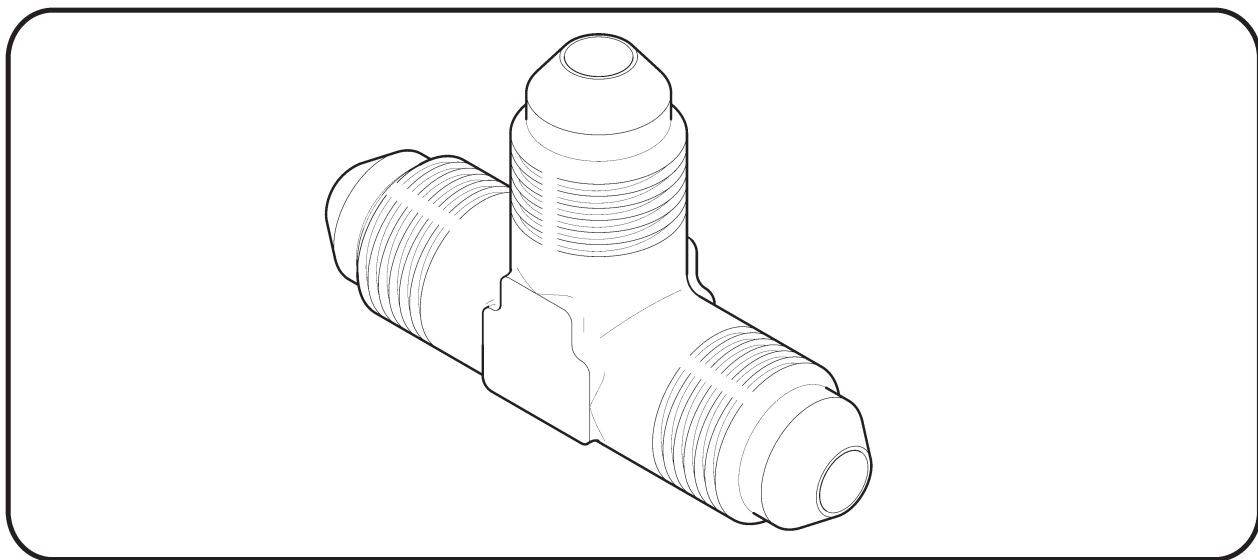

23-36 A880 Flared Tube Components (continued)

J. Plugs without Holes

Dash Numbers	Allowable Part Numbers	Material REF	Tube OD REF
-1202	AN814-2D, AN814-2W, AS5169D02, AS5169W02	AL	1/8-inch
-1203	AN814-3D, AN814-3W, AS5169D03, AS5169W03	AL	3/16-inch
-1204	AN814-4D, AN814-4W, AS5169D04, AS5169W04	AL	1/4-inch
-1205	AN814-5D, AN814-5W, AS5169D05, AS5169W05	AL	5/16-inch
-1206	AN814-6D, AN814-6W, AS5169D06, AS5169W06	AL	3/8-inch
-1208	AN814-8D, AN814-8W, AS5169D08, AS5169W08	AL	1/2-inch
-1210	AN814-10D, AN814-10W, AS5169D10, AS5169W10	AL	5/8-inch
-1232	AN814-2J, AS5169J02	CRES	1/8-inch
-1233	AN814-3J, AS5169J03	CRES	3/16-inch
-1234	AN814-4J, AS5169J04	CRES	1/4-inch
-1235	AN814-5J, AS5169J05	CRES	5/16-inch
-1236	AN814-6J, AS5169J06	CRES	3/8-inch
-1238	AN814-8J, AS5169J08	CRES	1/2-inch
-1240	AN814-10J, AS5169J10	CRES	5/8-inch
-1262	AN814-2, AS5169-02	STL	1/8-inch
-1263	AN814-3, AS5169-03	STL	3/16-inch
-1264	AN814-4, AS5169-04	STL	1/4-inch
-1265	AN814-5, AS5169-05	STL	5/16-inch
-1266	AN814-6, AS5169-06	STL	3/8-inch
-1268	AN814-8, AS5169-08	STL	1/2-inch
-1270	AN814-10, AS5169-10	STL	5/8-inch

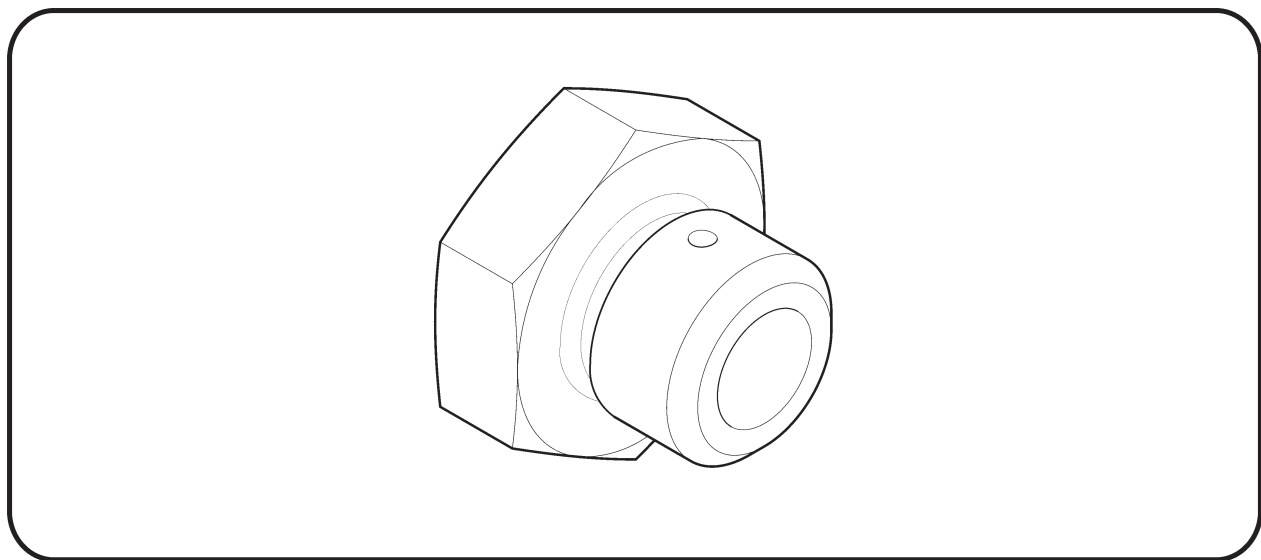

23-36 A880 Flared Tube Components (continued)

K. Plugs with Holes

Dash Numbers	Allowable Part Numbers	Material REF	Tube OD REF
-1302	AN814-2DL, AN814-2WL, AS5169D02L, AS5169W02L	AL	1/8-inch
-1303	AN814-3DL, AN814-3WL, AS5169D03L, AS5169W03L	AL	3/16-inch
-1304	AN814-4DL, AN814-4 WL, AS5169D04L, AS5169W04L	AL	1/4-inch
-1305	AN814-5DL, AN814-5WL, AS5169D05L, AS5169W05L	AL	5/16-inch
-1306	AN814-6DL, AN814-6WL, AS5169D06L, AS5169W06L	AL	3/8-inch
-1308	AN814-8DL, AN814-8WL, AS5169D08L, AS5169W08L	AL	1/2-inch
-1310	AN814-10DL, AN814-10WL, AS5169D10L, AS5169W10L	AL	5/8-inch
-1332	AN814-2JL, AS5169J02L	CRES	1/8-inch
-1333	AN814-3JL, AS5169J03L	CRES	3/16-inch
-1334	AN814-4JL, AS5169J04L	CRES	1/4-inch
-1335	AN814-5JL, AS5169J05L	CRES	5/16-inch
-1336	AN814-6JL, AS5169J06L	CRES	3/8-inch
-1338	AN814-8JL, AS5169J08L	CRES	1/2-inch
-1340	AN814-10JL, AS5169J10L	CRES	5/8-inch
-1362	AN814-2L, AS5169-02L	STL	1/8-inch
-1363	AN814-3L, AS5169-03L	STL	3/16-inch
-1364	AN814-4L, AS5169-04L	STL	1/4-inch
-1365	AN814-5L, AS5169-05L	STL	5/16-inch
-1366	AN814-6L, AS5169-06L	STL	3/8-inch
-1368	AN814-8L, AS5169-08L	STL	1/2-inch
-1370	AN814-10L, AS5169-10L	STL	5/8-inch

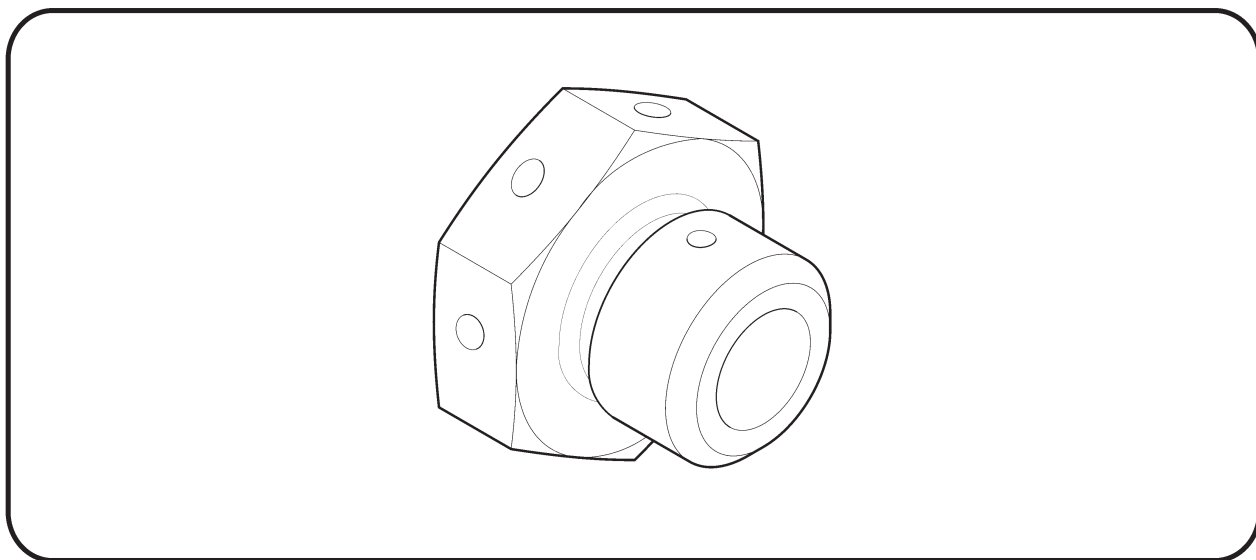

Intentionally Blank

23-40 Non-Destructive Testing

WARNING

Review appropriate Safety Data Sheet (SDS) when working in proximity to hazardous materials. Specific recommendations for use of personal protective equipment are located in the SDS.

23-41 Magnetic Particle Inspection

Ferromagnetic steel parts are inspected for structural defects using magnetic particle inspection. Steel parts covered by this specification are inspected per ASTM E1444 wet continuous process with ultra-violet light. Applicable requirements and limitations of the above standard apply.

Procedures and equipment used to perform the inspection shall conform to requirements of ASTM E1444. A magneto test penetrometer or a 30–60 gauss meter is used to verify the direction and effectiveness of all magnetic fields produced. Whenever possible, parts shall be inspected with both circular and longitudinal magnetization, but at least in two directions at right angles to each other. Minimum duration of application is $\frac{1}{2}$ second.

Pre- and post-solvent clean parts using PCBTF or similar solvent. Demagnetizing is accomplished using $AC \pm 3$ oersteds maximum. Verify part is demagnetized using a magnetic field strength indicator which does not exceed an absolute value above three gauss.

Area of part to be examined, position of part, directions of magnetization to be used and method of establishing the magnetization are presented within the inspection section of individual parts. Record the size and location of all rejectable indications.

A. Inspection Criteria

Parts (except gears) which are inspected by magnetic particle inspection shall be accepted or rejected according to the following criteria:

Acceptable indications:

- Indications smaller than 0.015 inch are not considered rateable.
- Indications caused by sharp changes in cross-section or part geometry.

Rejectable indications:

- Indications interpreted as cracks, seams, laps, shuts, or any flaws which are open to the surface.
- Indications oriented at an angle of more than 15 degrees from the longitudinal axis with length exceeding 0.125 inch.
- Circumferential indications on any shoulder or fillet (changes in diameter).
- Any indications which break over an edge, shoulder, fillet radius, keyway, spline, or an adjacent area of part more than 0.015 inch.
- Indications caused by undercuts at the toe of a weld.
- Indications caused by cracks in the weld or parent metal.
- Indications caused by inclusions in weld material exceeding 0.1 inch in length.

23-42 Fluorescent Penetrant Inspection

This specification provides for surface inspection of parts fabricated from nonmagnetic materials to detect discontinuities open to the surface, such as cracks, cold shuts, laps, porosity and other surface defects.

Applicable requirements and limitations of ASTM E1417 shall apply. After inspection is complete, solvent clean parts.

The step-by-step procedure and equipment used to perform the inspection shall be accomplished per ASTM E1417. The following types, methods, and sensitivity levels are recommended:

Type: 1–Fluorescent dye
Method: A–Water washable
Sensitivity: Level 2–Medium
Form: A–Dry powder

A. Inspection Criteria

Parts inspected by fluorescent penetrant method shall be accepted or rejected on basis of acceptance limits specified. If acceptance limits are not specified, rejectable surface defects and any of the following:

- Cracks
- Seams
- Cold shuts or laps
- Surface inclusions
- In castings, aligned discontinuous surface indications other than cracks, cold shuts and inclusions are rejectable if more than 3/8 inch in length.

23-50 Corrosion Control

23-51 Conversion Coat – Aluminum

Use the following procedures to prepare and apply conversion coat to aluminum alloys. Conversion coat improves corrosion resistance and adherence of paint and adhesives.

CAUTION

Do not allow Bonderite C-IC 33 Aero or M-CR 1201/1132 Aero to contact bonded joints.

A. Procedure

1. Unless otherwise specified, lightly scuff clean surface with 320-grit aluminum-oxide abrasive paper to remove corrosion or other contaminants.
2. Apply Bonderite C-IC 33 Aero to surface for 2–5 minutes. DO NOT allow Bonderite C-IC 33 Aero to dry; re-apply as required.
3. Rinse thoroughly with clean, potable water.

23-51 Conversion Coat – Aluminum (continued)**A. Procedure (continued)**

4. Apply Bonderite M-CR 1201 Aero to surface for 2–5 minutes (should be light golden brown). DO NOT allow Bonderite M-CR 1201 Aero to dry; re-apply as required.
5. Rinse thoroughly with clean, potable water. Gently wipe with clean & dry cloth, blow dry, or allow to air dry.

B. Felt Tip Applicator

Apply Bonderite M-CR 1132 Aero per manufacturer’s recommendations.

23-60 Priming and Painting

This specification outlines preparation and application requirements for primers and topcoat. Primers provide corrosion protection and a final finish or a base for topcoat. Approved materials are listed in § 23-70.

Unless directed, do not prime or paint the following:

- Sliding friction joints.
- Stainless steel parts.
- Swivel joints and adjustable rod ends.
- Plastic, rubber, electrical components and wires or similar materials.
- Bolted joints where torque is a specific requirement for clamping action.
- Bearing press-fit, or close tolerance slip-fit, joints (except where wet primer is part of the assembly procedure).

WARNING

Review appropriate Safety Data Sheet (SDS) when working in proximity to hazardous materials. Specific recommendations for use of personal protective equipment are located in the SDS.

A. Priming

1. Preparing Aluminum (for Steel parts see step 2)

Unless otherwise specified, conversion coating per § 23-51 is standard treatment before priming aluminum. If bare aluminum is primed without conversion coating, the following procedure must be used:

- a. Alkaline clean if immersion is practical, otherwise wipe clean with an approved degreasing agent. Do not allow alkaline cleaner to contact bonded joints.
- b. Lightly scuff the surface with Scotch-Brite pads.
- c. Wipe with a tack rag to remove any foreign material or damp wipe with an approved solvent.
- d. Air dry. Do not touch parts with bare hands until primed.

23-60 Priming and Painting (continued)**A. Priming (continued)**

2. Preparing Steel (for Aluminum see step 1)

Alkaline clean is the preferred method for cleaning stainless steel. Alternately, stainless steel may be cleaned using an approved solvent. Do not allow alkaline cleaner to contact bonded joints.

Steel parts should only be cleaned using an approved solvent; using an alkaline cleaning process on steel may cause a corrosive reaction.

Where immersion is not practical or for extremely greasy or dirty parts, a preclean in a solvent vapor degreaser may be used.

Air or blow dry using filtered, dry, compressed air.

3. Application

Apply primer after mixing per manufacturer's recommendations. Primer coating is not to exceed 0.0005–0.0020 inch thickness per coat. For parts with internal openings, such as tubes, prime the inside as follows:

- a. Thin primer to watery consistency using required reducer.
- b. Pour in primer, slosh around, then drain immediately.
- c. Dry parts at least (6) hours before using.

4. Inspection

Inspect for complete coverage and excessive thickness. If primer is excessively thick, strip part and re-prime. Refer to § 23-70 for approved materials.

NOTE

Primed areas that have been sanded to bare metal must have conversion coating (if required) and primer re-applied prior to topcoat to restore anti-corrosion properties.

B. Painting Topcoat

Prior to liquid topcoat application, ensure surfaces have been cleaned and primed. In general, most parts will be cleaned and primed as detail parts. However, in some cases, such as the gearbox assembly, this is not practical and primer and topcoat are applied on the assembled component.

Previously primed surfaces, or primed surfaces that have completely cured require the following preparation before paint:

1. Lightly sand using 220-grit or finer aluminum-oxide abrasive paper.
2. Lightly scuff with Scotch Brite pads (optional).
3. Wipe with clean cloth and approved solvent.
4. Wipe with tack cloth.
5. Apply topcoat.

Intentionally Blank

23-70 Approved Materials

The following items are available from the noted manufacturer(s) or their distributor(s). Check with appropriate regulatory authority(s) for allowable usage of materials.

WARNING

Review appropriate Safety Data Sheet (SDS) when working in proximity to hazardous materials. Specific recommendations for use of personal protective equipment are located in the SDS.

CAUTION

Follow product manufacturer’s instructions for handling and storage.

23-71 Paint Strippers

CAUTION

Use of non-approved liquid-strippers may lead to part failure.

PRODUCT	MANUFACTURER/SUPPLIER	APPLICATION
Cee-Bee Stripper A-292NC-M	McGean-Rohco: Cee-Bee Division. Downey, CA. https://Cee-Bee.com	Metal parts, except blades and flex plates. Do not use near mechanically fastened or bonded joints.
Plastic Media Blasting System, AMMO 301 size 20/30, type II (or equivalent polymer media)	Pauli Systems Inc. Fairfield, CA	Metal parts except blades and unsupported sheet metal less than 0.040 inch thick. Blast pressure for steel frames: 40–55 PSI Blast pressure for aluminum parts: 30–40 PSI

23-72 Solvents and Cleaners

PRODUCT	MANUFACTURER/SUPPLIER	APPLICATION
QSOL 220	Safety-Kleen Systems, Inc. Plano, TX	General use and for cleaning prior to applying primer, topcoat, adhesive, or sealant.
Benzene, 1-Chloro-4 (Trifluoromethyl) PCBTF***	Any	
Acetone***	Any	
220 Low VOC Cleaner	Axalta, Wilmington, DE	
Final Klean 3909S	Du Pont Chemical Los Angeles, CA	
XP Aerospace Prep Surface Cleaner	AkzoNobel, Waukegan, IL	
EM-Citro*	LPS Laboratories, Inc. Tucker, GA	Removing adhesive residue on cabin and polycarbonate & acrylic windshield.
Lacolene (Aliphatic Hydrocarbon)	Any	Windshield and plastic cleaning and general residue removal.
Plexus®	B.T.I. Chemical Co. Oak Park, CA	

23-72 Solvents and Cleaners (continued)

PRODUCT	MANUFACTURER/SUPPLIER	APPLICATION
Presolve	LPS Laboratories, Inc. Tucker, GA	Hydraulic components only.
Tetrachloroethylene (Perchloroethylene)	Any	Vapor degreaser.
815 GD	Brulin Corporation Indianapolis, IN	Ultrasonic cleaning, general use. **
SF50	L&R Mfg. Co. Kearny, NJ	
#112 Ammoniated or #222 Nonammoniated cleaning solution	L&R Mfg. Co. Kearny, NJ	Ultrasonic cleaning, avionics components only.
#194 rinse solution		
Cleanup Wipe E-4365	Sontara Candler, NC	Cleaning and drying.
Snoop Liquid Leak Detector	Swagelok Salon, OH	Leak detector.

* May be used on acrylic plastic.

** Mix 5%–20% by volume; titration not required.

*** Acetone and PCBTF may be mixed 50-50.

23-73 Fillers and Putty

PRODUCT	MANUFACTURER/SUPPLIER	APPLICATION
05960 Glazing Putty 05860 Dry Guide Coat 31180 Finishing Glaze	3M St. Paul, MN	Minor surface imperfections.
SBF1191 Filler	Gearhead Products Indianapolis, IN	
FE-351 Cream Hardener	Catalyst Systems Gnadenhutten, OH	

23-74 Torque Seal

PRODUCT	MANUFACTURER/SUPPLIER	APPLICATION
83314 thru 83321 Except 83316 (red)	Dykem Cross-Check ITW Pro Brands	Torque seal.

23-75 Primers

A. Non-chromate Primers

	Corlar 13580S*	Desoprime CA7502*	Desoprime CA7422*
Manufacturer	Axalta	PPG	PPG
Base	Corlar 13580S Epoxy Primer	CA7502A	CA7422A
Activator	Corlar 13180S Epoxy Activator	CA7502B	CA7422B
Reducer	13756S VOC-Exempt Reducer	CA7502C	CA7422C
Base: Activator: Reducer	4:1:1	4:4:1	4:4:1
Viscosity	17-21 sec in Zahn #2	15-19 sec in Zahn #2	15-19 sec in Zahn #2
Induction time	30 minutes	2 hours at 55–70°F 1 hour at 71–80°F 30 minutes > 70°F	2 hours at 55–68°F 1 hour at 69–95°F
Pot life	8 hours at 70°F	4 hours at 70°F	4 hours at 70°F
Flash off time	None	30 minutes	30 minutes
Dry time	2 hours at 70°F 1 hour at 130°F	3 hours at 70°F 30 minutes at 120°F	3 hours at 70°F 30 minutes at 120°F
Recoat window	48 hours	48 hours	48 hours

* Shelf life per manufacturer's recommendation.

B. Chromate Primers

	44GN007*	10P20-44*
Manufacturer	PPG	AkzoNobel
Base	44GN007	10P20-44
Activator	44GN007CAT	EC-265 or EC-273
Reducer	Distilled or deionized water	TR-114 or TR-102
Base: Activator: Reducer	3:1:8	3:1:1
Viscosity	18–22 seconds in Zahn #2	13–19 seconds in Zahn #2
Induction time	None	None
Pot life	4 hours at 70°F	4 hours at 77°F
Flash off time	15 minutes	30 minutes
Dry time	2 hours at 70°F 45 minutes at 120°F	30 minutes at 140°F
Recoat window	24 hours	24 hours

* Shelf life per manufacturer's recommendation.

23-76 Powder Coat

PRODUCT	MANUFACTURER
Interpon 100-AL101QF Gray Zinc Rich Epoxy Powder*	AkzoNobel Santa Fe Springs, CA
81-2158 Vitralon Gray Zinc Rich Epoxy Powder*	Pratt & Lambert Chemical Coatings Buffalo, NY
39/80020 Smooth Matte Black Polyester Topcoat Powder*	Tiger Drylac USA Cucamonga, CA
49/72460 Smooth Glossy Gray RAL 7043 Polyester Topcoat Powder*	" "
49/22460 Smooth Glossy Yellow RAL 1028 Polyester Topcoat Powder*	" "
PFWF104S9 White Polyester Topcoat Powder*	Dupont Co. Wilmington, DE

* Shelf life is 12 months from date of manufacture at ambient temperature.

Intentionally Blank

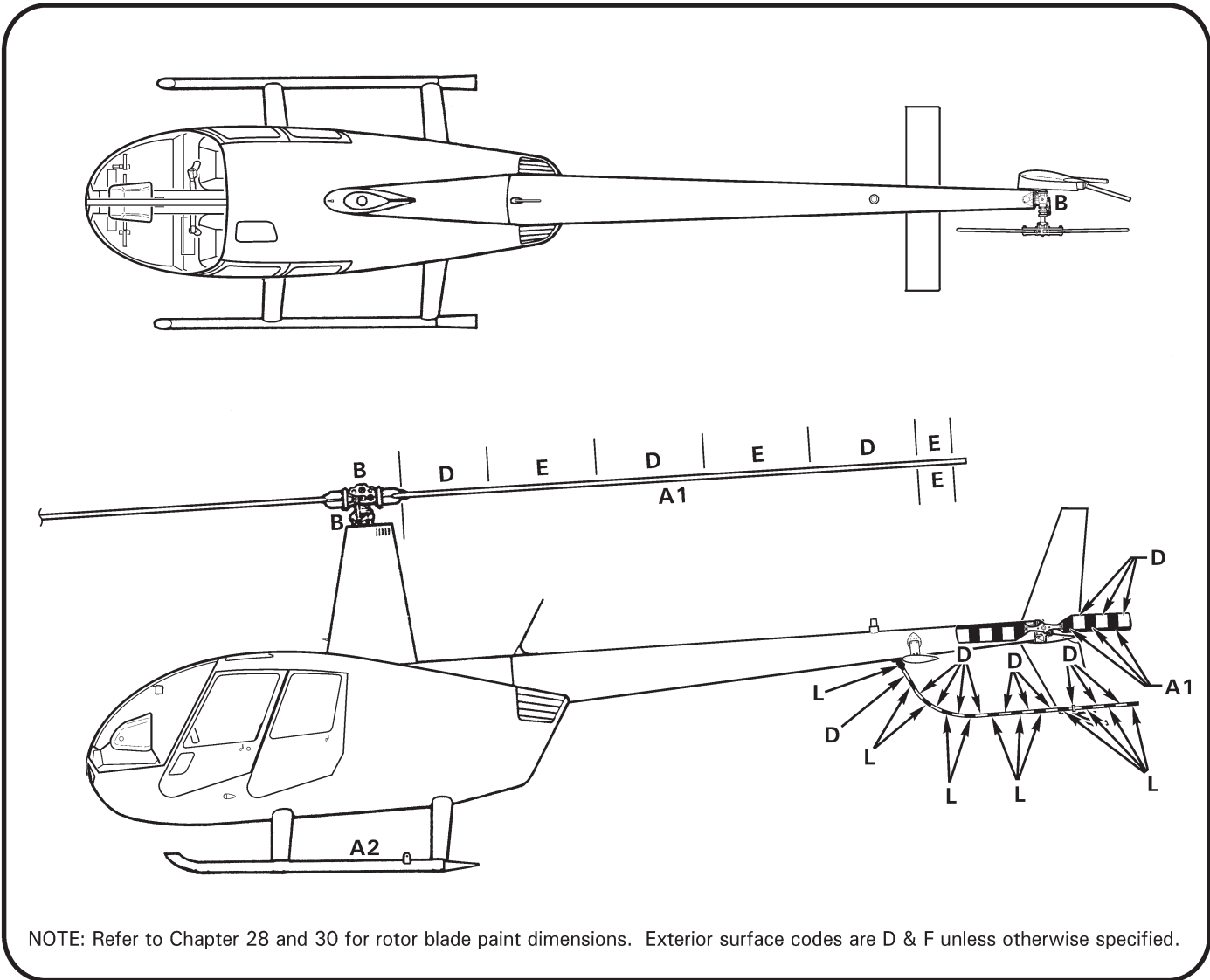

FIGURE 23-3 PAINT CODES

23-77 Paints

Refer to Figures 23-3 & 23-4 for paint code application. Paint codes for specific helicopter serial numbers are listed on the inside cover of Airframe Maintenance Record (logbook).

FINISH CODE	MATERIAL*	ADDITIVES	MANUFACTURER	RHC PART NO.	APPLICATION
A1	Flat Black 18BK006	18BK006CAT Catalyst	PPG Aerospace; Irvine, CA	18BK006	Blade black
	Abrasion Resistant 23T3-90 Black	PC-216 Curing Solution	AkzoNobel; Waukegan, IL	23T3-90	
A2	FR2-55 Mat Topcoat	Thinner: water	Mapaero; Pamiers, France	557Z7038B005K	Interior, skid tube, windshield and window trim black
	Aerofine 8250 Topcoat	Thinner: water	AkzoNobel; Waukegan, IL	A8250/F9007	

23-77 Paints (continued)

FINISH CODE	MATERIAL *	ADDITIVES	MANUFACTURER	RHC PART NO.	APPLICATION
A3	Cardinal A-2000 Flat Black		Cardinal; Cleveland, OH	A-2000-BKE30903	Interior, skid tube, windshield and window trim touch up (Aerosol)
	Krylon 1613 Semi-Flat Black		Krylon; Columbus, OH	1613	
B	Dark Gray Imron AF400/AF700	13100S Activator 13110S Activator	Axalta; Wilmington, DE	DS020EP	Dark grey
C	Engine Gray IE-8948		Randolph, Chicopee, MA	IE-8948	Engine Enamel
	Lycoming Gray G-5436		Randolph, Riverside, CA	G-5436	
	Lycoming A219		Randolph, Cleveland, OH	A219	
D	White Imron AF400/AF700	13100S Activator 13110S Activator	Axalta; Wilmington, DE	N0774EP	White
E	Yellow Imron AF400/AF700	13100S Activator 13110S Activator	Axalta; Wilmington, DE	N0680EP	Yellow
F	Imron AF400/AF700 Colors	13100S Activator 13110S Activator	Axalta; Wilmington, DE	Refer to Airframe Maintenance Record	Exterior
G	Clear Imron AF740	13100S Activator 13110S Activator 13930S Reducer	Axalta; Wilmington, DE	AF740	Clear coat
	1311 Matte Clear Coat		Krylon; Columbus, OH	1311	Clear coat aerosol
J	White Imron 2.1 FT	9T00-A Activator D-121 Tint D-101 Tint 2100-P 2.1 Binder 9T20 Flattenner	Axalta; Wilmington, DE	9T00-A D121 D101 2100P 9T20	Floats, fixed utility (do NOT paint pop-out floats)
K	Printcolor White Ink 750-9005 Printcolor Black Ink 750-8005 Printcolor Maize Yellow Ink 750-1205 Printcolor Carnation Red 750-3005	Printcolor Glass Hardener 700 Gensolve Thinner GS-017 Slow Retarder 10-03432	Deco; Orange, CA	7509005 7508005 7501205 7503005	Silkscreen
L	Red Imron AF400/AF700	13100S Activator 13110S Activator	Axalta; Wilmington, DE	N0759EP	Red
Q	ProtectaClear		Everbrite; Rancho Cordova, CA	Protecta	Optional on bare area of main rotor spar, refer to R44 SL-79

* Shelf life per manufacturer's recommendation.

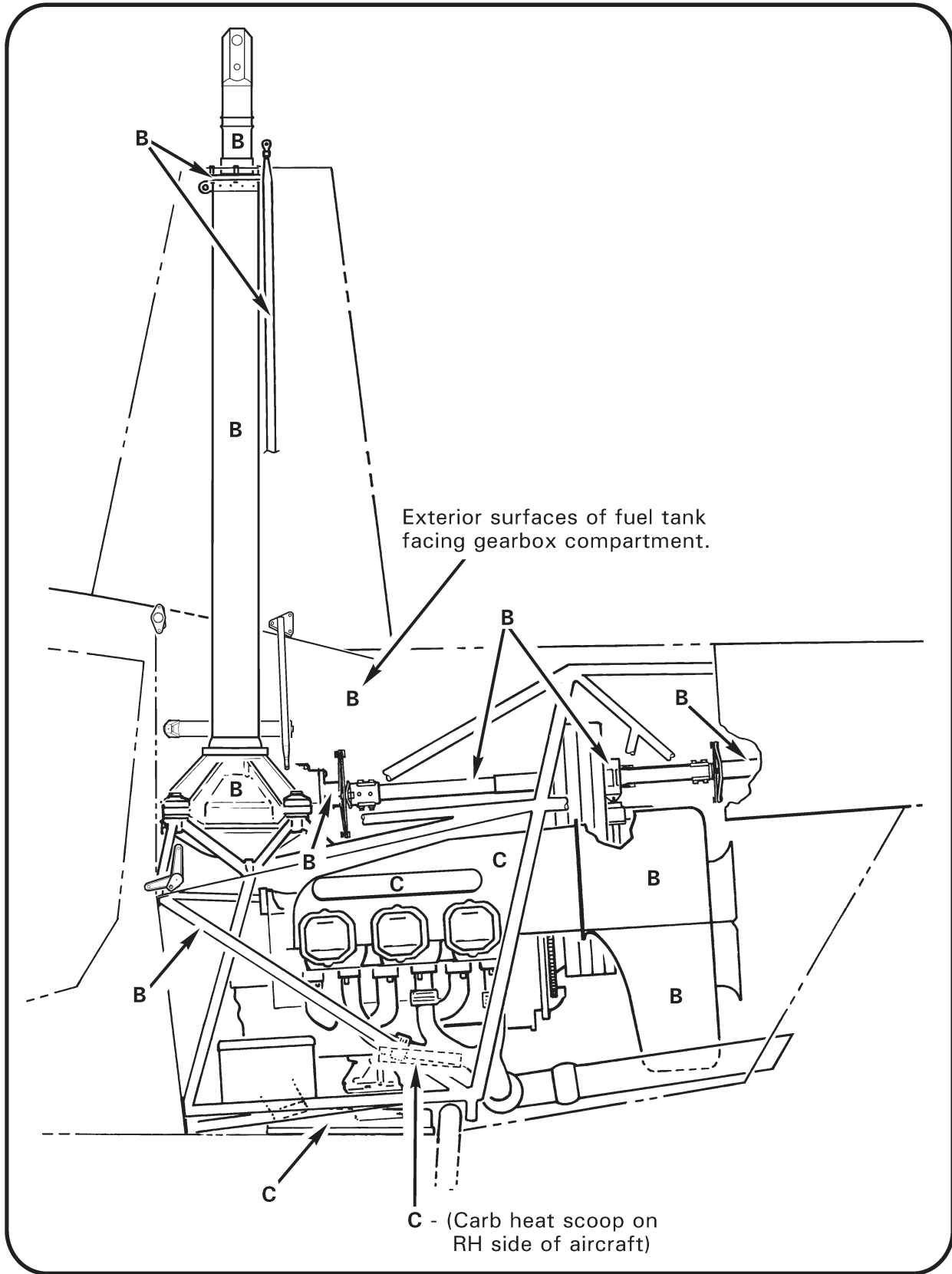

FIGURE 23-4 PAINT CODES

23-78 Lubricants

RHC PART NO.	LUBRICANT TYPE	MANUFACTURER'S PART NO.	MANUFACTURER
A257-1	Grease (general purpose)	101	Southwestern Petroleum Corp.; Fort Worth, TX
A257-2	Gear oil	201 SAE 90	Southwestern Petroleum Corp.; Fort Worth, TX
A257-3	Grease	Aero Shell 14 MIL-G-25537	Shell Oil Co.
A257-4	Oil (automatic transmission fluid)	Dexron II or Dexron II/Mercon or Dexron III/Mercon or Dex/Merc	Any
A257-6	Grease (fuel resistant)	Fuelube EZ Turn	Fleet Supplies Inc. Cleveland, OH United-Erie Div. of Interstate Chemical Co.; Erie, PA
A257-7	Dry film lubricant	Lubri-Kote Type A 1040 CR	Mealey Ind. Lubricants Cleveland, OH
A257-8	Rubber lubricant	P-80	International Products Corp. Trenton, NJ
A257-9	Anti-seize	Silver Grade	Loctite Corp. Newington, CT
A257-10	Substitute A257-16		
A257-12	Grease	MobilGrease 28 MIL-PRF-81322	Exxon Mobil Corp., Fairfax, VA
A257-15	Hydraulic fluid	Per MIL-PRF-5606	Any
A257-16	Engine Oil Approved for 0–90° F ambient). Substitute A257-24 as required.	SAE 20W-50, SAE J1966	Any
A257-17	Substitute A257-19		
A257-18	O-ring lubricant	55	Dow Corning Corp. Midland, MI
A257-19	Valve lubricant and sealant compound	111	Dow Corning Corp. Midland, MI
A257-20	Pag oil	34015050-95800C020 (Nissan Type R)	Idemitsu Lubricants America Southfield, MI
A257-21	Petrolatum lubricant	P-16	Panef Corp. Milwaukee, WI
A257-22	Gear oil, synthetic	Mobil SHC 629	Exxon Mobil Corp., Fairfax, VA
A257-24	Engine oil (Approved for > 60°F ambient)	SAE 50, SAE J1966	Any

23-79 Adhesives and Sealants

RHC PART NO.	DESCRIPTION	COLOR	MFR. PART NO.	MANUFACTURER
B270-1	Sealant – manganese-cured, fuel resistant (2-part)	Gray	AC-730 B-*	3M Co. St. Paul, MN
B270-2	Substitute B270-1			
B270-4	Substitute B270-13			
B270-5	Sealant – synthetic rubber putty (1-part)	White Light Gray	Q4-2805 94-031	Dow Corning Corp. Midland, MI
B270-6	Sealant – thread, anaerobic (1-part)	White	56521 (50 ml tube) 56525 (250 ml tube)	Permatex, Inc. Solon, OH
	Sealant & lubricant – thread (1-part)	Gray	Titeseal 55	Radiator Spec. Co. Charlotte, NC
B270-7	Substitute B270-14			
B270-8	Adhesive – rubber, nitrile/acetone (1-part)	Tan	C 160	Stabond Corp. Gardena, CA
			Fast Tack 1000NF	3M Co. St. Paul, MN
B270-9	Adhesive – epoxy, structural, flexible (2-part)	Gray	2216 B/A	3M Co. St. Paul, MN
B270-10	Adhesive/sealant – threadlocker, anaerobic, tight-fits (1-part)	Red	271	Henkel Loctite Corp. Rocky Hill, CT
B270-11	Adhesive/sealant – threadlocker, anaerobic, loose-fits (1-part)	Red	277	Henkel Loctite Corp. Rocky Hill, CT
B270-12	Sealant – electrical potting (1-part epoxy)	Gray	50-3122RGR15 (1-qt can) 50-3122RGR33 (syringe)	Epoxies Etc. Cranston, RI
B270-13	Sealant – silicone rubber, noncorrosive (1-part)	Translucent	3145	Dow Corning Corp. Midland, MI
			19-155	Zoro US Buffalo, IL
B270-14	Substitute B270-8			
B270-15	Adhesive – plastic, for vinyl (1-part)	Clear	2262	3M Co. St. Paul, MN
B270-16	Substitute B270-14			
B270-17	Adhesive – cyanoacrylate, instant (1-part)	Clear	Super Bonder 495	Henkel Loctite Corp. Rocky Hill, CT
B270-18	Substitute B270-1			
B270-19	Adhesive – epoxy structural, rigid (2-part)	Green	1838 B/A	3M Co. St. Paul, MN

23-79 Adhesives and Sealants (continued)

RHC PART NO.	DESCRIPTION	COLOR	MFR. PART NO.	MANUFACTURER
B270-20	Adhesive/sealant – threadlocker, anaerobic, non-permanent (1-part)	Purple	222 or 222MS	Henkel Loctite Corp. Rocky Hill, CT
B270-21	Protectant – corrosion (1-part)	Amber	Max Wax	Corrosion Technologies Corp. Garland, TX
	Protectant – corrosion, non-drying (1-part)	Lt. Amber	LPS 3	LPS Laboratories, Inc. Tucker, GA
B270-22	Substitute B270-21			
	Protectant – corrosion, drying (1-part)	Amber	LPS Hardcoat	LPS Laboratories, Inc. Tucker, GA
B270-23	Sealant – gasket (1-part)	Purple	515	Henkel Loctite Corp. Rocky Hill, CT
B270-24	Activator/primer – anaerobic (1-part); (for optional use with B270-10, -11, & -20)	Translucent Green	7649	Henkel Loctite Corp. Rocky Hill, CT
B270-25	Clear coat – automotive touch up, brush in bottle (1-part)	Clear	Clear Coat Touch up Bottle	Automotive Touchup Harahan, LA
B270-26	Sealant – polysulfide, window glazing (2-part)	Black	AC-251 B-1	3M Co. St. Paul, MN
B270-27	Adhesive – epoxy, high strength structural, flexible (2-part)	Translucent Red Blue	EA 9309NA EA 9309.2NA	Henkel Loctite Corp. Rocky Hill, CT
B270-28	Substitute B270-27			
B270-29	Activator – anaerobic (1-part); (for optional use with B270-6)	Green	24163 (6 oz aerosol can)	Permatex, Inc. Solon, OH

* Dash number for minimum hours application life may be -½, -2, -6, or -12.

23-80 Miscellaneous Practices

23-81 Part Interchangeability

Refer to R44 Illustrated Parts Catalog for part interchangeability information.

23-82 Thermal Fitting Parts

General Procedures for using heat to fit parts during assembly or evaluating parts that may have been overheated in service:

Aluminum parts must not be heated above 200° F for more than 5 minutes. Higher temperatures or longer times adversely affect strength and corrosion properties. Scrap any aluminum parts suspected of going above 325° F regardless of time at temperature.

Steel parts (bare) – Maximum temperature 300° F. Higher temperature can reduce the strength or cause temper brittleness in some alloys.

Steel parts (cadmium plated) – Maximum temperature 300° F. Higher temperatures will melt the plating and adversely affect steel strength by a process called liquid metal embrittlement.

Bearings and carburized parts such as gears, clutch shafts, and clutch housings should not be heated above 300° F. Higher temperatures will reduce the surface hardness and increase wear rates.

Always heat parts in an oven with temperature control set no greater than the maximum temperature allowed for the part.

Always attach a pyrometer and thermocouple to the smallest aluminum part in the oven. Never depend on the oven control to determine part temperature.

Cooling a part for thermal fitting at assembly is not recommended. Water vapor from the air will condense on the part and frequently introduce water into the assembly causing severe internal corrosion over time.

23-83 Replacement Component Identification (Data) Plates

In order to issue a replacement component identification plate for field installation, RHC must first receive the old identification plate in legible condition. If old identification plate is lost or destroyed, then RHC must have an original letter (photocopies or faxes are NOT acceptable) from customer’s Civil Aviation Authority (sent via postal mail, or via electronic mail directly from authority domain, such as “faa.gov”) authorizing identification plate replacement AND stating component name, part number, and serial number for each requested identification plate. There is a charge for each plate issued.

Identification plates may be carefully removed using a sharp plastic scraper. If necessary, use a heat gun to soften plate adhesive. Retain in a dry, contaminate-free area until ready for reinstallation.

Damp wipe local area with acetone or equivalent solvent prior to reinstallation. Residual adhesive on identification plate is usually sufficient for good adhesion. If necessary, use B270-9 adhesive or equivalent to secure.

23-84 Crimp Inspection

Refer to Figure 23-5.

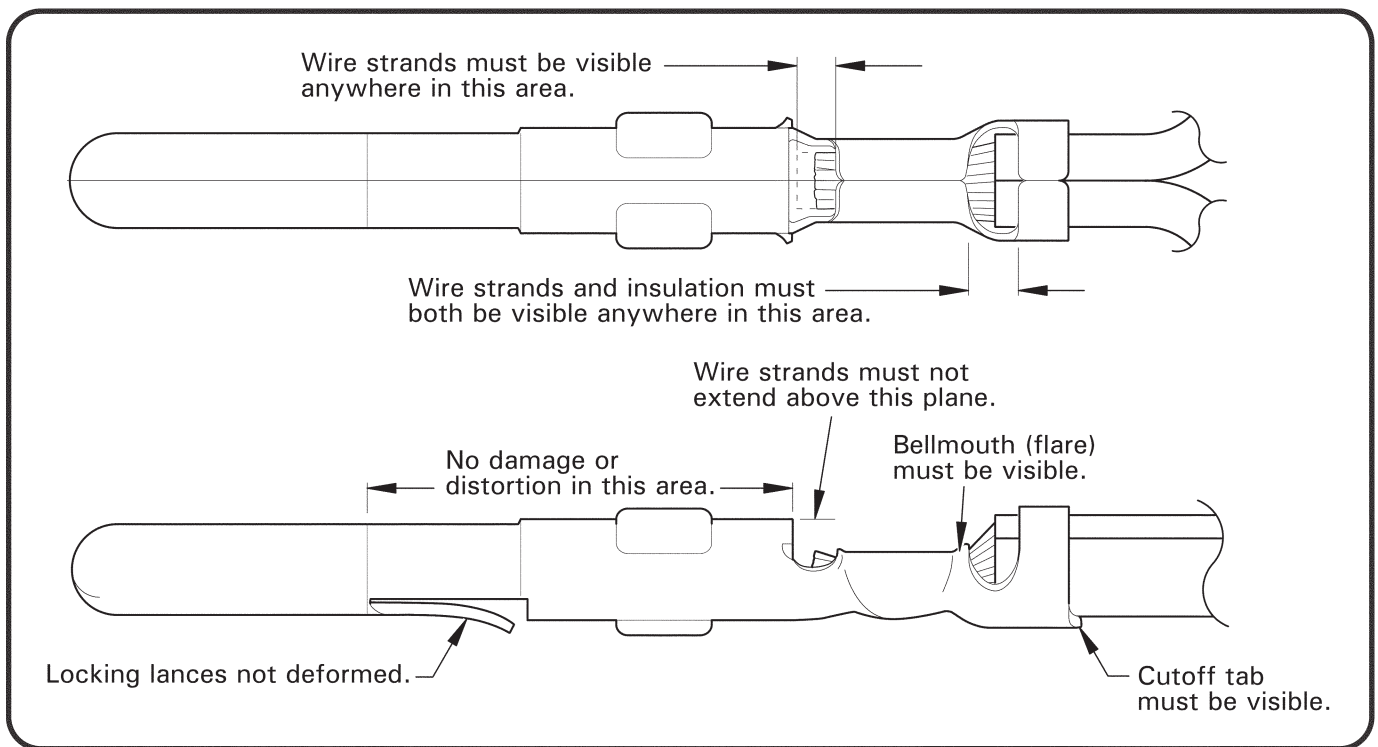

FIGURE 23-5 CRIMP INSPECTION

23-85 Storage Limits

1. B283 hoses have a shelf storage life of 5 years. Hose service life is “on condition”, with a maximum of 12 years.
2. Elastic cords have a shelf storage life of 5 years. Elastic cord service life is “on condition”, with a maximum of 12 years. Use invoice or FAA Form 8130 date as start date.
3. Store V-belts at less than 85°F (30°C), with relative humidity below 70%. Avoid solvent and oil vapors, atmospheric contaminants, sunlight, and ozone sources (electric motors, arc welding, ionizing air purifiers, etc.). Belt shelf life is 4 years if preceding recommendations are followed. Use invoice date or FAA Form 8130 date as start date.
4. Oils and greases have a 5 year shelf life when stored and kept sealed in their original container. Use invoice date or FAA Form 8130 date as start date unless the manufacturer has marked container with manufacture date (in which case use manufacture date as start date).
5. Rubber O-rings, seals, and gaskets have a twenty (20) quarter, five (5) year shelf life from the indicated cure date. Fluorocarbon (Viton) and silicon rubber products shall adhere to manufacturer’s expiration date(s). Service life is “on condition” with a maximum of 12 years.
6. Store uninstalled fuel bladder in original container (if available) at 70°F to 80°F and below 70% humidity. Coat bladder with clean, non-detergent engine mineral oil to prevent rubber from drying out and cracking. Store bladder in relaxed condition free from tension, compression, or other deformation such as creases or folds.

23-86 B526 Screws and B527-08 Washers

| B526 (TORX Plus®) Screws and B527-08 Washers information has been moved to § 16-61.

CHAPTER 24**AUTOPILOT**

<u>Section</u>	<u>Title</u>	<u>Page</u>
24-00	Description	24.1
24-10	(Pitch) Servo Assembly	24.7
24-20	(Roll) Servo Assembly	24.8
24-30	Flight Control Computer (FCC)	24.9
24-40	Control Panel	24.10
24-50	Cyclic Grip Assembly	24.11
24-60	Maintenance	24.12
24-61	Ground Checks	24.12
24-62	Troubleshooting	24.14

Intentionally Blank

CHAPTER 24

AUTOPILOT

24-00 Description

The HeliSAS autopilot system consists of two electric servomotors, a flight control computer, an autopilot control panel, and control buttons on the cyclic grip. One servomotor controls pitch and is installed in the control tunnel forward of the cyclic stick. The other servomotor controls roll and is installed under the pilot's seat. The servomotors are connected to the cyclic through electromagnetic clutches.

The flight control computer is installed on the forward panel under the pilot's seat, and the autopilot control panel is installed in the avionics stack.

The autopilot senses aircraft attitude using a combination of sensors in the flight control computer and an independent onboard attitude source such as the Attitude Heading Reference System (AHRS) for the Primary Flight Display (PFD). The computer then sends signals to the servomotors which are connected to the bottom of the cyclic in the control tunnel.

The primary autopilot mode is Stability Augmentation System (SAS) mode which maintains a steady helicopter attitude by applying corrective inputs to the cyclic. This is felt as a light cyclic centering force. Additional modes may be layered on top of SAS mode and are described below. The pilot can override as desired for maneuvering without disengaging the system. Only a few pounds of force at the cyclic are required for override, and the system will not disconnect due to pilot cyclic inputs.

The control panel has a row of buttons to control autopilot modes and annunciators to indicate mode status. A dark annunciator indicates that a mode is off, a white annunciator indicates that a mode is armed or on standby, and a green annunciator indicates that a mode is active.

When the avionics master is switched on, the autopilot performs a self-test and then enters SAS standby mode. All of the control panel indicators flash alternating white and green during the self-test. Four headset beeps occur at the beginning of the self-test as a check of the aural warning function. The SAS annunciator on the control panel turns steady white when the self-test is complete.

NOTE

Autopilot will not enter standby mode if attitude indicator is not functioning or indicated bank angle is greater than 6 degrees.

The autopilot SAS mode is engaged either by pressing the SAS button on the control panel or by pressing the TRIM button on the cyclic for more than 1.25 seconds. Additional modes are engaged by pressing the appropriate button on the control panel. The additional modes are disabled and will not engage at airspeeds below 44 KIAS or above 130 KIAS.

24-00 Description (continued)

To disengage any mode, push the appropriate button on the control panel.

NOTE

Disengaging SAS mode will also disengage all other modes.

Modes may also be disengaged using the AP OFF button on the cyclic. If only SAS mode is engaged, push the AP OFF button once to disengage. If additional modes are engaged, push the AP OFF button once to disengage all modes except SAS and a second time to disengage SAS mode, or push and hold the AP OFF button to disengage all modes including SAS.

NOTE

SAS disengagement should always be accompanied by four beeps in the headset. If beeps do not occur, maintenance is required.

Safety monitors automatically disengage individual modes or the entire system if a fault is detected. Automatic disengagement of SAS mode (or the entire system) is indicated by four beeps in the headset. Automatic disengagement of any mode other than SAS is indicated by a single beep in the headset. There is no audio indication for intentional disengagement of modes other than SAS.

NOTE

The system also automatically reverts to SAS mode at airspeeds below 44 KIAS or above 130 KIAS, accompanied by a single beep. The high speed limit is not intended to provide V_{ne} protection. It is the pilot's responsibility to observe V_{ne} limits.

The TRIM button is used to re-set the target attitude (to re-trim) while in SAS mode. Use a small amount of force to override the autopilot and then push and release the TRIM button at the new desired condition. If the force to override is objectionable, the TRIM button may be held down during maneuvers. The system will re-trim to the attitude at which the TRIM button is released. For Version 52, stick forces felt during override will gradually wash out to near zero without use of TRIM button if override is maintained.

NOTE

The system will not re-trim to angles more than approximately 10° in pitch or roll.

24-00 Description (continued)

NOTE

When engaging SAS mode from standby, for angles of less than approximately 10° in pitch and roll, SAS holds the current angles. If either pitch or roll is larger than approximately 10°, the system assumes an unusual attitude and gently levels the helicopter.

The autopilot is protected by a dedicated circuit breaker on the avionics bus (autopilot is not powered with the avionics master switch off).

Heading Mode (HDG) – maintains the heading selected by the heading bug on the directional gyro or Horizontal Situation Indicator (HSI) display. Aircraft can be steered using the heading bug.

Altitude Mode (ALT) – maintains altitude at the time of engagement or of last TRIM button release. The target altitude is reset each time the TRIM button is pressed and released.

NOTE

The autopilot uses pitch attitude to maintain altitude or follow an approach glidepath. It does not have any control of power setting. The pilot must manage power with the collective to control speed and rate of climb or descent. Make small, smooth power changes to allow the system to adjust to new power settings.

Navigation Mode (NAV) – tracks the active GPS or VLOC course displayed on the Course Deviation Indicator (CDI). If no CDI is installed, NAV will only track the active GPS course displayed on the GPS.

NAV may be armed prior to intercepting the active course. NAV annunciator is white when NAV is armed and turns green at course intercept. If HDG is active when NAV is armed, the autopilot will fly the selected heading until course intercept. If HDG is not active, the autopilot will select a 45° intercept angle.

24-00 Description (continued)

Vertical Navigation Mode (VRT) – tracks an ILS glideslope or GPS approach vertical guidance. Arm VRT (annunciator turns white when armed) prior to intercepting the glidepath. VRT annunciator will turn green at glidepath intercept.

NOTE

Pushing the ALT button while VRT is armed or active will turn off VRT. VRT must be re-armed or re-engaged as desired.

NOTE

Reducing power to approach setting just prior to glidepath intercept is recommended.

Speed Mode (SPD) (Version 52 only)

Speed mode uses cyclic pitch to control airspeed. Exact behavior varies with configuration of airspeed and altitude bugs on the PFD as described below.

The altitude bug is displayed above the altitude tape and the airspeed bug is displayed above the airspeed tape. The appearance of all dashes or a blank field indicates a bug is not set.

If an airspeed bug is not set, selecting SPD holds the current airspeed. The target speed is reset each time the trim button is pressed and released.

If an airspeed bug is set, selecting SPD holds airspeed at the bug setting. Changing the bug will change the target airspeed.

If an altitude bug is set, selecting SPD will also arm ALT (ALT LED white) for altitude capture. The mode will switch from SPD to ALT if the selected altitude is crossed. There will be a brief period in capture mode with the ALT LED flashing white/green.

NOTE

Do not change the selected altitude during ALT capture (ALT LED flashing white/green). System may pitch up or down to chase bug and may not capture altitude.

24-00 Description (continued)

NOTE

Different brands of PFD behave differently in terms of bug settings at power up and how bugs are manually set. Refer to PFD manufacturer's documents for proper use. Verify desired bug settings before engaging SPD mode.

Backcourse Mode (BC) (Version 51 only) – reverse CDI sensing for backcourse approaches.

Course on HSI should be set so that tail of course pointer points toward runway (set to inbound front course).

Airspeed Protection (Version 52 only) – Minimizes the possibility of the ALT mode to fly the helicopter to an airspeed below 44 KIAS due to insufficient power, or the VRT mode to fly the helicopter to an airspeed above 130 KIAS due to excess power when flying a precision approach glidescope. When triggered, it causes the longitudinal mode to change from ALT (at low airspeed) or VRT (at high airspeed) to SAS mode with a commanded pitch attitude of 2 degrees nose down. Since the mode change is not commanded by the pilot, a single warning beep is annunciated.

A. Removable Flight Controls

Disconnect the electrical connector for the left-hand trim button located near the quick release pin before removing the left cyclic grip. Reconnect the connector when installing the left cyclic grip.

B. Schematic

Refer to Figures 14-32A & 14-32B for autopilot (HeliSAS) electrical schematic.

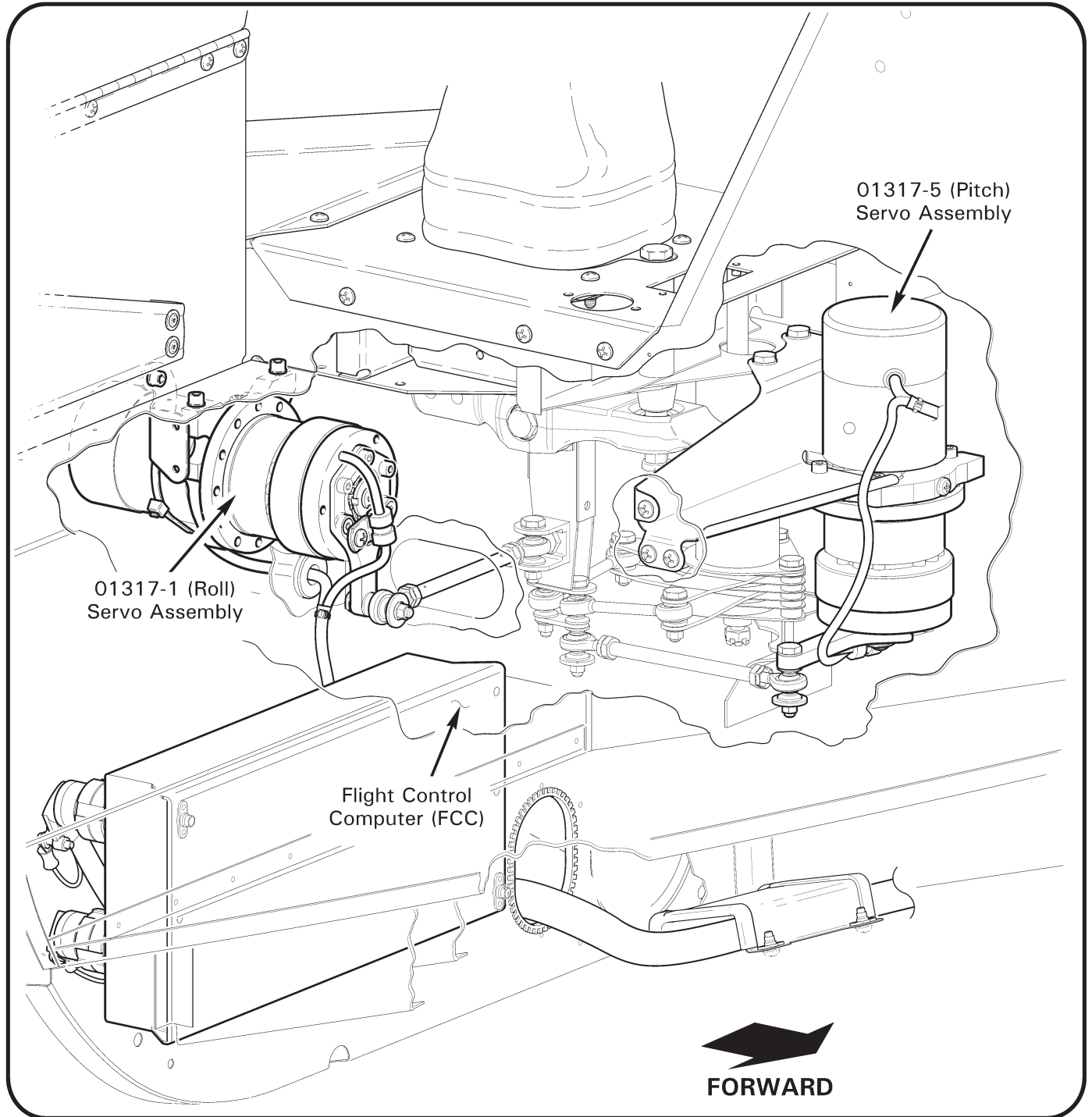

FIGURE 24-1 HELISAS AUTOPILOT SYSTEM

24-10 (Pitch) Servo Assembly**A. Removal**

1. Turn battery & avionics switches off and pull out AUTOPILOT (5 amp) circuit breaker at panel.
2. Remove C680-5 and C445 collective covers and C444 cyclic cover. Hinge front right seat forward. Remove C748-6 cover assembly under pilot's seat.
3. Remove avionics and avionics trays as required from lower console.

CAUTION

For pitch servo, adjust length of A336-7 push-pull tube assembly to 5.00 ± 0.03 inches between rod end centers.

4. Position cyclic stick full aft and apply cyclic friction. Remove hardware securing 01317-5 (pitch) servo assembly arm to A336-7 push-pull tube's rod end.
5. Disconnect servo harness from flight control computer's J1 PITCH receptacle. Cut and discard ty-rap(s) securing harness to M23190/1-2 clamp(s) and pull harness through access holes into control tunnel.
6. Support servo and remove hardware securing servo's brace to cyclic box and keel panels. Carefully remove servo from control tunnel.

B. Installation

1. Turn battery & avionics switches off and pull out AUTOPILOT (5 amp) circuit breaker at panel. Position cyclic stick full aft and apply cyclic friction.
2. Position 01317-5 (pitch) servo assembly in control tunnel and install hardware securing servo's brace to cyclic box. Standard torque bolts per § 23-32 and torque stripe per Figure 2-1. Install screws securing brace to keel panels. Verify security.
3. Route servo harness through access holes and connect harness to flight control computer's J1 PITCH receptacle. Install ty-rap(s) securing harness to M23190/1-2 clamp(s). Cinch ty-raps until snug without over-tightening, and trim tips flush with heads. Verify harness security.
4. Install hardware securing servo arm to A336-7 push-pull tube's rod end. Standard torque bolt per § 23-32 and torque stripe per Figure 2-1. Verify security.
5. Verify length of A336-7 push-pull tube assembly connected to pitch servo is 5.00 ± 0.03 inches between rod end centers.
6. Verify freedom of flight controls through full travel with and without friction applied.
7. Install avionics trays and avionics if removed. Verify security.
8. Push in AUTOPILOT circuit breaker (5 amp) at panel. Perform ground checks as appropriate per § 24-61.
9. Install C748-6 cover assembly under pilot's seat. Install C444 cyclic cover, and C445 and C680-5 collective covers. Verify security.

24-20 (Roll) Servo Assembly**A. Removal**

1. Turn battery & avionics switches off and pull out AUTOPILOT (5 amp) circuit breaker at panel.
2. Remove C680-5 and C445 collective covers. Remove C748-6 cover assembly under pilot's seat.

CAUTION

For roll servo, adjust length of A336-8 push-pull tube assembly to 4.20 ± 0.03 inches between rod end centers.

3. Position cyclic stick full left and apply cyclic friction. Remove hardware securing 01317-1 (roll) servo assembly arm to A336-8 push-pull tube's rod end.
4. Disconnect servo harness from flight control computer's J3 ROLL receptacle. Cut and discard ty-raps securing servo harness to autopilot harnesses.
5. Support servo and remove hardware securing servo's block assembly to keel panel and cabin assembly. Carefully remove servo from under pilot's seat.

B. Installation

1. Turn battery & avionics switches off and pull out AUTOPILOT (5 amp) circuit breaker at panel. Position cyclic stick full left and apply cyclic friction.
2. Position 01317-1 (roll) servo assembly under pilot's seat and install hardware securing servo's block assembly to keel panel and cabin assembly. Tighten screws. Verify security.
3. Connect servo harness to flight control computer's J3 ROLL receptacle. Install ty-raps securing servo harness to autopilot harnesses as required. Cinch ty-raps until snug without over-tightening, and trim tips flush with heads. Verify harness security.
4. Install hardware securing servo arm to A336-8 push-pull tube's rod end. Standard torque bolt per § 23-32 and torque stripe per Figure 2-1. Verify security.
5. Verify length of A336-8 push-pull tube assembly connected to roll servo is 4.20 ± 0.03 inches between rod end centers.
6. Verify freedom of flight controls through full travel with and without friction applied.
7. Push in AUTOPILOT circuit breaker (5 amp) at panel. Perform ground checks as appropriate per § 24-61.
8. Install C748-6 cover assembly under pilot's seat. Install C445 and C680-5 collective covers. Verify security.

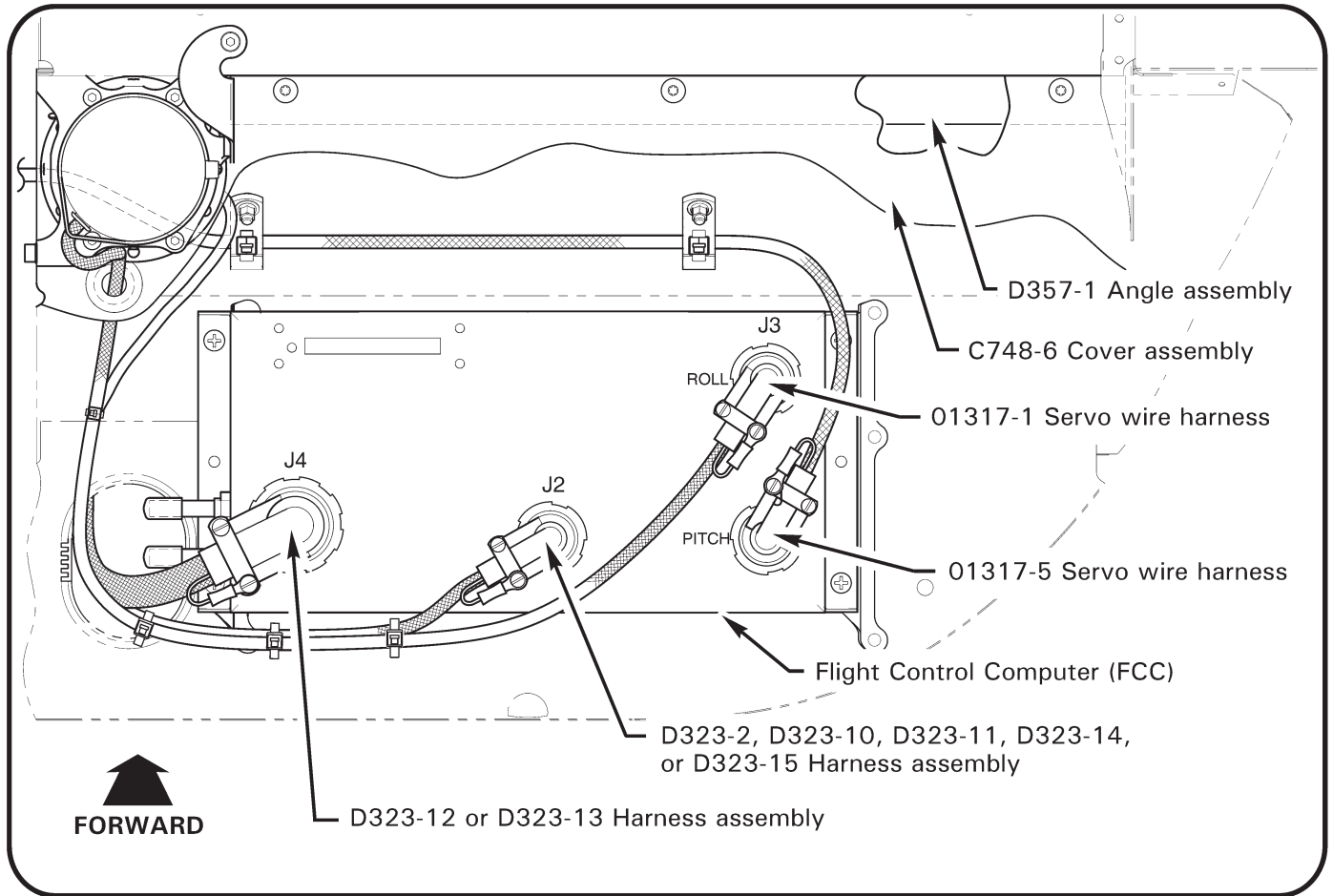

FIGURE 24-2 FLIGHT CONTROL COMPUTER

Version 51		Version 52	
FCC part number	01311-03-01	FCC part number	01311-02-101
Control panel part number	01309-01-01	Control panel part number	01309-03-01

TABLE 24-1 SOFTWARE VERSIONS AND EQUIPMENT PART NUMBERS

24-30 Flight Control Computer (FCC)

A. Removal

1. Turn battery & avionics switches off and pull out AUTOPILOT (5 amp) circuit breaker at panel.
2. Remove C748-6 cover assembly under pilot’s seat.
3. Disconnect D323 harness assemblies and servo assembly harnesses from flight control computer’s J1 PITCH, J2, J3 ROLL, and J4 receptacles.
4. If installed, disconnect pitot and static tubes from computer. Plug elbows and tubes.
5. Support computer and remove screws securing computer to cabin assembly. Carefully remove computer from under pilot’s seat.

24-30 Flight Control Computer (continued)**B. Installation****NOTE**

Refer to Table 24-1. Flight control computer (FCC) and control panels for Software Version 51 and Software Version 52 are not interchangeable. Verify part number compatibility prior to installation.

1. Turn battery & avionics switches off and pull out AUTOPILOT (5 amp) circuit breaker at panel.
2. Position flight control computer under pilot's seat and install screws securing computer to cabin assembly. Tighten screws. Verify security.
3. If installed, remove plugs and connect pitot and static tubes to computer. Perform pitot and static system leak checks per § 13-10.
4. Connect D323 harness assemblies and D354 servo assembly harnesses to computer's J1 PITCH, J2, J3 ROLL, and J4 receptacles. Install ty-raps securing harnesses as required. Cinch ty-raps until snug without over-tightening, and trim tips flush with heads. Verify harness security.
5. Verify freedom of flight controls through full travel with and without friction applied.
6. Push in AUTOPILOT circuit breaker (5 amp) at panel. Perform ground checks as appropriate per § 24-61.
7. Install C748-6 cover assembly under pilot's seat.

24-40 Control Panel**A. Removal**

1. Turn battery & avionics switches off and pull out AUTOPILOT (5 amp) circuit breaker at panel.
2. Loosen quarter-turn fasteners securing control panel to console assembly.
3. Carefully unplug harness from control panel and remove panel.

24-40 Control Panel (continued)**B. Installation****NOTE**

Refer to Table 24-1. Flight control computer (FCC) and control panels for Software Version 51 and Software Version 52 are not interchangeable. Verify part number compatibility prior to installation.

1. Turn battery & avionics switches off and pull out AUTOPILOT (5 amp) circuit breaker at panel.
2. Carefully plug-in harness to control panel.
3. Tighten quarter-turn fasteners securing control panel to console assembly. Verify security.
4. Push in AUTOPILOT circuit breaker (5 amp) at panel. Perform ground checks as appropriate per § 24-61.

24-50 Cyclic Grip Assembly**A. Grip Angle Adjustment**

1. Loosen cap screws securing pilot's cyclic grip, block assembly, and bar to grip weldment.
2. Rotate grip about weldment to desired angle. Special torque cap screws to 40 in.-lb.

B. Removal and Installation

Refer to § 8.121 & 8.122 for cyclic grip assembly removal and installation procedures.

To access grip switches:

1. Remove MS24693-S1 screws securing C214-27 plate to D379-1 grip. Remove switch nuts and lockwashers to free switches from plate.
2. Install switch lockwashers (new) and nuts and tighten switches to plate; verify switch security. Install screws securing plate to grip.
3. Turn battery switch on and perform ground checks as appropriate per § 24-61.

C. Schematic

Refer to Figure 14-21 for C024 electrical system schematic.

24-60 Maintenance

24-61 Ground Checks

NOTE

Perform the following ground checks after component replacement or other repairs have been performed on the autopilot system. Perform ground checks after any incident that may have affected autopilot or related equipment prior to return to service.

NOTE

Refer to § 24-62 for troubleshooting if any of the following ground checks cannot be verified.

1. Turn battery & avionics switches on. Verify four beeps in headset and control panel LEDs alternate white/green:

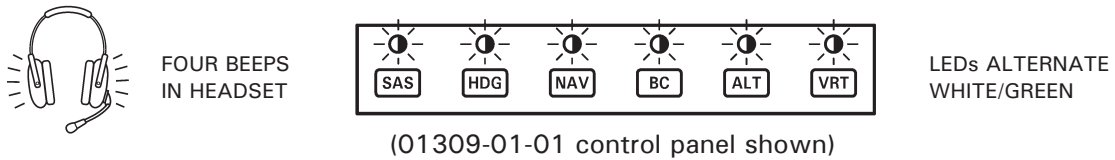

2. Verify SAS enters standby mode approximately 6 seconds after PFD aligns. Verify no sound in headset and control panel SAS LED is white, other LEDs are dark:

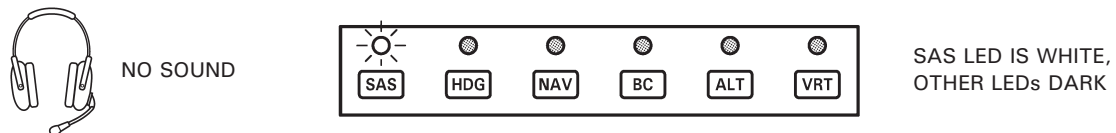

3. With cyclic friction full off, verify cyclic moves freely within hydraulic servo longitudinal and lateral deadbands.
4. Engage SAS mode (cyclic should feel "energized"). Verify no sound in headset and control panel SAS LED is green, other LEDs are dark:

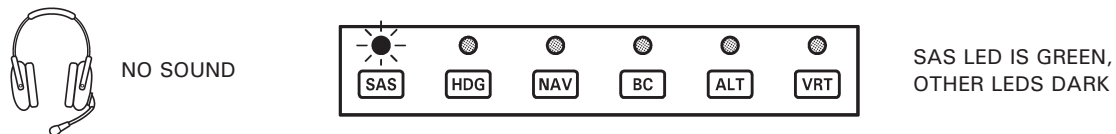

5. With SAS engaged, displace cyclic at least 1 inch from neutral position and verify a vibrating resistance is encountered. Perform check for roll & pitch axes.

24-61 Ground Checks (continued)

6. Refer to step 2. Engage SAS and verify SAS disengages when control panel's SAS button is depressed or when AP OFF button on the cyclic grip is depressed. Verify four beeps in headset and control panel SAS LED is white, other LEDs are dark:



FOUR BEEPS
IN HEADSET

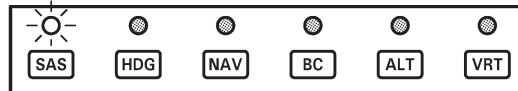

SAS LED IS WHITE,
OTHER LEDS DARK

7. Perform pitot system leak test per § 13-10 and, while airspeed indicates > 50 knots: Engage SAS and ALT modes. Verify no sound in headset and SAS & ALT LEDs are green, other LEDs are dark:



NO SOUND

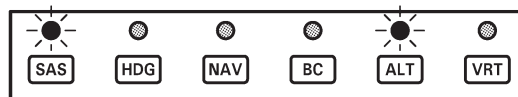

SAS & ALT LEDs ARE
GREEN, OTHER LEDS
DARK

8. Disengage ALT mode. Verify no sound in headset and SAS LED is green, other LEDs are dark:



NO SOUND

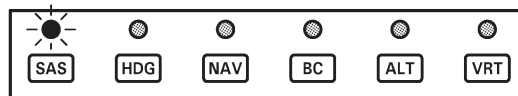

SAS LED IS GREEN,
OTHER LEDS DARK

9. Refer to steps 7 & 8. Engage SAS and HDG modes. Verify no sound in headset and SAS & HDG LEDs are green, other LEDs are dark. Disengage HDG mode. Verify no sound in headset and SAS LED is green, other LEDs are dark.
10. Engage SAS, HDG, and ALT modes. Verify no sound in headset and SAS, HDG, and ALT LEDs are green, other LEDs are dark. Press AP OFF button on cyclic grip. Verify no sound in headset and SAS LED is green, other LEDs are dark.
11. Engage SAS, HDG, and ALT modes. Verify no sound in headset and SAS, HDG, and ALT LEDs are green, other LEDs are dark. Press AP OFF button twice on cyclic grip. Verify four beeps in headset and SAS LED is white, other LEDs are dark.

24-62 Troubleshooting

CAUTION
Adjustment to autopilot equipment is not permitted.

PROBLEM	ACTION
Control panel lights do not illuminate or flash when master switch is turned on.	Verify computer is getting power.
	Return computer to RHC.
System does not enter standby-mode (lights flash continuously).	Verify attitude indicator bank angle less than 6 degrees.
	Verify attitude indicator output between 13 and 14 pins is less than 0.3 volts at connector.
	Check wiring between attitude indicator and computer.
	Contact RHC Technical Support.
SAS does not engage when TRIM button depressed for longer than 1.25 seconds; pressing TRIM button does not reset reference attitude; pressing TRIM button does not reset reference altitude in altitude hold.	Check wiring between TRIM button and computer.
	Verify integrity of TRIM button.
	Return computer to RHC.
SAS does not disengage when cyclic grip AP OFF button depressed.	Check wiring between AP OFF button and computer.
	Verify integrity of AP OFF button.
	Return computer to RHC.
SAS does not engage or disengage when control panel buttons pressed.	Engage and/or disengage SAS using cyclic grip buttons. If system responds properly, failure is in control panel or associated wiring to computer.
	Contact RHC Technical Support.
SAS does not hold pitch attitude, but holds roll attitude or vice versa.	Check servo-to-cyclic linkage.
	Check wiring between faulty servo and computer.
	Return faulty servo and computer to RHC.
SAS disengages unintentionally (accompanied by four beeps in headset).	Contact RHC Technical Support.
Autopilot mode disengages unintentionally, and reverts to SAS mode (accompanied by single beep in headset).	Determine if navigation signal may have gone invalid due to operational reason.
	Check wiring between appropriate instrument/avionics and computer.
	Check instrument/avionics for failure flags (steady and intermittent).
Cyclic vibrates erratically, SAS does not disengage.	Manually override SAS, system should disengage automatically.
	Contact RHC Technical Support.
Helicopter enters low frequency pitch oscillation when ALT engaged; helicopter diverges nose-up or nose-down when ALT engaged.	Return computer to RHC.

24-62 Troubleshooting (continued)

PROBLEM	ACTION
ILS glideslope tracking performance is poor.	Check for excessive friction in longitudinal cyclic.
	Check GPS output to computer.
Cyclic force seems higher than normal with SAS disengaged.	Verify servo clutches are disengaged, and clutch arms do not move when SAS is Off or in standby-mode.
No aural warning in headset when SAS is disengaged.	Check wiring to unswitched audio input to audio panel.

Intentionally Blank

**CHAPTER 25
HYDRAULICS**

<u>Section</u>	<u>Title</u>	<u>Page</u>
25-00	Description	25.1

Intentionally Blank

CHAPTER 25**HYDRAULICS**25-00 Description

Reserved.

Intentionally Blank

CHAPTER 26

LIGHTS

<i>Section</i>	<i>Title</i>	<i>Page</i>
26-00	Description	26.1
26-10	Exterior Lights	26.1
26-11	Strobe Light(s)	26.1
26-12	Navigation Lights	26.2
26-13	Landing Lights	26.4
26-20	Interior Lights	26.4
26-21	Panel Light	26.4

Intentionally Blank

CHAPTER 26

LIGHTS

26-00 Description

A red anti-collision light is installed on the tailcone and is controlled by the strobe switch. Position lights are installed on each side of the cabin and in the tail and are controlled by the nav lights switch. Post and internal lights (earlier aircraft) or a light at the top of the windshield (later aircraft) illuminate the instruments. Instrument lighting is active when the nav lights switch is on and lighting is dimmed via the knob above the nav lights switch. An overhead map light mounted on a swivel is controlled by an adjacent switch. The map light may be used for emergency lighting of the instrument panel. An additional cabin light with an adjacent switch is located just aft of the map light (later aircraft).

Two landing lights are installed in the nose at different vertical angles. One wide angle and one narrow-beam light are used to increase the lighted area (later aircraft). One landing light switch controls both lights and is located on the cyclic center post.

NOTE

Landing lights operate only when clutch actuator switch is in the engage position.

NOTE

Continuous operation of landing and position lights in flight is recommended to promote collision avoidance.

An optional flashing light may be mounted on the tailcone in addition to the standard anti-collision light. On earlier aircraft, the optional light is controlled by the strobe switch and the standard light is powered whenever the battery switch is on. On later aircraft, the optional light is controlled by a separate switch.

26-10 Exterior Lights26-11 Strobe Light(s)**A. Removal**

1. Turn battery switch off. Pull out STROBE circuit breaker (5 amp, or 7½ amp if forward strobe is installed) at panel.
2. Remove hardware securing A708 strobe light assembly's retainer, lens, and gasket to light assembly.
3. Remove hardware securing light assembly to tailcone mount.
4. Remove hardware securing ground wire, if ground is installed at mount. Disconnect light assembly harness from airframe harness and remove light assembly.

26-11 Strobe Light(s) (continued)**B. Installation**

1. Turn battery switch off. Pull out STROBE circuit breaker (5 amp, or 7½ amp if forward strobe is installed) at panel.
2. Install hardware securing A708 strobe light assembly's ground wire to tailcone mount, if ground is installed at mount. Connect light assembly's harness to airframe harness at connectors.
3. Install hardware securing light assembly to tailcone mount (white forward strobe: two missing columns of LEDs facing forward). Verify security.
4. Install hardware securing light assembly's gasket, lens, and retainer to light assembly. Verify security.
5. Push in STROBE circuit breaker (5 amp, or 7½ amp if forward strobe is installed) at panel. Turn battery switch and strobe switch(es) on and verify function. Turn battery switch off.

26-12 Navigation Lights**A. Removal**

1. Turn battery switch off. Pull out LTS circuit breaker (5 amp) at panel.
2.
 - a. LED Position Lights: Remove screw securing retainer, lens, and gasket to light assembly. Remove hardware securing light assembly, gasket, and ground wire to chin. Cut and discard ty-rap securing excess wire to light assembly, pull out light assembly, and disconnect light assembly harness from airframe harness at connector.
 - b. Incandescent Position Lights: Remove screw securing retainer, lens, and gasket to light assembly. Remove lamp from position light assembly.
 - c. LED Tail Light: Remove screws securing retainer, lens, gasket, and light assembly to C529-1 mount assembly. Pull out light assembly and disconnect light assembly harness from airframe harness at connector.
 - d. Incandescent Tail Light: Remove screws securing retainer, lens, gasket, and light assembly to C529-1 mount assembly. Remove lamp.

26-12 Navigation Lights (continued)**B. Installation**

1. Turn battery switch off. Pull out LTS circuit breaker (5 amp) at panel.
2.
 - a. LED Position Lights: Connect light assembly harness to airframe harness at connector. Install hardware securing light assembly, gasket, and ground wire to chin. Verify security. Install ty-rap securing excess wire to light assembly. Cinch ty-rap until snug without over-tightening, and trim tip flush with head. Install screw securing retainer, lens, and gasket to light assembly. Verify security.
 - b. Incandescent Position Lights: Install lamp in position light assembly. Install screw securing retainer, lens, and gasket to light assembly. Verify security.
 - c. LED Tail Light: Connect light assembly harness to airframe harness at connector. Install screws securing retainer, lens, gasket, and light assembly to C529-1 mount assembly. Verify security.
 - d. Incandescent Tail Light: Install lamp in tail light assembly. Install screws securing retainer, lens, gasket, and light assembly to C529-1 mount assembly. Verify security.
3. Push in LTS circuit breaker (5 amp) at panel. Turn battery switch and LTS switch on and verify function. Turn battery switch and LTS switch off.

C. LED Assembly Replacement

1. Turn battery switch off. Pull out LTS circuit breaker (5 amp) at panel.
2.
 - a. Position Lights: Remove incandescent position light assembly per Part A step 2a.
 - b. Tail Light: Remove screws securing retainer, lens, gasket, and light assembly to C529-1 mount assembly. Pull out light assembly and disconnect light assembly harness from airframe harness at connector, if applicable, or perform the following:
 1. Cut A689-2 or -3 light assembly wires flush with back of assembly.
 2. Strip wires & crimp (1) B263-2 socket on each wire. Inspect crimps per § 23-84.
 3. Install sockets/wires in B263-13 housing, positive wire in position 1, ground wire in position 2. Verify polarity using multimeter.
3.
 - a. Position Lights: Install LED position light assembly per Part B step 2a.
 - b. Tail Light: Install LED position light assembly per Part B step 2c.
4. Push in LTS circuit breaker (5 amp) at panel. Turn battery switch and LTS switch on and verify function. Turn battery switch and LTS switch off.

26-13 Landing Lights**NOTE**

Landing lights operate only when clutch actuator switch is in the engage position.

NOTE

Verify correct landing light circuit breaker installed:

28v HID landing lights	B297-7 (7 ½ amp)
28v sealed beam landing lights	B297-10 (10 amp)
14v HID landing lights	B297-15 (15 amp)
14v sealed beam landing lights	B297-20 (20 amp)

A. Removal

1. Turn battery switch off. Pull out LAND LT circuit breaker (see note) at panel.
2. Remove screws securing C526-1 retainer or C526-2 bezel to chin and remove retainer or bezel.
3. As required, remove screws securing C526-3 retainers and lamps to C526-2 bezel. Disconnect landing light cable from lamp and remove lamp.

B. Installation

1. Turn battery switch off. Pull out LAND LT circuit breaker (see note) at panel.

NOTE

B557-1 (spot) landing light is installed in LH location and B557-2 (flood) taxi light is installed in RH location, HID installations only.

2. As required, route landing light cable(s) thru C526-3 retainer(s). Connect landing light cable to landing light.
3. As required, install screws securing C526-3 retainer(s) and lamp(s) to C526-2 bezel. Install screws securing C526-1 retainer or C526-2 bezel to chin.
4. Push in LAND LT circuit breaker (see note) at panel. Turn battery switch and landing light switch on (cyclic center post) and verify function. Turn battery switch and landing light switch off.

26-20 Interior Lights26-21 Panel Light**A. LED Assembly Replacement**

1. Turn battery switch off. Pull out LTS circuit breaker (5 amp) at panel.
2. Remove hardware securing G196 light assembly to windshield stiffener. Remove two cap screws securing cover and LED assembly to housing. Disconnect LED assembly wires from airframe harness and remove LED assembly.
3. Connect C238-2289 (white) airframe harness wire to new LED assembly red wire, and C238-2290 airframe harness wire to LED assembly black wire. Install cover (chamfer facing away from housing) and install two cap screws. Install hardware securing G196 light assembly to windshield stiffener. Verify security.
4. Push in LTS circuit breaker (5 amp) at panel. Turn battery switch and LTS switch on and verify function. Verify dimming knob adjusts brightness. Turn battery switch and LTS switch off.

Intentionally Blank

CHAPTER 27**DOORS AND WINDOWS**

<u>Section</u>	<u>Title</u>	<u>Page</u>
27-00	Description	27.1
27-10	Door Assembly	27.1
27-11	Door Lock Replacement	27.4
27-12	Weather Seal (Door Assembly) Replacement	27.4
27-13	Gas Springs	27.7
27-20	Door Vent Replacement	27.7
27-21	Weather Seal (Door Vent) Replacement	27.7
27-22	Door Vent Hinge Replacement	27.8
27-23	Pivot Friction Adjustment	27.8
27-30	Windshield Installation	27.11
27-31	Standard (Acrylic) Windshield Installation	27.11
27-32	Impact-Resistant (Polycarbonate) Windshield Installation	27.14
27-33	Yaw String	27.21

Intentionally Blank

CHAPTER 27

DOORS AND WINDOWS

27-00 Description

The R44 has four passenger (cabin) doors. All four cabin doors may be removed and installed by maintenance personnel or pilots.

Passenger doors are constructed of fiberglass and thermoplastics. Passenger doors, locks, weather seal, gas springs, and door vents and hinges may be replaced, and vent pivot friction may be adjusted.

Two windshield halves are retained in aluminum frames and an aluminum tubular bow oriented vertically along the helicopter's centerline. A standard (acrylic) windshield installation and an impact-resistant (polycarbonate) windshield installation are available. Refer to § 27-30 for detailed description.

27-10 Door Assembly**A. Cleaning**

Refer to § 23-10 Part B for cleaning windows.

B. Removal

1. Refer to Figures 27-1 and 27-2. To disconnect door from gas spring mechanism:
 - a. Forward Doors: Pull D573-4 rod up and off of arm assembly ball joint.
 - b. Aft Doors: Insert flat-tip screwdriver and pry up spring clip locking C394-1 gas spring to channel ball joint. Pull gas spring up and off of ball joint.
2. Remove rings from door hinge pins, lift pins up from door frame hinge assemblies, and remove door.
3. Adjust weight and balance per applicable Pilot's Operating Handbook Section 6.

C. Installation**WARNING**

Failure to install a ring in each door's two hinge pins may allow door to depart aircraft in flight.

1. Refer to Figures 27-1 and 27-2. Align and insert door hinge pins in door frame hinge assemblies.
2. Align forward door D573-4 rod with arm assembly ball joint, or aft door C394-1 gas spring with channel ball joint, and push down to lock.
3. Install rings in door hinge pins.
4. Adjust weight and balance per applicable Pilot's Operating Handbook Section 6.

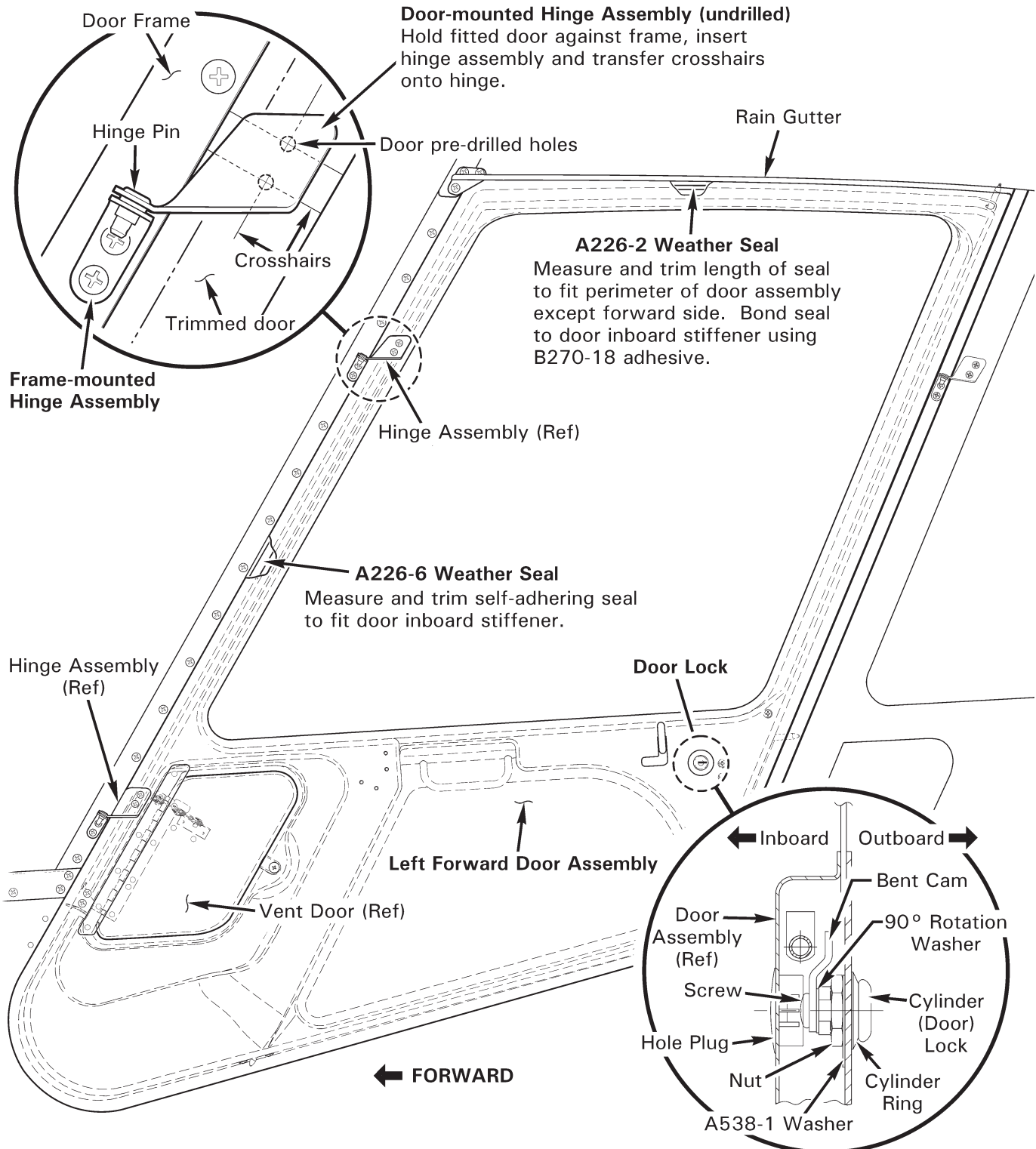

FIGURE 27-1 DOOR ASSEMBLY

27-10 Door Assembly (continued)**D. Replacement****CAUTION**

Use proper respiratory protection when handling fiberglass.

CAUTION

Protect door windows and paint from scratches or scuff marks when door maintenance is performed on workbench.

1. Refer to Figure 27-1. As required, lay masking tape on surfaces of door frame, new door hinges, and new door, to mark with soft pencil.
2. Press new door forward and top edge weather seals against door frame recess (rain gutter interferes with top edge until trimmed).
3. Using soft pencil, trace door forward edge onto masked frame, then transfer approximate edge distance to door. From inside cabin, estimate approximate material to be removed from door top edge, then transfer approximate edge distance to door. Remove door.
4. Using 60-grit grinder, trim forward and top door edges. Perform steps 1 thru 3 until weather seals sit approximately even against door frame recess.
5. Using soft pencil and a straight edge, draw cross hairs through (centers of) door upper hinge assembly pre-drilled holes. Hold fitted door against frame, insert new (door-mounted) hinge assembly in frame-mounted hinge assembly, and transfer cross hairs onto hinge. Remove hinge and door.
6. Drill two 0.170-inch diameter holes at cross hair intersections in hinge assembly and deburr. Remove tape, clean up debris, and prepare hinge assembly and door clamping surfaces using approved solvents per § 23-70.
7. Install upper hinge assembly on door and special torque screws per § 23-33.
8. Repeat steps 5 thru 7 for lower door-mounted hinge assembly.
9. Install door. Using 60-grit grinder, trim edges as required for final fitting. Verify doors open and close smoothly and latch correctly. Remove door and bevel edges using 60-grit sandpaper.
10. Prepare surfaces with solvent and touch-up door using approved materials per § 23-70. Install new door per Part C.

27-11 Door Lock Replacement

CAUTION

Protect door windows and paint from scratches or scuff marks when door maintenance is performed on workbench.

1. Remove door per § 27-10.
2. Refer to Figure 27-1. Remove hole plug opposite key slot on door interior.
3. Remove screw, bent cam, and 90° rotation washer. Remove nut and A538-1 washer. Press and catch cylinder lock and ring through door.
4. Install new cylinder lock and ring in door. Install lock so key is vertical with teeth down in locked position. Apply thin coat B270-10 adhesive on screw threads, install hardware, and tighten screw.
5. Bond hole plug in place using B270-9 adhesive.

27-12 Weather Seal (Door Assembly) Replacement

1. Remove damaged weather seal using plastic wedge or putty knife. Remove hardened adhesive using approved solvent per § 23-70, or 60-grit sandpaper, as required.
2. Refer to Figure 27-1. Measure and trim continuous length of A226-2 seal to fit perimeter of door except forward side, as shown. Neatly bond seal to stiffener using B270-18 adhesive. Wipe away excess adhesive prior to curing.
3. Measure and trim length of A226-6 seal to fit forward side of door. Remove self-adhesive preserving strip and neatly bond seal to stiffener.

Intentionally Blank

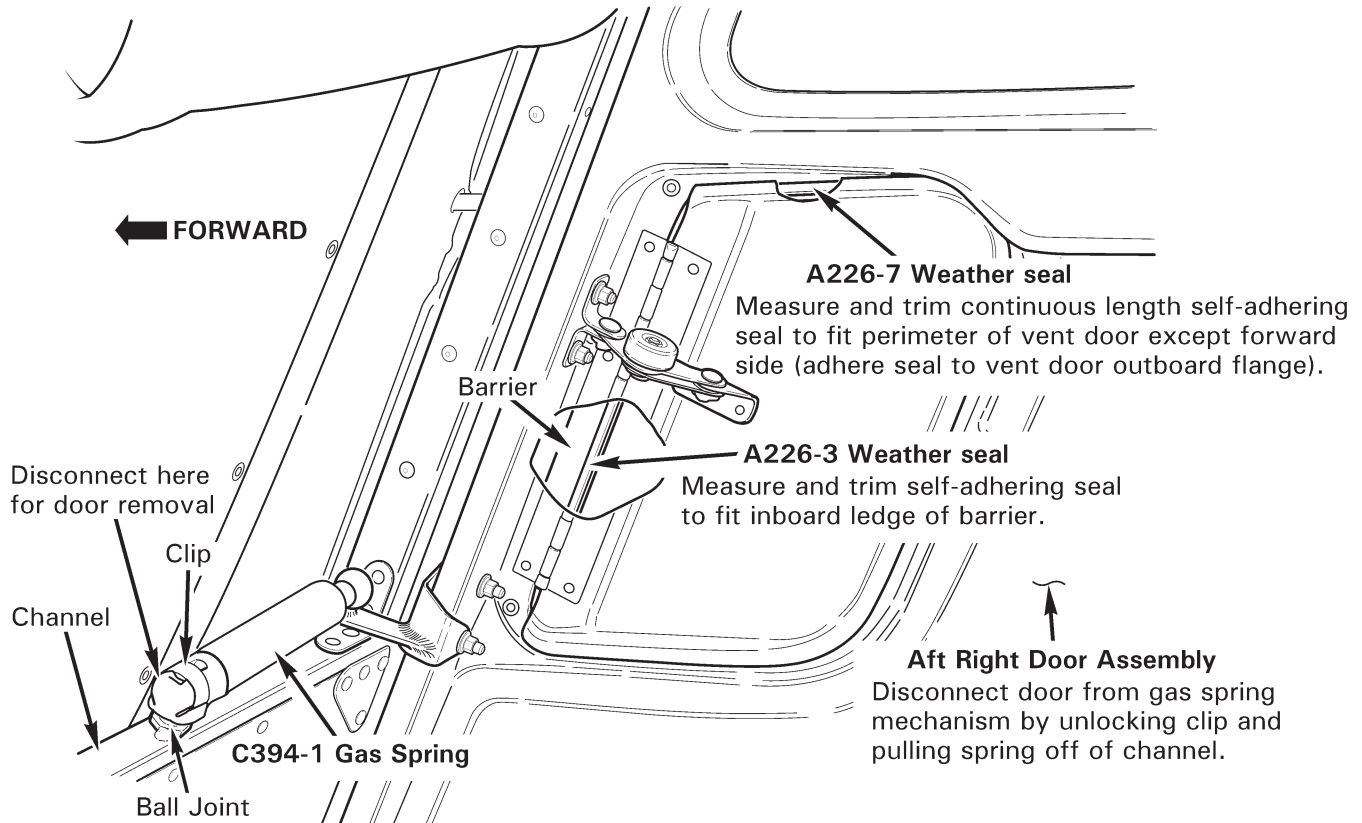
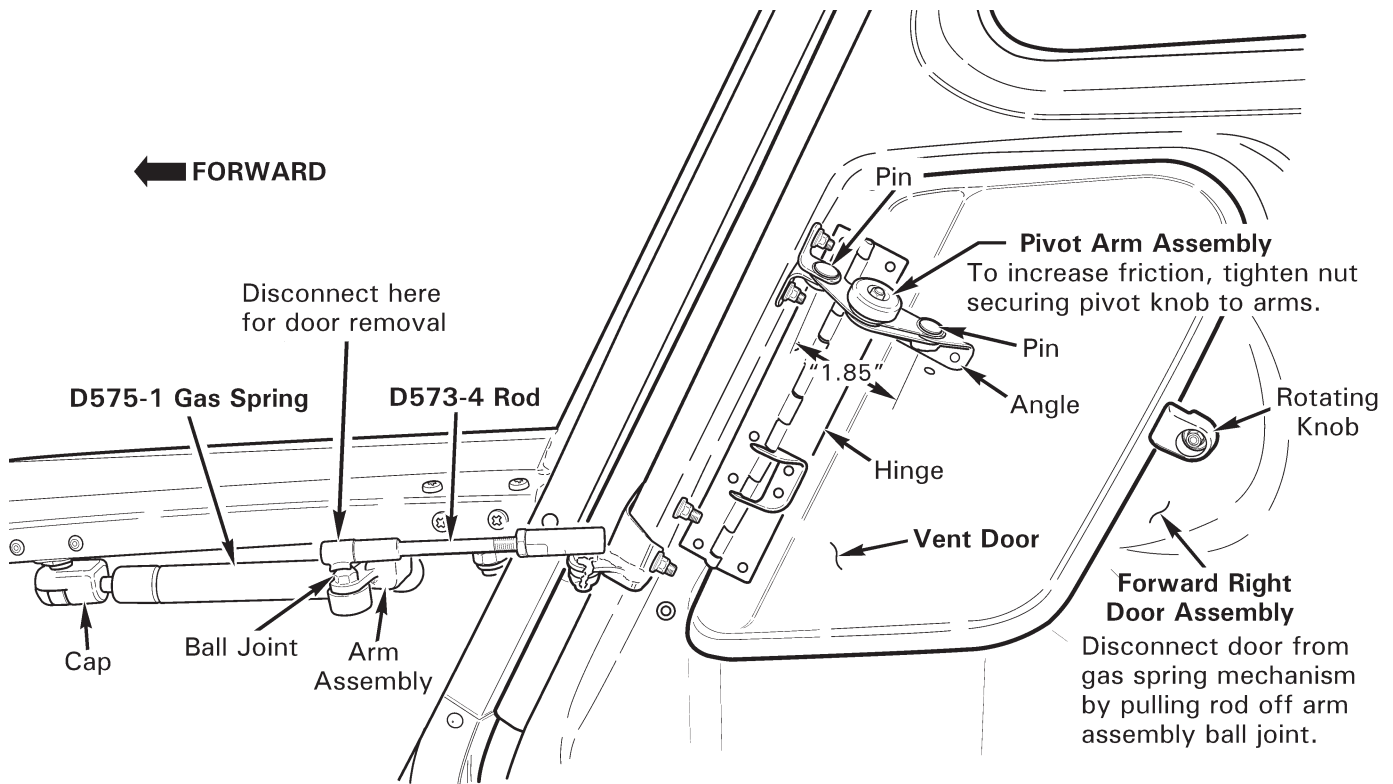

FIGURE 27-2 GAS SPRINGS AND DOOR VENTS

27-13 Gas Springs

A. Removal

1. a. Forward Doors: Insert flat-tip screwdriver and pry down on caps to unlock D575-1 gas spring from ball joints. Push gas spring down and off of ball joints.
- b. Aft Doors: Insert flat-tip screwdriver and pry up spring clips to unlock C394-1 gas spring from ball joints. Pull gas spring up and off of ball joints.

B. Installation

1. a. Forward Doors: Unlock D575-1 gas spring caps. Snap gas spring onto ball joints and lock caps.
- b. Aft Doors: Insert flat-tip screwdriver and pry up C394-1 gas spring spring clips. Snap gas spring onto ball joints and release clips.

27-20 Door Vent Replacement

CAUTION

Use proper respiratory protection when handling fiberglass.

1. Refer to Figure 27-2. Drill out rivets securing hinge and pivot arm assembly angle to door vent. Rotate knob to unlock and remove door vent.
2. Using 60-grit grinder, trim new vent door forward edge as required to match door recess and smooth corners. Bevel edges using 60-grit sandpaper.
3. Hold fitted door vent in recess and match drill hinge four 0.098-inch diameter holes. Smooth hole edges; clean up debris. Prepare surfaces for clamping using approved solvents per § 23-70. Install rivets securing door to hinge.
4. Extend pivot arm to approximately 1.85 inch between center of pins. Match drill pivot arm assembly angle two 0.098-inch diameter holes. Smooth hole edges; clean up debris. Prepare surfaces for clamping using approved solvents per § 23-70. Install rivets securing door to arm assembly angle. Verify vent door opens and closes smoothly and latches correctly.

27-21 Weather Seal (Door Vent) Replacement

1. Remove damaged weather seal using plastic wedge or putty knife. Remove hardened adhesive using approved solvent per § 23-70, or 60-grit sandpaper, as required.
2. Refer to Figure 27-2. Measure and trim continuous length of A226-7 seal to fit perimeter of vent door except forward side, as shown. Remove self-adhesive preserving strip and neatly bond seal to stiffener.
3. Measure and trim length of A226-3 seal to fit ledge of barrier. Remove self-adhesive preserving strip and neatly bond seal to stiffener.

27-22 Door Vent Hinge Replacement**CAUTION**

Protect door windows and paint from scratches or scuff marks when door maintenance performed on workbench.

1. Remove door per § 27-10.
2. Refer to Figure 27-2. Drill out rivets securing hinge to door assembly and door vent. Remove hinge.
3. Smooth hole edges; clean up debris. Prepare surfaces for clamping using approved solvents per § 23-70.
4. Refer to § 27-20. Verify proper vent door fit; install rivets securing hinge to door assembly and door vent. Prepare surfaces and touch-up rivet heads and hinge using approved materials per § 23-70.

27-23 Pivot Friction Adjustment

To increase pivot arm assembly friction, tighten nut securing pivot knob to arms. Do not overtighten screw. No thread exposure required beyond nut.

Intentionally Blank

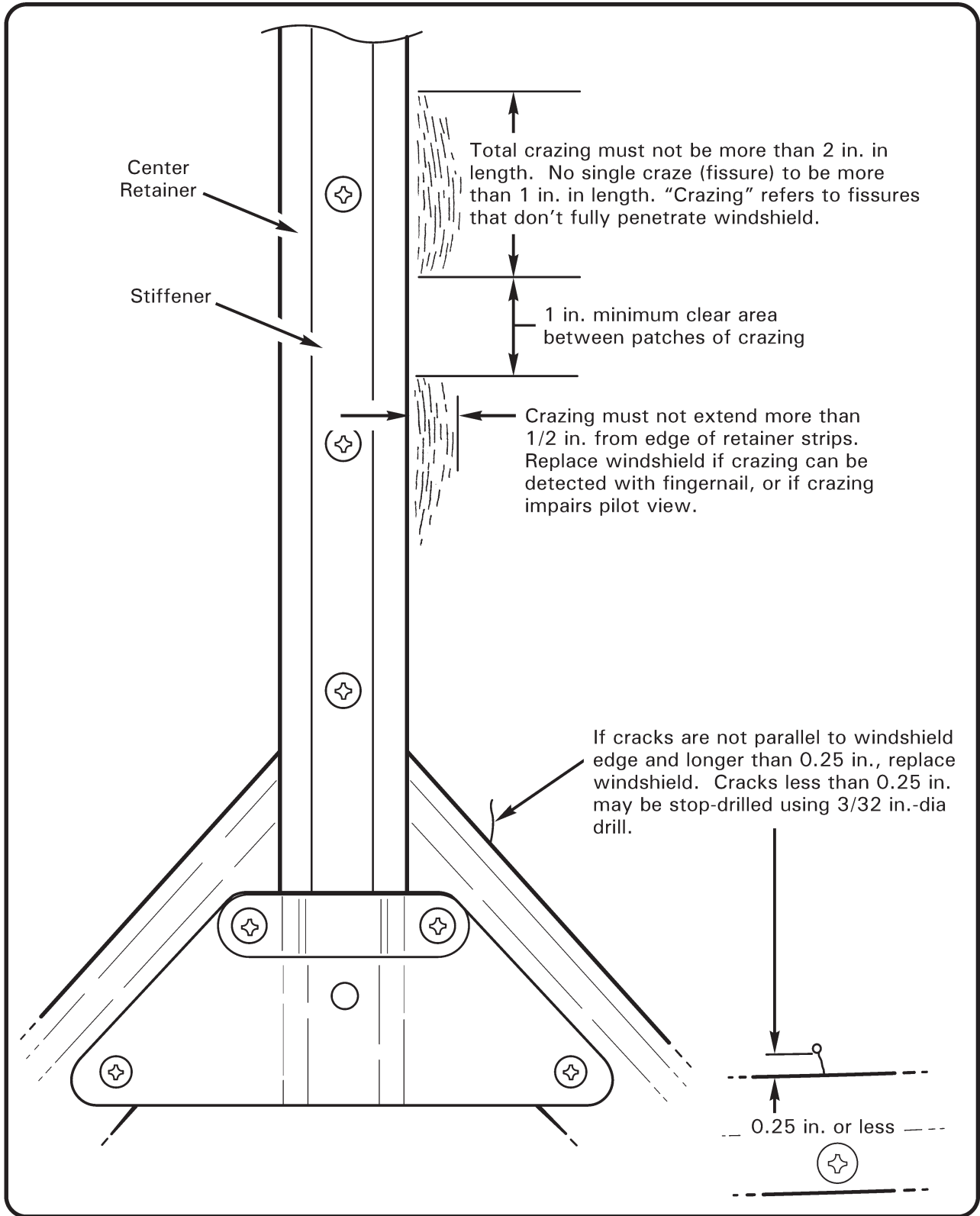

FIGURE 27-3 WINDSHIELD INSPECTION (ACRYLIC WINDSHIELD SHOWN)

27-30 Windshield Installation

27-31 Standard (Acrylic) Windshield Installation

A. Description

Acrylic windshields are sandwiched between thin aluminum retainers that are screwed to the door and windshield frames. An adhesive/sealant is applied between the retainers and the windshields for security and weatherproofing.

B. Cleaning

Refer to § 23-10 Part B for cleaning windshield.

C. Inspection

Inspect both windshields for cracks and crazing adjacent to retainers per Figure 27-3. If cracks exceed these limits, replace damaged windshield per § 27-31 Part F.

Minor defects or imperfections that do not impair pilot visibility or indicate impending structural failure are acceptable.

D. Removal

1. Remove forward door assembly per § 27-10 Part B. Remove hardware securing A228 (upper) and C228 (lower) hinge assembly to door frame and remove hinges.

NOTE

If windshield is to be reinstalled, prior to removal, tape protective paper or film to the inside and outside of the windshield to prevent damage.

2. Remove hardware securing C238-27 or C238-28 (side) retainer to door frame and remove retainer.
3. Install upper hinge assembly, and install door assemblies for cabin structure support with windshield removed.
4. Support windshield. With a second person inside cabin to remove nuts, latch forward doors. Remove hardware securing C238-29 (upper) retainer, B409-5 gusset, D805-2 restraint, C366-5 bracket, C366-8 retainer, C367 (lower) retainers, B295-1 clip with yaw string, C367-12 stiffener, and C367-10 (center) retainer to cabin and remove parts. Remove windshield.
5. Remove sealant from cabin and parts.
6. If windshield is to be reinstalled, remove sealant from windshield.
7. Repeat steps to remove opposite-side windshield, as required.

27-31 Standard (Acrylic) Windshield Installation (continued)**E. Installation****NOTE**

Prior to installation, if not previously accomplished, tape protective paper or film to the inside and outside of the windshield to prevent damage.

1. Verify sealant has been removed from cabin, parts, and windshield.
2. Position windshield on helicopter and cleco retainers to frames.
3. Attach 1/2"-wide masking tape to windshield along edge of retainers to catch sealant squeeze-out during retainer installation.
4. Remove C238-27 or C238-28 (side) retainer and install A228 (upper) and C228 (lower) door hinge assemblies. Install forward door assemblies for cabin structure support during windshield installation.
5. Remove C367-10 (center) retainer. Run a bead of B270-26 sealant along entire edge of tape line. Install hardware securing center retainer and C367-12 stiffener (do not install B295-1 clip) to cabin; special torque screws per § 23-33. Remove tape and wipe off excess sealant with cheesecloth wet with lacolene.
6. Remove C367 (lower) retainers. Run a bead of B270-26 sealant along entire edge of tape line. With a second person inside cabin to tighten nuts, latch forward doors. Install hardware securing lower retainers, C366-8 retainer, and C366-5 bracket to cabin. Remove tape and wipe off excess sealant with cheesecloth wet with lacolene.
7. Remove C238-29 (upper) retainer. Run a bead of B270-26 sealant along entire edge of tape line. With a second person inside cabin to tighten nuts, latch forward doors. Install hardware securing upper retainer and B409-5 gusset to cabin. Remove tape and wipe off excess sealant with cheesecloth wet with lacolene.
8. Remove door and hinge assembly. Run a bead of B270-26 sealant along entire edge of tape line. Install hardware securing side retainer and D805-2 restraint to cabin. Remove tape and wipe off excess sealant with cheesecloth wet with lacolene.
9. Reinstall hinge assembly, and install door assembly per § 27-10 Part C.
10. Ensure all fasteners are tight. Wipe off excess sealant with cheesecloth wet with lacolene.
11. Allow sealant to dry according to manufacturer's instruction.
12. Remove protective paper or film from inside and outside of the windshield.
13. Repeat steps to install opposite-side windshield, as required.
14. Install B295-1 clip and yaw string per § 27-33 Part B.

27-31 Standard (Acrylic) Windshield Installation (continued)**F. Replacement****NOTE**

Prior to installation, if not previously accomplished, tape protective paper or film to the inside and outside of the windshield to prevent damage.

1. Verify sealant has been removed from cabin and parts.
2. Cleco retainers to frames, checking for proper alignment. Remove retainers, except C238-27 or C238-28 (side) retainer.
3. Install A228 (upper) and C228 (lower) door hinge assemblies, and install forward door assemblies for cabin structure support during windshield installation.
4. Lay out masking tape on frames to identify location for windshield edge (estimate edge where side retainer is clecoed to frame). Hold oversized windshield in place by hand and verify it overlaps masking tape on all frames and retainer. When satisfied with alignment, lay out masking tape on windshield for trimming.

WARNING

Review appropriate Safety Data Sheet (SDS) when working in proximity to hazardous materials. Specific recommendations for use of personal protective equipment are located in the SDS.

5. A band saw with a blade containing at least 24 teeth per inch is recommended for initial trimming. Tape cardboard to band saw table to prevent scratching of windshield. Trim windshield carefully to prevent binding of saw blade and cracking windshield. Finish initial cut using an orbital sander, as required.
6. Hold windshield in place and check for fit. Re-trim as necessary.
7. After windshield is fitted, use sanding block with 100-grit paper to smooth edges. Finish edge and bevel corners using a triangular machinist's scraping tool. Verify all edges are clean and free of notches.
8. Remove trimming debris from windshield and cabin.
9. Install windshield per § 27-31 Part E.

27-32 Impact-Resistant (Polycarbonate) Windshield Installation

A. Description

The polycarbonate windshield installation is similar to the acrylic windshield installation, but the windshields fasten to the door and windshield frames via small stainless steel straps.

While polycarbonate has superior strength and flexibility properties when compared with acrylic, it is also more susceptible to ultraviolet (UV) degradation, and has a low scratch resistance. A hardcoat is applied during manufacturing to protect against UV damage and scratching, however, further effort must be made by the operator to maximize windshield service life. Follow instructions closely to avoid scratching windshield during cleaning (refer to § 23-10 Part B). Exposure to incompatible cleaning agents or solvents can result in embrittlement or crazing. Use a cabin cover when parking helicopter outdoors, or store helicopter in hanger when possible.

B. Cleaning

Refer to § 23-10 Part B for cleaning windshield.

C. Inspection

Inspect both windshields for cracks and crazing adjacent to retainers per Figure 27-3. Also inspect areas adjacent to fasteners and stainless steel straps for cracks and crazing. If cracks exceed these limits, replace damaged windshield per § 27-31 Part F.

Inspect windshields for any significant discoloration or cloudiness. Minor defects or imperfections that do not impair pilot visibility or indicate impending structural failure are acceptable.

D. Removal

1. Perform § 27-31 Part D steps 1 thru 3.
2. Support windshield. With a second person inside cabin to remove nuts and washers, latch forward doors. Remove hardware securing G367 ties and straps to windshield near center bow (all other hardware installed in windshield may remain in place during windshield removal). Taking care not to bend ties and straps, remove sealant as required, and remove ties & straps from windshield.
3. Remove hardware securing C238-29 (upper) retainer, B409-5 gusset, D805-2 restraint, C366-5 bracket, C366-8 retainer, C367 (lower) retainers, B295-2 clip with trim string, C367-12 stiffener, and C367-10 retainer to cabin and remove parts. Taking care not to bend ties and straps, remove windshield.
4. Remove sealant from cabin and parts.
5. If windshield is to be reinstalled, remove sealant from windshield but leave hardware and G367 ties, straps, pads, and tabs installed. If replacing windshield, remove hardware and, without deforming, remove G367 ties, straps, pads, and tabs, as required.
6. Repeat steps to remove opposite-side windshield, as required.

27-32 Impact-Resistant (Polycarbonate) Windshield Installation (continued)**E. Installation****NOTE**

Prior to installation, if not previously accomplished, tape protective paper or film to the inside and outside of the windshield to prevent damage.

NOTE

Inspect condition of G367 ties, straps, pads, and tabs to be installed. Verify no obvious damage, deformation, or stretching. If windshield is being replaced due to bird strike or other impact which could deform ties, straps, pads, or tabs, replacement of these items is recommended.

NOTE

Refer to R44 Illustrated Parts Catalog Chapter 52. Note location of G367 ties, straps, pads, and tabs on work table or by marking on tape at fasteners to facilitate installation.

1. Verify sealant has been removed from cabin, parts, and windshield.
2. Position windshield on helicopter and cleco G367 ties, straps, tabs, and retainers to frames. Also, cleco G367 ties, straps, and tabs to windshield at center bow, if drilled.
3. Install A228 (upper) and C228 (lower) door hinge assemblies. Install forward door assemblies for cabin structure support during windshield installation.
4. If windshield is drilled and has hardware, G367 ties, straps, pads, and tabs installed:
 - a. With a second person inside cabin to tighten nuts, latch forward doors. Remove clecoes and install hardware securing G367 ties and straps to windshield at center bow; special torque screws per § 23-33.
 - b. Attach 1/2"-wide masking tape to windshield along edge of retainers to catch sealant squeeze-out during retainer installation.
 - c. Remove C367-10 (center) retainer. Run a bead of B270-26 sealant along entire edge of tape line. Install hardware securing center retainer and C367-12 stiffener (do not install B295-2 clip) to cabin; special torque screws per § 23-33. Remove tape and wipe off excess sealant with cheesecloth wet with lacolene.
 - d. Perform § 27-31 Part E steps 6 thru 13.
 - e. Paint (or touch up) windshield trim per § 27-32 Part G.
 - f. Install B295-2 clip and yaw string per § 27-33 Part B.

27-32 Impact-Resistant (Polycarbonate) Windshield Installation (continued)**E. Installation (continued)**

5. Align G367 ties and straps perpendicular to retainers within 2°. Install C367-12 stiffener and special torque screws per § 23-33. Match drill #40 pilot holes through windshield and install clecos.
6. At center bow:
 - a. Remove C367-12 stiffener and C367-10 (center) retainer. Remove G367 ties and straps and expand pilot holes to 0.169–0.175 inch diameter holes thru windshield. Finish holes with reamer; deburr back side of holes using plastic razor. Clean up debris.
 - b. Apply B270-26 sealant to G367 tabs and pads and position on windshield. Run a bead of B270-26 sealant along entire edge of windshield. Install hardware securing center retainer, C367-12 stiffener (do not install B295-2 clip) to cabin. Special torque screws per § 23-33.
 - c. With a second person inside cabin to tighten nuts, latch forward doors and install hardware securing G367 ties and straps to windshield; special torque screws per § 23-33. Wipe off excess sealant with cheesecloth wet with lacolene.
7. At lower retainers:
 - a. Remove C367 (lower) retainers. Remove G367 straps and expand pilot holes to 0.169–0.175 inch diameter holes thru windshield. Finish holes with reamer; deburr back side of holes using plastic razor. Clean up debris.
 - b. Apply B270-26 sealant to G367-12 tabs and position on windshield. Run a bead of B270-26 sealant along entire edge of windshield. With a second person inside cabin to tighten nuts, latch forward doors, and install hardware securing lower retainers, C366-8 retainer, and C366-5 bracket to cabin. Install hardware securing G367 straps to windshield; special torque screws per § 23-33. Wipe off excess sealant with cheesecloth wet with lacolene.
8. At upper retainer:
 - a. Remove C238-29 (upper) retainer. Remove G367 straps and expand pilot holes to 0.169–0.175 inch diameter holes thru windshield. Finish holes with reamer; deburr back side of holes using plastic razor. Clean up debris.
 - b. Run a bead of B270-26 sealant along entire edge of windshield. With a second person inside cabin to tighten nuts, latch forward doors, and install hardware securing upper retainer and B409-5 gusset to cabin. Install hardware securing G367 straps and ties to windshield; special torque screws per § 23-33. Wipe off excess sealant with cheesecloth wet with lacolene.

27-32 Impact-Resistant (Polycarbonate) Windshield Installation (continued)**E. Installation (continued)**

9. At door frame:
 - a. Remove door and hinge assembly. Remove G367 straps and expand pilot holes to 0.169–0.175 inch diameter holes thru windshield. Finish holes with reamer; deburr back side of holes using plastic razor. Clean up debris.
 - b. Run a bead of B270-26 sealant along entire edge of windshield. Install hardware securing side retainer and D805-2 restraint to cabin. Install hardware securing G367 straps and ties to windshield; special torque screws per § 23-33. Wipe off excess sealant with cheesecloth wet with lacolene.
10. Reinstall hinge assembly, and install door assembly per § 27-10 Part C.
11. Ensure all fasteners are tight. Wipe off excess sealant with cheesecloth wet with lacolene.
12. Allow sealant to dry according to manufacturer's instruction.
13. Repeat steps to install opposite-side windshield, as required.
14. Paint (or touch up) windshield trim per § 27-32 Part G.
15. Install B295-2 clip and yaw string per § 27-33 Part B.

F. Replacement**NOTE**

Do not use this procedure to upgrade acrylic to polycarbonate windshields.

1. Perform § 27-31 Part F steps 1 thru 4.

WARNING

Review appropriate Safety Data Sheet (SDS) when working in proximity to hazardous materials. Specific recommendations for use of personal protective equipment are located in the SDS.

2. A band saw with 20°–30° clearance angle, 0–5° rake angle, 600–1000 m/min rotation speed, and 1.5–4 mm tooth spacing is recommended for initial trimming. Tape cardboard to band saw table to prevent scratching of windshield. Trim windshield carefully to prevent binding of saw blade and cracking windshield. Finish initial cut using an orbital sander, as required.
3. Hold windshield in place and check for fit. Re-trim as necessary.
4. After windshield is fitted, use sanding block with 100-grit paper to smooth edges. Verify all edges are clean and free of notches.
5. Remove trimming debris from windshield and cabin.
6. Install windshield per § 27-32 Part E.

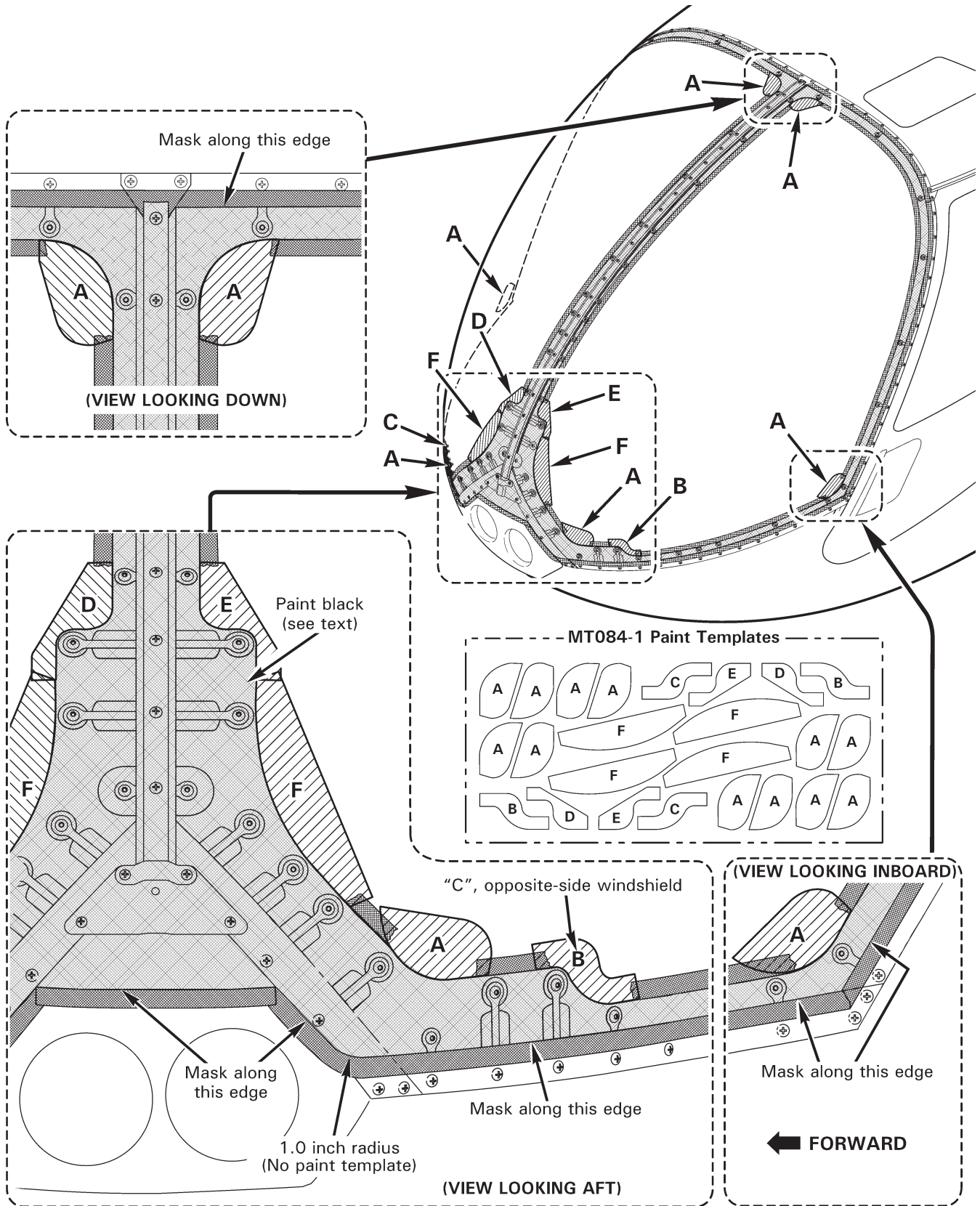

FIGURE 27-4 PAINT TEMPLATE LAYOUT

27-32 Impact-Resistant (Polycarbonate) Windshield Installation (continued)**G. Trim Paint**

1. Remove B295-2 clip and yaw string from bow assembly and reinstall screw.
2. Trim any excess sealant around perimeter of windshield using plastic razor blades; remove sealant residue using cheesecloth wet with lacolene.
3. Clean surface of windshield to be masked for paint using cheesecloth wet with lacolene.

NOTE

Cleaning surface of windshield prior to masking will prevent paint from "bleeding," or seeping, under tape.

4. Refer to Figures 27-4 and 27-5. Using 3M vinyl tape (or equivalent), apply masking ("Tape 1" and "Tape 2") to windshield as shown. Apply MT084-1 paint templates on windshield as shown.
5. Refer to Figure 27-4. Using 3M vinyl tape (or equivalent), apply masking to windshield retainer edges, area near landing lights, and between MT084-1 paint templates as shown.
6. Protect windshield and cabin from paint overspray.
7. Using 320-grit sandpaper and scotch-brite, lightly scuff surfaces to be painted. Avoid damaging masking edges; replace any damaged masking per steps 4 and 5 as required.
8. Remove debris using compressed air.
9. Clean scuffed surfaces to be painted using a lint-free cloth wet with Final Klean 3909S.
10. Conversion coat bare aluminum per § 23-51, as applicable.
11. Refer to § 23-77. Apply black paint to windshield trim prepared surfaces per Figure 27-4.
12. Allow paint to cure. Remove MT084-1 paint templates and masking. Clean windshield per § 23-10 Part B.
13. Install B295-2 clip and yaw string per § 27-33 Part B.

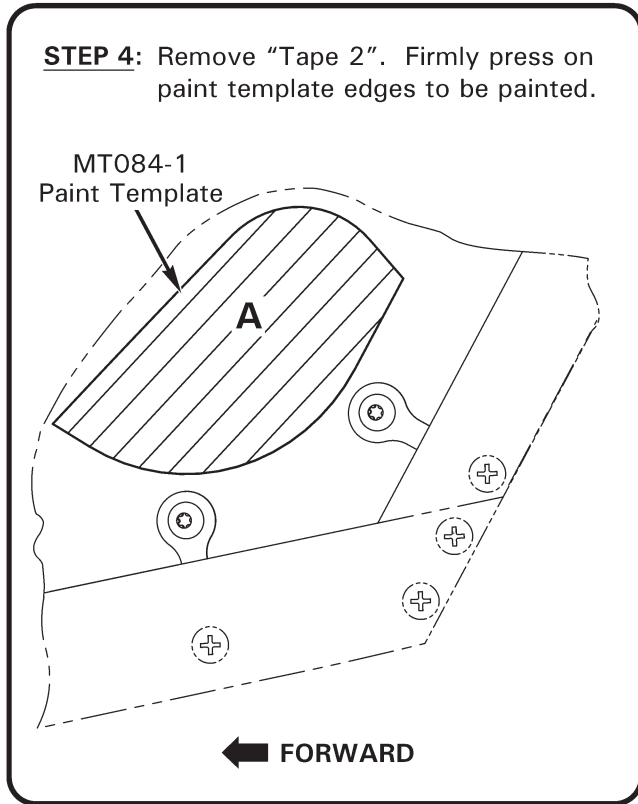
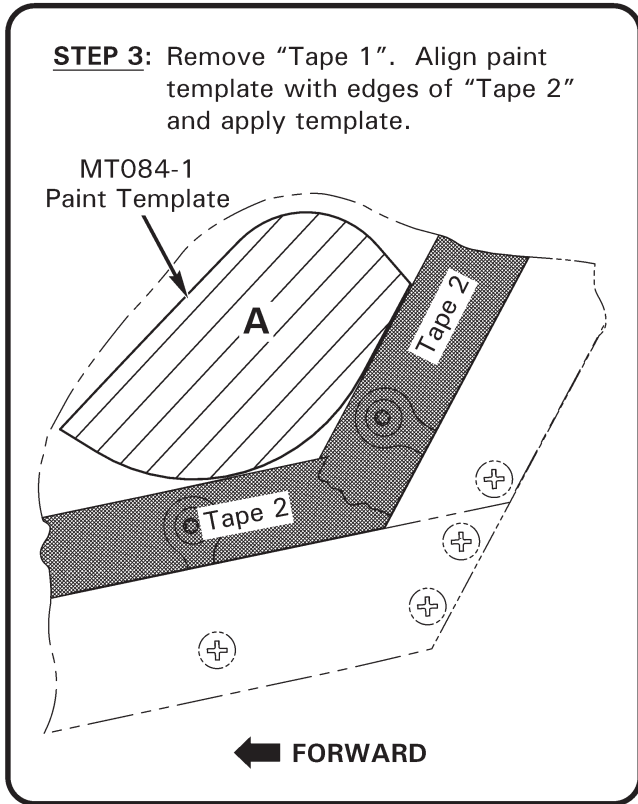
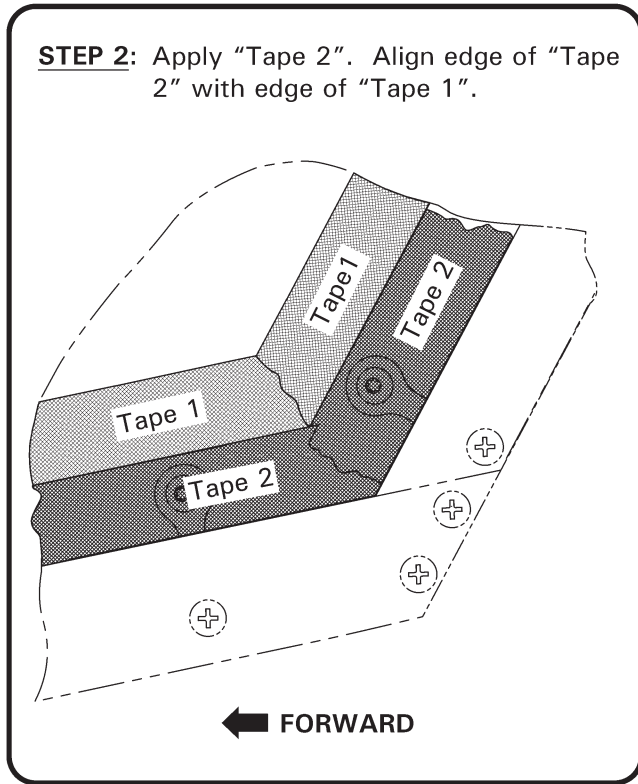
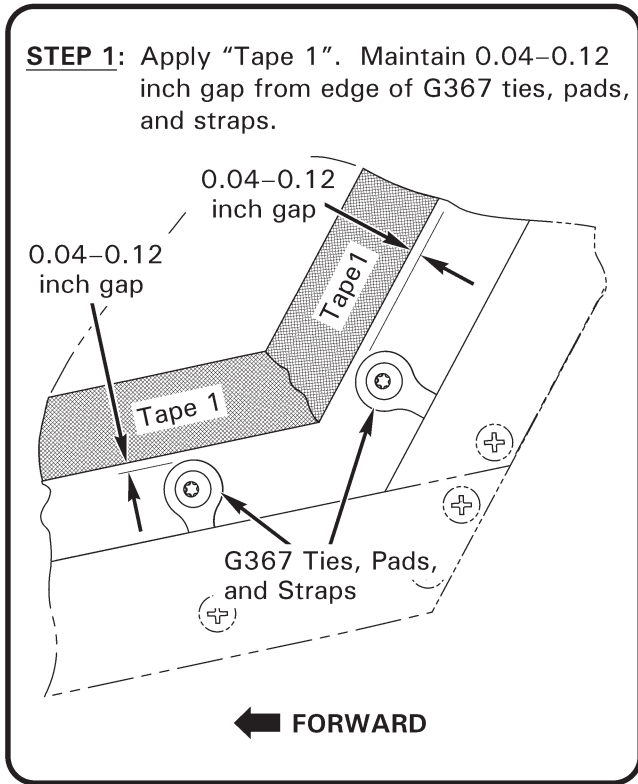

FIGURE 27-5 PAINT TEMPLATE LAYOUT PROCESS

27-33 Yaw String**A. Removal**

Remove screw securing B295-1 or B295-2 clip; remove clip and yaw string.

B. Installation

1. Locate 7th screw (8th screw for helicopters equipped with 10 hole console assemblies) up from bottom of C367-12 stiffener and remove screw.
2. Position yaw string on stiffener just above hole location; install screw securing B295-1 or -2 clip, finger tight. Verify 3 inches string, each side of clip; special torque screw per § 23-33. Cut replacement string to 3 inches from each side of clip, if applicable.

Intentionally Blank

CHAPTER 28**MAIN ROTOR**

<u>Section</u>	<u>Title</u>	<u>Page</u>
28-00	Description	28.1
28-10	Main Rotor Blades	28.1
28-11	Blade Boots	28.7
28-12	Filling Pitch Bearing Housing	28.9
28-20	Main Rotor Hub	28.10
28-21	Bearing Replacement	28.12
28-22	Inspection and Repair	28.13
28-30	Main Rotor Assembly	28.17
28-31	Journal and Shim Calculations	28.17
28-32	Adjusting Hinge Friction	28.21
28-33	Shifting the Main Rotor Hub	28.22
28-34	Drilling Main Rotor Hub Bolts	28.22
28-35	Static Balance	28.25
28-40	Inspection of Main Rotor Blades	28.29
28-41	Scratches and Corrosion on Blade Skins and Doublers	28.30
28-42	Dents and Local Deformations	28.33
28-43	Root Fitting Damage	28.34
28-44	Voids	28.37
28-50	Repair of Main Rotor Blades	28.39
28-51	Trimming	28.41
28-52	Painting	28.41
28-60	Main Rotor Blade Tip Maintenance	28.43

Intentionally Blank

CHAPTER 28

MAIN ROTOR

28-00 Description

The main rotor has two all-metal blades mounted to the hub by coning hinges. The hub is mounted to the shaft by a teeter hinge. The coning and teeter hinges use self-lubricated bearings. Droop stops for the main rotor blades provide a teeter hinge friction restraint which normally prevents the rotor from teetering while starting or stopping. Pitch change bearings for each blade are enclosed in a housing at the blade root. The housing is filled with oil and sealed with an elastomeric boot. Each blade has a thick stainless steel spar at the leading edge which is resistant to corrosion and erosion. The skins are bonded to the spar approximately one inch aft of the leading edge. Blades must be refinished if the paint erodes to bare metal at the skin-to-spar bond line. Bond may be damaged if bond line is exposed.

28-10 Main Rotor Blades**WARNING**

Due to potentially destructive results, use of blade tape (anti-erosion tape) is prohibited.

A. Removal

Refer to Figure 28-1. Four people will be required to remove the blades. One person must support the blade approximately 2/3 its length from the root while another supports the root and removes or installs the attachment bolt.

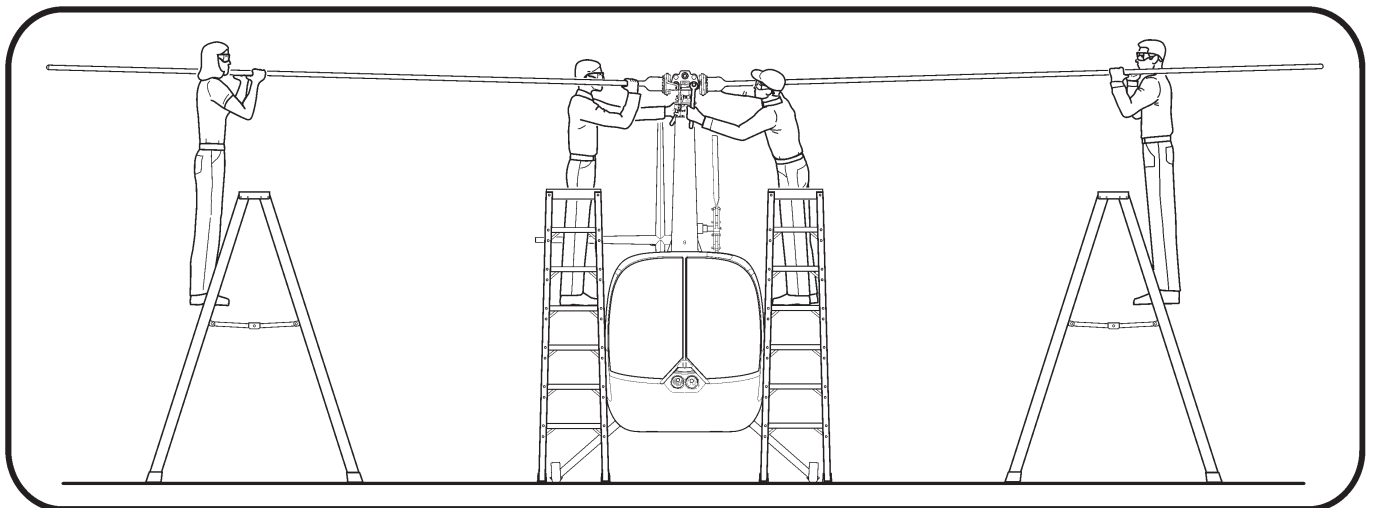

FIGURE 28-1 SUPPORTING MAIN ROTOR BLADES DURING BLADE REMOVAL OR INSTALLATION

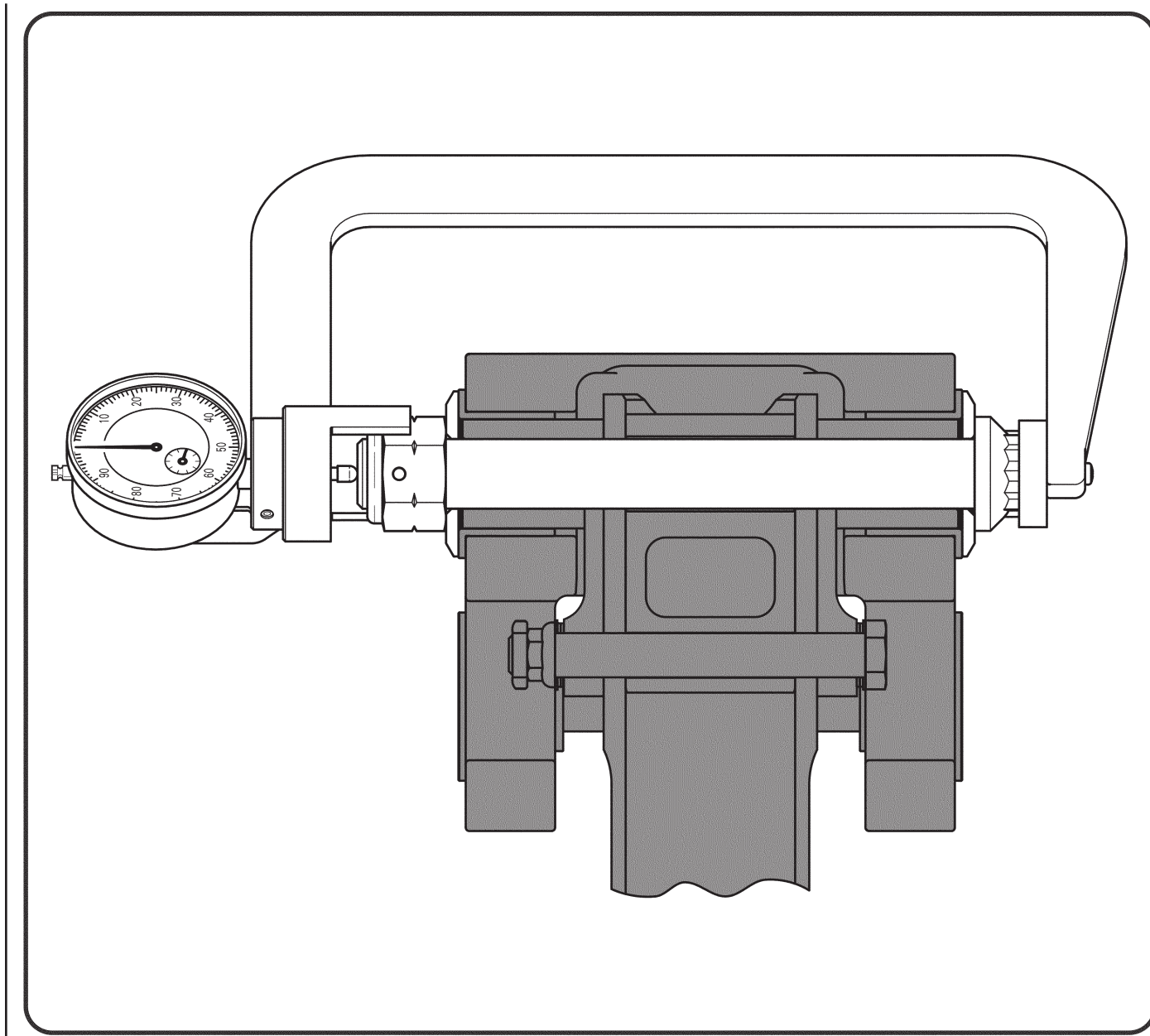

FIGURE 28-2 MEASURING BOLT STRETCH (SHOWN ON TEETER BOLT, BLADES REMOVED)

28-10 Main Rotor Blades (continued)**A. Removal (continued)**

1. Mark one main rotor blade and its corresponding hub location, pitch link, and retaining nut & bolt with "X" using a marker or grease pencil. Mark opposite blade and its hub location, pitch link, and retaining nut & bolt with "O".
2. Measure and record coning hinge axial gaps per Figure 28-7.
3. Remove hardware securing main rotor pitch links to blade pitch horns.
4. Remove cotter pins and loosen blade coning hinge retaining nuts until finger tight.

CAUTION

After removing one blade, support installed blade in a level position until it is removed.

5. Remove nut, thrust washer, and trailing-edge shims (if used) from one blade. Cone blade as required to position spindle tusk off of droop stop. Supporting blade at root, rotate pitch horn down, and remove hinge bolt and thrust washer.

CAUTION

Do not drop journals (inside hub bearings) which can slide out when removing blade bolt.

NOTE

Blade installation hardware is specific to each blade, each blade's leading and trailing edge, and each blade's location in hub. It is good practice after blade removal to install hardware in hub finger tight exactly as removed.

6. Place blade on a cushioned surface to prevent damage to skins.
7. Remove opposite blade per steps 5 and 6.

28-10 Main Rotor Blades (continued)**B. Installation****CAUTION**

R44-series helicopters must replace C016-2 and C016-5 main rotor blades with C016-7 main rotor blades per US Airworthiness Directive 2014-23-16. Installing C016-7 blades on carbureted R44 helicopters requires verifying certain components are installed or retrofitted per R44 SL-37 (current revision).

1. Check teeter hinge friction and adjust as required per § 28-32.
2. If coning hinge axial gap recorded during blade removal was beyond tolerance, or if corresponding hub bearing(s) or spindle was replaced, perform coning hinge journal and shim calculation per § 28-31.
3. Level hub and insert journals in hub bearings. Install thrust washer on blade bolt.
4. Insert main rotor blade spindle in hub and align spindle and journal bores. Cone blade as required to position tusk off of droop stop. Rotate pitch horn down and install hinge bolt at leading-edge side.

NOTE

A bolt may be inserted from trailing-edge side to align spindle and journal bores (it is pushed out as coning hinge bolt is installed).

5. Install trailing-edge shims (if used) and thrust washer. Apply light coat A257-9 anti-seize to bolt threads and nut face. Install nut finger tight.

NOTE

Do not allow anti-seize to contact journals, shims, or hub bearing areas. These areas must be clean and dry.

CAUTION

After installing one blade, support blade in a level position until opposite blade is installed.

6. Install opposite blade per steps 3 thru 5.
7. Tighten nut on coning hinge bolt until journals and thrust washer are firmly seated. Loosen nut until both thrust washers can be freely rotated.
8. Refer to Figure 28-2. Install MT122-6 main rotor bolt stretch tool on hinge bolt. Zero dial indicator by rotating dial face and lock dial. Remove tool.

28-10 Main Rotor Blades (continued)

B. Installation (continued)

9. Using wrenches with at least 600 ft-lb torque capacity, tighten nut until drilled holes in nut and bolt align. Install MT122-6 tool and measure bolt stretch:
 - a. If bolt stretch is between 0.020–0.022 inch, remove tool and install a new cotter pin wet with approved primer (chromate primer preferred).
 - b. If bolt stretch is not between 0.020–0.022 inch, remove old nut and old bolt and install a new bolt and a new nut. Stretch new bolt per § 23-33, and drill new nut and bolt per § 28-34. Install a new cotter pin wet with approved primer (chromate primer preferred).

WARNING

Do not under-stretch or over-stretch teeter or coning hinge bolts to obtain proper clamping force. Under-stretching or over-stretching can cause failure.

10. Install hardware securing main rotor pitch link to pitch horn. Standard torque hardware per § 23-32 and torque stripe per Figure 2-1.

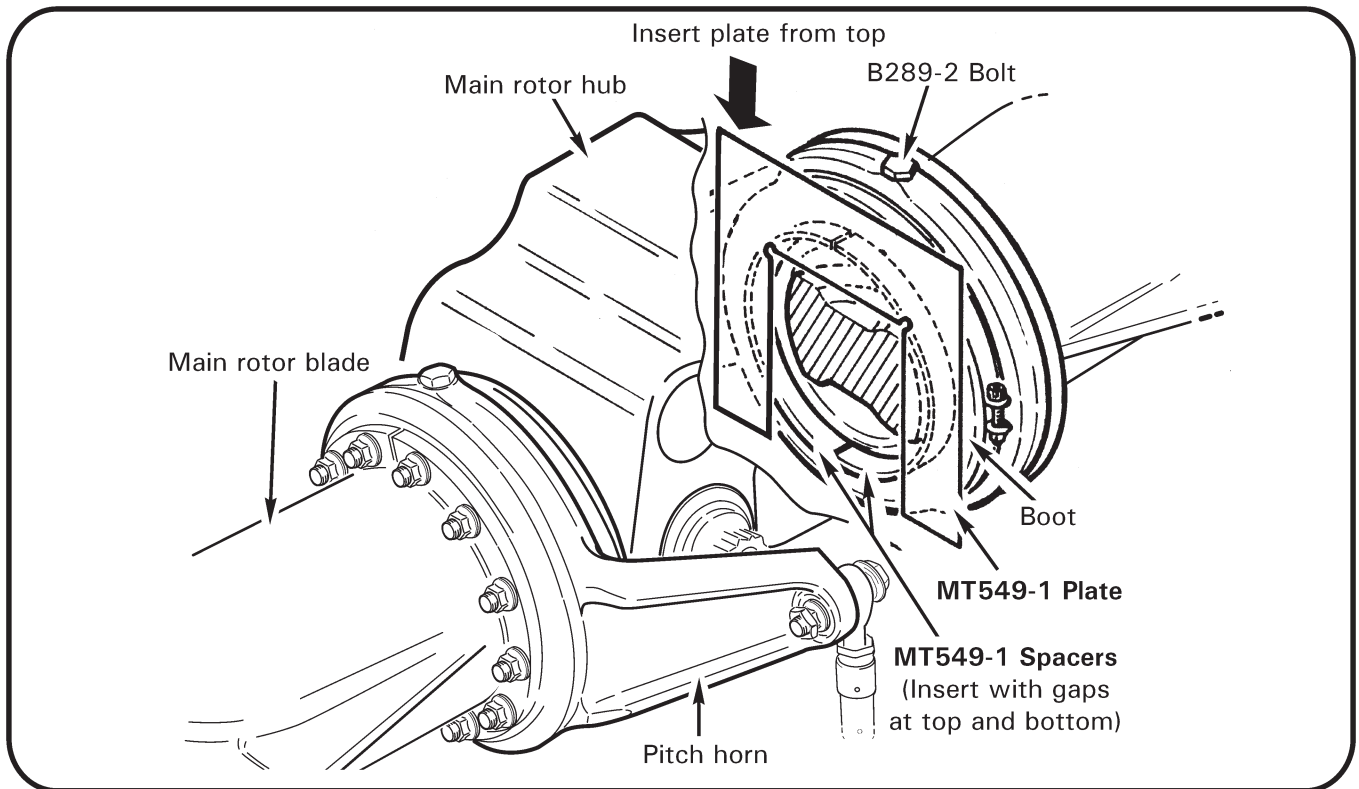

FIGURE 28-3 ADJUSTING BOOT CLEARANCE

28-10 Main Rotor Blades (continued)**B. Installation (continued)**

11. Perform steps 7 thru 10 on opposite blade. If different blades are being installed or if blade pitch bearing housing has recently been serviced perform steps 12 thru 16.
12. Position cyclic and collective controls mid-travel and apply frictions.
13. Refer to Figure 28-3. Insert two MT549-1 spacers between hub and blade boot with gaps at top and bottom. Spacers should fit in recess of boot. Hold spacers in place against boot and insert MT549-2 plate from top between hub and spacers. Push plate down until it contacts spindle.
14. Remove bottom B289-2 bolt from pitch horn and allow oil to flow. Place a finger over hole as soon as oil flow decreases to a drip to prevent air from being sucked inside pitch bearing housing.
15. Remove finger from hole and quickly install bolt. Special torque bolt per § 23-33 and torque stripe per Figure 2-1.
16. Remove plate and spacers. Repeat on opposite blade.
17. Track and balance main rotor blades per § 10.230.

CAUTION

When fitting a replacement main rotor blade(s), remove both main rotor blade tip covers after initial run-up and clean out debris.

28-11 Blade Boots**A. Removal**

1. Remove main rotor blades per § 28-10.
2. Place a suitable drain container below pitch horn. Remove two B289-2 bolts and drain fluid.
3. Remove outer boot clamp and hold boot back to expose inner boot clamp. Remove inner clamp and peel boot from spindle. Boot inner portion may be sealed to spindle with B270-1 sealant.
4. As required, use a plastic scraper and vacuum cleaner to remove old B270-1 sealant from spindle area to be covered by boot inner lip. Avoid contaminating spindle bearings with old sealant.

WARNING

Use only plastic scrapers to remove old sealant; chemical removal is prohibited.

B. Installation**NOTE**

C156-1 (Black) blade boots are standard; C156-2 (grey) boots are optional for use in sub-freezing temperatures.

1. Visually inspect and verify boot is undamaged. Carefully stretch new boot over spindle.
2. Solvent-clean surfaces clamped by boot inner lip. Properly position boot inner lip; install C165-1 (inner) clamp assembly and tighten clamp to 2.850 ± 0.005 inch outside diameter. Rotate spindle and verify adequate clearance between clamp assembly and pitch horn.

NOTE

When installing inner clamp, ensure that shoulder of boot inner lip is not wedged beneath clamp or clamp may loosen in service. Inspect boot interior and verify no cuts or punctures.

3. Stretch boot outer lip over pitch horn flange. Rotate spindle and align pitch horn bolt hole with spindle bolt hole per Figure 28-4. Install C165-2 (outer) clamp assembly and tighten clamp. Verify security.
4. Fill root fitting per § 28-12.

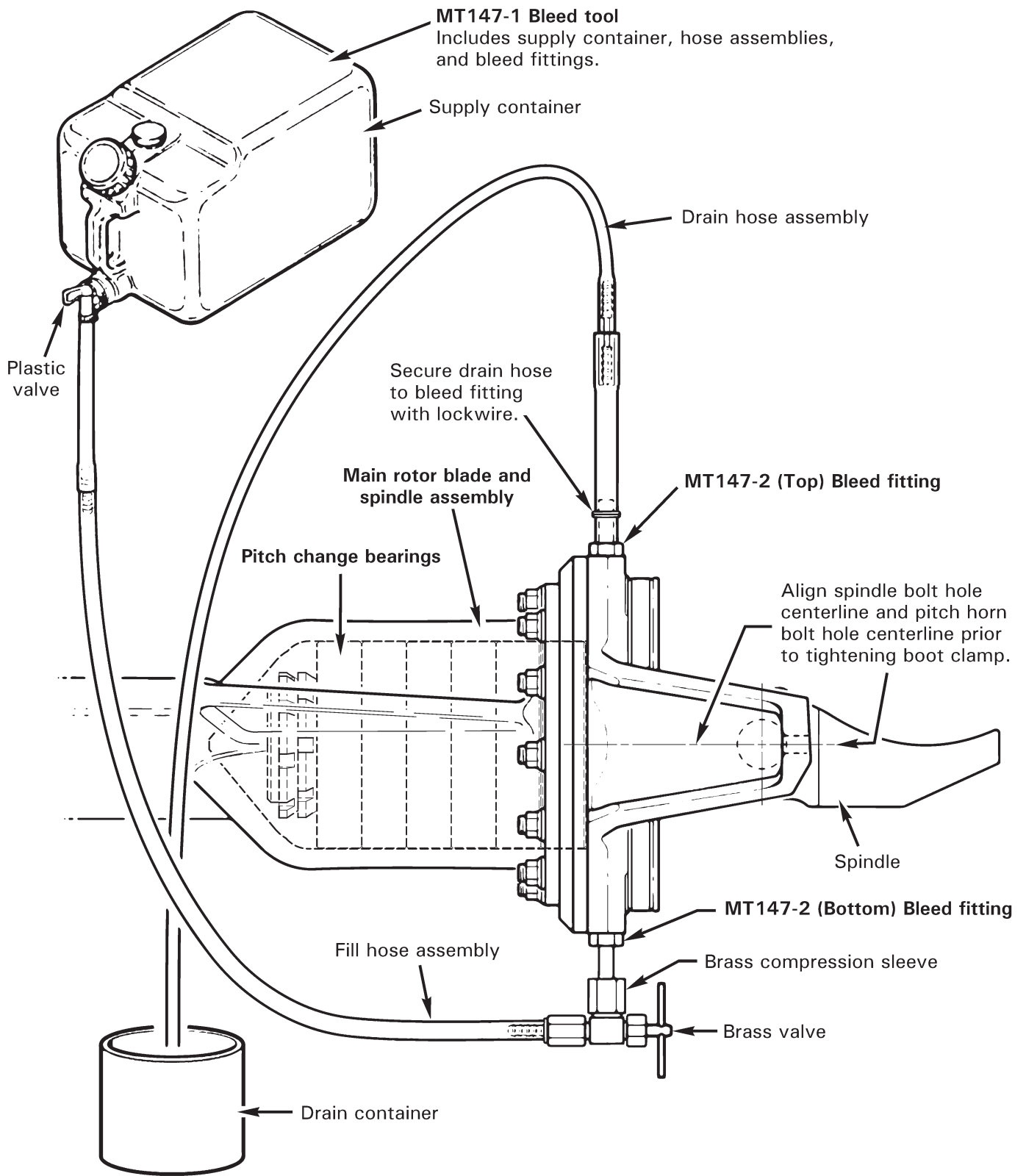

FIGURE 28-4 FILLING PITCH BEARING HOUSING

28-12 Filling Pitch Bearing Housing

NOTE

MT147-1 Main rotor blade spindle air bleed tool includes supply container, hose assemblies, and bleed fittings.

WARNING

Refer to Safety Data Sheets (SDS) and observe precautions when working in proximity to hazardous materials.

1. Remove main rotor blades per § 28-10.
2. Refer to Figure 28-4. Place a suitable drain container below main rotor pitch horn. Remove two B289-2 bolts from pitch horn and drain fluid.
3. Install MT147-2 bleed fittings into pitch horn openings. Attach drain hose assembly to (top) bleed fitting, secure with two wraps of lockwire. Position drain hose into drain container.
4. Place supply container with sufficient A257-4 fluid approximately 3 feet above spindle. Route fill hose assembly into drain container and open brass valve. Open supply container plastic valve and purge air from fill hose. Close valves.
5. Connect brass valve to (bottom) bleed fitting by tightening brass compression sleeve.
6. Open valves and fill spindle housing until no air bubbles are visible in drain hose assembly. Massage spindle boot, oscillate spindle, and raise blade tip up & down to remove trapped air.
7. Remove drain hose assembly and (top) bleed fitting, and install B289-2 bolt. Roll the blade over. After five minutes, inspect the boot for leaks. If no leaks are found, close valves, remove fill hose assembly brass valve and (bottom) bleed fitting, and install other bolt.
8. Special torque B289-2 bolts per § 23-33 and torque stripe per Figure 2-1.
9. Repeat steps for opposite blade.

28-20 Main Rotor Hub**A. Removal**

1. Remove main rotor blades per § 28-10.
2. Refer to Figure 28-7. Mark rotor hub using a grease pencil, tape, or soft marker as follows:
 - a. Indicate nut side of teeter bolt.
 - b. Indicate chord arm side of drive shaft.
3. If same hub will be installed, measure teeter hinge friction per Figure 28-9 and record value.
4. Remove cotter pin, nut, C152 thrust washers, C117 shims, C106 journals, and bolt. Rotate hub as required and remove hub. Do not drop thrust washers or journals.
5. Reinstall bolt, thrust washers, shims, journals, and nut in rotor hub exactly as removed.

CAUTION

Main rotor chordwise balance is adjusted using C106 journals and C117 shims. If assembly stack-up is altered, an out-of-balance condition can occur.

B. Installation

1. Clean and dry teeter hinge hardware using approved solvent per § 23-70. Inspect journals and thrust washers for chipping of chrome plating, corrosion, and/or wear grooves extending through chrome plating (0.0006 inch maximum wear). Replace journal or thrust washer if any of these conditions exist.
2. If teeter hinge friction recorded during hub removal was less than 5 ft-lb or more than 20 ft-lb, if teeter hinge hub bearing(s) was replaced, or if previous installation information is unavailable, perform teeter hinge journal and shim calculation per § 28-31.
3. Refer to Figure 28-7. Line up mark on hub with chord arm on drive shaft. Install teeter hinge bolt, thrust washers, shims, and journals (if previous installation information is available, install parts exactly as removed).

28-20 Main Rotor Hub (continued)**B. Installation (continued)**

4. Coat nut face and bolt threads with A257-9 anti-seize compound, install and tighten nut, then loosen nut until both thrust washers can be freely rotated. Ensure journals do not “pinch” droop stops and fully contact drive shaft.

WARNING

Do not allow anti-seize compound to contaminate drive shaft, journals, shims, or thrust washer inner faces. Contamination prevents proper joint clamp-up and may cause failure.

5. Refer to Figure 28-2. Install MT122-6 main rotor bolt stretch tool on teeter bolt. Zero dial indicator by rotating dial face and lock dial. Remove tool.
6. Using wrenches with at least 600 ft-lb torque capacity, tighten nut until drilled holes in nut and bolt align. Install MT122-6 tool and measure bolt stretch:
 - a. If bolt stretch is between 0.020–0.022 inch, remove tool and verify correct teeter hinge friction per § 28-32. Adjust teeter hinge friction as required.
 - b. If bolt stretch is not between 0.020–0.022 inch, remove old nut and old bolt and install a new bolt and a new nut. Stretch new bolt per § 23-33 and verify correct teeter hinge friction per § 28-32. Adjust teeter hinge friction as required. Drill new nut and bolt per § 28-34.

WARNING

Do not under-stretch or over-stretch teeter or coning hinge bolts to obtain proper clamping force. Under-stretching or over-stretching can cause failure.

7. Install a new cotter pin wet with approved primer (chromate primer preferred; refer to § 23-75.

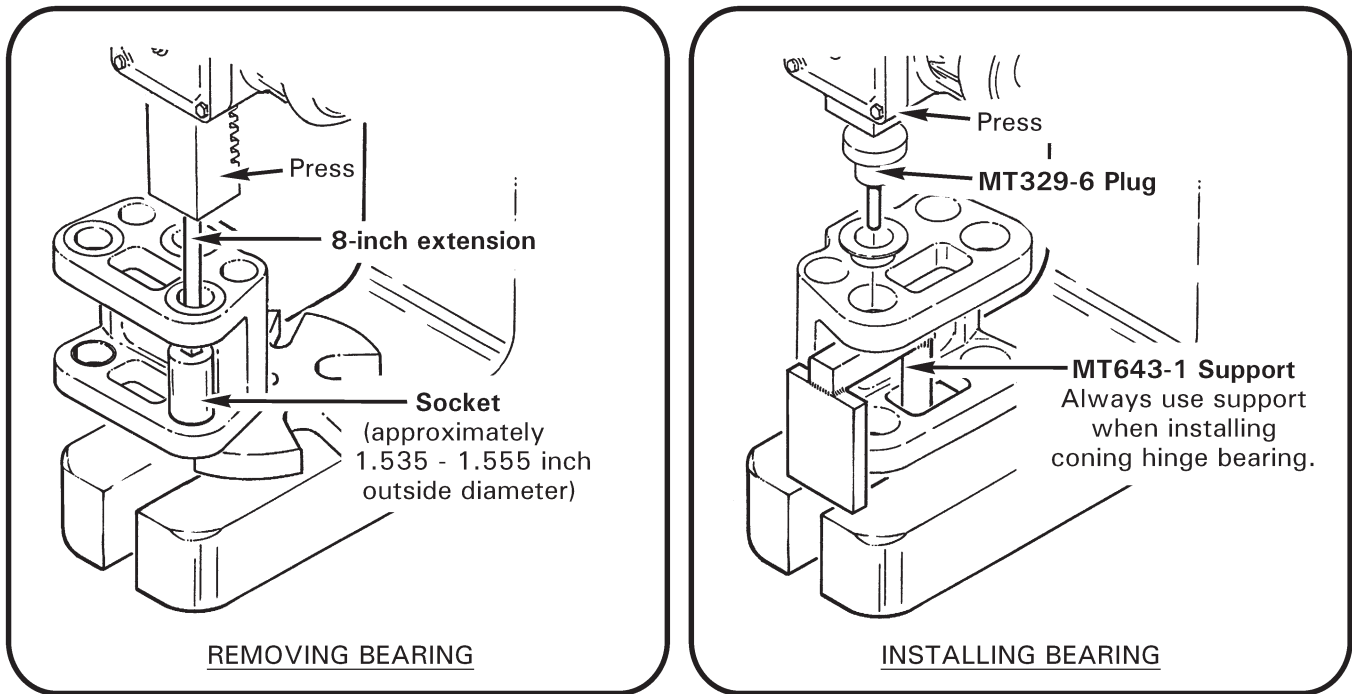

FIGURE 28-5 MAIN ROTOR HUB BEARING REPLACEMENT

28-21 Bearing Replacement

1. Remove main rotor hub per § 28-20.
2. Refer to Figure 28-5. Verify tooling surfaces are smooth to avoid damaging hub and bearings. Press bearing(s) from hub using a socket (approximately 1.535–1.555 inch outside diameter) and an 8-inch extension; alternately, press bearing(s) from hub using MT329-6 (Rev H or subsequent) with MT329-10 tube.
3. Visually inspect hub bearing bore(s) per § 28-22 step 3a.

NOTE
Do not allow primer to contact bearing's Teflon liner.

4. Verify bearing mating surfaces are smooth and clean and apply light coat of approved primer (chromate primer preferred; refer to § 23-75). If visible, orient coning hinge bearing's Teflon liner seam toward top of hub. While primer is wet, press in new bearing using MT329-6 plug (and MT643-1 support if replacing coning hinge bearing) until bearing flange is completely seated against hub.
5. Using a syringe, seal between bearing's outboard flange and hub and bearing's inboard edge and hub with small fillet of approved primer.

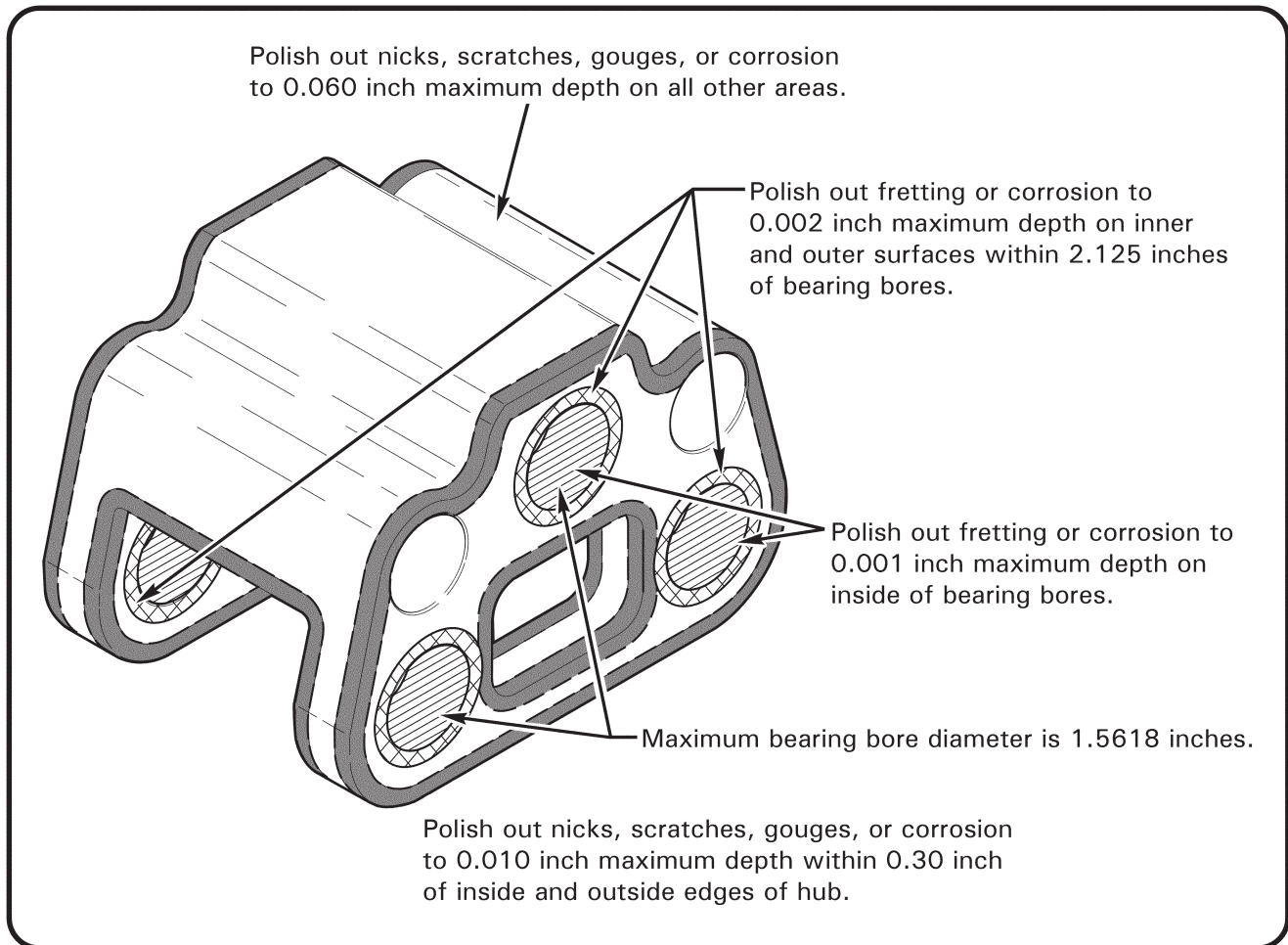

FIGURE 28-6 MAIN ROTOR HUB REPAIR LIMITS

28-22 Inspection and Repair

1. Remove main rotor hub bearings per § 28-21 steps 1 thru 4.
2. Remove hub paint by plastic or baking soda media blasting.
3. Refer to Figure 28-6 If required, polish surfaces using 320-grit or finer aluminum-oxide abrasive paper to 0.25 inch minimum blend radius.
 - a. Visually inspect hub bearing bores and verify no scoring, scratches, or other obvious damage. Polish out fretting or corrosion to 0.002 inch maximum depth on inner and outer surfaces within 2.125 inches of bearing bores. Polish out fretting or corrosion to 0.001 inch maximum depth on inside of bearing bores; maximum bearing bore diameter is 1.5618 inches.
 - b. Visually inspect all other areas of hub for obvious damage. Polish out nicks, scratches, gouges, or corrosion to 0.010 inch maximum depth within 0.30 inch of inside and outside edges of hub. Polish out nicks, scratches, gouges, or corrosion to 0.060 inch maximum depth on all other areas.

28-22 Inspection and Repair (continued)

4. Fluorescent penetrant inspect hub per § 23-42.
5. Prime hub per § 23-60.
6. Install bearings per § 28-21 steps 4 and 5.
7. Mask bearings and topcoat hub assembly per § 23-60.
8. When top coat has sufficiently cured, remove masking.

Intentionally Blank

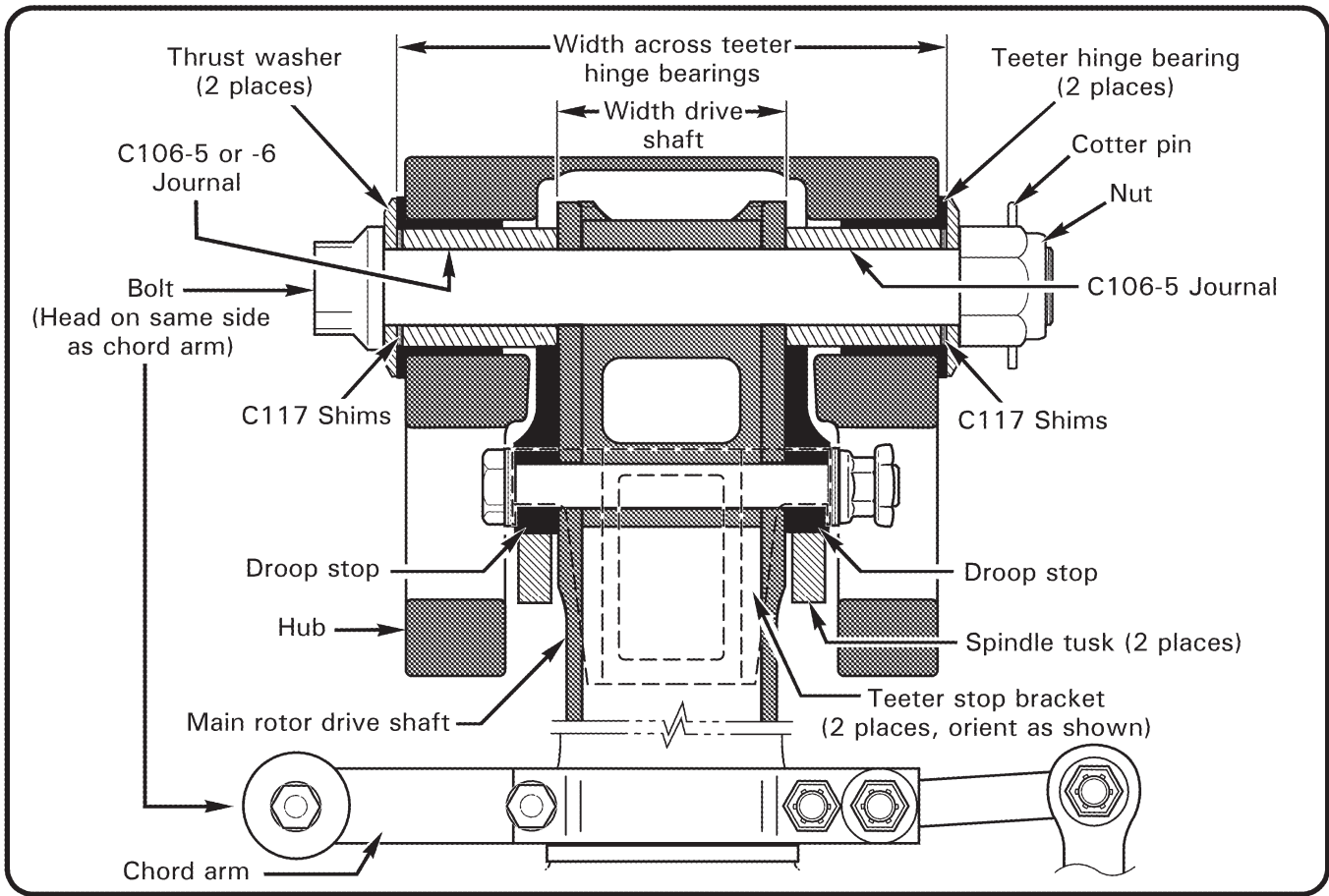

FIGURE 28-7 TEETER HINGE (HUB INSTALLATION)

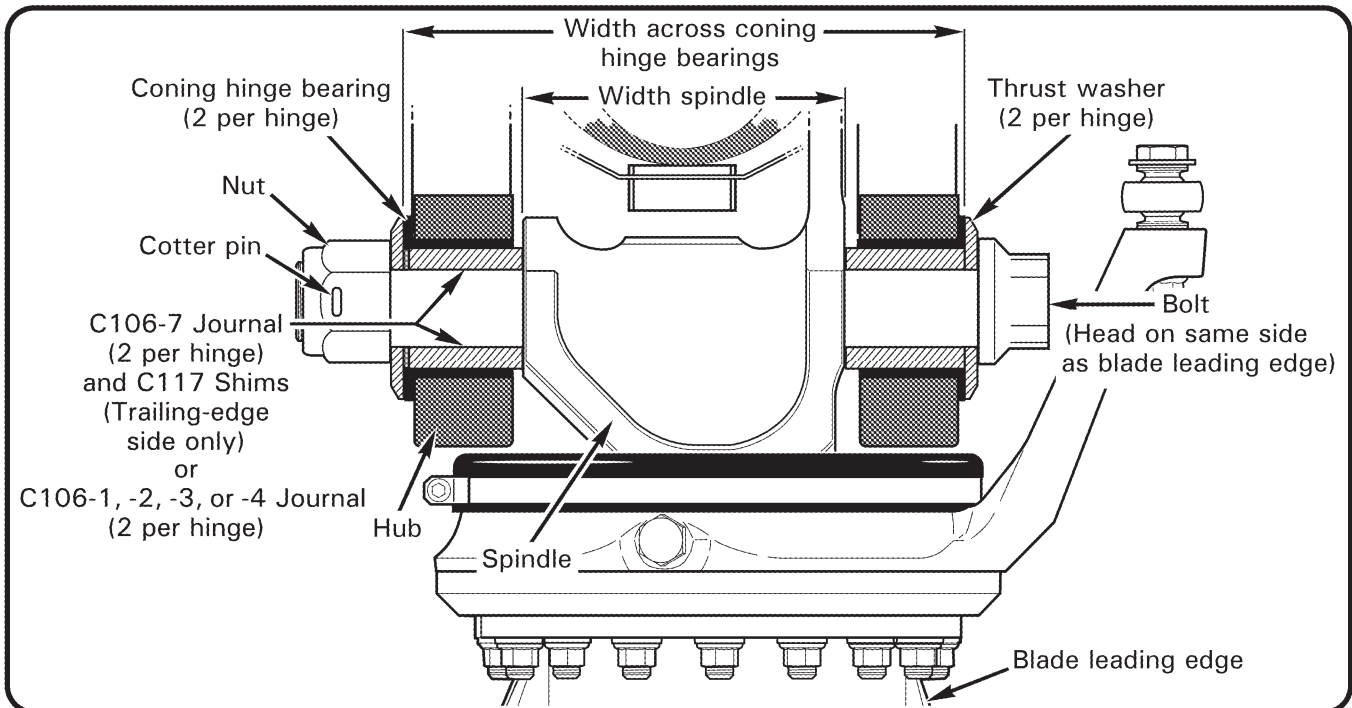

FIGURE 28-8 CONING HINGE (BLADE INSTALLATION; VIEW LOOKING DOWN)

C106 Journal Lengths		
<u>Part No.</u>	<u>Length</u>	<u>Location</u>
C106-1	1.300 in.	Coning hinge, no shims
C106-2	1.305 in.	Coning hinge, no shims
C106-3	1.310 in.	Coning hinge, no shims
C106-4	1.315 in.	Coning hinge, no shims
C106-5	1.775 in.	Teeter hinge (two, or one + C106-6 per hinge), shims
C106-6	1.815 in.	Teeter hinge (none, or one + C106-5 per hinge), shims
C106-7	1.284 in.	Coning hinge (two per hinge), shims

C117 Shim Sizes		
<u>Part No.</u>	<u>Thickness</u>	<u>Location (Between thrust washer and journal)</u>
C117-8	0.012 in.	Teeter hinge; Coning hinge trailing-edge side
C117-9	0.015 in.	Teeter hinge; Coning hinge trailing-edge side
C117-10	0.020 in.	Teeter hinge; Coning hinge trailing-edge side
C117-11	0.025 in.	Teeter hinge; Coning hinge trailing-edge side

TABLE 28-1 C106 JOURNAL LENGTHS AND C117 SHIM SIZES

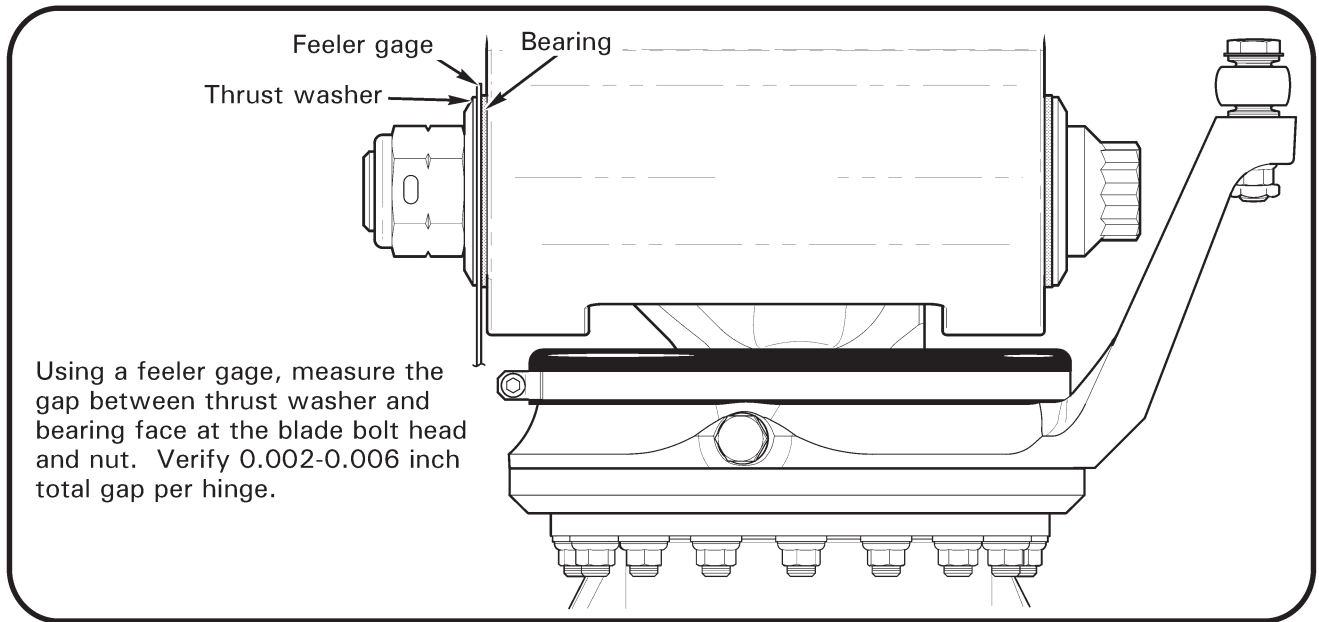

FIGURE 28-9 MEASURING CONING HINGE AXIAL GAP

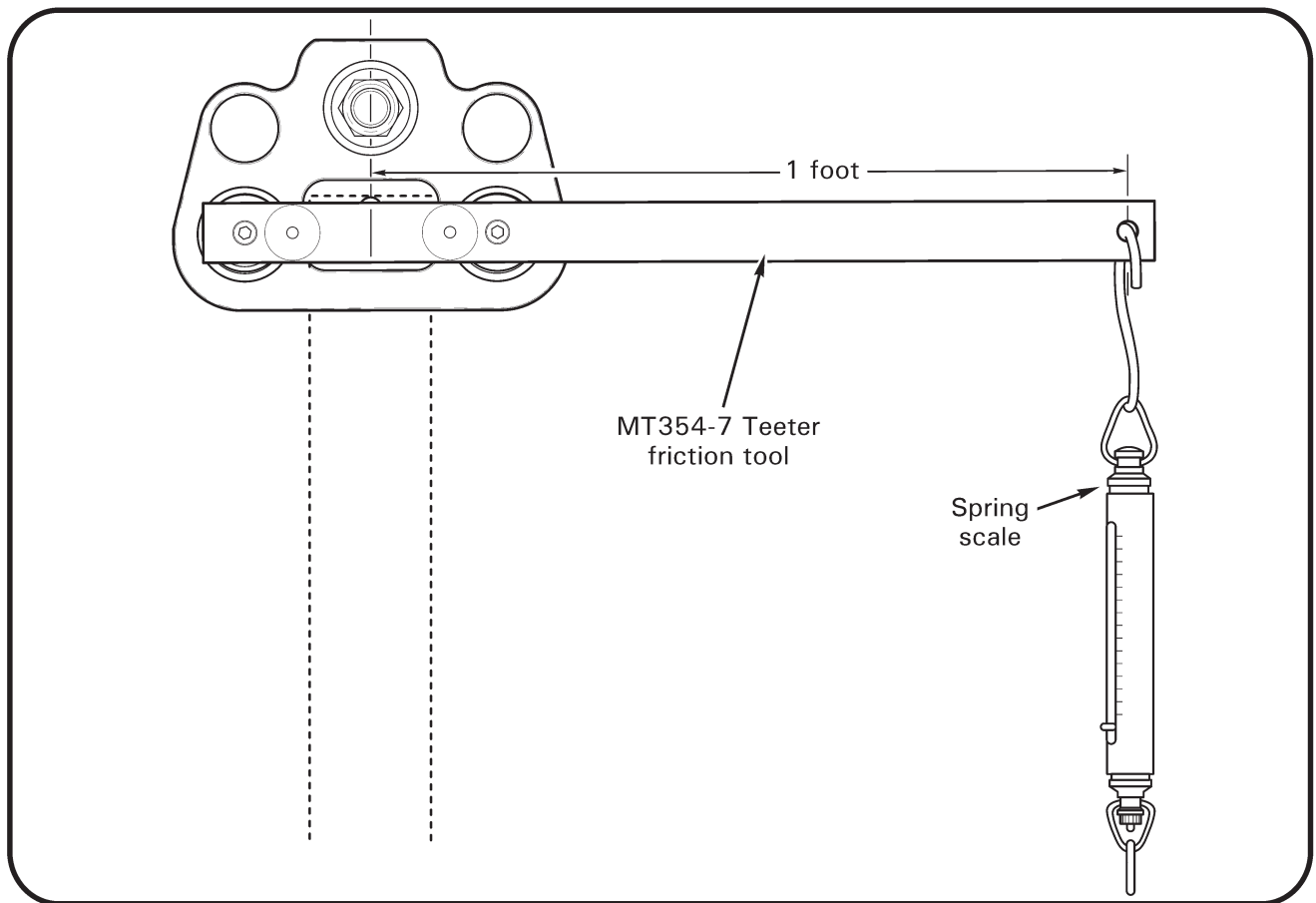

FIGURE 28-10 MEASURING TEETER HINGE FRICTION

28-32 Adjusting Hinge Friction

A. Teeter Hinge Friction Adjustment

1. Remove main rotor blades per § 28-10.
2. Refer to Figure 28-7 and Table 28-1. Remove cotter pin, nut, thrust washer, and nut-side C117 shims. Adjust teeter hinge friction by changing nut-side shim stack thickness in small increments; reducing shim stack thickness increases friction, increasing shim stack thickness reduces friction. Install shims, thrust washer, and nut.
3. Refer to Figure 28-10. While torquing teeter hinge bolt per § 23-33, check teeter hinge friction frequently. To check friction, install MT354 teeter friction tool into coning hinge bearings on one side of main rotor hub and measure moving force (not breakaway force) required to teeter main rotor hub with a spring scale.

NOTE

Do not exceed 20 ft-lb teeter friction. If bolt cannot be torqued per § 23-33 without exceeding friction limit, increase shim stack thickness per step 2.

4. Install a new bolt and nut per § 28-20.

B. Coning Hinge Friction Adjustment

1. Refer to Figure 28-8 and Table 28-1. Remove cotter pin, nut, thrust washer, and nut-side C117 shims (or journal). Adjust coning hinge friction by changing nut-side shim stack thickness (or journal length) in small increments; reducing shim stack thickness (or using a shorter journal) increases friction, increasing shim stack thickness (or using a longer journal) reduces friction. Coning hinge friction is zero when there is a measurable axial gap per Figure 28-7. Install shims (or journal), thrust washer, and nut.
2. Install a new bolt and nut per § 28-20, steps 7 thru 9. Repeat steps for opposite blade.
3. Check coning hinge friction by lifting blades until spindle tusks clear droop stops. Hold one blade level and cone opposite blade. Rotor hub may not teeter as blade is coned. Repeat check on opposite blade.
4. Using a feeler gage, measure gap between thrust washers and bearing faces at coning hinge bolt head and nut. Verify 0.002–0.006 inch total gap per hinge.
5. Drill nut and bolt per § 28-34. Install a new cotter pin wet with approved primer (chromate primer preferred; refer to § 23-75).

28-33 Shifting the Main Rotor Hub

1. Remove cotter pin, nut, thrust washer, and nut-side C117 shims.
2. Have two people cone the main rotor blades. Push out teeter hinge bolt with another bolt.
3. Move or exchange existing shims from one side of hub to the other as indicated by main rotor balance chart (refer to § 10.230).
4. Install teeter hinge bolt per § 28-20.

28-34 Drilling Main Rotor Hub Bolts**NOTE**

Protect hub from damage due to chuck contact by wrapping chuck and/or covering hub edge with several layers of tape.

New bolts and nuts must be installed and bolts stretched per § 23-33 prior to drilling.

Using a six-inch long 0.156-inch diameter Cobalt twist-drill and cutting oil, drill a hole through nut and bolt using an accessible pre-drilled hole in nut. The MT569-2 drill guide assembly will facilitate drilling a perpendicular hole. If a pre-drilled hole is inaccessible, completely loosen nut, slightly rotate bolt to favorable position, then special torque per § 23-33. Protect adjacent area from drilling debris.

Intentionally Blank

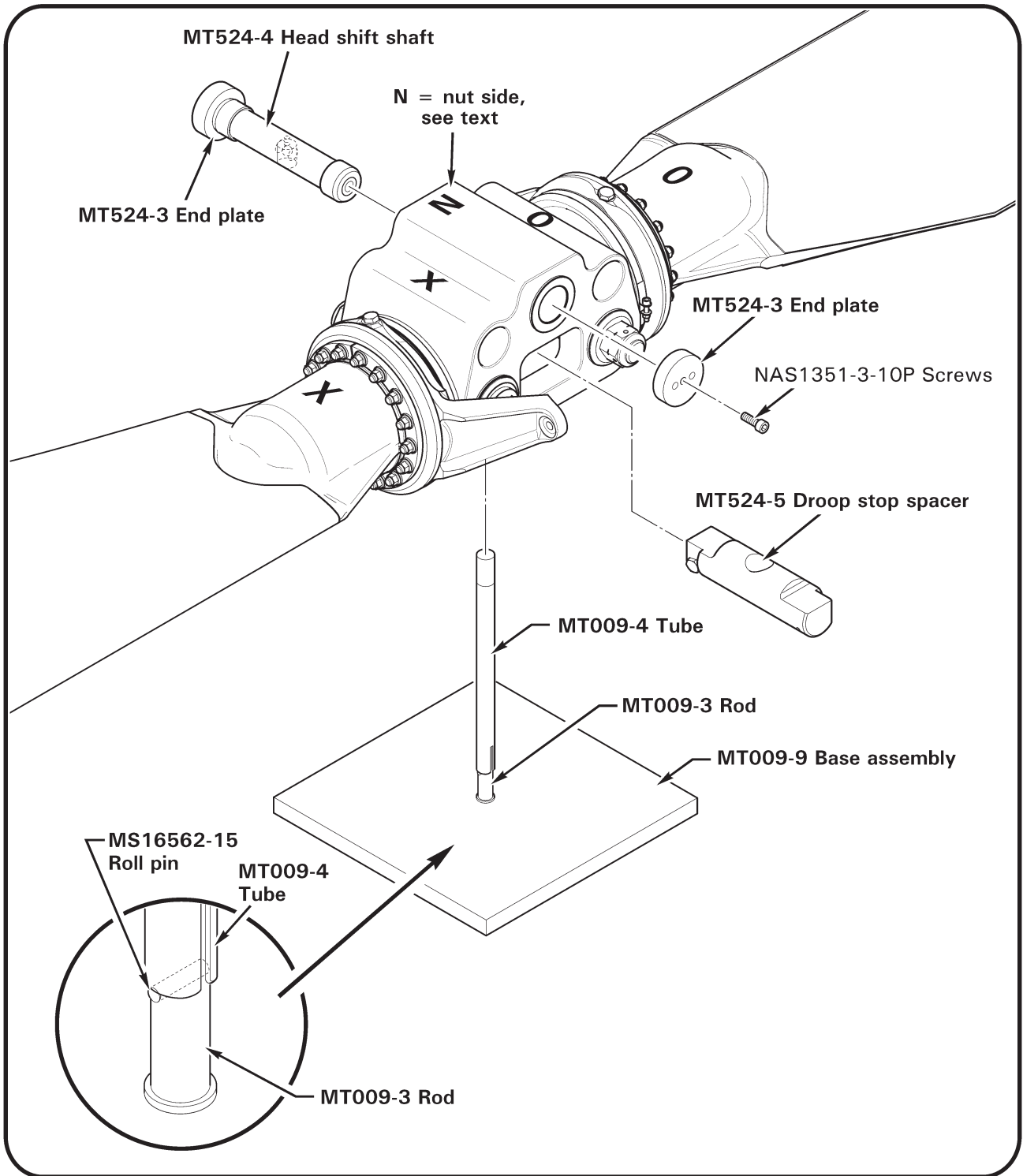

FIGURE 28-11A MT524-2 MAIN ROTOR STATIC BALANCE FIXTURE ASSEMBLY

28-35 Static Balance**CAUTION**

Ensure surfaces contacting blade skins and trailing edges are sufficiently cushioned to prevent blade damage.

1. Refer to Table 28-1. Assemble main rotor blade & spindle assembly to main rotor hub by selecting a combination of C106-7 coning hinge journals and C117 coning hinge shims to obtain total axial clearance between 0.002–0.006 inch.
2. Install nuts (dry); tighten nuts on hinge bolts until journals and thrust washers are firmly seated (snug). Measure gaps between thrust washers and hub bearing faces per Figure 28-8; verify total axial clearance at each hinge is between 0.002–0.006 inch.
3. Refer to Figure 28-11A. Install MT524-2 main rotor static balancing fixture assembly in hub as shown. Hoist main rotor assembly and position on MT009-9 base assembly.
4. Refer to Figure 28-11B. Verify blade pitch angles are approximately equal with pitch horns adjusted as shown. If blade pitch angles are not equal, then pitch horn(s) are not correctly installed.
5. Place a spirit level chordwise (parallel with teeter and coning hinges) atop main rotor hub. Level by adjusting NAS1351-3-10P screws.

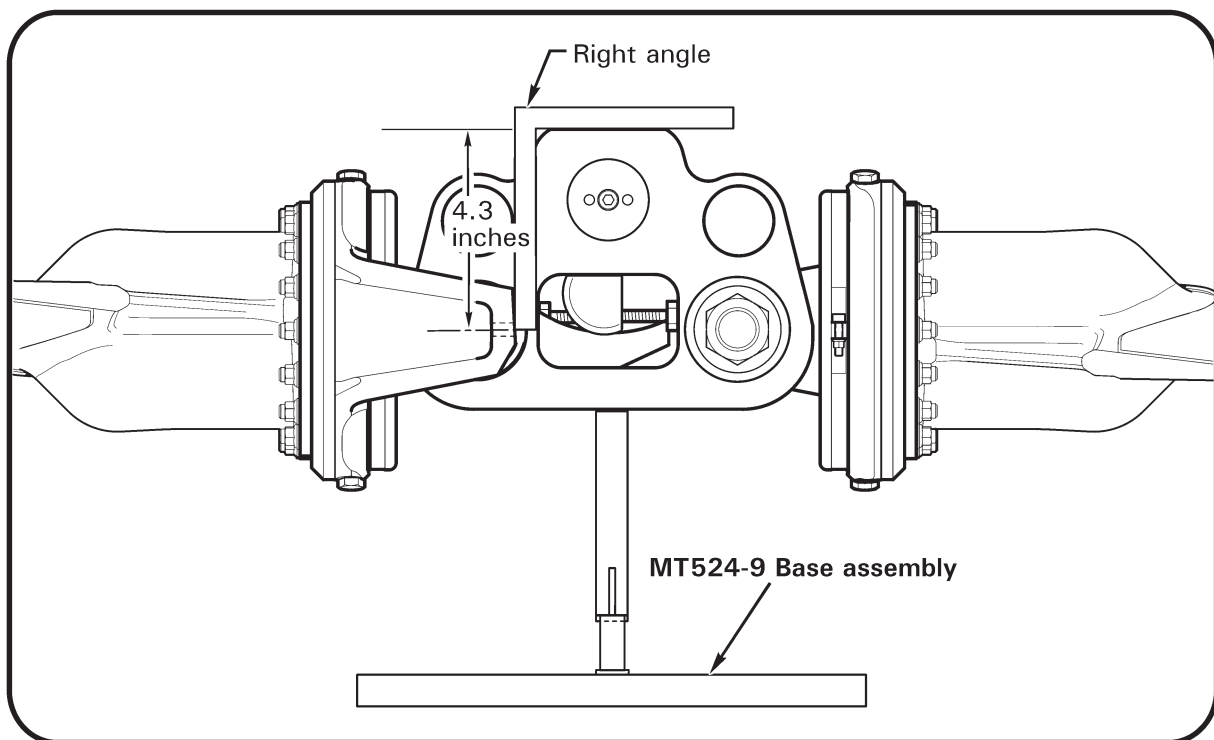

FIGURE 28-11B EQUALIZING BLADE PITCH

28-35 Static Balance (continued)

6. Refer to Figure 28-11C. Insert depth micrometer (or calipers) thru (either) hole of MT524-3 end plate until dowel contacts MT524-4 shaft and mark dowel at edge of end plate; repeat on opposite side of hub. Determine side of hub with smaller measured distance and mark top of hub with letter "N" to indicate nut-side of teeter hinge bolt.
7. Place a spirit level spanwise (perpendicular to teeter and coning hinges) atop main rotor hub. Place tip cover, tip cover attach screws, and two A722-4 screws as close to blade tip as possible. Level rotor system by adding C298 balance strips, NAS1149F0332P washers, and/or NAS1149F0363P washers as required. Final balance to be within one NAS1149F0332P washer.
8. Apply light coat A257-9 anti-seize to threads and install screws securing tip weights to blade; special torque screws to 40 in.-lb. Apply light coat A257-9 anti-seize to threads and install screws securing tip cover to blade; special torque screws to 40 in.-lb. Recheck spanwise and chordwise balance.
9. Conspicuously mark rotor assembly with colored "X" and "O" on hub, blade roots, and coning bolts (consistent marking on each side of hub) as reference for correct assembly on helicopter. Disassemble main rotor assembly.

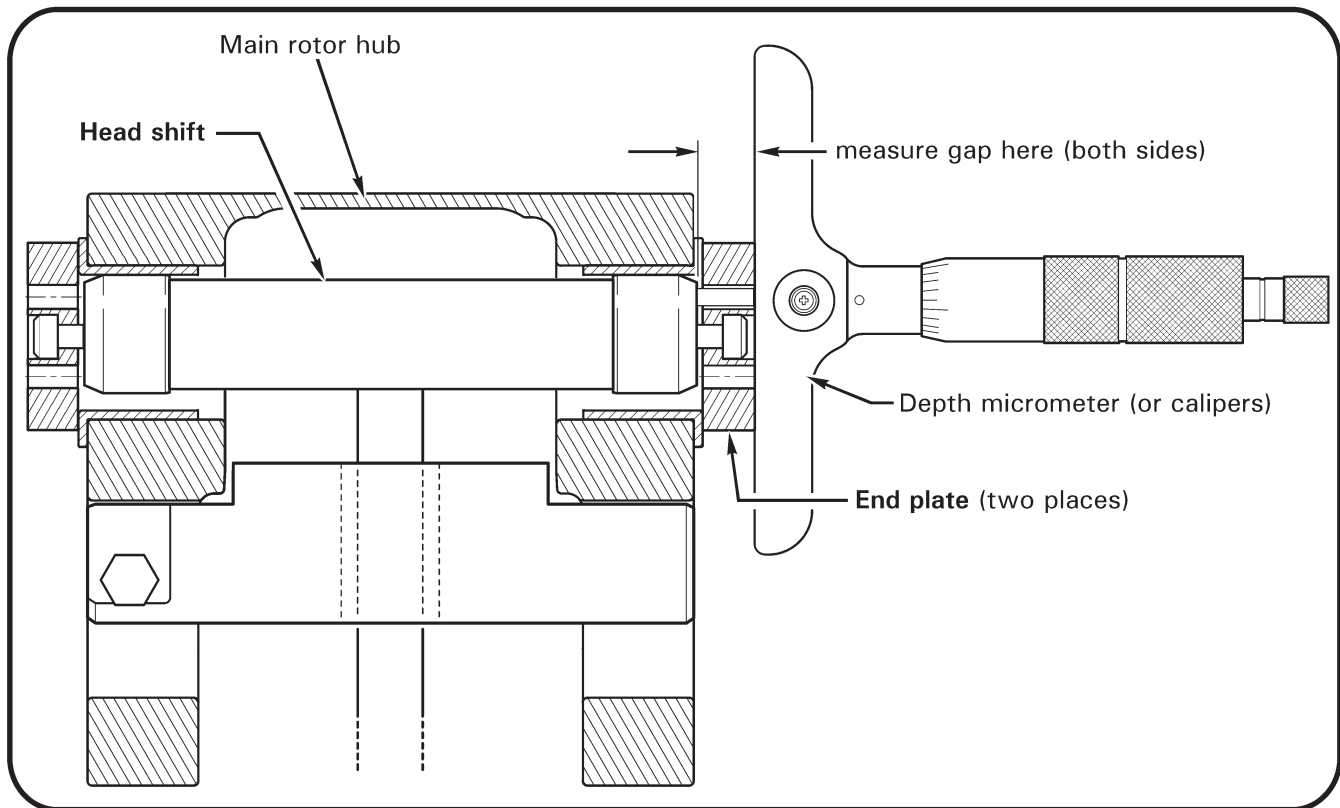

FIGURE 28-11C MEASURING GAP BETWEEN THRUST WASHER AND HUB BEARING

Intentionally Blank

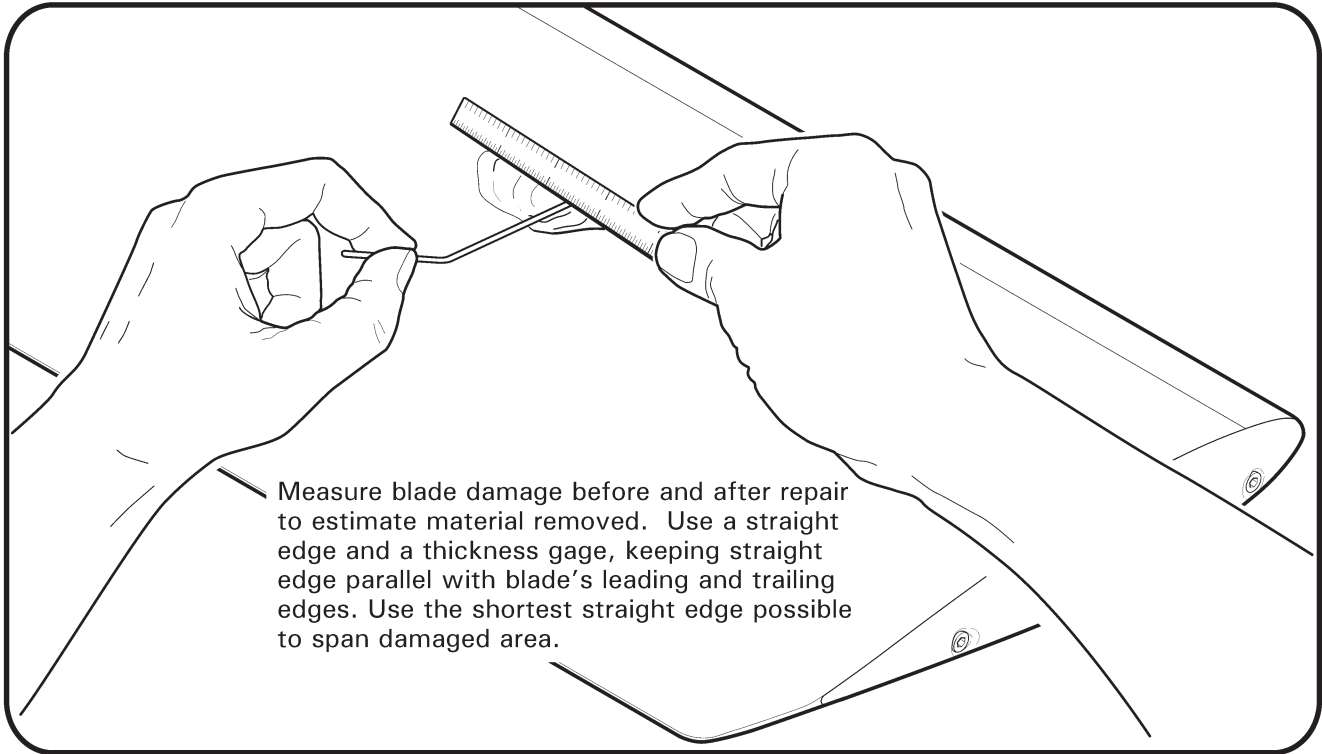

FIGURE 28-12 MEASURING MAIN ROTOR BLADE DAMAGE

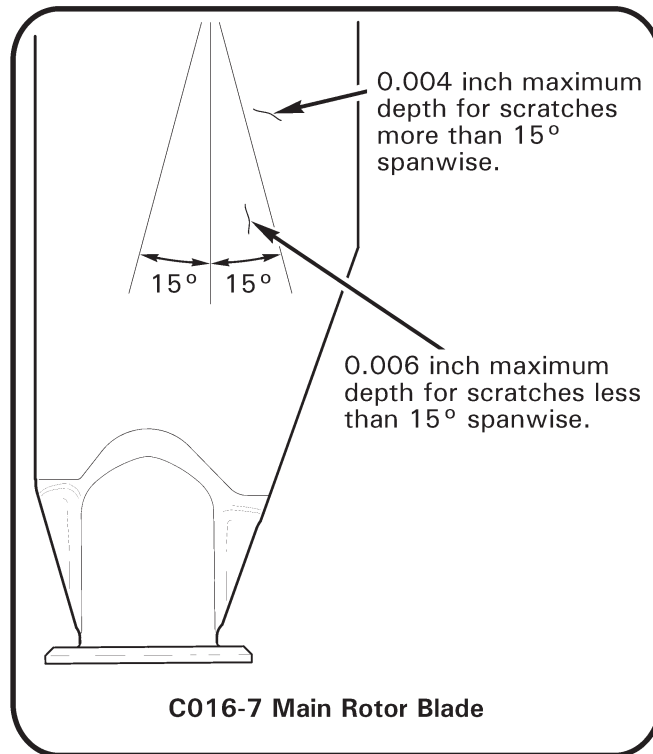

FIGURE 28-13 SCRATCH LIMITS

28-40 Inspection of Main Rotor Blades**NOTE**

Main rotor blades are 14 CFR § 27.602 critical parts. Notify RHC Technical Support when voids exceeding the limits specified in the instructions below are found, providing blade serial number, helicopter serial number, time in service for the rotor blade, and location and size of the voids that exceed the limits.

NOTE

The inspection criteria in this section applies to blade damage that occurs after blade manufacturing (including shipping and handling and time in service). Damage after blade manufacturing usually exhibits paint scuffing, scratches, or freshly-exposed metal in the form of scratches in the finish. If a blade manufacturing irregularity is suspected, contact [RHC Technical Support](#).

CAUTION

A blade may be repaired more than one time. However, in no case can more than the maximum material be removed or the maximum dent depth be exceeded in any one location.

CAUTION

Any blade that encounters inspection-penetrant (dye or fluorescent) of a blade bond joint is scrap.

A. Measuring Damage

1. Refer to Figure 28-12. Measure blade damage using a straight edge and a thickness gage. Keep straight edge parallel with the leading and trailing edges.
2. If blades are installed on the helicopter, measure damage using the shortest straight edge possible to span damaged area. Using a straight edge of excessive length will cause a false reading due to natural droop of the blade.

B. Measuring Material Removed After Repair

1. Use calipers or micrometers and compare measurements before and after repair to estimate amount of material removed.
2. Use a straight edge and thickness gage to measure repaired areas less than 2 inches across in the blade skins and spar.

28-41 Scratches and Corrosion on Blade Skins and Doublers

1. Refer to Figure 28-13. Damage may not exceed the following limits after rework:

C016-7 Blades:

- a. 0.004 inch maximum depth for scratches more than 15° from spanwise axis.
 - b. 0.006 inch maximum depth for scratches less than 15° from spanwise axis.
 - c. 0.012 inch maximum corrosion between RS 174.0 and RS 198.0.
 - d. 0.008 inch maximum corrosion between RS 124.0 and RS 174.0.
 - e. 0.006 inch maximum corrosion between RS 58.0 and RS 124.0.
 - f. 0.010 inch maximum corrosion between RS 18.7 and RS 58.0.
2. Refer to § 28-50 for repair procedures for damage within limits. Polish out damage by hand with 0.10 inch blend radius.

Intentionally Blank

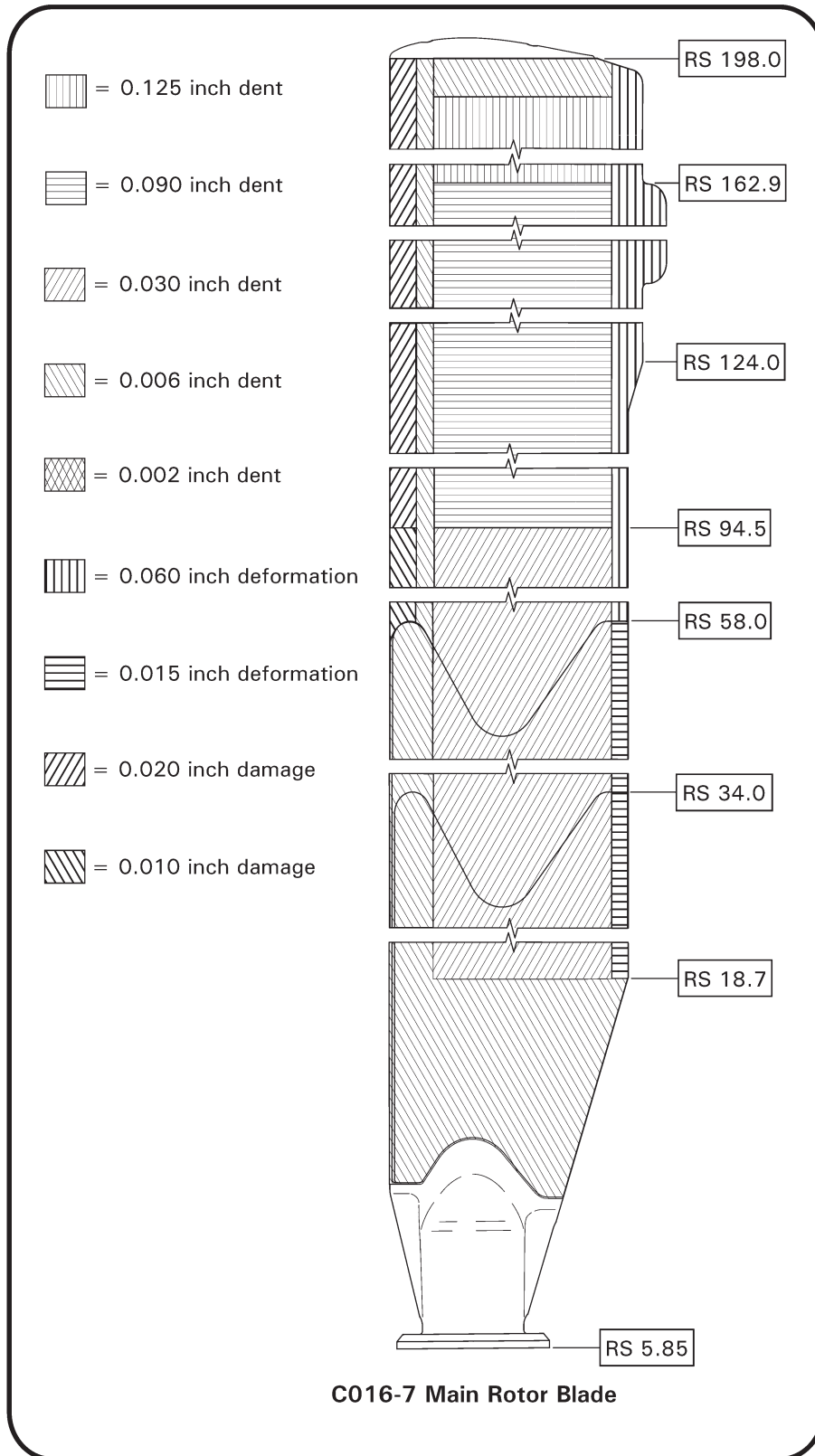

FIGURE 28-14 DENTS AND LOCAL DEFORMATIONS

28-42 Dents and Local Deformations**CAUTION**

Tap-test dented areas in honeycomb using an AN970-4 washer or 1965-or-later U.S. quarter dollar coin in good condition. If any voids are found associated with dents, contact [RHC Technical Support](#).

CAUTION

Do not repair any dent that has a sharp cut or break in the skin; dent must have 0.060 inch minimum radius. If necessary, locally penetrant inspect, keeping penetrant materials away from bond joints.

1. Refer to Figure 28-14. Damage may not exceed the following limits:
 - a. Honeycomb:
 - i. 0.020 inch maximum bulge on opposite side of blade, opposite dent.
 - ii. 0.125 inch maximum depth dent between RS 162.90 and RS 198.0.
 - iii. 0.090 inch maximum depth dent between RS 94.5 and RS 162.9.
 - iv. 0.030 inch maximum depth dent between RS 18.7 and RS 94.5.
 - b. Leading edge of doublers: 0.010 inch maximum depth dent.
 - c. Supported bond joints:

C016-7 Blades: 0.006 inch maximum depth dent.
 - d. Local deformations:

C016-7 Blades: Within 0.75 inch forward of trailing edge:
 - i. 0.060 inch deformation between RS 58.0 and RS 198.0.
 - ii. 0.015 inch deformation between RS 18.7 and RS 58.0.
 - e. Spar: Refer to step 2. Blend damaged areas by hand with a minimum 1.0 inch blend radius. Blending is not allowed within 0.010 inch of spar groove leading edge.

C016-7 Blades:
 - i. 0.020 inch maximum depth damage between RS 94.5 and RS 198.0.
 - ii. 0.010 inch maximum depth damage between RS 58.0 and RS 94.5.
2. Refer to § 28-50 for repair procedures for damage within limits. Smooth, round bottom dents with 0.060 inch minimum radius may be filled and faired to an aerodynamic shape.

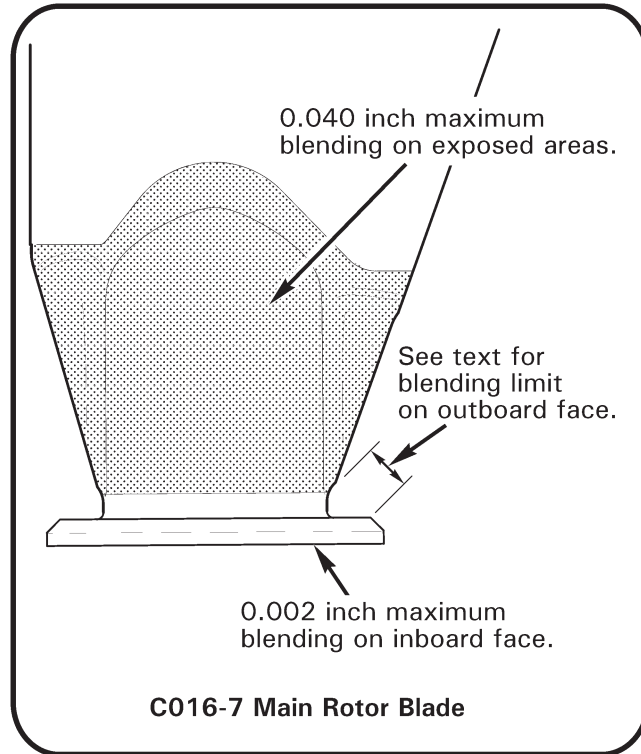

FIGURE 28-15 ROOT FITTING BLEND LIMITS

28-43 Root Fitting Damage

1. Refer to Figure 28-15. Damage may not exceed the following limits:

C016-7 Blades:

Refer to step 2. Blend damaged areas by hand with a minimum 0.030 inch blend radius.

- a. 0.002 inch maximum depth blending on flange inboard face.
- b. 0.005 inch maximum depth, 0.250 inch maximum diameter blending on flange outboard machined face (3 blends maximum). 0.10 inch minimum distance from hole edges.
- c. 0.040 inch maximum depth blending on exposed areas of root fitting.

2. Refer to § 28-50 for repair procedures for damage within limits.

Intentionally Blank

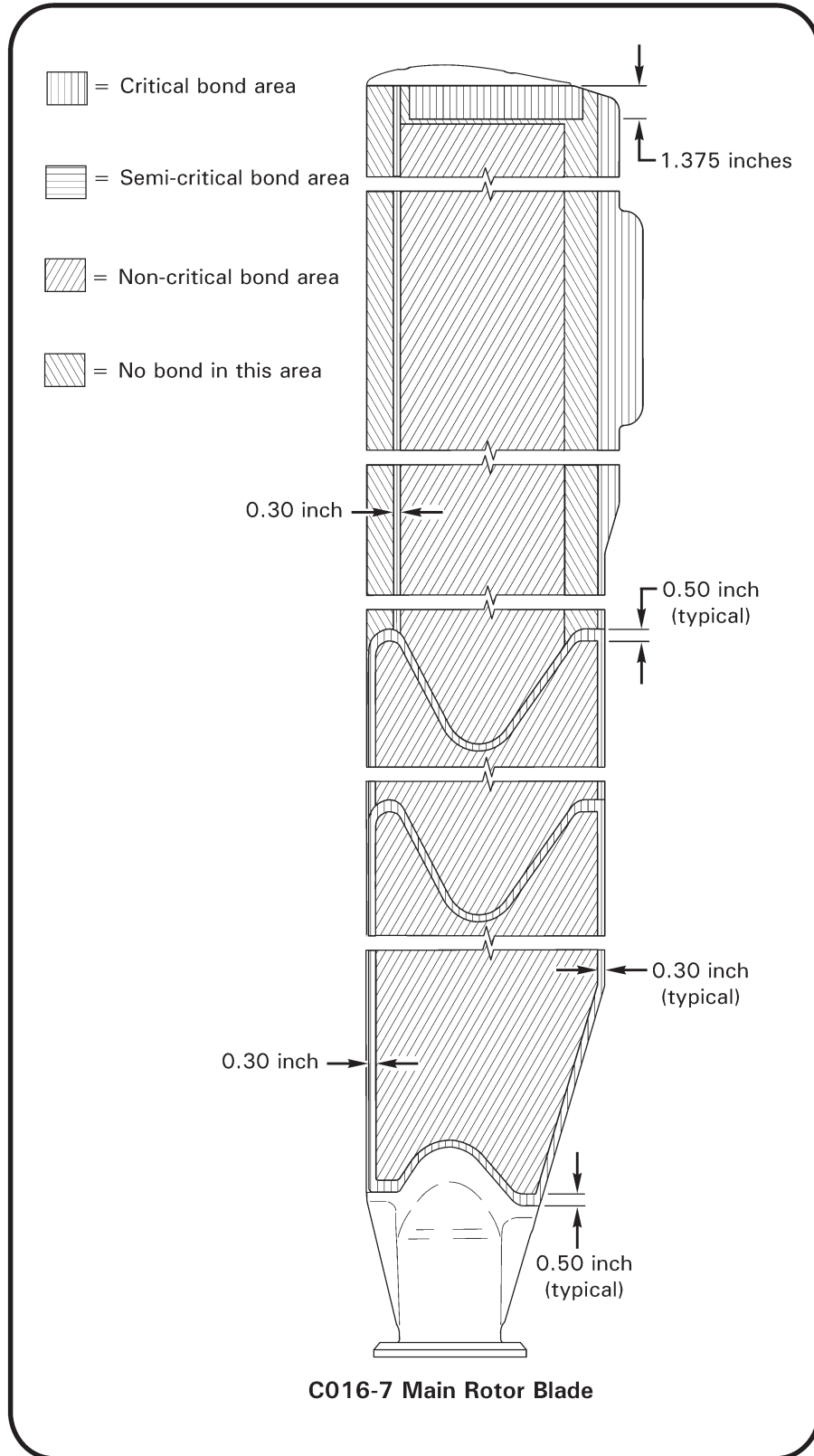

FIGURE 28-16 BOND AREAS

28-44 Voids**CAUTION**

Tap-test voids and debonds in blades using an AN970-4 washer or 1965 or later U.S. quarter dollar coin in good condition.

CAUTION

Voids or debonds in doublers are not field repairable. If voids or debonds are detected in doublers which exceed limits, contact [RHC Technical Support](#).

A. Critical Bond Areas

Refer to Figure 28-16. Critical bond areas are areas less than 0.50 inch spanwise and less than 0.30 inch chordwise from the edge of any structural bond joint.

Bond areas not defined as semi-critical or non-critical are considered critical.

Voids separated by less than 0.25 inch are considered continuous.

1. Damage may not exceed the following limits:
 - a. 0.10 square inch maximum void.
 - b. Area must be at least 90% bonded.

B. Semi-Critical Bond Areas**C016-7 Blades:**

C016-7 Blades do not have semi-critical bond areas.

C. Non-Critical Bond Areas

Refer to Figure 28-16. Non-critical bond areas are areas more than 0.50 inch spanwise or more than 0.30 inch chordwise from doubler edges and bonded areas between skin and honeycomb.

28-44 Voids (continued)**C. Non-Critical Bond Areas (continued)****C016-7 Blades:**

1. Voids in doubler bond joints separated by less than 0.25 inch are considered continuous. Damage in doubler bond joints may not exceed the following limits:
 - a. Area must be at least 80% bonded.
 - b. 6.0 square inches, 2.0 inches chordwise, & 7.0 inches spanwise maximum void.
 - c. 0.10 square inch maximum of a void extending into a critical bond area.
 - d. Voids are permissible within 0.30 inch of doubler leading edge where it wraps around spar and root fitting.

2. Voids in honeycomb bond joints separated by less than 0.50 inch spanwise or 1.0 inch chordwise are considered continuous. Damage in honeycomb bond joints may not exceed the following limits:
 - a. Area must be at least 80% bonded.
 - b. 15.0 square inches, 1.5 inches chordwise, & 20.0 inches spanwise maximum void inboard of RS 121.0.
 - c. 15.0 square inches, 2.5 inches chordwise, & 20.0 inches spanwise maximum void outboard of RS 121.0.

28-50 Repair of Main Rotor Blades**WARNING**

Unauthorized repairs to rotor blades have caused fatal crashes.

CAUTION

Do NOT use power tools, chemical paint strippers, or chemical corrosion removers to repair main rotor blades.

NOTE

Refer to § 23-70 for approved materials.

1. Measure damage per § 28-40.
2. Remove damage at trailing edges, trim tab edges, tip cap, and/or tip corner by trimming per § 28-51 as required.
3. Polish out damage using 220 grit or finer wet-or-dry aluminum-oxide or silicon-carbide abrasive paper, and finish with 320 grit or finer wet-or-dry abrasive paper. A fine-toothed file may be used along the spar and trailing edge, provided the area is finished with 320 grit or finer wet-or-dry abrasive paper. Sand or file in spanwise direction. Remove only the material necessary to remove the damage and blend to the radius or dimension specified. Visually inspect and verify damage is removed.
4. Measure material removed per § 28-40. Verify repair does not exceed limit specified.
5. Seal or fill as required per the following:
 - a. Clean area to be sealed or filled using approved solvent (refer to § 23-70).
 - b. Apply approved primer (chromate primer preferred; refer to § 23-75) to bond joints with pin holes or other openings. Mix primer per manufacturer's instructions. Allow a minimum of 24 hours cure time.
 - c. Using 220-grit or finer wet-or-dry aluminum-oxide or silicon-carbide abrasive paper, hand-sand cured adhesive in spanwise direction to a smooth, aerodynamic finish, congruent with the blade airfoil. Do not remove metal.
 - d. Hand-sand surrounding painted surface until 25% primer remains. Keep bare metal to a minimum.
6. Paint per § 28-52 as required.
7. Track and balance main rotor per § 10.230 as required.

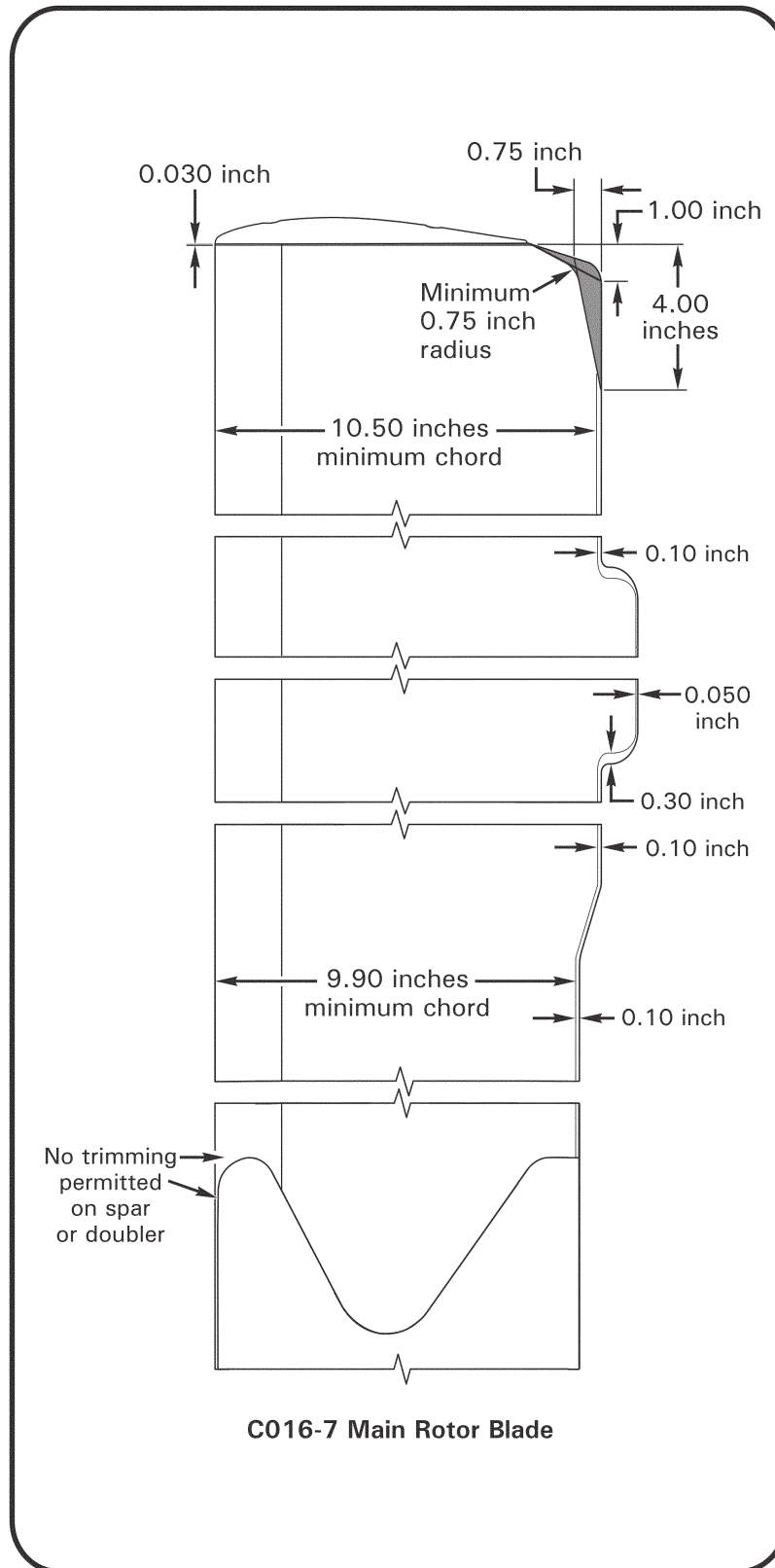

FIGURE 28-17 TRIM LIMITS

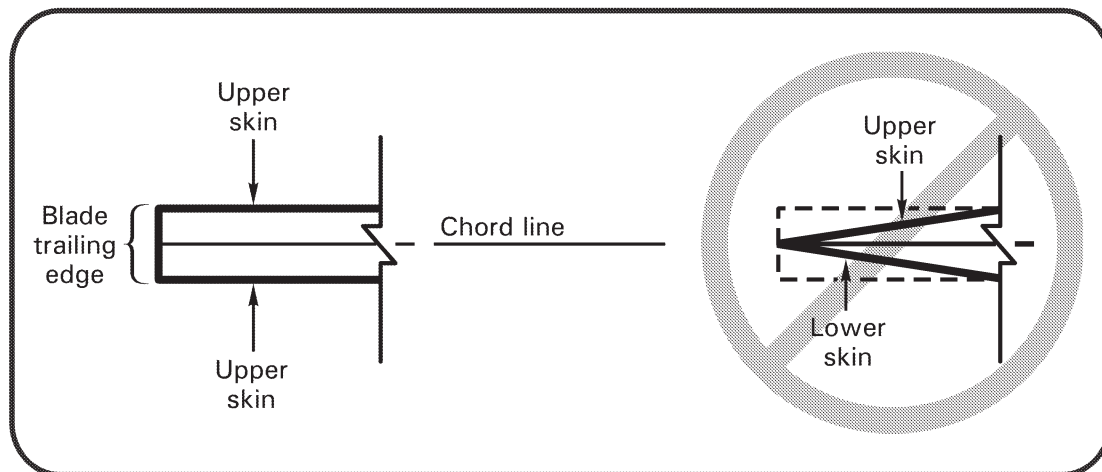

FIGURE 28-18 FILING EDGES SQUARE WITH SKINS

28-51 Trimming

Refer to Figures 28-17 & 28-18. Trimming may be performed on the trailing edge of main rotor blade skins and trim tab edges within limits shown. (Alternately, a trailing edge nick or notch may be blended out 1.0 inch minimum spanwise, each side of nick or notch within limits shown.) Trimming is not permitted on spar or doublers.

Tip cap and tip corner may be trimmed within limits shown.

Finish repair per § 28-50 steps 2 thru 7. File trailing edge or trim tab edges square with skins (do not file into a point). Verify minimum chord dimension.

28-52 Painting

Refer to § 23-70 for approved materials. Refer to paint manufacturer's recommendations.

CAUTION

If force-drying paint, do not exceed 175° F surface temperature on blade; monitor blade temperature.

1. Remove main rotor blade tip cover(s) as required. Clean the blade(s).
2. Feather edge of paint bordering bare metal by hand-sanding spanwise with 220-grit or finer wet-or-dry aluminum-oxide or silicon-carbide abrasive paper. Do not remove metal.
3. Mask area to prevent overspray contamination.
4. Clean bare metal to be painted with a lint-free cloth dampened with enamel cleaner.
5. Prime bare metal, including bare metal under tip cover(s) as required, with at least two coats approved primer (chromate primer preferred; refer to § 23-75). Scuff first coat of primer with 320-grit abrasive paper (or very fine Scotch-Brite), and wipe down with a lint-free cloth dampened with enamel cleaner prior to applying second coat.

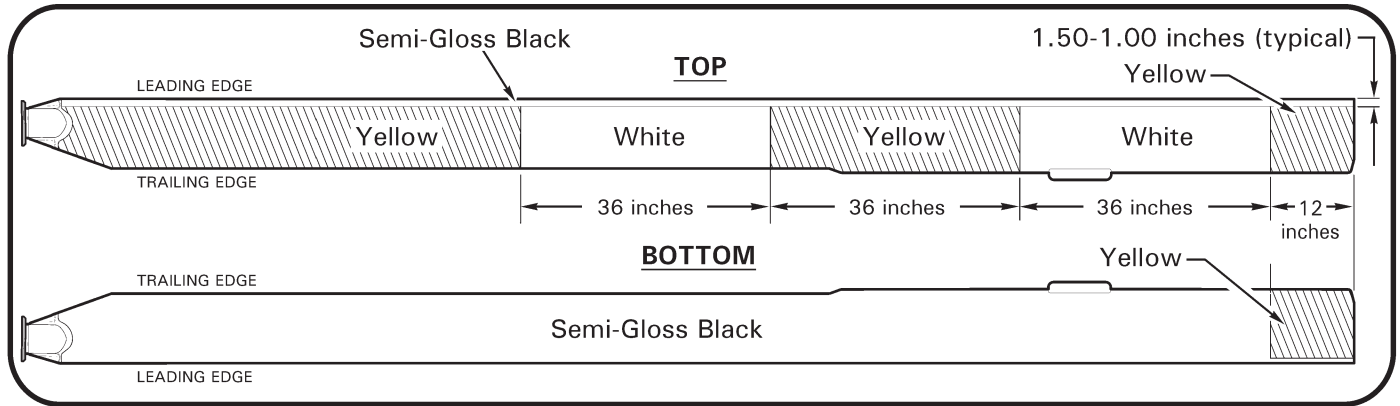

FIGURE 28-19 C016-7 MAIN ROTOR BLADE PAINT SCHEME

28-52 Painting (continued)

6. Refer to Figure 28-19. Apply dark gray, flat black, white, and/or yellow polyurethane enamel, as required, to primed area in accordance with paint manufacturer’s recommendations.

NOTE

Allow Imron paint to cure at least 72 hours before flying in erosive conditions (such as drizzle, rain, or dust).

7. Install blade tip cover(s) if removed.
8. Remove masking materials.

28-60 Main Rotor Blade Tip Maintenance

After removing rounded tip covers, use 10X magnification when visually inspecting blade tip to verify no loose or blistered paint, white-powder corrosion products, or pitting of skins aft of skin-to-spar bond lines (upper & lower). If bare metal (other than spar leading edge) or corrosion is detected, proceed as follows:

WARNING

Review appropriate Safety Data Sheet (SDS) when working in proximity to hazardous materials. Specific recommendations for use of personal protective equipment are located in the SDS.

CAUTION

Do NOT use power tools or chemical paint strippers to remove blade paint.

1. Remove any corrosion and loose paint on tip cap and outboard edges of blade skins by hand-sanding vertical surface in a chordwise direction; use a hard, flat block with 220-grit aluminum-oxide abrasive paper, then finish sand with 320-grit aluminum-oxide abrasive paper. Remove only material necessary to eliminate corrosion.

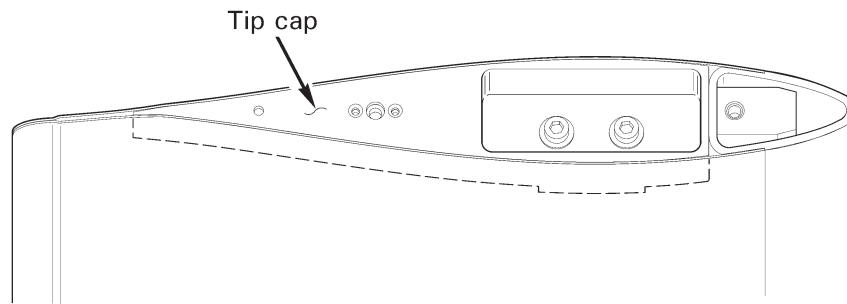

2. Remove any corrosion and loose paint from skins on upper or lower surface of blade, aft of skin-to-spar bond joint, by hand-sanding in a spanwise direction using 220-grit aluminum-oxide abrasive paper and minimum 0.1 inch blend radius; finish sand with 320-grit aluminum-oxide abrasive paper. Remove only material necessary to eliminate corrosion.

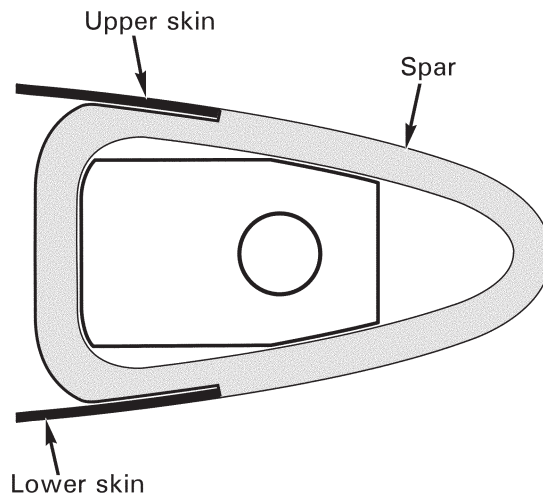

28-60 Main Rotor Blade Tip Maintenance (continued)

3. Clean bare metal area with lint-free cloth dampened with acetone and allow to dry.
4. Seal exposed bond joints, including bond joints on vertical surfaces, with smooth layer of B270-1 sealant (poly-sulfide, refer to § 23-79) and allow to cure.
5. Prime remaining exposed metal with two coats of epoxy primer (chromated epoxy preferred).
6. Apply yellow paint topcoat within 2–48 hours of primer application. For best performance, allow paint to cure 48 hours before flight.
7. Install tip covers and special torque screws to 40 in.-lb wet with A257-9 anti-seize; ensure cover edges are flush with blade profile.

CHAPTER 29

MAIN ROTOR DRIVE SYSTEM

<u>Section</u>	<u>Title</u>	<u>Page</u>
29-00	Description	29.1

Intentionally Blank

CHAPTER 29**MAIN ROTOR DRIVE SYSTEM**29-00 Description

Reserved.

Intentionally Blank

CHAPTER 30**TAIL ROTOR**

<u>Section</u>	<u>Title</u>	<u>Page</u>
30-00	Description	30.1
30-10	Tail Rotor Assembly	30.1
30-11	Static Balance	30.7
30-20	Tail Rotor Blades	30.10
30-30	Tail Rotor Blade Inspection and Repair	30.13
30-31	Scratches and Corrosion	30.13
30-32	Dents	30.14
30-33	Erosion	30.15
30-34	Root Fitting Damage	30.15
30-35	Nicks and Notches	30.15
30-36	Painting	30.17
30-40	Tail Rotor Hub	30.19
30-41	Elastomeric Bearing Replacement	30.19
30-42	Spherical Bearing Replacement	30.21
30-43	Inspection	30.24

Intentionally Blank

CHAPTER 30

TAIL ROTOR

30-00 Description

The tail rotor has two all-metal blades and a teetering hub with a fixed coning angle. The pitch change bearings have self-lubricated liners. The teeter hinge bearings either have self-lubricated liners or are elastomeric. The tail rotor blades are constructed with aluminum skins and root fittings. Maintaining the paint finish will reduce corrosion and erosion.

30-10 Tail Rotor Assembly**A. Removal**

1. Refer to Figure 30-1 or Figure 30-2. Mark or tag each pitch link and corresponding blade for reinstallation. Remove hardware securing pitch links to tail rotor blades, noting hardware removed.

NOTE

Tail rotor pitch link-to-blade attach bolts may be different lengths and/or have different washers installed under nut for balancing.

2. Remove nut and A141-14 washer securing C119-2 bumper to tail rotor gearbox output shaft.
3. Remove teeter hinge bolt, then slide tail rotor assembly and bumper, and C130-1 spacers (C030 hubs only), off of shaft.

NOTE

Protect tail rotor assembly from damage when maintenance is performed on workbench.

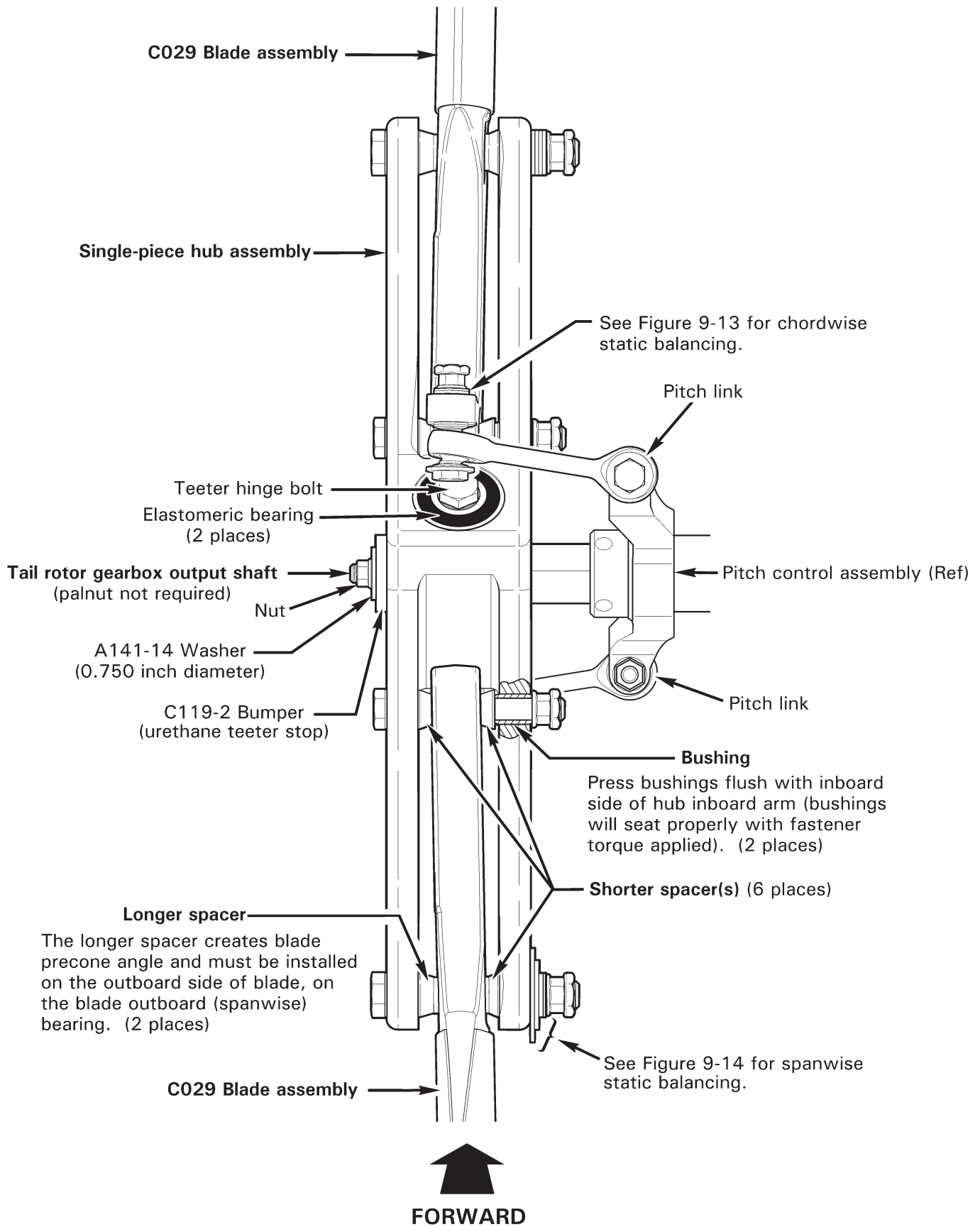

FIGURE 30-1 SINGLE-PIECE HUB TAIL ROTOR ASSEMBLY INSTALLATION

30-10 Tail Rotor Assembly (continued)**B. Installation of Single-Piece Hub (Elastomeric Bearing) Tail Rotor Assembly**

1. Refer to Figure 30-1. Position tail rotor assembly on tail rotor gearbox output shaft, matching tail rotor blades to corresponding pitch links. Verify tail rotor is installed for clockwise rotation when viewed from left side of aircraft.
2. Install teeter hinge bolt and tighten nut until elastomeric bearing metal spacers contact output shaft, but do not torque. Verify blades cone toward tail rotor gearbox.

CAUTION

If balancing hardware information is unknown, perform static balance per § 30-11.

3. Remove tags. Install hardware securing tail rotor blades to pitch links as removed, or as determined by static balancing. Standard torque nuts & palnuts per § 23-32, and torque stripe per Figure 2-1.
4. Fabricate a tracking aid using 1x12-inch aluminum sheet; make a 90° bend 2 inches from one end. With tail rotor horizontal, tape tracking aid to tailcone near blade tip.
5. Rotate tail rotor drive shaft and mark tracking aid where each blade tip drain hole passes. Adjust (teeter) tail rotor until both blade tips pass the same point within 0.125 inch. Special torque teeter hinge bolt per § 23-33. Recheck track. Repeat step until blades are tracked.
6. Install palnut on teeter hinge bolt, standard torque per § 23-32, and torque stripe per Figure 2-1. Remove tracking aid.
7. Teeter tail rotor hub back and forth. Verify teeter hinge bolt, bearing metal spacers, washers, and nuts remain stationary when tail rotor is teetered.
8. Install C119-2 bumper, A141-14 washer, and nut. Standard torque nut per § 23-32 and torque stripe per Figure 2-1.
9. Dynamically balance tail rotor per § 10.240.

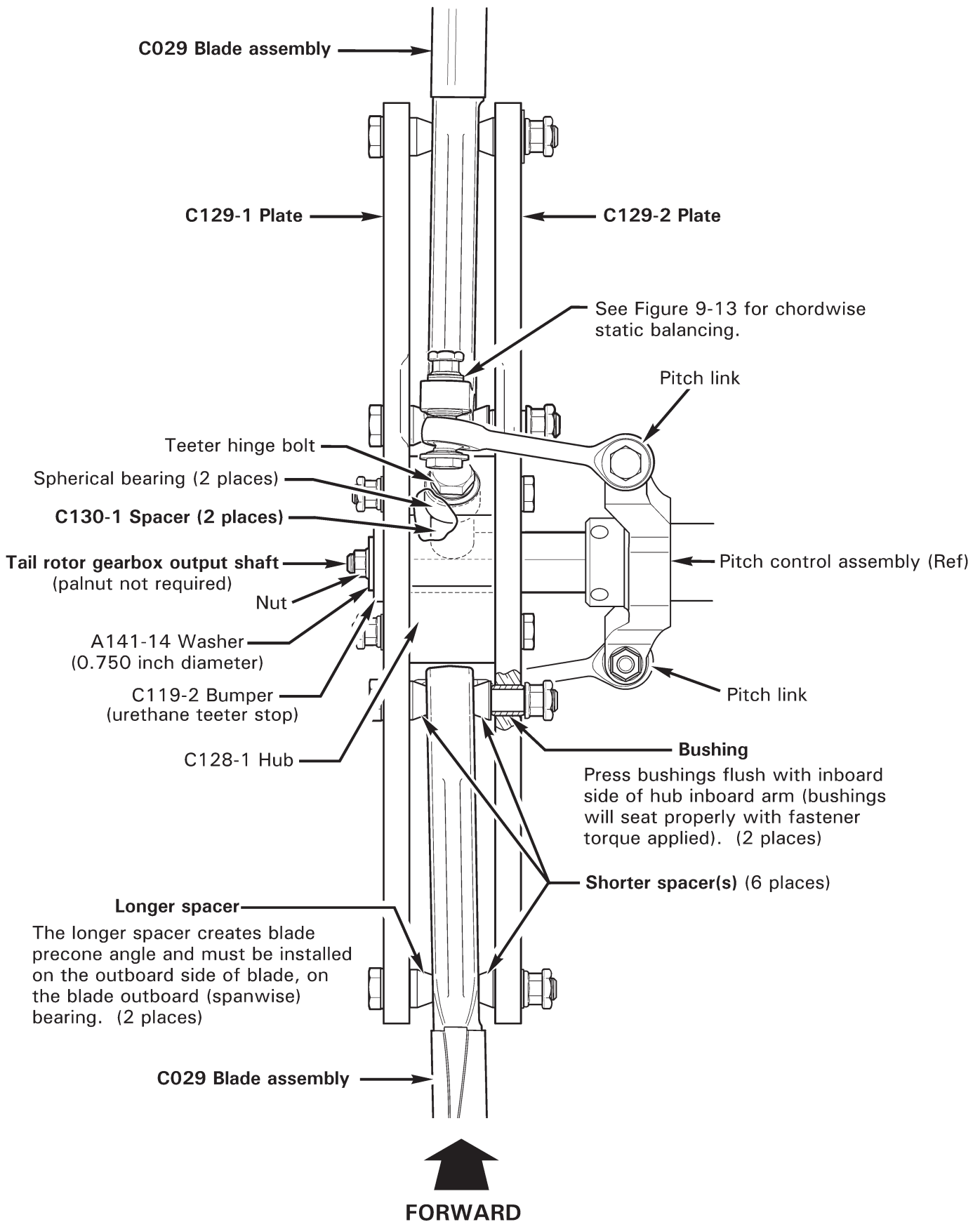

FIGURE 30-2 THREE-PIECE HUB TAIL ROTOR ASSEMBLY INSTALLATION

30-10 Tail Rotor Assembly (continued)**C. Installation of Three-Piece Hub (Spherical Bearing) Tail Rotor Assembly**

1. a. Verify C130-1 spacer faces are not worn.
 - b. Verify tail rotor gearbox output shaft flats are not worn. Verify output shaft teeter hinge bolt hole is not elongated.
2. Refer to Figure 30-2. Position C130-1 spacers inside hub and install tail rotor assembly on tail rotor gearbox output shaft, matching tail rotor blades to corresponding pitch links. Verify tail rotor is installed for clockwise rotation when viewed from left side of aircraft.
3. Install teeter hinge bolt, standard torque nut & palnut per § 23-32, and torque stripe per Figure 2-1. Verify blades cone toward tail rotor gearbox.

WARNING

Failure to check tail rotor bearing for proper installation per the following step can result in failure of teeter hinge bolt and loss of tail rotor.

4. a. Mark a line on exposed portion of each bearing ball using a felt pen or grease pencil.
 - b. While teetering tail rotor, observe marked line in relation to output shaft. Verify bolt, nut, bearing balls, and spacers remain stationary in relation to output shaft. Teeter tail rotor and verify bearing outer races do not move inside hub.
 - c. If bearing outer races rotate within hub bore, insufficient clamp-up is indicated. Replace tail rotor hub.
5. Install hardware securing tail rotor blades to pitch links as removed, or as determined by static balancing. Standard torque nuts & palnuts per § 23-32, and torque stripe per Figure 2-1.
6. Install C119-2 bumper, A141-14 washer, and nut. Standard torque nut per § 23-32 and torque stripe per Figure 2-1.
7. Dynamically balance tail rotor per § 10.240.

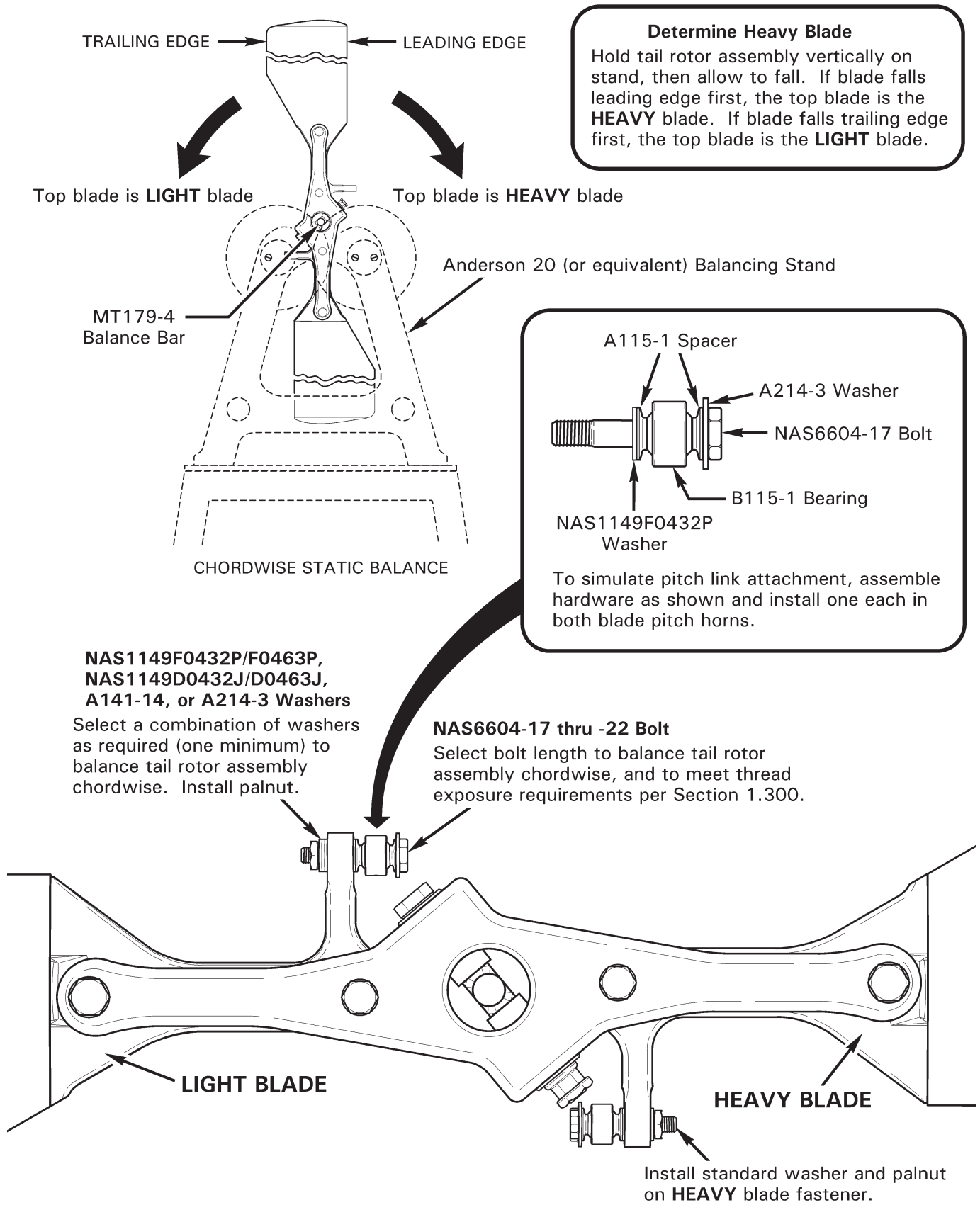

FIGURE 30-3 CHORDWISE STATIC BALANCE
 (C008-9 Tail Rotor Assembly Shown)

30-11 Static Balance

NOTE

Tail rotor assembly received from RHC was statically-balanced at factory.

A. Chordwise Static Balance

1. Refer to Figure 30-3. Install MT179-4 balance bar into tail rotor assembly. Install teeter hinge bolt, tighten until bearing spacers firmly clamp bar, and install palnut finger-tight. Using a carpenter's square, adjust balance bar until approximately perpendicular to hub.
2. Place tail rotor assembly with balance bar on Anderson 20 or equivalent balancing stand. Adjust pitch of both blades so they are similar. Hold tail rotor assembly vertically, then allow to fall. If the blade falls leading edge first, the top blade is the heavy blade. If the blade falls trailing edge first, the top blade is the light blade.
3. To simulate pitch link attachment, assemble hardware as shown and install in blade pitch horns. Install standard washer and palnut on heavy blade fastener.
4. Chordwise balancing is achieved by varying NAS6604 bolt length and nut-side washers on light blade fastener. Select bolt length and washers for balancing, and to meet thread exposure requirements per § 23-30. Repeat step 2.
5. Blades are balanced chordwise when blade does not fall when positioned vertically on balancing stand. Repeat step 4, adjusting bolts and washers until blades are balanced within one thin washer.
6. Perform spanwise static balance per § 30-11 Part B.

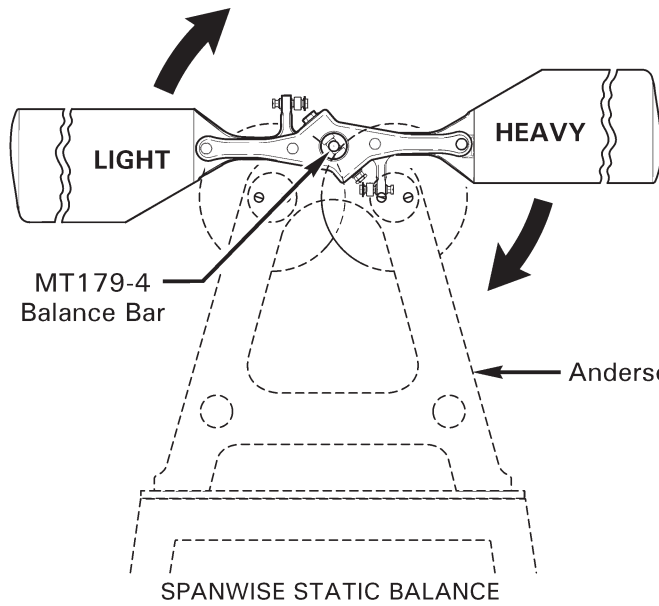

Determine Heavy Blade
 Hold tail rotor assembly horizontally on stand, then allow to fall. The falling blade is the **HEAVY** blade; the rising blade is the **LIGHT** blade.

(4) NAS1149F0632P/F0663P, NAS1149D0632J/D0663J, C141-23, or C141-24 Washers

Select a combination of four washers to balance tail rotor assembly spanwise. Place largest washers closest to hub assembly.

C008-9 TAIL ROTOR ASSEMBLY

Install (4) NAS1149D0663J washers under nut of **HEAVY** blade outboard fastener for initial spanwise static balance check.

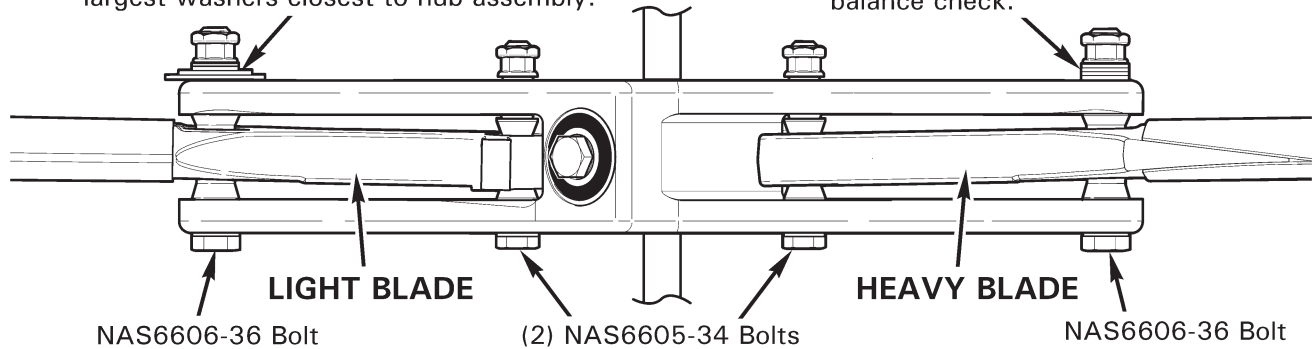

NAS6606-36 Bolt

(2) NAS6605-34 Bolts

NAS6606-36 Bolt

(4) NAS1149D0532K/D0563K, NAS1149F0563P/AN970-5, or A141-20 Washers
 See above description.

C008-4 TAIL ROTOR ASSEMBLY

(4) NAS1149D0563K
 See above description.

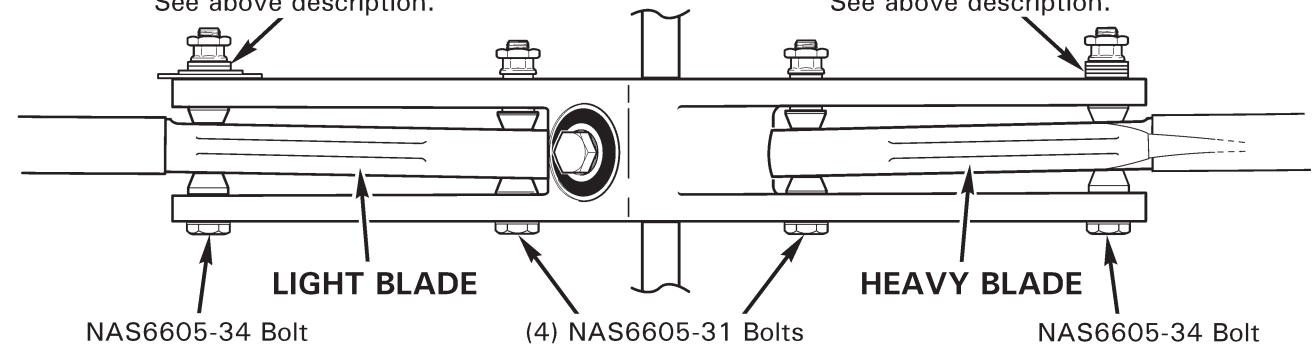

NAS6605-34 Bolt

(4) NAS6605-31 Bolts

NAS6605-34 Bolt

FIGURE 30-4 SPANWISE STATIC BALANCE

30-11 Static Balance (continued)**B. Spanwise Static Balance****CAUTION**

Verify four washers installed under each blade's outboard fastener prior to tail rotor assembly installation or dynamic balance.

1. Refer to Figure 30-4. Install standard hardware for initial spanwise static balance check. Standard torque fasteners per § 23-32.
2. Install MT179-4 balance bar into tail rotor assembly. Install teeter hinge bolt, tighten until bearing spacers firmly clamp bar, and install palnut finger tight. Using a carpenter's square, adjust balance bar until approximately perpendicular to hub.
3. Place tail rotor assembly with balance bar on Anderson 20 or equivalent balancing stand. Hold tail rotor assembly horizontally, then allow to fall. The falling blade is the heavy blade; the rising blade is the light blade.
4. Spanwise balancing is achieved by varying nut-side washer size on light blade outboard fastener. Four washers are required under outboard fastener nuts; place largest washers closest to hub assembly. Select washers for balancing, standard torque hardware per § 23-32, and repeat step 3.
5. Blades are balanced spanwise when blade does not fall when positioned horizontally on balancing stand. Repeat step 4, adjusting outboard fastener washers until blades are balanced.
6. Recheck chordwise and spanwise balance. Tail rotor assembly must be statically balanced within one thin washer. Remove MT179-4 balance bar.
7. Touch-up bolt heads using approved paint (see § 23-70).

30-20 Tail Rotor Blades**NOTE**

Protect tail rotor assembly from damage when maintenance is performed on workbench.

A. Removal

1. Remove tail rotor assembly per § 30-10.
2. Refer to Figure 30-1 or Figure 30-2. Mark three-piece tail rotor hub assembly across the hub and plates for reinstallation.
3. Remove hardware securing tail rotor blades to hub assembly. Remove blades, spacers, and hardware. Remove bushings if required.

B. Installation**CAUTION**

C029 tail rotor blades are a matched set from RHC. If only one blade is being replaced, contact RHC Customer Service with airworthy blade serial number for a matching replacement blade.

1. Inspect tail rotor hub per § 30-40, as required.
2. Refer to Figure 30-1 or Figure 30-2. If removed, apply light coat of approved primer (see § 23-70) to outer surface of bushings; while primer is wet, press bushings flush with inboard side of hub inboard arm (bushings will seat properly with fastener torque applied).

CAUTION

The longer spacer creates blade precone angle and must be installed on the outboard side of blade, on the blade outboard (spanwise) fitting.

3. Install tail rotor blades and spacers in hub. Assemble blades (if viewed from left side of aircraft) for clockwise rotation, to cone toward tail rotor gearbox. Install hardware securing blades to hub; install standard hardware on outboard fasteners for initial tail rotor assembly static balance check. Standard torque bolts per § 23-32, and torque stripe inboard bolts per Figure 2-1.
4. Perform tail rotor assembly static balance per § 30-11.

Intentionally Blank

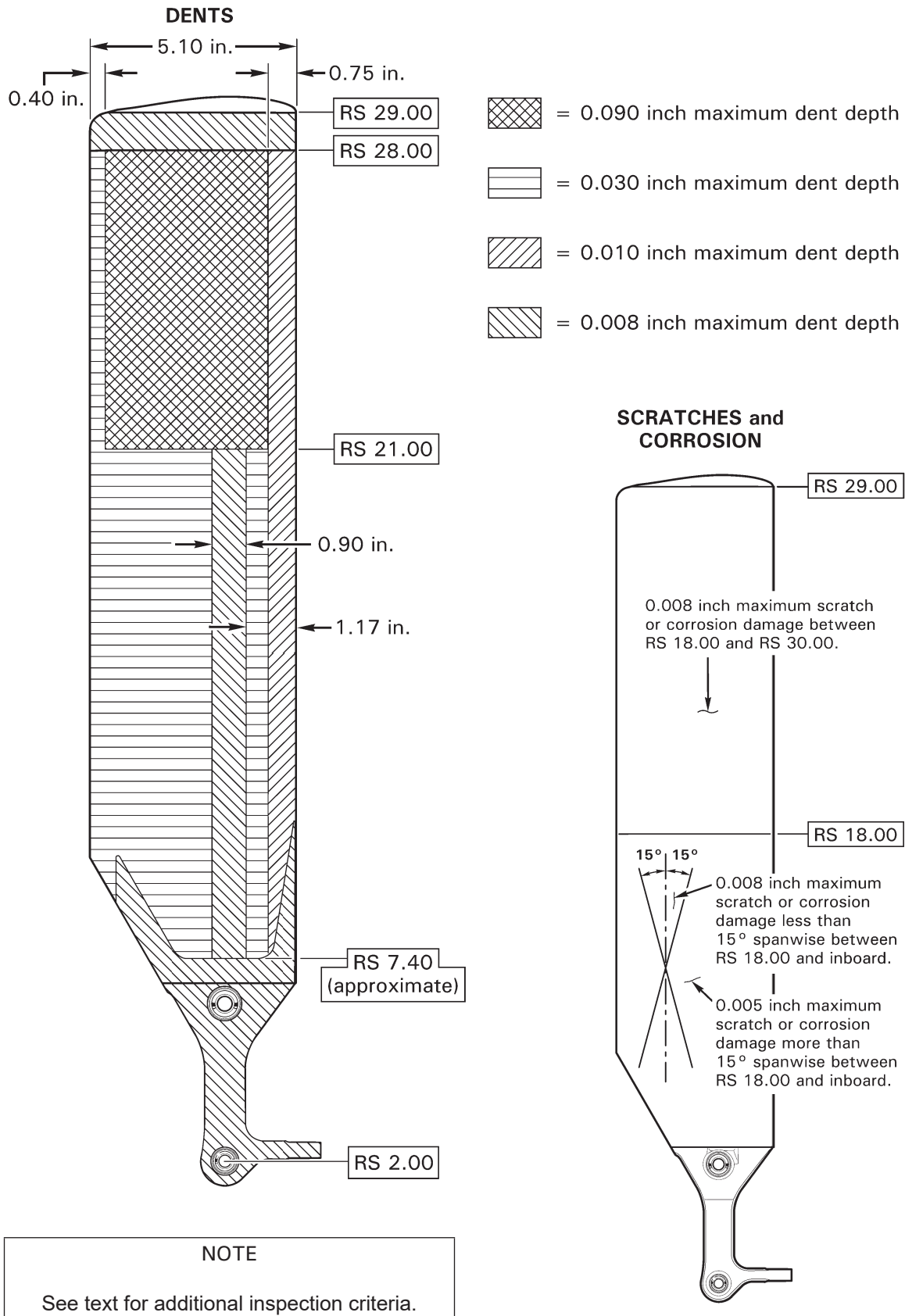

FIGURE 30-5 TAIL ROTOR BLADE INSPECTION CRITERIA

30-30 Tail Rotor Blade Inspection and Repair

This blade repair procedure outlines the repair limits, methods and materials used for repairing tail rotor blades. Repairs are limited to blending out scratches, dents, nicks, removing corrosion, and refinishing the blades. The inspections, repairs and limitations contained herein refer to damage sustained in service, including damage during shipping and handling (manufacturing irregularities are treated separately by the factory). In-service damage will generally exhibit paint scuffing or scratches and often times freshly-exposed metal in the form of scratches in the finish. If there are any questions as to the possibility of a manufacturing irregularity, contact RHC Technical Support.

CAUTION

A blade may be repaired more than one time. However, in no case can more than the maximum material be removed or the maximum dent depth be exceeded in any one location.

Refer to § 28-40 for measuring blade damage.

30-31 Scratches and Corrosion

1. Refer to Figure 30-5. Verify damage does not exceed the following limits:
 - a. 0.008 inch maximum damage between RS 18.00 and RS 29.00.
 - b. 0.005 inch maximum damage more than 15° spanwise between RS 18.00 and inboard.
 - c. 0.008 inch maximum damage less than 15° spanwise between RS 18.00 and inboard.
2. Refer to § 28-50 (main rotor) for repair procedures for damage within limits. Blend out scratches or corrosion on skins with a minimum 0.10 inch blend radius.

30-32 Dents**CAUTION**

Tap-test dented areas in honeycomb. If any voids are found associated with dents, replace blade.

Tap-test voids, debonds, and dents in blades using an AN970-4 washer or 1965, or later, U.S. quarter-dollar coin in good condition.

CAUTION

When dented areas are found, inspect opposite side of the blade for a bulge. Replace blade with a bulge greater than 0.010 inch opposite a dent.

CAUTION

Do not repair any dent that has a sharp cut or break in the skin. If necessary, locally penetrant inspect, keeping penetrant materials away from bond joints.

WARNING

Any damaged tail rotor blade that cannot be repaired within the limits of this section must be removed from service immediately and marked "scrap."

A. Skins

1. Refer to Figure 30-5. Smooth, round bottom dents with 0.060 inch minimum radius may be repaired when damage does not exceed the following limits:
 - a. 0.010 inch maximum depth between leading edge and 0.75 inch aft (chordwise).
 - b. 0.75 inch aft (chordwise) of leading edge:
 - i. 0.090 inch maximum dent depth between RS 21.00 and RS 29.00.
 - ii. 0.030 inch maximum dent depth between RS 21.00 and inboard.
 - c. 0.030 inch maximum depth between trailing edge and 0.40 inch forward (chordwise).
 - d. 0.008 inch maximum depth between RS 28.00 and RS 29.00.
 - e. 0.008 inch maximum depth over the skin-to-root fitting bond joint and inboard honeycomb.
2. Refer to § 28-50 (main rotor) for repair procedures for damage within limits.

30-33 Erosion

Replace any blade where erosion has caused deformation or ripples in the leading edge.

30-34 Root Fitting Damage

1. Verify damage does not exceed the following limits:
 - a. No repairs permitted within 1.5-inch diameter circle from center of spherical bearing.
 - b. 0.040 inch maximum depth on other root fitting exposed areas.
2. Refer to § 28-50 (main rotor) for repair procedures for damage within limits. Blend out root fitting damage with a minimum 1.0 inch blend radius.

30-35 Nicks and Notches**A. Trailing Edge**

1. Verify damage does not exceed the following limits:
 - a. 0.050 inch maximum in the extreme trailing edge.
2. Refer to § 28-50 (main rotor) for repair procedures for damage within limits. Blend out nicks and notches in blade trailing edge for 1.0 inch minimum each side of nick or notch.

C029-3 Tail Rotor Blades

C029-1 and -2 Tail Rotor Blades

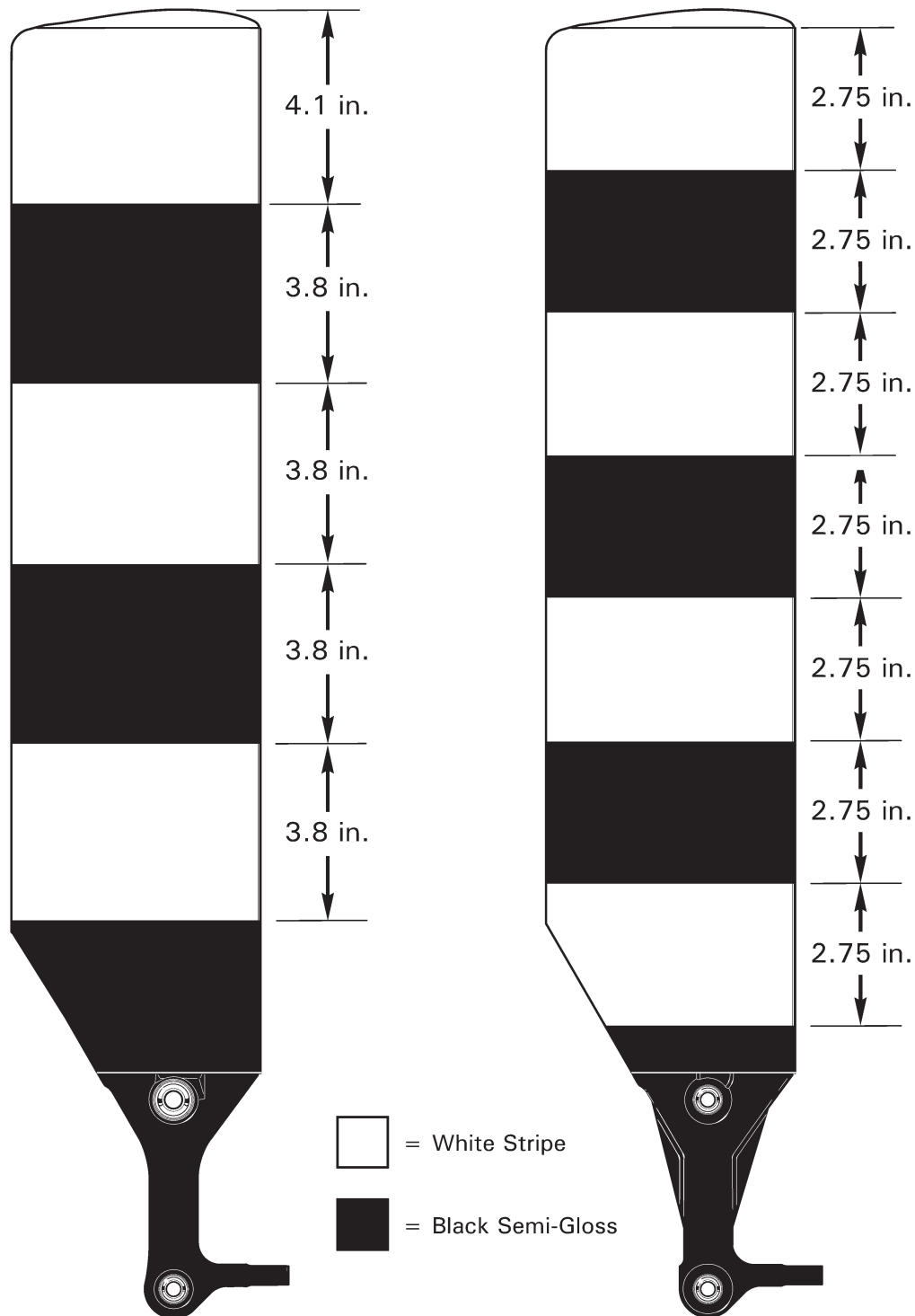
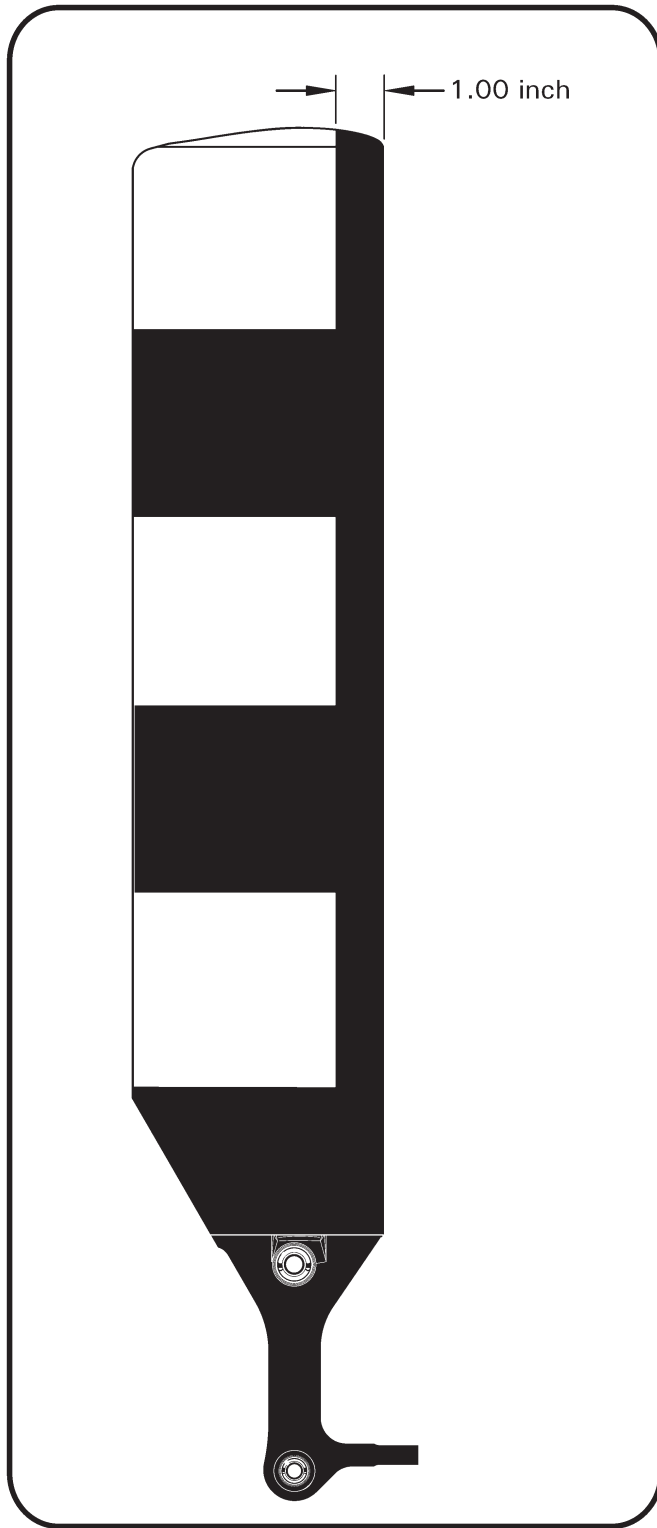

FIGURE 30-6 TAIL ROTOR BLADE PAINT SCHEME

30-36 Painting

1. Clean with QSOL 220 and wipe lint-free with a tack rag.
2. Apply a 2 to 3-inch wide strip of epoxy primer along all exposed bond joints.
3. Apply two full coats of epoxy primer to all exterior surfaces. Time limits are 10 minutes minimum, 8 hours maximum between coats. If 8 hours is exceeded, scuff with 600 grit wet-or-dry aluminum oxide abrasive paper in a spanwise direction, QSOL 220 wipe and mist primer before applying next coat.
4. Spray white all over and allow to dry before masking for trim stripes. See Figure 30-6.
5. Spray finish coat semi-gloss black stripes and root fitting.
6. Remove all masking materials.



30-7A TAIL ROTOR BLADE LEADING EDGE PAINT

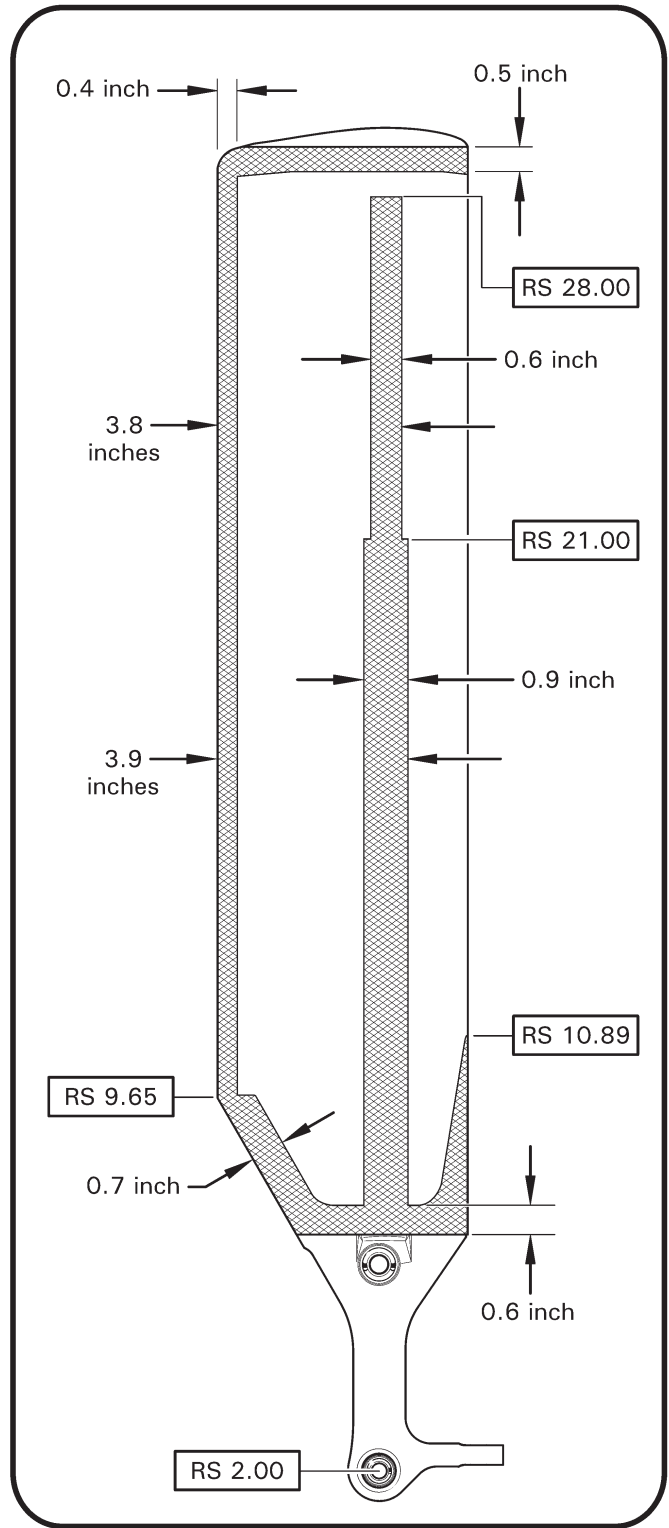

30-7B TAIL ROTOR BLADE BONDED AREAS

30-37 Tail Rotor Blade Condition and Care

Regular preventive maintenance of tail rotor blades is imperative for continued safe operation. Leading edge pitting or degradation of the bond at the tip cap can result if regular preventive maintenance is not performed; additional care may be required in corrosive environments such as coastal or shipboard operations. The following maintenance is recommended to prevent and mitigate the effects of corrosion:

1. Remove any corrosion and loose paint by hand-sanding in a spanwise direction using 220-grit aluminum-oxide abrasive paper and minimum 0.1 inch blend radius; finish sand with 320-grit aluminum-oxide abrasive paper. Remove only material necessary to eliminate corrosion; any hole that completely penetrates blade skin requires blade replacement.

Feather edge of paint bordering any bare metal by hand-sanding spanwise with 320-grit or finer wet-or-dry aluminum-oxide abrasive paper. Do not remove bare metal when feather sanding.

Preferred blade condition is with fully painted leading edge. Use two coats of Desoprime CA7502 epoxy primer (or equivalent). Scuff primer prior to applying second coat. Use Dupont Imron polyurethane enamel or equivalent paint. Refer to § 23-77 for specific paint codes. Blades with striped leading edges may be painted with solid black leading edge (ref. Figure 30-7A) if desired for ease of application.

Paint offers the best protection against leading edge corrosion. If painting blades is impractical, at least a single coat of primer on leading edges provides some protection.

2. Balance tail rotor per § 10.240 after any corrosion removal or painting.
3. When operating in a corrosive environment, even if leading edge paint/primer is intact, clean tail rotor daily per applicable Pilot's Operating Handbook Section 8, Cleaning Helicopter (mild soap means a pH between 7 & 9). If waxing blades is impractical, wipe blade leading edges with standard WD-40® brand light oil or equivalent; do not use ACF-50® lubricant or "Specialist" versions of WD-40® on blades, and do not use Salt-Away®.
4. Refer to Figure 30-7B. At each 100-hour inspection, tap test bonded areas shown to verify bond integrity, paying special attention to tip cap. Reference tap test instructional video at: https://robinsonheli.com/wp-content/uploads/2021/06/taptest_05_apr_2010.mp4

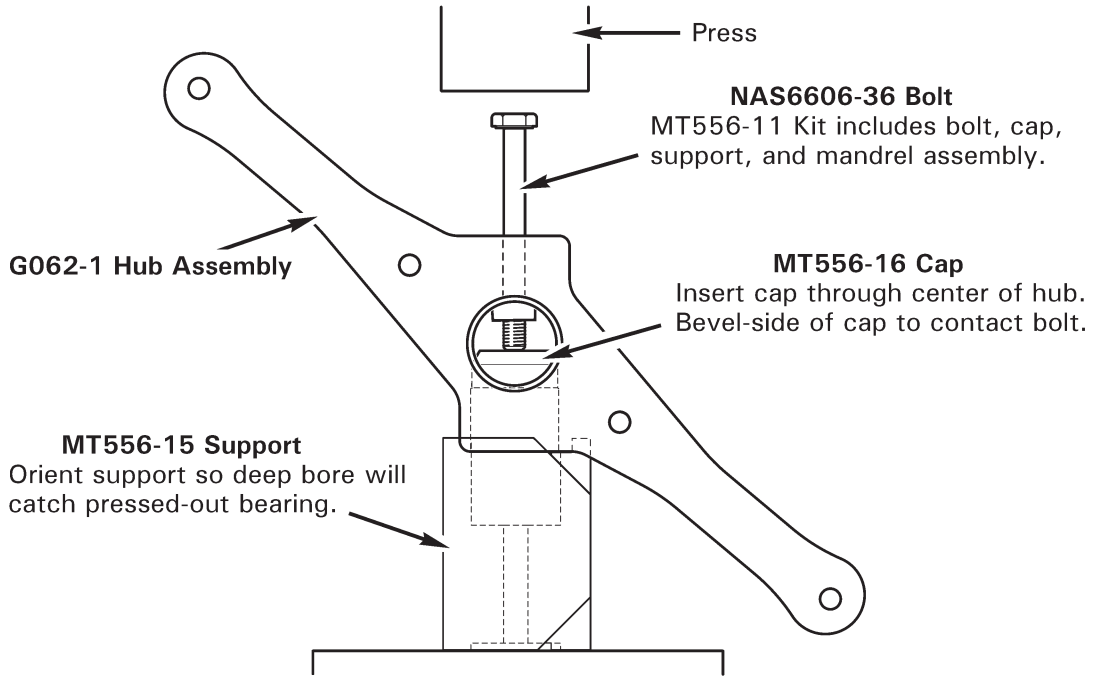

FIGURE 30-8 ELASTOMERIC BEARING REMOVAL

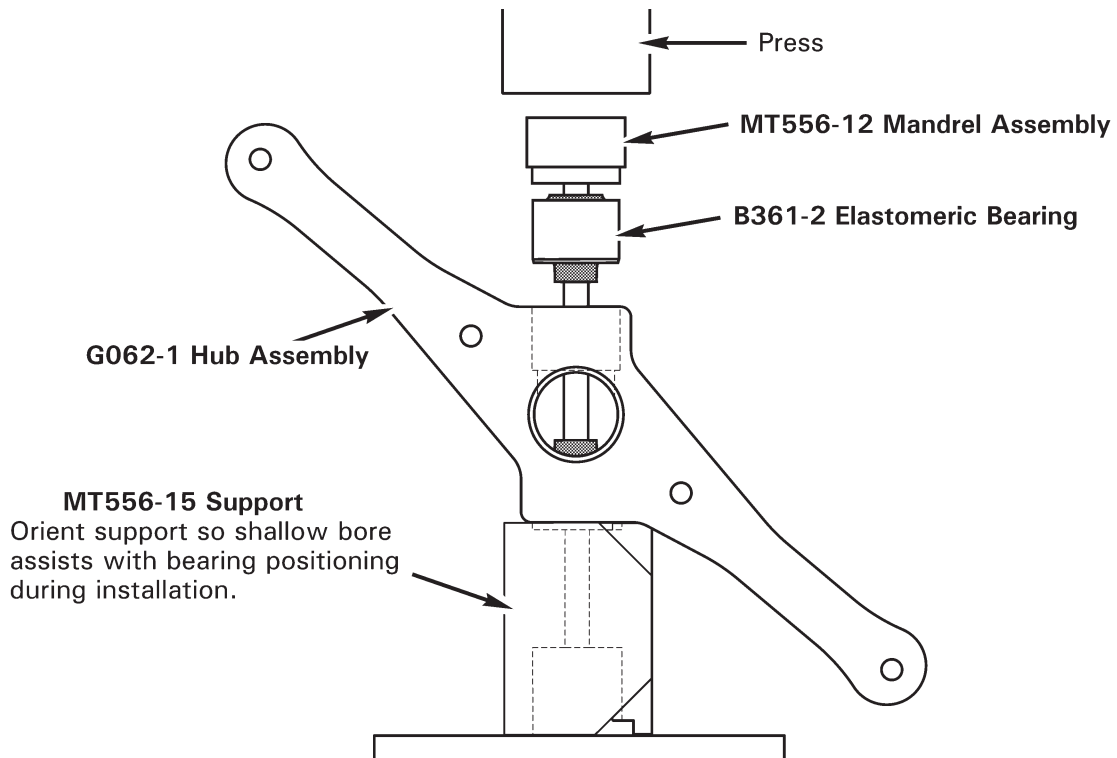

FIGURE 30-9 ELASTOMERIC BEARING INSTALLATION

30-40 Tail Rotor Hub

30-41 Elastomeric Bearing Replacement

A. Removal

1. Remove tail rotor assembly per § 30-10.
2. Remove tail rotor blades per § 30-20.
3. Refer to Figure 30-8. Press bearing(s) from hub using MT556-11 bearing removal (and installation) tools.

B. Installation

1. Inspect tail rotor hub per § 30-43.

<p style="text-align: center;">CAUTION</p>

<p>Bearings are a slight press fit in tail rotor hub bores. Inspect bores for fretting; if fretting is detected, hub is unairworthy.</p>
--

2. Refer to Figure 30-9. Using Q-tip, apply light coat of approved primer (see § 23-70) to bottom of hub bearing bore. Apply a thin line of primer to center of bearing outside diameter. While primer is wet, press bearing into hub using MT556-11 bearing removal and installation tools. Wipe away excess primer.
3. Repeat steps for second bearing, as required.

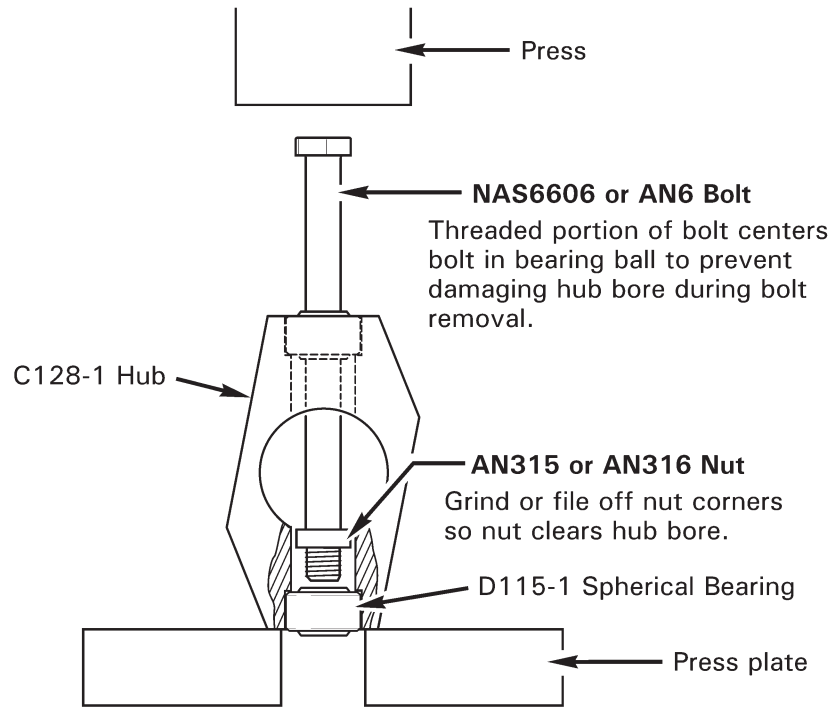

FIGURE 30-10 SPHERICAL BEARING REMOVAL

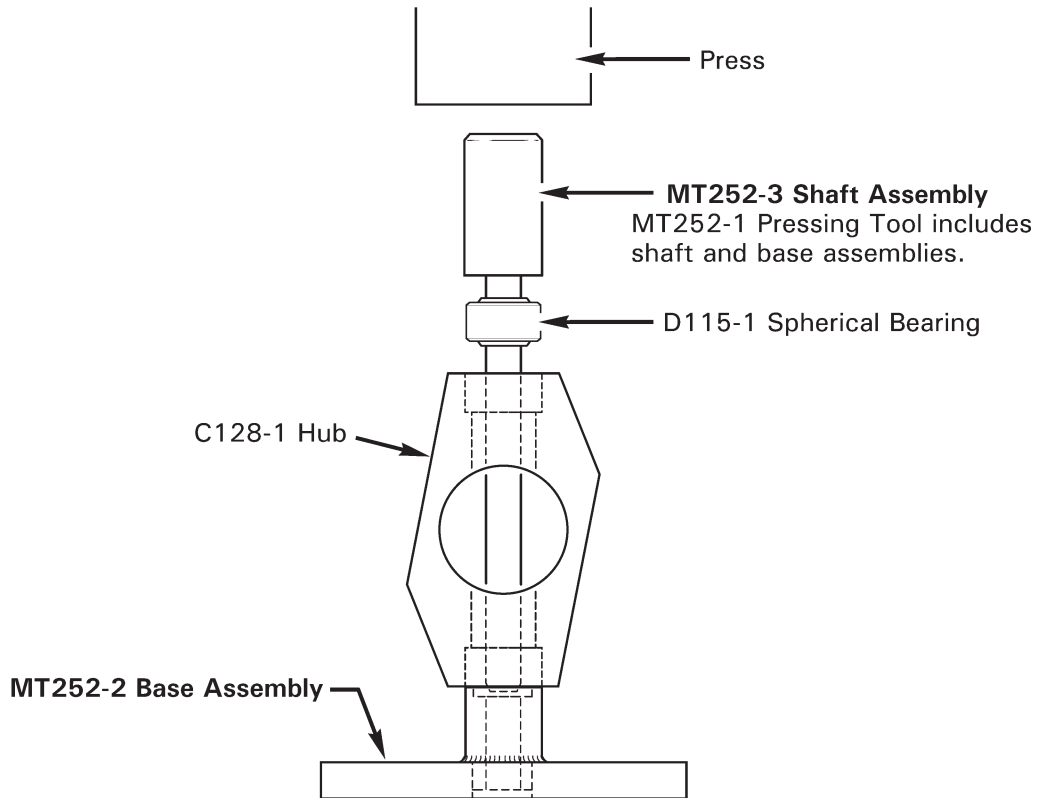

FIGURE 30-11 SPHERICAL BEARING INSTALLATION

30-42 Spherical Bearing Replacement

A. Removal

1. Remove tail rotor assembly per § 30-10.
2. Remove tail rotor blades per § 30-20.
3. Refer to Figure 30-10. Press bearing(s) from hub as shown.

B. Installation

1. Inspect tail rotor hub per § 30-43.

CAUTION

Bearings are a slight press fit in tail rotor hub bores. Inspect bores for fretting; if fretting is detected, hub is unairworthy.

NOTE

Heat tail rotor hub to 170° F maximum as required to facilitate bearing installation and help prevent installation damage.

NOTE

Immediately install tail rotor assembly before bearing-bore primer cures.

NOTE

If spherical bearings are installed too far into hub, spacers and hub will not fit over gearbox output shaft.

2. Refer to Figure 30-11. Using Q-tip, apply light coat of approved primer (see § 23-70) to bottom of hub bearing bore. Apply a thin line of primer to center of bearing outside diameter. While primer is wet, press bearing flush with top of hub using MT252-1 bearing installation tools. Wipe away excess primer.
3. Repeat steps for second bearing, as required.
4. Align marked line and install hub between hub plates as removed. Install hardware, standard torque nuts & palnuts per § 23-32, and torque stripe per Figure 2-1.
5. Install tail rotor blades per § 30-20.

30-43 Tail Rotor Hub Inspection

1. Remove tail rotor blades per § 30-20, if not previously accomplished. Inspect blades per § 30-30.
2. Remove teeter bearings per §§ 30-41 or 30-42, as appropriate.
3. Clean tail rotor hub using approved solvent (see § 23-70). Remove old primer and/or metal shavings from hub which might prevent new bearings from seating properly.
4. Visually inspect for indications of damage, wear, nicks, dings, and corrosion. Verify arm straightness, no elongation of bolt holes, and no fretting or galling of bearing bores. Corrosion is not permitted.
5. Touch-up bare metal using approved materials (see § 23-70).
6. Install new teeter bearings per §§ 30-41 or 30-42, as appropriate.
7. Install tail rotor blades per § 30-20.

CHAPTER 31

TAIL ROTOR DRIVE SYSTEM

<u>Section</u>	<u>Title</u>	<u>Page</u>
31-00	Description	31.1

Intentionally Blank

CHAPTER 31**TAIL ROTOR DRIVE SYSTEM**31-00 Description

Reserved.

Intentionally Blank

CHAPTER 32

ENGINE CONTROLS

<u>Section</u>	<u>Title</u>	<u>Page</u>
32-00	Description	32.1

Intentionally Blank

CHAPTER 32**ENGINE CONTROLS**32-00 Description

Reserved.

Intentionally Blank

CHAPTER 33
ENGINE OIL SYSTEM

<u>Section</u>	<u>Title</u>	<u>Page</u>
33-00	Description	33.1

Intentionally Blank

CHAPTER 33**ENGINE OIL SYSTEM**33-00 Description

Reserved.

Intentionally Blank

CHAPTER 34

POLICE VERSION

<u>Section</u>	<u>Title</u>	<u>Page</u>
34-00	Description	34.1

Intentionally Blank

CHAPTER 34**POLICE VERSION**34-00 Description

Reserved.

Intentionally Blank

CHAPTER 35

E.N.G. VERSION

<u>Section</u>	<u>Title</u>	<u>Page</u>
35-00	Description	35.1

Intentionally Blank

CHAPTER 35**E.N.G. VERSION**35-00 Description

Reserved.

Intentionally Blank

CHAPTER 36**CADET VERSION**

<u>Section</u>	<u>Title</u>	<u>Page</u>
36-00	Dimensions and Descriptions	36.1
36-10	Access Panels	36.3
36-20	Placards and Markings	36.3
36-30	Environment Control	36.5
36-40	Furnishings	36.7
36-41	Carpet	36.7
36-42	Insulation (Foam and Headliner)	36.7
36-50	Doors and Windows	36.8
36-60	Instruments	36.9
36-70	Avionics	36.10

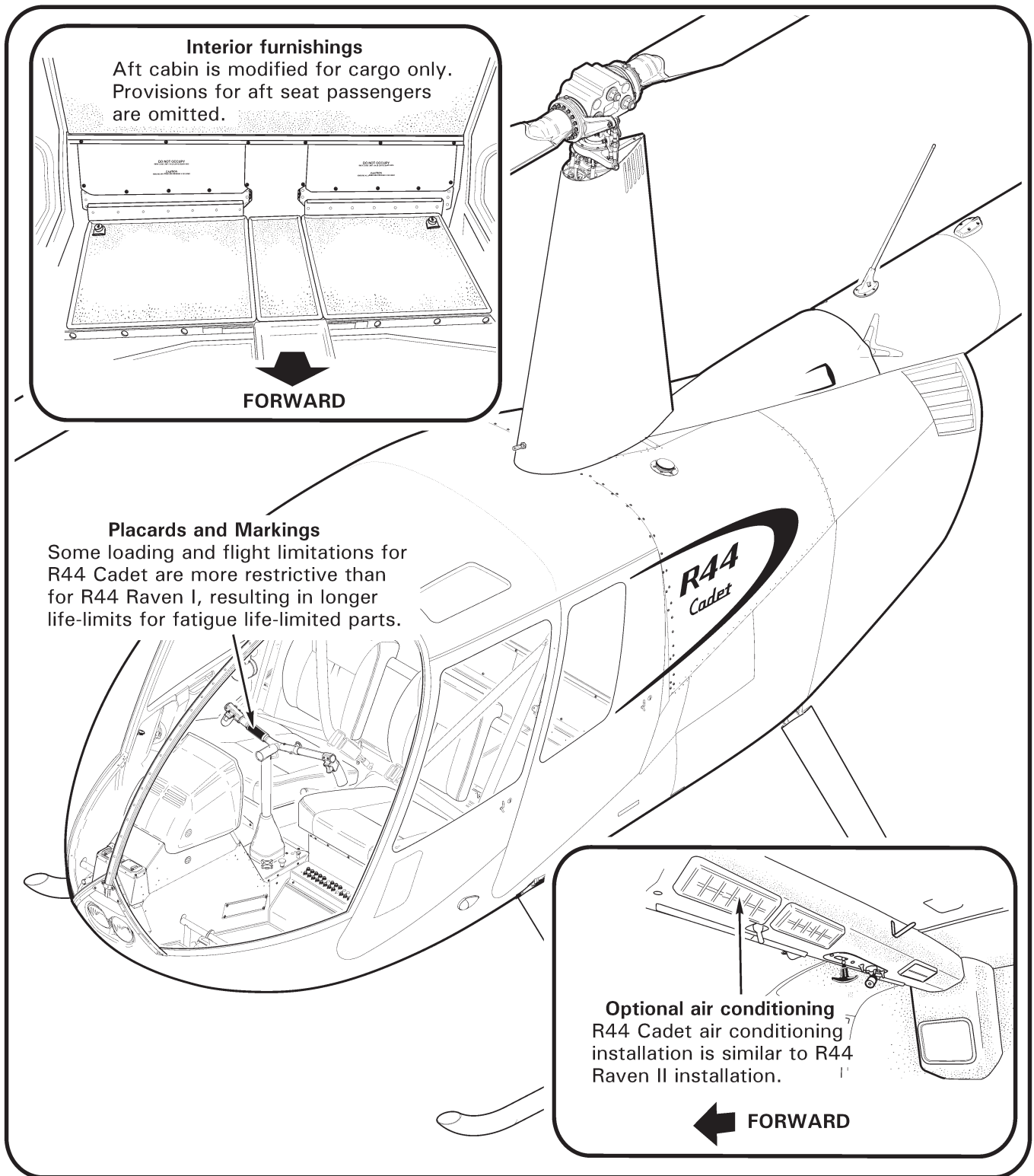

FIGURE 36-1 CADET CONFIGURATION

CHAPTER 36
CADET VERSION

36-00 Dimensions and Descriptions

A. Dimensions

Refer to § 16-40 for external dimensions.

B. Description

Refer to § 16-10 for version description.

Refer to Figure 36-1. The R44 Cadet is a two-place R44 Raven I helicopter with the aft cabin modified for cargo only. Standard equipment includes a Lycoming O-540 six-cylinder, carbureted engine and a 28-volt DC electrical system.

Some loading and flight limitations for R44 Cadet are more restrictive than for R44 Raven I, resulting in improved performance margins as well as extended TBO times for overhaul parts, and longer life-limits for fatigue life-limited parts (refer to Chapter 3 for Airworthiness Limitations).

Air conditioning is optional equipment for R44 Cadet.

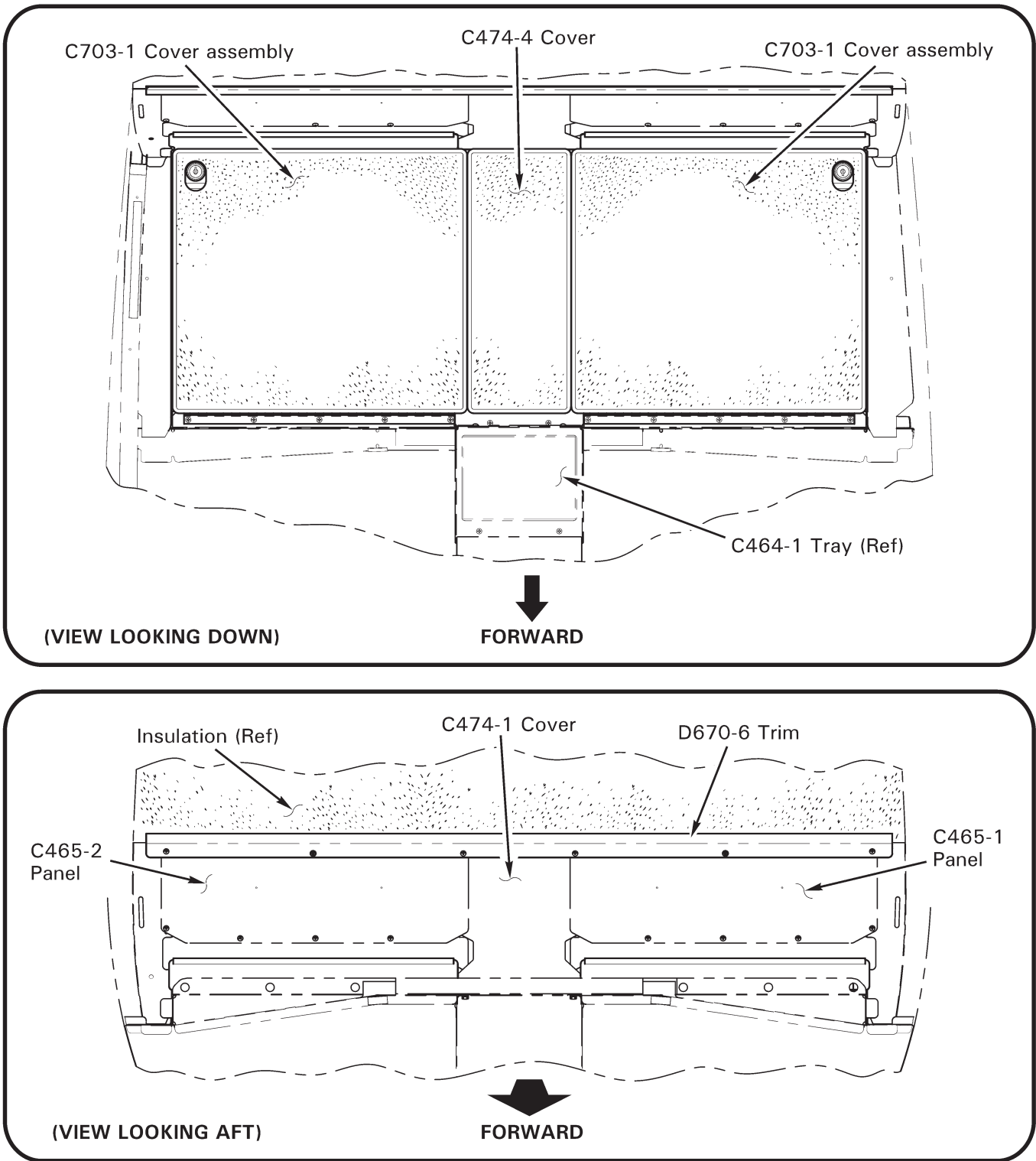

FIGURE 36-2 AFT CABIN ACCESS PANELS

36-10 Access Panels

A. Dimensions

R44 Cadet access panels are similar to R44 Raven I installation. Refer to R44 Illustrated Parts Catalog (IPC) Figure 94-1 for R44 Cadet configuration.

B. Control Tunnel Access

1. Refer to Figure 36-2. Open C703-1 cover assemblies, remove screws securing C474-4 (horizontal) cover to cabin, and remove cover.
2. Remove screws securing D670-6 trim to C465 panels and remove trim.
3. Remove screws securing C474-1 (vertical) cover to cabin and remove cover.

C. Bulkhead Access

1. Refer to Figure 36-2. Remove screws securing D670-6 trim to C465 panels and remove trim.
2. Lift up insulation as required, remove screws securing C465 panels to cabin, and remove panels.

36-20 Placards and Markings

A. Description

R44 Cadet paint, marking, and decal installation is similar to R44 Raven I installation. Refer to R44 Illustrated Parts Catalog (IPC) Figure 94-1 for R44 Cadet configuration.

B. Removal

Start at corners and slowly peel off decal by hand or using a plastic wedge. Avoid damaging or removing paint or primer from surfaces. Remove decal entirely.

C. Installation

Verify surfaces are clean and dry before attaching decals. Use a clean cloth wet with acetone or mild soapy water to clean surfaces. Press decal to surface and verify security.

<p style="text-align: center;">CAUTION</p>

<p>Use caution when using acetone near silk-screened lettering. Acetone can smudge or remove silk-screened letters.</p>

D. Scheduled Maintenance

Inspect placards every 100-hour/annual inspection per § 2.400.

Intentionally Blank

36-30 Environment Control**A. Description**

R44 Cadet air conditioning installation is similar to R44 Raven II installation. Refer to R44 Illustrated Parts Catalog Figure (IPC) 94-1 for R44 Cadet configuration.

B. Maintenance

Refer to § 11.300 for maintenance procedures.

C. Schematic

Refer to Figures 11-4 & 11-4A for air conditioning schematic. |

D. Scheduled Maintenance

Inspect air conditioning components every 100-hour/annual inspection per § 2.400.

E. Special Maintenance

Refer to § 11.310 for air conditioning system troubleshooting.

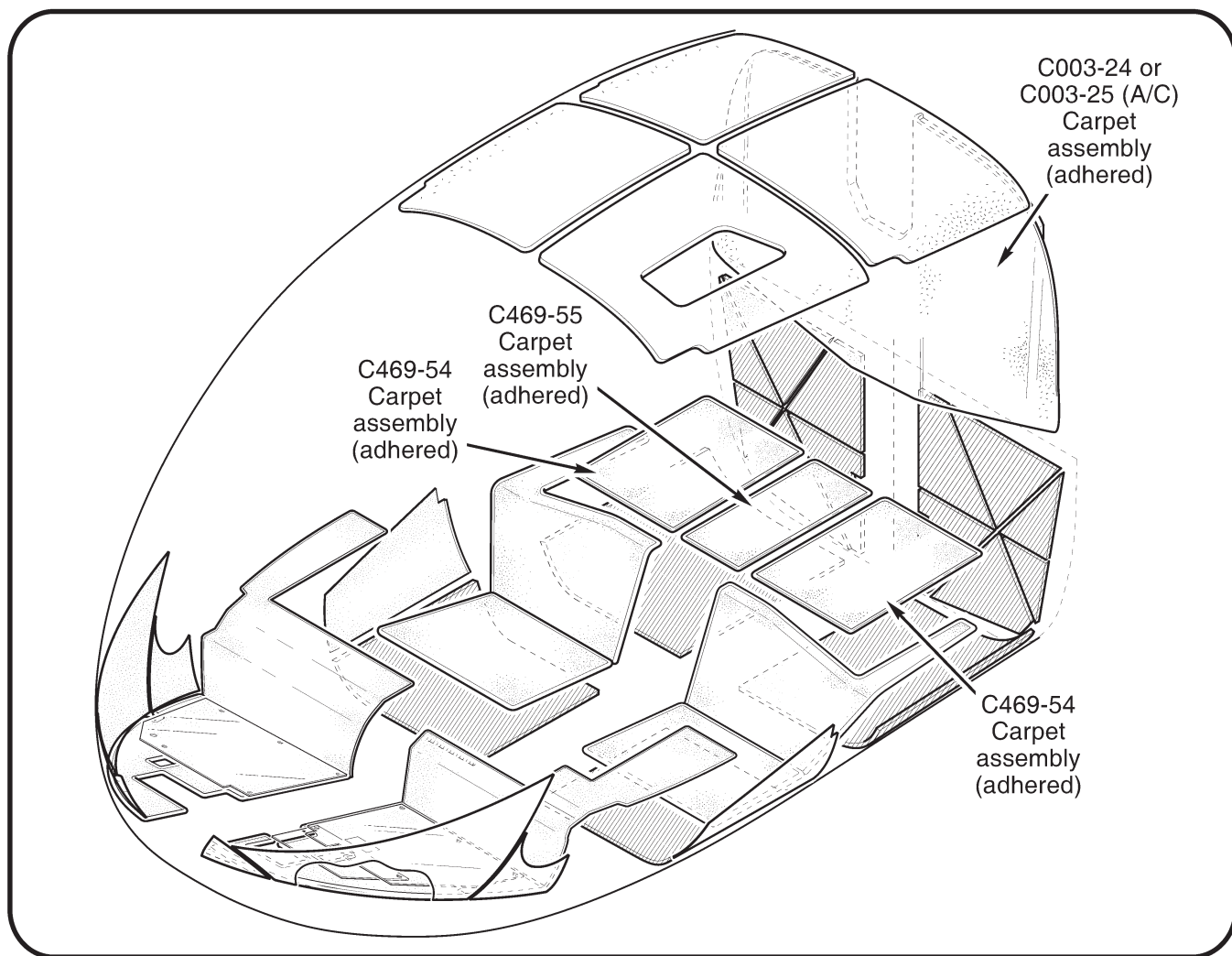

FIGURE 36-4 CARPET AND INSULATION

36-40 Furnishings

A. Description

R44 Cadet aft cabin is similar to R44 Raven I installation but provisions for aft seat passengers are omitted. Refer to R44 Illustrated Parts Catalog Figure (IPC) 94-1 for R44 Cadet configuration.

B. Maintenance

Refer to § 16-60 for access panels.

36-41 Carpet

A. Description

R44 Cadet carpet installation is similar to R44 Raven I installation; carpet is also installed on C703-1 cover assemblies. Refer to R44 Illustrated Parts Catalog Figure (IPC) 94-1 for R44 Cadet configuration.

B. Maintenance

Refer to Figure 36-4 and § 15.320 for adhered carpet removal and installation.

36-42 Insulation (Foam and Headliner)

A. Description

R44 Cadet insulation installation is similar to R44 Raven II installation; insulation at aft bulkhead is modified for omitted backrests. Refer to R44 Illustrated Parts Catalog Figure (IPC) 94-1 for R44 Cadet configuration.

B. Maintenance

Refer to Figure 36-4 (observe notes for specific parts) and § 15.400 for insulation | and headliner replacement.

36-50 Doors and Windows**A. Description**

R44 Cadet cabin door installation is identical to R44 Raven I and II installations; aft doors have been modified for cargo-only aft cabin. Refer to R44 Illustrated Parts Catalog Figure (IPC) 94-1 for R44 Cadet configuration.

B. Removal

Refer to R44 Illustrated Parts Catalog (IPC) Chapter 52.

1. To disconnect door from gas spring mechanism:
 - a. Forward Doors: Pull rod up and off of arm assembly ball joint.
 - b. Aft Doors: Insert flat-tip screwdriver and pry up spring clip locking gas spring to channel ball joint. Pull gas spring up and off of ball joint.
2. Remove rings from door hinge pins, lift pins up from door frame hinge assemblies, and remove door.

C. Installation**WARNING**

Failure to install a ring in each door's two hinge pins may allow door to depart aircraft in flight.

1. Align and insert door hinge pins in door frame hinge assemblies.
2. Align forward door rod with arm assembly ball joint, or aft door gas spring with channel ball joint, and push down to lock.
3. Install rings in door hinge pins.

D. Scheduled Maintenance

Inspect doors and door installation every 100-hour/annual inspection per § 2.400.

36-60 Instruments

A. Description

R44 Cadet instrument installation is identical to R44 Raven I installation but the manifold gage and airspeed indicator have different range markings. Refer to R44 Illustrated Parts Catalog Figure (IPC) 94-1 for R44 Cadet configuration.

B. Removal

CAUTION

Protect instrumentation using foam padding or equivalent.
Handle instruments like eggs.

1. Remove perimeter screws securing instrument face to console and pull face aft.
2. As applicable, disconnect pitot and static lines from instrument; temporarily cap fittings at instrument and in aircraft to prevent contamination.
3. Supporting instrument, remove screws (use a non-magnetic tool) securing instrument to face, and remove instrument (place on foam padding).

C. Installation

CAUTION

Protect instrumentation using foam padding or equivalent.
Handle instruments like eggs.

1. Pull instrument face aft. Position instrument in face and install screws (use a non-magnetic tool). Verify security.
2. As applicable, remove temporary fitting caps and connect pitot and static lines to instruments. Verify security. Perform pitot & static line leak check per § 13-10.
3. Install perimeter screws securing face to console.

D. Scheduled Maintenance

Inspect instruments every 100-hour/annual inspection per § 2.400.

E. Special Maintenance

Troubleshoot as required per Chapter 13.

36-70 Avionics

A. Description

R44 Cadet audio system is similar to R44 Raven I installation but provisions for aft seat passengers are omitted. Refer to R44 Illustrated Parts Catalog Figure (IPC) 94-1 for R44 Cadet configuration.

B. Removal

1. Turn battery switch off and pull out AUDIO PANEL circuit breaker (2 amp) at panel.
2. Open instrument console. Loosen screws and disconnect instrument console connector from B338-2 ICS control.
3. Loosen set screws securing volume and squelch knobs to ICS control and remove knobs.
4. Supporting control, remove screws securing face plate to lower panel and ICS control. Remove ICS control and plate.

C. Installation

1. Turn battery switch off and pull out AUDIO PANEL circuit breaker (2 amp) at panel.
2. Open instrument console. Position B338-2 ICS control inside console on lower panel. Install screws securing face plate to panel and ICS control. Verify security.
3. Connect instrument console connector to ICS control and tighten connector screws. Verify security. Close and secure instrument console.
4. Index volume and squelch knobs on ICS control and tighten set screws. Verify security.
5. Push in AUDIO PANEL circuit breaker (2 amp) at panel. Turn battery switch on. Test each headset jack and transmit triggers for proper function. Turn battery switch off.

D. Schematic

Refer to Figure 14-29 or 14-30 for audio system electrical schematic.

E. Scheduled Maintenance

On condition.

F. Special Maintenance

1. Turn battery switch off. Open circuit breaker panel and instrument console.
2. Inspect condition of and verify no obvious damage to audio control, circuit breaker, and wiring. Verify no loose, chafed, or broken wires or terminals. Verify no evidence of arcing. Verify equipment security.
3. Secure circuit breaker panel and instrument console. Perform ground check per Part C step 5.

CHAPTER 37**ELECTRICAL SYSTEM**

<i>Section</i>	<i>Title</i>	<i>Page</i>
37-00	Description	37.1
37-10	Battery	37.2
37-11	Lead-Acid Battery Installation	37.2
37-12	Lithium-Ion Battery Installation	37.2B
37-20	RPM Governor	37.3
37-30	Clutch Actuator	37.3
37-40	Lighting System	37.4
37-50	External Power Receptacle (Optional)	37.4
37-60	Audio System	37.5
37-70	Warning and Caution Lights	37.5
37-80	Carbon Monoxide Detector	37.8
37-90	Emergency Locator Transmitter (ELT)	37.8
37-100	Low Rotor RPM Warning System	37.9
37-110	Troubleshooting	37.11
37-120	Electrical Load Analysis	37.21
37-130	Audio Alerts	37.33
37-140	Cockpit Camera	37.33
37-150	Overspeed Protection	37.34
37-160	Lycoming Electronic Ignition System (EIS)	37.34

Intentionally Blank

CHAPTER 37

ELECTRICAL SYSTEM

37-00 Description

This section contains information for correcting difficulties that may arise in the electrical system. It includes a general description and some test and adjustment procedures.

14-volt electrical systems include a 14-volt, 70-ampere capacity alternator (limited to 50 amps continuous), battery relay, alternator control unit and 12-volt battery.

28-volt electrical systems include a 28-volt, 70-ampere capacity (limited to 64 amps continuous) alternator, battery relay, alternator control unit, and 24-volt battery. A 130-amp capacity alternator, limited to 85 amps continuous, is standard on the Police version.

The battery is in a fiberglass container located on the lower left steel tube frame, in the nose under the upper console, or in the left-front baggage compartment. Police and E.N.G. versions have the battery suspended from the tailcone.

Circuit breakers are located on the ledge just forward of the left-front seat. The breakers are marked to indicate their function and amperage and are of the push-to-reset type.

The master battery switch, located on the console, controls the battery relay, which disconnects the battery from all circuits except the tachometer and the clock. The tachometer and the clock also receive power directly from the battery via a Clutch switch terminal.

The alternator control unit (ACU) senses system voltage at the ammeter shunt via a remote sense wire. The 14-volt ACU has three functions: it regulates alternator output voltage to maintain a battery voltage of 13.7-13.9 volts, it warns of low-voltage by illuminating the ALT warning light if voltage decreases to 12.55-12.95 volts, and it protects against over-voltage by shutting off alternator field if voltage increases to 15.75-16.25 volts. The 28-volt ACU also has three functions: it warns of low-voltage by illuminating the ALT warning light if voltage decreases to 24.00-26.00 volts, it protects against over-voltage by shutting off alternator field if voltage increases to 32.00-33.40 volts, and it regulates alternator output voltage by modulating field current within a 0.25-1.00 volt window centered at 28.25-28.75 volts. This allows alternator output to more closely follow electrical load demands and reduces voltage fluctuations.

In addition to a circuit breaker, the clutch actuator circuit incorporates a low-amperage fuse to prevent a motor overload from tripping the circuit breaker and turning off the CLUTCH light prematurely, and to prevent motor burnout due to prolonged motor overload. This also results in drive belt overtensioning protection. A time delay is also included in the circuit to prolong actuator spring switch life, and to prevent overtensioning due to spring switch flutter resulting from excessive vibration. The time delay affects gearmotor operation only during Engage cycle; the time delay does not affect CLUTCH light operation and does not function during Disengage cycle. The time delay allows gearmotor operation 0.25 seconds after circuit completion (indicated by CLUTCH light illumination). Any circuit interruption

37-00 Description (continued)

(indicated by CLUTCH light extinguishing) instantly resets the time delay.

The lighting system includes the anti-collision light, navigation lights, two landing lights, post and internal lights for instruments and an overhead map light. Landing lights are wired through the clutch switch, turning the lights off when disengaged. Post and internal instrument light brightness is adjustable via a wire-wound rheostat on early 14-volt ships, or via an electronic dimmer on later 14-volt and all 28-volt ships. The electronic dimmer will shut down if encountering a short-to-ground circuit; dimmer will reset when short is cleared.

Warning lights on the instrument panel include clutch, low oil pressure, low fuel, main rotor and tail rotor gearbox chip lights, main rotor gearbox over-temp, engine fire (sensor activates at 275 ± 10 °F), low rotor RPM light, low voltage (ALT), rotor brake, and starter engaged. R44 IIs additionally include fuel filter, aux fuel pump, and carbon monoxide warning lights.

The gage cluster includes an ammeter, oil pressure, oil temperature, cylinder head temperature and main and auxiliary fuel quantities. Also provided on this circuit are the carburetor air temperature (O-540 only) and outside air temperature. The map light is on the same breaker as a back-up in the event of a short and failure of the lighting system circuit.

The tachometer is an electronic engine and rotor dual tachometer. The sensor for the engine tach is a contact assembly (breaker points) in the engine-right magneto (helicopter left side). A Hall Effect sensor for, and receiving power from, the rotor tachometer senses passage of two magnets on the main rotor gearbox input yoke. Signals from these sensors are conditioned by solid state circuits inside the dual tachometer. Each tachometer circuit has a separate circuit breaker and is completely independent of the other. They can be powered by either the alternator or the battery and receive current from two redundant sources. Power to the tachometer is interrupted only when the master battery and alternator switches are off and the clutch switch is disengaged. All tachometers operate on 14 volts; 28-volt ships utilize two voltage regulators to change 28 volts to the 14 volts required by both tachometers.

CAUTION

The installation of electrical devices can affect the accuracy and reliability of the electronic tachometer; therefore, no electrical equipment may be installed in the R44 helicopter unless that particular installation is specifically approved by the factory.

CAUTION

When installing upper console, ensure multi-pin connectors are matched correctly. Both halves of number 1 connector have a white stripe. Crossing connections will result in damage to electrical system.

37-00 Description (continued)

E.N.G. and Police versions each have an additional, right-side circuit breaker panel on the ledge just forward of the pilot's seat containing all circuit breakers for the optional E.N.G. or police equipment. The forward row of circuit breakers is connected to a 28-volt bus. The aft row of circuit breakers is connected to a 14-volt bus on E.N.G. versions while on police versions the outboard section of the aft row of circuit breakers is connected to a 14-volt bus. The 14-volt bus is powered by a 28- to 14-volt converter. A separate Master switch on the left side of the circuit breaker panel controls power to all E.N.G. or police equipment.

37-10 Battery

37-11 Lead-Acid Battery Installation

NOTE

Refer to Concorde Battery Corporation's Owner/Operator's Manual, and Instruction for Continued Airworthiness for battery maintenance procedures.

CAUTION

Use insulated tools when performing maintenance near battery.

CAUTION

To minimize risk of electrical discharge: When disconnecting battery, disconnect negative (ground) cable from battery first, then the positive cable. When connecting battery, connect positive cable to battery first, then the negative (ground) cable.

A. Disconnecting and Removing Battery

1. Turn battery switch off.
 - a. Aft Battery: Remove engine left-hand side cowling. Loosen clamp securing cooling hose to battery cover assembly and disconnect hose. Remove cotter rings and wing nuts to release rods attaching battery cover to lower frames. Remove battery cover.
 - b. Under-seat battery: Pivot forward left-hand seat forward and remove C748-5 cover assembly. Remove hardware securing D144-6 hold-down assembly to cabin and remove hold-down assembly.
 - c. Tailcone-mounted battery: Remove screws securing D540-3 or -5 box and remove box from tailcone. Loosen but do not remove (4) NAS6604-3 bolts securing D362-10 straps. While holding battery, pull (forward) strap forward and slowly tilt battery to gain access to terminals.
2. Remove hardware securing negative (ground) cable to battery negative terminal.
3. Remove hardware securing positive cable to battery positive terminal. Carefully remove battery.

37-11 Lead-Acid Battery Installation (continued)**B. Installing and Connecting Battery**

1. Turn battery switch off.
2. Aft Battery: Verify installation and good condition of G405-2 bumpers (or D832-1 neoprene strips, if installed) on C046-26 lower frame.
3. Position battery in helicopter and connect positive cable to battery first, then connect the negative (ground) cable. Special torque terminal bolts per § 23-33 and torque stripe per Figure 2-1. Position positive cable's nipple over terminal.
4. Under-seat battery: Install hardware securing D144-6 hold-down assembly to cabin so it just contacts top of battery (holes are slotted; adjust as required). Standard torque bolt per § 23-32 and torque stripe per Figure 2-1.
5.
 - a. Aft Battery: Position battery cover assembly on battery and install wing nuts and cotter rings to secure rods attaching battery cover to lower frames. Connect cooling hose to battery cover and tighten clamp. Verify security. Install engine left-hand side cowling.
 - b. Under-seat battery: Install C748-5 cover assembly and pivot forward left-hand seat aft.
 - c. Tailcone-mounted battery: Position D362-10 straps under battery, standard torque (4) NAS6604-3 bolts securing straps. Position D540-3 or -5 box on tailcone and install screws, verify security.

37-12 Lithium-Ion Battery Installation

A. Description

A 17 amp-hour lithium-ion battery replaces the standard 24-volt lead-acid main battery. The lithium-ion battery includes built-in circuitry that monitors temperature, voltage, and current draw and manages battery charge and discharge. The circuitry automatically disables charge and/or discharge if any electrical or thermal problems are detected. The circuitry will also interrupt power if a start is attempted with insufficient charge to prevent permanent battery damage. The battery uses lithium-iron-phosphate chemistry which is less susceptible to thermal runaway than some other lithium battery chemistries.

The metal battery case is designed to contain any heat or gases generated within the battery and is vented overboard. No venting should occur during normal operation.

Two annunciator panel segments, BATT FAULT and BATT HEATER, show battery status. The annunciator panel test button should cause these segments to illuminate along with the rest of the annunciator panel. The segments will also illuminate briefly when the battery switch is turned on after several hours of inactivity.

BATT FAULT illuminates if the battery has an over- or under-voltage condition, an over-temperature condition, or if current draw exceeds limits. A flashing light indicates a recoverable fault. The light may go out if the fault corrects itself (e.g. temperature decrease) or may go out as a result of a power cycle at the next landing. A steady light indicates battery maintenance or replacement may be required. The emergency procedure for a fault light (flashing or steady) is to land as soon as practical. The alternator will continue to supply electrical power during the landing.

The battery incorporates an internal heater for cold weather operation. The heater attempts to maintain a battery temperature of at least 50°F (10°C). When the battery is switched ON, BATT HEATER illuminates while the heater is warming the battery and extinguishes when the battery is warm enough to attempt an engine start. On very cold days, the heating cycle may take 10 minutes or more. The heater light is disabled while the engine is running but the heater will continue to function as long as the battery switch is ON.

Nominal charging voltage for the lithium-ion battery is 28.8 volts. Some lead-acid chargers may not provide enough voltage to fully charge the battery. Ensure charging equipment is compatible with lithium-ion batteries.

37-12 Lithium-Ion Battery Installation

A. Description (continued)

NOTE

Refer to True Blue Power Installation Manual and Operating Instructions for battery maintenance procedures.

CAUTION

Use insulated tools when performing maintenance near battery.

CAUTION

To minimize risk of electrical discharge: When disconnecting battery, disconnect negative (ground) cable from battery first, then the positive cable. When connecting battery, connect positive cable to battery first, then the negative (ground) cable.

B. Disconnecting and Removing Battery

1. Turn battery switch off.
 - a. Aft Battery: Remove engine left-hand side cowling. Loosen clamp securing cooling hose to battery cover assembly and disconnect hose. Remove cotter rings and wing nuts to release rods attaching battery cover to lower frames. Remove battery cover.
 - b. Under-seat battery: Pivot forward left-hand seat forward and remove C748-5 cover assembly. Remove hardware securing D144-10 hold-down assembly to cabin and remove hold-down assembly.
2. Loosen clamp securing vent hose to battery and pull hose off of battery.
3. Disconnect F693 harness assembly from battery's comm connector.
4. Remove hardware securing negative (ground) cable to battery negative terminal.
5. Remove hardware securing positive cable to battery positive terminal. Carefully remove battery.

37-12 Lithium-Ion Battery Installation (continued)

C. Installing and Connecting Battery

1. Perform pre-installation inspection and completely charge battery per True Blue Power Installation Manual and Operating Instructions. If battery is new, also perform visual inspection, charging, capacity check, and return to service per True Blue Power Installation Manual and Operating Instructions.
2. Turn battery switch off. Position battery in helicopter.
3. Verify battery terminal surfaces are clean to ensure electrical conductivity. Install positive cable on battery positive terminal and install battery hardware. Special torque terminal bolt per § 23-33 and torque stripe per Figure 2-1. Slide nipple over terminal.
4. Install negative (ground) cable on battery negative terminal and install battery hardware. Special torque terminal bolt per § 23-33 and torque stripe per Figure 2-1.
5. Connect F693 harness assembly to battery's comm connector.
6. Connect vent hose to battery outlet and tighten clamp. Verify security.
7.
 - a. Aft Battery: Position battery cover assembly on battery and install wing nuts and cotter rings to secure rods attaching battery cover to lower frames. Connect cooling hose to battery cover and tighten clamp. Verify security. Install engine left-hand side cowling.
 - b. Under-seat battery: Install hardware securing D144-10 hold-down assembly to cabin so it just contacts top of battery (holes are slotted; adjust as required). Standard torque bolt per § 23-32 and torque stripe per Figure 2-1. Install C748-5 cover assembly and pivot forward left-hand seat aft.

D. Scheduled Maintenance and Inspections

Every 6 Months: If battery is unused for more than 6 months, either installed in helicopter or in storage, completely charge battery per True Blue Power Installation Manual and Operating Instructions.

Every 24 Months: Perform visual inspection, charging, capacity check, and return to service per True Blue Power Installation Manual and Operating Instructions every 24 months from date of aircraft delivery or subsequent new battery installation.

E. Special Maintenance and Inspections

No other battery maintenance other than routine maintenance specified by True Blue Power is permitted.

Operators are encouraged to review important safety information regarding handling, shipping, storage instructions, estimated unit life, and disposal instructions provided in True Blue Power Installation Manual and Operating Instructions.

Note: In accordance with industry and regulatory standards, the TB17 Lithium-ion battery will be shipped with a state of charge (SOC) not to exceed 30% of rated capacity.

37-20 RPM Governor

The governor maintains engine RPM by sensing changes and applying corrective throttle inputs through a friction clutch which can be easily overridden by the pilot. The governor is only active above 80% engine RPM and can be switched on or off using the toggle switch on the end of the right seat collective.

The governor is designed to assist in controlling RPM under normal conditions. It may not prevent over- or under-speed conditions generated by aggressive flight maneuvers.

CAUTION

When operating at high density altitudes, governor response rate may be too slow to prevent overspeed during gusts, pull-ups, or when lowering collective.

37-30 Clutch Actuator

After the engine is started, it is coupled to the rotor drive system through vee-belts which are tensioned by raising the upper drive sheave. An electric actuator, located between the drive sheaves, raises the upper sheave when the pilot engages the clutch switch. The actuator senses compressive load (belt tension) and switches off when the vee-belts are properly tensioned. The clutch caution light illuminates whenever the actuator circuit is energized, either engaging, disengaging, or re-tensioning the belts. The light stays on until the belts are properly tensioned or completely disengaged.

Belt slack during engine start should be adjusted such that blades begin turning within five seconds of clutch engagement. Excessive slack may cause belts to jump out of sheave grooves during start. Periodic readjustment by a mechanic may be required as belts wear in service.

A fuse located on or near the test switch panel prevents an actuator motor overload from tripping the circuit breaker. If the fuse blows, the actuator motor will stop but the clutch caution light will remain illuminated. An open circuit breaker removes power from both the motor and the light. With an open circuit breaker, no belt tensioning will occur, and the light will not function to indicate an abnormal condition.

CAUTION

Never take off while clutch caution light is on.

37-40 Lighting System

A red anti-collision light is installed on the tailcone and is controlled by the strobe switch. Position lights are installed on each side of the cabin and in the tail and are controlled by the nav lights switch. Post and internal lights (earlier aircraft) or a light at the top of the windshield (later aircraft) illuminate the instruments. Instrument lighting is active when the nav lights switch is on and lighting is dimmed via the knob above the nav lights switch. An overhead map light mounted on a swivel is controlled by an adjacent switch. The map light may be used for emergency lighting of the instrument panel.

Two landing lights are installed in the nose at different vertical angles to increase the lighted area. One landing light switch controls both lights and is located on the cyclic center post.

NOTE

Landing lights operate only when clutch actuator switch is in the engage position.

NOTE

Continuous operation of landing and position lights in flight is recommended to promote collision avoidance.

An optional flashing light may be mounted on the tailcone in addition to the standard anti-collision light. On earlier aircraft, the optional light is controlled by the strobe switch and the standard light is powered whenever the battery switch is on. On later aircraft, the optional light is controlled by a separate switch.

37-50 External Power Receptacle (Optional)

An optional 28-volt MS3506-compatible external power receptacle is located inside the right engine cowl door. When the battery is switched on, the external power relay and the battery relay both close, connecting external power to the aircraft electrical system and battery. The external power relay will not close if reverse polarity is sensed by the receptacle.

A separate wire from the external power receptacle to the battery bypasses the external power and battery relays. This wire allows battery charging via the external receptacle with the battery switch off. A 10-amp circuit breaker at the receptacle opens if current exceeds normal charging levels, and a diode provides polarity protection.

To use ground power for engine starting, have ground personnel connect ground power to the external receptacle prior to engaging starter, disconnect after engine start, and latch cowl door. Starts using ground power assist follow the same procedure as normal starts.

37-60 Audio System

A voice-activated intercom/audio system is standard and is controlled by a small control panel above the avionics stack. The ICS volume knob controls intercom volume but does not affect radio volume. The VOX squelch knob is used to set the threshold volume at which the intercom is activated. When the VOX knob is turned fully clockwise, keying is required to activate the intercom.

On R44s and R44 IIs, a toggle switch allows selection of PILOT ISO mode in which the pilot is connected only to the radio while the copilot and rear passengers remain connected to each other via the intercom.

A music input jack is located on the aft seat console on R44s and R44 IIs, or located on a panel between the seat back rests on R44 Cadets. This input is muted when the intercom is active, when transmitting, and during reception of radio signals.

Headset jacks are located in the ceiling. The cyclic grips are equipped with either transmit and intercom buttons or trigger-style intercom/transmit switches. For the trigger-style switch, the first detent activates the intercom and second detent transmits. For R44s and R44 IIs, additional intercom buttons are located inboard of the rear seats and on the left forward floor or seat support. For R44 Cadets, an additional intercom button is located on the outboard side of the left seat.

Audio control panels from several manufacturers are offered as options in place of the standard intercom system. Pilots should consult the manufacturer's operating instructions if an audio panel is installed.

37-70 Warning and Caution Lights

Warning and caution lights include clutch, main gearbox over-temperature, main and tail gearbox chip, engine fire, starter on, low fuel, fuel filter (R44 IIs), auxiliary fuel pump (R44 IIs), low RPM, alternator, low oil pressure, rotor brake, carbon monoxide, governor off, and full throttle (later aircraft). The clutch light indicates that the clutch actuator is operating. The low RPM light and horn indicate rotor RPM at 97% or below. The engine fire light is actuated by a temperature switch located at the forward end of the horizontal firewall. The low oil pressure and low fuel lights are actuated by sensors in those systems and are independent of the gage indicators. The alternator light warns of a possible alternator failure. The auxiliary fuel pump light monitors fuel pressure from the auxiliary pump and illuminates due to pump failure or when the clutch switch is not engaged. The fuel filter light warns of possible filter contamination. The governor-off light indicates the RPM governor is switched off.

The main and tail gearbox chip detectors are magnetic devices located in the drain plug of each gearbox. When metallic particles are drawn to the magnets they close an electrical circuit, illuminating the caution light. Metal particles may be caused by a failing bearing or gear, thus giving warning of impending gearbox failure. The main gearbox over-temp light is actuated by a temperature switch located near the input pinion.

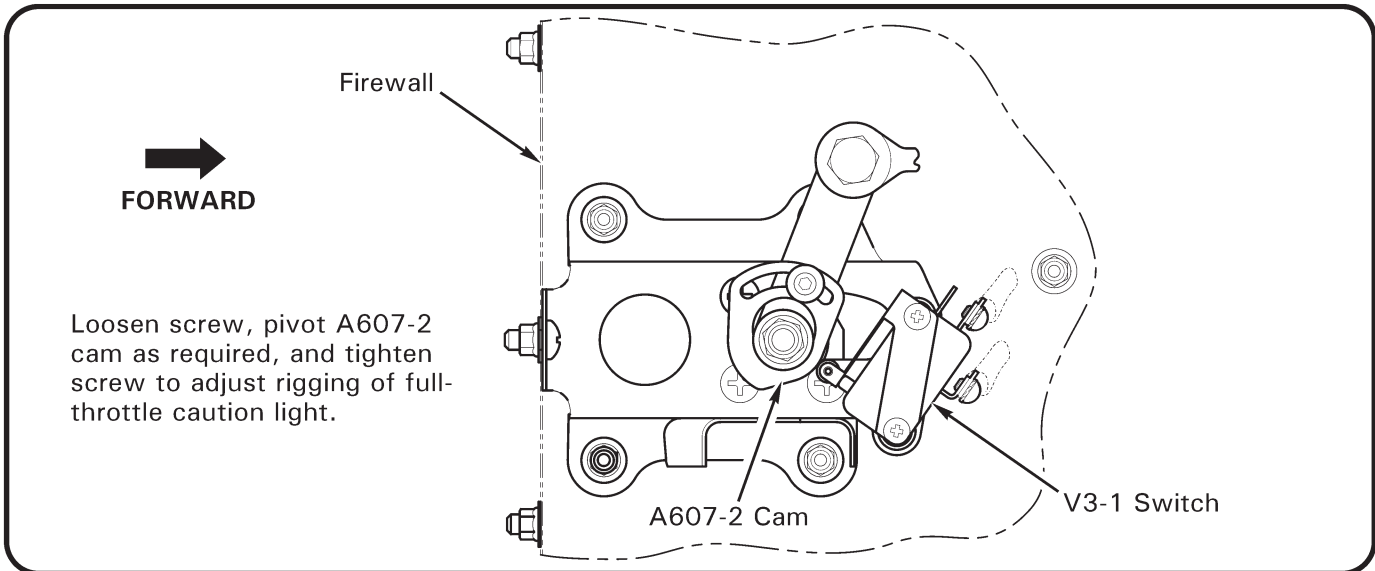
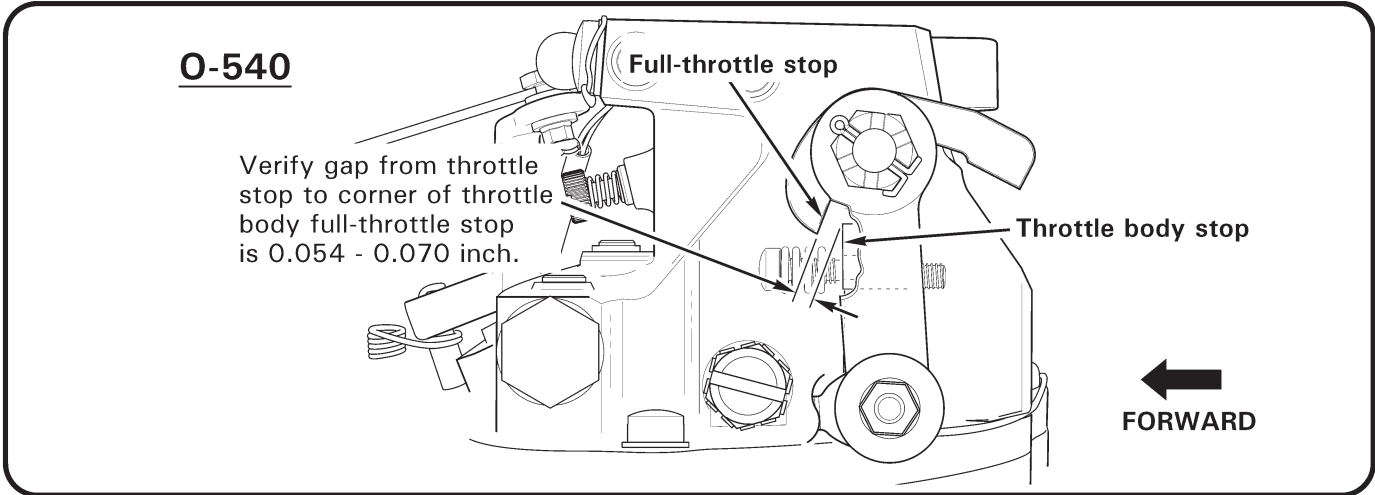
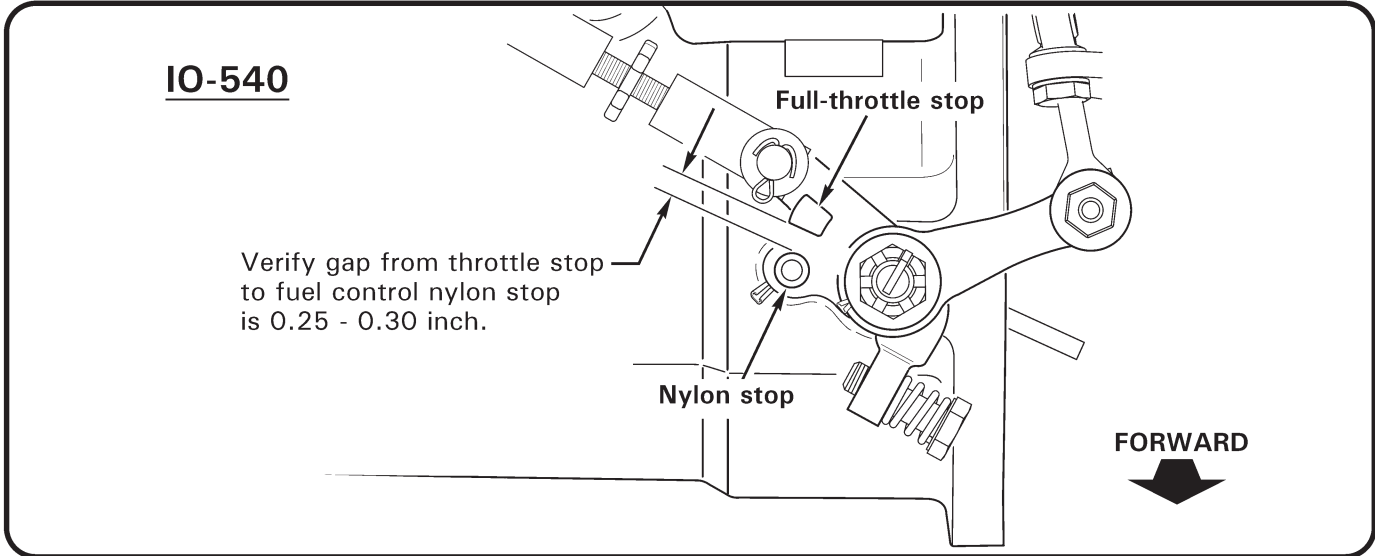

FIGURE 37-1 FULL THROTTLE CAUTION LIGHT RIGGING CHECK

37-70 Warning and Caution Lights (continued)

The carbon monoxide light is actuated by a sensor above the pilot's heater outlet and indicates elevated cabin carbon monoxide levels.

The full throttle light is activated by a switch in the throttle linkage and indicates that the engine is near full throttle.

A. Full Throttle Caution Light

1. Switch Rigging Check

- a. Turn fuel shut-off valve off.
- b. Turn battery switch on. Raise collective full up and slowly rotate twist grip open until full throttle caution light just illuminates.
- c.
 - i. **IO-540:** Refer to Figure 37-1. Verify gap from throttle stop to fuel control nylon stop is 0.25–0.30 inch. Adjust switch as required per step 2.
 - ii. **O-540:** Refer to Figure 37-1. Verify gap from throttle stop to corner of throttle body full-throttle stop is 0.054–0.070 inch. Adjust switch as required per step 2.
- d. Lower collective & turn battery switch off. Turn fuel shut-off valve on.

2. Switch Adjustment

- a.
 - i. **IO-540:** Refer to Figure 37-1. Raise collective full up, rotate (throttle) twist grip as required, loosen screw, and pivot A607-2 slotted cam (in throttle linkage, forward of vertical firewall) so V3-1 switch activates when throttle stop is approximately 0.027 inch from fuel control nylon stop. Tighten screw.
 - ii. **O-540:** Refer to Figure 37-1. Raise collective full up, rotate (throttle) twist grip as required, loosen screw, and pivot A607-2 slotted cam (in throttle linkage, forward of vertical firewall) so V3-1 switch activates when throttle stop is approximately 0.062 inch from corner of throttle body full-throttle stop. Tighten screw.
- b. Perform switch rigging check per step 1.

37-80 Carbon Monoxide Detector

The carbon monoxide (CO) detector, if installed, indicates elevated cabin CO levels. CO is an odorless, toxic gas present in engine exhaust which causes headaches, drowsiness, and possible loss of consciousness. CO levels may become elevated due to an exhaust leak or exhaust recirculation during prolonged hovering.

The CO detector system consists of a sensor above the pilot's heater outlet and a caution light. A system check (light flashes twice) is performed each time power is switched on. A sensor malfunction is indicated by a continuing flash every four seconds.

If the caution light illuminates, shut off heater and open nose and door vents as required to ventilate the cabin. If hovering, land or transition to forward flight. If symptoms of CO poisoning (headache, drowsiness, dizziness) accompany caution light, land immediately. Have exhaust system inspected before next flight.

Many chemicals can damage the CO sensor. Avoid use of solvents, detergents, or aerosol sprays near the sensor. Temporarily tape off openings in top and bottom of sensor housing when cleaning cabin interior.

37-90 Emergency Locator Transmitter (ELT)

The Emergency Locator Transmitter (ELT) installation consists of a transmitter with internal battery pack, an external antenna, and a remote switch/annunciator. The transmitter is mounted to the upper steel tube frame and is accessible through the aft, upper cowl door. The remote switch/annunciator is located left of the cyclic stick.

The ELT is operated by a switch on the transmitter and a remote switch in the cockpit. The transmitter switch has been secured in the AUTO or ARM position at installation and should always be in this position for flight. The remote switch/annunciator is a three position switch with indicator light. This switch should also be in the AUTO or ARMED (middle) position for flight. With both switches set to AUTO/ARM, the ELT will begin transmitting when subjected to a high "G" load. When the unit is transmitting, the red indicator light illuminates.

Moving the remote switch to ON activates the transmitter. Use the ON position if an emergency landing is imminent and time permits.

If the ELT is inadvertently activated, use the RESET position of the remote switch to stop transmission and reset the unit. The red indicator will extinguish when unit is reset.

NOTE

Earlier aircraft may have ELT installations without remote switch.

For more detailed instructions on ELT operation, maintenance, and required tests, refer to manufacturer's instructions supplied with the unit.

37-100 Low Rotor RPM Warning System

When the collective is raised 0.2 to 0.4 inch (measured at grip) above fully down, the low-rotor RPM warning unit must activate the low-rpm warning horn and low-rpm light at 97% to 96% rotor RPM; horn and light must turn off above 96% to 97% rotor RPM.

The low rotor RPM warning unit is located on the inside of the upper console, mounted on the left vertical panel. Adjustments are made by turning an exposed screw on warning unit, accessible by removing a black-plastic plug from a 3/8-inch diameter hole on the left vertical panel. The A569 warning unit's adjustment screw sensitivity is approximately 2 turns per 1% change. If warning unit cannot be adjusted to range stated above, it must be replaced.

Intentionally Blank

37-110 Troubleshooting

Following are some troubles and corrections. When investigating trouble, eliminate causes one by one, beginning with the most probable.

A. A569 Low Rotor RPM Warning Unit

Perform following tests prior to replacing A569 low rotor-rpm warning unit:

1. Verify:
 - a. Low RPM light bulb is functional.
 - b. Battery switch off.
 - c. Full-down collective.
 - d. Horn circuit breaker in.
2. Access and disconnect both horn and A569 low rotor-rpm warning unit from airframe electrical wiring.
3. Turn battery switch on and verify Horn Start circuit breaker remains in. If Horn Start circuit breaker pops then -70 wire is shorted to ground; repair as required. Turn battery switch off.
4. On the warning unit's airframe electrical connector, install a jumper between wires -70 & -75.
5. Turn battery switch on and verify Horn Start circuit breaker remains in. If Horn Start circuit breaker pops then a short-to-ground exists in -75 wire and/or collective-activated V3-1 switch; repair as required.
6. Fully raise collective and verify Horn Start circuit breaker remains in and Low RPM light illuminates. If Horn Start circuit breaker pops then a short-to-ground exists in -76 wire and/or -78 wire and/or collective-activated V3-1 switch; repair as required. If Low RPM light does not illuminate then collective-activated V3-1 switch is faulty or misadjusted and/or an open exists in -70, -75, or -76 wires.
7. Slowly raise and lower collective fully several times while simultaneously manipulating throttle. Verify Horn Start circuit breaker remains in and Low RPM light remains illuminated whenever collective is raised. If Horn Start circuit breaker pops then a short-to-ground condition is occurring in -70, -75, or -76 wires and/or collective-activated V3-1 switch due to collective movement. Check for pinched/rubbing wiring and repair as required.
8. Turn battery switch off. Connect horn to airframe wiring.
9. Turn battery switch on. Raise collective and verify horn activates and has consistent tone. If Horn Start circuit breaker pops then horn is faulty and/or -78 wire is shorted to ground; repair as required. If horn fails to activate then -79 wire is open or horn is faulty; repair as required. If tone is inconsistent then horn is faulty and/or poor connections exist; repair as required.

37-110 Troubleshooting (continued)**A. A569 Low Rotor RPM Warning Unit (continued)**

10. Check A999 master radio relay current draw:
 - a. Battery switch off and belt tension actuator fully disengaged.
 - b. Disconnect A569 low-rpm warning unit's connector and place an ammeter in series (positive lead on pin 10) between pins 10 and 11 on airframe side of connector.
 - c. Battery switch on, Horn Start and Clutch Start circuit breakers in, avionics off, rotor brake released, mixture at idle cut-off.
 - d. Select key switch to Start (Both on Raven IIs) position and crank engine. Note and record current draw at ammeter while cranking engine. Select key switch to Off position.
 - e. Disconnect 582 wire at tab on starter solenoid and isolate connector (do not let it ground). Select key switch to Start position. Note and record current draw at ammeter; for 14-volt systems current should be 94–156 milliamps and a buzzing sound should be heard from the starter vibrator (for 28-volt systems current should be 40–70 milliamps and starter vibrator should make no noise). Select key switch to Off position.
11. Check starter circuit:
 - a. Battery switch off and belt tension actuator fully disengaged.
 - b. Disconnect A569 low-rpm warning unit's connector and jump pins 10 and 11 on airframe side of connector.
 - c. Battery switch on, Horn Start and Clutch Start circuit breakers in, rotor brake released, mixture at idle cut-off.
 - d. Select key switch to Start position and crank engine. If engine does not crank there is a problem in the starter circuit. If engine cranks then there is a problem in either the A569 unit or the sense circuit.
12. Check A569 sense circuit:
 - a. Battery switch on.
 - b. Momentarily engage clutch and verify Clutch light illuminates then disengage clutch completely (switch to remain disengaged throughout this sequence).
 - c. Battery switch off.
 - d. Disconnect D602 time delay connector. Ground airframe-side plug's pin 1 thru a suitable voltage (post-light type) lamp.

CAUTION

Failure to ground pin 1 thru a suitable voltage lamp (such as direct grounding) may result in wiring damage.

37-110 Troubleshooting (continued)**A. A569 Low Rotor RPM Warning Unit (continued)**

12.
 - e. Verify less than 200 ohms (20 ohm nominal for 14-volt system; 70 ohm nominal for 28-volt system) to ground at pin 4 and at pin 5 on ship side of A569 connector.
 - f. Battery switch on.
 - g. With A569-5 unit connected to airframe harness, verify voltage does not exceed 0.5V from pin 4 to ground and from pin 5 to ground.
 - h. Battery switch on, Horn Start and Clutch Start circuit breakers 1n, rotor brake released, mixture at idle cut-off.
 - i. Select key switch to Start position and crank engine. Failure of engine to crank indicates problem in A569 unit.
13. Upon completion of preceding tests, a faulty A569 low rotor-rpm warning unit may be replaced and adjusted per § 37-100.

37-110 Troubleshooting (continued)

B. General

TROUBLE	PROBABLE CAUSE	CORRECTION
No electrical power	Battery terminals corroded Bad or no ground Tripped circuit breaker Low battery voltage Low or no alternator output Bad wire or terminal	Clean terminals Clean ground path Check circuit, if circuit checks ok, reset circuit breaker Check battery. Recharge if necessary. Check alternator belt tension, wiring, and alternator control unit Replace
Engine cranks slowly, but will not start	Low battery voltage Insufficient drive belt deflection Corroded or dirty battery or starter terminals Bad starter relay, wires or terminals	Service or replace battery Adjust actuator down-limit screw Clean terminals Replace defective parts
Engine cranks, but will not start	Key switch in off position (IO-540) Bad ignition switch Bad starting vibrator Incorrect retard timing	Place switch in BOTH position Replace switch Repair or replace vibrator Adjust retard magneto internal timing
Starter fails to operate	Rotor brake engaged Low battery charge Circuit breakers tripped Actuator not fully disengaged Loose connections Defective wiring Starter motor - burned winding or bad brushes Faulty A569 low-RPM warning unit	Release rotor brake Check and recharge if necessary Reset both HORN START and CLUTCH START circuit breakers Engage actuator momentarily, then fully disengage Check all wiring (refer to wiring diagram) Check all wiring (refer to wiring diagram) Repair or replace starter Check unit per Part !

37-110 Troubleshooting (continued)

B. General (continued)

TROUBLE	PROBABLE CAUSE	CORRECTION
Discharged battery	Battery worn out	Replace battery.
	Charging rate not set correctly	Check alternator control unit output. Replace if below 13.4 volts.
	Standing too long	Remove and recharge battery if left in unused helicopter for four or more weeks.
Starter — Low cranking speed	Same electrical causes as listed under "starter fails to operate"	Same remedies listed for those troubles.
Battery life is short	Impurities in electrolyte	Replace battery.
	Low charging rate	Check ACU output. If below 13.4 volts replace the unit.
Electrolyte runs out of battery	Too much water added to battery.	Drain and keep battery at proper fluid level and specific gravity.
	Charging rate too high.	Check the ACU output voltage. Replace if necessary.
Excessive electrolyte inside container	Spillage from overfilling	Use care in adding water.
	Vent lines leaking or clogged	Repair or clean.
	Charging rate too high	Check the ACU output voltage. Replace if necessary.
Battery consumes excessive water	Charging rate too high (if in all cells)	Check the ACU output voltage. Replace if necessary.
Alternator fails to supply charging current with engine operating	ACU failure Open field circuit wiring	Check the ACU output voltage. Replace if necessary. Repair or replace wiring to field circuit.

37-110 Troubleshooting (continued)

B. General (continued)

TROUBLE	PROBABLE CAUSE	CORRECTION
Starter kicks back while cranking; may cause broken starter or starter ring gear	Retard breaker contact in engine left magneto pushed out or no connection between lead and magneto contact	Measure retard breaker lead connection. Must be 0.609 in. ± 0.10 in. There must be a small amount of springback when the connector is placed into magneto.
	Incorrect ignition vibrator wiring	Trace ignition vibrator wiring from ignition switch to magneto. Correct as required.
	Bad ignition switch	Replace ignition switch
	Bad ignition vibrator	Replace vibrator
	Incorrect internal magneto retard breaker timing. Engine left magneto	Correct as required. Consult TCM Aircraft Products literature.
	Open circuit in ignition vibrator wiring circuit	Repair or replace wiring for ignition vibrator.

37-110 Troubleshooting (continued)

C. Clutch Actuator Electrical Troubleshooting

TROUBLE	CLUTCH LIGHT		PROBABLE CAUSE
	ON	OFF	
Disengaged actuator will not engage	X		Motor assembly seized
	X		Motor fuse blown (3-amp)
	X		Open circuit in motor wiring
	X		Overtravel switch assembly tripped or broken
		X	No voltage at circuit breaker
		X	Circuit breaker tripped
		X	Down limit switch stuck (normally closed)
		X	-113 wire not grounded
Engaged actuator will not disengage	X		Motor assembly seized
	X		Motor fuse blown (3-amp)
	X		Open circuit in motor wiring
	X		D602-1 time delay assembly internal diode open
		X	No voltage at circuit breaker
		X	Circuit breaker tripped
		X	Up limit switch stuck (normally closed)
		X	-113 wire not grounded
Clutch light flickers in flight			Actuator leaf spring improperly adjusted.
			C190 drive belts not matched properly.
			Open circuit in motor wiring.
			C184-1 or C007-3 bearing running rough.
Clutch light comes on for 1–6 seconds in flight			Normal operation of actuator as it retensions drive belts
Clutch light comes on for over 6 seconds in flight			Drive belts stretched beyond limit of actuator overtravel switch. Belts must be replaced.
			Actuator overtravel switch activated by outside force
Clutch light comes on for over 10 seconds in flight			Check sheaves and belts for excessive wear.
			Check column springs for operation.
			Verify fanwheel balance.
			Check or change out time delay.
			Remove actuator and send to RHC for evaluation.

37-110 Troubleshooting (continued)

D. Electrically Powered Instruments Accuracy Check

Using Vibrex 2000 balancing equipment (or similar) capable of displaying ± 1 rpm resolution and calibrated within one year, verify tachometer accuracy per following tables. Connect equipment in accordance with §§ 10.221 and 6.240 (use photocell instead of Strobex per Figure 6-4A). Operate aircraft at noted tachometer indications and verify engine and rotor rpms as specified. Tachometer needles are 1% wide.

C792-x Dual Tachometer

Tachometer indication	Engine RPM	Rotor RPM
96%	2556-2561	383-384
100%	2662-2667	399-400
102%	2715-2721	407-408

The rotor tachometer may be adjusted per § 13-23. No other adjustments are permitted. If tachometer does not meet accuracy tolerance then it must be replaced or returned to RHC for repair.

A058-10 Carb. Air Temp. Probe

0 degrees	=	89.68/91.08 ohms
15 degrees	=	95.67/98.07 ohms
16 degrees	=	96.10/98.50 ohms
17 degrees	=	96.54/98.94 ohms
18 degrees	=	96.97/99.37 ohms
19 degrees	=	97.40/99.80 ohms
20 degrees	=	97.83/100.23 ohms
21 degrees	=	98.27/100.67 ohms
22 degrees	=	98.70/101.10 ohms
23 degrees	=	99.13/101.53 ohms
24 degrees	=	99.56/101.96 ohms
25 degrees	=	100.00/102.40 ohms

R44 C604-2 Carb. Air Temp. Gage at 13.7 Vdc;

R44 C604-8 Carb. Air Temp. Gage at 28.2 Vdc

77.40 ohms	=	-30 ± 2	degrees C
81.73 ohms	=	-20 ± 1.75	degrees C
86.05 ohms	=	-10 ± 1.5	degrees C
90.38 ohms	=	0 ± 1	degrees C
94.71 ohms	=	10 ± 1.5	degrees C
99.03 ohms	=	20 ± 1.75	degrees C
103.36 ohms	=	30 ± 2	degrees C

Example: Replacing the carburetor air temperature probe with a ¼ to 1-watt 100-ohm resistor should result in a indication of approximately 21 degrees C (measure exact resistor value & refer to above). A probe dipped in a Styrofoam cup full of crushed ice and water should indicate 90.38 ohms resistance per above table. Probe installation torque is 36 to 48 inch-pounds; over-torquing probe will result in damage.

37-110 Troubleshooting (continued)

D. Electrically Powered Instruments Accuracy Check (continued)

Following instrument cluster gages are calibrated at 20 to 25 degree angle from horizontal.

Fuel level senders should have 90 ± 2 ohms resistance when fully up (full fuel) and 0 to 0.5 ohm when fully down (no fuel). Perform fuel sender calibration per § 12.411 whenever sender is replaced, or if factory-set fuel gage potentiometers have been disturbed. On backside of each fuel gage are "Null" and "Gain" potentiometer screws, covered with aluminum tape pressed against the screw heads to prevent rotation. "Null" potentiometer is adjusted so gage indicates empty at 0.7 ohm sender circuit resistance; "Gain" is adjusted so gage indicates half at 42 ohms sender circuit resistance. Calibration values are:

Fuel Quantity Gages

6246-00473 (14V) & 6246-00716 (28V)

0.70 ohm =	E (empty) -1, +0	pointer width
21.20 ohms =	1/4 full ± 1	pointer width
42.00 ohms =	1/2 full ± 1	pointer width
67.50 ohms =	3/4 full ± 1	pointer width
90.00 ohms =	F (full) ± 1	pointer width

Ammeter

6246-00468 (14V & 28V)

-104 mV =	-70 amps ± 1	pointer width
-52 mV =	-35 amps ± 1	pointer width
0 mV =	0 amps $\pm \frac{1}{4}$	pointer width
+52 mV =	+35 amps ± 1	pointer width
+104 mV =	+70 amps ± 1	pointer width

CHT Probe

3080-38 (14V & 28V)

200 degrees F =	745 ohms
475 degrees F =	38 ohms
500 degrees F =	32 ohms

CHT Gages

6246-00088 (14V) & 6246-00718 (28V)

745 ohms =	200 degrees F ± 1	pointer width
110 ohms =	350 degrees F ± 1	pointer width
34 ohms =	500 degrees F $\pm \frac{1}{2}$	pointer width

Oil Pressure Sending Unit

B308-1 (14V & 28V)

0 psi =	5-13 ohms
29 psi =	48-57 ohms
58 psi =	84-94 ohms
87 psi =	119 131 ohms
115 psi =	145-161 ohms

115-psi redline Oil Pressure Gages

6246-00647 (14V) & 6246-00715 (28V)

9 ohms =	0 psi ± 1	pointer width
46 ohms =	25 psi ± 1	pointer width
84 ohms =	55 psi ± 1	pointer width
131 ohms =	95 psi ± 1	pointer width
152 ohms =	115 psi ± 1	pointer width

37-110 Troubleshooting (continued)**D. Electrically Powered Instruments Accuracy Check (continued)****Oil Temperature Sender**
A760-1 (14V)

100 degrees F = 497 ohms
150 degrees F = 179 ohms
200 degrees F = 72 ohms
250 degrees F = 34 ohms

Oil Temperature Gage
6246-00090 (14V) 6246-00717 (28V)

903.5 ohms = 75 degrees F \pm 1 pointer width
100 ohms = 180 degrees F \pm 1 pointer width
36 ohms = 245 degrees F \pm 1 pointer width

37-120 Electrical Load Analysis

To calculate the total electrical load for a specific helicopter, identify all items of equipment installed on the helicopter from the table below and sum the corresponding continuous and intermittent loads.

Maximum continuous alternator load is given in the table below:

System Voltage	Alternator Rating	Maximum Continuous Load
14V	70 amp	50 amps
28V	70 amp	64 amps
28V	130 amp	85 amps

Intermittent loads are provided for reference.

Alternately, the electrical load may be measured directly at the battery output terminal with the alternator switched off and all other equipment turned on. The measured load may be scaled by the ratio of battery voltage to nominal system voltage to obtain a value that is compared with the alternator load limit.

WARNING

Field (non-factory) installation of electronic equipment can be hazardous. Due to the compactness of the console and tunnel containing the controls and wire bundles, installation of any additional wires can interfere with flight controls. Electronic tachometers, warning systems, and navigation equipment essential to flight are sensitive to interference from other electrical devices. The reliability and accuracy of the tachometers is essential for safe operation of the helicopter, and installation of an electrical device not tested and approved by RHC may result in a hazardous condition.

A. 14-Volt System

EQUIPMENT	QTY	CONTINUOUS AMPS EACH	INTERMITTENT AMPS EACH	CONTINUOUS TOTAL	INTERMITTENT TOTAL
MAIN BUS					
ESSEX BATTERY RELAY	1	0.75	0.75	0.75	0.75
KISSLING BATTERY RELAY	1	0.35	0.35	0.35	0.35
ALTERNATOR FIELD	1	2.40	2.40	2.40	2.40
AVIONICS RELAY	1	0.13	0.13	0.13	0.13
ENGINE GAGE CLUSTER	1	0.60	0.60	0.60	0.60
HOURLY METER	1	0.03	0.03	0.03	0.03
CARB AIR TEMP	1	0.13	0.13	0.13	0.13
AMMETER	1	0.50	0.50	0.50	0.50
DIGITAL OAT GAGE	1	0.15	0.15	0.15	0.15
MAP LIGHT	1	0.58	0.58	0.58	0.58

37-120 Electrical Load Analysis (continued)

A. 14-Volt System (continued)

EQUIPMENT	QTY	CONTINUOUS AMPS EACH	INTERMITTENT AMPS EACH	CONTINUOUS TOTAL	INTERMITTENT TOTAL
MAIN BUS (continued)					
WARNING LIGHTS	10	0.00	0.08	0.00	0.80
FULL THROTTLE CAUTION LIGHT	1	0.00	0.08	0.00	0.08
LOW RPM HORN	1	0.00	0.25	0.00	0.25
RPM GOVERNOR MOTOR	1	0.00	1.50	0.00	1.50
BELT TENSION ACTUATOR	1	0.00	3.50	0.00	3.50
TRIM MOTORS	2	0.00	1.15	0.00	2.30
HYDRAULIC SHUTOFF SOLENOID	1	0.00	1.54	0.00	1.54
AUX POWER PLUGS (MAX)	1	10.00	10.00	10.00	10.00
HEATED PITOT	1	8.00	8.00	8.00	8.00

EQUIPMENT	QTY	CONTINUOUS AMPS EACH	INTERMITTENT AMPS EACH	CONTINUOUS TOTAL	INTERMITTENT TOTAL
TACH BUS					
DUAL TACHOMETER (E)	1	0.10	0.10	0.10	0.10
DUAL TACHOMETER (R)	1	0.10	0.10	0.10	0.10

EQUIPMENT	QTY	CONTINUOUS AMPS EACH	INTERMITTENT AMPS EACH	CONTINUOUS TOTAL	INTERMITTENT TOTAL
LIGHTS BUS					
POSITION LIGHTS (L, R, & AFT, INCANDESCENT)	3	2.20	2.20	6.60	6.60
POSITION LIGHTS (L & R, LED)	2	0.25	0.25	0.50	0.50
POSITION LIGHT (AFT, LED)	1	0.30	0.30	0.30	0.30
MAST MOUNTED POS LIGHT RELAY	1	0.20	0.20	0.20	0.20
MAST MOUNTED POSITION LIGHTS	2	2.20	2.20	4.40	4.40
MAST MOUNTED POSITION LIGHTS (LED)	2	0.25	0.25	0.50	0.50
OVERHEAD PANEL LIGHT	1	1.00	1.00	1.00	1.00
POST LIGHTS	7	0.08	0.08	0.56	0.56
INSTRUMENT LIGHTS	4	0.20	0.20	0.80	0.80
LANDING LIGHT RELAY	1	0.20	0.20	0.20	0.20
LANDING LIGHTS (INCANDESCENT)	2	7.70	7.70	15.40	15.40
LANDING LIGHTS (HID)	2	2.90	9.52	5.80	19.04
ANTI-COLLISION LIGHT & POWER SUPPLY	1	3.20	3.20	3.20	3.20
ANTI-COLLISION LIGHT (FORWARD)	1	3.40	3.40	3.40	3.40

37-120 Electrical Load Analysis (continued)

A. 14-Volt System (continued)

EQUIPMENT	QTY	CONTINUOUS AMPS EACH	INTERMITTENT AMPS EACH	CONTINUOUS TOTAL	INTERMITTENT TOTAL
LIGHTS BUS (continued)					
ANTI-COLLISION LIGHT (LED)	1	0.90	4.00	0.90	4.00
ANTI-COLLISION LIGHT (LED, FORWARD)	1	0.90	4.00	0.90	4.00

EQUIPMENT	QTY	CONTINUOUS AMPS EACH	INTERMITTENT AMPS EACH	CONTINUOUS TOTAL	INTERMITTENT TOTAL
AVIONICS					
KY197A COM	1	0.80	6.00	0.80	6.00
GTR225B COM	1	0.59	5.90	0.59	5.90
KX155 NAV/COM	1	0.40	6.00	0.40	6.00
KX165 NAV/COM	1	0.70	8.50	0.70	8.50
GNC420 COM/GPS	1	2.44	8.40	2.44	8.40
GNS430 COM/NAV/GPS	1	2.44	8.40	2.44	8.40
GNS530 COM/NAV/GPS	1	2.84	8.80	2.84	8.80
GTN625/635/650 COM/NAV/GPS	1	2.65	6.97	2.65	6.97
GTN725/750 COM/NAV/GPS	1	3.45	10.22	3.45	10.22
KR87 ADF	1	1.24	1.24	1.24	1.24
KN63 DME	1	1.21	1.21	1.21	1.21
GARMIN RADIO NAVIGATION INDICATOR	1	0.41	0.41	0.41	0.41
KING RADIO NAVIGATION INDICATOR	1	0.08	0.08	0.08	0.08
MARKER BEACON	1	0.50	0.50	0.50	0.50
GARMIN TRANSPONDER	1	1.10	3.10	1.10	3.10
GDL88 ADS-B IN	1	1.28	1.28	1.28	1.28
KCS55A HSI	1	3.23	3.23	3.23	3.23
RADAR ALTIMETER	1	1.45	1.45	1.45	1.45
AA12S AUDIO CONTROL (SINGLE, STEREO)	1	1.00	1.00	1.00	1.00
AMS42 DUAL AUDIO CONTROL	1	0.57	0.57	0.57	0.57
AIR COMM SINGLE AUDIO CONTROL	1	1.00	1.00	1.00	1.00
AIR COMM DUAL AUDIO CONTROL	1	3.00	3.00	3.00	3.00
GMA 350H AUDIO CONTROL	1	0.80	1.50	0.80	1.50
ASPEN EFD 500H EFD	1	1.60	1.60	1.60	1.60
ASPEN EFD 1000H PFD	1	4.80	4.80	4.80	4.80
ATTITUDE HORIZON (MECHANICAL)	1	0.54	1.40	0.54	1.40
ATTITUDE HORIZON (LCD)	1	0.20	0.20	0.20	0.20

37-120 Electrical Load Analysis (continued)

A. 14-Volt System (continued)

EQUIPMENT	QTY	CONTINUOUS AMPS EACH	INTERMITTENT AMPS EACH	CONTINUOUS TOTAL	INTERMITTENT TOTAL
AVIONICS (continued)					
DIRECTIONAL GYRO	1	0.44	1.40	0.44	1.40
TURN COORDINATOR	1	0.70	0.70	0.70	0.70
KG102A GYRO	1	3.00	3.00	3.00	3.00
HELISAS	1	4.29	4.29	4.29	4.29
COOLING BLOWER	1	0.30	0.30	0.30	0.30

EQUIPMENT	QTY	CONTINUOUS AMPS EACH	INTERMITTENT AMPS EACH	CONTINUOUS TOTAL	INTERMITTENT TOTAL
MARINE AVIONICS					
ICOM IC-M412 MARINE TRANSCIEVER	1	1.50	5.50	1.50	5.50
VERTEX VX-2200 FM TRANSCIEVER	1	2.50	11.00	2.50	11.00
KENWOOD TK-7160 OR TK8160 FM TRANSCIEVER	1	1.00	8.00	1.00	8.00
KENWOOD TK-7180 OR TK8180 FM TRANSCIEVER	1	1.00	9.00	1.00	9.00
YAESU FT-8800R FM TRANSCIEVER	1	0.50	8.00	0.50	8.00
GPSMAP 169 MARINE GPS	1	0.29	0.29	0.29	0.29

EQUIPMENT	QTY	CONTINUOUS AMPS EACH	INTERMITTENT AMPS EACH	CONTINUOUS TOTAL	INTERMITTENT TOTAL
OTHER EQUIPMENT					
STARTER RELAY	1	0.00	15.00	0.00	15.00
STARTING VIBRATOR	1	0.00	2.50	0.00	2.50
STARTER MOTOR	1	0.00	200.00	0.00	200.00
CLOCK, STANDARD	1	0.02	0.02	0.02	0.02
CLOCK, DIGITAL	1	0.00	0.00	0.00	0.00

37-120 Electrical Load Analysis (continued)

B. 28-Volt System

EQUIPMENT	QTY	CONTINUOUS AMPS EACH	INTERMITTENT AMPS EACH	CONTINUOUS TOTAL	INTERMITTENT TOTAL
MAIN BUS					
ALTERNATOR FIELD (70 AMP)	1	2.40	2.40	2.40	2.40
ALTERNATOR FIELD (130 AMP)	1	4.00	4.00	4.00	4.00
AMMETER	1	0.50	0.50	0.50	0.50
EATON BATTERY RELAY	1	0.50	0.50	0.50	0.50
KISSLING BATTERY RELAY	1	0.25	0.25	0.25	0.25
AVIONICS RELAY	1	0.10	0.10	0.10	0.10
CARB AIR TEMP	1	0.07	0.07	0.07	0.07
MAP LIGHT	1	0.30	0.30	0.30	0.30
MAP LIGHT (LED)	1	0.02	0.02	0.02	0.02
DIGITAL OAT GAGE	1	0.15	0.15	0.15	0.15
ENGINE GAGE CLUSTER	1	0.29	0.29	0.29	0.29
HOURLMETER	1	0.02	0.02	0.02	0.02
HYDRAULIC SHUTOFF SOLENOID	1	0.80	0.80	0.80	0.80
LOW RPM HORN	1	0.00	0.25	0.00	0.25
LOW RPM WRG. UNIT	1	0.00	0.16	0.00	0.16
WARNING LIGHTS	12	0.00	0.04	0.00	0.48
RPM GOVERNOR MOTOR & CONVERTER	1	0.60	0.60	0.60	0.60
BELT TENSION ACTUATOR	1	0.00	1.40	0.00	1.40
TRIM MOTORS & CONVERTER	2	0.55	1.00	1.10	2.00
ELECTRIC FUEL PUMP	1	0.00	3.00	0.00	3.00
FUEL PRESS WARNING LIGHT	1	0.00	0.04	0.00	0.04
FUEL PUMP RELAY	1	0.00	0.09	0.00	0.09
FULL THROTTLE CAUTION LIGHT	1	0.00	0.04	0.00	0.04
AUX POWER PLUGS (MAX)	1	10.00	10.00	10.00	10.00
HEATED PITOT	1	4.00	4.00	4.00	4.00

EQUIPMENT	QTY	CONTINUOUS AMPS EACH	INTERMITTENT AMPS EACH	CONTINUOUS TOTAL	INTERMITTENT TOTAL
TACH BUS					
DUAL TACHOMETER (E)	1	0.03	0.03	0.03	0.03
DUAL TACHOMETER (R)	1	0.04	0.04	0.04	0.04

37-120 Electrical Load Analysis (continued)

B. 28-Volt System (continued)

EQUIPMENT	QTY	CONTINUOUS AMPS EACH	INTERMITTENT AMPS EACH	CONTINUOUS TOTAL	INTERMITTENT TOTAL
LIGHTS BUS					
INSTRUMENT LIGHTS	8	0.10	0.10	0.80	0.80
LANDING LIGHT RELAY	1	0.08	0.08	0.08	0.08
LANDING LIGHTS (INCANDESCENT)	2	3.57	3.57	7.14	7.14
LANDING LIGHTS (HID)	2	1.60	5.25	3.20	10.50
MAST MOUNTED POS LIGHT RELAY	1	0.20	0.20	0.20	0.20
OVERHEAD PANEL LIGHT	1	0.50	0.50	0.50	0.50
POSITION LIGHTS (INCANDESCENT)	3	1.10	1.10	3.30	3.30
POSITION LIGHTS (L & R, LED)	2	0.25	0.25	0.50	0.50
POSITION LIGHT (AFT, LED)	1	0.30	0.30	0.30	0.30
POSITION LIGHTS (MAST MOUNTED, INCANDESCENT)	2	2.20	2.20	4.40	4.40
POSITION LIGHT (MAST MOUNTED, LED)	2	0.25	0.25	0.50	0.50
POST LIGHTS	7	0.04	0.04	0.28	0.28
ANTI-COLLISION LIGHT & POWER SUPPLY	1	1.70	1.70	1.70	1.70
ANTI-COLLISION LIGHT (FORWARD)	1	1.80	1.80	1.80	1.80
ANTI-COLLISION LIGHT (LED)	1	0.67	3.00	0.67	3.00
ANTI-COLLISION LIGHT (LED, FORWARD)	1	0.67	3.00	0.67	3.00

EQUIPMENT	QTY	CONTINUOUS AMPS EACH	INTERMITTENT AMPS EACH	CONTINUOUS TOTAL	INTERMITTENT TOTAL
AVIONICS					
KY196A COM	1	1.00	5.00	1.00	5.00
GTR225B COM	1	0.28	2.60	0.28	2.60
GNC420 COM/GPS	1	1.22	4.20	1.22	4.20
GNS430 COM/NAV/GPS	1	1.22	4.20	1.22	4.20
GNS530 COM/NAV/GPS	1	1.42	4.40	1.42	4.40
GTN625/635/650 COM/NAV/GPS	1	1.31	4.41	1.31	4.41
GTN725/750 COM/NAV/GPS	1	1.71	4.71	1.71	4.71
KTR909 UHF TRANSCIEVER	1	0.60	8.00	0.60	8.00
KX155 NAV/COM	1	0.40	6.00	0.40	6.00
KX165 NAV/COM	1	0.70	8.50	0.70	8.50
KR87 ADF	1	0.62	0.62	0.62	0.62
KN63 DME	1	0.61	0.61	0.61	0.61
GARMIN RADIO NAVIGATION INDICATOR	1	0.10	0.10	0.10	0.10

37-120 Electrical Load Analysis (continued)

B. 28-Volt System (continued)

EQUIPMENT	QTY	CONTINUOUS AMPS EACH	INTERMITTENT AMPS EACH	CONTINUOUS TOTAL	INTERMITTENT TOTAL
AVIONICS (continued)					
KING RADIO NAVIGATION INDICATOR	1	0.06	0.06	0.06	0.06
MARKER BEACON	1	0.50	0.50	0.50	0.50
GARMIN TRANSPONDER	1	0.85	1.60	0.85	1.60
GDL88 ADS-B IN	1	0.64	0.64	0.64	0.64
KCS55A HSI	1	1.73	1.73	1.73	1.73
RADAR ALTIMETER	1	0.73	0.73	0.73	0.73
GMA 350H AUDIO CONTROL	1	0.40	1.00	0.40	1.00
AMS42 DUAL AUDIO CONTROL	1	0.41	0.41	0.41	0.41
AA12S AUDIO CONTROL (SINGLE, STEREO)	1	0.80	0.80	0.80	0.80
AIR COMM SINGLE AUDIO CONTROL	1	0.50	0.50	0.50	0.50
AIR COMM DUAL AUDIO CONTROL	1	1.50	1.50	1.50	1.50
ASPEN 500H EFD	1	0.80	0.80	0.80	0.80
ASPEN 1000H PFD	1	2.40	2.40	2.40	2.40
ATTITUDE HORIZON W/INCL (MECHANICAL)	1	0.27	0.70	0.27	0.70
ATTITUDE HORIZON (LCD)	1	0.18	0.18	0.18	0.18
BLIND ENCODER	1	0.15	0.15	0.15	0.15
DIRECTIONAL GYRO	1	0.25	0.60	0.25	0.60
TURN COORDINATOR	1	0.35	0.35	0.35	0.35
HORIZON REF IND.	1	1.80	1.80	1.80	1.80
HELISAS	1	2.14	2.14	2.14	2.14
COOLING BLOWER	1	0.20	0.20	0.20	0.20

EQUIPMENT	QTY	CONTINUOUS AMPS EACH	INTERMITTENT AMPS EACH	CONTINUOUS TOTAL	INTERMITTENT TOTAL
AIR CONDITIONING					
COMPRESSOR	1	1.22	1.22	1.22	1.22
DOME LIGHT LED	1	0.02	0.02	0.02	0.02
EVAPORATOR BLOWER	1	8.25	8.25	8.25	8.25

37-120 Electrical Load Analysis (continued)

B. 28-Volt System (continued)

EQUIPMENT	QTY	CONTINUOUS AMPS EACH	INTERMITTENT AMPS EACH	CONTINUOUS TOTAL	INTERMITTENT TOTAL
MARINE AVIONICS					
GPSMAP 162 MARINE GPS	1	0.14	0.14	0.14	0.14
ICOM IC-M412 MARINE TRANSCEIVER	1	1.50	5.50	1.50	5.50
VERTEX VX-2200 FM TRANSCEIVER	1	0.70	7.00	0.70	7.00
KENWOOD TK-7160 OR TK8160 FM TRANSCEIVER	1	1.00	8.00	1.00	8.00
KENWOOD TK-7180 OR TK8180 FM TRANSCEIVER	1	1.00	9.00	1.00	9.00
YAESU FT-8800R FM TRANSCEIVER	1	0.50	8.00	0.50	8.00
ROSS VHF FM TRANSCEIVER	1	0.60	6.00	0.60	6.00

EQUIPMENT	QTY	CONTINUOUS AMPS EACH	INTERMITTENT AMPS EACH	CONTINUOUS TOTAL	INTERMITTENT TOTAL
OTHER EQUIPMENT					
STARTER MOTOR	1	0.00	200.00	0.00	200.00
STARTER ON LIGHT	1	0.00	0.04	0.00	0.04
STARTER RELAY	1	0.00	7.00	0.00	7.00
TCM STARTING VIBRATOR	1	0.00	2.50	0.00	2.50
UNISON STARTING VIBRATOR	1	0.00	5.00	0.00	5.00
CLOCK, STANDARD	1	0.02	0.02	0.02	0.02
CLOCK, DIGITAL	1	0.00	0.00	0.00	0.00

EQUIPMENT	QTY	CONTINUOUS AMPS EACH	INTERMITTENT AMPS EACH	CONTINUOUS TOTAL	INTERMITTENT TOTAL
POLICE EQUIPMENT (28V BUS)					
POLICE EQUIPMENT RELAY	1	0.43	0.43	0.43	0.43
DIGITAL VCR	1	0.28	0.28	0.28	0.28
ETS	1	0.53	1.50	0.53	1.50
NAT FM CONTROL HEAD	1	1.00	1.00	1.00	1.00
NAT NTX138-000 FM RADIO	1	0.70	2.00	0.70	2.00
TECHNISONIC TFM-500 FM TRANSCEIVER	1	1.00	3.20	1.00	3.20
INFRARED CAMERA SYSTEM	1	7.00	12.00	7.00	12.00
INTERIOR LIGHT	1	0.22	0.22	0.22	0.22

37-120 Electrical Load Analysis (continued)

B. 28-Volt System (continued)

EQUIPMENT	QTY	CONTINUOUS AMPS EACH	INTERMITTENT AMPS EACH	CONTINUOUS TOTAL	INTERMITTENT TOTAL
POLICE EQUIPMENT (28V BUS; continued)					
MICROWAVE SYSTEM	1	3.10	3.10	3.10	3.10
MONITOR	1	0.43	0.43	0.43	0.43
PA/SIREN	1	4.00	4.00	4.00	4.00
SEARCHLIGHT	1	27.00	27.00	27.00	27.00
SLAVE SYSTEM	1	0.15	0.49	0.15	0.49

EQUIPMENT	QTY	CONTINUOUS AMPS EACH	INTERMITTENT AMPS EACH	CONTINUOUS TOTAL	INTERMITTENT TOTAL
POLICE EQUIPMENT (14V BUS)					
ROSEN FLAT SCREEN MONITOR @ 13.75V	1	3.70	4.20		
ROSEN FLAT SCREEN MONITOR	1	2.31	2.63	2.31	2.63
BENDIX/KING FM RADIO @ 13.75V	1	1.00	1.50		
BENDIX/KING FM RADIO	1	0.63	0.94	0.63	0.94
LOJACK @ 13.75V	1	0.75	0.75		
LOJACK	1	0.47	0.47	0.47	0.47
PANASONIC VHS RECORDER @ 13.75V	1	1.20	1.20		
PANASONIC VHS RECORDER	1	0.75	0.75	0.75	0.75

EQUIPMENT	QTY	CONTINUOUS AMPS EACH	INTERMITTENT AMPS EACH	CONTINUOUS TOTAL	INTERMITTENT TOTAL
ENG EQUIPMENT (28V BUS)					
5" TRANSVIDEO MONITOR	3	0.28	0.59	0.84	1.77
6" SONY LCD MONITOR	1	0.43	0.43	0.43	0.43
AUDIO COOLING FAN	1	0.22	0.22	0.22	0.22
GENEVA AUDIO SYSTEM	1	1.92	1.92	1.92	1.92
AUDIO SYSTEM COOLING FAN	1	0.18	0.18	0.18	0.18
FLIR CAMERA SYSTEM	1	6.00	8.00	6.00	8.00
AFT COMPARTMENT COOLING FAN	1	0.20	0.20	0.20	0.20
DIRECTIONAL M/WAVE ANTENNA	1	0.70	0.70	0.70	0.70
DIRECTIONAL MICROWAVE SYSTEM	1	0.50	1.50	0.50	1.50
HD CAMERA SYSTEM	1	3.00	3.80	3.00	3.80

37-120 Electrical Load Analysis (continued)

B. 28-Volt System (continued)

EQUIPMENT	QTY	CONTINUOUS AMPS EACH	INTERMITTENT AMPS EACH	CONTINUOUS TOTAL	INTERMITTENT TOTAL
ENG EQUIPMENT (28V BUS; continued)					
HD MICRO CAMERA SYSTEM	2	0.86	0.86	1.72	1.72
MICROWAVE POWER AMP	1	8.60	8.60	8.60	8.60
MICROWAVE RECEIVER	1	0.70	0.70	0.70	0.70
MICROWAVE TRANSMITTER	1	1.35	1.35	1.35	1.35
MICROWAVE ANTENNA ACTUATOR MOTOR	1	0.00	0.75	0.00	0.75
MICROWAVE TRANSMITTER	1	3.10	3.10	3.10	3.10
NEWS EQUIP RELAY	1	0.43	0.43	0.43	0.43
OMNI MICROWAVE ANTENNA MOTOR	1	0.00	0.75	0.00	0.75
POST LIGHT	3	0.04	0.04	0.12	0.12
INTERIOR LIGHT (FORWARD)	1	0.22	0.22	0.22	0.22
INTERIOR LIGHT (REAR)	1	0.22	0.22	0.22	0.22
RADIO DESIGN LABS VIDEO SWITCH	1	0.00	0.03	0.00	0.03
VIDEO TITLER	1	0.07	0.07	0.07	0.07

EQUIPMENT	QTY	CONTINUOUS AMPS EACH	INTERMITTENT AMPS EACH	CONTINUOUS TOTAL	INTERMITTENT TOTAL
ENG EQUIPMENT (14V BUS)					
4" TELE LCD MONITOR @ 13.75V	3	0.50	0.50		
4" TELE LCD MONITOR	3	0.31	0.31	0.94	0.94
6" TRANSVIDEO REAR SEAT MONITOR @ 13.75V	1	1.50	1.50		
6" TRANSVIDEO REAR SEAT MONITOR	1	0.94	0.94	0.94	0.94
6.5" TRANSVIDEO MONITOR	3	0.30	0.30	0.90	0.90
9" ASTRO MONITOR @ 13.75V	1	1.67	1.67		
9" ASTRO MONITOR	1	1.04	1.04	1.04	1.04
AFT TALENT LIGHT @ 13.75V	1	1.00	1.00		
AFT TALENT LIGHT	1	0.63	0.63	0.63	0.63
AVIONICS INNOVATIONS AM/FM RECEIVER/CD @ 13.75V	2	0.38	0.70		
AVIONICS INNOVATIONS AM/FM RECEIVER/CD	2	0.23	0.44	0.47	0.88
AVIONICS INNOVATIONS AM/FM RECEIVERS @ 13.75V	2	0.65	0.65		

37-120 Electrical Load Analysis (continued)

B. 28-Volt System (continued)

EQUIPMENT	QTY	CONTINUOUS AMPS EACH	INTERMITTENT AMPS EACH	CONTINUOUS TOTAL	INTERMITTENT TOTAL
ENG EQUIPMENT (14V BUS; continued)					
AVIONICS INNOVATIONS AM/FM RECEIVERS	2	0.41	0.41	0.81	0.81
DOWN CONVERTER @ 13.75V	1	0.54	0.54		
DOWN CONVERTER	1	0.34	0.34	0.34	0.34
KENWOOD FM RADIO & GENEVA INTERFACE @ 13.75V	2	1.16	8.16		
KENWOOD FM RADIO & GENEVA INTERFACE	2	0.73	5.10	1.45	10.20
KENWOOD FM TRASCIEVER @ 13.75V	2	0.40	9.00		
KENWOOD FM TRASCIEVER	2	0.25	5.63	0.50	11.25
FWD TALENT LIGHT @ 13.75V	1	1.00	1.00		
FWD TALENT LIGHT	1	0.63	0.63	0.63	0.63
LED VU METER @ 13.75V	1	0.20	0.20		
LED VU METER	1	0.13	0.13	0.13	0.13
SD MICRO CAMERAS @ 13.75V	3	0.41	0.41		
SD MICRO CAMERAS	3	0.26	0.26	0.77	0.77
UNIDEN SCANNER @ 13.75V	1	0.38	0.70		
UNIDEN SCANNER	1	0.23	0.44	0.23	0.44
SD MICRO CAMERA @ 13.75V	2	0.41	10.22		
SD MICRO CAMERA	2	0.26	6.39	0.51	12.78
SVHS VIDEO TAPE RECORDER @ 13.75V	1	1.50	1.50		
SVHS VIDEO TAPE RECORDER	1	0.94	0.94	0.94	0.94
SYNC AND OUTPUT AMPS @ 13.75V	2	0.10	0.10		
SYNC AND OUTPUT AMPS	2	0.06	0.06	0.13	0.13
SYNC GENERATOR @ 13.75V	1	0.25	0.25		
SYNC GENERATOR	1	0.16	0.16	0.16	0.16
TALENT LIGHT (W/SD) @ 13.75V	1	1.43	1.43		
TALENT LIGHT (W/SD)	1	0.89	0.89	0.89	0.89
TALENT LIGHT (W/HD) @ 13.75V	2	0.11	0.11		
TALENT LIGHT (W/HD)	2	0.07	0.07	0.14	0.14
TUNER DISTRIBUTION AMP @ 13.75V	1	0.02	0.02		
TUNER DISTRIBUTION AMP	1	0.02	0.02	0.02	0.02
TV TUNER @ 13.75V	1	0.83	0.83		
TV TUNER	1	0.52	0.52	0.52	0.52

37-120 Electrical Load Analysis (continued)

B. 28V System Voltage (continued)

EQUIPMENT	QTY	CONTINUOUS AMPS EACH	INTERMITTENT AMPS EACH	CONTINUOUS TOTAL	INTERMITTENT TOTAL
ENG EQUIPMENT (14V BUS; continued)					
TV TUNER DISTRIBUTION AMP @ 13.75V	1	0.02	0.02		
TV TUNER DISTRIBUTION AMP	1	0.01	0.01	0.01	0.01
KRAMER VIDEO SWITCHER @ 13.75V	1	0.25	0.25		
KRAMER VIDEO SWITCHER	1	0.16	0.16	0.16	0.16
BURST ELECTRONICS VIDEO SWITCHER @ 13.75V	1	0.63	0.63		
BURST ELECTRONICS VIDEO SWITCHER	1	0.39	0.39	0.39	0.39
SONY VIDEO TAPE RECORDER @ 13.75V	1	2.16	2.16		
SONY VIDEO TAPE RECORDER	1	1.35	1.35	1.35	1.35
PANASONIC VIDEO TAPE RECORDER @ 13.75V	1	5.33	5.33		
PANASONIC VIDEO TAPE RECORDER	1	3.33	3.33	3.33	3.33

EQUIPMENT	QTY	CONTINUOUS AMPS EACH	INTERMITTENT AMPS EACH	CONTINUOUS TOTAL	INTERMITTENT TOTAL
ENG EQUIPMENT (5V BUS)					
VIDEO DISTRIBUTION AMPLIFIER @ 5V	1	0.50	0.50		
VIDEO DISTRIBUTION AMPLIFIER	1	0.11	0.11	0.11	0.11
SD MICRO CAM, RATIO CONV. @ 5V	2	0.66	0.66		
SD MICRO CAM, RATIO CONV.	2	0.15	0.15	0.29	0.29
SD MICRO CAM. UPCONVERTER @ 5V	2	0.70	0.70		
SD MICRO CAM. UPCONVERTER	2	0.16	0.16	0.31	0.31

37-130 Audio Alerts

All R44 helicopters have a low-RPM horn which sounds when rotor RPM is below 97%. The horn is muted when the collective is fully down. On earlier aircraft, the horn is provided by speakers in the side of the instrument console. On later aircraft, a tone generator in the audio system provides the horn through crew headsets.

Later aircraft include a high rotor RPM alert through the headsets. A warble tone (high/low tone) indicates rotor RPM is approaching 108%. A test button on the instrument panel permits pre-flight or in-flight testing of the high-RPM alert.

Additional audio alerts may be provided in the headsets depending on optional equipment installed, such as terrain warnings, traffic warnings, and autopilot modes.

37-140 Cockpit Camera

An optional video camera may be installed in the cabin ceiling. The camera records 4K video, intercom audio and radio communications, and GPS position both internally and to a removable flash drive inserted in the front of the camera housing. The internal memory retains only the most recent 3 hours of video and is not user-accessible. Recording starts automatically when the battery switch is turned on and stops when it is turned off.

Recording to the flash drive can be stopped or audio muted using the record and audio switches on the front of the camera housing. A switch in the down position turns off the associated function. Do not remove the flash drive while a recording is in progress as this will corrupt the video file. To remove a flash drive when the helicopter battery switch is on, first stop the recording using the record switch.

A blue flashing light on the camera housing indicates video is being recorded to the flash drive. A green steady light indicates the camera is powered and operating normally. The green light will change to an amber flashing light if an internal camera fault is detected, in which case video may not be recorded.

Video can be viewed on a Windows PC or Mac by removing the flash drive from the camera, inserting it into a USB port on a computer, and double clicking on the desired video file. Video is recorded in sequential 4 GB files with each file approximately 25 minutes in length. Video files are labeled HELICAM_XXXX.MP4, where XXXX is a sequential number. GPS position and altitude are recorded to files labeled HELICAM_XXXX.GPX on the flash drive, and are optionally displayed in the upper left hand corner of the video. A 128 GB flash drive (one supplied with each helicopter) will record approximately 13 hours of video. When full, the earliest video file is overwritten with the latest recording.

NOTE

Flash drives used with the camera must meet the criteria described in the Cockpit Camera User Guide in order to function reliably.

37-140 Cockpit Camera (continued)

Complete instructions are provided in the Cockpit Camera User Guide on the Robinson website <https://robinsonheli.com>. The guide also provides additional playback suggestions, instructions for visualizing GPS data, setting user preferences, and updating camera software, and video post-processing and troubleshooting tips. User options include on screen display of time & date and/or GPS position, time zone and daylight saving time status, and units for on screen display of GPS altitude.

37-150 Overspeed Protection

An engine start-up overspeed protection circuit is standard electrical equipment on R44 ship S/N 2625 & subsequent, R44 II ship S/N 14364 and 14412 & subsequent, and R44 Cadet ship S/N 30061 and 30071 & subsequent.

Engine start-up overspeeds typically occur if a start is initiated with the throttle open.

The start-up overspeed protection circuit is only active if the following 3 statements are true:

- C792 Engine rpm is above $90 \pm 3\%$
- C792 Rotor rpm is below $50 \pm 10\%$
- Clutch switch is Disengage i.e. wire 66 is routing power to wire 3003; refer to C024 Revision AS (or subsequent) schematic.

Start-up overspeed protection occurs when the C792-5 dual tachometer [internally] grounds pin 2 for 3s-5s, activating the F695-9 overspeed relay's coil and in turn grounding both magnetos' p-leads.

During flight, the start-up overspeed relay is disabled because the clutch switch is in the Engage position.

No periodic maintenance of the start-up overspeed protection circuit is required.

The start-up overspeed protection circuit cannot prevent all engine overspeeds.

37-160 Lycoming Electronic Ignition System (EIS)

Some aircraft are equipped with a Lycoming Electronic Ignition System (EIS). The EIS replaces the engine-left retard magneto & start booster. The remaining engine-right magneto provides redundant ignition, which eliminates the need for a back-up battery system.

Refer to Lycoming SI 1569 (current revision) for EIS instructions for continued airworthiness.

CHAPTER 38

AVIONICS

<u>Section</u>	<u>Title</u>	<u>Page</u>
38-10	Garmin G500H Electronic Flight Instrument System (EFIS) Installation	38.1
38-11	LRU Installation – Garmin Display Unit (GDU)	38.1
38-12	LRU Installation – GSU 75H ADAHRS	38.1
38-13	LRU Installation – GMU 44 Magnetometer	38.3
38-14	LRU Installation – GPS Installation	38.5
38-20	Garmin GTX 3X5 Transponder Installation	38.8
38-30	Garmin GMA 350Hc Audio Control Installation	38.10
38-40	Avionics for R44 Helicopter S/N 2363 & Subsequent and R44 II Helicopter S/N 13697, 13698, 13702, 13705 & Subsequent	38.11
38-41	C024 Electrical System Installation	38.11
38-42	C036 Electrical Components Installation	38.11
38-43	C058 Cyclic Grip Assembly	38.12
38-44	C800 Aspen PFD and MFD Installations	38.12
38-45	C802-2 COM Radio (Garmin GTR 225B) Installation	38.13
38-46	C803-1 ADS-B In Receiver (Garmin GDL 88) Installation	38.15
38-47	C804-15 Transponder (Garmin GTX 330 ES) Installation	38.17
38-48	C822-2 Audio Control (Garmin GMA 350H) Installation	38.20
38-49	C831 GPS (Garmin GTN 600/700 series) Installation	38.23
38-50	Optional Avionics	38.26
38-51	C807-1 King KTR 909 UHF Transceiver Installation	38.26
38-60	Avionics Software	38.29

Intentionally Blank

CHAPTER 38

AVIONICS

38-10 Garmin G500H Electronic Flight Instrument System (EFIS) Installation

The Garmin G500H is an integrated avionics display system that provides flight instrument, moving-map navigation, and additional situational awareness information to the flight crew via the Garmin Display Unit (GDU).

NOTE

Refer to Garmin G500H Instructions for Continued Airworthiness.

38-11 LRU Installation – Garmin Display Unit (GDU)

Refer to § 13-70 for GDU maintenance procedures.

38-12 LRU Installation – GSU 75H ADAHRS**A. Description**

The remote-mounted Garmin GSU 75H ADAHRS (Air Data, Attitude, and Heading Reference System) provides altitude, airspeed, attitude, and heading data to flight instrumentation.

B. Schematic

Refer to Figure 14-37 for Garmin GSU 75H ADAHRS Installation electrical schematic.

C. Removal

1. Turn battery & avionics switches off and pull out EFIS (5 amp) circuit breaker at panel.
2. Hinge left seat forward and remove C748-5 cover assembly.
3. Float ships: Remove screws securing F950-13 cover assembly to C232-3 floor and remove cover.
4. Disconnect airframe harness from GSU 75H ADAHRS at connectors.
5. Disconnect pitot and static tube fittings from ADAHRS and plug fittings.
6. Remove screws securing ADAHRS to F950-9 or F950-11 support assembly. Carefully remove ADAHRS from under left seat.

38-12 LRU Installation – GSU 75H ADAHRS (continued)

D. Installation

1. Turn battery & avionics switches off and pull out EFIS (5 amp) circuit breaker at panel.
2. Position GSU 75H ADAHRS on F950-9 or F950-11 support assembly and install screws. Verify security.
3. Remove plugs from fittings and connect pitot and static tube fittings to ADAHRS. Verify security. Perform pitot and static system leak checks per § 95-10.
4. Connect airframe harness to ADAHRS at connectors.
5. Float ships: Position F950-13 cover assembly on C232-3 floor and install screws. Verify security.
6. Push in EFIS circuit breaker (5 amp) at panel. Turn battery & avionics switches on.
7. Perform appropriate functional checks per Garmin G500H Instructions for Continued Airworthiness. Turn battery & avionics switches off.
8. Install C748-5 cover assembly and hinge left seat back.

E. Scheduled Maintenance and Inspections

Refer to Garmin G500H EFIS Maintenance Manual, Section 5 Periodic Maintenance.

NOTE

All factory-installed Garmin units are “on condition” and do not require scheduled periodic maintenance. Units feature a BIT (Built-In Test) function during each initial power-up that will detect internal failure(s) and alert pilot.

NOTE

Refer to § 38-60 for avionics software information.

F. Special Maintenance and Inspections

1. Turn battery & avionics switches off. Open circuit breaker panel, hinge left seat forward, and remove C748-5 cover assembly.
2. Inspect condition of and verify no obvious damage to GSU 75H ADAHRS, pitot-static tubes, circuit breaker, and wiring. Verify no loose, chafed, or broken wires or terminals. Verify no evidence of arcing. Verify equipment security.
3. Secure circuit breaker panel. Perform ground checks per Part D steps 5 thru 7.

38-13 LRU Installation – GMU 44 Magnetometer**A. Description**

The GMU 44 magnetometer senses the earth's magnetic field. Data is sent to the GSU 75H ADAHRS for processing to determine aircraft magnetic heading. This unit receives power directly from the GSU 75H ADAHRS and communicates with the GSU 75H ADAHRS using an RS-485 digital interface.

B. Schematic

Refer to Figure 14-37 for GSU 75H ADAHRS Installation electrical schematic.

C. Removal

1. Turn battery & avionics switches off and pull out EFIS (5 amp) circuit breaker at panel.
2. Remove tailcone cowling per § 4.300.
3. Supporting GMU 44 magnetometer, remove hardware securing magnetometer to F950-4 bracket.
4. Remove MS21919WDG12 clamp and disconnect magnetometer harness from F951-1 harness assembly at connectors. Remove magnetometer.

D. Installation

1. Turn battery & avionics switches off and pull out EFIS (5 amp) circuit breaker at panel.
2. Position MS21919WDG12 clamp on GMU 44 magnetometer connector.
3. Install hardware securing magnetometer to F950-4 bracket. Verify security.
4. Connect F951-1 harness assembly to magnetometer harness at connectors.
5. Push in EFIS circuit breaker (5 amp) at panel. Turn battery & avionics switches on.
6. Perform appropriate functional checks per Garmin G500H Instructions for Continued Airworthiness. Turn battery & avionics switches off.
7. Install tailcone cowling per § 4.300.

38-13 LRU Installation – GMU 44 Magnetometer (continued)**E. Scheduled Maintenance and Inspections**

Refer to Garmin G500H EFIS Maintenance Manual, Section 5 Periodic Maintenance.

NOTE

All factory-installed Garmin units are “on condition” and do not require scheduled periodic maintenance. Units feature a BIT (Built-In Test) function during each initial power-up that will detect internal failure(s) and alert pilot.

NOTE

Refer to § 38-60 for avionics software information.

F Special Maintenance and Inspections

1. Turn battery & avionics switches off. Open circuit breaker panel and remove tailcone cowling per § 4.300.
2. Inspect condition of and verify no obvious damage to Garmin GMU 44 magnetometer, circuit breaker, and wiring. Verify no loose, chafed, or broken wires or terminals. Verify no evidence of arcing. Verify equipment security.
3. Secure circuit breaker panel. Perform ground checks per Part D steps 5 thru 7.

38-14 LRU Installation – GPS Installation**NOTE**

Refer to Garmin GTN 600/700 Maintenance Manual and Instructions for Continued Airworthiness.

A. Description

The G500H system requires connection to at least one WAAS-enabled GPS receiver. Garmin's Wide Area Augmentation System (WAAS) utilizes ground reference stations that monitor GPS satellite data and issue correction messages which are broadcast via satellite to WAAS-enabled GPS receivers, improving accuracy, integrity, and availability.

One GTN 700-series, or one or two GTN 600-series, GPS(s) may be installed in the G060 upper console.

Also refer to § 38-49 for Garmin GTN 600/700 GPS Installation.

B. Schematic

Refer to Figure 14-38 for GTN 600/700 GPS Installation electrical schematic.

C. Removal

1. Turn battery & avionics switches off and pull out GPS 1 (5 amp) and GPS 2 (5 amp) circuit breakers as required at panel.
2. Loosen radio key securing GTN 600/700 GPS(s) to tray in upper console.
3. Carefully unplug/remove GPS(s) from tray.

D. Installation

1. Turn battery & avionics switches off and pull out GPS 1 (5 amp) and GPS 2 (5 amp) circuit breakers as required at panel.
2. Carefully plug-in/install GTN 600/700 GPS(s) in appropriate location in tray in upper console.
3. Tighten radio key securing GPS(s) to tray. Verify equipment security.
4. Push in GPS 1 (5 amp) and GPS 2 (5 amp) circuit breakers as required at panel. Turn battery & avionics switches on.
5. Perform appropriate functional checks per Garmin GTN 600/700 Pilot's Guide. Turn battery & avionics switches off.

38-14 LRU Installation – GPS Installation (continued)**E. Antenna**

Refer to § 16-70 for antenna locations & R44 Illustrated Parts Catalog (IPC) Chapter 6.

NOTE

Antenna installation depends on number of COM installations and additional equipment installed.

Removal

1. Turn battery & avionics switches off and pull out GPS 1 (5 amp) and GPS 2 (5 amp) circuit breakers as required at panel.
2. Using plastic scraper, remove B270-1 sealant from around GPS antenna at corners where it attaches to tailcone.
3. Disconnect antenna cable from antenna. As required, remove B270-13 sealant from fastener holes. Remove hardware securing antenna (and D322-3 spacers for NAV) to tailcone (or chin for glideslope) and remove antenna.

Installation

1. Turn battery & avionics switches off and pull out GPS 1 (5 amp) and GPS 2 (5 amp) circuit breakers as required at panel.
2. a. For GPS antenna:
 - i. Remove paint & primer from antenna mating surfaces to ensure electrical ground.
 - ii. As required, apply light coat B270-13 sealant to screw threads and install screws securing antenna to tailcone. As required, seal around screw heads and fill fastener holes using B270-13 sealant and allow to dry. Verify security.
 - iii. Apply small bead B270-1 sealant (0.1 inch max in height) around antenna at corners where it attaches to tailcone and allow to dry.
- b. For NAV antenna:
 - i. Install hardware and D322-3 spacers (slots down) securing antenna to tailcone. Verify security.
- c. For glideslope antenna:
 - i. Install screws securing antenna to chin. Verify security.
3. Connect antenna cable(s) to antenna. Verify security.
4. Perform ground checks per Part D steps 4 and 5.

38-14 LRU Installation – GPS Installation (continued)**F. Scheduled Maintenance and Inspections****NOTE**

All factory-installed Garmin units are “on condition” and do not require scheduled periodic maintenance. Units feature a BIT (Built-In Test) function during each initial power-up that will detect internal failure(s) and alert pilot.

NOTE

Refer to § 38-60 for avionics software information.

G. Special Maintenance and Inspections

1. Turn battery & avionics switches off. Open circuit breaker panel and upper console.
2. Inspect condition of and verify no obvious damage to GPS(s), copper bus bars, circuit breaker, and wiring. Verify no loose, chafed, or broken wires or terminals. Verify no evidence of arcing. Verify equipment security.
3. Secure circuit breaker panel and upper console. Perform ground checks per Part D steps 4 and 5.

38-20 Garmin GTX 3X5 Transponder Installation**NOTE**

Refer to Garmin GTX 3X5 ADS-B Maintenance Manual and Instructions for Continued Airworthiness.

A. Description

The Garmin GTX 3X5 have Extended Squitter (ES) ADS-B Out broadcast capability with options for a built-in WAAS GPS (ADS-B compliant).

The GTX 345 includes ADS-B In (traffic and weather) and Bluetooth® to transmit ADS-B data to wireless devices. Requires an independent display (such as GTN 600/700 GPS or wireless device) to view ADS-B In data.

B. Schematic

Refer to Figure 14-27 for Garmin GTX 3X5 Transponder Installation electrical schematic.

C. Removal

1. Turn battery & avionics switches off and pull out XPDR (3 amp) circuit breaker at panel.
2. Loosen radio key securing GTX 3X5 transponder to avionics tray.
3. Carefully unplug/remove transponder from tray.

D. Installation

1. Turn battery & avionics switches off and pull out XPDR (3 amp) circuit breaker at panel.
2. Carefully plug-in/install GTX 3X5 transponder in appropriate location in avionics tray.
3. Tighten radio key securing transponder to tray. Verify equipment security.
4. Push in XPDR (3 amp) circuit breaker at panel. Turn battery & avionics switches on.
5. Perform appropriate functional checks per Garmin GTX 3X5 ADS-B Maintenance Manual and Instructions for Continued Airworthiness. Turn battery & avionics switches off.

38-20 Garmin GTX 3X5 Transponder Installation (continued)**E. Antenna**

Refer to § 16-70 for antenna locations & R44 Illustrated Parts Catalog (IPC) Chapter 6.

NOTE

Antenna installation depends on optional equipment installed.

Removal

1. Turn battery & avionics switches off and pull out XPDR (3 amp) circuit breaker at panel.
2. Using plastic scraper, remove B270-1 sealant from around transponder antenna at corners where it attaches to B322-12 doubler.
3. Remove screws securing doubler to cabin skin and disconnect antenna cable from antenna. Remove hardware securing doubler to antenna and remove antenna.

Installation

1. Turn battery & avionics switches off and pull out XPDR (3 amp) circuit breaker at panel.
2. Remove paint & primer from between cabin skin and B322-12 doubler to ensure electrical ground.
3. Install hardware securing transponder antenna to doubler. Verify security. Apply small bead B270-1 sealant (0.1 inch max in height) around antenna at corners where it attaches to doubler and allow to dry.
4. Connect antenna cable to antenna and install screws securing mounting plate to cabin skin. Verify security.
5. Perform ground checks per Part D steps 4 and 5.

F. Scheduled Maintenance and Inspections**NOTE**

All factory-installed Garmin units are "on condition" and do not require scheduled periodic maintenance. Units feature a BIT (Built-In Test) function during each initial power-up that will detect internal failure(s) and alert pilot.

NOTE

Refer to § 38-60 for avionics software information.

38-20 Garmin GTX 3X5 Transponder Installation (continued)**G. Special Maintenance and Inspections**

1. Turn battery & avionics switches off. Open circuit breaker panel.
2. Remove GTX 33 transponder per Part C. Inspect condition of and verify no obvious damage to transponder, radio tray, copper bus bars, circuit breaker, and wiring. Verify no loose, chafed, or broken wires or terminals. Verify no evidence of arcing.
3. Secure circuit breaker panel. Install transponder per Part D.

38-30 Garmin GMA 350Hc Audio Control Installation**NOTE**

Refer to Garmin GMA 350Hc Maintenance Manual and Instructions for Continued Airworthiness.

A. Description of New Features

The Garmin GMA 350Hc audio control is a GMA 350H (refer to § 38-48) with Bluetooth® wireless technology.

B. Schematic

Refer to Figure 98-14 for Garmin GMA 350Hc Audio Control Installation electrical schematic.

C. Maintenance

Refer to § 38-48 C822-2 Audio Control (Garmin GMA 350H) Installation for maintenance instructions.

38-40 Avionics for R44 Helicopter S/N 2363 & Subsequent and R44 II Helicopter S/N 13697, 13698, 13702, 13705 & Subsequent**38-41 C024 Electrical System Installation****A. Description**

The main switch panel has rocker-style switches and is located above the radios on the avionics panel. An avionics master switch, located in the main switch panel near the alternator and battery switches, controls a relay which interrupts power to the avionics bus (system is fail-safe ON). The clutch actuator switch, the ignition switch, and also the clock are located on the upper console near the primary instruments. The outside air temperature/voltmeter is located on the upper console lower panel.

B. Schematic

Refer to Figure 14-21 for C024 electrical system schematic.

38-42 C036 Electrical Components Installation**A. Description****1. Instrument Lighting**

A light at the top of the windshield illuminates the instruments. Instrument lighting is active when the nav lights switch is on; a dimmer knob above the switch adjusts brightness.

a. LED-lamp replacement

- i. Remove hardware securing G196-6 light assembly to windshield stiffener. Remove two cap screws securing cover and LED-lamp assembly to housing. Disconnect lamp wires from airframe harness and remove lamp.
- ii. Connect C238-2289 (white) airframe harness wire to LED-lamp assembly red wire, and C238-2290 airframe harness wire to lamp black wire. Install cover (chamfer facing away from housing) and install two cap screws. Install hardware securing G196-6 light assembly bracket on windshield stiffener with bracket tilted up. Verify security.
- iii. Turn battery switch and NAV LIGHTS switch on and verify proper operation with dimmer knob. Turn battery switch and NAV LIGHTS switch off.

2. Full Throttle Caution (Amber) Light

Refer to § 37-70 for full throttle caution light rigging check and switch adjustment procedures.

B. Schematic

Refer to Figure 14-21 for C024 electrical system schematic.

38-43 C058 Cyclic Grip Assembly**A. Description**

The angle of the pilot's cyclic grip can be adjusted fore and aft relative to the cross tube. The most forward position provides the most control clearance at aft cyclic.

B. Grip Angle Adjustment

1. Loosen cap screws securing pilot's cyclic grip, block assembly, and bar to grip weldment.
2. Rotate grip about weldment to desired angle. Special torque cap screws to 40 in.-lb.

C. Removal and Installation

Refer to §§ 8.121 and 8.122 for cyclic grip assembly removal and installation procedures.

D. Schematic

Refer to Figure 14-21 for C024 electrical system schematic.

38-44 C800 Aspen PFD and MFD Installations

Refer to § 13.510 for Aspen PFD and MFD Installations.

A. Schematic

Refer to Figure 14-23 for C800-1 Aspen PFD Installation electrical schematic.

Refer to Figure 14-24 for C800-3 Aspen MFD Installation electrical schematic.

38-45 C802-2 COM Radio (Garmin GTR 225B) Installation

NOTE

Refer to Garmin GTR 225B Maintenance Manual and Instructions for Continued Airworthiness.

A. Description

The C802-2 COM radio (Garmin GTR 225B) has an airport frequency database, can monitor standby frequencies, and stores most-used frequencies. The C802-2 COM radio is a dual voltage unit, suitable for 14V and 28V systems.

B. Schematic

Refer to Figure 14-25 for C802-2 COM Radio Installation electrical schematic.

C. Removal

1. Turn battery switch off and pull-out COM radio circuit breaker (5 amp for 28 volt or 10 amp for 14 volt) at panel.
2. Loosen radio key securing C802-2 COM radio to avionics tray.
3. Carefully unplug/remove radio from tray.

D. Installation

1. Turn battery switch off and pull-out COM radio circuit breaker (5 amp for 28 volt or 10 amp for 14 volt) at panel.
2. Carefully plug-in/install C802-2 COM radio in appropriate location in avionics tray.
3. Tighten radio key securing radio to tray. Verify equipment security.
4. Push-in COM radio circuit breaker (5 amp for 28 volt or 10 amp for 14 volt) at panel. Turn battery and avionics switches on.
5. Perform appropriate functional checks per Garmin GTR 225B Pilot's Guide. Turn battery and avionics switches off.

E. Antenna

Refer to § 16-70 for antenna locations and R44 Illustrated Parts Catalog (IPC) Chapter 6.

NOTE

Antenna installation depends on number of COM installations and additional equipment installed.

38-45 C802-2 COM Radio (Garmin GTR 225B) Installation (continued)**E. Antenna (continued)**Removal

1. Turn battery switch off and pull out COM radio circuit breaker (5 amp for 28 volt or 10 amp for 14 volt) at panel.
2. Using plastic scraper, remove B270-1 sealant from around COM antenna at corners where it attaches to tailcone.
3. Disconnect antenna cable from antenna. As required, remove B270-13 sealant from fastener holes. Remove screws securing antenna to tailcone and remove antenna.

Installation

1. Turn battery switch off and pull out COM radio circuit breaker (5 amp for 28 volt or 10 amp for 14 volt) at panel.
2. Remove paint & primer from antenna mating surfaces to ensure electrical ground.
3. As required, apply light coat B270-13 sealant to screw threads and install screws securing antenna to tailcone. As required, seal around screw heads and fill fastener holes using B270-13 sealant and allow to dry. Verify security.
4. Apply small bead B270-1 sealant (0.1 inch max in height) around antenna at corners where it attaches to tailcone and allow to dry.
5. Connect antenna cable to antenna. Verify security.
6. Perform ground checks per Part D steps 4 and 5.

F. Scheduled Maintenance and Inspections**NOTE**

All factory-installed Garmin units are "on condition" and do not require scheduled periodic maintenance. Units feature a BIT (Built-In Test) function during each initial power-up that will detect internal failure(s) and alert pilot.

NOTE

Refer to § 38-60 for avionics software information.

G. Special Maintenance and Inspections

1. Turn battery & avionics switches off. Open circuit breaker panel & upper console.
2. Inspect condition of and verify no obvious damage to COM radio, radio tray, copper bus bars, circuit breaker, and wiring. Verify no loose, chafed, or broken wires or terminals. Verify no evidence of arcing. Verify equipment security.
3. Secure circuit breaker panel and upper console. Perform ground checks per Part D steps 4 and 5.

38-46 C803-1 ADS-B In Receiver (Garmin GDL 88) Installation

NOTE

Refer to Garmin GDL 88 Maintenance Manual and Instructions for Continued Airworthiness.

A. Description

Refer to § 38-47 for ADS-B system descriptions.

B. Schematic

Refer to Figure 14-26 for C803-1 ADS-B Installation electrical schematic.

C. Removal

1. Turn battery switch off and pull out XPDR circuit breaker (5 amp) at panel.
2. Under the left front seat, disconnect airframe harness from GDL 88 receiver at connectors.
3. Remove screws securing GDL 88 receiver to C904-1 mount assembly, and remove GDL 88 receiver.

D. Installation

1. Turn battery switch off and pull out XPDR circuit breaker (5 amp) at panel.
2. Under the left front seat, position GDL 88 receiver on C904-1 mount assembly and install screws. Verify security.
3. Connect airframe harness to GDL 88 receiver at connectors.
4. Push in XPDR circuit breaker (5 amp) at panel. Turn battery and avionics switches on.
5. Perform appropriate functional checks per Garmin GDL 88 Pilot's Guide. Turn battery and avionics switches off.

E. Antenna

Refer to § 16-70 for antenna locations and R44 Illustrated Parts Catalog (IPC) Chapter 6.

NOTE

Antenna installation depends on number of COM installations and additional equipment installed.

38-46 C803-1 ADS-B In Receiver (Garmin GDL 88) Installation (continued)**E. Antenna (continued)**Removal

1. Turn battery switch off and pull out XPDR circuit breaker (5 amp) at panel.
2. Using plastic scraper, remove B270-1 sealant from around GDL 88 antenna at corners where it attaches to belly.
3. Disconnect antenna cable from antenna. Remove hardware securing antenna to belly and remove antenna.

Installation

1. Turn battery switch off and pull out XPDR circuit breaker (5 amp) at panel.
2. Remove paint & primer from antenna mating surfaces to ensure electrical ground.
3. Install hardware securing antenna to belly. Apply small bead B270-1 sealant around antenna at corners where it attaches to belly and allow to dry.
4. Connect antenna cable to antenna. Verify security.
5. Perform ground checks per Part D steps 4 and 5.

F. Scheduled Maintenance and Inspections**NOTE**

All factory-installed Garmin units are "on condition" and do not require scheduled periodic maintenance. Units feature a BIT (Built-In Test) function during each initial power-up that will detect internal failure(s) and alert pilot.

NOTE

Refer to § 38-60 for avionics software information.

G. Special Maintenance and Inspections

1. Turn battery and avionics switches off. Open circuit breaker panel and access left front seat.
2. Inspect condition of and verify no obvious damage to GDL 88, circuit breaker, and wiring. Verify no loose, chafed, or broken wires or terminals. Verify no evidence of arcing. Verify equipment security.
3. Secure circuit breaker panel and left front seat. Perform ground checks per Part D steps 4 and 5.

38-47 C804-15 Transponder (Garmin GTX 330 ES) Installation**NOTE**

Refer to Garmin GTX 330 ES Maintenance Manual and Instructions for Continued Airworthiness.

A. Description

GPS-based Automatic Dependent Surveillance-Broadcast (ADS-B) Out equipment transmits information to air traffic control and ADS-B In equipment receives information from air traffic control or from other aircraft. The R44 may be equipped with ADS-B Out or with ADS-B Out and ADS-B In systems.

Both ADS-B systems operate mostly automatically. ADS-B equipment is programmed with aircraft specific-data at installation. ADS-B systems use the primary GPS for position information. Additional flight-specific data is entered by the pilot using transponder controls. ADS-B data is transmitted via the transponder's Extended Squitter (ES) on frequency 1090 MHz.

The ADS-B In system receives data via a receiver on frequencies 978 MHz and 1090 MHz. Received data (traffic and weather) is displayed on the primary GPS screen.

ADS-B Out equipment (transponder and primary GPS) or ADS-B Out and ADS-B In equipment (transponder, primary GPS, and receiver) must be powered and in normal operating modes for proper system function. ADS-B Out system faults are annunciated on the transponder and primary GPS screens. ADS-B In system faults are annunciated on the primary GPS screen.

Change of aircraft registration may require ADS-B equipment programming by qualified maintenance personnel.

Refer to R44 Pilot's Operating Handbook Section 9 for additional information.

B. Schematic

Refer to Figure 14-27 for C804 transponder & blind encoder electrical schematic.

C. Removal

1. Turn battery switch off and pull out XPDR circuit breaker (5 amp) at panel.
2. Loosen radio key securing C804-15 transponder to avionics tray.
3. Carefully unplug/remove transponder from tray.

38-47 C804-15 Transponder (Garmin GTX 330 ES) Installation (continued)**D. Installation**

1. Turn battery switch off and pull out XPDR circuit breaker (5 amp) at panel.
2. Carefully plug-in/install C804-15 transponder in appropriate location in avionics tray.
3. Tighten radio key securing transponder to tray. Verify equipment security.
4. Push in XPDR circuit breaker (5 amp) at panel. Turn battery & avionics switches on.
5. Perform appropriate functional checks per Garmin GTX 330 ES Pilot's Guide. Turn battery and avionics switches off.

E. Antenna

Refer to § 16-70 for antenna locations and R44 Illustrated Parts Catalog (IPC) Chapter 6.

NOTE

Antenna installation depends on optional equipment installed.

Removal

1. Turn battery switch off and pull out XPDR circuit breaker (5 amp) at panel.
2. Using plastic scraper, remove B270-1 sealant from around transponder antenna at corners where it attaches to B322-12 doubler.
3. Remove screws securing mounting plate to cabin skin and disconnect antenna cable from antenna. Remove hardware securing mounting plate to antenna and remove antenna.

Installation

1. Turn battery switch off and pull out XPDR circuit breaker (5 amp) at panel.
2. Remove paint & primer from between cabin skin and B322-12 doubler to ensure electrical ground.
3. Install hardware securing transponder antenna to mounting plate. Verify security. Apply small bead B270-1 sealant (0.1 inch max in height) around antenna at corners where it attaches to mounting plate and allow to dry.
4. Connect antenna cable to antenna and install screws securing mounting plate to cabin skin. Verify security.
5. Perform ground checks per Part D steps 4 and 5.

38-47 C804-15 Transponder (Garmin GTX 330 ES) Installation (continued)**F. Scheduled Maintenance and Inspections****NOTE**

All factory-installed Garmin units are “on condition” and do not require scheduled periodic maintenance. Units feature a BIT (Built-In Test) function during each initial power-up that will detect internal failure(s) and alert pilot.

NOTE

Refer to § 38-60 for avionics software information.

G. Special Maintenance and Inspections

1. Turn battery and avionics switches off. Open circuit breaker panel and upper console.
2. Inspect condition of and verify no obvious damage to transponder, radio tray, copper bus bars, circuit breaker, and wiring. Verify no loose, chafed, or broken wires or terminals. Verify no evidence of arcing. Verify equipment security.
3. Secure circuit breaker panel and upper console. Perform ground checks per Part D steps 4 and 5.

38-48 C822-2 Audio Control (Garmin GMA 350H) Installation**NOTE**

Refer to Garmin GMA 350H series Maintenance Manual and Instructions for Continued Airworthiness.

A. Description

The C822-2 audio control (Garmin GMA 350H) includes improved background noise suppression, 3D audio (if stereo headsets are used), and a manual ICS squelch mode to adjust audio thresholds for each occupant.

B. Schematic

Refer to Figure 14-29 for C822-2 audio control (Garmin GMA 350H) electrical schematic.

C. Removal

1. Turn battery switch off and pull out AUDIO PANEL circuit breaker (5 amp) at panel.
2. Loosen radio key securing Garmin GMA 350H audio control to avionics tray.
3. Carefully unplug/remove audio control from tray.

D. Installation

1. Turn battery switch off and pull out AUDIO PANEL circuit breaker (5 amp) at panel.
2. Carefully plug-in/install Garmin GMA 350H audio control in appropriate location in avionics tray.
3. Tighten radio key securing audio control to tray. Verify equipment security.
4. Push in AUDIO PANEL circuit breaker (5 amp) at panel. Turn battery & avionics switches on.
5. Perform appropriate functional checks per Garmin GMA 350H series Pilot's Guide. Turn battery & avionics switches off.

38-48 C822-2 Audio Control (Garmin GMA 350H) Installation (continued)**E. Antenna**

Refer to § 16-70 for marker beacon antenna location and R44 Illustrated Parts Catalog (IPC) Chapter 6.

Removal

1. Turn battery switch off and pull out AUDIO PANEL circuit breaker (5 amp) at panel.
2. Using plastic scraper, remove B270-1 sealant from around CI 102 marker beacon antenna at corners where it attaches to belly panel.
3. Remove hardware securing C794 forward belly panel to belly and disconnect C850-210 antenna cable from antenna. Remove screws securing antenna to panel and remove antenna.

Installation

1. Turn battery switch off and pull out AUDIO PANEL circuit breaker (5 amp) at panel.
2. Remove paint and primer from antenna mating surfaces to ensure electrical ground.
3. Apply light coat B270-11 adhesive to screw threads and install screws securing CI 102 marker beacon antenna to C794 forward belly panel. Verify security.
4. Connect C850-210 antenna cable to antenna. Install screws securing forward belly panel to belly. Verify security.
5. Apply small bead B270-1 sealant (0.1 inch max in height) around antenna at corners where it attaches to belly panel and allow to dry.
6. Perform ground checks per Part D steps 4 and 5.

F. Scheduled Maintenance and Inspections**NOTE**

All factory-installed Garmin units are "on condition" and do not require scheduled periodic maintenance. Units feature a BIT (Built-In Test) function during each initial power-up that will detect internal failure(s) and alert pilot.

NOTE

Refer to § 38-60 for avionics software information.

38-48 C822-2 Audio Control (Garmin GMA 350H) Installation (continued)**G. Special Maintenance and Inspections**

1. Turn battery and avionics switches off. Open circuit breaker panel and upper console.
2. Inspect condition of and verify no obvious damage to audio control, radio tray, copper bus bars, circuit breaker, and wiring. Verify no loose, chafed, or broken wires or terminals. Verify no evidence of arcing. Verify equipment security.
3. Secure circuit breaker panel and upper console. Perform ground checks per Part D steps 4 and 5.

38-49 C831 GPS (Garmin GTN 600/700 series) Installation**NOTE**

Refer to Garmin GTN 600/700 series Maintenance Manual and Instructions for Continued Airworthiness.

A. Description

The C831 GPS (Garmin GTN 600/700 series) interface is a combination of touch screen technology with traditional buttons and knobs. GTN 600/700 series GPS(s) may be installed in the pilot-side console location only. Note: R44 ADS-B Out system requires Garmin GTN 600/700 series GPS (refer to § 38-47).

B. Schematic

Refer to Figure 14-31 for C831 GPS (Garmin GTN 600/700 series) installation electrical schematic.

C. Removal

1. Turn battery switch off and pull out all COM circuit breakers (5 amp for 28 volt or 10 amp for 14 volt) and all GPS circuit breakers (5 amp for 28 volt or 7.5 amp for 14 volt) as required at panel.
2. Loosen radio key securing C831 GPS(s) to tray in pilot's side console.
3. Carefully unplug/remove GPS(s) from tray.

D. Installation

1. Turn battery switch off and pull out all COM circuit breakers (5 amp for 28 volt or 10 amp for 14 volt) and all GPS circuit breakers (5 amp for 28 volt or 7.5 amp for 14 volt) as required at panel.
2. Carefully plug-in/install C831 GPS(s) in appropriate location in tray in pilot's side console.
3. Tighten radio key securing GPS(s) to tray. Verify equipment security.
4. Push in all COM circuit breakers (5 amp for 28 volt or 10 amp for 14 volt) and all GPS circuit breakers (5 amp for 28 volt or 7.5 amp for 14 volt) as required at panel. Turn battery and avionics switches on.
5. Perform appropriate functional checks per Garmin GTN 600/700 series Pilot's Guide. Turn battery and avionics switches off.

38-49 C831 GPS (Garmin GTN 600/700 series) Installation (continued)**E. Antenna**

Refer to § 16-70 for antenna locations and R44 Illustrated Parts Catalog (IPC) Chapter 6.

NOTE

Antenna installation depends on number COM installations and additional equipment installed.

Removal

1. Turn battery switch off and pull out all COM circuit breakers (5 amp for 28 volt or 10 amp for 14 volt) and all GPS circuit breakers (5 amp for 28 volt or 7.5 amp for 14 volt) as required at panel.
2. Using plastic scraper, remove B270-1 sealant from around GPS antenna at corners where it attaches to tailcone.
3. Disconnect antenna cable from antenna. As required, remove B270-13 sealant from fastener holes. Remove screws securing antenna to tailcone and remove antenna.

Installation

1. Turn battery switch off and pull out all COM circuit breakers (5 amp for 28 volt or 10 amp for 14 volt) and all GPS circuit breakers (5 amp for 28 volt or 7.5 amp for 14 volt) as required at panel.
2. Remove paint & primer from antenna mating surfaces to ensure electrical ground.
3. As required, apply light coat B270-13 sealant to screw threads and install screws securing antenna to tailcone. As required, seal around screw heads and fill fastener holes using B270-13 sealant and allow to dry. Verify security.
4. Apply small bead B270-1 sealant (0.1 inch max in height) around antenna at corners where it attaches to tailcone and allow to dry.
5. Connect antenna cable to antenna. Verify security.
6. Perform ground checks per Part D steps 4 and 5.

38-49 C831 GPS (Garmin GTN 600/700 series) Installation (continued)**F. Scheduled Maintenance and Inspections****NOTE**

All factory-installed Garmin units are "on condition" and do not require scheduled periodic maintenance. Units feature a BIT (Built-In Test) function during each initial power-up that will detect internal failure(s) and alert pilot.

NOTE

Refer to § 38-60 for avionics software information.

G. Special Maintenance and Inspections

1. Turn battery and avionics switches off. Open circuit breaker panel. Remove hardware securing pilot's side console shell assembly to tray and carefully pivot shell assembly upward (GPS[s] and faceplate may be also be removed).
2. Inspect condition of and verify no obvious damage to GPS(s), tray, copper bus bars, circuit breaker, and wiring. Verify no loose, chafed, or broken wires or terminals. Verify no evidence of arcing. Verify equipment security.
3. Secure circuit breaker panel and pilot's side console. Perform ground checks per Part D steps 4 and 5.

38-50 Optional Avionics38-51 C807-1 King KTR 909 UHF Transceiver Installation**NOTE**

Refer to King KTR 909 UHF Transceiver Installation Manual.

A. Description

The C807-1 King KTR 909 UHF Transceiver is an AM UHF communications radio capable of receiving or transmitting voice or data within a 225 -399.975 MHz frequency range. Tuning information is supplied by the control unit located on the lower instrument panel.

B. Schematic

Refer to Figure 14-28 for C807-1 King KTR 909 UHF Transceiver electrical schematic.

C. Control UnitRemoval

1. Turn battery switch off and pull out COM circuit breaker (10 amp) at panel.
2. Open instrument console. Release tabs and unplug connectors from control unit.
3. Remove hardware securing control unit to lower panel and remove unit.

Installation

1. Turn battery switch off and pull out COM circuit breaker (10 amp) at panel.
2. Open instrument console. Position control unit on lower panel and install mounting hardware.
3. Plug connectors into control unit (tabs will lock). Verify equipment security.
4. Close instrument console.
5. Push in COM circuit breaker (10 amp) at panel. Turn battery & avionics switches on.
6. Perform appropriate functional checks per King KTR 909 UHF Transceiver Pilot's Guide. Turn battery & avionics switches off.

38-51 C807-1 King KTR 909 UHF Transceiver Installation (continued)**D. Transceiver**Removal

1. Hinge forward left seat forward and detach C748-5 cover assembly.
2. Disconnect coax cable from transceiver. Release tab and unplug connector from transceiver.
3. Loosen thumbscrew securing transceiver in mounting rack, hinge locking mechanism outboard, and slide transceiver outboard from rack.

Installation

1. Hinge forward left seat forward and detach C748-5 cover assembly.
2. On mounting rack, loosen thumbscrew and hinge locking mechanism outboard. Slide transceiver inboard onto rack. Hinge locking mechanism inboard and tighten thumbscrew. Verify security.
3. Plug connector into transceiver (tab will lock). Connect coax cable to transceiver.
4. Attach cover assembly and hinge seat forward.
5. Perform ground checks per Part C, Installation, steps 5 and 6.

E. Antenna

Refer to § 16-70 for antenna locations.

Removal

1. Turn battery switch off and pull out COM circuit breaker (10 amp) at panel.
2. Using plastic scraper, remove B270-1 sealant from around transceiver antenna at corners where it attaches to belly.
3. Hinge aft right seat forward and remove hardware securing C903-6 cover to compartment. Disconnect antenna cable from antenna.
4. Remove hardware securing antenna to belly and remove antenna.

38-51 C807-1 King KTR 909 UHF Transceiver Installation (continued)**E. Antenna (continued)**Installation

1. Turn battery switch off and pull out COM circuit breaker (10 amp) at panel.
2. Remove paint & primer from antenna mating surfaces to ensure electrical ground.
3. Install hardware securing antenna to belly. Apply small bead B270-1 sealant (0.1 inch max in height) around antenna at corners where it attaches to belly and allow to dry.
4. Connect antenna cable to antenna. Verify equipment security.
5. Position C903-6 cover in compartment and install mounting hardware. Verify security.
6. Perform ground checks per Part C, Installation, steps 5 and 6.

F. Scheduled Maintenance and Inspections**NOTE**

Refer to King KTR 909 UHF Transceiver Installation Manual.

G. Special Maintenance and Inspections

1. Turn battery and avionics switches off. Open circuit breaker panel and instrument console. Hinge forward left seat forward.
2. Inspect condition of and verify no obvious damage to transceiver, mounting tray, control unit, bus bars, circuit breaker, and wiring. Verify no loose, chafed, or broken wires or terminals. Verify no evidence of arcing. Verify equipment security.
3. Secure circuit breaker panel, instrument console, and forward left seat. Perform ground checks per Part C, Installation, steps 5 and 6.

38-60 Avionics Software

Modern avionics software is complex and subject to rigorous testing by RHC to assure proper function and integration in the aircraft. Only specified software versions and software configurations have been FAA-approved for installation in Robinson helicopters. Software updates should not be attempted without a thorough understanding of approval status and compatibility. Technical support from either RHC or the avionics manufacturer will likely be required. In some cases, updating software for one item of avionics may require additional avionics to be updated to assure compatibility.

As long as RHC-installed equipment is functioning properly, there is no continuing airworthiness requirement to check or update software levels in Robinson helicopters; RHC will issue an SB (or FAA will issue an AD) for any mandatory updates.

Consult www.robinsonheli.com > Customer Support > Avionics Support > Avionics Software page for approved software configurations.

NOTE

The above statements apply to avionics operating software. Databases (e.g. charts, terrain, etc.) may be updated regularly using avionics manufacturer's recommended procedures.

Intentionally Blank

CHAPTER 39

WIRING DIAGRAMS

<u>Section</u>	<u>Title</u>	<u>Page</u>
39-00	Description	39.1

Intentionally Blank

CHAPTER 39**WIRING DIAGRAMS**39-00 Description

Reserved.

Intentionally Blank

CHAPTER 40

SPECIAL TOOLS

<u>Section</u>	<u>Title</u>	<u>Page</u>
40-00	Description	40.1

Intentionally Blank

CHAPTER 40
SPECIAL TOOLS

40-00 Description

Refer to R44 Illustrated Parts Catalog (IPC) Chapter 99 Special Tools.

Intentionally Blank

CHAPTER 41
REVISION LOG

<u>Section</u>	<u>Title</u>	<u>Page</u>
41-00	Revision Log	41.1

Intentionally Blank

REVISION LOG

MAR 2024

The R44 Maintenance Manual (MM) list of effective pages and effective dates are given below. If a previously issued page is not listed below, it is no longer an effective page and must be discarded. The issue or revision date is in bold at the top of each revision log page.

Please visit <https://robinsonheli.com> to verify the issue or revision date is current.

<u>Page</u>	<u>Date</u>	<u>Page</u>	<u>Date</u>	<u>Page</u>	<u>Date</u>
i	MAR 2024	1.7	OCT 2006	2.9	DEC 2021
ii	MAR 2024	1.8	JUL 2008	2.10	DEC 2021
iii	AUG 2019	1.8A	OCT 2006	2.11	JAN 2021
iv	AUG 2019	1.8B	OCT 2006	2.12	JAN 2021
v	AUG 2019	1.8C	JUL 2004	2.13	DEC 2021
vi	AUG 2019	1.8D	06 Dec 99	2.14	DEC 2021
		1.8E	DEC 2021	2.15	DEC 2021
1.i	FEB 2024	1.8F	DEC 2021	2.16	DEC 2021
1.ii	FEB 2024	1.8G	DEC 2021	2.17	FEB 2024
1.1	AUG 2022	1.8H	DEC 2021	2.18	FEB 2024
1.2	AUG 2022	1.9	11 Jun 93	2.18A	DEC 2021
1.2A	FEB 2024	1.10	11 Jun 93	2.18B	DEC 2021
1.2B	FEB 2024	1.10A	1 Jun 97	2.19	AUG 2022
1.3	FEB 2024	1.10B	1 Jun 97	2.20	AUG 2022
1.3A	FEB 2024	1.11	OCT 2006	2.20A	SEP 2023
1.3B	FEB 2024	1.12	OCT 2006	2.20B	SEP 2023
1.3C	FEB 2024	1.13	FEB 2024	2.21	JUL 2008
1.3D	AUG 2022	1.14	FEB 2024	2.22	JUL 2008
1.3E	AUG 2022	1.15	FEB 2024	2.23	FEB 2024
1.3F	SEP 2023	1.16	FEB 2024	2.24	FEB 2024
1.3G	SEP 2023	1.17	FEB 2024	2.25	SEP 2023
1.3H	SEP 2023	1.18	FEB 2024	2.26	SEP 2023
1.3I	SEP 2023			2.26A	SEP 2023
1.3J	SEP 2023	2.i	AUG 2022	2.26B	SEP 2023
1.3K	SEP 2023	2.ii	AUG 2022	2.27	FEB 2024
1.3L	SEP 2023	2.1	FEB 2024	2.28	FEB 2024
1.3M	SEP 2023	2.2	FEB 2024	2.29	JUL 2021
1.3N	SEP 2023	2.3	FEB 2024	2.30	JUL 2021
1.3O	SEP 2023	2.4	FEB 2024	2.30A	JUL 2021
1.3P	AUG 2022	2.5	JAN 2021	2.30B	JUL 2021
1.4	AUG 2022	2.6	JAN 2021	2.31	DEC 2021
1.5	OCT 2006	2.7	JUL 2008	2.32	DEC 2021
1.6	OCT 2006	2.8	OCT 2006	2.33	DEC 2021

REVISION LOG

MAR 2024

<u>Page</u>	<u>Date</u>	<u>Page</u>	<u>Date</u>	<u>Page</u>	<u>Date</u>
2.34	DEC 2021	3.ii	FEB 2024	4.32	FEB 2024
2.35	DEC 2021	3.1	FEB 2024		
2.36	DEC 2021	3.2	FEB 2024	5.i	DEC 2011
2.36A	DEC 2021	3.3	FEB 2024	5.ii	DEC 2011
2.36B	DEC 2021	3.4	FEB 2024	5.1	DEC 2011
2.37	JUL 2021			5.2	DEC 2011
2.38	JUL 2021	4.i	FEB 2024	5.3	12 Dec 94
2.39	JUL 2008	4.ii	FEB 2024	5.4	11 Jun 93
2.40	JUL 2008	4.1	SEP 2023	5.5	11 Jun 93
2.41	OCT 2006	4.2	SEP 2023	5.6	12 Dec 94
2.42	OCT 2006	4.3	SEP 2023	5.7	11 Jun 93
2.43	OCT 2006	4.4	SEP 2023	5.8	12 Dec 94
2.44	OCT 2006	4.5	SEP 2023	5.9	06 Dec 99
2.45	FEB 2024	4.6	SEP 2023	5.10	06 Dec 99
2.46	FEB 2024	4.7	1 Jun 97	5.11	JUL 2008
2.47	FEB 2024	4.8	1 Jun 97	5.12	JUL 2008
2.48	FEB 2024	4.9	15 Jun 98	5.13	06 Dec 99
2.49	OCT 2006	4.10	11 Jun 93	5.14	06 Dec 99
2.50	OCT 2006	4.11	12 Dec 94	5.15	06 Dec 99
2.51	AUG 2022	4.12	12 Dec 94	5.16	06 Dec 99
2.52	AUG 2022	4.13	DEC 2011	5.17	DEC 2021
2.53	AUG 2022	4.14	DEC 2011	5.18	DEC 2021
2.54	AUG 2022	4.15	DEC 2011	5.19	06 Dec 99
2.55	DEC 2021	4.16	DEC 2011	5.20	06 Dec 99
2.56	DEC 2021	4.17	FEB 2024	5.21	OCT 2006
2.57	SEP 2023	4.18	FEB 2024	5.22	OCT 2006
2.58	SEP 2023	4.19	FEB 2024	5.23	JUL 2005
2.59	FEB 2024	4.20	FEB 2024	5.24	JUL 2005
2.60	FEB 2024	4.21	FEB 2024	5.25	JUL 2005
2.61	AUG 2022	4.22	FEB 2024	5.26	JUL 2005
2.62	AUG 2022	4.23	FEB 2024	5.27	JUL 2005
2.63	AUG 2022	4.24	FEB 2024	5.28	JUL 2005
2.64	AUG 2022	4.25	FEB 2024	5.29	JUL 2005
2.65	AUG 2022	4.26	FEB 2024	5.30	JUL 2005
2.66	AUG 2022	4.27	FEB 2024		
2.67	DEC 2021	4.28	FEB 2024	6.i	JUN 2014
2.68	DEC 2021	4.29	FEB 2024	6.ii	JUN 2014
		4.30	FEB 2024	6.1	JUN 2014
3.i	FEB 2024	4.31	FEB 2024	6.2	JUN 2014

REVISION LOG

MAR 2024

<u>Page</u>	<u>Date</u>	<u>Page</u>	<u>Date</u>	<u>Page</u>	<u>Date</u>
6.3	JUN 2014	7.9D	DEC 2011	7.44	12 Dec 94
6.4	JUN 2014	7.10	DEC 2011	7.45	12 Dec 94
6.5	JUN 2014	7.11	18 MAR 99	7.46	1 Jun 97
6.6	JUN 2014	7.12	12 Dec 94	7.47	JUL 2008
6.7	AUG 2022	7.13	DEC 2011	7.48	1 Jun 97
6.8	AUG 2022	7.14	DEC 2011	7.49	JUL 2008
6.9	JUN 2014	7.14A	18 MAR 99	7.50	JUL 2008
6.10	JUN 2014	7.14B	1 Jun 97	7.51	5 May 95
6.11	JUN 2014	7.15	DEC 2011	7.52	12 Dec 94
6.12	JUN 2014	7.16	DEC 2011	7.53	12 Dec 94
6.13	JUN 2014	7.17	DEC 2011	7.54	12 Dec 94
6.14	JUN 2014	7.18	DEC 2011		
6.15	JUN 2014	7.19	AUG 2022	8.i	DEC 2011
6.16	JUN 2014	7.20	AUG 2022	8.ii	DEC 2011
6.17	JUN 2014	7.21	AUG 2022	8.iii	DEC 2011
6.18	JUN 2014	7.22	AUG 2022	8.iv	DEC 2011
6.19	DEC 2021	7.23	SEP 2023	8.1	DEC 2021
6.20	DEC 2021	7.24	SEP 2023	8.1A	DEC 2021
6.21	JUN 2014	7.25	SEP 2023	8.1B	06 Dec 99
6.22	JUN 2014	7.26	SEP 2023	8.2	FEB 2003
6.23	JUN 2014	7.27	12 Dec 94	8.3	FEB 2003
6.24	JUN 2014	7.28	12 Dec 94	8.3A	06 Dec 99
		7.29	06 Dec 99	8.3B	JUL 2004
7.i	SEP 2023	7.30	1 Jun 97	8.4	15 Jun 98
7.ii	SEP 2023	7.31	12 Dec 94	8.5	15 Jun 98
7.1	DEC 2011	7.32	11 Jun 93	8.6	15 Jun 98
7.2	DEC 2011	7.33	15 Jun 98	8.7	11 Jun 93
7.3	5 May 95	7.34	1 Jun 97	8.8	06 Dec 99
7.4	12 Dec 94	7.35	15 Jun 98	8.9	1 Jun 97
7.5	JUL 2008	7.36	15 Jun 98	8.10	15 Jun 98
7.6	JUL 2008	7.37	1 Jun 97	8.11	15 Jun 98
7.7	15 Jun 98	7.38	12 Dec 94	8.12	15 Jun 98
7.8	18 MAR 99	7.39	AUG 2022	8.13	15 Jun 98
7.8A	DEC 2011	7.40	AUG 2022	8.14	15 Jun 98
7.8B	DEC 2011	7.40A	AUG 2022	8.15	15 Jun 98
7.9	DEC 2011	7.40B	AUG 2022	8.16	15 Jun 98
7.9A	DEC 2011	7.41	06 Dec 99	8.17	15 Jun 98
7.9B	DEC 2011	7.42	12 Dec 94	8.18	12 Dec 94
7.9C	DEC 2011	7.43	11 Jun 93	8.19	15 Jun 98

REVISION LOG

MAR 2024

<u>Page</u>	<u>Date</u>	<u>Page</u>	<u>Date</u>	<u>Page</u>	<u>Date</u>
8.20	15 Jun 98	8.55	OCT 2006	10.18	JUL 2008
8.21	15 Jun 98	8.56	JUL 2008	10.18A	JUL 2008
8.22	06 Dec 99	8.57	SEP 2023	10.18B	JUL 2008
8.23	12 Dec 94	8.58	SEP 2023	10.19	JUL 2008
8.24	11 Jun 93	8.59	SEP 2023	10.20	FEB 2003
8.25	JUL 2004	8.60	SEP 2023	10.21	12 Dec 94
8.26	JUL 2004	8.61	APR 2012	10.22	18 MAR 99
8.27	JUL 2004	8.62	APR 2012	10.23	2 Jul 93
8.28	JUL 2004	8.63	APR 2012	10.24	FEB 2003
8.29	JUL 2004	8.64	APR 2012	10.25	FEB 2003
8.30	JUL 2004	8.65	APR 2012	10.26	FEB 2003
8.31	FEB 2024	8.66	APR 2012	10.27	DEC 2021
8.32	FEB 2024	8.67	APR 2012	10.28	DEC 2021
8.32A	FEB 2024	8.68	APR 2012	10.29	DEC 2021
8.32B	FEB 2024			10.30	DEC 2021
8.33	SEP 2023	9.i	DEC 2021	10.31	DEC 2021
8.33A	SEP 2023	9.ii	DEC 2021	10.32	DEC 2021
8.33B	AUG 2022	9.1	DEC 2021	10.33	DEC 2021
8.34	AUG 2022	9.2	DEC 2021	10.34	DEC 2021
8.35	12 Dec 94			10.35	DEC 2021
8.36	JUL 2004	10.i	DEC 2021	10.36	DEC 2021
8.37	JUL 2008	10.ii	DEC 2021	10.37	DEC 2021
8.38	JUL 2008	10.1	DEC 2021	10.38	DEC 2021
8.39	JUL 2008	10.2	DEC 2021	10.39	DEC 2021
8.40	JUL 2008	10.3	AUG 2022	10.40	DEC 2021
8.41	JUL 2004	10.4	AUG 2022	10.41	DEC 2021
8.42	JUL 2004	10.5	AUG 2022	10.42	DEC 2021
8.43	11 Jun 93	10.6	AUG 2022	10.43	DEC 2021
8.44	JUL 2004	10.7	JUL 2008	10.44	DEC 2021
8.45	JUL 2004	10.8	FEB 2003	10.45	DEC 2021
8.46	11 Jun 93	10.9	OCT 2006	10.46	DEC 2021
8.47	11 Jun 93	10.10	FEB 2003	10.47	AUG 2022
8.48	11 Jun 93	10.11	JUL 2008	10.48	AUG 2022
8.49	JUL 2008	10.12	JUL 2008	10.49	DEC 2021
8.50	JUL 2008	10.13	11 Jun 93	10.50	DEC 2021
8.51	2 Jul 93	10.14	11 Jun 93		
8.52	5 May 95	10.15	OCT 2006	11.i	SEP 2023
8.53	OCT 2006	10.16	JUL 2008	11.ii	SEP 2023
8.54	OCT 2006	10.17	JUL 2008	11.1	DEC 2011

REVISION LOG

MAR 2024

<u>Page</u>	<u>Date</u>	<u>Page</u>	<u>Date</u>	<u>Page</u>	<u>Date</u>
11.2	DEC 2011	12.12B	FEB 2024	13.14	AUG 2019
11.3	1 Jun 97	12.13	FEB 2024	13.15	AUG 2019
11.4	1 Jun 97	12.14	FEB 2024	13.16	AUG 2019
11.5	1 Jun 97	12.15	DEC 2021	13.17	AUG 2019
11.6	1 Jun 97	12.16	DEC 2021	13.18	AUG 2019
11.7	SEP 2023	12.17	FEB 2024	13.19	AUG 2019
11.8	SEP 2023	12.18	FEB 2024	13.20	AUG 2019
11.8A	SEP 2023	12.19	DEC 2021	13.21	AUG 2019
11.8B	SEP 2023	12.20	DEC 2021	13.22	AUG 2019
11.9	OCT 2006	12.21	DEC 2021	13.23	AUG 2019
11.10	OCT 2006	12.22	DEC 2021	13.24	AUG 2019
11.11	OCT 2006	12.23	DEC 2021	13.25	AUG 2019
11.12	OCT 2006	12.24	DEC 2021	13.26	AUG 2019
11.13	OCT 2006	12.25	DEC 2021	13.27	AUG 2019
11.14	JUL 2008	12.26	DEC 2021	13.28	AUG 2019
11.15	OCT 2006	12.27	DEC 2021	13.29	AUG 2019
11.16	OCT 2006	12.28	DEC 2021	13.30	AUG 2019
11.17	OCT 2006	12.29	DEC 2021	13.31	AUG 2019
11.18	JUL 2008	12.30	DEC 2021	13.32	AUG 2019
11.19	OCT 2006	12.31	DEC 2021	13.33	AUG 2019
11.20	JUL 2008	12.32	DEC 2021	13.34	AUG 2019
11.21	JUL 2008	12.33	DEC 2021	13.35	AUG 2019
11.22	JUL 2008	12.34	DEC 2021	13.36	AUG 2019
				13.37	DEC 2021
				13.38	DEC 2021
12.i	FEB 2024	13.i	DEC 2021		
12.ii	FEB 2024	13.ii	DEC 2021		
12.1	DEC 2021	13.1	AUG 2019	14.i	JUL 2021
12.2	DEC 2021	13.2	AUG 2019	14.ii	JUL 2021
12.3	DEC 2021	13.3	AUG 2019	14.1	AUG 2019
12.4	DEC 2021	13.4	AUG 2019	14.2	AUG 2019
12.5	DEC 2021	13.5	AUG 2019	14.3	AUG 2019
12.6	DEC 2021	13.6	AUG 2019	14.3A	AUG 2019
12.7	FEB 2024	13.7	AUG 2019	14.3B	JUN 2014
12.8	FEB 2024	13.8	AUG 2019	14.3C	JUN 2014
12.9	DEC 2021	13.9	AUG 2019	14.3D	JUN 2014
12.10	DEC 2021	13.10	AUG 2019	14.3E	JUN 2014
12.11	FEB 2024	13.11	AUG 2019	14.3F	JUN 2014
12.12	FEB 2024	13.12	AUG 2019	14.3G	JUN 2014
12.12A	FEB 2024	13.13	AUG 2019	14.3H	JUN 2014

REVISION LOG

MAR 2024

<u>Page</u>	<u>Date</u>	<u>Page</u>	<u>Date</u>	<u>Page</u>	<u>Date</u>
14.3I.....	JUN 2014	14.29.....	15 Jun 98	14.64.....	AUG 2022
14.17.....	OCT 2006	14.30.....	11 Jun 93	14.65.....	AUG 2019
14.17A.....	OCT 2006	14.31.....	11 Jun 93	14.66.....	AUG 2019
14.17B.....	OCT 2006	14.32.....	11 Jun 93	14.67.....	AUG 2019
14.18.....	OCT 2006	14.33.....	11 Jun 93	14.68.....	AUG 2019
14.18A.....	OCT 2006	14.34.....	11 Jun 93	14.69.....	AUG 2019
14.18B.....	OCT 2006	14.35.....	11 Jun 93	14.70.....	AUG 2019
14.18C.....	JUL 2008	14.36.....	12 Dec 94	14.71.....	AUG 2019
14.18D.....	OCT 2006	14.37.....	11 Jun 93	14.72.....	AUG 2019
14.19.....	JUL 2004	14.38.....	11 Jun 93	14.73.....	AUG 2019
14.19A.....	JUL 2004	14.39.....	1 Jun 97	14.74.....	AUG 2019
14.19B.....	JUL 2004	14.40.....	1 Jun 97	14.75.....	AUG 2019
14.20.....	11 Jun 93	14.40A.....	OCT 2006	14.76.....	AUG 2019
14.20A.....	18 MAR 99	14.40B.....	OCT 2006	14.77.....	JAN 2021
14.20B.....	15 Jun 98	14.41.....	FEB 2024	14.78.....	JAN 2021
14.20C.....	18 MAR 99	14.42.....	FEB 2024		
14.20D.....	15 Jun 98	14.43.....	AUG 2019	15.i.....	DEC 2021
14.20E.....	JUL 2004	14.44.....	AUG 2019	15.ii.....	DEC 2021
14.20F.....	18 MAR 99	14.45.....	AUG 2019	15.1.....	DEC 2021
14.20G.....	JUL 2004	14.46.....	AUG 2019	15.2.....	DEC 2021
14.20H.....	JUL 2004	14.47.....	AUG 2019	15.3.....	JAN 2021
14.20I.....	DEC 2011	14.48.....	AUG 2019	15.4.....	JAN 2021
14.20J.....	DEC 2011	14.49.....	AUG 2019	15.5.....	JAN 2021
14.20K.....	JUN 2014	14.50.....	AUG 2019	15.6.....	JAN 2021
14.20L.....	JUN 2014	14.51.....	AUG 2019	15.7.....	JAN 2021
14.20M.....	JUN 2014	14.52.....	AUG 2019	15.8.....	JAN 2021
14.20N.....	JUN 2014	14.53.....	AUG 2019	15.9.....	JAN 2021
14.20O.....	JUN 2014	14.54.....	AUG 2019	15.10.....	JAN 2021
14.20P.....	JUN 2014	14.55.....	AUG 2019	15.11.....	JAN 2021
14.20Q.....	JUN 2014	14.56.....	AUG 2019	15.12.....	JAN 2021
14.20R.....	JUN 2014	14.57.....	AUG 2019	15.13.....	JAN 2021
14.21.....	JUL 2021	14.58.....	AUG 2019	15.14.....	JAN 2021
14.22.....	JUL 2021	14.59.....	AUG 2019	15.15.....	DEC 2021
14.23.....	JUL 2021	14.60.....	AUG 2019	15.16.....	DEC 2021
14.24.....	JUL 2021	14.61.....	AUG 2019		
14.25.....	AUG 2019	14.62.....	AUG 2019	16.i.....	FEB 2024
14.26.....	AUG 2019	14.62A.....	AUG 2022	16.ii.....	FEB 2024
14.27.....	11 Jun 93	14.62B.....	AUG 2022	16.1.....	FEB 2024
14.28.....	11 Jun 93	14.63.....	AUG 2022	16.2.....	FEB 2024

REVISION LOG

MAR 2024

<u>Page</u>	<u>Date</u>	<u>Page</u>	<u>Date</u>	<u>Page</u>	<u>Date</u>
16.3	FEB 2024	20.2	AUG 2019	23.26	DEC 2021
16.4	FEB 2024			23.27	DEC 2021
16.5	FEB 2024	21.i	AUG 2019	23.28	DEC 2021
16.6	FEB 2024	21.ii	AUG 2019	23.29	SEP 2023
16.7	FEB 2024	21.1	AUG 2019	23.30	SEP 2023
16.8	FEB 2024	21.2	AUG 2019	23.31	SEP 2023
				23.32	SEP 2023
17.i	FEB 2024	22.i	AUG 2019	23.33	SEP 2023
17.ii	FEB 2024	22.ii	AUG 2019	23.34	SEP 2023
17.1	FEB 2024	22.1	AUG 2019	23.35	DEC 2021
17.2	FEB 2024	22.2	AUG 2019	23.36	DEC 2021
17.3	FEB 2024			23.37	FEB 2024
17.4	FEB 2024	23.i	SEP 2023	23.38	FEB 2024
17.5	FEB 2024	23.ii	SEP 2023	23.39	FEB 2024
17.6	FEB 2024	23.1	DEC 2021	23.40	FEB 2024
		23.2	DEC 2021	23.41	DEC 2021
18.i	FEB 2024	23.3	DEC 2021	23.42	DEC 2021
18.ii	FEB 2024	23.4	DEC 2021	23.43	DEC 2021
18.1	FEB 2024	23.5	AUG 2022	23.44	DEC 2021
18.2	FEB 2024	23.6	AUG 2022	23.45	FEB 2024
18.3	FEB 2024	23.7	SEP 2023	23.46	FEB 2024
18.4	FEB 2024	23.8	SEP 2023		
18.5	MAR 2024	23.9	SEP 2023	24.i	SEP 2023
18.6	MAR 2024	23.10	SEP 2023	24.ii	SEP 2023
18.7	MAR 2024	23.11	FEB 2024	24.1	AUG 2022
18.8	MAR 2024	23.12	FEB 2024	24.2	AUG 2022
18.9	FEB 2024	23.13	SEP 2023	24.3	AUG 2022
18.10	FEB 2024	23.14	SEP 2023	24.4	AUG 2022
18.11	FEB 2024	23.15	DEC 2021	24.5	AUG 2022
18.12	FEB 2024	23.16	DEC 2021	24.6	AUG 2022
		23.17	DEC 2021	24.7	AUG 2022
19.i	AUG 2019	23.18	DEC 2021	24.8	AUG 2022
19.ii	AUG 2019	23.19	DEC 2021	24.9	AUG 2022
19.1	AUG 2019	23.20	DEC 2021	24.10	AUG 2022
19.2	AUG 2019	23.21	DEC 2021	24.11	SEP 2023
		23.22	DEC 2021	24.12	SEP 2023
20.i	AUG 2019	23.23	DEC 2021	24.13	SEP 2023
20.ii	AUG 2019	23.24	DEC 2021	24.14	SEP 2023
20.1	AUG 2019	23.25	DEC 2021	24.15	SEP 2023

REVISION LOG

MAR 2024

<u>Page</u>	<u>Date</u>	<u>Page</u>	<u>Date</u>	<u>Page</u>	<u>Date</u>
24.16	SEP 2023	27.22	SEP 2023	28.36	DEC 2021
				28.37	DEC 2021
25.i	AUG 2019	28.i	DEC 2021	28.38	DEC 2021
25.ii	AUG 2019	28.ii	DEC 2021	28.39	DEC 2021
25.1	AUG 2019	28.1	DEC 2021	28.40	DEC 2021
25.2	AUG 2019	28.2	DEC 2021	28.41	DEC 2021
		28.3	DEC 2021	28.42	DEC 2021
26.i	FEB 2024	28.4	DEC 2021	28.43	DEC 2021
26.ii	FEB 2024	28.5	DEC 2021	28.44	DEC 2021
26.1	FEB 2024	28.6	DEC 2021		
26.2	FEB 2024	28.7	DEC 2021	29.i	AUG 2019
26.3	FEB 2024	28.8	DEC 2021	29.ii	AUG 2019
26.4	FEB 2024	28.9	DEC 2021	29.1	AUG 2019
26.5	FEB 2024	28.10	DEC 2021	29.2	AUG 2019
26.6	FEB 2024	28.11	DEC 2021		
		28.12	DEC 2021	30.i	DEC 2021
27.i	SEP 2023	28.13	DEC 2021	30.ii	DEC 2021
27.ii	SEP 2023	28.14	DEC 2021	30.1	DEC 2021
27.1	SEP 2023	28.15	DEC 2021	30.2	DEC 2021
27.2	SEP 2023	28.16	DEC 2021	30.3	DEC 2021
27.3	SEP 2023	28.17	DEC 2021	30.4	DEC 2021
27.4	SEP 2023	28.18	DEC 2021	30.5	DEC 2021
27.5	SEP 2023	28.19	DEC 2021	30.6	DEC 2021
27.6	SEP 2023	28.20	DEC 2021	30.7	DEC 2021
27.7	SEP 2023	28.21	DEC 2021	30.8	DEC 2021
27.8	SEP 2023	28.22	DEC 2021	30.9	DEC 2021
27.9	SEP 2023	28.23	DEC 2021	30.10	DEC 2021
27.10	SEP 2023	28.24	DEC 2021	30.11	DEC 2021
27.11	SEP 2023	28.25	DEC 2021	30.12	DEC 2021
27.12	SEP 2023	28.26	DEC 2021	30.13	DEC 2021
27.13	SEP 2023	28.27	DEC 2021	30.14	DEC 2021
27.14	SEP 2023	28.28	DEC 2021	30.15	DEC 2021
27.15	SEP 2023	28.29	DEC 2021	30.16	DEC 2021
27.16	SEP 2023	28.30	DEC 2021	30.17	DEC 2021
27.17	SEP 2023	28.31	DEC 2021	30.18	DEC 2021
27.18	SEP 2023	28.32	DEC 2021	30.19	DEC 2021
27.19	SEP 2023	28.33	DEC 2021	30.20	DEC 2021
27.20	SEP 2023	28.34	DEC 2021	30.21	DEC 2021
27.21	SEP 2023	28.35	DEC 2021	30.22	DEC 2021

REVISION LOG

MAR 2024

<u>Page</u>	<u>Date</u>	<u>Page</u>	<u>Date</u>	<u>Page</u>	<u>Date</u>
30.23	DEC 2021	36.10	AUG 2019	37.30	AUG 2019
30.24	DEC 2021			37.31	AUG 2019
		37.i	FEB 2024	37.32	AUG 2019
31.i	AUG 2019	37.ii	FEB 2024	37.33	FEB 2024
31.ii	AUG 2019	37.1	JAN 2021	37.34	FEB 2024
31.1	AUG 2019	37.1A	JAN 2021		
31.2	AUG 2019	37.1B	SEP 2023	38.i	AUG 2019
		37.2	SEP 2023	38.ii	AUG 2019
32.i	AUG 2019	37.2A	SEP 2023	38.1	AUG 2019
32.ii	AUG 2019	37.2B	SEP 2023	38.2	AUG 2019
32.1	AUG 2019	37.2C	AUG 2022	38.3	AUG 2019
32.2	AUG 2019	37.2D	AUG 2022	38.4	AUG 2019
		37.3	AUG 2019	38.5	AUG 2019
33.i	AUG 2019	37.4	AUG 2019	38.6	AUG 2019
33.ii	AUG 2019	37.5	AUG 2019	38.7	AUG 2019
33.1	AUG 2019	37.6	AUG 2019	38.8	AUG 2019
33.2	AUG 2019	37.7	DEC 2021	38.9	AUG 2019
		37.8	DEC 2021	38.10	AUG 2019
34.i	AUG 2019	37.9	JAN 2021	38.11	AUG 2019
34.ii	AUG 2019	37.10	JAN 2021	38.12	AUG 2019
34.1	AUG 2019	37.11	AUG 2019	38.13	AUG 2019
34.2	AUG 2019	37.12	AUG 2019	38.14	AUG 2019
		37.13	AUG 2019	38.15	AUG 2019
35.i	AUG 2019	37.14	AUG 2019	38.16	AUG 2019
35.ii	AUG 2019	37.15	AUG 2019	38.17	AUG 2019
35.1	AUG 2019	37.16	AUG 2019	38.18	AUG 2019
35.2	AUG 2019	37.17	DEC 2021	38.19	AUG 2019
		37.18	DEC 2021	38.20	AUG 2019
36.i	AUG 2019	37.19	AUG 2019	38.21	AUG 2019
36.ii	AUG 2019	37.20	AUG 2019	38.22	AUG 2019
36.1	AUG 2019	37.21	AUG 2019	38.23	AUG 2019
36.2	AUG 2019	37.22	AUG 2019	38.24	AUG 2019
36.3	SEP 2023	37.23	AUG 2019	38.25	AUG 2019
36.4	SEP 2023	37.24	AUG 2019	38.26	AUG 2019
36.5	SEP 2023	37.25	AUG 2019	38.27	AUG 2019
36.6	SEP 2023	37.26	AUG 2019	38.28	AUG 2019
36.7	JAN 2021	37.27	AUG 2019	38.29	AUG 2019
36.8	JAN 2021	37.28	AUG 2019	38.30	AUG 2019
36.9	AUG 2019	37.29	AUG 2019		

REVISION LOG

MAR 2024

<u>Page</u>	<u>Date</u>	<u>Page</u>	<u>Date</u>	<u>Page</u>	<u>Date</u>
39.i	AUG 2019				
39.ii	AUG 2019				
39.1	AUG 2019				
39.2	AUG 2019				
40.i	AUG 2019				
40.ii	AUG 2019				
40.1	AUG 2019				
40.2	AUG 2019				
41.i	DEC 2021				
41.ii	DEC 2021				
41.1	MAR 2024				
41.2	MAR 2024				
41.3	MAR 2024				
41.4	MAR 2024				
41.5	MAR 2024				
41.6	MAR 2024				
41.7	MAR 2024				
41.8	MAR 2024				
41.9	MAR 2024				
41.10	MAR 2024				