

R44-series Governor Controller Upgrade Kit Instructions

Kit installs D270-1 Governor controller which supersedes D278-1 & -2 controllers. EMU interface provides additional engine speed & manifold pressure data. KI-274-2A is eligible for installation on R44 S/N 2624 & prior and Cadet S/N 30070 & prior. KI-274-2B is eligible for Raven II S/N 14411 & prior. A programmed D270-1.CS (indicated by a completed D682-47 decal on controller) will be sent with kit if helicopter serial number is provided with order. Alternately, programming may be accomplished per <https://robinsonheli.com> >Publications >User Guides >R22 & R44 EMU.

NOTE

Visit <https://robinsonheli.com/> to verify kit instructions are current revision. Review instructions before installation; contact RHC Technical Support with questions. Verify kit contents match list; contact RHC Customer Service if parts are missing or damaged.

ITEM	PART NUMBER	KIT CONTENTS	QTY PER KI-274-2A (R44)	QTY PER KI-274-2B (R44 II)
1	KI-274-2Instr.	Kit Instructions	1	1
2	B267-3	Solder Sleeve – Terminator (includes [1] spare)	2	2
3	B269-66	Connector – Socket (HD)	4	4
4	C143-6	Sensor Assembly	1	1
5	C357-7	Clip Assembly	1	1
6	D270-1.CS	Controller Assembly - Governor	1	1
7	D842-2	Governor Harness Assembly (R44, including Cadet)	1	0
8	D842-3	Governor Harness Assembly (R44 II)	0	1
9	D845-2	Harness Assembly – Tool (labeled “HIGH DENSITY PIN TOOL”)	1	1
10	D845-3	Harness Assembly	1	1
11	KI-274-54	Governor (EMU) MAP Line Sub-Assembly Includes: [1] A729-54 Tube (35-inch length) [2] B158-4 Heat Shrink, (marked "MAP") [2] B158-4 Heat Shrink, (marked "KI-274-54")	1	1
12	1589-01C	Cable	1	1
13	40-4-2-N-O	Elbow	1	1
14	45-4-2-N-O	Elbow	1	1
15	60-4-2-N-O	Tee	1	1
16	61183	Gasket (Lycoming part number)	1	1
17	STD-8	Washer (Lycoming part number)	6	6
18	STD-160	Lockwasher (Lycoming part number)	4	4
19	STD-1411	Nut (Lycoming part number)	4	4
20	STD-1856	Bolt (Lycoming part number, includes lockwasher)	2	2
21	MS3367-4-9+	Ty-Rap (Note: “+” in part number indicates 20-qty pack).	1	1
22	MS3367-5-9+	Ty-Rap (Note: “+” in part number indicates 20-qty pack).	1	1
23	MS3367-7-9+	Ty-rap (Note: “+” in part number indicates 10-qty pack)	1	1
24	MS21042L08	Nut	4	4

ITEM	PART NUMBER	KIT CONTENTS (Continued)	QTY PER KI-274-2A (R44)	QTY PER KI-274-2B (R44 II)
25	MS27039C0805	Screw	4	4
26	MS35206-214+	Screw (Note: "+" in part number indicates 10-qty pack)	1	1
27	NAS557-14A	Grommet	1	1
28	NAS1149FN816P+	Washer (Note: "+" in part number indicates 20-qty pack)	1	1

Consumables

Refer to R44 Maintenance Manual (MM) § 23-70 for approved materials list.

- B270-5 Sealant
- B270-6 Sealant

Special Tools

- Wire stripping tool
- Drilling and deburring tools
- Step drill, 3/16 inch–7/8 inch size range
- Hand crimping tool for high density circular signal contacts (AMP P/N 601966-1 or equivalent)
- Crimp die F (DMC P/N M22520/2-09 or equivalent)
- 10X magnifier (RHC P/N 10XMAG, or equivalent)
- Adjustable heat gun with reflector [nozzle] capable of 400°F-700°F
- MT700-1 cup assembly - oil drain (optional; available for purchase from RHC)

Kit Instructions

1. Turn battery switch OFF & pull GOV circuit breaker on circuit breaker panel. Disconnect negative (ground) cable from battery MM § 37-10.
2. Remove existing D278 governor controller per MM § 8.231.
3. Refer to Figure 1. Position D270-1.CS governor controller on C679-3 cover as shown and align with existing inboard hole. Mark (3) remaining hole locations on cover. Remove governor controller.
4. Drill (3) 0.169–0.175 inch diameter holes at marked locations. Deburr holes and clean up debris.
5. Refer to Figure 2. Starting at newly drilled hole location indicated in Figure 2, layout USB connector hole dimensions as shown. Drill (1) 0.625 inch diameter hole using step drill and (2) 0.125–0.135 inch diameter holes in cover as shown. Deburr holes and clean up debris.
6. Refer to Figure 3. Apply light coat B270-6 sealant to 40-4-2-N-O elbow threads (do not apply sealant to first thread). Install 40-4-2-N-O elbow onto governor controller. Tighten connection and position.
7. Install governor controller and secure using (4) MS27039C0805 screws, (4) NAS1149FN816P washers, and (4) MS21042L08 nuts.
8. Refer to R44 Illustrated Parts Catalog (IPC) Figure 6-11. Remove C474-2 cover panel to gain access to tunnel. For Cadet helicopter configuration, remove C474-4 panel per MM § 36-10B.

Kit Instructions (continued)

NOTE

Proper length of KI-274-54 governor MAP line is determined on installation; avoid removing "MAP" & "KI-274" markings when shortening MAP line.

9. Refer to Figures 3 and 4. Connect KI-274-54 governor MAP line to 40-4-2-N-O elbow as shown. Route governor MAP line to tunnel and along existing MAP line. Choose a suitable location on existing MAP line to connect governor MAP line. Cut existing MAP line and install 60-4-2-N-O tee. Trim governor MAP line as required. Install 45-4-2-N-O elbow and connect elbow to tee. Tighten connections.
10. Remove C377-1 LH and C378 RH engine cowling assemblies.
11. Remove and retain B123-2 filter. Exercise care when removing filter to avoid oil spillage. MT700-1 cup assembly may be used to catch & divert oil. Cover filter adapter.
12. Refer to Figure 5. Remove 60430 vacuum-pump cover & existing 61183 gasket cover from engine accessory housing. Position C143-6 sensor with engraved "UP" marking as shown. Install sensor with new 61183 gasket between engine and sensor, using (4) STD-8 washers, (4) STD-160 lockwashers, and (4) STD-1411 nuts. Torque nuts to 96 in-lb.
13. Secure C143-5 sensor connector to clip using (2) MS35206-214 screws. Remove upper bolts & associated washers securing D723-1 adapter assembly. Install C357-7 clip assembly using supplied STD-1856 bolts as shown in Figure 5, Detail A. Torque bolts to 96 in-lb.
14. Install retained B123-2 filter per instructions on filter housing, or replace with new filter, as required.
15. Connect D845-3 harness assembly to C143-6 sensor. Route bare end of D845-3 harness assembly wire (-2886) forward along airframe harness and thru vertical firewall, moving B270-5 sealant as required. Secure harness assembly to airframe harness (engine-compartment side) using appropriately-sized ty-raps as required. Ensure harness has sufficient slack and does not preload wires.

NOTE

If pushing wire (-2886) thru vertical firewall is difficult: temporarily remove sheet-metal clamps & existing nylon grommet where longitudinal harness penetrates firewall, then install supplied NAS557-14A grommet in firewall hole (to protect harness). After inserting (-2886) wire, remove NAS557-14A grommet then reinstall sheet metal clamps & existing grommet on harness.

16. Refer to Figure 6. In aft tunnel, approximately three inches forward of vertical firewall, locate MS21919WDG22 clamp around longitudinal (fore-aft) harness. Carefully remove ty-raps from longitudinal harness aft of clamp and three inches forward of clamp. Remove & retain clamp and hardware.

Kit Instructions (continued)**NOTE**

Parenthetic dash numbers, such as (-2886), indicate number marked on wiring insulation (if single conductor), or jacket (if multi-conductor and/or shielded).

17. Route wire (-2886) of D845-3 harness assembly forward along airframe harness; loop wire aft along airframe harness and thru grommet of C351-1 brace (ref IPC Figure 25-1). Install & secure MS21919WDG22 clamp around longitudinal (fore-aft) harness approximately three inches forward of vertical firewall, also securing wire D845-3 harness to airframe harness. As required, install MS3367-7-9 ty-raps around longitudinal harness forward & aft of clamp. Ensure D845-3 harness has sufficient slack and does not preload wires. Cinch ty-raps until snug without over-tightening, and trim tips flush with heads.
18. Remove ty-raps as required from D842 harness assembly. Route wires (-2886) along D842 harness assembly to governor Using D842 controller wire harness as a guide, trim wire (-2886) of D845-3 harness slightly longer than length of controller wire harness.

CAUTION

Trimmed shielding strands are conductive. Prevent contaminating connectors or wiring by holding a vacuum hose adjacent to wire to capture debris during cutting.

19. Refer to Figure 7. On bare end of D845-3 harness assembly wire (-2886): Lightly score (cut without fully penetrating) white outer jacket approximately 1.75 inches from end. Twist scored jacket until score opens, then remove jacket to expose underlying, braided shielding. Push shielding toward remaining jacket to create flange in shielding (A). Using cutters as shown in (B), remove shielding flange then slide off loose shielding to expose inner, insulated wires. Verify complete removal of shielding by inspection using 10X magnification.
20. Remove outer reinforcing fibers, spread inner wires, and remove inner reinforcing fibers. Slide a B267-3 terminator a few inches over remaining jacket so attached black-striped shield drain wire points toward exposed inner wires (C). Score jacket ¼ inch from stripped jacket end, being careful not to damage shielding or internal wires (D). Remove scored ¼ inch jacket piece, exposing shielding ¼ inch beyond outer jacket.
21. Refer to Figure 8. Slide terminator into position, so inner solder sleeve is centered on exposed shielding. Using heat gun, apply 700°F heat to terminator until both solder sleeve & indicator ring are completely melted (or until solder sleeve melts & red color disappears, as applicable). Allow to cool. Trim black-striped wire to same length as adjacent wires (-2886).
22. Refer to Figure 9. Disconnect large silver backshell & connector from D842-2 or -3 controller harness assembly. Remove (4) screws securing cover and (2) screws securing clamp; remove backshell from connector.
23. Hold black heat shrink and slide black expansion sleeve away from both connector & heat shrink, then gently slide heat shrink away from connector. Using 10X magnification, examine connector's insulation block and note embossed location numbers.

Kit Instructions (continued)

24. Strip 0.18-inch insulation from (-2886) wires. Crimp (1) B269-66 HD socket onto orange-striped, blue-striped, black-striped, & white wires. Using 10X magnification, inspect crimps per MM § 23-84. Verify no nicked or broken conductors (wire strands), and no insulation damage.
25. Refer to Figures 10 & 11. At connector, insert ends of D845-3 harness assembly wire (-2886) thru GOV heat shrink and black expansion sleeve, and:
 - a. Insert socket on blue-striped wire into governor connector location 20; verify security.
 - b. Insert socket on orange-striped wire into governor connector location 7; verify security.
 - c. Insert socket on white wire into governor connector location 6; verify security.
 - d. Insert socket on shield wire (black-stripped) into governor connector location 21; verify security.
26. Slide black expansion sleeve under heat shrink to within 1-inch of connector and apply 400°F heat using heat gun. Assemble backshell on connector. Ensure GOV heat shrink is clamped. Ensure both backshell flange & cover flange retains connector.
27. Connect ohmmeter positive lead to ring terminal of D845-2 tool. Touch ohmmeter's negative lead to pin on D845-2 tool and verify continuity ("CLOSED" circuit); remove ohmmeter's negative lead from pin and verify infinite resistance ("open" circuit) Refer to Appendix A to complete continuity check.
28. Install appropriately-sized ty-raps as required to secure installation to airframe harness. Cinch ty-raps until snug without over-tightening, and trim tips flush with heads
29. Restore retained B270-5 sealant around harness exit on aft side of vertical firewall, adding additional sealant as required.
30. With second person manipulating flight controls thru range of travel, verify clearance between harnesses and controls. Correct any discrepancies.
31. Refer to Figure 3. Connect D842 harness assembly to existing main wire harness connector (for previous D278 governor controller). Route and install wire (-2926) to ground screw on C351-1 brace and secure using existing hardware.
32. Connect D842 governor harness assembly to new governor controller. Secure governor harness along main harness using appropriately-sized ty-raps. Cinch ty-rap until snug without over-tightening, and trim tip flush with head.
33. Install 1589-01C cable to governor controller. Secure cable's USB port to C679-3 cover using screws supplied with cable as shown.
34. Perform manifold pressure system leak check per MM §13-25E.
35. Inspect engine for oil leaks; adjust engine oil quantity as required.
36. Install C377-1 LH, & C378 RH engine cowling assemblies, and control tunnel access panels.
37. Install LH aft seatback per MM § 15.220.

Kit Instructions (continued)

38. Push in GOV circuit breaker on circuit breaker panel. Connect negative (ground) cable from battery per MM § 37-10.
39. Revise helicopter's Weight and Balance Record in Pilot's Operating Handbook (POH) Section 6 to reflect this installation by incorporating the following data:

Remove:

Item	Weight	Long. Arm	Long. Moment	Lat. Arm	Lat. Moment
D278 Governor Controller	-1.05 lb	90.04 in.	-94.54 in-lb	-12.38 in.	13.00 in-lb

Add:

Item	Weight	Long. Arm	Long. Moment	Lat. Arm	Lat. Moment
KI-274-2 R44-series Governor Controller Conversion Kit	+0.68 lb	87.72 in.	57.90 in-lb	-9.20 in.	-6.07 in-lb

40. Functional test governor controller by having appropriately rated person run-up helicopter in accordance with POH. Upon successful ground check, a rated pilot may optionally evaluate governor performance in flight.
41. Make appropriate maintenance record entries.
42. D270 controller's engine RPM historical data may be viewed by appropriate software; refer to <https://robinsonheli.com> >Publications >User Guides >R22 & R44 EMU.

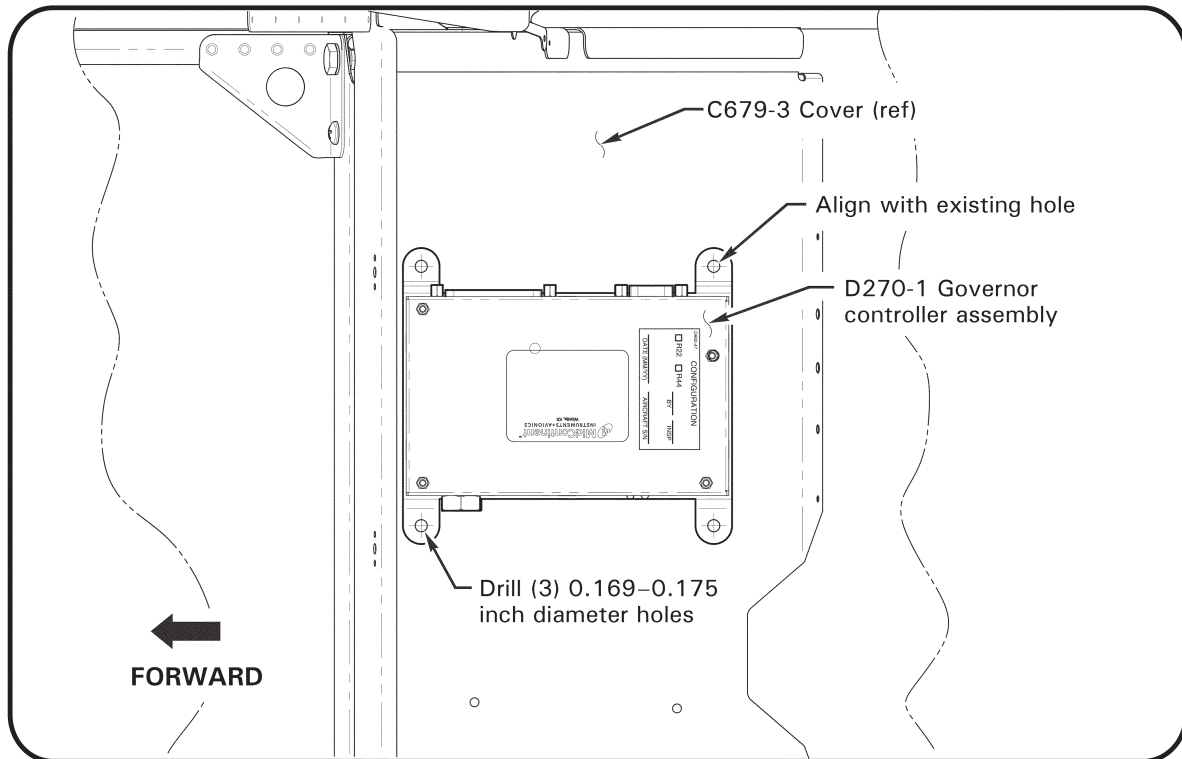

FIGURE 1 D270-1 Governor controller location
(View looking down behind LH aft seat)

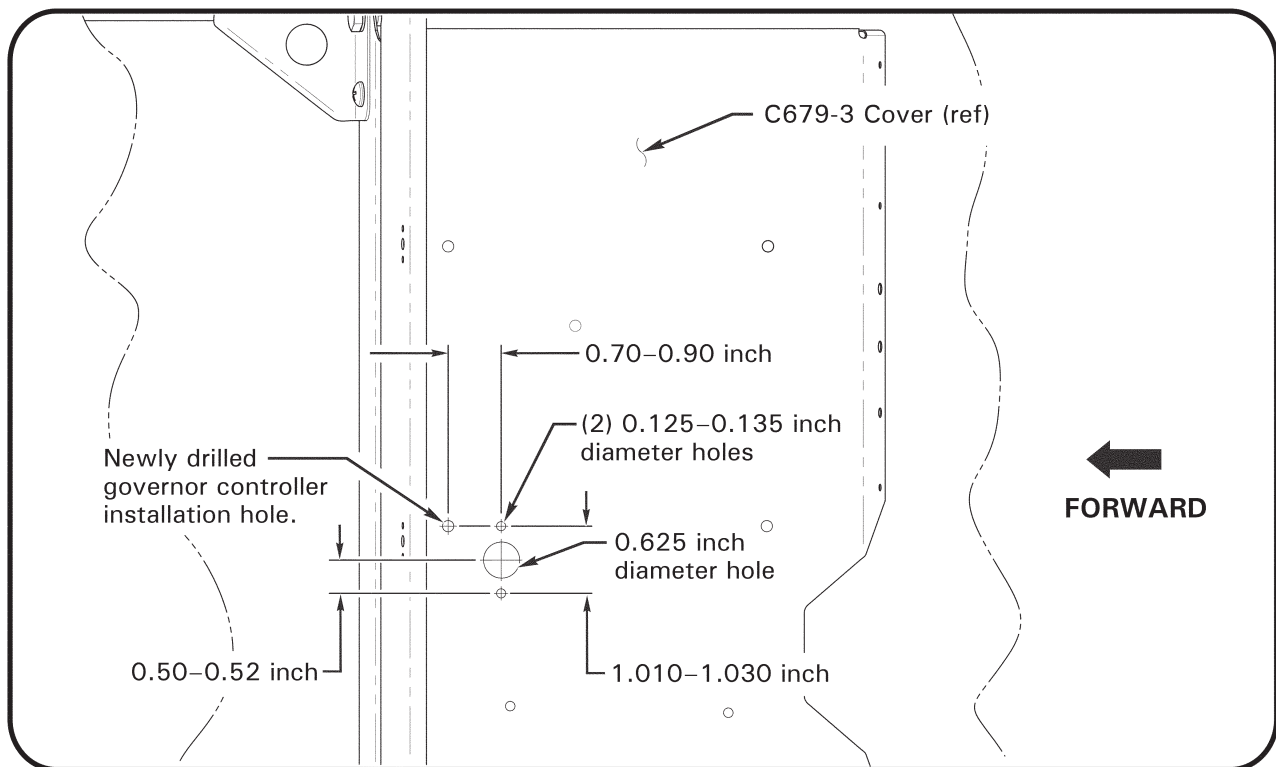

FIGURE 2 USB connector hole location
(View looking down behind LH aft seat)

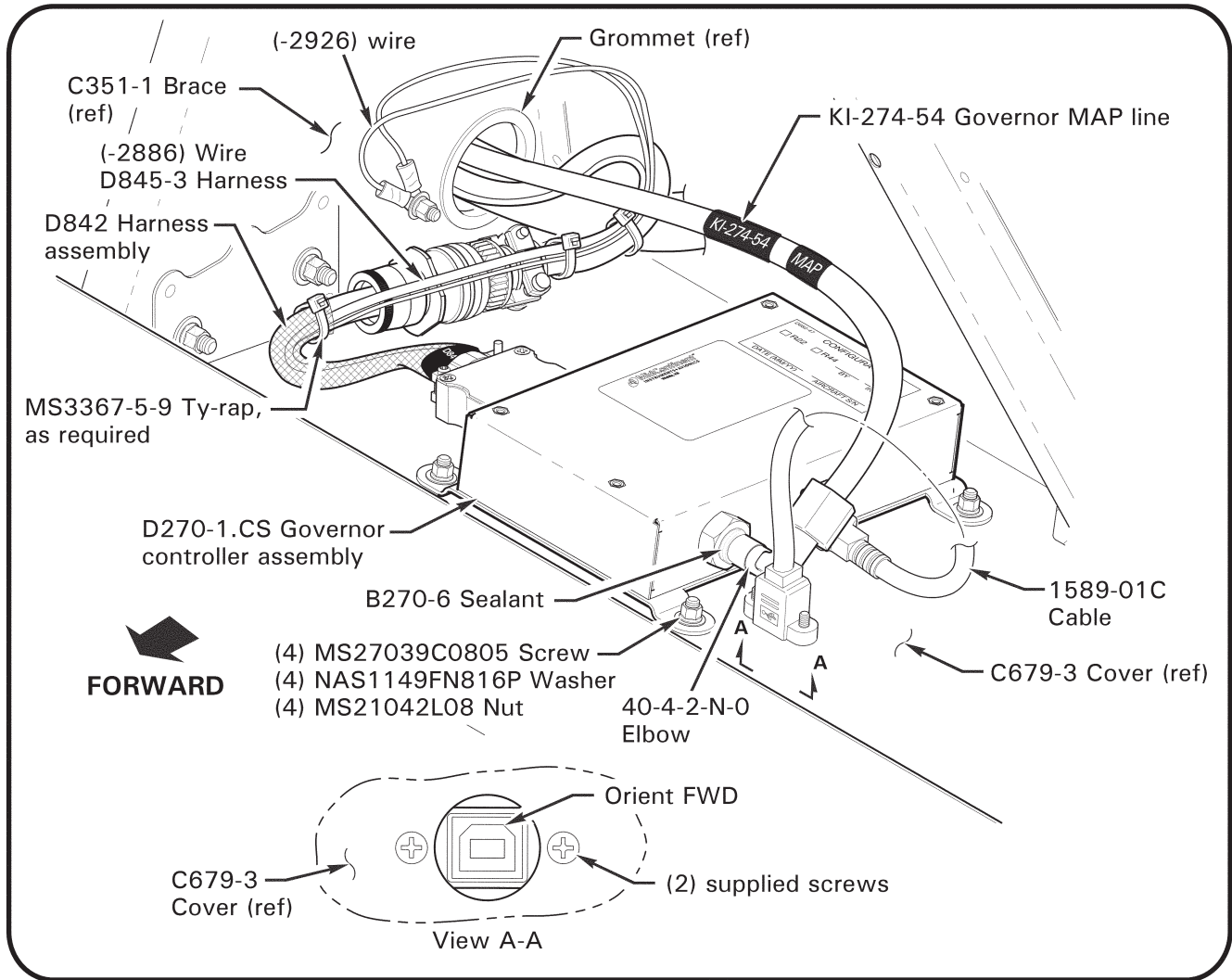

Figure 3 D270-1 Governor controller installation

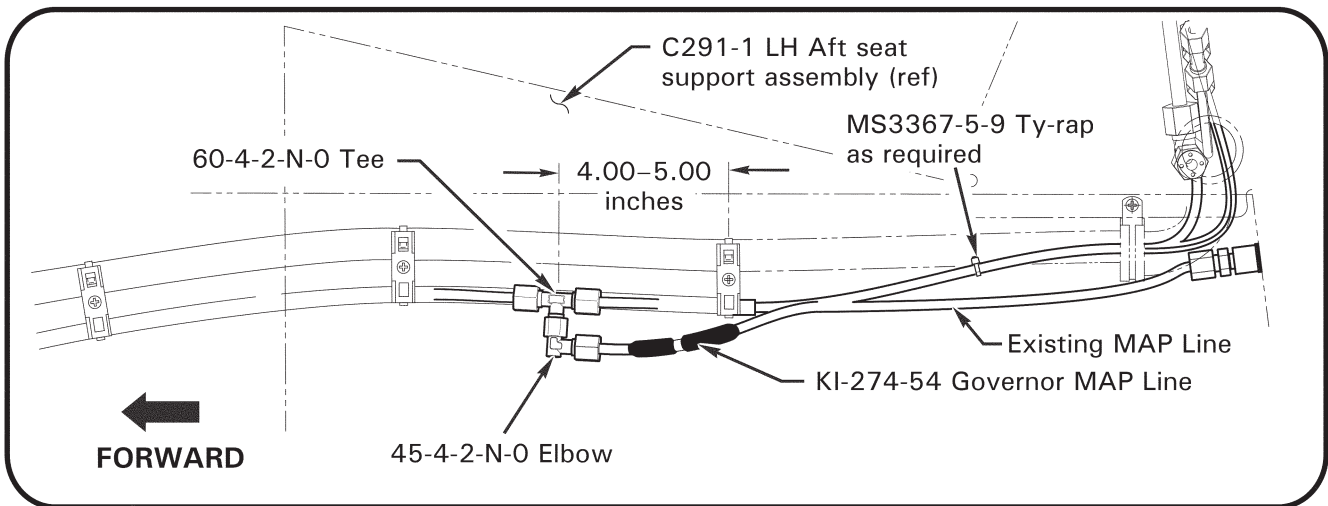

Figure 4 KI-274-54 Governor MAP line installation

(View looking inboard from LH aft baggage compartment. LH keel panel not shown for clarity.)

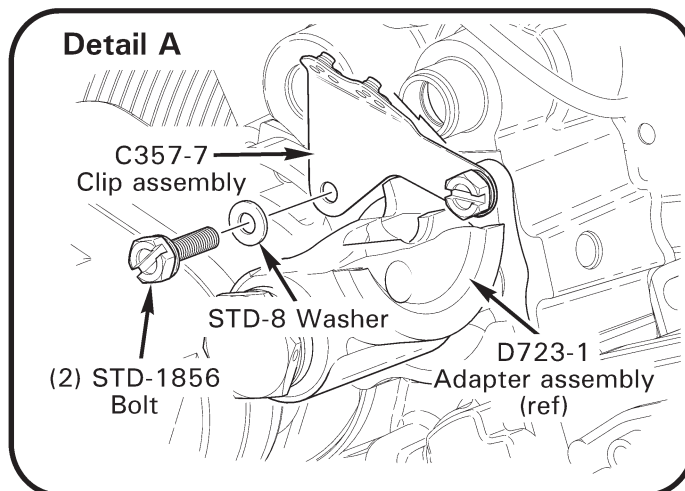
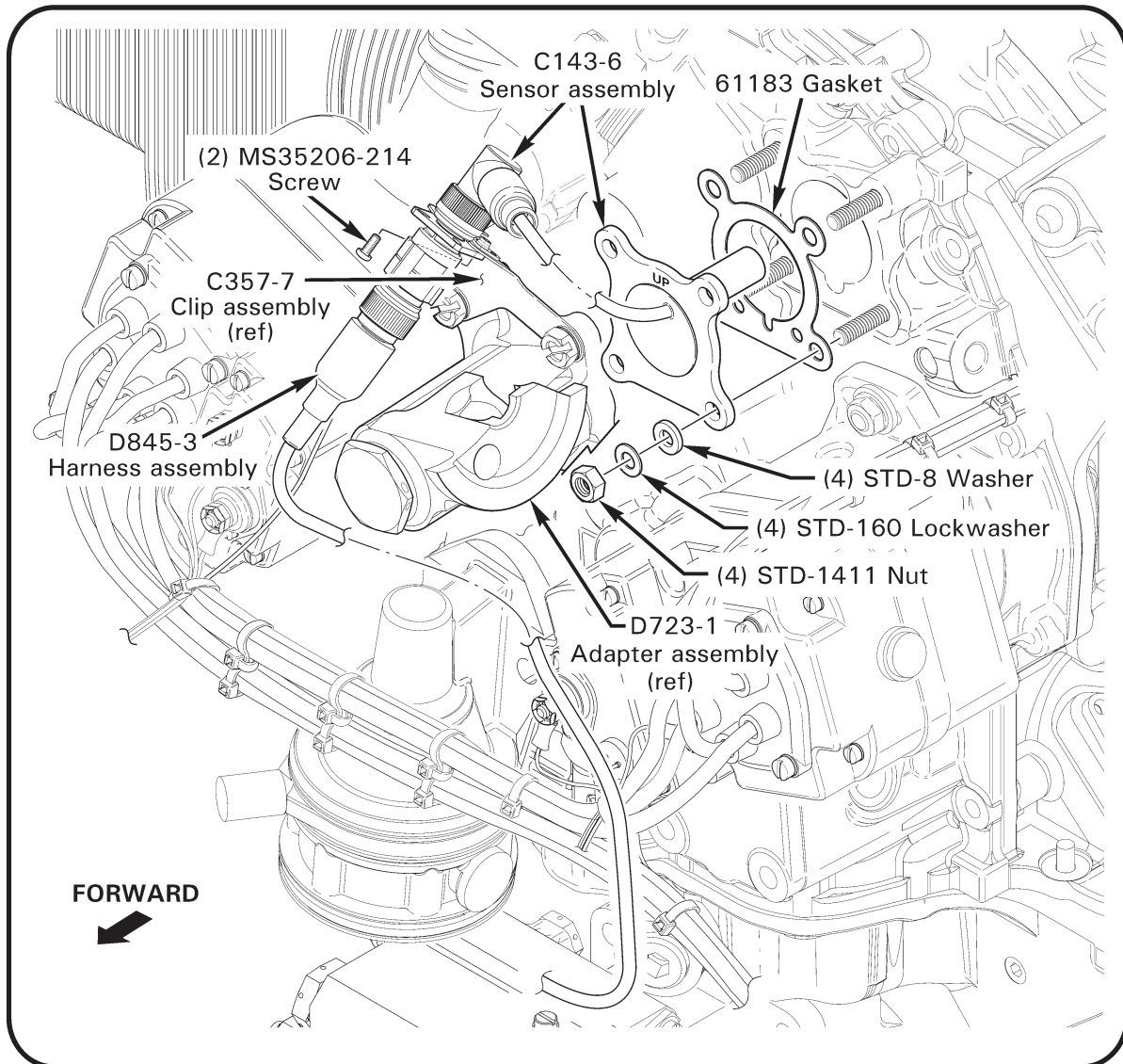

FIGURE 5 C143-6 sensor & C357-7 clip assemblies installed
(view looking aft; oil filter removed for clarity)

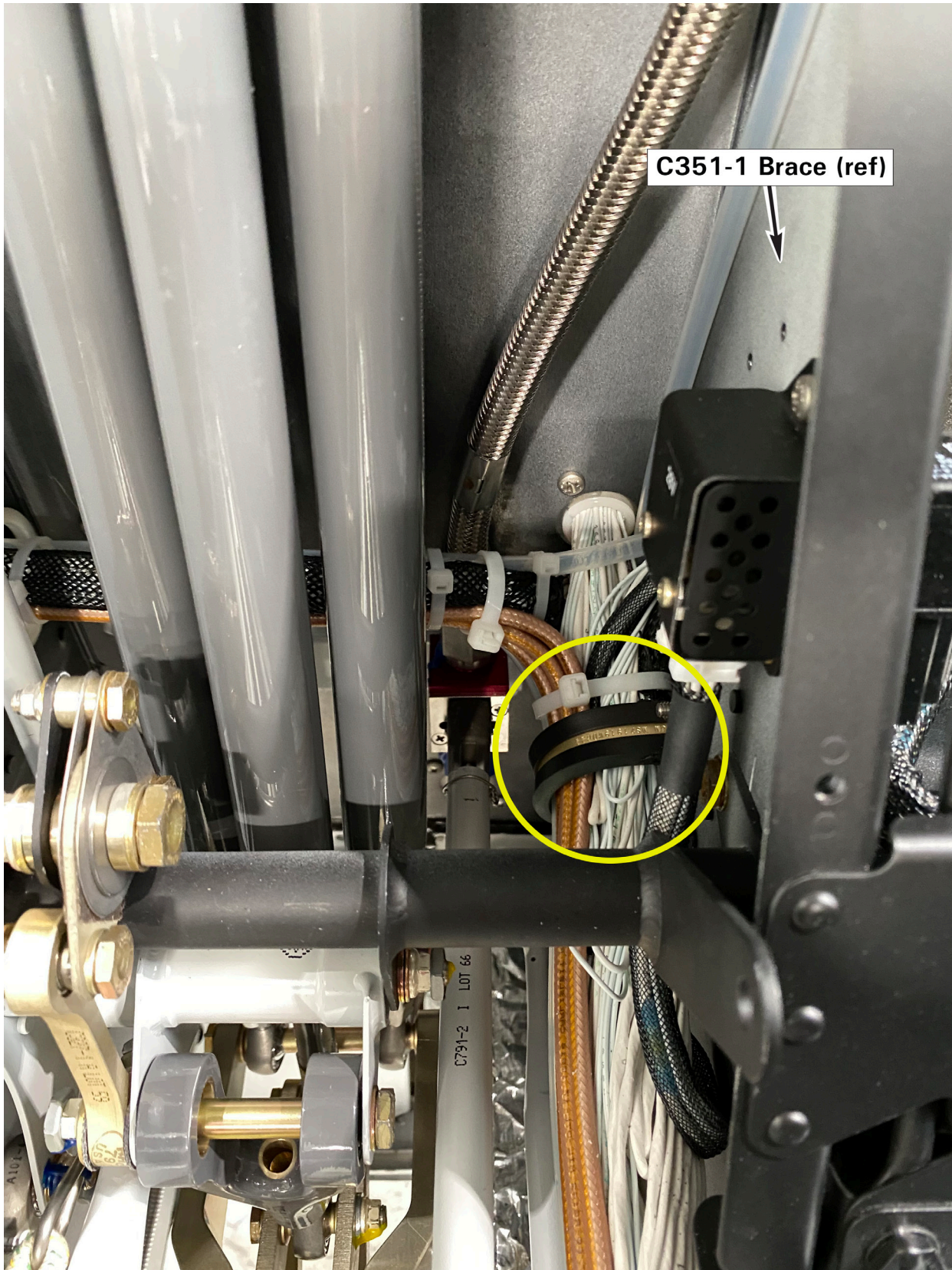

FIGURE 6 Location of clamp, ty-rap location typical (fwd of firewall; view looking aft)

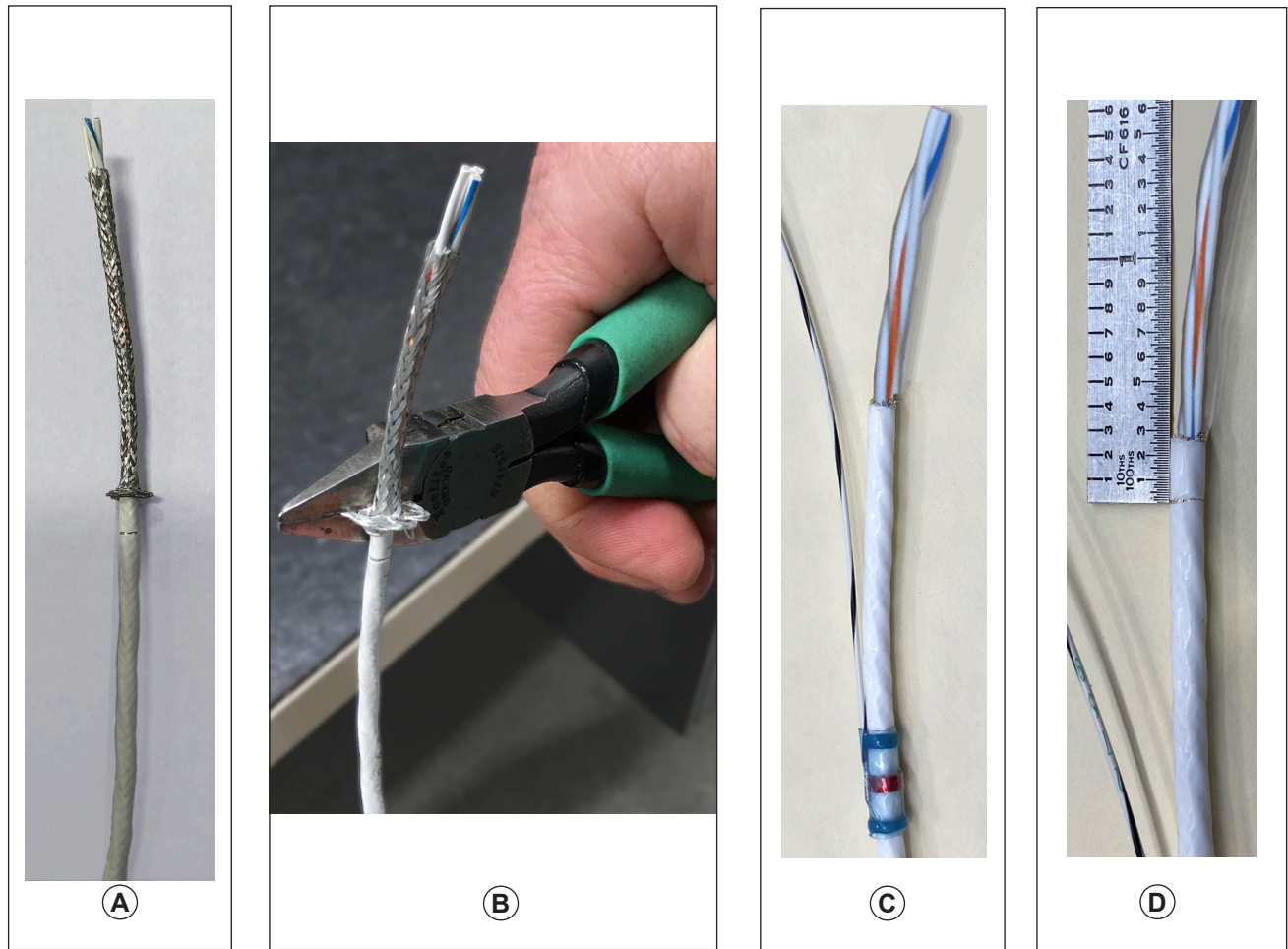

FIGURE 7 Removing outer jacket & braided shielding
(wiring shown is typical)



FIGURE 8 B267-3 terminator
(positioned for installation; wiring shown is typical)

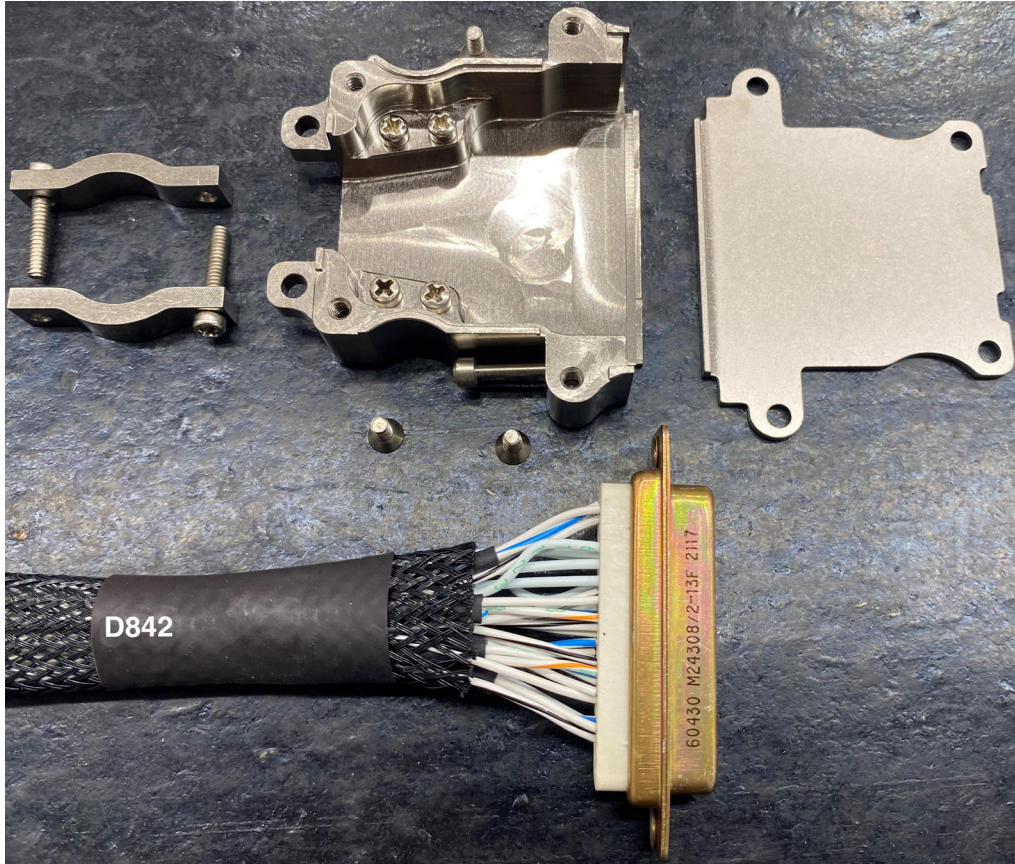
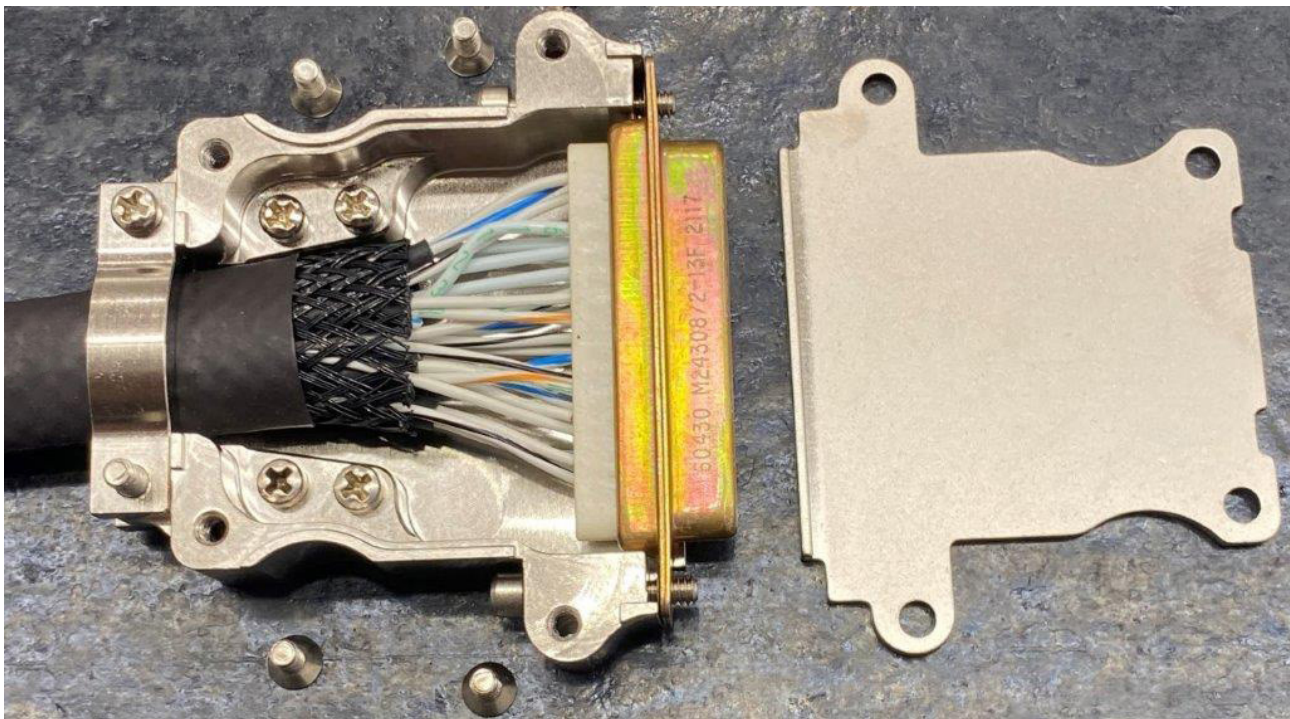

FIGURE 9 D842 controller connector



**FIGURE 10 Proper wire installation
(before installing cover)**

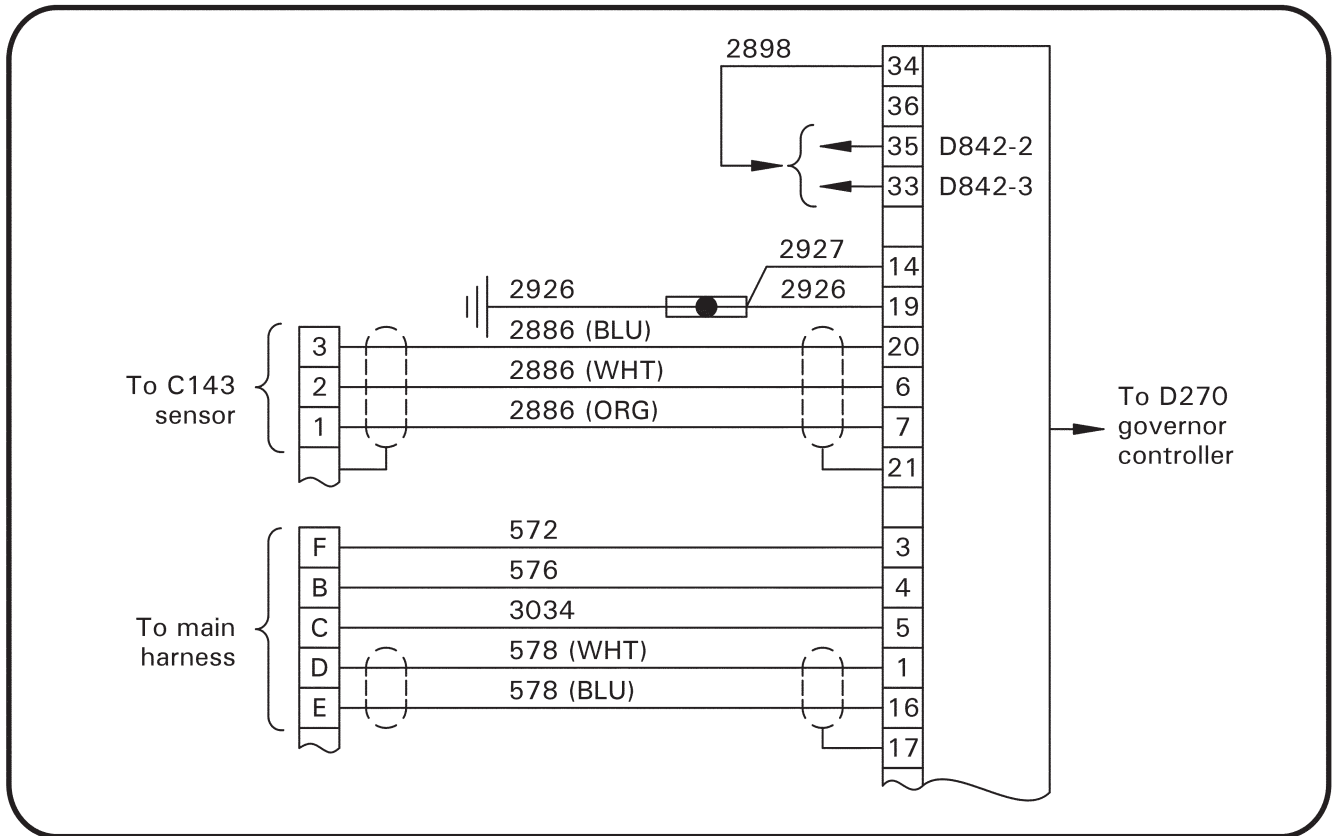
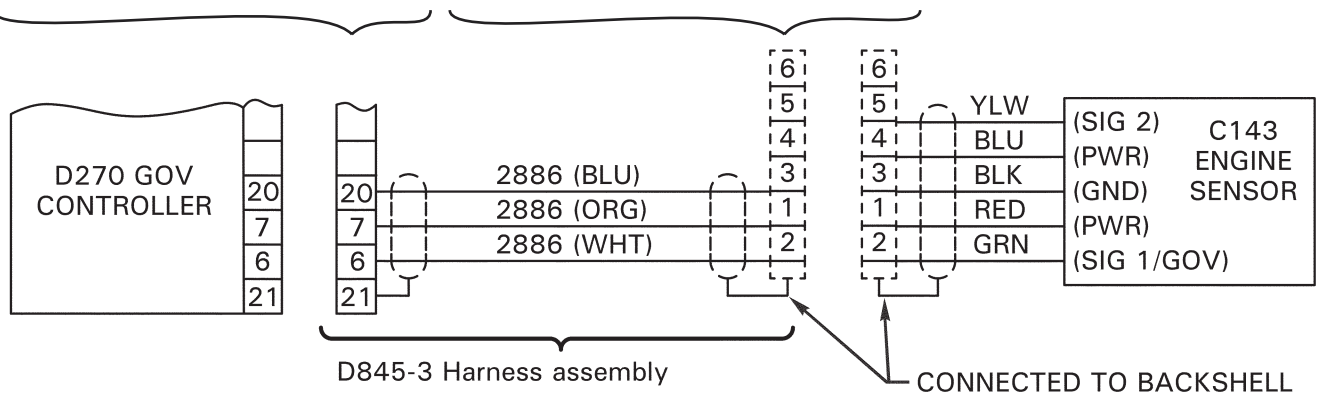

FIGURE 11 Schematic

CONDITIONS:		
1. Ohmmeter positive lead connected to ring terminal of D845-2 harness assembly tool 2. Governor controller connector disconnected 3. D845-3 harness and C143-6 sensor disconnected		
Insert pin of D845-2 harness assembly tool into socket at governor connector location:	Touch ohmmeter negative probe to:	Required result:
20	Location 3	CLOSED
20	Location 1	open
20	Location 2	open
20	Metal Backshell	open
7	Location 3	open
7	Location 1	CLOSED
7	Location 2	open
7	Metal Backshell	open
6	Location 3	open
6	Location 1	open
6	Location 2	CLOSED
6	Metal Backshell	open
21	Location 3	open
21	Location 1	open
21	Location 2	open
21	Metal Backshell	CLOSED



APPENDIX A