

ROBINSON HELICOPTER COMPANY

R44 ILLUSTRATED PARTS CATALOG

RTR 460 VOLUME II

Production Certificate Number 424WE

Type Certificate Number H11NM



Robinson Helicopter Company
2901 Airport Drive
Torrance, California 90505-6115
United States of America

Phone: (310) 539-0508
Fax: (310) 539-5198
Web: <https://robinsonheli.com>

OFFICE HOURS

Monday through Friday, 7:30 a.m. to 4:30 p.m., Pacific Time.
Lunch hour is 11:30 a.m. to 12:30 p.m.

HOLIDAYS

Please visit <https://robinsonheli.com> for a list of holidays and company shutdowns.

CUSTOMER SUPPORT AND SPARES ORDERS

Please visit <https://robinsonheli.com> for Customer Support contact information. Procure parts from any R44 Dealer or Service Center, or order directly from RHC Customer Service via email, fax, or phone.

PUBLICATIONS

Viewing RHC Maintenance Manuals (MMs) and Illustrated Parts Catalogs (IPCs) online at <https://robinsonheli.com> is recommended to ensure use of current data. Viewing MMs and IPCs offline via paper or digital download requires verification that the data is current. Refer to the online MM or IPC Revision Log for the list of current pages.

SUBSCRIPTION ORDER AND RENEWAL FORMS

Subscription order and renewal forms are located at <https://robinsonheli.com>.

WARRANTY INFORMATION

Helicopter and parts warranty information is located at <https://robinsonheli.com>.

CHAPTER LIST

	Introduction
Chapter 6	Dimensions and Descriptions
Chapter 8	Weight and Balance
Chapter 9	Ground Handling
Chapter 10	Parking and Storage
Chapter 11	Placards and Markings
Chapter 12	Servicing
Chapter 18	Track and Balance
Chapter 21	Environment Control
Chapter 22	Autopilot
Chapter 25	Furnishings
Chapter 28	Fuel System
Chapter 29	Hydraulics
Chapter 32	Landing Gear
Chapter 33	Lights
Chapter 52	Doors and Windows
Chapter 53	Fuselage
Chapter 62	Main Rotor
Chapter 63	Main Rotor Drive System
Chapter 64	Tail Rotor
Chapter 65	Tail Rotor Drive System
Chapter 67	Flight Controls
Chapter 71	Powerplant
Chapter 76	Engine Controls
Chapter 79	Engine Oil System
Chapter 90	Police Version
Chapter 92	E.N.G. Version
Chapter 94	Cadet Version
Chapter 95	Instrument System
Chapter 96	Electrical System
Chapter 97	Avionics
Chapter 99	Special Tools
Chapter 100	Revision Log

Intentionally Blank

TECHNICAL PUBLICATIONS

RECOMMENDED CHANGE REPORT

Please direct recommended changes to RHC Technical Publications via the email address listed below, by phone, or by submitting a duplicate of this completed form by fax or mail. Please include or have available the information detailed in this form.

Recommended changes may include but are not limited to general comments, corrections, omitted information, or clarification of instructions.

Please send recommendations to:

Email: techpubs@robinsonheli.com
Phone: (310) 539-0508
Fax: (310) 539-5198

Robinson Helicopter Company
Attention: Technical Publications
2901 Airport Drive
Torrance, CA 90505-6115
United States of America

Date:	_____	Publication:	_____
Name:	_____	Chapter:	_____
Company:	_____	Section:	_____
Helicopter Model:	_____	Page:	_____
Serial Number:	_____	Revision:	_____
Phone:	_____		
Email:	_____		

COMMENTS:

Intentionally Blank

CATALOG FEATURES

INTRODUCTION

The Illustrated Parts Catalog (IPC) is used in conjunction with the R44 Maintenance Manual (MM) to provide instructions for continued airworthiness. The IPC identifies parts, components, and detail parts that make up, and are required to support the R44 helicopter. RHC uses a modified Air Transport Association (ATA) chapter structure to organize the various systems of the R44 Helicopter.

The catalog features:

1. A chapter list
2. A table of contents located in the front of the catalog
3. A table of contents at the front of each chapter

PART DESIGNATION

Robinson parts are designated with a part number prefix "A", "B", "C", etc., followed by three digits and a dash number, such as A101-1. Robinson special tools are designated with a part number prefix "MT". For standard hardware items such as bolts, nuts, screws, etc., "AN", "MS", and "NAS" part numbers are used. When a rivet length is not specified, length must be determined by the installer. In some instances, vendor part numbers are also used.

PARTS AVAILABILITY

"X" indicates part is available as a separate spares item.

"O" indicates part is no longer available, or only available as part of a higher assembly.

CHANGE BARS

Change bars are located on the outside edge of the page, and indicate new or revised data. Change bars between lines indicate data was removed, and parts renumbered as required. Change bars on figure pages indicate changes to the figure somewhere across the page in the area of the change bar. A change bar encompassing the figure title and item 1 indicates the figure number changed. Change bars that are the full length of the page indicate all new data, usually a new figure and parts data.

ABBREVIATIONS

Assy – assembly	max – maximum	rev. – Revision
A/R – as required	min – minimum	RH – right hand
A.O.G. – Aircraft On Ground	MM – Maintenance Manual	RHC – Robinson Helicopter Company
Cont'd – continued	MR – main rotor	§ – Section
Incl – includes	OH/EXCH – Overhaul/Exchange	TR – Tail Rotor
LH – left hand	Ref – Part(s) "referenced" for clarity	TRDS – Tail Rotor Drive Shaft

ORDERING AND SHIPPING

All orders must include instructions for shipping.

WARRANTY

Helicopter and parts warranty information is located at www.robinsonheli.com.

RETURNS

All parts or components shipped to RHC must include a signed Component Return/Authorization Form. Return shipments must be prepaid.

No unused parts may be returned to RHC for credit if the parts show any indication whatsoever of use or damage. Parts returned within 30 days of purchase will be assessed a restocking fee. No parts may be returned after 30 days without prior RHC approval.

Continues

CATALOG FEATURES (Cont'd)REVISIONS

RHC Illustrated Parts Catalogs (IPCs) are available digitally at www.robinsonheli.com, under the Publications tab. Access to these publications does not require an account and is free of charge.

Viewing the IPC online is recommended to ensure use of current data.

Viewing the IPC offline via paper or digital download requires verification that the data is current. Refer to the online IPC Revision Log for the list of current pages.

Alphabetical and numerical indices have been deleted.

Sign up for free email notification of revisions to IPCs by sending an email to subscriptions@robinsonheli.com with "Subscribe email" in the subject line. Within the email, include name, email address, physical address, and helicopter model(s) of interest.

HOW TO USE THE ILLUSTRATED PARTS CATALOG

The IPCs are available digitally at www.robinsonheli.com, under the Publications tab. Files are available in PDF format. A keyword or part number search may help to locate applicable data. Open the chapter or full book PDF and launch a "search" or "find" window (Ctrl+F [PC] or Command+F [Mac]).

A search by system may be performed when the part number is not known. Go to the Chapter List on page iii, and determine the appropriate chapter. In the Chapter Table of Contents, determine from Figure titles where the item may logically appear. On the selected Figure illustration, locate the item and corresponding item number, and verify the item number by reading the description. Be sure to read any notes (indicated by asterisk) to ensure item is current for your aircraft.

PART INTERCHANGEABILITY

The following parts are interchangeable. Unless noted otherwise, whenever one part is referred to in this catalog, its substitute part is also permitted.

<u>PART:</u>	<u>INTERCHANGEABLE WITH:</u>
110-__ Telatemp	F110-__ Telatemp
22K1-048 Cap nut	B340-10 Cap nut
22K1-82 Cap nut	B340-4 Cap nut
354601 Fuse block	D262-1 Fuse block
354602 Fuse block	D262-2 Fuse block
4509 & Q4509 Lamp	B196-26 Lamp
4591 Lamp	B196-27 Lamp
511TS1-3 Switch	B300-4 Switch
94830A030 Nut	21FKF-518 Nut
AN_ and MS_ part	AS_ part or A880 part numbers
AN340 Nut	MS35649 Nut per NASM35649 except AN340B8 Nut
AN340B8 Nut	B301-8 Nut
AN345 Nut	MS35650 Nut per NASM35650
AN364 Nut	MS21083 Nut per NASM21083
AN507 Screw	MS24693 Screw per NASM24693
AN509 Screw	MS24694 Screw per NASM24694
AN515 Screw	MS35206 Screw per NASM35206
AN515C Screw	MS51957 Screw
AN515UB6R6 Screw	B567-25 Screw
AN515UB6R10 Screw	B567-28 Screw
AN515UB8R10 Screw	B567-43 Screw
AN515UB8R12 Screw	B567-44 Screw
AN515UB8R20 Screw	MS35214-47 Screw per NASM35214
AN525 & AN526 Screw	MS27039C Screw per NASM27039, or B526-6 or -8 Screw and B527-08 Washer per R44 MM § 16-61. Except where noted.
AN814 & MS24391 Plug	AS5169 Plug
AN815 & MS24392 Union	AS5174 Union
AN818-__D Nut	AN818-__W Nut
AN819 & MS20819 Sleeve	AS5176 Sleeve
AN822 & MS20822 Elbow	AS5195 Elbow
AN823 & MS20823 Elbow	AS5196 Elbow
AN825 & MS20825 Tee	AS5197 Tee
AN826 & MS20826 Tee	AS5198 Tee
AN894 & MS24398 Bushing	AS5173 Bushing
AN900 Gasket	MS35769 Gasket per AS35769
AN924 & MS24400 Nut	AS5178 Nut
AN931 Grommet	MS35489 Grommet
AN935 Lockwasher	B332-__ Lockwasher, dash number per MS35338
AN936 Lockwasher	MS35335 Lockwasher
AN960-4L Washer	NAS1149FN416P Washer
AN960-4 Washer	NAS1149FN432P Washer
AN960-6L Washer	NAS1149FN616P Washer
AN960-6 Washer	NAS1149FN632P Washer
AN960-8L Washer	NAS1149FN816P Washer
AN960-8 Washer	NAS1149FN832P Washer

Continues

PART INTERCHANGEABILITY (Cont'd)

<u>PART:</u>	<u>INTERCHANGEABLE WITH:</u>
AN960-10L Washer	NAS1149F0332P Washer
AN960-10 Washer	NAS1149F0363P Washer
AN960-416L Washer	NAS1149F0432P Washer
AN960-416 Washer	NAS1149F0463P Washer
AN960-516L Washer	NAS1149F0532P Washer
AN960-516 Washer	NAS1149F0563P Washer
AN960-616L Washer	NAS1149F0632P Washer
AN960-616 Washer	NAS1149F0663P Washer
AN960-816L Washer	NAS1149F0832P Washer
AN960-816 Washer	NAS1149F0863P Washer
AN960-1016L Washer	NAS1149F1032P Washer
AN960-1016 Washer	NAS1149F1063P Washer
AN960PD8L Washer	NAS1149DN816J Washer
AN960PD416L Washer	NAS1149D0416J Washer
AN960PD516L Washer	NAS1149D0516J Washer
AN960PD616L Washer	NAS1149D0616J Washer
AVDEL 016__ Rivet	B204__ Rivet
B0500-022-S Washer	A478-2 Washer
B1000-035-S Washer	A478-3 Washer
B1000-043-S Washer	A478-4 Washer
B270-6 Sealant	A701-11 Tape
CCR244SS-3-02 Rivet	B204-5 Rivet
MS26574-__ Circuit breaker	B297-__ Circuit breaker, except B297-25 and B297-120
MS3320-20 Circuit breaker	B297-120 Circuit breaker
LW-18959-150-25 Clamp	B444-1 Clamp
LW-18959-163-25 Clamp	B444-2 Clamp
LW-18959-175-25 Clamp	B444-3 Clamp
MS20604ML4W1 Rivet	MS20604M4W1 Rivet per NASM20604
MS21042L3 thru L6 Nut	D210-3 thru -6 Nut*
MS21209__ Insert	MS21209__ L or NAS1130__ Insert
MS21919__ Clamp	AS21919__ Clamp
MS24665 CAD plated steel cotter pin	MS24665 CRES cotter pin per NASM24665
MS27039C080__ Screw	B526-6 or -8 Screw and B527-08 Washer per R44 MM § 16-61. Except where noted.
MS27151-__ Palnut	B330-__ Palnut
NAS1067 Nutplate	MS21086 Nutplate per NASM21086
NAS1068A__ Nutplate	MS21075L__ E Nutplate per NASM21075
NAS1291-04 thru -08 Nut	MS21042 Nut per NASM21042
NAS1291-3 thru -10 Nut	D210-3 thru -10 Nut*
NAS1303 thru NAS1320 Bolt, except 1307 Bolt	NAS6603 thru NAS6620** Bolt, except 6607 Bolt
NAS1919B0__ SO__ Rivet	NAS9301B-__ -0__ Rivet
NAS1921B0__ SO__ Rivet	NAS9302B-__ -0__ Rivet
NAS428-__ -__ Bolt	NAS428-__ A__ Bolt
NAS487 Instrument nut	MS33737 Instrument nut per NASM33737
NAS679A__ Nut	NAS1291-__ Nut
NAS679C__ M Nut	NAS1291C__ M Nut

* One-way interchangeability, only D210 nut shall be used for listed sizes.

** The following bolts must be NAS1300 series only: NAS1304-17 and NAS1305-35.

Continues

PART INTERCHANGEABILITY (Cont'd)

<u>PART:</u>	<u>INTERCHANGEABLE WITH:</u>
NAS696 Nutplate	MS21071 Nutplate per NASM21071
NAS697 Nutplate	MS21069 & MS21070 Nutplate per NASM21069 & NASM21070
NAS698 Nutplate	MS21073 Nutplate per NASM21073

A880 FLARED TUBE COMPONENTS

A. Nuts – Flare

Dash Numbers	Allowable Part Numbers	Material REF	Tube OD REF
-102	AN818-2D, AN818-2W, AS5175W02	AL	1/8-inch
-103	AN818-3D, AN818-3W, AS5175W03	AL	3/16-inch
-104	AN818-4D, AN818-4W, AS5175W04	AL	1/4-inch
-105	AN818-5D, AN818-5W, AS5175W05	AL	5/16-inch
-106	AN818-6D, AN818-6W, AS5175W06	AL	3/8-inch
-108	AN818-8D, AN818-8W, AS5175W08	AL	1/2-inch
-110	AN818-10D, AN818-10W, AS5175W10	AL	5/8-inch
-202	AN818-2J, AS5175J02	CRES	1/8-inch
-203	AN818-3J, AS5175J03	CRES	3/16-inch
-204	AN818-4J, AS5175J04	CRES	1/4-inch
-205	AN818-5J, AS5175J05	CRES	5/16-inch
-206	AN818-6J, AS5175J06	CRES	3/8-inch
-208	AN818-8J, AS5175J08	CRES	1/2-inch
-210	AN818-10J, AS5175J10	CRES	5/8-inch

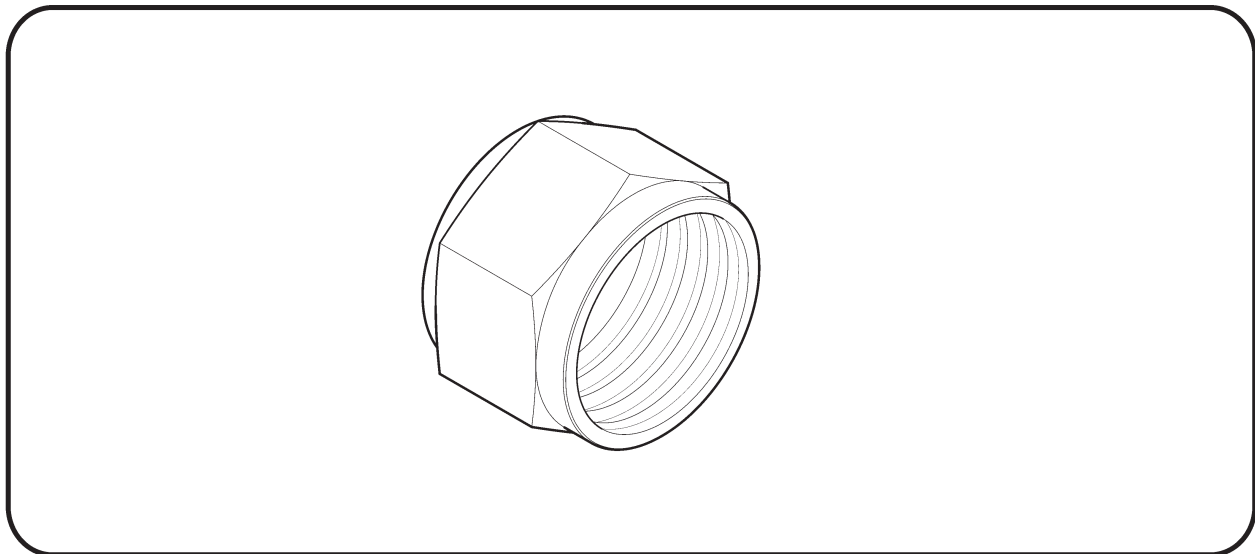

Continues

A880 FLARED TUBE COMPONENTS (Cont'd)

B. Sleeves

Dash Numbers	Allowable Part Numbers	Material REF	Tube OD REF
-302	MS20819-2D, AS3220D02, AS3220W02	AL	1/8-inch
-303	MS20819-3D, AS3220D03, AS3220W03	AL	3/16-inch
-304	MS20819-4D, AS3220D04, AS3220W04	AL	1/4-inch
-305	MS20819-5D, AS3220D05, AS3220W05	AL	5/16-inch
-306	MS20819-6D, AS3220D06, AS3220W06	AL	3/8-inch
-308	MS20819-8D, AS3220D08, AS3220W08	AL	1/2-inch
-310	MS20819-10D, AS3220D10, AS3220W10	AL	5/8-inch
-402	MS20819-2J, AS5176J02	CRES	1/8-inch
-403	MS20819-3J, AS5176J03	CRES	3/16-inch
-404	MS20819-4J, AS5176J04	CRES	1/4-inch
-405	MS20819-5J, AS5176J05	CRES	5/16-inch
-406	MS20819-6J, AS5176J06	CRES	3/8-inch
-408	MS20819-8J, AS5176J08	CRES	1/2-inch
-410	MS20819-10J, AS5176J10	CRES	5/8-inch

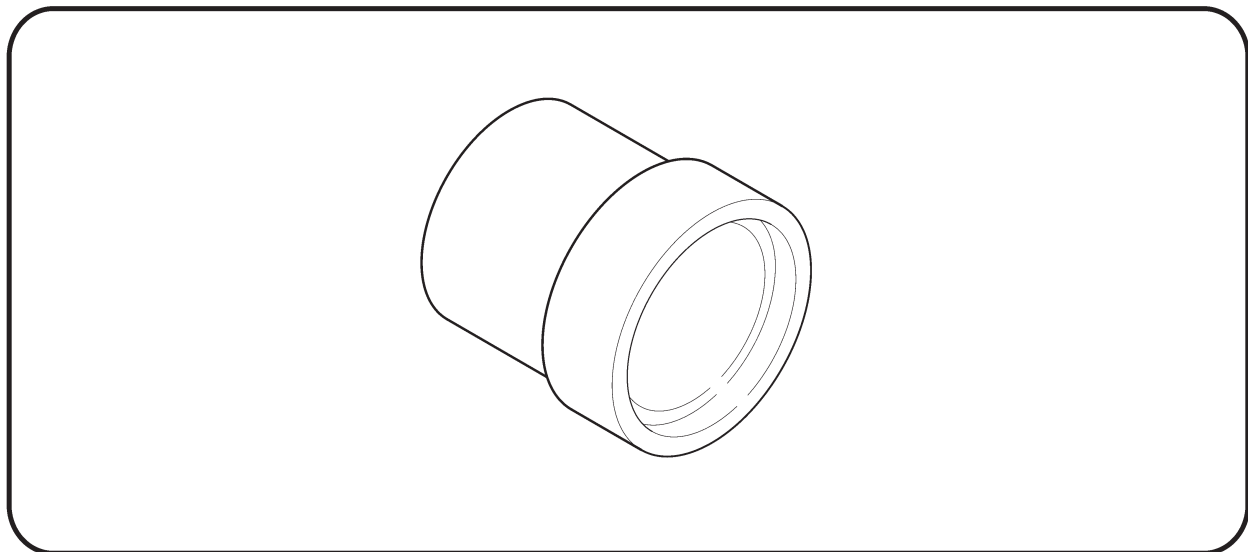

Continues

A880 FLARED TUBE COMPONENTS (Cont'd)

C. Adapters – NPT to Flare

Dash Numbers	Allowable Part Numbers	Material REF	Tube OD REF
-502	AN816-2D, AS5194D0202	AL	1/8-inch
-503	AN816-3D, AS5194D0302	AL	3/16-inch
-504	AN816-4D, AS5194D0402	AL	1/4-inch
-505	AN816-5D, AS5194D0502	AL	5/16-inch
-506	AN816-6D, AS5194D0604	AL	3/8-inch
-508	AN816-8D, AS5194D0806	AL	1/2-inch
-510	AN816-10D, AS5194D1008	AL	5/8-inch
-532	AN816-2J, AS5194J0202	CRES	1/8-inch
-533	AN816-3J, AS5194J0302	CRES	3/16-inch
-534	AN816-4J, AS5194J0402	CRES	1/4-inch
-535	AN816-5J, AS5194J0502	CRES	5/16-inch
-536	AN816-6J, AS5194J0604	CRES	3/8-inch
-538	AN816-8J, AS5194J0806	CRES	1/2-inch
-540	AN816-10J, AS5194J1008	CRES	5/8-inch
-562	AN816-2, AS5194-0202	STL	1/8-inch
-563	AN816-3, AS5194-0302	STL	3/16-inch
-564	AN816-4, AS5194-0402	STL	1/4-inch
-565	AN816-5, AS5194-0502	STL	5/16-inch
-566	AN816-6, AS5194-0604	STL	3/8-inch
-568	AN816-8, AS5194-0806	STL	1/2-inch
-570	AN816-10, AS5194-1008	STL	5/8-inch

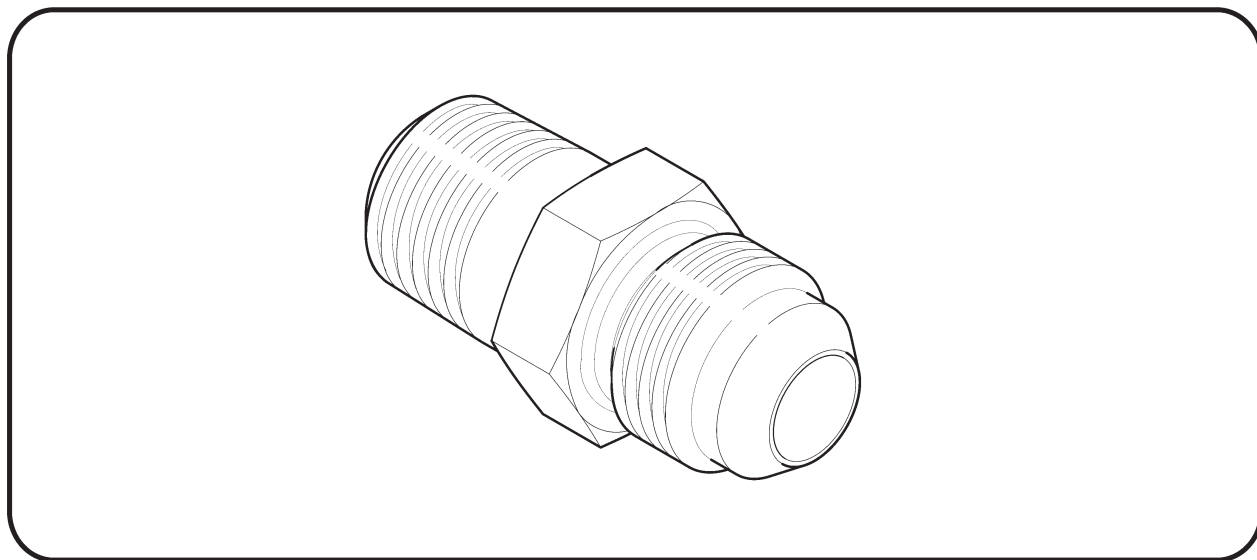

Continues

A880 FLARED TUBE COMPONENTS (Cont'd)

D. Elbows – 90°, NPT to Flare

Dash Numbers	Allowable Part Numbers	Material REF	Tube OD REF
-602	AN822-2D, MS20822-2D, AS5195W0202	AL	1/8-inch
-603	AN822-3D, MS20822-3D, AS5195W0302	AL	3/16-inch
-604	AN822-4D, MS20822-4D, AS5195W0402	AL	1/4-inch
-605	AN822-5D, MS20822-5D, AS5195W0502	AL	5/16-inch
-606	AN822-6D, MS20822-6D, AS5195W0604	AL	3/8-inch
-608	AN822-8D, MS20822-8D, AS5195W0806	AL	1/2-inch
-610	AN822-10D, MS20822-10D, AS5195W1008	AL	5/8-inch
-632	AN822-2J, MS20822-2J, AS5195J0202	CRES	1/8-inch
-633	AN822-3J, MS20822-3J, AS5195J0302	CRES	3/16-inch
-634	AN822-4J, MS20822-4J, AS5195J0402	CRES	1/4-inch
-635	AN822-5J, MS20822-5J, AS5195J0502	CRES	5/16-inch
-636	AN822-6J, MS20822-6J, AS5195J0604	CRES	3/8-inch
-638	AN822-8J, MS20822-8J, AS5195J0806	CRES	1/2-inch
-640	AN822-10J, MS20822-10J, AS5195J1008	CRES	5/8-inch
-662	AN822-2, MS20822-2, AS5195-0202	STL	1/8-inch
-663	AN822-3, MS20822-3, AS5195-0302	STL	3/16-inch
-664	AN822-4, MS20822-4, AS5195-0402	STL	1/4-inch
-665	AN822-5, MS20822-5, AS5195-0502	STL	5/16-inch
-666	AN822-6, MS20822-6, AS5195-0604	STL	3/8-inch
-668	AN822-8, MS20822-8, AS5195-0806	STL	1/2-inch
-670	AN822-10, MS20822-10, AS5195-1008	STL	5/8-inch

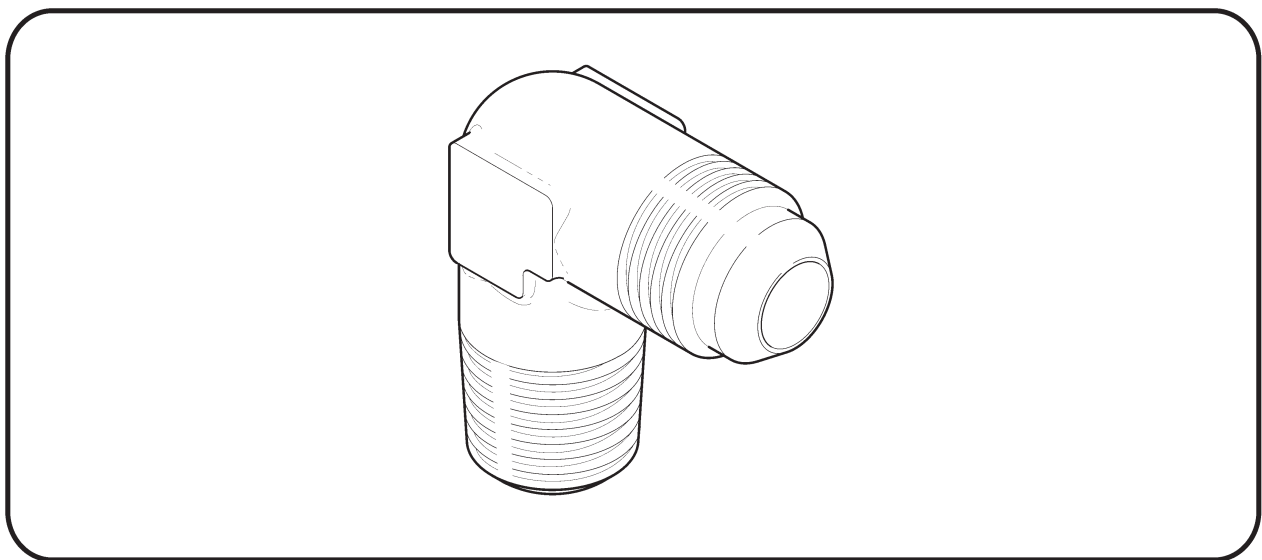

Continues

A880 FLARED TUBE COMPONENTS (Cont'd)

E. Elbows – 45°, NPT to Flare

Dash Numbers	Allowable Part Numbers	Material REF	Tube OD REF
-702	AN823-2D, MS20823-2D, AS5196W0202	AL	1/8-inch
-703	AN823-3D, MS20823-3D, AS5196W0302	AL	3/16-inch
-704	AN823-4D, MS20823-4D, AS5196W0402	AL	1/4-inch
-705	AN823-5D, MS20823-5D, AS5196W0502	AL	5/16-inch
-706	AN823-6D, MS20823-6D, AS5196W0604	AL	3/8-inch
-708	AN823-8D, MS20823-8D, AS5196W0806	AL	1/2-inch
-710	AN823-10D, MS20823-10D, AS5196W1008	AL	5/8-inch
-732	AN823-2J, MS20823-2J, AS5196J0202	CRES	1/8-inch
-733	AN823-3J, MS20823-3J, AS5196J0302	CRES	3/16-inch
-734	AN823-4J, MS20823-4J, AS5196J0402	CRES	1/4-inch
-735	AN823-5J, MS20823-5J, AS5196J0502	CRES	5/16-inch
-736	AN823-6J, MS20823-6J, AS5196J0604	CRES	3/8-inch
-738	AN823-8J, MS20823-8J, AS5196J0806	CRES	1/2-inch
-740	AN823-10J, MS20823-10J, AS5196J1008	CRES	5/8-inch
-762	AN823-2, MS20823-2, AS5196-0202	STL	1/8-inch
-763	AN823-3, MS20823-3, AS5196-0302	STL	3/16-inch
-764	AN823-4, MS20823-4, AS5196-0402	STL	1/4-inch
-765	AN823-5, MS20823-5, AS5196-0502	STL	5/16-inch
-766	AN823-6, MS20823-6, AS5196-0604	STL	3/8-inch
-768	AN823-8, MS20823-8, AS5196-0806	STL	1/2-inch
-770	AN823-10, MS20823-10, AS5196-1008	STL	5/8-inch

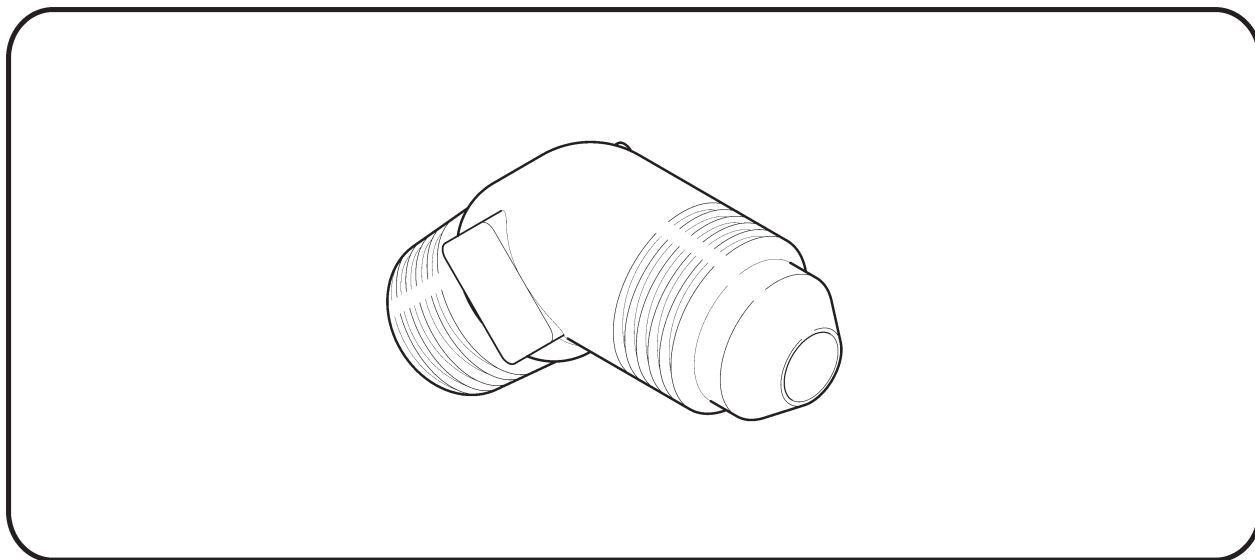

Continues

A880 FLARED TUBE COMPONENTS (Cont'd)

F. Elbows – 90°, Bulkhead Flare to Flare

Dash Numbers	Allowable Part Numbers	Material REF	Tube OD REF
-802	AN833-2D, AS1038D0202, AS1038W0202	AL	1/8-inch
-803	AN833-3D, AS1038D0303, AS1038W0303	AL	3/16-inch
-804	AN833-4D, AS1038D0404, AS1038W0404	AL	1/4-inch
-805	AN833-5D, AS1038D0505, AS1038W0505	AL	5/16-inch
-806	AN833-6D, AS1038D0606, AS1038W0606	AL	3/8-inch
-808	AN833-8D, AS1038D0808, AS1038W0808	AL	1/2-inch
-810	AN833-10D, AS1038D1010, AS1038W1010	AL	5/8-inch
-832	AN833-2J, AS1038J0202	CRES	1/8-inch
-833	AN833-3J, AS1038J0303	CRES	3/16-inch
-834	AN833-4J, AS1038J0404	CRES	1/4-inch
-835	AN833-5J, AS1038J0505	CRES	5/16-inch
-836	AN833-6J, AS1038J0606	CRES	3/8-inch
-838	AN833-8J, AS1038J0808	CRES	1/2-inch
-840	AN833-10J, AS1038J1010	CRES	5/8-inch
-862	AN833-2, AS1038-0202	STL	1/8-inch
-863	AN833-3, AS1038-0303	STL	3/16-inch
-864	AN833-4, AS1038-0404	STL	1/4-inch
-865	AN833-5, AS1038-0505	STL	5/16-inch
-866	AN833-6, AS1038-0606	STL	3/8-inch
-868	AN833-8, AS1038-0808	STL	1/2-inch
-870	AN833-10, AS1038-1010	STL	5/8-inch

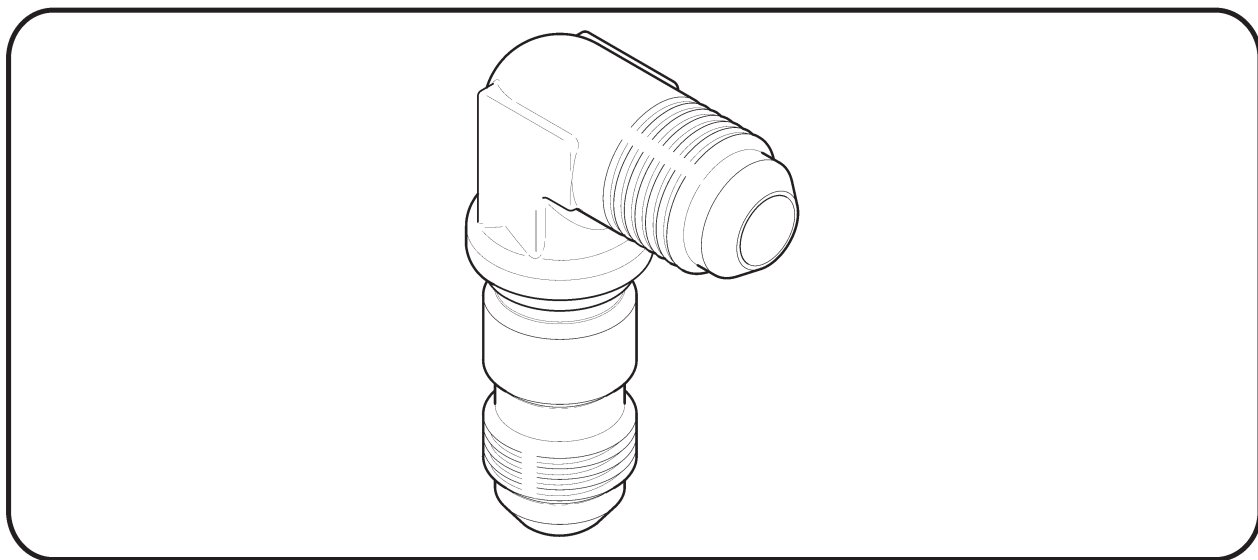

Continues

A880 FLARED TUBE COMPONENTS (Cont'd)

G. Unions – Flare to Flare

Dash Numbers	Allowable Part Numbers	Material REF	Tube OD REF
-902	AN815-2D, AS5174D0202, AS5174W0202	AL	1/8-inch
-903	AN815-3D, AS5174D0303, AS5174W0303	AL	3/16-inch
-904	AN815-4D, AS5174D0404, AS5174W0404	AL	1/4-inch
-905	AN815-5D, AS5174D0505, AS5174W0505	AL	5/16-inch
-906	AN815-6D, AS5174D0606, AS5174W0606	AL	3/8-inch
-908	AN815-8D, AS5174D0808, AS5174W0808	AL	1/2-inch
-910	AN815-10D, AS5174D1010, AS5174W1010	AL	5/8-inch
-932	AN815-2J, AS5174J0202	CRES	1/8-inch
-933	AN815-3J, AS5174J0303	CRES	3/16-inch
-934	AN815-4J, AS5174J0404	CRES	1/4-inch
-935	AN815-5J, AS5174J0505	CRES	5/16-inch
-936	AN815-6J, AS5174J0606	CRES	3/8-inch
-938	AN815-8J, AS5174J0808	CRES	1/2-inch
-940	AN815-10J, AS5174J1010	CRES	5/8-inch
-962	AN815-2, AS5174-0202	STL	1/8-inch
-963	AN815-3, AS5174-0303	STL	3/16-inch
-964	AN815-4, AS5174-0404	STL	1/4-inch
-965	AN815-5, AS5174-0505	STL	5/16-inch
-966	AN815-6, AS5174-0606	STL	3/8-inch
-968	AN815-8, AS5174-0808	STL	1/2-inch
-970	AN815-10, AS5174-1010	STL	5/8-inch

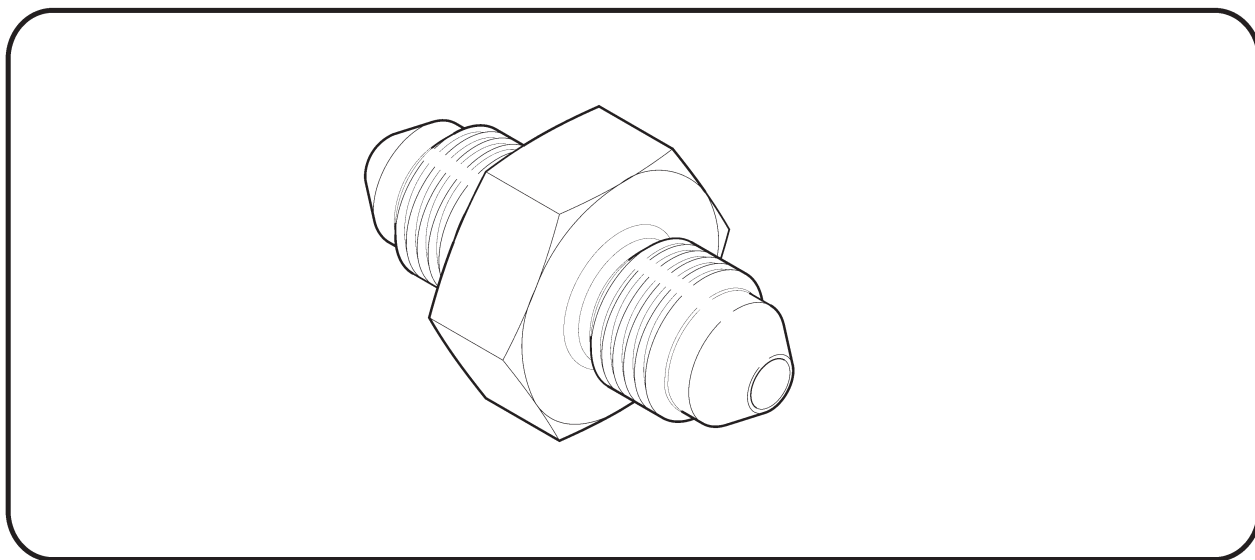

Continues

A880 FLARED TUBE COMPONENTS (Cont'd)

H. Nuts – Hex

Dash Numbers	Allowable Part Numbers	Material REF	Tube OD REF
-1002	AN924-2D, AN924-2W, AS5178W02	AL	1/8-inch
-1003	AN924-3D, AN924-3W, AS5178W03	AL	3/16-inch
-1004	AN924-4D, AN924-4W, AS5178W04	AL	1/4-inch
-1005	AN924-5D, AN924-5W, AS5178W05	AL	5/16-inch
-1006	AN924-6D, AN924-6W, AS5178W06	AL	3/8-inch
-1008	AN924-8D, AN924-8W, AS5178W08	AL	1/2-inch
-1010	AN924-10D, AN924-10W, AS5178W10	AL	5/8-inch
-1032	AN924-2J, AS5178J02	CRES	1/8-inch
-1033	AN924-3J, AS5178J03	CRES	3/16-inch
-1034	AN924-4J, AS5178J04	CRES	1/4-inch
-1035	AN924-5J, AS5178J05	CRES	5/16-inch
-1036	AN924-6J, AS5178J06	CRES	3/8-inch
-1038	AN924-8J, AS5178J08	CRES	1/2-inch
-1040	AN924-10J, AS5178J10	CRES	5/8-inch
-1062	AN924-2, AS5178-02	STL	1/8-inch
-1063	AN924-3, AS5178-03	STL	3/16-inch
-1064	AN924-4, AS5178-04	STL	1/4-inch
-1065	AN924-5, AS5178-05	STL	5/16-inch
-1066	AN924-6, AS5178-06	STL	3/8-inch
-1068	AN924-8, AS5178-08	STL	1/2-inch
-1070	AN924-10, AS5178-10	STL	5/8-inch

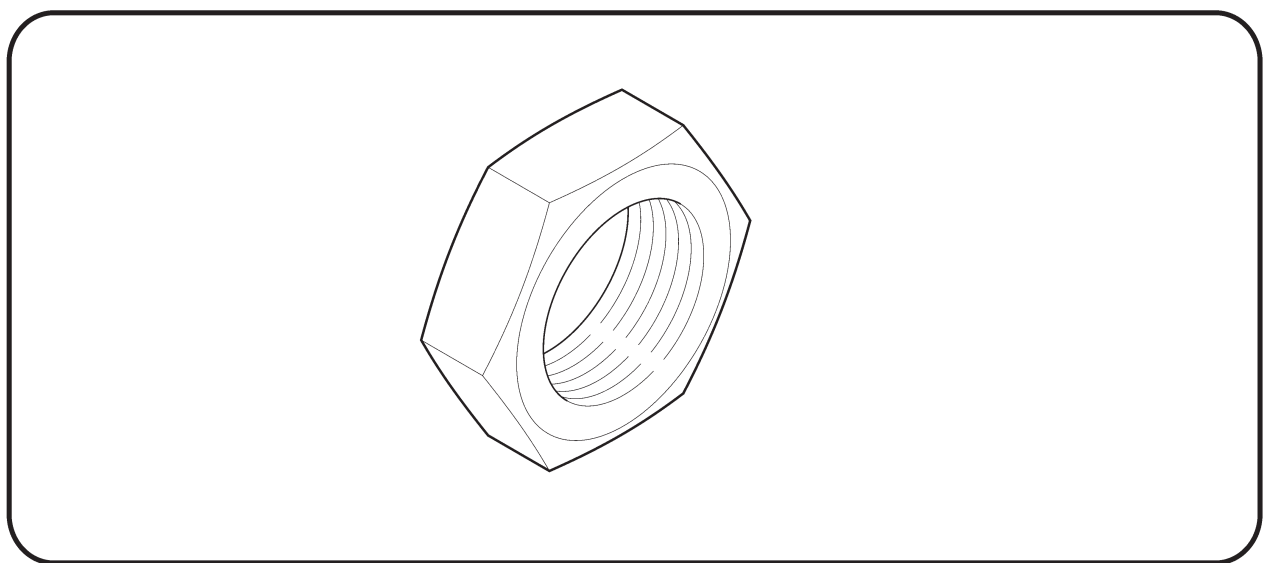

Continues

A880 FLARED TUBE COMPONENTS (Cont'd)

I. Tees – NPT to Flare

Dash Numbers	Allowable Part Numbers	Material REF	Tube OD REF
-1102	AN826-2D, MS20826-2D, AS5198W020202	AL	1/8-inch
-1103	AN826-3D, MS20826-3D, AS5198W030203	AL	3/16-inch
-1104	AN826-4D, MS20826-4D, AS5198W040204	AL	1/4-inch
-1105	AN826-5D, MS20826-5D, AS5198W050205	AL	5/16-inch
-1106	AN826-6D, MS20826-6D, AS5198W060406	AL	3/8-inch
-1108	AN826-8D, MS20826-8D, AS5198W080608	AL	1/2-inch
-1110	AN826-10D, MS20826-10D, AS5198W100810	AL	5/8-inch
-1132	AN826-2J, MS20826-2J, AS5198J020202	CRES	1/8-inch
-1133	AN826-3J, MS20826-3J, AS5198J030203	CRES	3/16-inch
-1134	AN826-4J, MS20826-4J, AS5198J040204	CRES	1/4-inch
-1135	AN826-5J, MS20826-5J, AS5198J050205	CRES	5/16-inch
-1136	AN826-6J, MS20826-6J, AS5198J060406	CRES	3/8-inch
-1138	AN826-8J, MS20826-8J, AS5198J080608	CRES	1/2-inch
-1140	AN826-10J, MS20826-10J, AS5198J100810	CRES	5/8-inch
-1162	AN826-2, MS20826-2, AS5198-020202	STL	1/8-inch
-1163	AN826-3, MS20826-3, AS5198-030203	STL	3/16-inch
-1164	AN826-4, MS20826-4, AS5198-040204	STL	1/4-inch
-1165	AN826-5, MS20826-5, AS5198-050205	STL	5/16-inch
-1166	AN826-6, MS20826-6, AS5198-060406	STL	3/8-inch
-1168	AN826-8, MS20826-8, AS5198-080608	STL	1/2-inch
-1170	AN826-10, MS20826-10, AS5198-100810	STL	5/8-inch

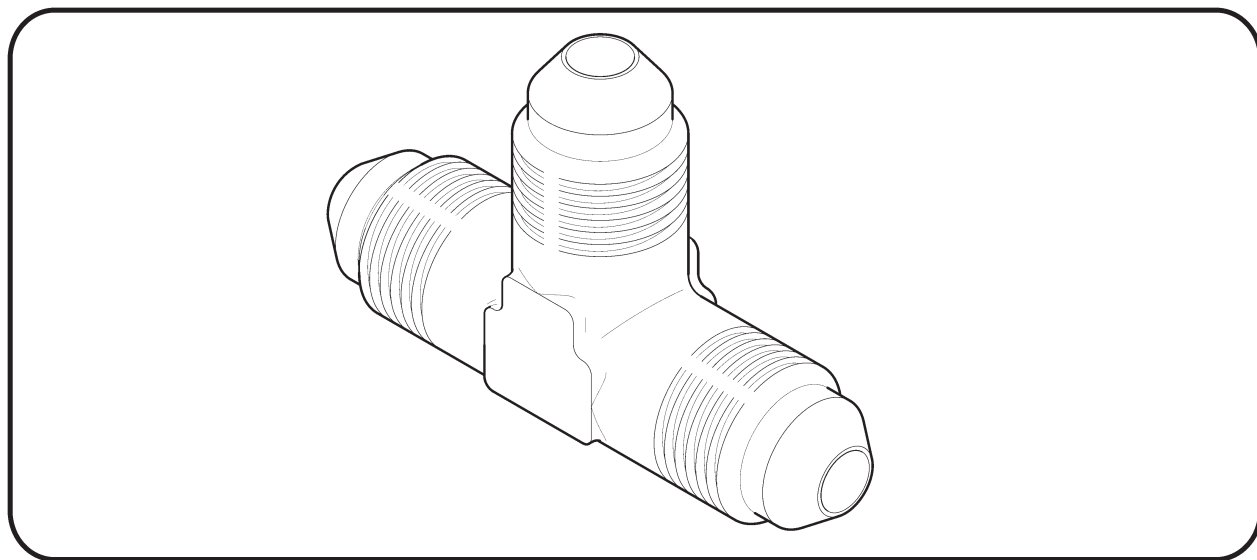

Continues

A880 FLARED TUBE COMPONENTS (Cont'd)

J. Plugs without Holes

Dash Numbers	Allowable Part Numbers	Material REF	Tube OD REF
-1202	AN814-2D, AN814-2W, AS5169D02, AS5169W02	AL	1/8-inch
-1203	AN814-3D, AN814-3W, AS5169D03, AS5169W03	AL	3/16-inch
-1204	AN814-4D, AN814-4W, AS5169D04, AS5169W04	AL	1/4-inch
-1205	AN814-5D, AN814-5W, AS5169D05, AS5169W05	AL	5/16-inch
-1206	AN814-6D, AN814-6W, AS5169D06, AS5169W06	AL	3/8-inch
-1208	AN814-8D, AN814-8W, AS5169D08, AS5169W08	AL	1/2-inch
-1210	AN814-10D, AN814-10W, AS5169D10, AS5169W10	AL	5/8-inch
-1232	AN814-2J, AS5169J02	CRES	1/8-inch
-1233	AN814-3J, AS5169J03	CRES	3/16-inch
-1234	AN814-4J, AS5169J04	CRES	1/4-inch
-1235	AN814-5J, AS5169J05	CRES	5/16-inch
-1236	AN814-6J, AS5169J06	CRES	3/8-inch
-1238	AN814-8J, AS5169J08	CRES	1/2-inch
-1240	AN814-10J, AS5169J10	CRES	5/8-inch
-1262	AN814-2, AS5169-02	STL	1/8-inch
-1263	AN814-3, AS5169-03	STL	3/16-inch
-1264	AN814-4, AS5169-04	STL	1/4-inch
-1265	AN814-5, AS5169-05	STL	5/16-inch
-1266	AN814-6, AS5169-06	STL	3/8-inch
-1268	AN814-8, AS5169-08	STL	1/2-inch
-1270	AN814-10, AS5169-10	STL	5/8-inch

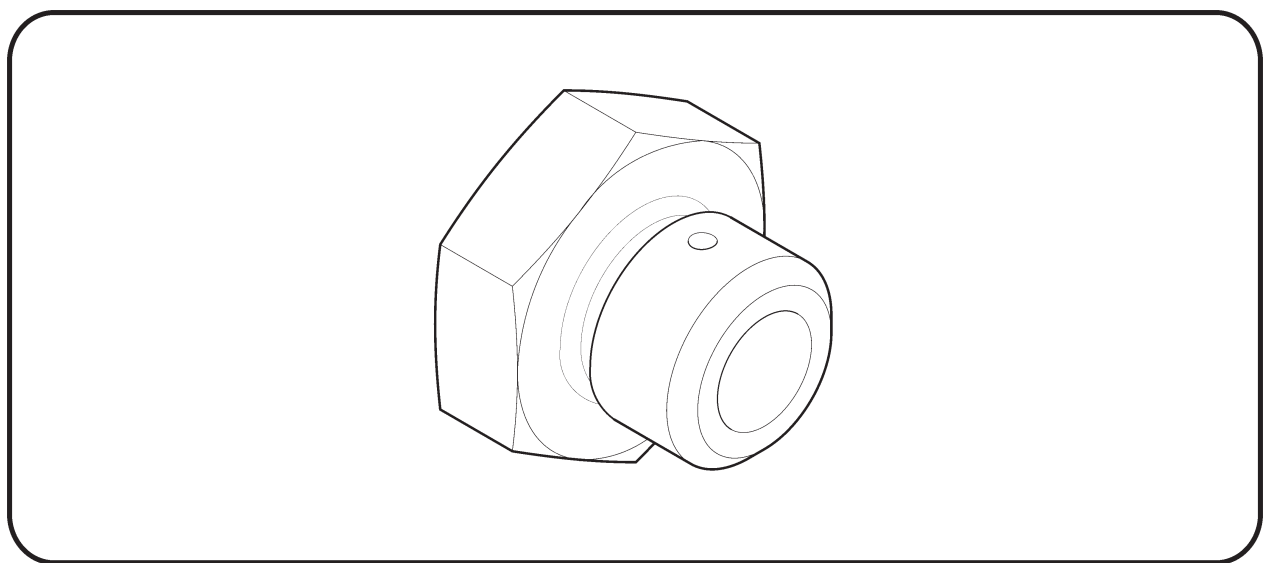

Continues

A880 FLARED TUBE COMPONENTS (Cont'd)

K. Plugs with Holes

Dash Numbers	Allowable Part Numbers	Material REF	Tube OD REF
-1302	AN814-2DL, AN814-2WL, AS5169D02L, AS5169W02L	AL	1/8-inch
-1303	AN814-3DL, AN814-3WL, AS5169D03L, AS5169W03L	AL	3/16-inch
-1304	AN814-4DL, AN814-4 WL, AS5169D04L, AS5169W04L	AL	1/4-inch
-1305	AN814-5DL, AN814-5WL, AS5169D05L, AS5169W05L	AL	5/16-inch
-1306	AN814-6DL, AN814-6WL, AS5169D06L, AS5169W06L	AL	3/8-inch
-1308	AN814-8DL, AN814-8WL, AS5169D08L, AS5169W08L	AL	1/2-inch
-1310	AN814-10DL, AN814-10WL, AS5169D10L, AS5169W10L	AL	5/8-inch
-1332	AN814-2JL, AS5169J02L	CRES	1/8-inch
-1333	AN814-3JL, AS5169J03L	CRES	3/16-inch
-1334	AN814-4JL, AS5169J04L	CRES	1/4-inch
-1335	AN814-5JL, AS5169J05L	CRES	5/16-inch
-1336	AN814-6JL, AS5169J06L	CRES	3/8-inch
-1338	AN814-8JL, AS5169J08L	CRES	1/2-inch
-1340	AN814-10JL, AS5169J10L	CRES	5/8-inch
-1362	AN814-2L, AS5169-02L	STL	1/8-inch
-1363	AN814-3L, AS5169-03L	STL	3/16-inch
-1364	AN814-4L, AS5169-04L	STL	1/4-inch
-1365	AN814-5L, AS5169-05L	STL	5/16-inch
-1366	AN814-6L, AS5169-06L	STL	3/8-inch
-1368	AN814-8L, AS5169-08L	STL	1/2-inch
-1370	AN814-10L, AS5169-10L	STL	5/8-inch

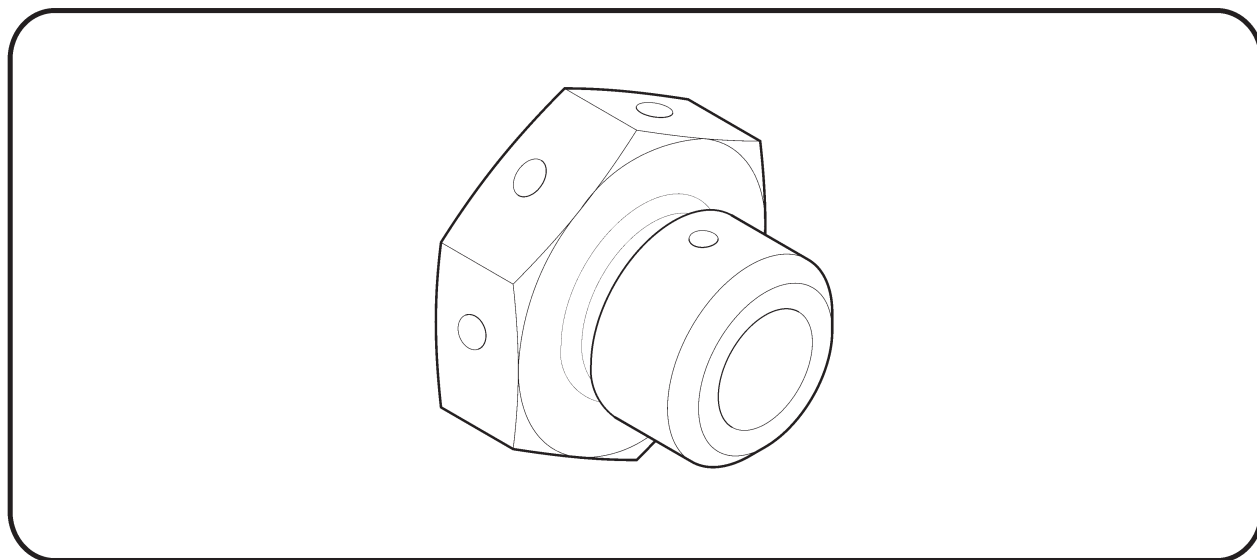

CHAPTER 6

DIMENSIONS AND DESCRIPTIONS

<i>Figure</i>	<i>Title</i>	<i>Page</i>
6-1	Access Panels – Chin	6.0
6-3	Access Panels – Pedals and Floor	6.2
6-5	Access Panels – Forward Cabin	6.4
6-7	Access Panels – Mid Cabin	6.6
6-11	Access Panels – Aft Cabin	6.10
6-13	Access Panels – Belly	6.12
6-15	NAV Antenna Installation	6.14
6-17	Radar Altimeter Antennas	6.16
6-19	ADF/Marker Beacon Antennas	6.18
6-21	FM/DME Antennas	6.20
6-23	Aft Belly Antennas	6.22
6-25	Aft Belly Antennas	6.24
6-27	Kannad ELT Antenna Installation	6.26
6-29	Tailcone Antenna Cable Connectors	6.28
6-31	Upper Tailcone Antennas	6.30
6-35	Upper Tailcone Antennas	6.34
6-37	Lower Tailcone Antennas	6.36

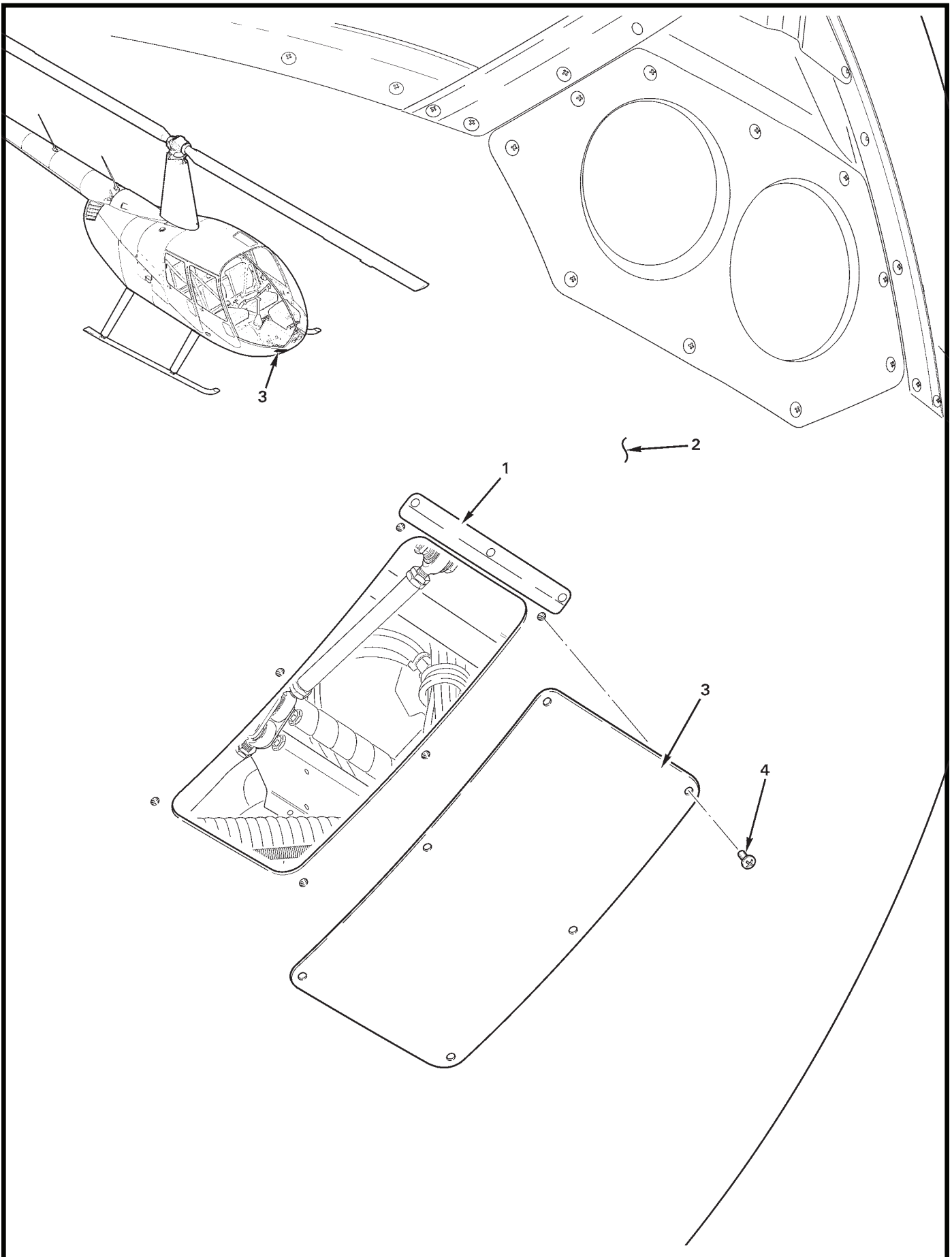

FIGURE AND INDEX NUMBER	PART NUMBER	DESCRIPTION	PARTS AVAIL	QTY PER ASSY
ACCESS PANELS - CHIN				
6-1-1	C795-2	Shingle (Ref)		
2	C272-1	Chin (Ref)		
3	C795-1	Cover (inspection)	X	1
4	MS27039C0806	Screw	X	6
NOTES				

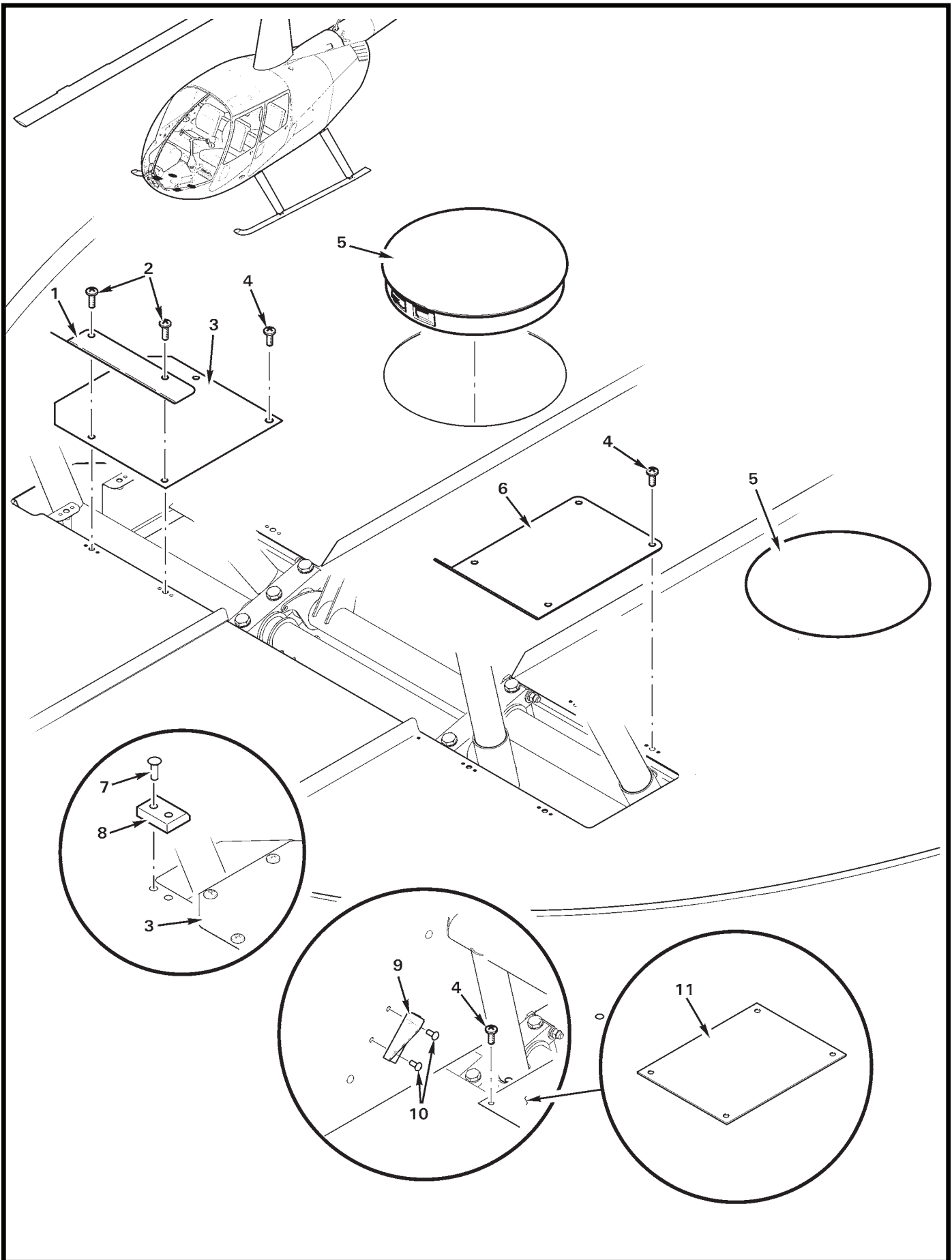

FIGURE AND INDEX NUMBER	PART NUMBER	DESCRIPTION	PARTS AVAIL	QTY PER ASSY
ACCESS PANELS - PEDALS AND FLOOR				
6-3-1	B189-2	Deflector	X	1
2	MS27039C0807	Screw	X	2
3	A412-2	Cover (RH)	X	1
4	MS27039C0806	Screw	X	6
5	2451	Hole Plug	X	2
6	B189-4	Deflector	X	1
7	MS20470AD5*	Rivet	X	2
8	A793-1*	Stop	X	1
9	A366-2*	Stop (LH and RH)	X	2
10	MS20470AD4*	Rivet	X	4
11	A412-1*	Cover (LH)	X	1

NOTES * Installed on earlier R44s.

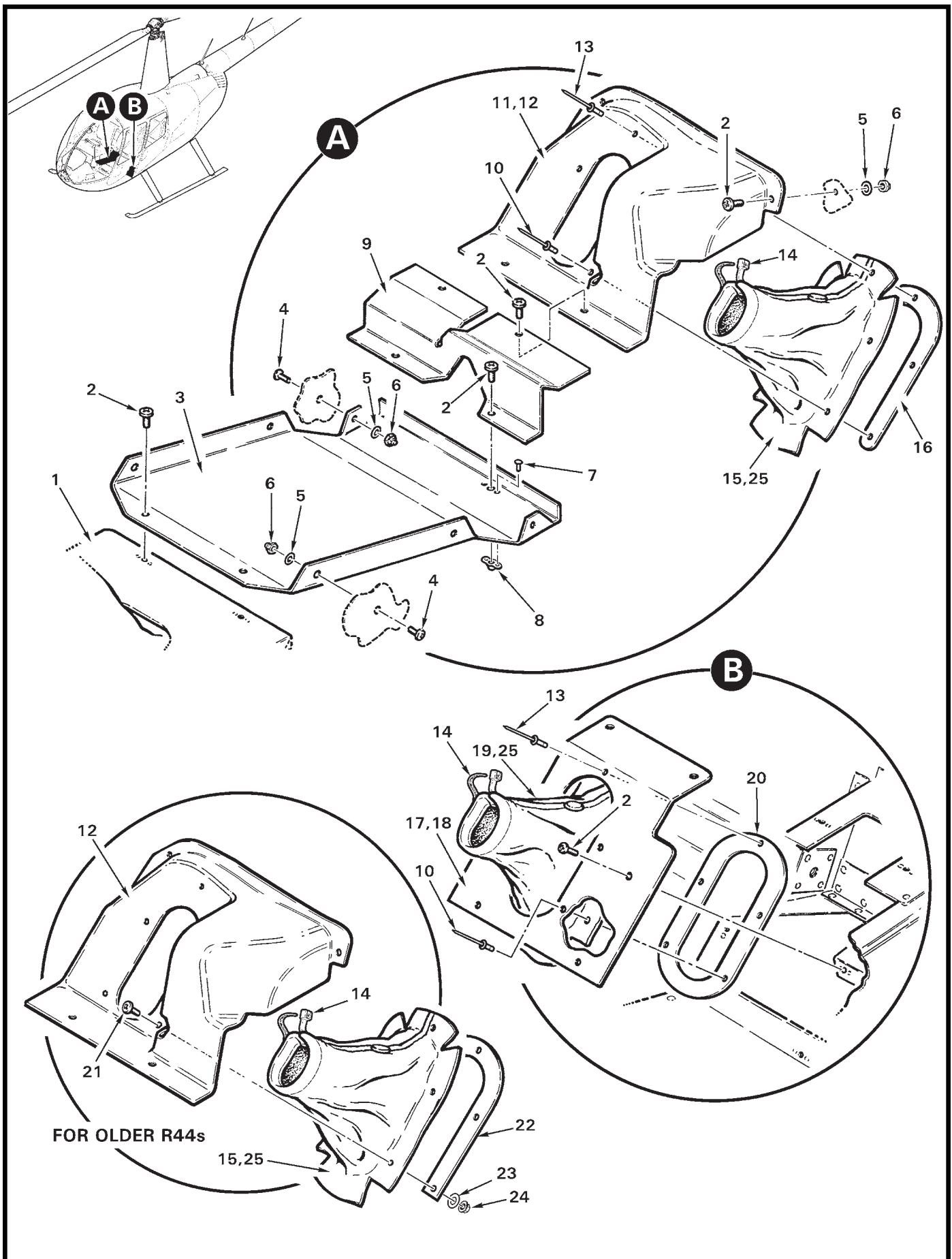

FIGURE AND INDEX NUMBER	PART NUMBER	DESCRIPTION	PARTS AVAIL	QTY PER ASSY
ACCESS PANELS - FORWARD CABIN				
6-5-1	C444	Cover - Cyclic (Ref, see Figure 67-1)		
2	MS27039C0806	Screw	X	13
3	C445-1	Cover Assembly (Incl items 7 and 8)	X	1
4	MS27039C0805	Screw	X	6
5	NAS1149FN816P	Washer	X	8
6	B340-4	Nut	X	8
7	MS20426AD3	Rivet	X	4
8	MS21069L08K	Nutplate	X	2
9	C445-3	Cover (standard installation)	X	1
	D672-1	Cover (Ref; pop-out float installation only, see Figure 32-11) . .		
10	B204-1	Rivet (blind)	X	4
11	C680-5	Cover Assembly (Incl items 10, 12, 13, 15, 16, and 25)	X	1
12	C398-1	Cover	X	1
13	B204-2	Rivet (blind)	X	1
14	MS3367-5-0	Ty-Rap	X	1
15	A678-3	Boot Assembly (Incl item 14)	O	1
16	C680-6	Ring	X	1
17	C680-1	Cover Assembly (Incl items 10, 13, 18 thru 20, 22, and 25) . . .	X	1
18	C680-2	Cover (Ref)	O	1
19	A678-1	Boot Assembly (Incl item 14)	O	1
20	C680-3	Ring (Ref)	O	1
21	MS27039C0806*	Screw	X	5
22	A680-2	Ring	X	1
23	NAS1149FN816P*	Washer	X	5
24	MS21042L08	Nut	X	5
25	B270-8	Adhesive	X	A/R

NOTES * For earlier R44s at this location.

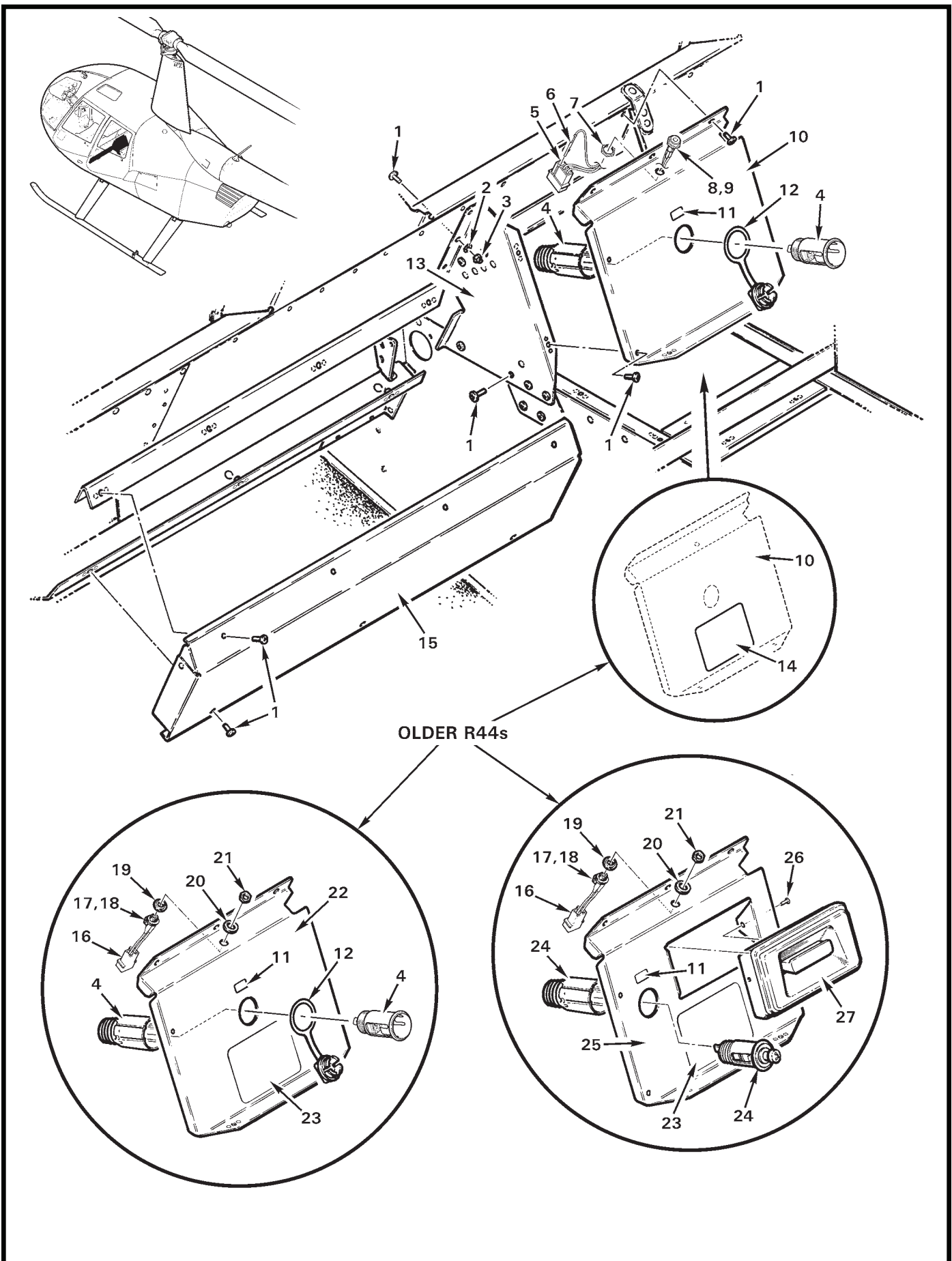

FIGURE AND INDEX NUMBER	PART NUMBER	DESCRIPTION	PARTS AVAIL	QTY PER ASSY
ACCESS PANELS - MID CABIN				
6-7-1	MS27039C0806	Screw	X	21
2	NAS1149FN816P	Washer	X	3
3	B340-4	Nut	X	3
4	D692-4	Socket	X	1
5	B263-14	Housing	X	1
6	B263-1	Pin	X	3
7	—	Nut	O	1
8	161-7300-EX	Jack (Incl item 7)	O	1
9	C049-14	Harness Assembly (stereo external audio input; includes items 6, 8, wires, and heat shrink, assembled)	X	1
10	C054-2	Cover Assembly - Mid Tunnel (Incl items 4, 5, 9, and 12)	X	1
11	C654-22	Decal - "28V"	X	A/R
	C654-29	Decal - "14V"	X	A/R
12	D692-3	Cover	X	1
13	C356-1	Brace Assembly	X	1
14	A654-84	Decal - "DANGER" (as required for earlier R44s)	X	1
15	C461-1	Cover	X	1
16	B263-12	Housing	X	1
	B263-1	Pin	X	2
17	41	Jack (Incl items 19 thru 21)	X	1
18	C049-6	Harness Assembly (external audio input, earlier R44s; includes items 16 and 17, wires, and heat shrink, assembled)	X	1
19	11-474-C	Washer	X	1
20	11-444-C	Washer	X	1
21	—	Nut	O	1
22	C054-1	Cover Assembly - Mid Tunnel (Earlier R44s, C054-1 revision "F". Includes items 4, 12, 18, and 23.)	X	1
23	A643-84	Decal - "DANGER"	X	1
24	D692-1	Lighter (14-volt ships)	X	1
	208392*	Lighter (28-volt ships; Ref, supersedes D692-2. No longer available.)		
25	C054-1	Cover Assembly - Mid Tunnel (Earlier R44s, C054-1 revision "E" and earlier. No longer available.)		

NOTES * Casco Products Corporation part no.

Continues

FIGURE AND INDEX NUMBER	PART NUMBER	DESCRIPTION	PARTS AVAIL	QTY PER ASSY
ACCESS PANELS - MID CABIN (Cont'd)				
6-7-26 27	MS20470AD3 S1052-1	Rivet Ashtray (Ref, no longer available)	X	2
NOTES				

Intentionally Blank

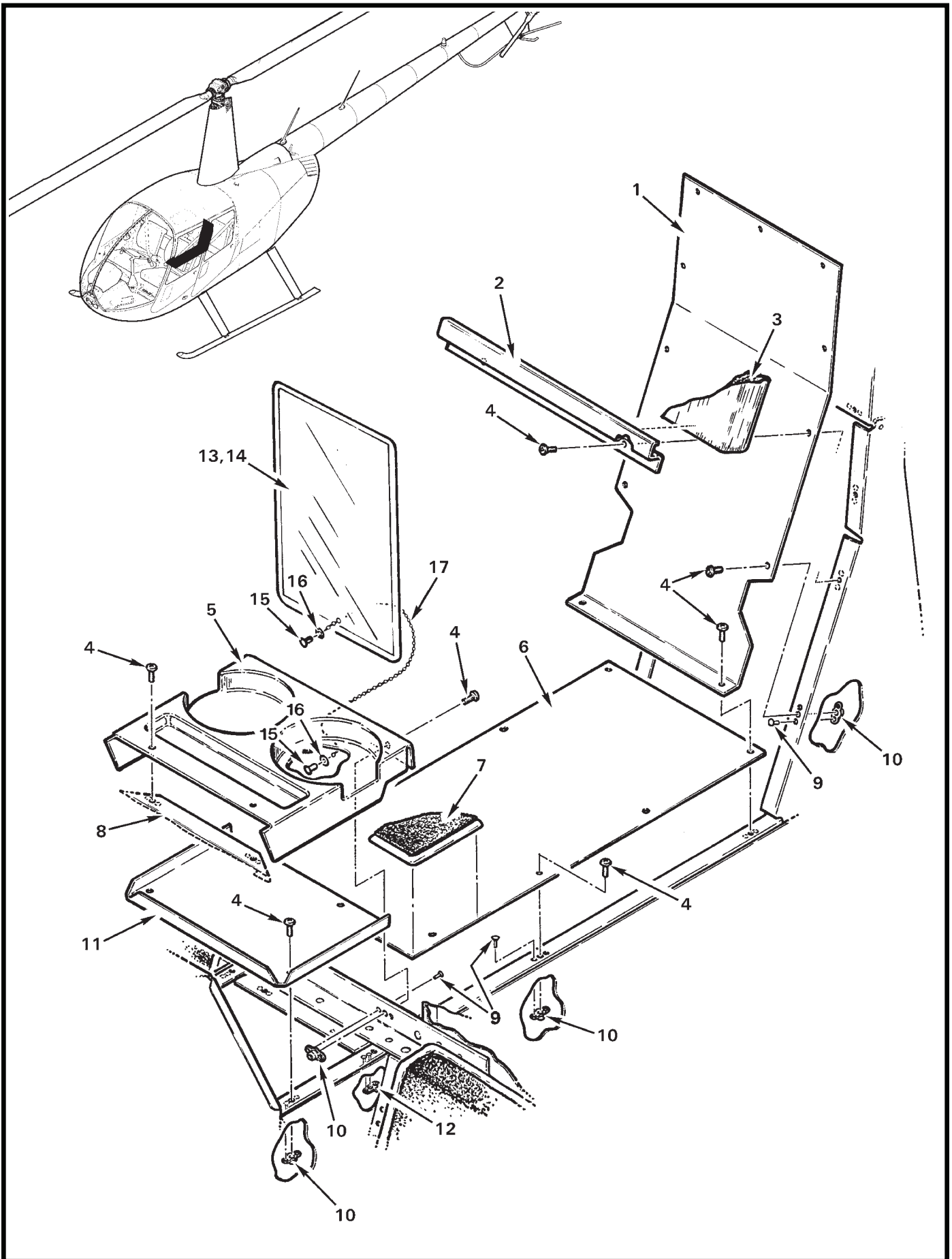

FIGURE AND INDEX NUMBER	PART NUMBER	DESCRIPTION	PARTS AVAIL	QTY PER ASSY
ACCESS PANELS - AFT CABIN				
6-11-1	C474-1	Cover	X	1
2	C474-3	Trim	X	1
3	C003-2 or -18	Insulation (Ref, see Figure 25-23)		
4	MS27039C0806	Screw	X	26
5	C464-1	Tray	X	1
6	C474-2	Cover	X	1
7	C469-8	Carpet Assembly (Ref, see Figure 25-19)		
8	C054	Cover Assembly (Ref, see Figure 6-7)		
9	MS20426AD3	Rivet (flush head)	X	50
10	MS21069L08	Nutplate	X	23
11	C463-1	Cover	X	1
12	MS21071L08	Nutplate	X	2
13	MT598-2*	Passenger Safety Card Assembly (Incl items 14 thru 17)	X	1
14	MT598-1	Card - Passenger Safety (laminated; card only)	X	1
15	3606T141	Retainer Sleeve	X	2
16	NAS620-5	Washer	X	2
17	3606T11	Bead Chain (9.00 inch length)	X	A/R

NOTES * Optional.

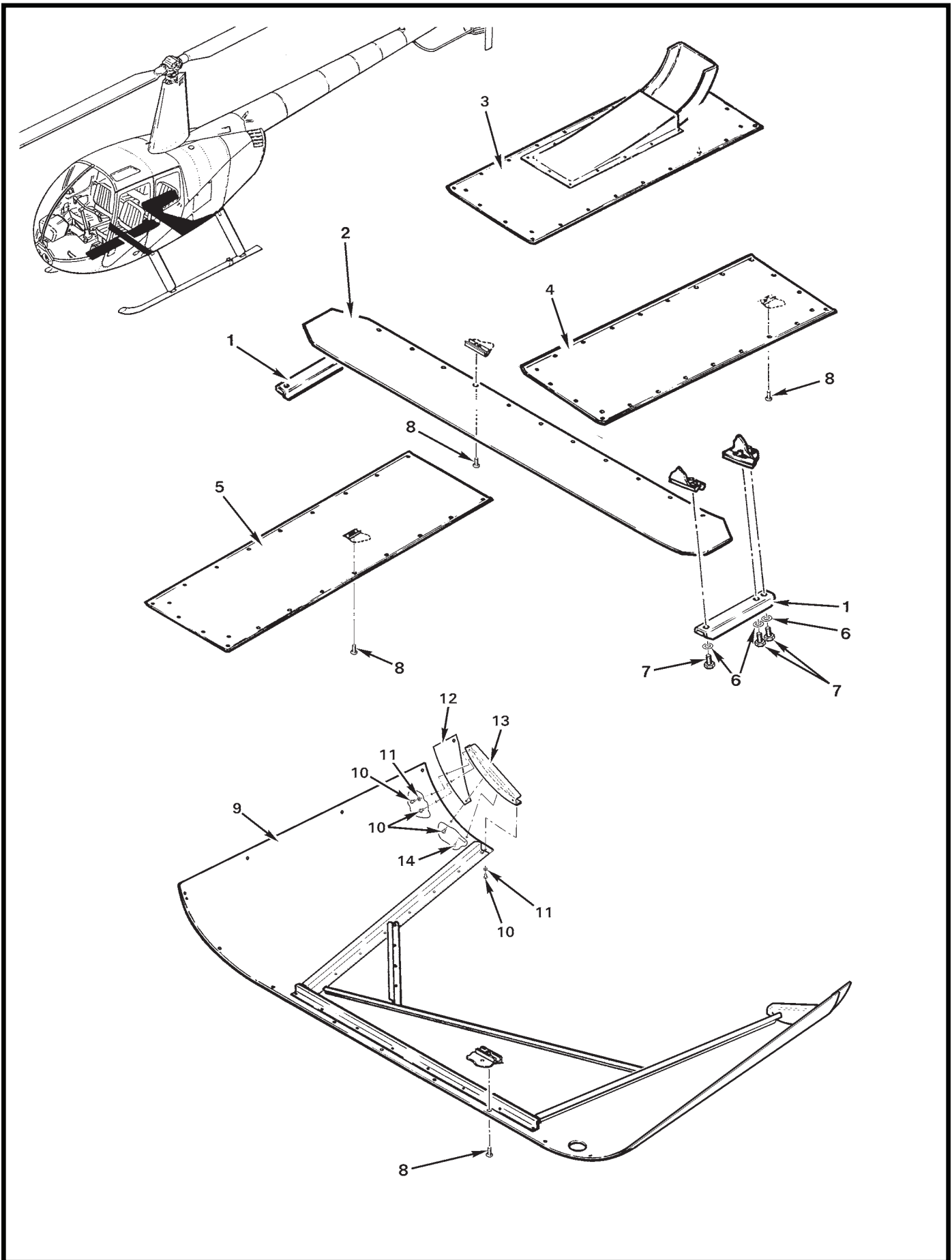

FIGURE AND INDEX NUMBER	PART NUMBER	DESCRIPTION	PARTS AVAIL	QTY PER ASSY
ACCESS PANELS – BELLY				
6-13-1	C388-3	Channel	X	2
2	C475-5	Cover	X	1
3	C794-3	Panel Assembly (with air inlet)	X	1
4	C794-2	Panel Assembly	X	1
5	C794-1	Panel	X	1
6	NAS1149F0332P	Washer	X	6
7	NAS6603-4	Bolt	X	6
8	MS27039C0806	Screw	X	68
9	D041-1	Cowling Assembly – Belly	X	1
10	MS20470AD4	Rivet	X	8
11	NAS620-5	Washer	X	4
12	D312-5	Doubler (RH and LH)	X	2
13	D312-6	Rib (RH and LH)	X	2
14	MS20470AD3	Rivet	X	2

NOTES

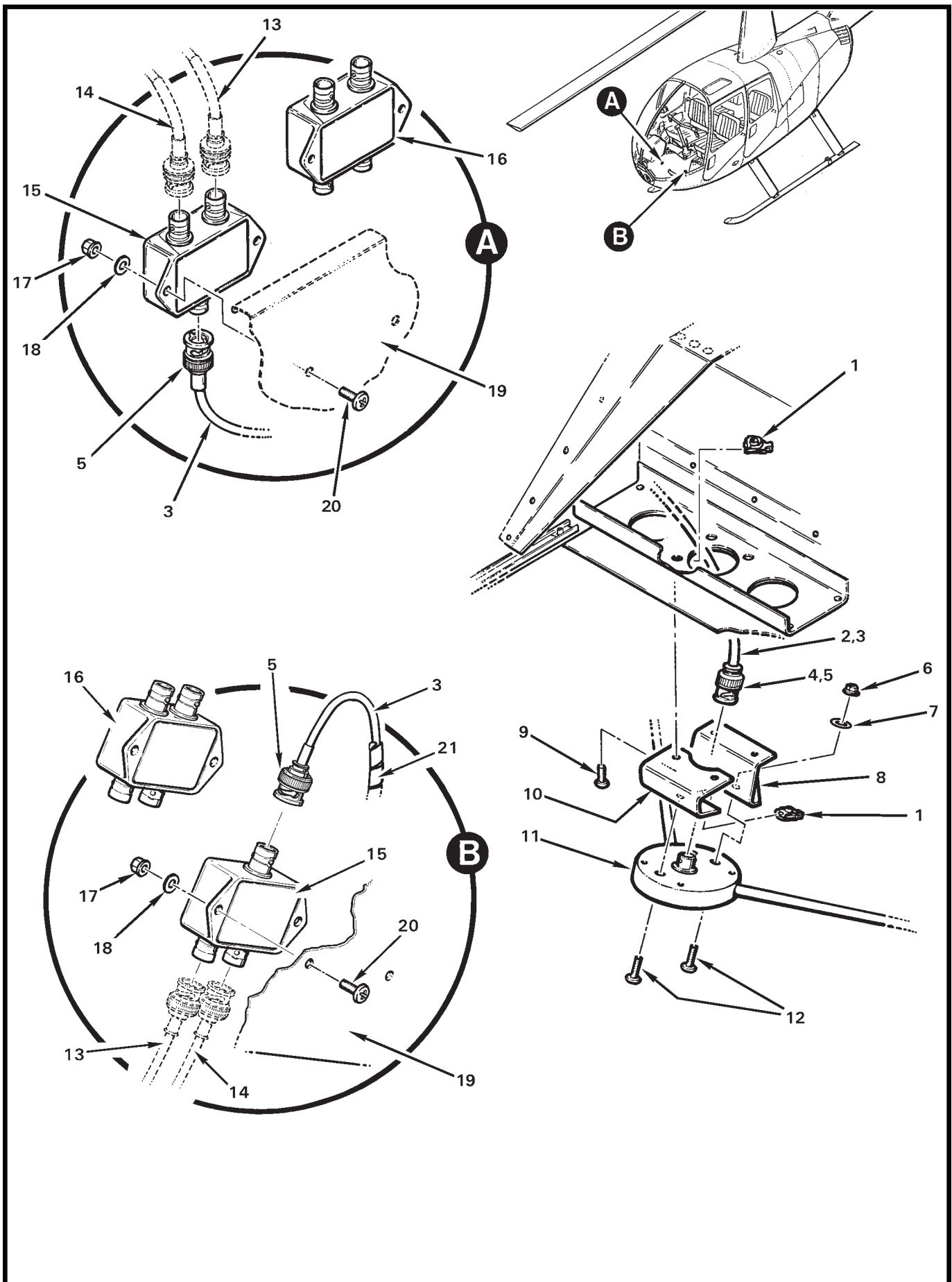

FIGURE AND INDEX NUMBER	PART NUMBER	DESCRIPTION	PARTS AVAIL	QTY PER ASSY
NAV ANTENNA INSTALLATION				
6-15-1	B162-4	Clipnut	X	4
2	C850-240	Cable (antenna to radio)	X	1
3	C850-1844	Cable (antenna to item 15 or 16)	X	1
4	5225395-1	Plug (use with item 2)	X	1
5	5225395-6	Plug (use with item 3)	X	A/R
6	MS21042L3	Nut	X	2
7	NAS1149F0332P	Washer	X	2
8	B159-2	Bracket	X	1
9	MS27039C1-07	Screw	X	4
10	B159-1	Bracket	X	1
11	CI 259E*	Antenna (NAV)	X	1
12	MS27039C1-12	Screw	X	2
13	A806-213	Cable (Ref, to radio; NAV)		
14	A806-208	Cable (Ref, to radio; GS)		
15	CI 507*	Diplexer	X	1
16	CI 505*	Dual Diplexer (used only with two NAV receivers and glideslope)	X	1
17	MS21042L08	Nut	X	2
18	NAS1149FN816P	Washer	X	2
19	C359-1	Console Panel – LH (Ref)		
20	MS27039C0806	Screw	X	2
21	B161-4	Spirap	X	A/R

NOTES * Comant Industries part no.

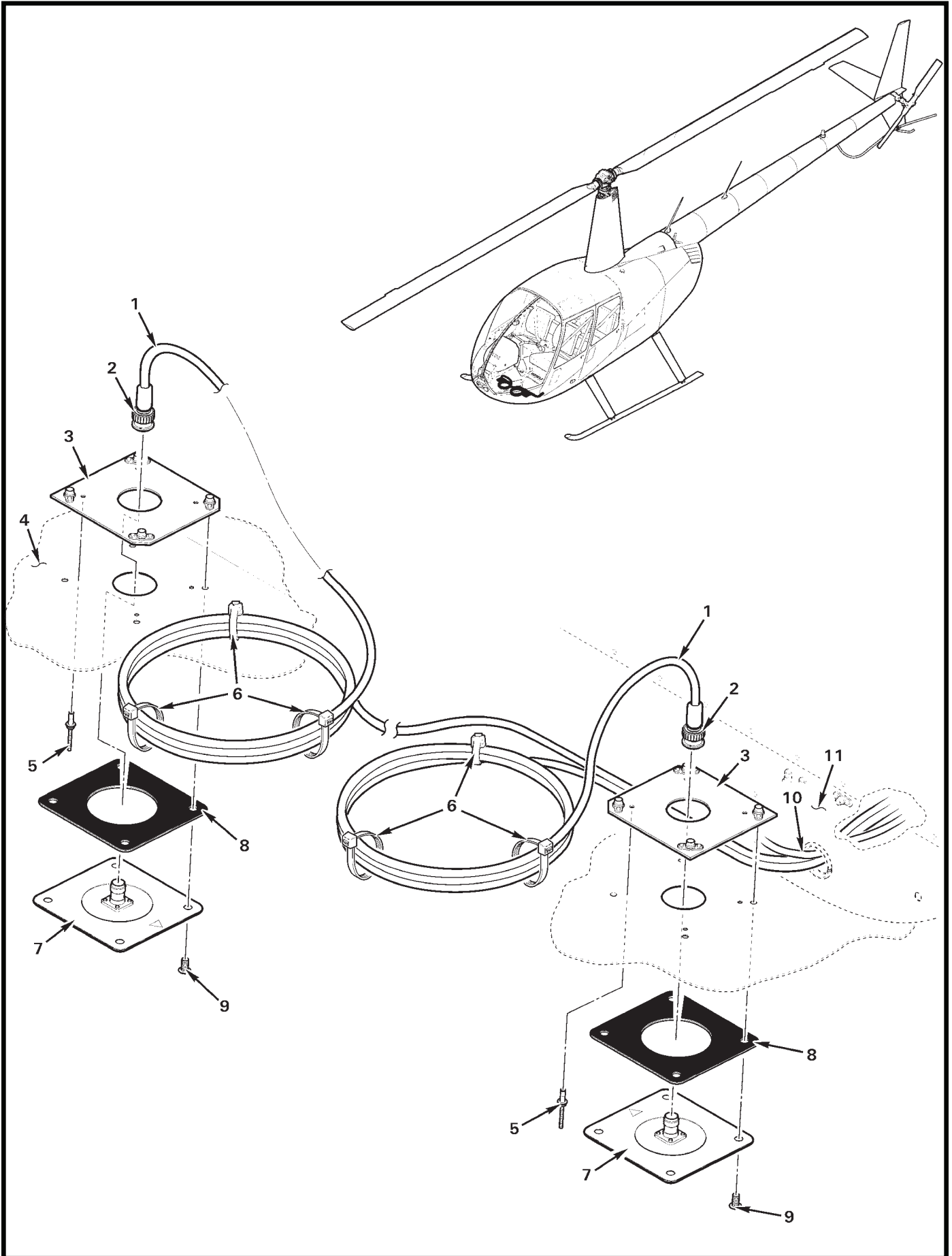

FIGURE AND INDEX NUMBER	PART NUMBER	DESCRIPTION	PARTS AVAIL	QTY PER ASSY
RADAR ALTIMETER ANTENNAS				
6-17-1	—	Cable (to Radar Altimeter; do not alter length)	O	1
2	0129-0017-00	Connector (TNC)	O	2
3	B420-1	Plate Assembly	X	2
4	C272	Chin (Ref)		
5	NAS9302B-4-02	Rivet (or NAS1921B04S02)	X	8
6	MS3367-5-9	Ty-Rap	X	A/R
7	9-1203-115-00*	Antenna (Incl items 8 and 9)	O	2
8	—	Gasket	O	2
9	—	Screw (alternate part no. MS24694-S51)	O	8
10	—	Cable (wire no. 1329, to indicator; Ref)		
11	D230	Bulkhead (Ref)		

NOTES * Free Flight Systems part no.; contact manufacturer to replace component.

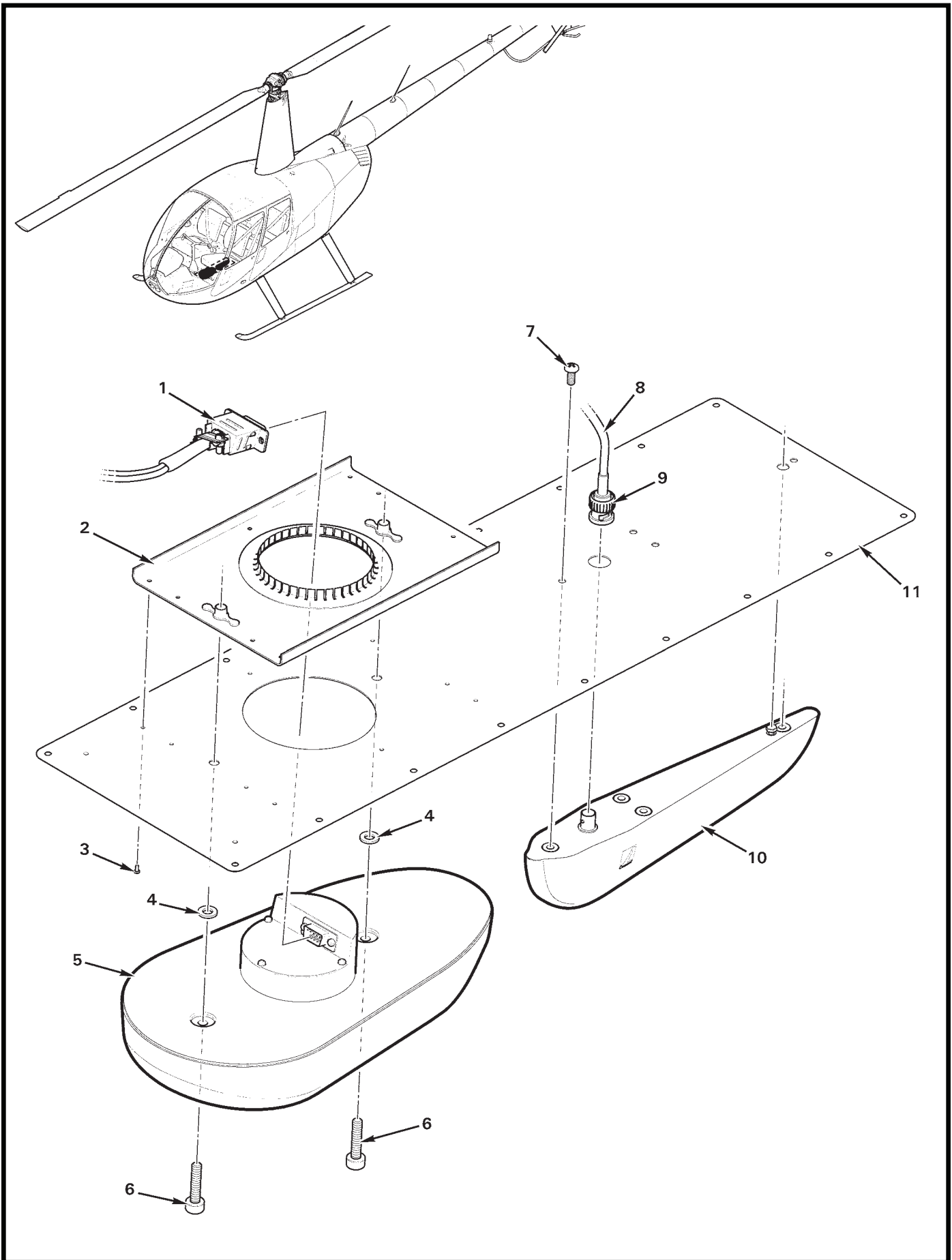

FIGURE AND INDEX NUMBER	PART NUMBER	DESCRIPTION	PARTS AVAIL	QTY PER ASSY
ADF/MARKER BEACON ANTENNAS				
6-19-1	200-2586-00	Cable Assembly	O	1
2	047-04956-0003	Doubler Plate	O	1
3	MS20470AD3	Rivet	X	10
4	NAS1149F0463P	Washer	X	2
5	KA44B*	Antenna – ADF (Ref, includes item 1, 2, and 6)		
6	C89-05534-0020	Screw	O	2
7	MS27039C1-07	Screw (install using item 12 on threads)	X	4
8	C850-210	Cable (Ref)		
9	5225395-6	Plug	X	1
10	CI 102**	Antenna – Marker Beacon	X	1
11	C794-1	Panel (Ref)		
12	B270-11	Adhesive (1.69-oz bottle)	X	A/R

NOTES * King Radio Corp part no.
 ** Comant Industries part no.

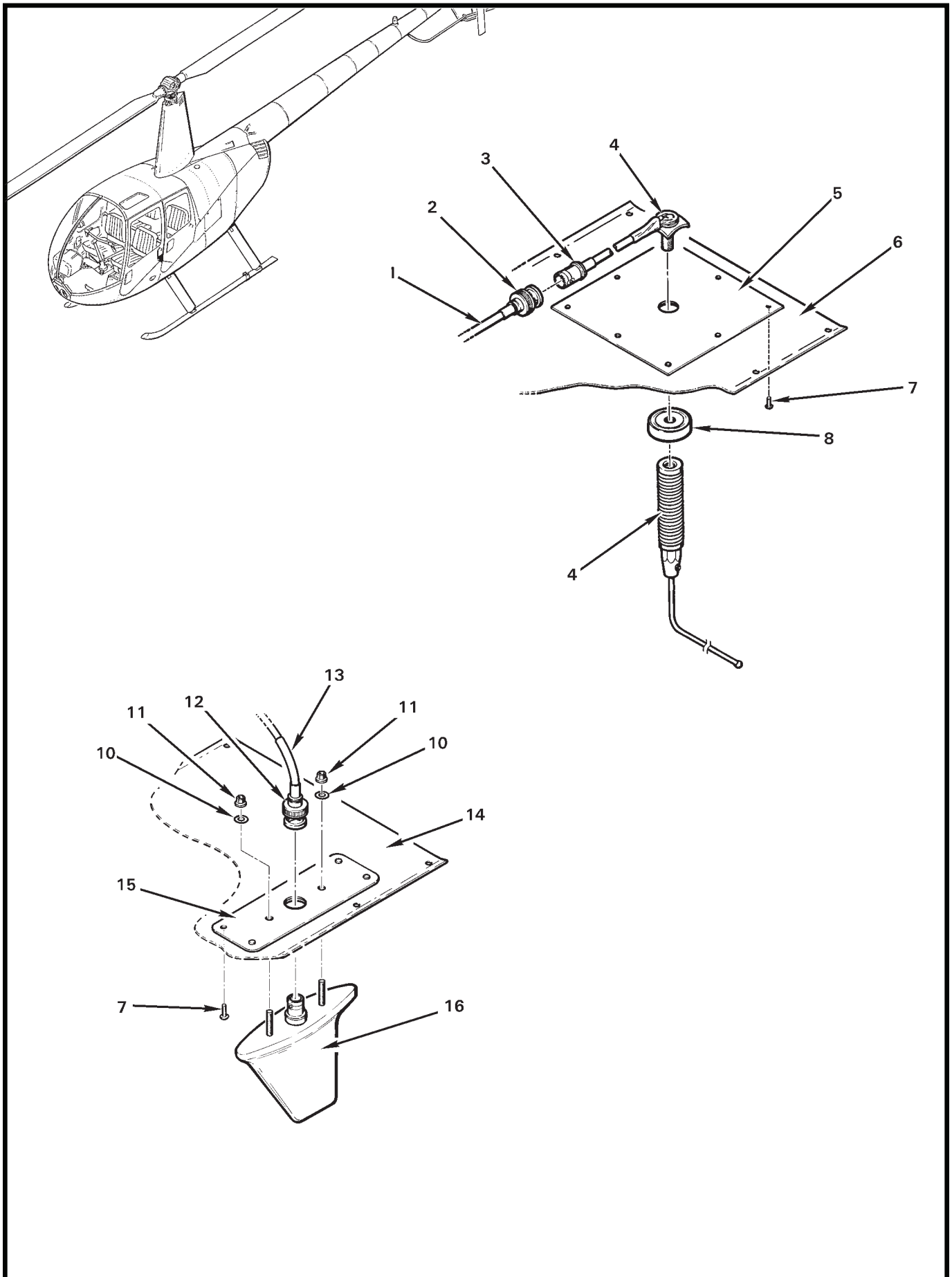

FIGURE AND INDEX NUMBER	PART NUMBER	DESCRIPTION	PARTS AVAIL	QTY PER ASSY
FM/DME ANTENNAS				
6-21-1	C850-943	Cable (Ref)		
2	225395-1*	Plug	X	1
3	225396-1*	Jack	X	1
4	LMWBQK	Antenna - FM (includes item 8; install using item 9 on threads) . .	X	1
5	A830-3	Doubler	X	1
6	C794-1	Panel (Ref)		
7	MS20470AD3	Rivet	X	1
8	—	Spacer	O	1
9	B270-11	Adhesive (1.69-oz bottle)	X	A/R
10	NAS1149FN816P	Washer	X	2
11	MS21042L08	Nut	X	2
12	225395-6*	Plug	X	1
13	C850-452	Cable (Ref)		
14	C794-3	Panel (Ref)		
15	B10567	Doubler	O	1
16	CI-105-16*	Antenna - DME (alternate part no. KA 60**)	X	1

NOTES * Comant Industries part no.
 ** Honeywell Bendix/King part no.

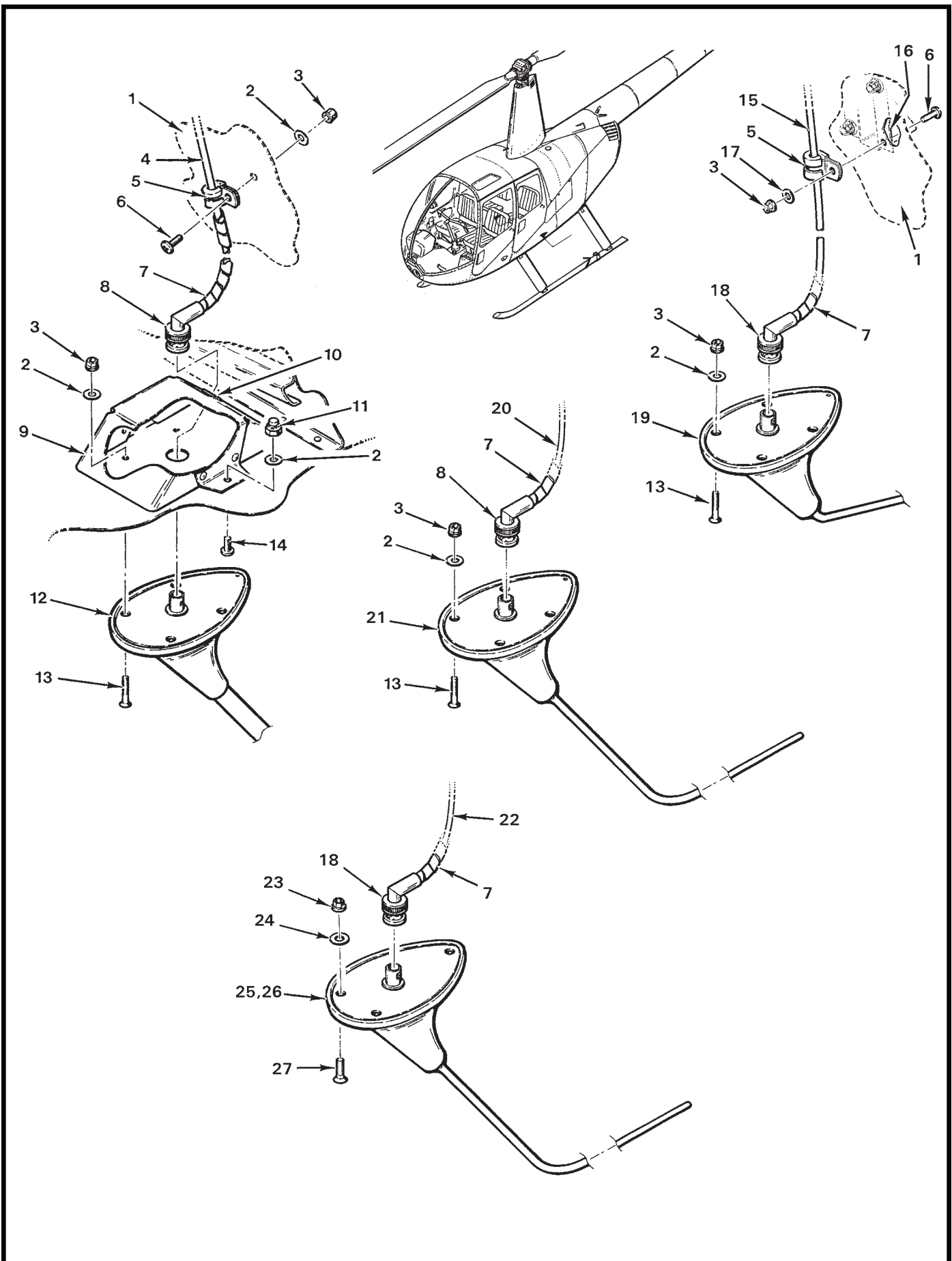

FIGURE AND INDEX NUMBER	PART NUMBER	DESCRIPTION	PARTS AVAIL	QTY PER ASSY
AFT BELLY ANTENNAS				
6-23-1	—	Firewall (vertical; Ref)		
2	NAS1149FN816P	Washer	X	A/R
3	MS21042L08	Nut	X	6
4	C850-1012	Wire (Ref)		
5	MS21919WDG3	Clamp	X	1
6	MS27039C0806	Screw	X	1
7	B161-4	Spirap	X	1
8	225973-4	Plug	X	1
9	D384-2	Cover	X	1
10	NAS557-8A	Grommet	X	1
11	B340-4	Nut	X	2
12	CI 177	Antenna - FM (148-174 MHz)	X	1
	CI 177-1	Antenna - FM (138-174 MHz)	X	1
	CI 177-20	Antenna - FM (450-470 MHz)	X	1
13	MS24694-C7	Screw	X	4
14	MS27039C0805	Screw	X	2
15	C850-1395	Cable (Ref)		
16	A454-1	Support - Gascolator (Ref, see also Figure 28-1)		
17	NAS1149FN832P	Washer	X	1
18	225974-1	Plug	X	1
19	CI 222	Antenna - AM/FM (RH mount, non-ENG ships. 88-108 MHz, 550-1600 kHz.)	X	1
20	C850-1214	Cable (Ref)		
21	CI 122	Antenna - Com (118-136 MHz)	X	1
22	C850-941	Cable (Ref, LH antenna installation)		
	C850-942	Cable (Ref, RH antenna installation)		
	C850-1415	Cable (Ref; used with item 26)		
23	MS21042L3	Nut	X	3
24	NAS1149F0332P	Washer	X	3
25	CI 292-3	Antenna - FM (RH or LH mount, 138-174 MHz; supersedes DMC-63-3-A antenna.)	X	1
26	D721-1	Antenna - FM (LH mount, 220-225 MHz)	X	1
27	MS24694-S51	Screw	X	3

NOTES

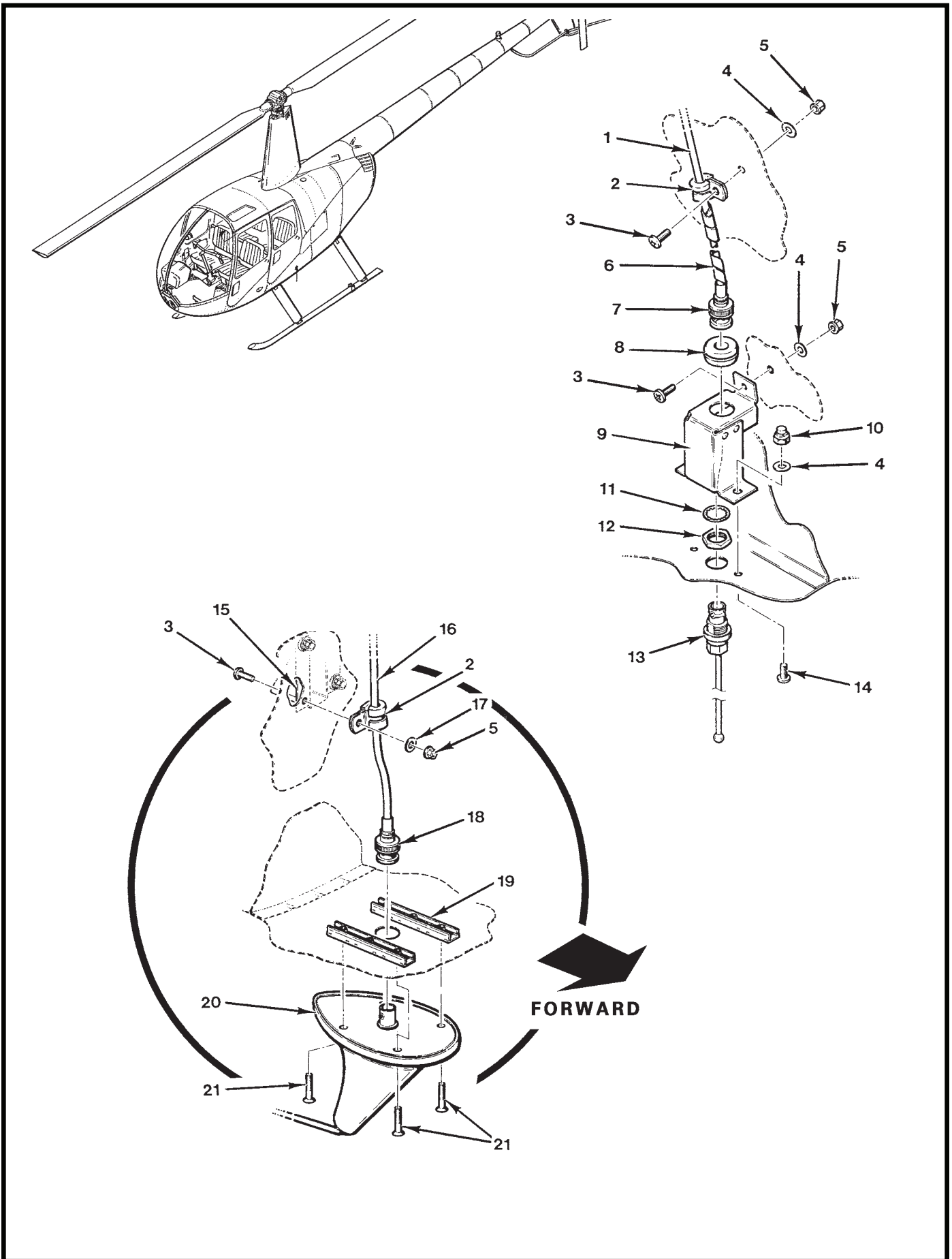

FIGURE AND INDEX NUMBER	PART NUMBER	DESCRIPTION	PARTS AVAIL	QTY PER ASSY
AFT BELLY ANTENNAS				
6-25-1	C850-1012	Cable (Ref)		
2	MS21919WDG3	Clamp	X	1
3	MS27039C0806	Screw	X	2
4	NAS1149FN816P	Washer	X	4
5	MS21042L08	Nut	X	1
6	B161-4	Spirap	X	A/R
7	225395-6	Plug	X	1
8	MS35489-40	Grommet	X	1
9	D563-1	Cover	X	1
10	B340-4	Nut	X	1
11	—	Nut (Ref)	O	1
12	—	Washer (Ref)	O	1
13	CI 273	Antenna - FM (403-512 MHz, includes items 11 and 12)	X	1
14	MS27039C0805	Screw	X	2
15	A454-1	Support (Ref, see also Figure 28-1)		
16	C850-1219	Cable (Ref)		
17	NAS1149FN832P	Washer	X	1
18	225395-1	Plug	X	1
19	A738-21	Gang Channel (Ref)		
20	CI 122	Antenna - AM/FM (RH mount, ENG ships. 88-108 MHz/550-1600 kHz.)	X	1
21	MS24694-C7	Screw	X	4

NOTES

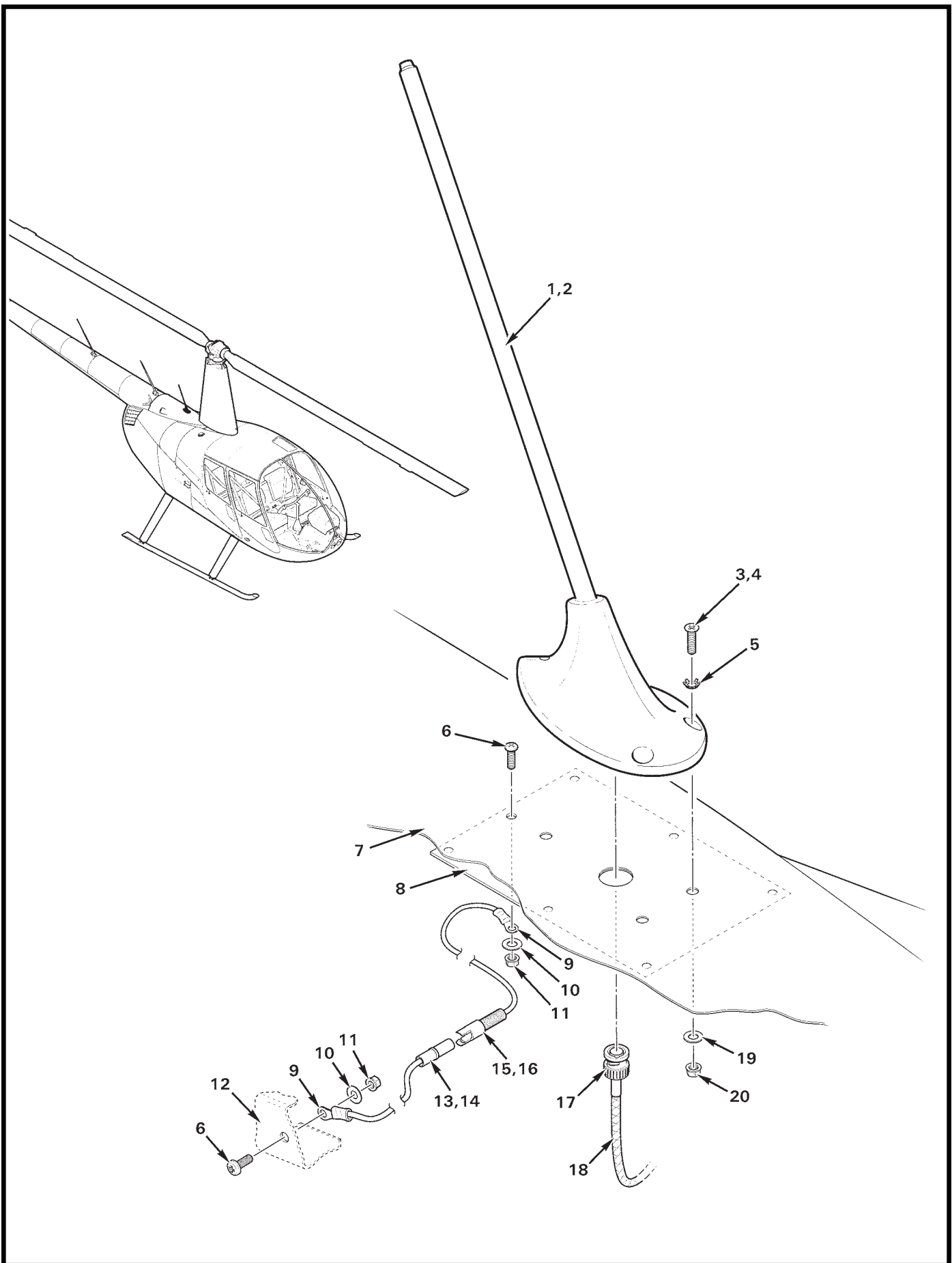

FIGURE AND INDEX NUMBER	PART NUMBER	DESCRIPTION	PARTS AVAIL	QTY PER ASSY
KANNAD ELT ANTENNA INSTALLATION				
6-27-1	AV-300	Antenna (install using item 2)	O	1
	1327-82*	Antenna (not shown; install using item 2)	O	1
2	B270-1	Sealant (2-oz tube)	X	A/R
3	24-84-5	Screw (Ref; supplied with item 1 [AV-300])	O	3
	MS24694-C51	Screw	X	3
4	B270-4	Sealant	X	A/R
5	11-33-2	Lockwasher (supplied with item 1)	O	3
6	MS27039C0806	Screw	X	2
7	C706-1	Tailcone Cowling (Ref)		
8	A837-2	Doubler	X	1
9	B260-3	Terminal	X	2
10	NAS1149FN816P	Washer	X	2
11	MS21042L08	Nut	X	2
12	C245-1	Channel (Ref)		
13	C049-16	Harness Assembly (includes items 9 thru 11, 14, and wire) . . .	X	1
14	B263-11	Housing	X	1
	B263-2	Socket	X	1
15	C049-15	Harness Assembly (includes items 9 thru 11, 16, and wire) . . .	X	1
16	B263-10	Housing	X	1
	B263-1	Pin	X	1
17	225395-6*	Plug	X	1
18	B274-518	Cable – Coaxial	X	A/R
19	NAS1149F0316P	Washer	X	3
20	MS21042L3	Nut	X	3

NOTES * Kannad part no.

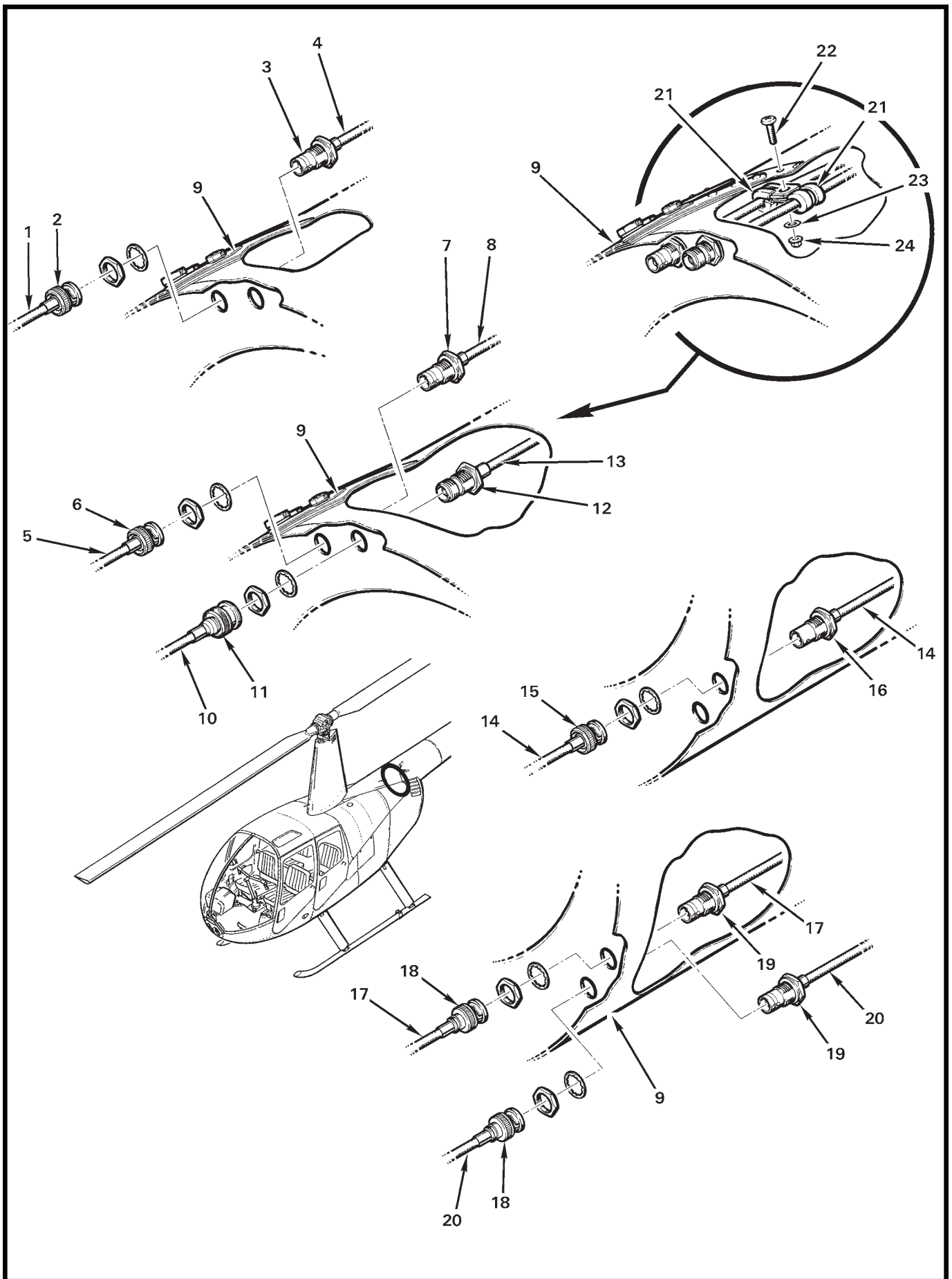

FIGURE AND INDEX NUMBER	PART NUMBER	DESCRIPTION	PARTS AVAIL	QTY PER ASSY
TAILCONE ANTENNA CABLE CONNECTORS				
6-29-1	C850-1317	Cable – Coaxial (FM or Com*)	X	A/R
2	5225395-6	Plug (FM or Com*)	X	1
3	5225398-6	Bulkhead Jack** (FM or Com*)	X	1
4	B274-518	Cable – Coaxial (FM or Com*)	X	A/R
5	C850-212	Cable – Coaxial (Com)	X	A/R
6	5225395-1	Plug (Com)	X	1
7	5225398-1	Bulkhead Jack** (Com)	X	1
8	B274-520	Cable – Coaxial (Com)	X	A/R
9	C023	Tailcone (Ref)		
10	C850-468	Cable – Coaxial (GPS)	X	A/R
11	5225555-6	Plug (GPS)	X	1
12	5225557-6	Bulkhead Jack** (GPS)	X	1
13	B274-518	Cable – Coaxial (GPS)	X	A/R
14	C023-1013	Cable – Coaxial* (VHF)	X	A/R
15	221185-2	Plug (VHF)	X	1
16	221221-2	Bulkhead Jack** (VHF)	X	1
17	C023-822	Cable – Coaxial (FM, lower aft tailcone installation for Police ships)	X	A/R
18	5225395-6	Plug (FM)	X	A/R
19	5225398-6	Bulkhead Jack** (FM)	X	A/R
20	C023-821	Cable – Coaxial (FM, lower forward tailcone installation for Police and ENG ships)	X	A/R
21	MS21919WDG3	Clamp	X	A/R
22	MS27039C0809	Screw	X	1
23	NAS1149FN816P	Washer	X	1
24	MS21042L08	Nut	X	1

NOTES * ENG ships.
 ** Includes washer and nut as shown.

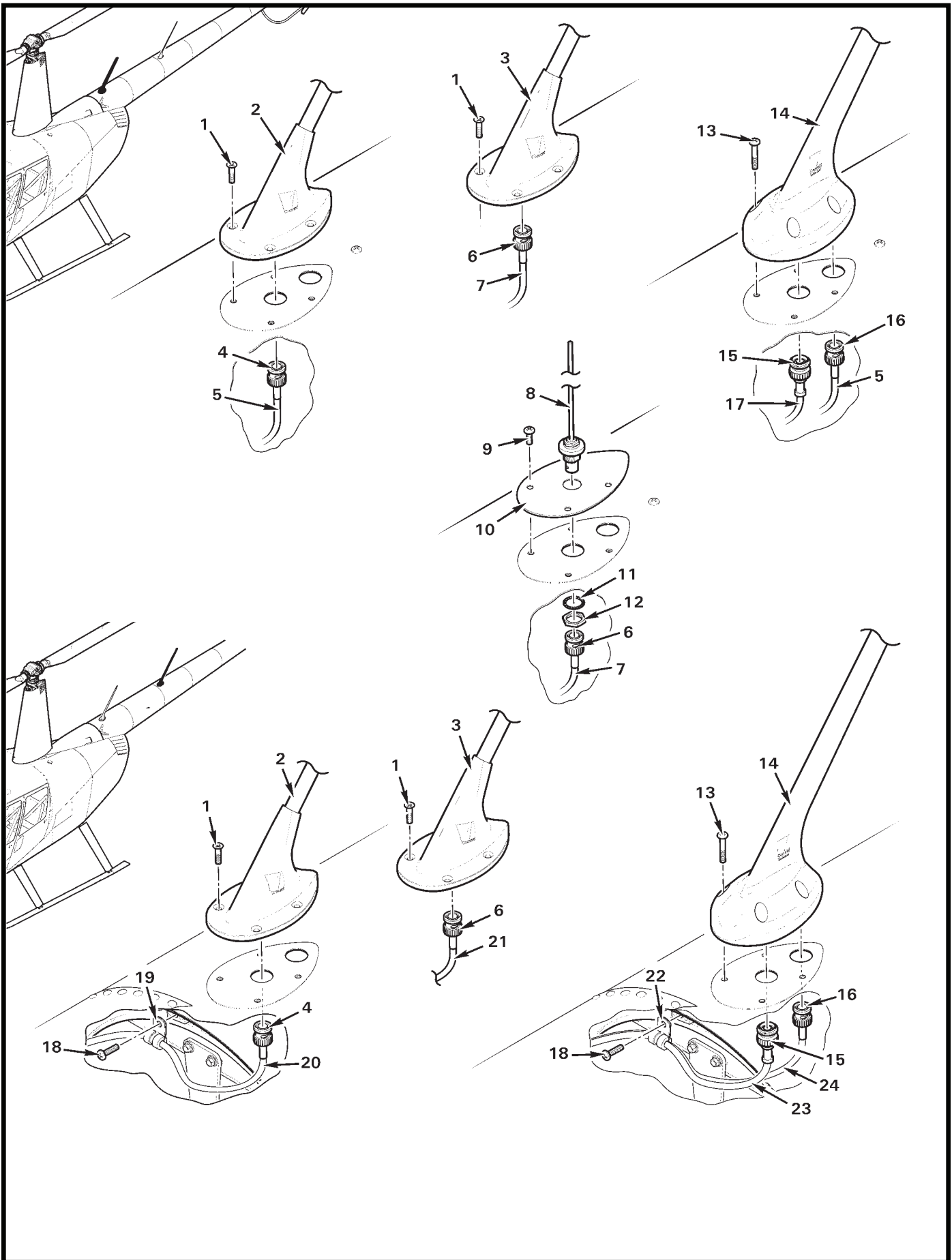

FIGURE AND INDEX NUMBER	PART NUMBER	DESCRIPTION	PARTS AVAIL	QTY PER ASSY
UPPER TAILCONE ANTENNAS				
6-31-1	MS24694-C7	Screw	X	4
2	CI 121*	Antenna – Com (118–156 MHz; install using item 25 around screw heads and holes. Alternate part no. CI-248-5*.)	X	1
3	CI 177*	Antenna – FM (148–174 MHz; install using item 25 around screw heads and holes)	X	1
	CI 177-1*	Antenna – FM (138–174 MHz)	X	1
	CI 177-20*	Antenna – FM (450–470 MHz)	X	1
4	5225395-1	Plug	X	1
5	C850-212	Cable	X	A/R
6	5225395-6	Plug	X	1
7	C850-1213	Cable (Ref; fwd antenna)		
	C850-1317	Cable (Ref; aft antenna)		
8	CI 271*	Antenna – FM (403–512 MHz; includes items 11 and 12, FWD or AFT location)	X	1
	CI 272-1*	Antenna – FM (403–512 MHz; includes items 11 and 12, FWD or AFT location)	X	1
	CI 273*	Antenna – FM (403–512 MHz; includes items 11 and 12, FWD or AFT location)	X	1
	CI 306*	Antenna – FM (800–870 MHz; includes items 11 and 12, FWD location only)	X	1
9	MS27039C0806	Screw	X	4
10	B322-4	Cover	X	1
11	—	Washer	O	1
12	—	Nut	O	1
13	MS27039C0813	Screw	X	4
14	CI-2580-200*	Antenna – Com/GPS (supersedes CI-4510-7C; install using item 25 around screw heads and holes)	X	1
15	5225555-6	Plug (GPS)	X	1
16	5225395-1	Plug (Com, standard)	X	1
	5225395-6	Plug (Com, ENG/Police ships)	X	1
17	C850-468	Cable (Ref)		
18	MS27039C0810	Screw	X	1
19	MS21919WDG3	Clamp	X	1
20	B274-520	Cable	X	A/R
21	B274-518	Cable	X	A/R
22	MS21919WDG6	Clamp	X	1
23	B274-518	Cable (GPS)	X	A/R

NOTES * Comant Industries part no.

Continues

FIGURE AND INDEX NUMBER	PART NUMBER	DESCRIPTION	PARTS AVAIL	QTY PER ASSY
UPPER TAILCONE ANTENNAS (Cont'd)				
6-31-24	B274-520	Cable (Ref; Com, standard)		
	B274-518	Cable (Ref; Com, ENG/Police ships)		
25	B270-4	Sealant	X	A/R

NOTES * Comant Industries part no.

Intentionally Blank

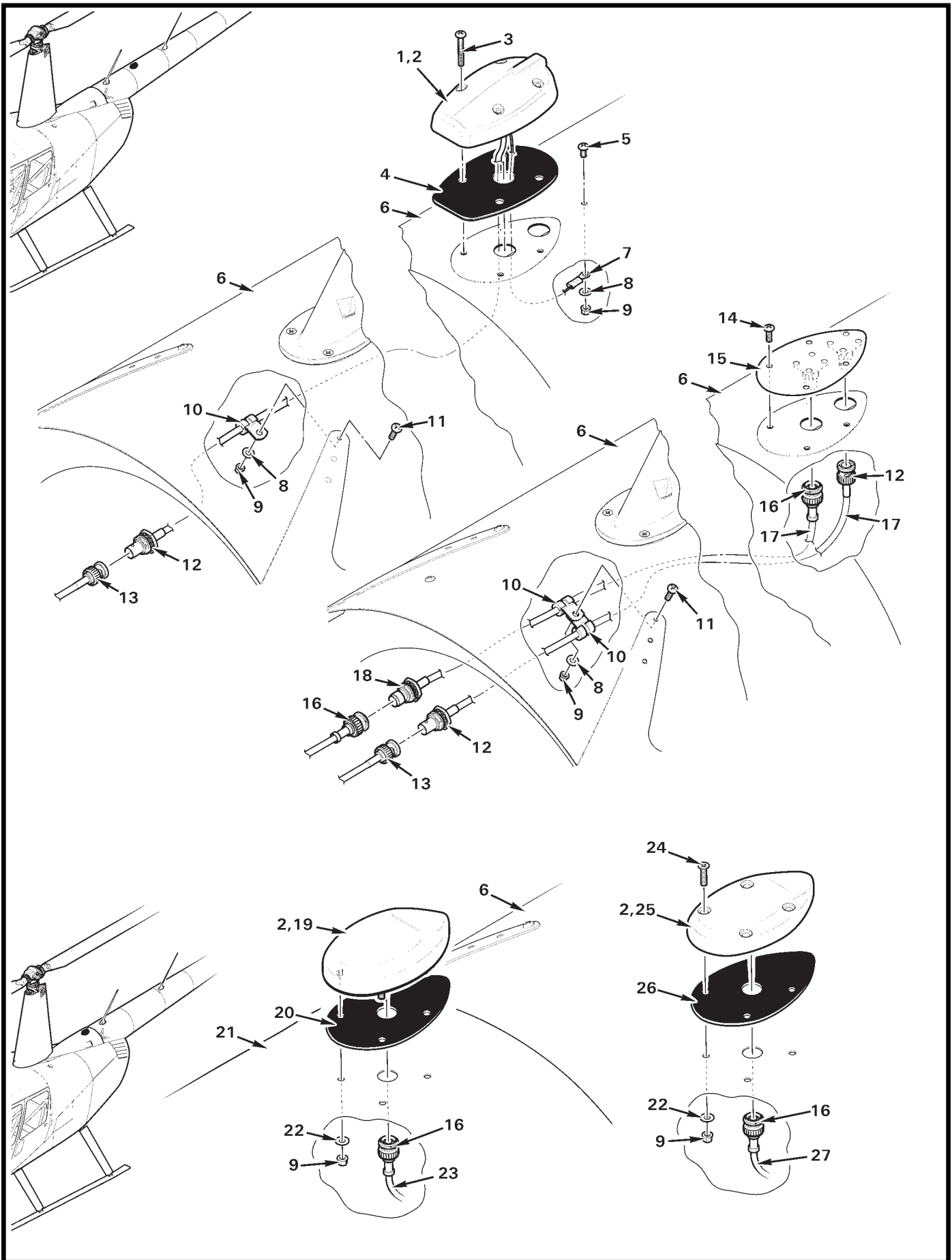

FIGURE AND INDEX NUMBER	PART NUMBER	DESCRIPTION	PARTS AVAIL	QTY PER ASSY
UPPER TAILCONE ANTENNAS				
6-35-1	921-00003-001	Antenna – RSM/GPS (install using item 2; install using item 28 on screw heads and holes; includes items 3 and 4)	X	1
2	B270-1	Sealant	X	A/R
3	—	Screw	O	4
4	—	Gasket	O	1
5	MS27039C0805	Screw	X	1
6	C023	Tailcone Assembly (Ref)		
7	B260-3	Terminal	X	1
8	NAS1149FN816P	Washer	X	2
9	MS21042L08	Nut (on optional antenna provisions [1])	X	2
10	MS21919WDG3	Clamp (on optional antenna provisions [2])	X	1
11	MS27039C0808	Screw	X	1
12	5225398-6	Bulkhead Jack	X	1
13	5225395-6	Plug (on optional antenna provisions [2])	X	1
14	MS27039C0807	Screw	X	4
15	B322-13	Cover Assembly	X	A/R
16	5225555-6	Plug (on optional antenna provisions [2])	X	1
17	B274-518	Cable (on optional antenna provisions [2])	X	1
18	5225557-6	Bulkhead Jack (on optional antenna provisions only)	X	1
19	GA 55	Antenna – XM (install using item 2; includes item 20)	X	1
20	—	Gasket	O	1
21	C706-1	Cowling (Ref)		
22	NAS1149FN832P	Washer	X	4
23	-2729	Cable	X	1
24	MS24694-C7	Screw	X	4
25	GA 35	Antenna – GPS (install using item 2; includes item 26)	X	1
26	—	Gasket	O	1
27	-468	Cable	X	1
28	B270-13	Sealant	X	A/R

NOTES * Comant Industries part no.

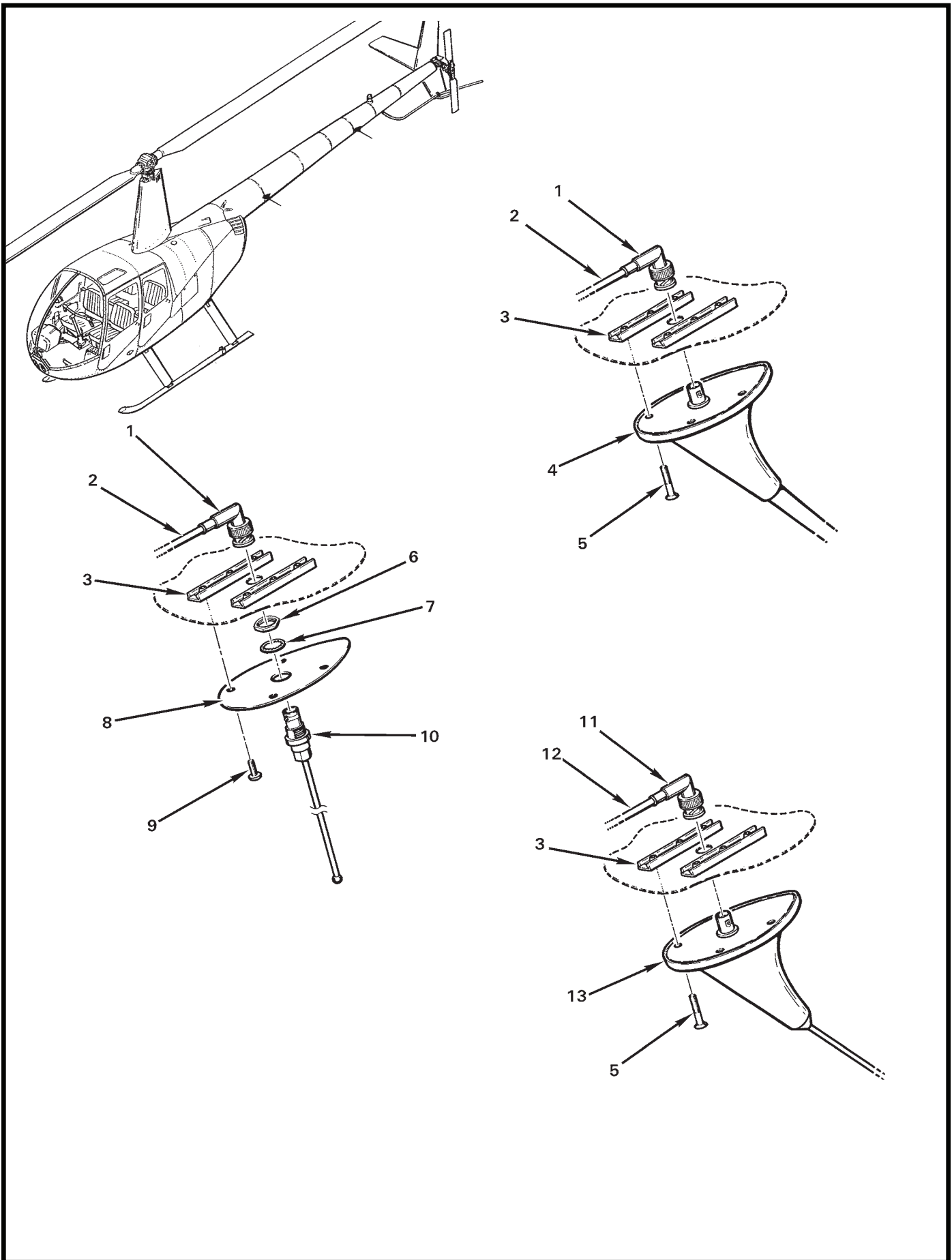

FIGURE AND INDEX NUMBER	PART NUMBER	DESCRIPTION	PARTS AVAIL	QTY PER ASSY
LOWER TAILCONE ANTENNAS				
6-37-1	5225973-4	Plug	X	1
2	C023-821	Cable (Ref, forward mount)		
	C023-822	Cable (Ref, aft mount)		
3	A738-21	Gang Channel (Ref)		
4	CI 177*	Antenna – FM (148–174 MHz)	X	1
	CI 177-1*	Antenna – FM (138–174 MHz)	X	1
	CI 177-20*	Antenna – FM (450–470 MHz)	X	1
5	MS24694-C7	Screw	X	4
6	—	Nut	O	1
7	—	Washer	O	1
8	B322-4	Cover	X	1
9	MS27039C0806	Screw	X	4
10	CI 273*	Antenna – FM (403–512 MHz, includes items 6 and 7)	X	1
11	221402-2	Plug	X	1
12	C023-1013	Cable (Ref)		
13	CI 122*	Antenna – VHF (118–136 MHz)	X	1

NOTES * Comant Industries part no.

Intentionally Blank

CHAPTER 8

WEIGHT AND BALANCE

<i>Figure</i>	<i>Title</i>	<i>Page</i>
8-1	Nose Ballast Installation	8.0
8-3	Empennage Ballast Installation	8.2

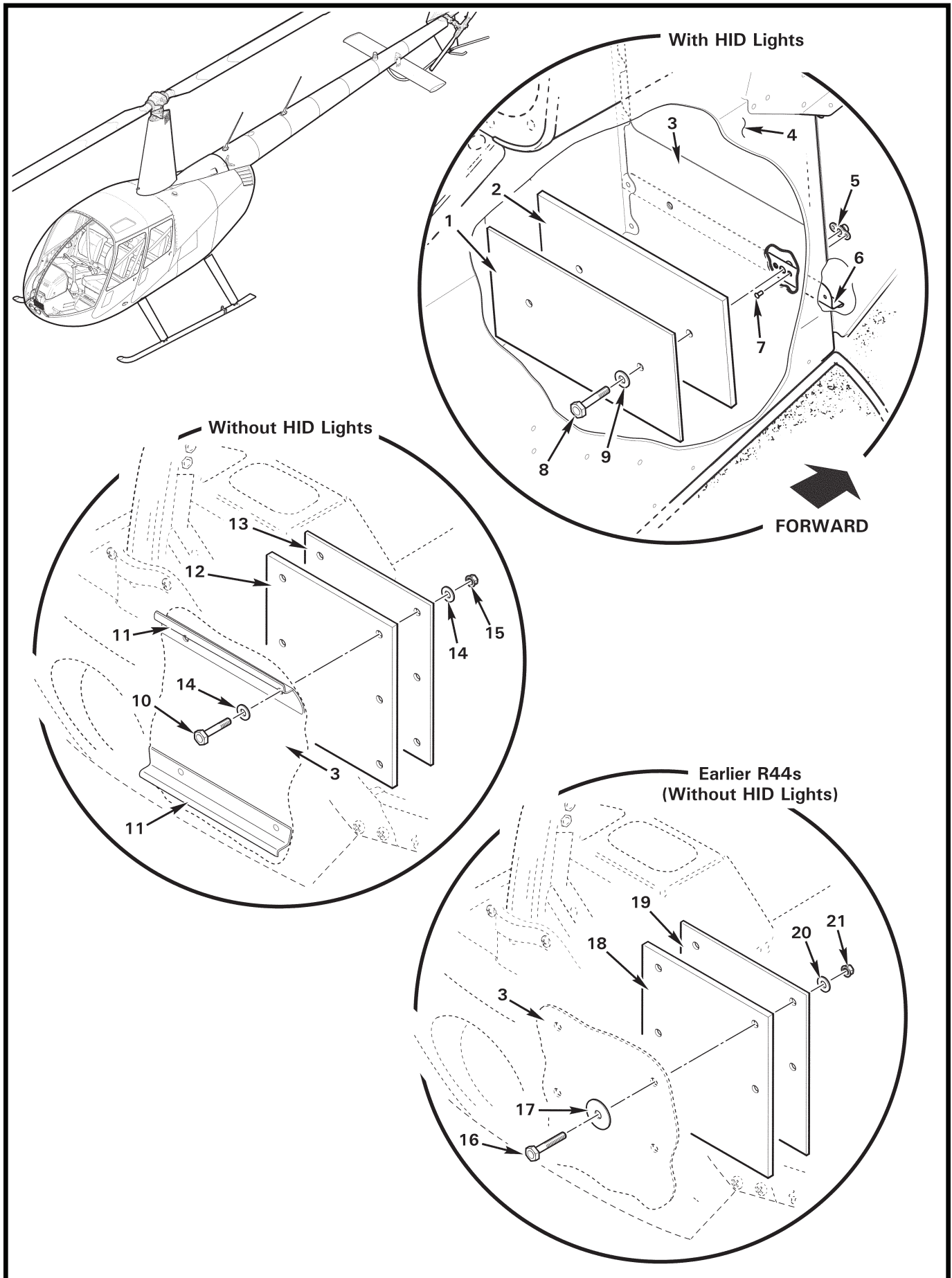

FIGURE AND INDEX NUMBER	PART NUMBER	DESCRIPTION	PARTS AVAIL	QTY PER ASSY
		NOSE BALLAST INSTALLATION* (NOT ELIGIBLE ON POLICE AND E.N.G. VERSIONS)		
8-1-1	A941-5	Ballast Plate (0.25 lb; compatible with B557 HID landing lights)	X	A/R
2	A941-6	Ballast Plate (1.25 lb; compatible with B557 HID landing lights)	X	A/R
3	C361	Console Panel (Ref)		
4	C033-1	Lower Console Assembly (Ref; see Figure 53-51)		
5	MS21069L3	Nutplate (Ref; see Figure 53-51)		
6	C360-4	Stiffener (Ref; see Figure 53-51)		
7	NAS1097AD3	Rivet (Ref; see Figure 53-51)		
8	NAS6603	Bolt (Select bolt length to meet torque requirements per R44 MM § 23-30 Part E. NAS428-3A14 or shorter bolt with excess threads exposed optional.)	X	2
9	NAS1149F0332P	Washer	X	2
		* * *		
10	NAS6603	Bolt (Select bolt length to meet torque requirements per R44 MM § 23-30 Part E. NAS428-3A14 or shorter bolt with excess threads exposed optional.)	X	4
11	C360-2	Stiffener (no longer available order items 6, 8 [2], and 9 [2])	O	2
12	A941-3**	Ballast Plate (1.00 lb; not compatible with B557 HID landing lights)	X	A/R
13	A941-2**	Ballast Plate (0.25 lb; not compatible with B557 HID landing lights)	X	A/R
14	NAS1149F0332P	Washer	X	8
15	D210-3	Nut	X	4
		* * *		
16	NAS428-3A-12	Bolt (or NAS428-3-12)	X	4
17	AN970-3	Washer	X	4
18	A941-3**	Ballast Plate (1.00 lb; no longer available, superseded by item 12)	O	A/R
19	A941-2**	Ballast Plate (0.15 lb; no longer available, superseded by item 13)	O	A/R
20	NAS1149F0332P	Washer	X	4
21	D210-3	Nut	X	4

NOTES * Refer to R44 MM Chapter 18 for maximum allowable nose ballast, & determine fixed ballast requirements.
 ** For use with R44 I helicopters S/N 1711 and prior, and R44 II helicopters S/N 11684 and prior, and S/N 11686 thru 11714, without B557 HID landing lights installed (refer to Figure 33-11).

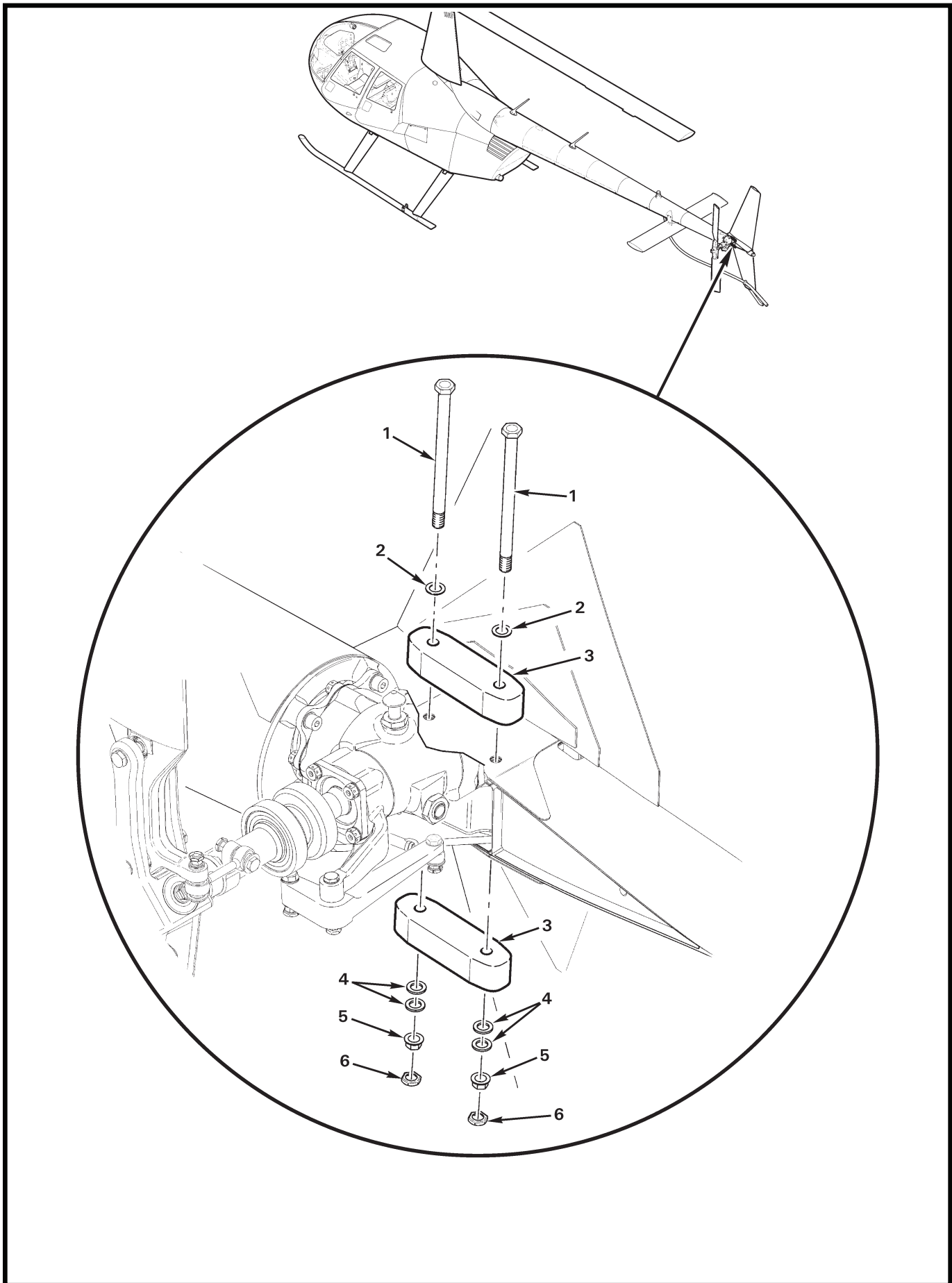

FIGURE AND INDEX NUMBER	PART NUMBER	DESCRIPTION	PARTS AVAIL	QTY PER ASSY
EMPENNAGE BALLAST INSTALLATION				
8-3-1	NAS6606-78	Bolt	X	2
2	NAS1149F0632P	Washer	X	2
3	D301-2*	Weight (1.5 lb; 4.65-in. x 1-in. not available unless previously installed, order item 7 as required. Contact RHC Technical Support with empty weight and balance for eligibility)	X	2
4	NAS1149F0663P	Washer ([1] or [2] under nut as required for 1 to 4 threads exposed)	X	A/R
5	D210-6	Nut	X	2
6	B330-19	Palnut	X	2
* * *				
7	KI-174	R44-series & R66 D301-7 Empennage 3.0 lb Ballast Installation Instructions	X	A/R

NOTES * Maximum allowable empennage ballast is 3.0 lb (except R44s with tailcone battery installed). One upper and one lower weight are required. Refer to R44 MM Chapter 18 to determine fixed ballast requirements.

Intentionally Blank

CHAPTER 9
GROUND HANDLING

<i>Figure</i>	<i>Title</i>	<i>Page</i>
9-1	Ground Handling Wheel Assembly	9.0
9-5	Ground Handling Wheel Assembly - Pop-Out Floats	9.4
9-9	Ground Handling Wheel Assembly - Fixed Floats	9.8
9-11	Ground Handling Ball Installation	9.10

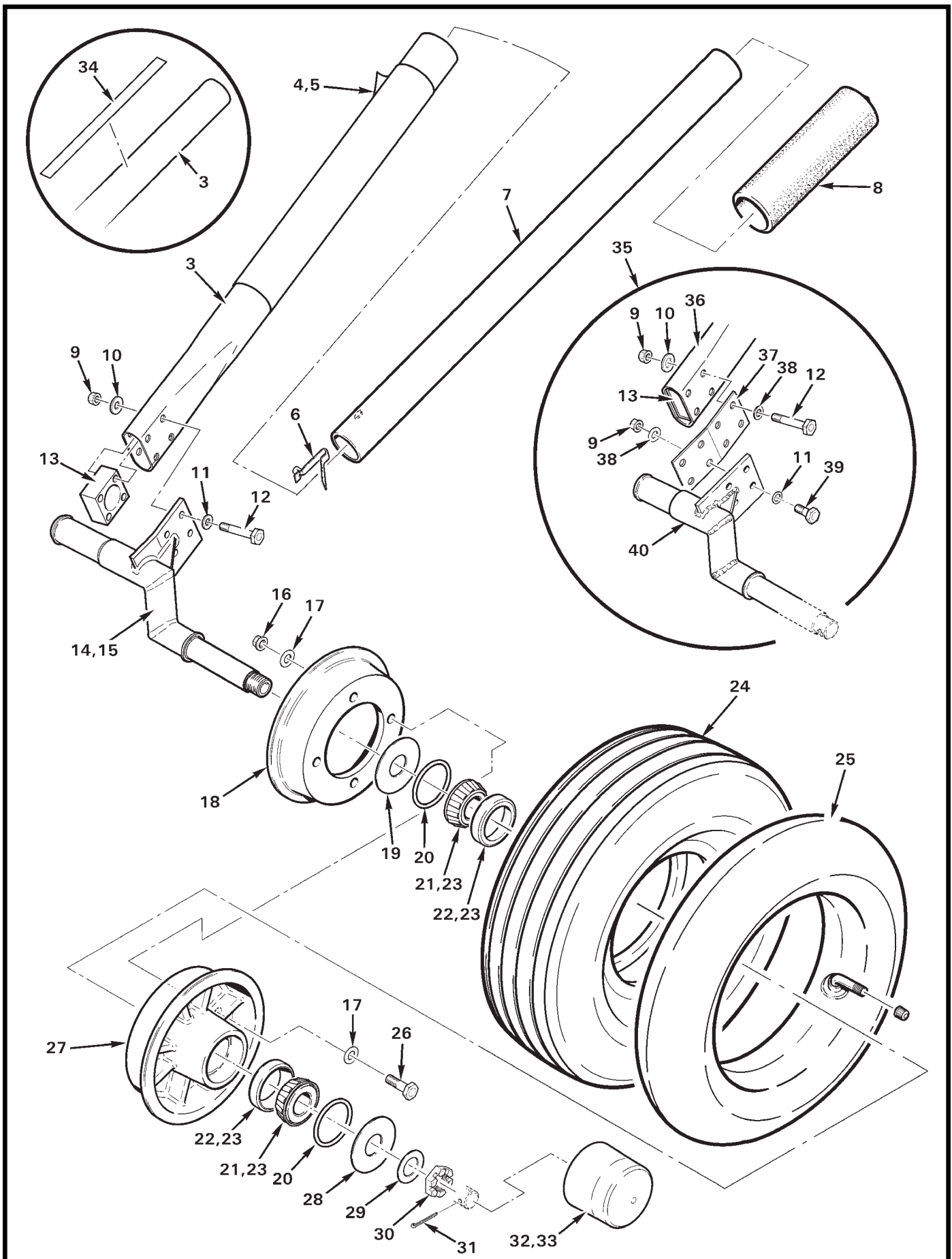

FIGURE AND INDEX NUMBER	PART NUMBER	DESCRIPTION	PARTS AVAIL	QTY PER ASSY
GROUND HANDLING WHEEL ASSEMBLY				
9-1-1	C063-6	Ground Handling Wheel Assembly – RH (Incl items 3, 4, 8, 9 thru 14, and 16 thru 33)	X	1
2	C063-5	Ground Handling Wheel Assembly – LH (Incl items 3, 4, 6, 8, 9 thru 13, and 15 thru 33; not shown)	X	1
3	C718-4	Lever	X	1
4	MT935-16	Decal – “RIGHT, INSTALL FROM INBOARD SIDE / WARNING: GRIP...” (install on C063-6 [RH] ground handling wheel assembly only)	X	1
5	MT935-15	Decal – “LEFT, INSTALL FROM INBOARD SIDE / WARNING: GRIP...” (install on C063-5 [LH] ground handling wheel assembly only)	X	1
6	A795-4	Pin	X	1
7	C718-1	Tube Assembly (Incl items 6 and 8)	X	1
8	A601-5	Grip	X	1
9	D210-3	Nut	X	4
10	NAS1149F0363P	Washer	X	4
11	NAS620-10L	Washer	X	4
12	NAS6603-12	Bolt	X	4
13	C915-1	Spacer	X	1
14	C717-14	Shaft Assembly (RH)	X	1
15	C717-13	Shaft Assembly (LH, not shown)	X	1
16	MS21042L4	Nut	X	4
17	NAS1149F0432P	Washer	X	8
18	MT947-2	Rim	X	1
19	MT141-3	Washer	X	1
20	A215-123	O-Ring	X	2
21	C646-9*	Cone (contact RHC Customer Service for replacement)	X	2
22	C646-10*	Cup (contact RHC Customer Service for replacement)	O	2
23	A257-5	Grease	X	A/R
24	MT936-5	Tire	X	1
25	MT936-6	Tube – Inner	X	1
26	NAS6604-6	Bolt	X	4
27	MT947-1	Rim	X	1
28	A214-12	Washer	X	1
29	NAS1149F0832P	Washer (for shimming)	X	A/R
30	AN320-8	Nut	X	1

NOTES * Install using item 24.

Continues

FIGURE AND INDEX NUMBER	PART NUMBER	DESCRIPTION	PARTS AVAIL	QTY PER ASSY
GROUND HANDLING WHEEL ASSEMBLY (Cont'd)				
9-1-31	MS24665-285	Cotter Pin	X	1
32	A959-11	Cap (install using item 33)	X	1
33	B270-15	Adhesive	X	A/R
34	A654-81	Decal (wheel installation instructions, C063 assembly, revision "L" and prior; used with item 40)	X	1
* * *				
35	KI-210*	Ground Handling Wheel Modification Kit (Incl items 9 thru 12, 31, and 37 thru 39)	X	1
36	C718-2	Lever Assembly (Ref)		
37	C717-7*	Plate	X	1
38	NAS1149F0332P*	Washer	X	8
39	NAS6603-4*	Bolt	X	4
40	C717-11	Shaft Assembly (Ref, LH and RH)		

NOTES * Refer to R44 Service Letter SL-41.

Intentionally Blank

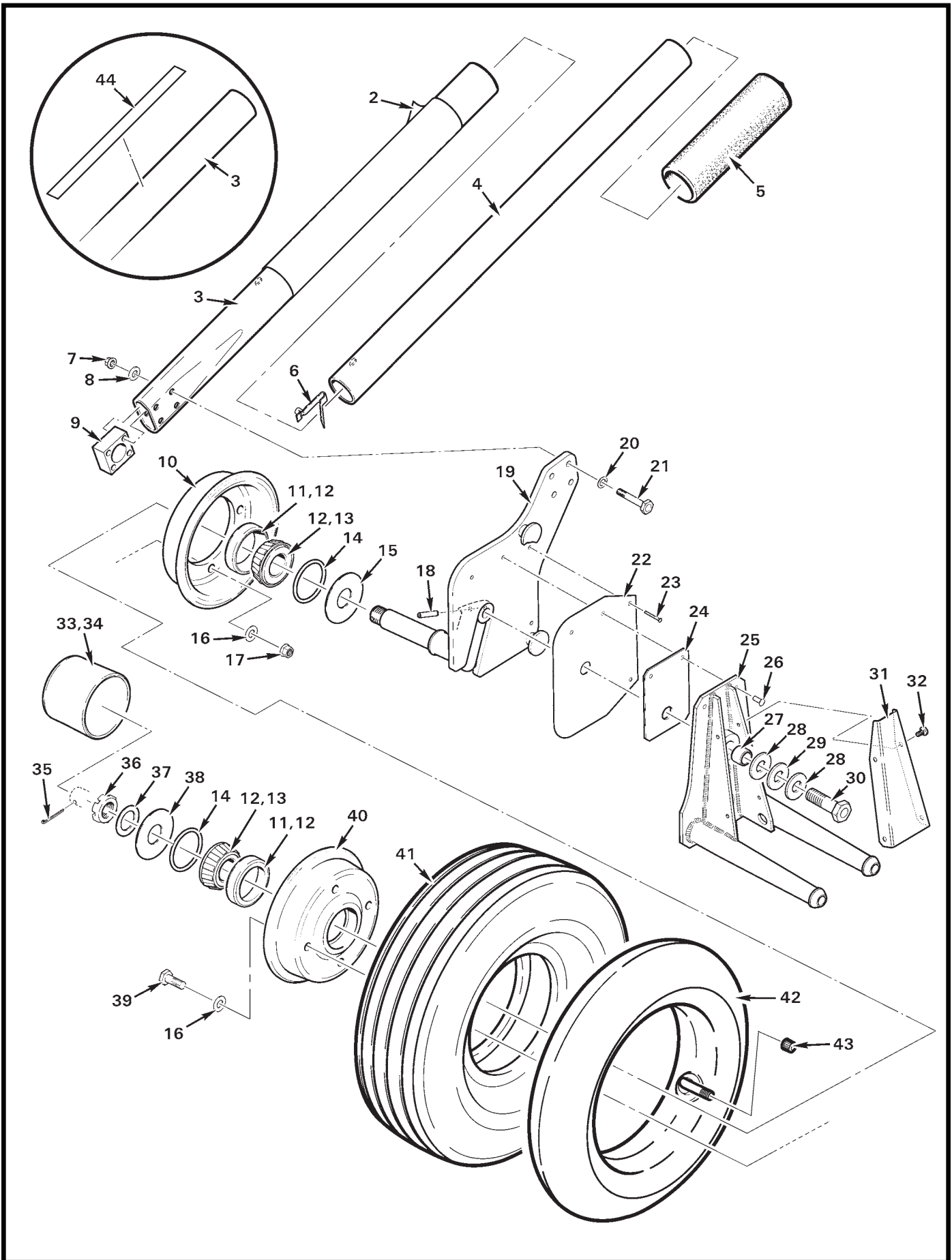

FIGURE AND INDEX NUMBER	PART NUMBER	DESCRIPTION	PARTS AVAIL	QTY PER ASSY
		GROUND HANDLING WHEEL ASSEMBLY - POP-OUT FLOATS		
9-5-1	MT980-1	Ground Handling Wheel Assembly - LH (Incl items 2 thru 4, and 7 thru 42)	X	1
	MT980-2	Ground Handling Wheel Assembly - RH (Incl items 2 thru 4, and 7 thru 42)	X	1
2	MT935-15	Decal (wheel installation instructions, LH)	X	1
	MT935-16	Decal (wheel installation instructions, RH; not shown)	X	1
3	C718-4	Lever	X	1
4	C718-1	Tube Assembly (Incl items 5 and 6)	X	1
5	A601-5	Grip	X	1
6	A795-4	Pin	X	1
7	MS21042L3	Nut	X	4
8	NAS1149F0363P	Washer	X	4
9	C915-1	Spacer	X	1
10	MT947-2	Rim	X	1
11	C646-10*	Cup (contact Customer Service for replacement)	O	2
12	A257-5	Grease	X	A/R
13	C646-9*	Cone	X	2
14	A215-123	O-Ring	X	2
15	MT141-3	Washer	X	1
16	NAS1149F0432P	Washer	X	8
17	MS21042L4	Nut	X	4
18	MS16562-35	Spring Pin	X	1
19	MT982-13	Shaft Weldment (LH, shown)	X	1
	MT982-14	Shaft Weldment (RH, not shown)	X	1
20	NAS1149F0332P	Washer	X	4
21	NAS6603-13	Bolt	X	4
22	MT982-7	Pad	X	1
23	MS20615-4M	Rivet	X	2
24	MT981-6	Pad	X	1
25	MT981-1	Support Weldment	X	1
26	MS20426AD4	Rivet	X	2
27	O6DU06	Bearing	X	1

NOTES * Install using item 12.

Continues

FIGURE AND INDEX NUMBER	PART NUMBER	DESCRIPTION	PARTS AVAIL	QTY PER ASSY
GROUND HANDLING WHEEL ASSEMBLY - POP-OUT FLOATS (Cont'd)				
9-5-28	MT141-1	Washer	X	2
29	MT141-2	Washer (teflon-coated, one side)	X	1
30	NAS6606-10	Bolt	X	1
31	MT981-7	Cover	O	1
32	MS35206-226	Screw	X	4
33	A959-11	Cap (install using item 34)	X	1
34	B270-15	Adhesive	X	A/R
35	MS24665-285	Cotter Pin	X	1
36	AN320-8	Nut	X	1
37	NAS1149F0832P	Washer (for shimming)	X	A/R
38	A214-12	Washer	X	1
39	NAS6604-6	Bolt	X	4
40	MT947-1	Rim	X	1
41	MT936-5	Tire	X	1
42	MT936-6	Tube - Inner (Incl item 43)	X	1
43	—	Cap - Valve	O	1

44	A654-81	Decal (wheel installation instructions, MT980 assembly revision "E" and prior)	X	1

NOTES

Intentionally Blank

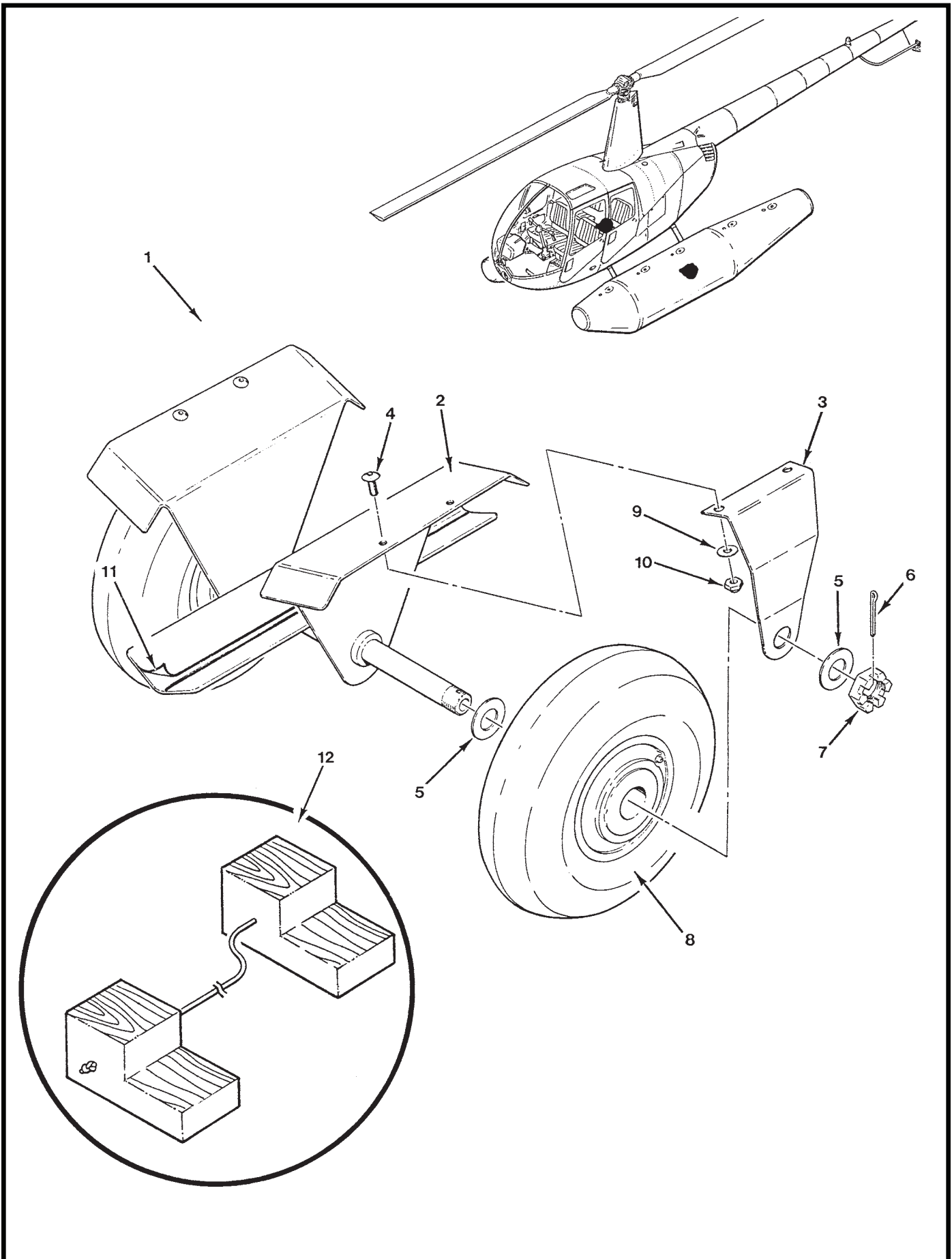

FIGURE AND INDEX NUMBER	PART NUMBER	DESCRIPTION	PARTS AVAIL	QTY PER ASSY
GROUND HANDLING WHEEL ASSEMBLY - FIXED FLOATS				
9-9-1	B132-1	Ground Handling Wheel Assembly (Incl items 2 thru 11)	X	1
2	B131-1	Frame Weldment	O	1
3	B294-1	Support	X	1
4	A142-2	Screw	X	4
5	NAS1149F1032P	Washer	X	2
6	MS24665-355	Cotter Pin	X	2
7	AN320-10	Nut	X	2
8	B132-2	Wheel	X	2
9	NAS1149FN816P	Washer	X	4
10	MS21042L08	Nut	X	4
11	A751-2	Strip	X	2
12	B133-5	Block Assembly	X	1

NOTES

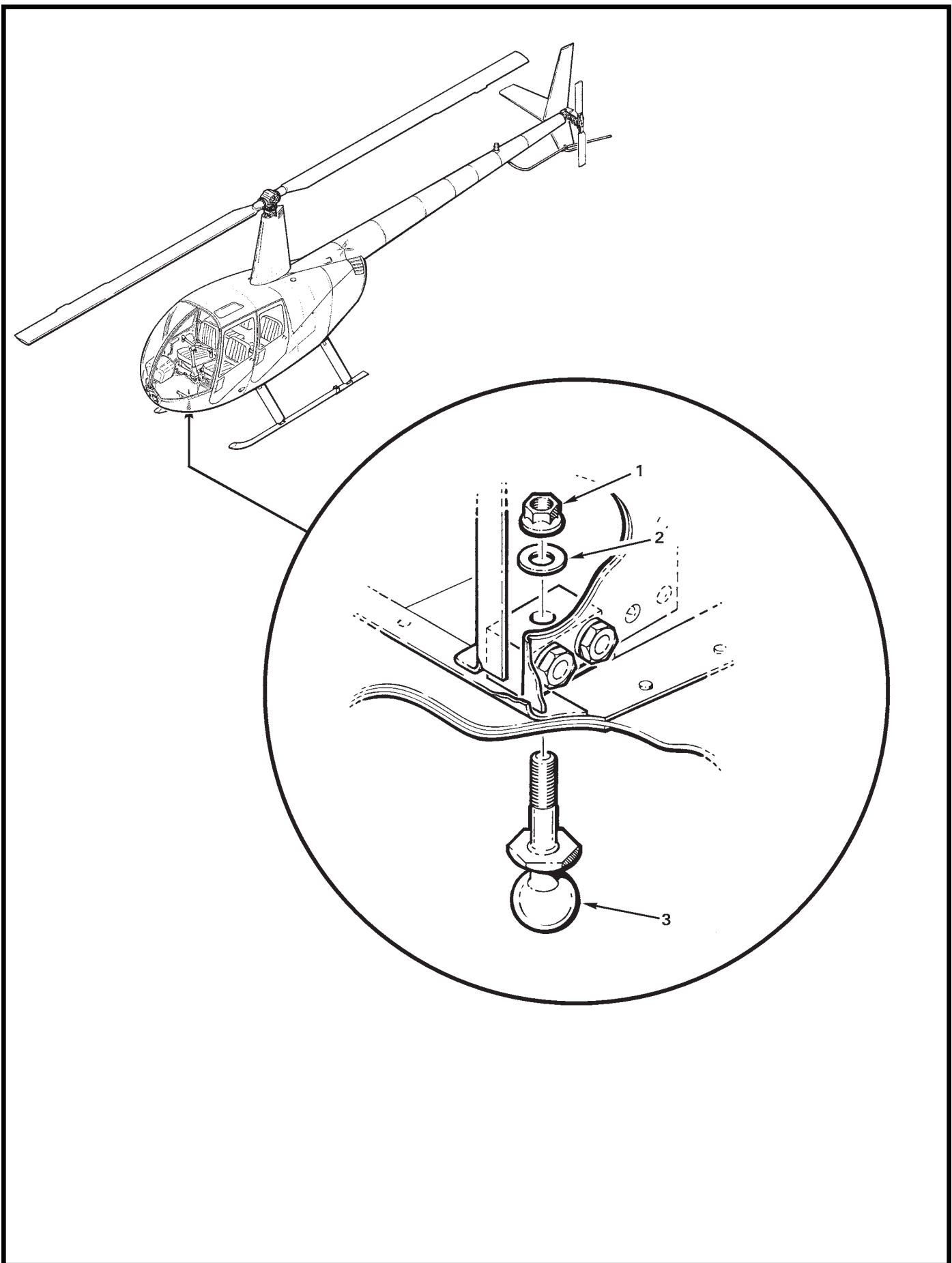

FIGURE AND INDEX NUMBER	PART NUMBER	DESCRIPTION	PARTS AVAIL	QTY PER ASSY
GROUND HANDLING BALL INSTALLATION				
9-11-1	MS21042L5	Nut	X	1
2	NAS1149F0532P	Washer	X	1
3	C700-7	Ball	X	1
NOTES				

Intentionally Blank

CHAPTER 10
PARKING AND STORAGE

<i>Figure</i>	<i>Title</i>	<i>Page</i>
10-1	Main Rotor Blade Tie-Downs	10.0
10-3	Cabin Covers	10.2
10-5	Tie-Down Installation	10.4
10-7	Hardpoint Hinge and Tie-Down Ring Installations	10.6
10-9	Main Rotor Blade Support Installation	10.8

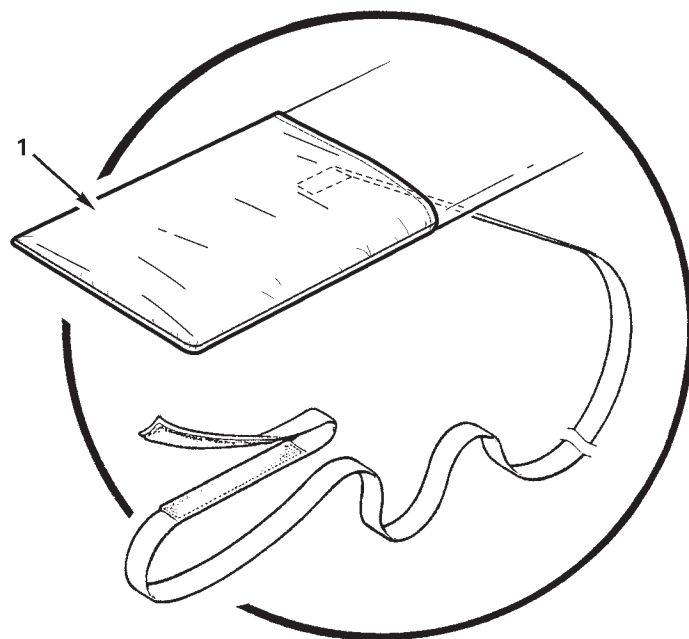
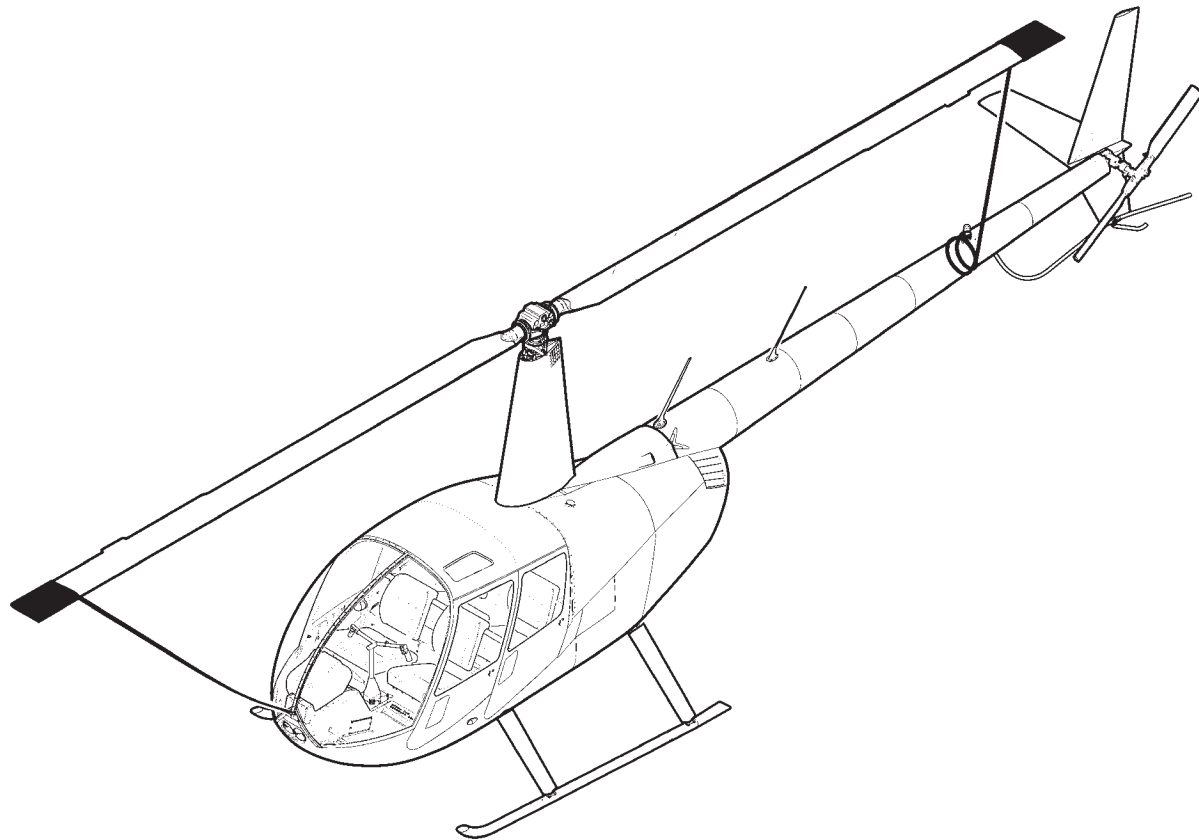

FIGURE AND INDEX NUMBER	PART NUMBER	DESCRIPTION	PARTS AVAIL	QTY PER ASSY
10-1-1	MT290-2	<p>MAIN ROTOR BLADE TIE-DOWNS</p> <p>Main Rotor Blade Tie-Down (set of two)</p>	X	1
NOTES				

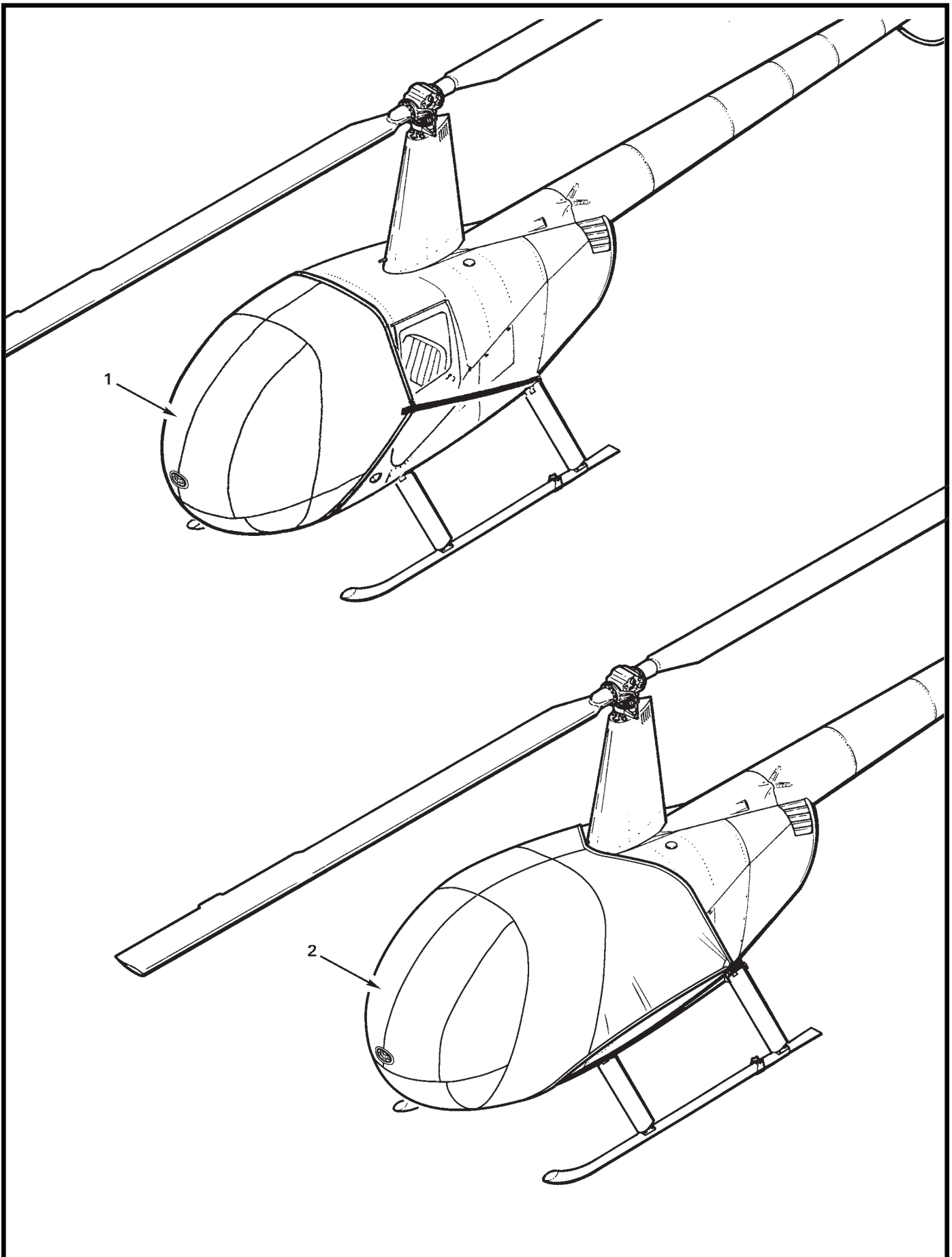

FIGURE AND INDEX NUMBER	PART NUMBER	DESCRIPTION	PARTS AVAIL	QTY PER ASSY
CABIN COVERS				
10-3-1	R44-004	Bubble Cover	X	1
2	R44-000	Full Cover (optional)	X	1
3	R44-005	Full Cover (ENG/Police ships; not shown)	X	1
NOTES				

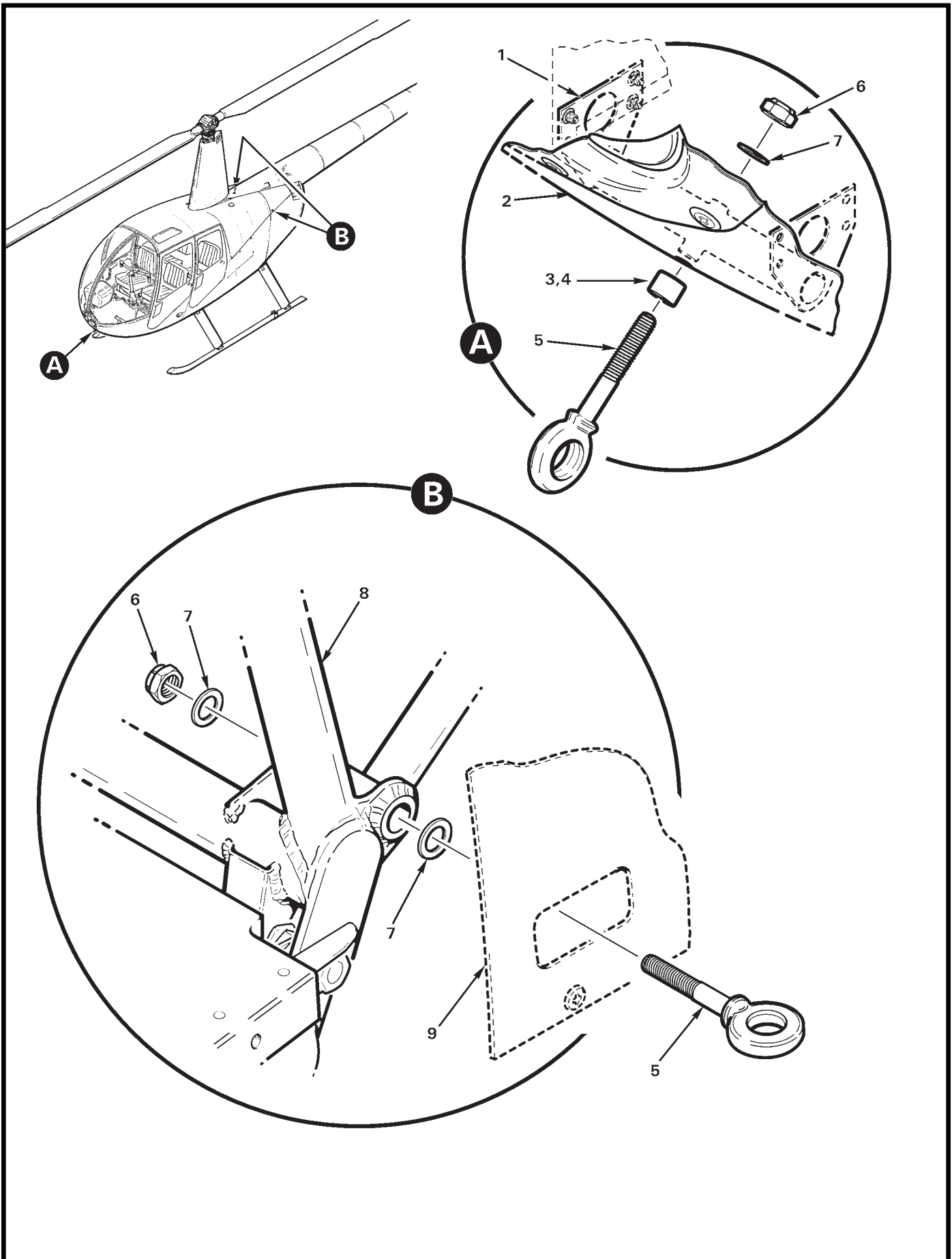

FIGURE AND INDEX NUMBER	PART NUMBER	DESCRIPTION	PARTS AVAIL	QTY PER ASSY
TIE-DOWN INSTALLATION				
10-5-1	D125-5	Weldment (Ref)		
2	C272	Chin (Ref)		
3	C130-38	Spacer (install using item 4)	X	1
4	B270-1	Sealant (2-oz tube)	X	A/R
5	A964-2	Eyebolt	X	3
6	21FKF-616	Nut	X	3
7	NAS1149F0632P	Washer	X	5
8	C020-2	Frame Assembly - Upper (Ref)		
9	C706-3	Panel (LH, Ref)		
	D040-7	Door (RH, Ref; not shown)		

NOTES

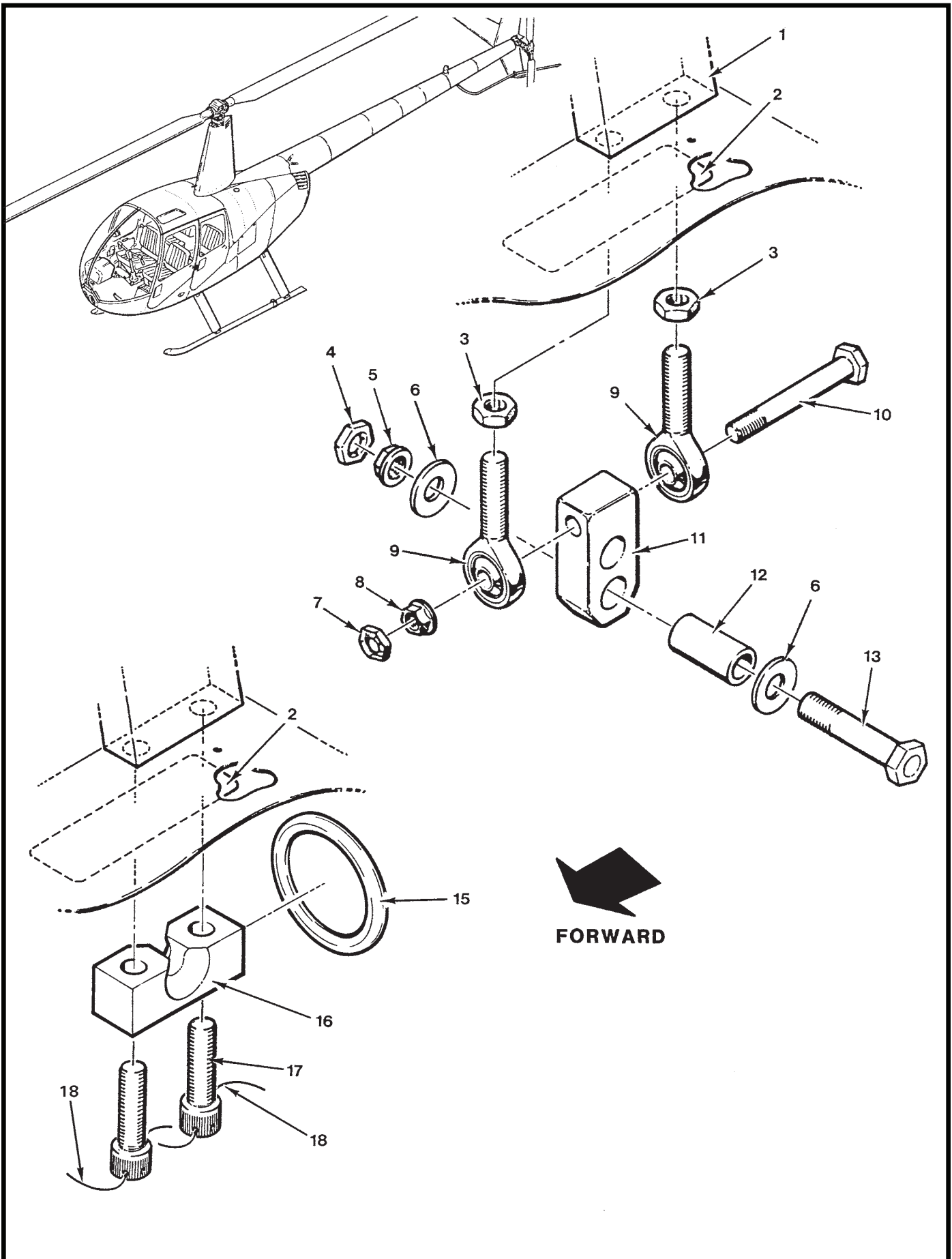

FIGURE AND INDEX NUMBER	PART NUMBER	DESCRIPTION	PARTS AVAIL	QTY PER ASSY
		HARDPOINT HINGE AND TIE-DOWN RING INSTALLATIONS		
10-7-1	D134-1	Block (Ref)		
2	C654-9	Decal	X	1
3	AN316-6R	Nut	X	2
4	B330-19	Palnut	X	1
5	MS21042L6	Nut	X	1
6	A214-1	Washer	X	2
7	B330-16	Palnut	X	1
8	MS21042L5	Nut	X	1
9	D173-1	Rod End	X	2
10	NAS6605-26	Bolt	X	1
11	D136-1	Support	X	1
12	B139-1	Journal	X	1
13	NAS6606-17	Bolt	X	1
14	KI-86	Hardpoint Hinge Installation Kit (Incl items 2 thru 13)	X	1
15	3779T84	Ring	X	1
16	B253-2	Anchor	X	1
17	NAS1351-6H20P	Screw	X	2
18	MS20995C32	0.032 in. dia. Safety Wire	X	A/R

NOTES

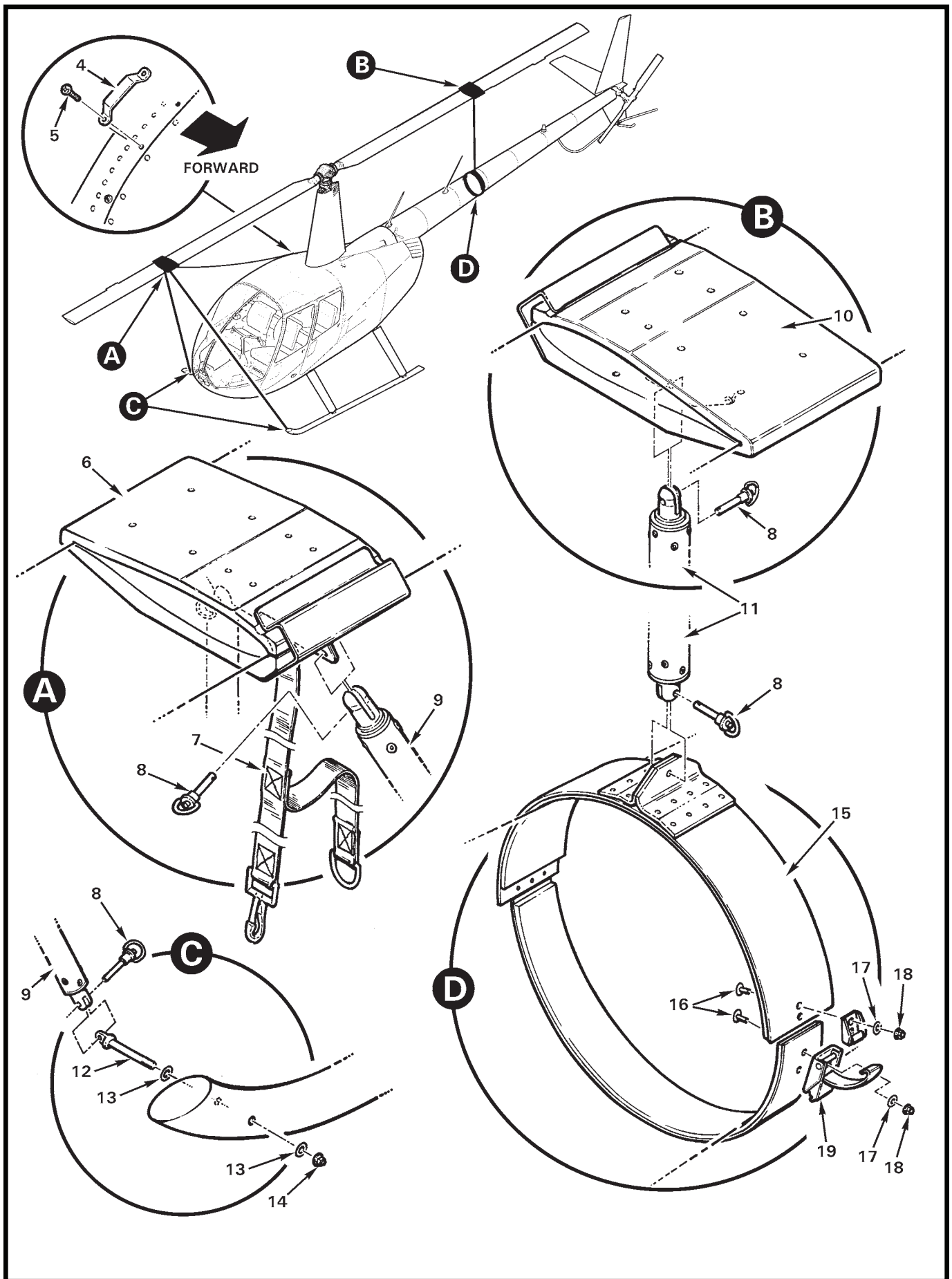

FIGURE AND INDEX NUMBER	PART NUMBER	DESCRIPTION	PARTS AVAIL	QTY PER ASSY
MAIN ROTOR BLADE SUPPORT INSTALLATION				
10-9-1	MT349-4	Main Rotor Blade Support Assembly (Incl items 2 and 3)	X	1
2	MT349-6	Support Assembly – Forward (Incl items 6, 8 [4], and 9)	X	1
3	MT349-5	Support Assembly – Aft (Incl items 8 [2], 10, 11, and 15) . . .	X	1
4	D127-2	Cleat	X	1
5	MS27039C0807	Screw	X	2
6	MT345-1	Cradle Assembly (forward blade; includes item 7)	X	1
7	MT345-5	Strap Assembly	X	1
8	92384A034	Pin	X	6
9	MT347-8	Strut Assembly (LH and RH)	X	2
10	MT345-2	Cradle Assembly (aft blade)	X	1
11	MT347-7	Strut Assembly (aft)	X	1
12	B218-2	Eye Bolt	X	2
13	NAS1149F0532P	Washer (under head)	X	2
	NAS1149F0563P	Washer (under nut)	X	2
14	B340-13	Nut	X	2
15	MT348-7	Clamp Assembly (Incl items 16 thru 19)	X	1
16	AN525-832R6	Screw	X	3
17	NAS1149FN816P	Washer	X	3
18	MS21042L08	Nut	X	3
19	97-50-215-12	Latch (includes lug)	X	1

NOTES

Intentionally Blank

CHAPTER 11

PLACARDS AND MARKINGS

<i>Figure</i>	<i>Title</i>	<i>Page</i>
11-1	Placards and Markings	11.0
11-7	Placards and Markings	11.6
11-9	Placards and Markings (Japanese)	11.8

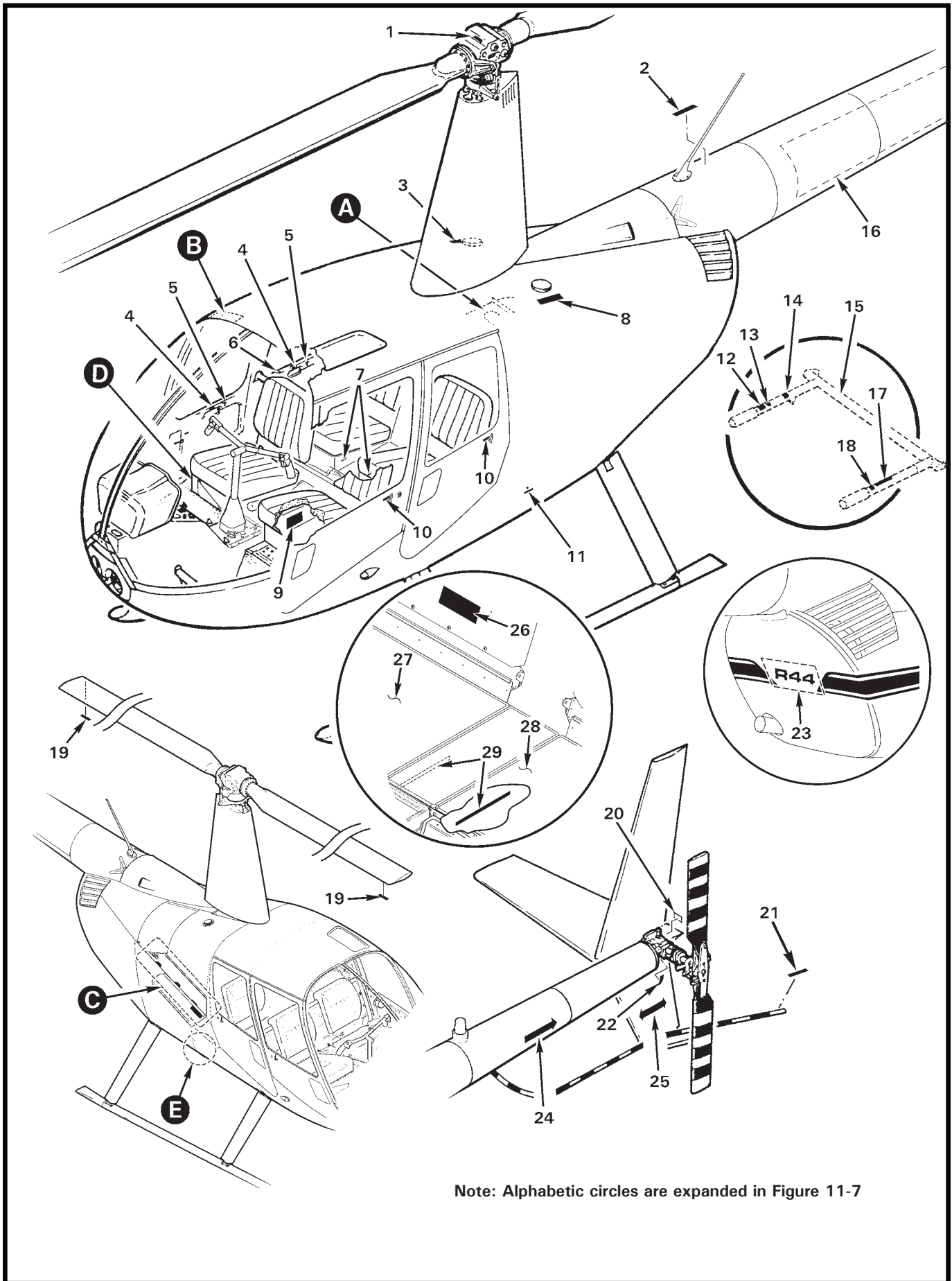

Note: Alphabetic circles are expanded in Figure 11-7

FIGURE AND INDEX NUMBER	PART NUMBER	DESCRIPTION	PARTS AVAIL	QTY PER ASSY
		PLACARDS AND MARKINGS*		
11-1-1	A654-18	Decal – “Level Here”	X	1
	B841-19	Brazilian Version	X	1
2	C654-13	Decal – Level Instructions	X	1
	B841-45	Brazilian Version	X	1
	C654-14	Decal – Level Instructions (white letters)	X	1
	B841-46	Brazilian Version (white letters)	X	1
3	C654-5	Decal – Fuel Fill Instructions (aux tank)	X	1
	B841-43	Brazilian Version	X	1
	B842-52	Chinese Version	X	1
	B830-39	Russian Version	X	1
	C654-6	Decal – Fuel Fill Instructions (aux tank; white letters)	X	1
	B841-42	Brazilian Version (white letters)	X	1
	B842-47	Chinese Version (white letters)	X	1
	B830-40	Russian Version (white letters)	X	1
4	A654-9	Decal – Door “Open” (LH)	X	2
	B841-14	Brazilian Version	X	2
	B842-12	Chinese Version	X	2
	B830-24	Russian Version	X	2
	A654-10	Decal – Door “Open” (RH)	X	2
	B841-15	Brazilian Version	X	2
	B842-13	Chinese Version	X	2
	B830-25	Russian Version	X	2
5	A654-8	Decal – Door “Latch”	X	4
	B841-13	Brazilian Version	X	4
	B842-37	Chinese Version	X	4
	B830-33	Russian Version	X	4
6	F654-18	Decal – “Push To Lock, Do Not Lock In Flight” (aft doors; replaces C654-20 [obsolete])	X	2
	B841-60	Brazilian Version	X	2
	B842-51	Chinese Version	X	2
	B830-63	Russian Version (equivalent to C654-20)	X	2
7	C654-17	Decal – “Intercom”	X	2

NOTES * Country-specific decals available only to dealers in noted country.

Continues

FIGURE AND INDEX NUMBER	PART NUMBER	DESCRIPTION	PARTS AVAIL	QTY PER ASSY	
PLACARDS AND MARKINGS* (Cont'd)					
11-1-8	C654-3	Decal – Fuel Fill Instructions (main tank)	X	1	
	B841-40	Brazilian Version	X	1	
	B842-48	Chinese Version	X	1	
	C654-4	Decal – Fuel Fill Instructions (main tank; white letters)	X	1	
	B841-41	Brazilian Version (white letters)	X	1	
	B842-49	Chinese Version (white letters)	X	1	
9	C654-1	Decal – Baggage Compartment ([1] each compartment)	X	4	
	B841-38	Brazilian Version	X	4	
	B842-46	Chinese Version	X	4	
	B830-62	Russian Version	X	4	
	G682-36	Decal – Baggage Compartment ([1] each forward compartment, R44 Cadet)	X	2	
	B830-106	Russian Version (R44 Cadet)	X	2	
	B841-70	Brazilian Version (R44 Cadet)	X	2	
	B842-56	Chinese Version (R44 Cadet)	X	2	
	10	A654-11	Decal – Door “Open” (LH, black letters)	X	2
B841-16		Brazilian Version	X	2	
B842-14		Chinese Version	X	2	
	B830-24	Russian Version	X	2	
	A654-12	Decal – Door “Open” (RH, black letters)	X	2	
	B841-17	Brazilian Version	X	2	
	B842-15	Chinese Version	X	2	
	B830-25	Russian Version	X	2	
	11	C654-7	Decal – “Static Port”	X	2
B830-67		Russian Version	X	2	
C654-8		Decal – “Static Port” (white letters)	X	2	
	B830-67	Russian Version (white letters)	X	2	
	12	A654-79	Decal – “On-Off, Throttle Open” (governor switch, ship S/N 0001 thru 9999)	X	1
		D682-8	Decal – “On-Off/Start, Throttle Open” (governor/engine starter switch, ship S/N 10001 and higher)	X	1
13	A654-6	Decal – “Throttle Open” (earlier R44s, this location)	X	1	
14	A654-7	Decal – “Friction Increase”	X	1	
15	C012-2	Collective Stick Assembly (Ref, see Figure 67-21)			

NOTES * Country-specific decals available only to dealers in noted country.

Continues

FIGURE AND INDEX NUMBER	PART NUMBER	DESCRIPTION	PARTS AVAIL	QTY PER ASSY
PLACARDS AND MARKINGS* (Cont'd)				
11-1-16	R5691	Decal – Registration Letters/Numbers	X	A/R
	R7934	Decal – Registration Letters/Numbers (stencil set, black or white)	X	1
17	A654-21	Decal – “No Stowage...”	X	2
	B841-21	Brazilian Version	X	4
	B842-42	Chinese Version	X	4
	B830-50	Russian Version	X	4
18	A654-6	Decal – “Throttle Open”	X	1
19	A654-25	Decal – “Never Pull Down”	X	2
	B841-23	Brazilian Version	X	2
	B842-18	Chinese Version	X	2
	B830-61	Russian Version	X	2
20	F654-13	Decal (tail rotor gearbox fill and oil specification)	X	1
21	C654-18	Decal – “No Hand Hold”	X	1
	B841-47	Brazilian Version	X	1
	B830-85	Russian Version	X	1
22	F110-2	Telatemp (temperature recorder, 140° – 190°F)	X	1
23	R8216	Decal – “R44” (aft cowling, stencil)	X	1
24	A654-3	Decal – “Danger”	X	2
	B841-39	Brazilian Version	X	2
	B842-21	Chinese Version	X	2
	B830-23	Russian Version	X	2
25	C654-2	Decal – “Danger”	X	2
	B841-12	Brazilian Version	X	2
	B842-11	Chinese Version	X	2
	B830-22	Russian Version	X	2
26	G682-34**	Decal – “DO NOT OCCUPY...” (RH and LH; aft loading instructions, R44 Cadet)	X	1
	B830-104**	Russian Version (R44 Cadet)	X	1
	B841-68**	Brazilian Version (R44 Cadet)	X	1
	B842-54**	Chinese Version (R44 Cadet)	X	1
27	C703-2**	Cover Assembly (Ref; RH aft compartment)		
28	C703-1**	Cover Assembly (Ref; LH aft compartment)		

NOTES * Country-specific decals available only to dealers in noted country.

** Ship S/N 30001 and subsequent. See also Figure 94-3.

Continues

FIGURE AND INDEX NUMBER	PART NUMBER	DESCRIPTION	PARTS AVAIL	QTY PER ASSY
PLACARDS AND MARKINGS* (Cont'd)				
11-1-29	G682-35**	Decal – “Compartment Load Limit...” (R44 Cadet)	X	2
	B830-105**	Russian Version (R44 Cadet)	X	1
	B841-69**	Brazilian Version (R44 Cadet)	X	1
	B842-55**	Chinese Version (R44 Cadet)	X	1
30	R44RAVENI	R44 Raven I Fuel Tank Stencil (not shown)	X	A/R
31	R44RAVENII	R44 Raven II Fuel Tank Stencil (not shown)	X	A/R
32	R44CADET	R44 Cadet Fuel Tank Stencil (not shown)	X	A/R

NOTES * Country-specific decals available only to dealers in noted country.
 ** Ship S/N 30001 and subsequent. See also Figure 94-3.

Intentionally Blank

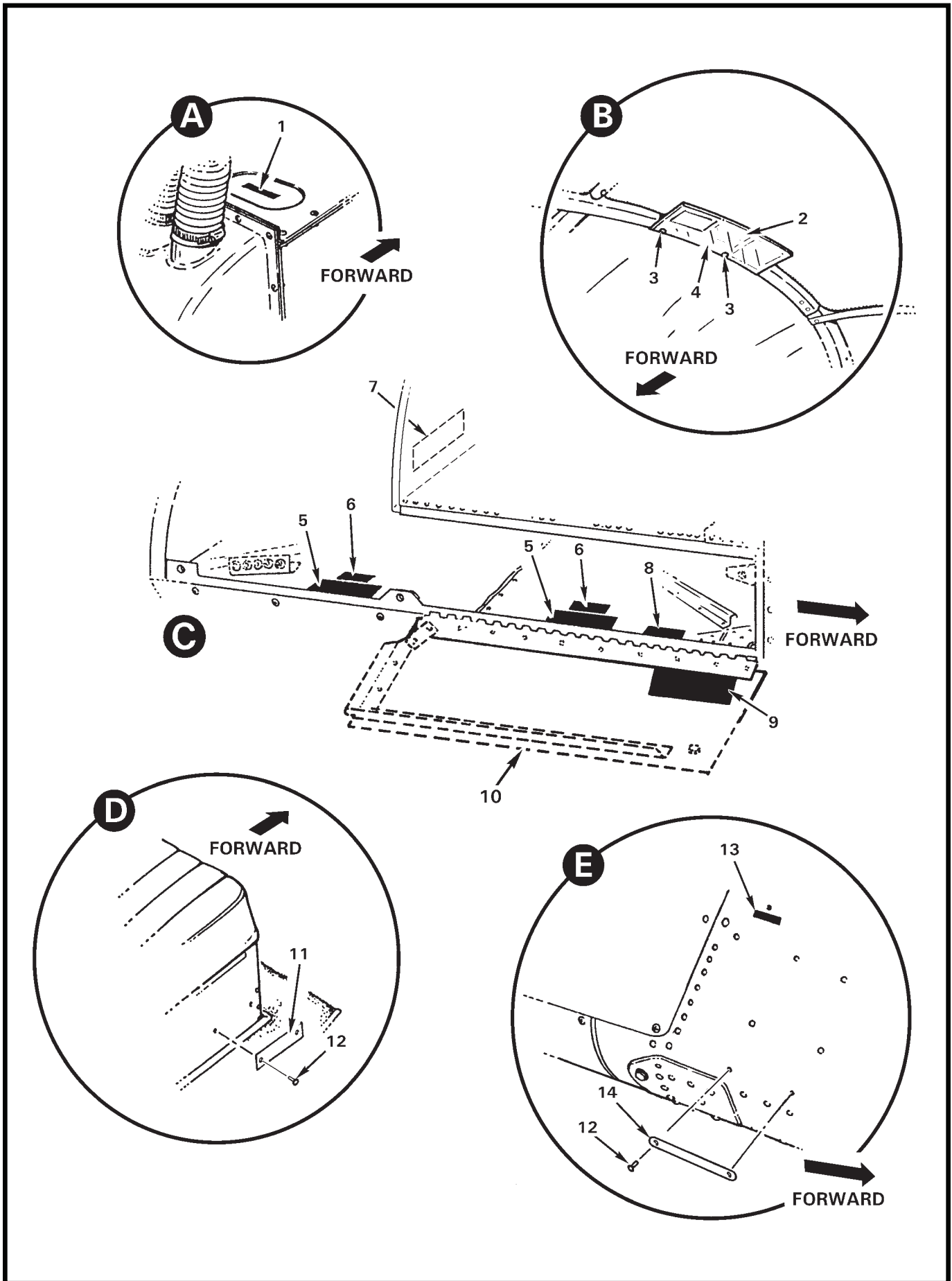

FIGURE AND INDEX NUMBER	PART NUMBER	DESCRIPTION	PARTS AVAIL	QTY PER ASSY
		PLACARDS AND MARKINGS*		
11-7-1	A654-38	Decal – “Push to Open”	X	1
	B841-25	Brazilian Version	X	1
	B830-23	Russian Version	X	1
2	C654-15**	Decal – Flight Limitations (Astro/Raven, altitude in feet; for Clipper)	X	1
	D682-10**	Decal – Flight Limitations (ship S/N 0001 thru 9999; altitude in meters; approved for Russian version)	X	1
	D682-14**	Decal – Flight Limitations (Raven II, altitude in feet; for Clipper II)	X	1
	D682-16**	Decal – Flight Limitations (ship S/N 10001 and higher; altitude in meters; approved for Russian version)	X	1
3	B204-1	Rivet (blind)	X	2
4	A725-3**	Mount	X	1
5	A654-21	Decal – “No Stowage”	X	2
	B841-21	Brazilian Version	X	2
	B842-42	Chinese Version	X	2
	B830-50	Russian Version	X	2
6	A654-19	Decal – “No Step”	X	2
	B841-20	Brazilian Version	X	2
	B830-41	Russian Version	X	2
7	F654-13	Decal (hydraulic reservoir, main/tail rotor gearbox fill and oil specification)	X	1
	B841-58	Brazilian Version	X	1
8	A654-30	Decal – “Step Here”	X	1
	B841-24	Brazilian Version	X	1
	B830-42	Russian Version	X	1
9	A654-93	Decal (fuel drain instructions)	X	1
	B830-56	Russian Version	X	2
10	D042-4	Door Assembly (Ref)		
11	A754-1	Patent Plate	O	1
12	MS20470AD3	Rivet	X	2
13	C654-7	Decal – “Static Port”	X	2
	C654-8	Decal – “Static Port” (white letters)	X	2
	B830-67	Russian Version (light or dark ships)	X	2
14	C672-1	Data Plate (S/N 0001 thru 9999, except 1140, R44)	O	1
		Data Plate (S/N 30001 and subsequent, R44 Cadet)	O	1
	C672-2	Data Plate (S/N 1140, and 10001 thru 29999, R44 II)	O	1

NOTES * Country-specific decals available only to dealers in noted country.
 ** For earlier R44s.

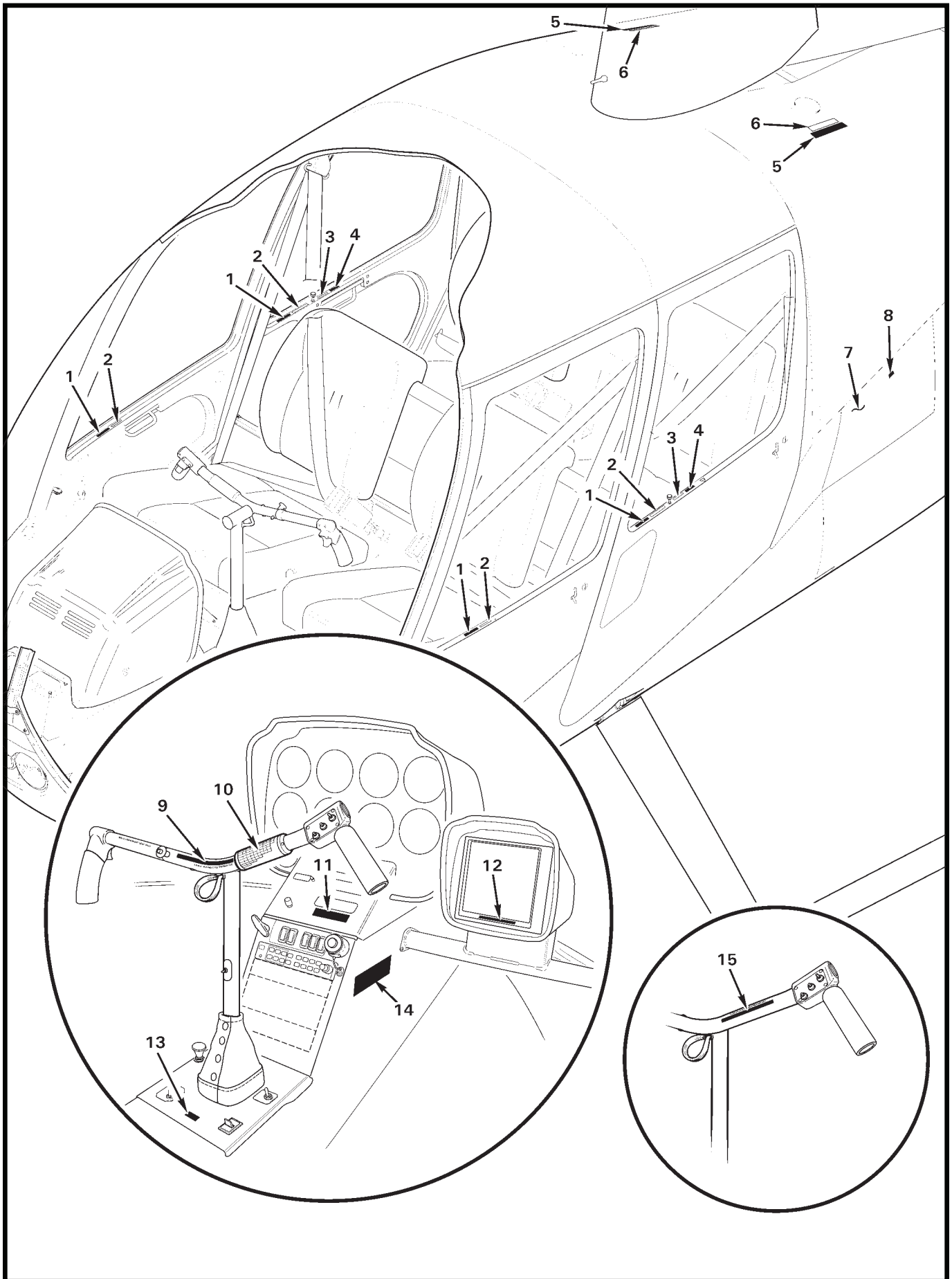

FIGURE AND INDEX NUMBER	PART NUMBER	DESCRIPTION	PARTS AVAIL	QTY PER ASSY
PLACARDS AND MARKINGS (JAPANESE)*				
11-9-1	B840-25	Decal – “TO CLOSE SLIDE HANDLE...”(Japanese version of item 2)	X	4
2	A654-9	Decal – “OPEN” (Ref; LH doors)		
	A654-10	Decal – “OPEN” (Ref; RH doors)		
3	F654-18	Decal – “PUSH TO LOCK/DO NOT LOCK IN FLIGHT” (Ref)		
4	B840-26	Decal – Door Locking Instructions (Japanese version of item 3)		
5	B840-14	Decal – Fuel Grade (Japanese version of item 6; white lettering)	X	2
	B840-15	Decal – Fuel Grade (Japanese version of item 6)	X	2
6	C654-3	Decal – Fuel Grade (Ref)		
	C654-4	Decal – Fuel Grade (Ref)		
7	C380-5	Door (Ref)		
8	B840-21	Decal – Engine Oil (white lettering)	X	A/R
	B840-22	Decal – Engine Oil	X	A/R
9	B840-20	Decal – Low-G Pushovers Prohibited (Japanese version)	X	1
10	G725-2	Tube (Ref; for ships with flight limitations placard located on cyclic grip)		
11	B840-28	Decal (white strobe light procedures)	X	A/R
12	B840-23	Decal – This GPS is Approved for VFR Only (Japanese version)	X	1
13	A654-17	Decal – “NO SMOKING” (Ref)		
14	B840-17	Decal – Flight Limitations (Japanese version)	X	1
15	B840-19	Decal – Low-G Pushovers Prohibited (Japanese version; for ships without item 10 installed)	X	1

NOTES * Country-specific decals available only to dealers in noted country.

Intentionally Blank

CHAPTER 12

SERVICING

<i>Figure</i>	<i>Title</i>	<i>Page</i>
12-1	Lubricants	12.1

Intentionally Blank

FIGURE AND INDEX NUMBER	PART NUMBER	DESCRIPTION	PARTS AVAIL	QTY PER ASSY
LUBRICANTS				
12-1-1	A257-1	Grease – Moly Grease 101	X	A/R
2	A257-2	Gear Oil – 201 (SAE 90; 1-gal container)	X	A/R
	A257-2LT	Gear Oil – 201 (SAE 90; 1-lt/qt container)	X	A/R
3	A257-3	Grease – Aeroshell 14 (MIL-G-25537; 14-oz container)	X	A/R
4	A257-4	Automatic Transmission Fluid [ATF] (Dexron III)	X	A/R
5	A257-5	Grease – Sta-Lube 3120 (water-resistant)	X	A/R
		Grease – Lubrimatic 11402 (water-resistant)	X	A/R
6	A257-6	Grease – Fuelube (fuel-resistant)	X	A/R
		Grease – EZ Turn (fuel-resistant)	X	A/R
7	A257-7	Dry Film Lube – Lubri-Kote Type A1040CR	X	A/R
8	A257-8	Rubber Lube – International P-80	X	A/R
9	A257-9	Anti-Seize – Silver Grade	X	A/R
10	A257-10	Substitute A257-16		
11	A257-12	Grease – Mobilgrease 28 (MIL-PRF-81322; 13.7-oz container)	X	A/R
	A257-12.1oz	Grease – Mobilgrease 28 (MIL-PRF-81322; 1-oz container) . . .	X	A/R
12	A257-15	Hydraulic Fluid (MIL-PRF-5606)	X	A/R
13	A257-16	Engine Oil (SAE 20W-50, mineral oil for engine break-in)	X	A/R
14	A257-18	O-Ring Lube – Dow Corning no. 55	X	A/R
15	A257-19	Valve Lube & Sealant Compound – Dow Corning no. 111	X	A/R
16	A257-20	PAG Oil – 3420025-049 Daphne Hermetic PR	X	A/R
		PAG Oil – 3420025-067 Nissan Type R	X	A/R
17	A257-21	Petrolatum Lube – P-16 (Panef Corporation)	X	A/R

NOTES

Intentionally Blank

CHAPTER 18

TRACK AND BALANCE

<i>Figure</i>	<i>Title</i>	<i>Page</i>
18-1	TEC ACES Balancing System	18.0
18-3	TEC ACES Balancing System	18.2
18-5	Chadwick-Helmuth Balancing System	18.4

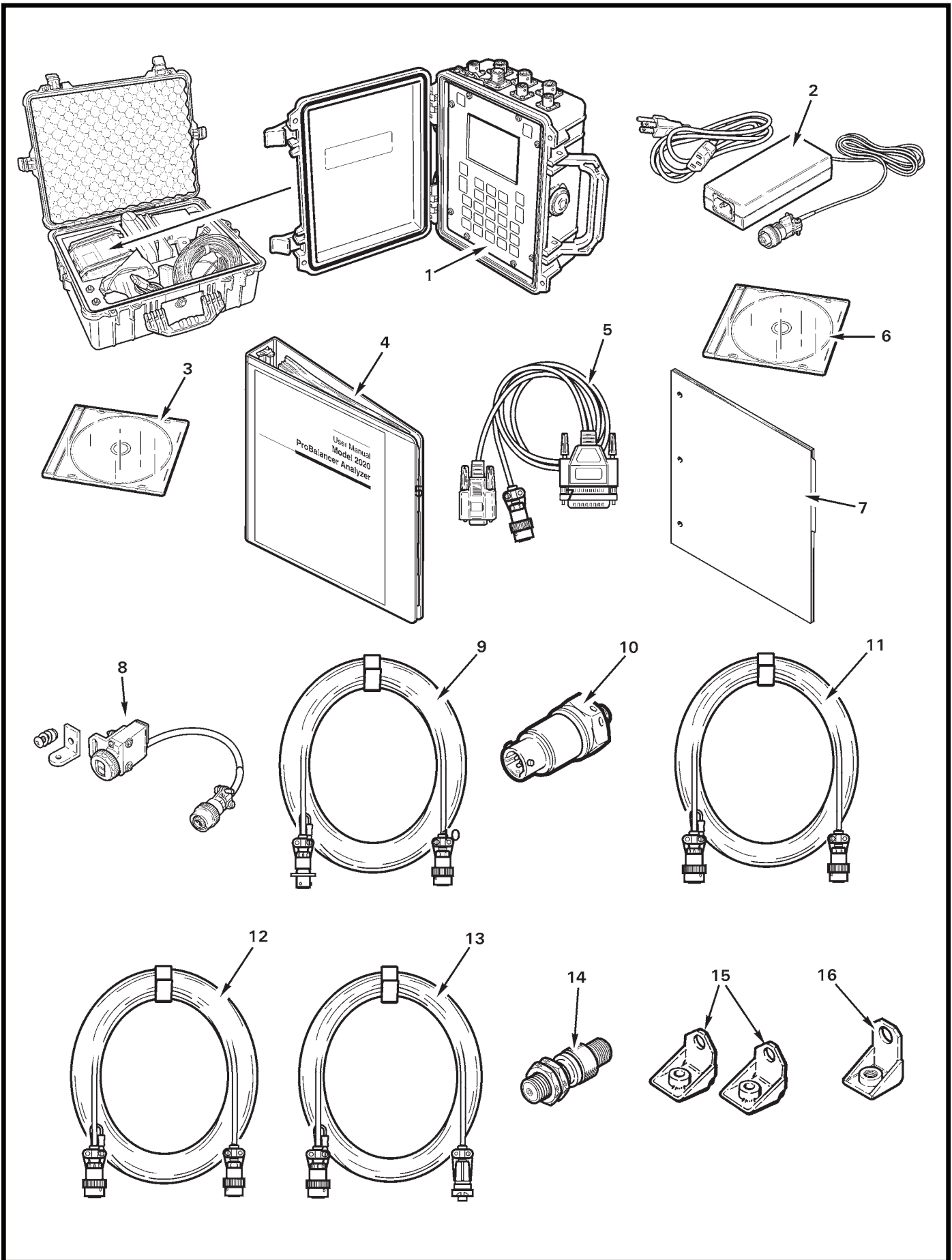

FIGURE AND INDEX NUMBER	PART NUMBER	DESCRIPTION	PARTS AVAIL	QTY PER ASSY
TEC ACES BALANCING SYSTEM				
18-1-1	10-100-2020HR	Tec Aces Analyzer and Turbo Probalancing System (includes items 1 thru 16, and Figure 18-3 items 1 thru 9)	X	1
	Z2020-LGCASE KIT	Carry Case - "Aces 2020"	X	1
2	Z10-320-4043-110V	Charger - NiMH Battery (110V)	X	1
3	75-900-0193D	DVD - "Aces 2020"	X	1
4	75-900-2020	Manual - "Aces 2020" User's Manual	X	1
5	10-320-0157	Cable - "Aces 2020" (6 ft)	X	1
6	10-700-0102	Software - "Avtrend Bronze"	X	1
7	75-900-2026	Manual - "Avtrend Bronze" User's Manual	X	1
8	10-100-1773	Tachometer - Optical Photocell	X	1
9	10-320-0126	Cable - Tachometer (50 ft)	X	1
10	69-100-0075	Sensor - Vibration Transducer	X	2
11	10-320-0162	Cable - Sensor (25 ft)	X	1
12	10-320-0163	Cable - Sensor (50 ft)	X	1
13	10-320-0052	Cable - Magnetic pickup (25 ft)	X	1
14	75-900-0187	Sensor - Magnetic pickup	X	1
15	22-420-0035	Mount - 1/4 in. hole	X	2
16	22-430-0036	Mount - 5/16 in. hole	X	1

NOTES

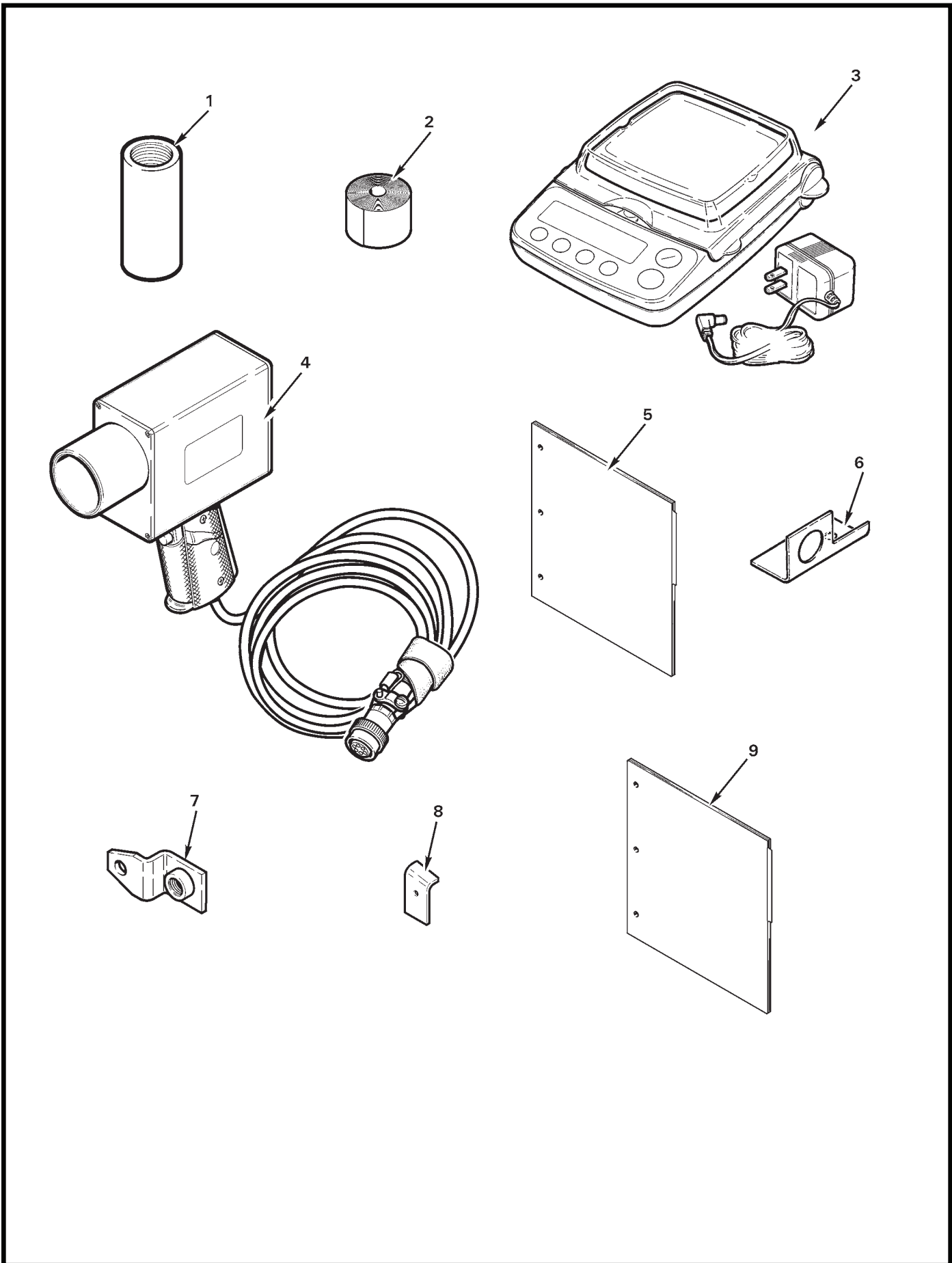

FIGURE AND INDEX NUMBER	PART NUMBER	DESCRIPTION	PARTS AVAIL	QTY PER ASSY
TEC ACES BALANCING SYSTEM*				
18-3-1	22-430-0096	Sun Shield - Tachometer	X	1
2	10-400-0176	Reflective Tape (10-ft roll)	X	1
3	75-900-0507	Scale	X	1
4	75-900-0542	Tracker - Optical	X	1
5	—	Manual - Optical Tracker (Supplement)	X	1
6	22-430-0066	Mount - Multipurpose	X	1
7	22-430-0037	Mount - Sensor	X	1
8	22-430-0082	Interrupter	X	1
9	75-900-2022	Manual - EPS Supplement	X	1

NOTES * See also Figure 18-1.

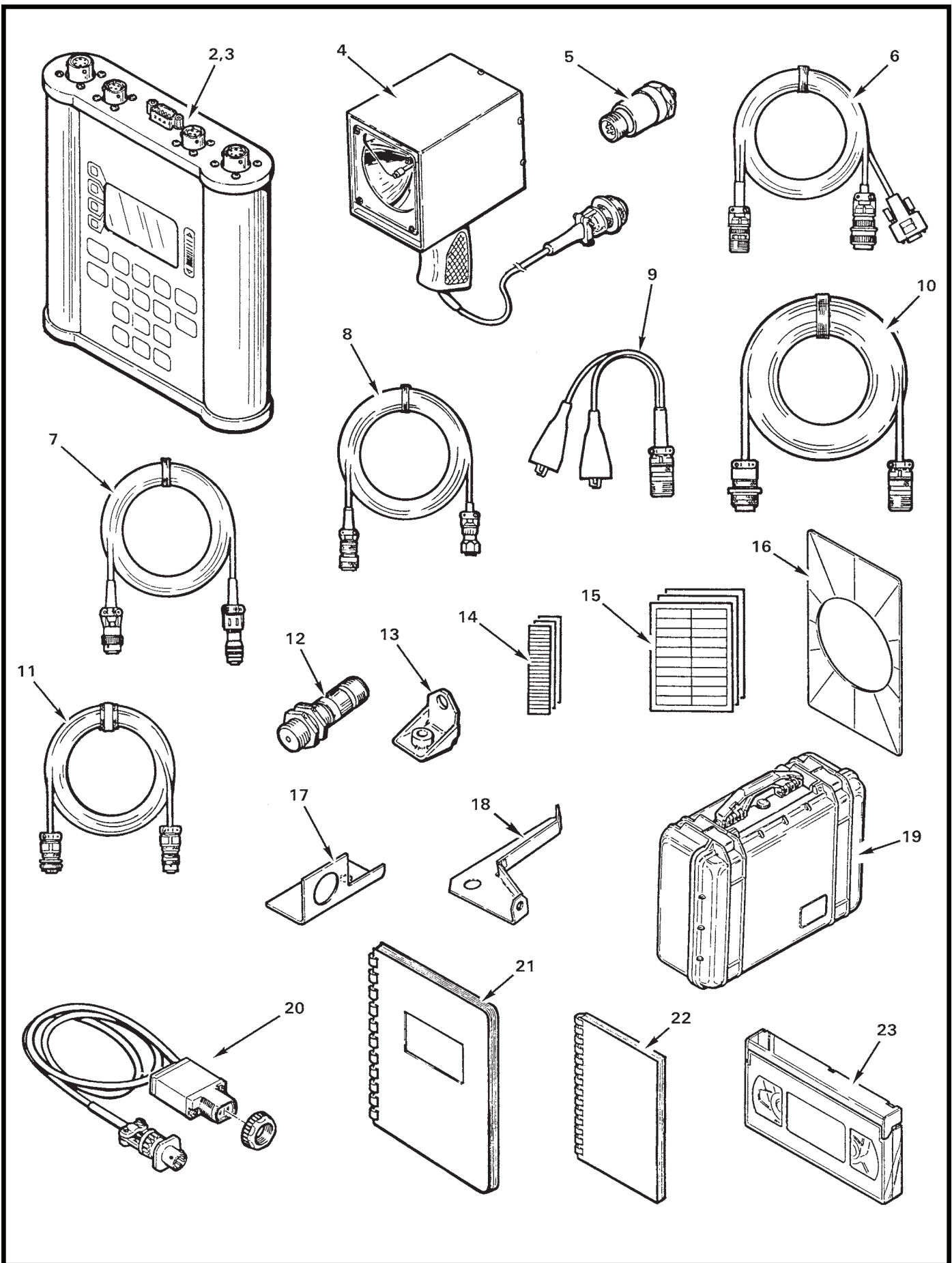

FIGURE AND INDEX NUMBER	PART NUMBER	DESCRIPTION	PARTS AVAIL	QTY PER ASSY
CHADWICK-HELMUTH BALANCING SYSTEM				
18-5-1	KI-68	Chadwick-Helmuth Balancing System (Incl items 2, and 4 thru 23) .	X	1
	KI-68A	Chadwick-Helmuth Balancing System (Incl items 3 thru 23) . . .	X	1
2	13590*	Balancer - Vibrex 2000	O	1
3	14990*	Balancer - Vibrex 2000 Plus (includes spectrum viewer)	O	1
4	8620*	Strobex Tracker (135M-12)	O	1
5	901-7310*	Velocimeter	X	1
6	13797*	Cable Assembly - Vibrex 2000/Strobex	O	1
7	11247-50*	Cable Assembly - Optical (50 feet)	O	1
8	902-11210-50*	Cable Assembly - Velo (50 feet)	O	1
9	902-3140-5*	Cable Assembly - DC (with battery clips)	O	1
10	902-3529*	Cable Assembly - DC (50-foot extension)	O	1
11	902-10808-25*	Cable Assembly - Magnetic Pickup (25 feet)	O	1
12	906-5876*	Magnetic Pickup (3030)	X	1
13	904-3382A*	Bracket - Transducer (0.28 HL SS)	X	1
14	907-3300*	Target Patch Set (sheet of 20)	X	1
15	907-4270-1*	Tip Targets (laminated, sheet of 20)	X	1
16	13871*	Protractor - Vibrex 2000 (T/R)	O	1
17	10423A	Bracket - Vibrex 2000 (generic)	O	1
18	MT121-1	Bracket - Magnetic Pickup	X	1
19	13842*	Carrying Case - Vibrex 2000	O	1
20	12900*	Photocell	O	1
21	9076*	Operation/Maintenance Manual	O	1
22	13841-6*	User Guide - Vibrex 2000/2000 Plus	O	1
23	610-453*	Video - Vibrex 2000	O	1

NOTES * Chadwick-Helmuth part no.

Intentionally Blank

CHAPTER 21
ENVIRONMENT CONTROL

<i>Figure</i>	<i>Title</i>	<i>Page</i>
21-1	Cabin Heat and Vent Controls	21.0
21-5	Air Conditioning – Compressor Assembly Installation	21.4
21-9	Air Conditioning – Compressor Drive Cartridge Assembly	21.8
21-11	Air Conditioning – Compressor Cutoff Switch	21.10
21-13	Air Conditioning – Condenser Installation	21.12
21-15	Air Conditioning – Evaporator Assembly Installation	21.14
21-19	Air Conditioning – Evaporator Assembly	21.18
21-23	Air Conditioning – Evaporator Drain Tube Installation	21.22
21-25	Air Conditioning – Evaporator Lines Installation	21.24
21-27	Air Conditioning – Line Assembly Installation	21.26
21-29	Air Conditioning – Line Assembly Installation	21.28
21-31	Air Conditioning – Duct Assembly Installation	21.30
21-33	Air Conditioning – Duct Assembly Components	21.32
21-37	Cabin Heater – System Installation	21.36
21-41	Cabin Heater – Splitter Installation	21.40

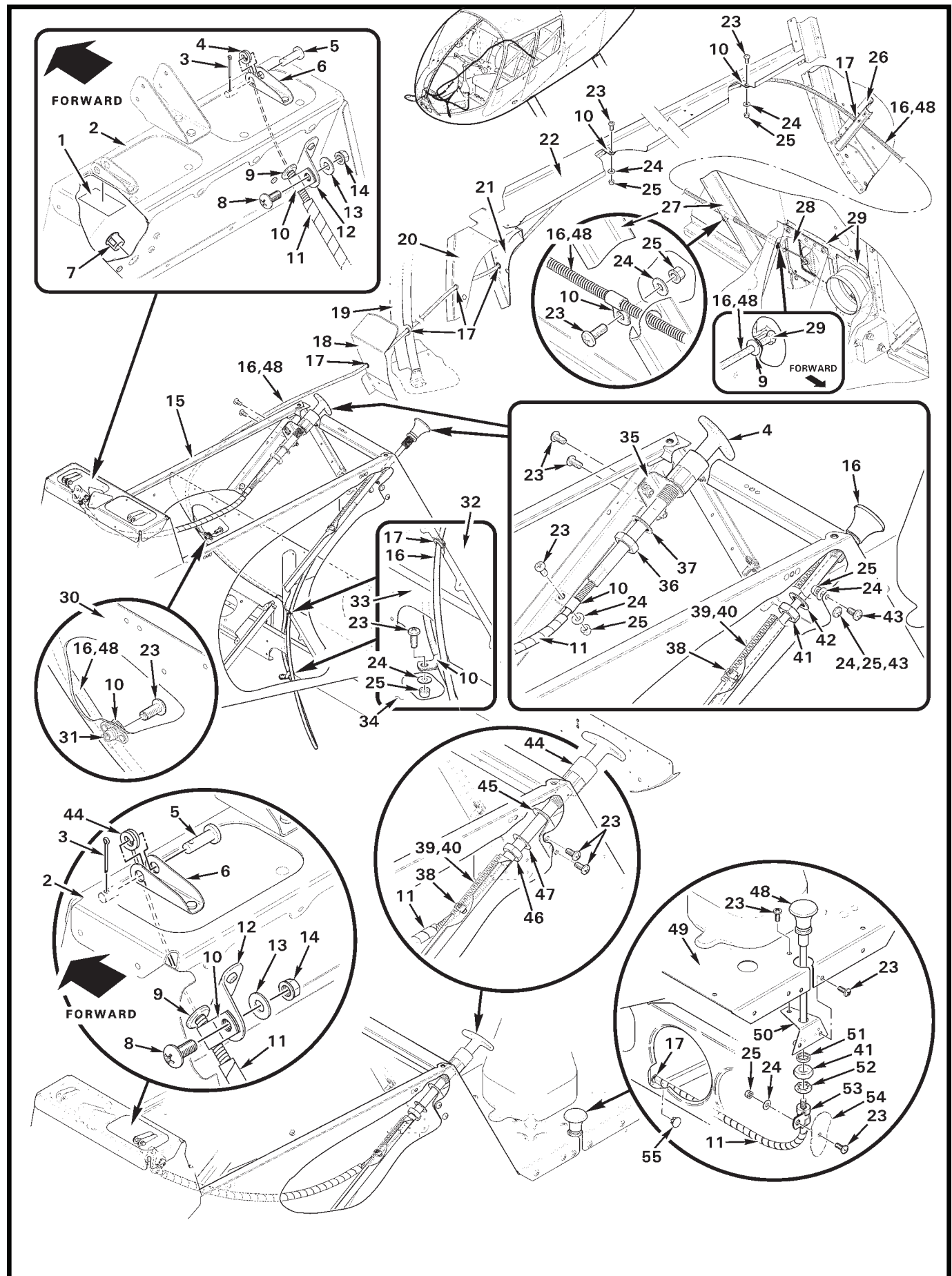

FIGURE AND INDEX NUMBER	PART NUMBER	DESCRIPTION	PARTS AVAIL	QTY PER ASSY
CABIN HEAT AND VENT CONTROLS				
21-1-1	A701-1	Tape (aluminum; covers unused slot, LH and RH)	X	A/R
2	C062-1	Vent Box Assembly (Ref)		
3	MS24665-73	Cotter Pin	X	2
4	C522-5	Control – Cabin Air Vent (Ship S/N 0001 thru 9999, and 30001 and subsequent; RH location. Includes items 36 and 37.)	X	1
5	MS20392-2C13	Pin	X	2
6	A523-4	Channel (Ref)		
7	2613	Hole Plug (opposite items 4 or 44, LH or RH)	X	1
8	MS27039C1-06	Screw	X	1
9	MS35489-4	Grommet	X	1
10	AN742-3	Clamp	X	7
11	B161-4	Spirap	X	A/R
12	A523-6	Angle (Ref)		
13	NAS1149F0332P	Washer	X	1
14	D210-3	Nut	X	2
15	C033-1	Lower Console Assembly (Ref)		
16	A522-8	Control – Cabin Heat (Ship S/N 0001 thru 9999, and 30001 and subsequent; this location. Includes items 41 and 42.) . . .	X	1
17	NAS557-3A	Grommet	X	9
18	C390-2	Panel (RH, Ref)		
19	C403-4	Channel (RH, Ref)		
20	C350-2	Panel (RH, Ref)		
21	C296-4	Bulkhead (RH, Ref)		
22	C287-2	Panel (RH, Ref)		
23	MS27039C0806	Screw	X	9
24	NAS1149FN816P	Washer	X	9
25	MS21042L08	Nut	X	7
26	C384-5	Stiffener (Ref)		
27	C372-3	Stiffener (Ref)		
28	B019-3	Valve Assembly (Ref, see Figure 21-37)		
29	B270-1	Sealant	X	A/R

NOTES

Continues

FIGURE AND INDEX NUMBER	PART NUMBER	DESCRIPTION	PARTS AVAIL	QTY PER ASSY
CABIN HEAT AND VENT CONTROLS (Cont'd)				
21-1-30	D230-2	Bulkhead (Ref)		
31	MS21069L08K	Nutplate (Ref)		
32	A371-3	Stiffener (Ref)		
33	C407-2	Beam (Ref)		
34	C272-1	Chin (Ref)		
35	C365-12	Mount (RH control)	X	1
36	—	Nut	O	1
37	—	Washer	O	1
38	MS3367-5-9	Ty-Rap	X	1
39	MS21266-1N	Grommet (install using item 40)	X	A/R
40	B270-8qt	Adhesive	X	A/R
41	—	Nut	O	1
42	—	Washer	O	1
43	MS27039C0805	Screw	X	2
44	C522-5	Control – Cabin Air Vent (ship S/N 10001 thru 29999, LH location; includes items 46 and 47.)	X	1
45	C365-13	Mount (LH control)	X	1
46	—	Nut	O	1
47	—	Washer	O	1
48	A522-8	Control – Cabin Heat (Ship S/N 10001 thru 29999 this location. Includes item 41.)	X	1
49	C444	Cover – Cyclic (Ref)		
50	C518-1	Cover Assembly	X	1
51	A130-18	Spacer	X	1
52	B330-19	Palnut	X	1
53	MS21919WDG4	Clamp	X	1
54	C293-3	Keel Panel (Fwd, LH; Ref)		
55	B209-6	Hole Plug (ship S/N 0001 thru 9999 only)	X	1

NOTES

Intentionally Blank

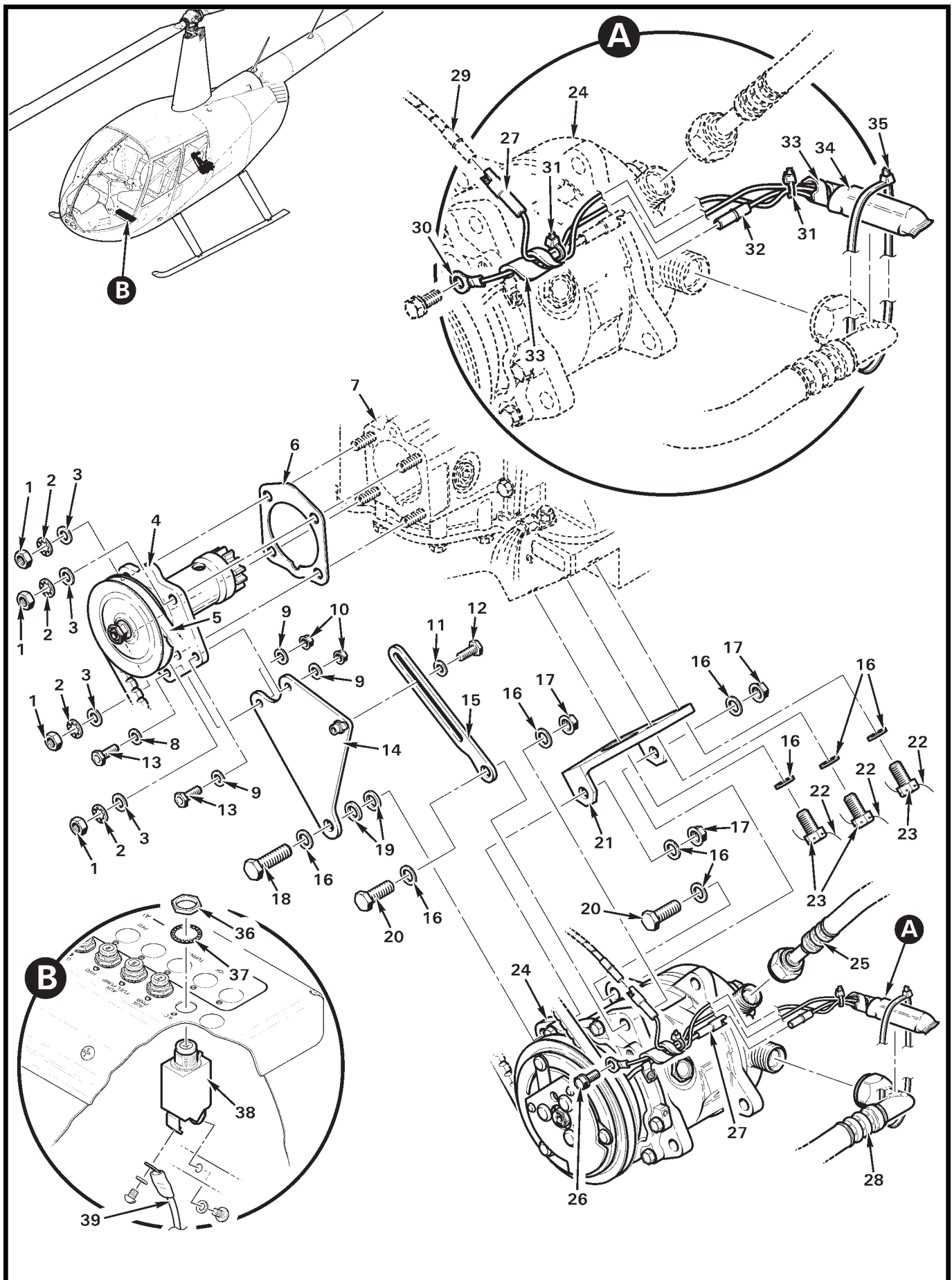

FIGURE AND INDEX NUMBER	PART NUMBER	DESCRIPTION	PARTS AVAIL	QTY PER ASSY
		AIR CONDITIONING – COMPRESSOR ASSEMBLY INSTALLATION		
21-5-1	STD-1410*	Nut	X	4
2	STD-475*	Lockwasher	X	8
3	STD-35*	Washer	X	4
4	D778-1	Cartridge Assembly – Compressor Drive (Incl items 1 thru 5 from Figure 21-9)	X	1
5	B173-4	V-Belt	X	1
6	69551*	Gasket	X	1
7	IO-540-AE1A5*	Engine (Ref; ship S/N 10001 thru 29999 [R44 II])		
	O-540-F1B5*	Engine (Ref; ship S/N 30001 and subsequent [R44 Cadet])		
8	NAS1149F0463P	Washer	X	1
9	NAS1149F0432P	Washer	X	3
10	MS21042L4	Nut	X	2
11	A141-14	Washer	X	1
12	NAS6604-4	Bolt	X	1
13	NAS6604-5	Bolt	X	2
14	D782-1	Brace Assembly	X	1
15	D782-3	Arm	X	1
16	NAS1149F0632P	Washer	X	9
17	MS21042L6	Nut	X	3
18	NAS6606-12	Bolt	X	1
19	NAS1149F0663P	Washer	X	2
20	NAS6606-8	Bolt	X	2
21	D782-4	Bracket	X	1
22	MS20995C32	0.032 in. dia. Safety Wire	X	A/R
23	D782-5	Bolt	X	3
24	D777-1	Compressor Assembly (Incl items 26, 31, 33, and 34)	X	1
25	D810-1	Line Assembly (Ref, see Figure 21-29)		
26	—	Bolt (supplied with compressor)	O	8
27	B263-10	Housing	X	1
	B263-3	Pin	X	1
28	D794-1	Hose Assembly (Ref, see Figure 21-27)		
29	C059-1823	Wire (Ref, power)		

NOTES * Lycoming part no.

Continues

FIGURE AND INDEX NUMBER	PART NUMBER	DESCRIPTION	PARTS AVAIL	QTY PER ASSY
AIR CONDITIONING – COMPRESSOR ASSEMBLY INSTALLATION (Cont'd)				
21-5-30	B260-5	Terminal	X	1
31	MS3367-4-9	Ty-Rap	X	2
32	B263-11	Housing	X	1
	B263-4	Socket	X	1
33	B161-8	Spirap	X	1
34	D799-6	Snubber Assembly (Incl items 27, 30, and 32)	X	1
35	MS3367-5-9	Ty-Rap	X	1
36	—	Nut	O	1
37	—	Lockwasher	O	1
38	B297-15	Circuit Breaker (15 amp; includes items 36 and 37)	X	1
39	-1807	Wire (Ref)		
NOTES				

Intentionally Blank

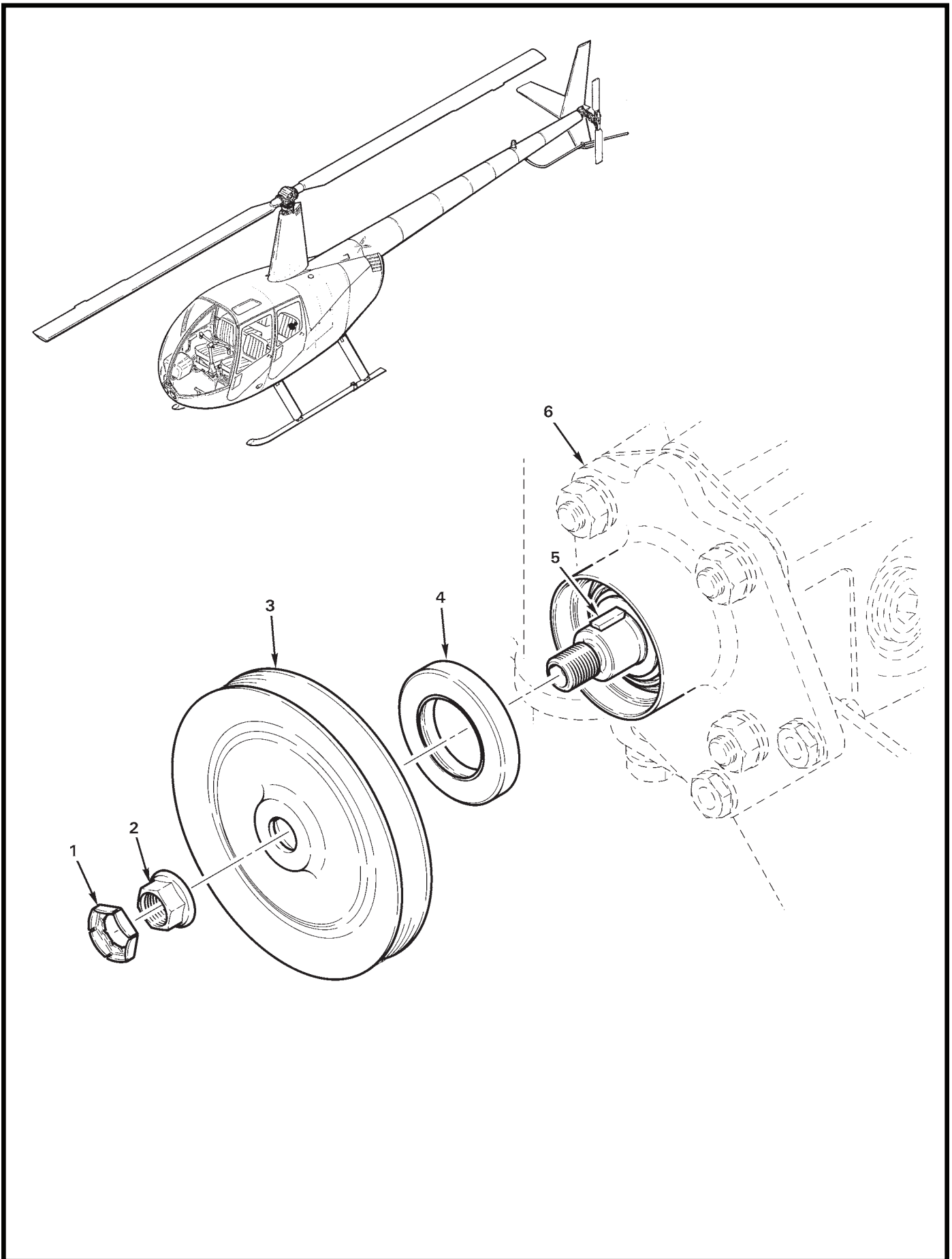

FIGURE AND INDEX NUMBER	PART NUMBER	DESCRIPTION	PARTS AVAIL	QTY PER ASSY
AIR CONDITIONING – COMPRESSOR DRIVE CARTRIDGE ASSEMBLY				
21-9-1	B330-19	Palnut	X	1
2	MS21042L6	Nut	X	1
3	D779-1	Pulley	X	1
4	A966-5	Seal	X	1
5	98525A075	Woodruff Key	X	1
6	D778-1	Cartridge Assembly – Compressor Drive	O	1
	D778-1R	Cartridge Assembly (overhaul exchange)	X	1

NOTES

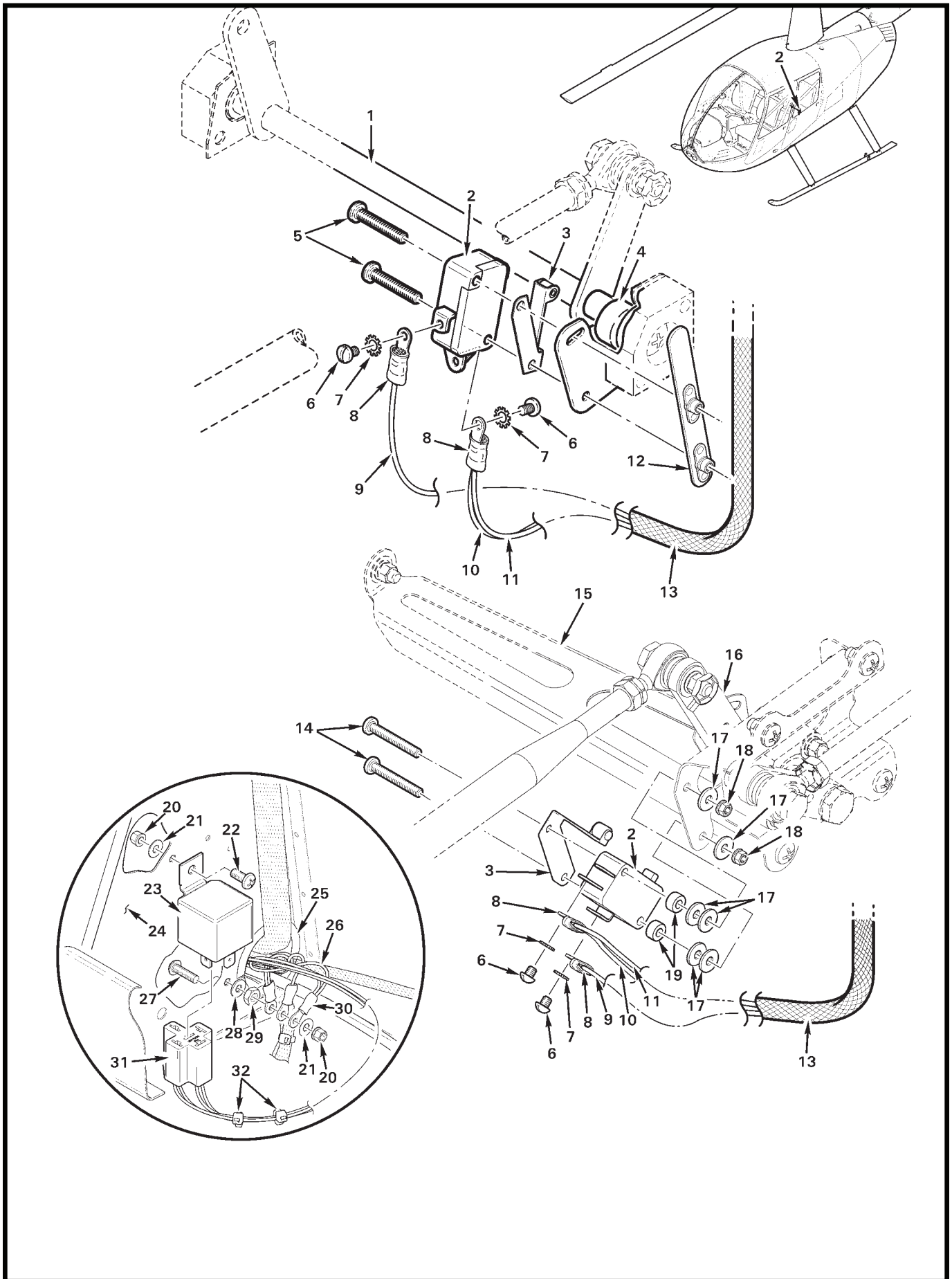

FIGURE AND INDEX NUMBER	PART NUMBER	DESCRIPTION	PARTS AVAIL	QTY PER ASSY
		AIR CONDITIONING – COMPRESSOR CUTOFF SWITCH		
21-11-1	D731-1 *	Bellcrank Assembly (Ref; forward)		
2	V3-1	Switch (Incl items 6 and 7)	X	1
3	JV-5	Actuator	X	1
4	A534-1 *	Stop	O	1
5	MS35206-219	Screw	X	2
6	—	Screw	O	2
7	—	Lockwasher	O	2
8	B260-1	Terminal	X	1
9	C859-2487	Wire (Ref; power)		
10	C859-2488	Wire (Ref; full throttle warning light)		
11	C859-2490	Wire (Ref; A/C relay, if installed)		
12	D731-11	Plate Assembly	X	1
13	B266-4	Sleeving	X	A/R
14	MS35206-220	Screw	X	2
15	C607-1 **	Support (Ref)		
16	D756-4 **	Bellcrank Assembly (Ref; aft)		
17	NAS1149FN432P	Washer	X	6
18	MS21042L04	Nut	X	2
19	A130-14	Spacer	X	2
20	MS21042L08	Nut	X	2
21	NAS1149FN816P	Washer	X	2
22	MS27039C0806	Screw	X	1
23	D260-4	Relay (air conditioning cutoff)	X	1
24	C351-1	Panel (Ref)		
25	NAS557-22A	Grommet	X	1
26	C859-2491	Wire – Ground (Ref)		
27	AN515UB8R10	Screw	X	1
28	NAS1149DN832H	Washer	X	1
29	B301-8	Nut	X	1
30	B260-3	Terminal	X	1
31	D260-6	Connector	X	1
	B262-6	Receptacle	X	4
32	MS3367-4-9	Ty-Rap	X	A/R

NOTES * Ship S/N 10001 thru 29999.
 ** Ship S/N 30001 and subsequent.

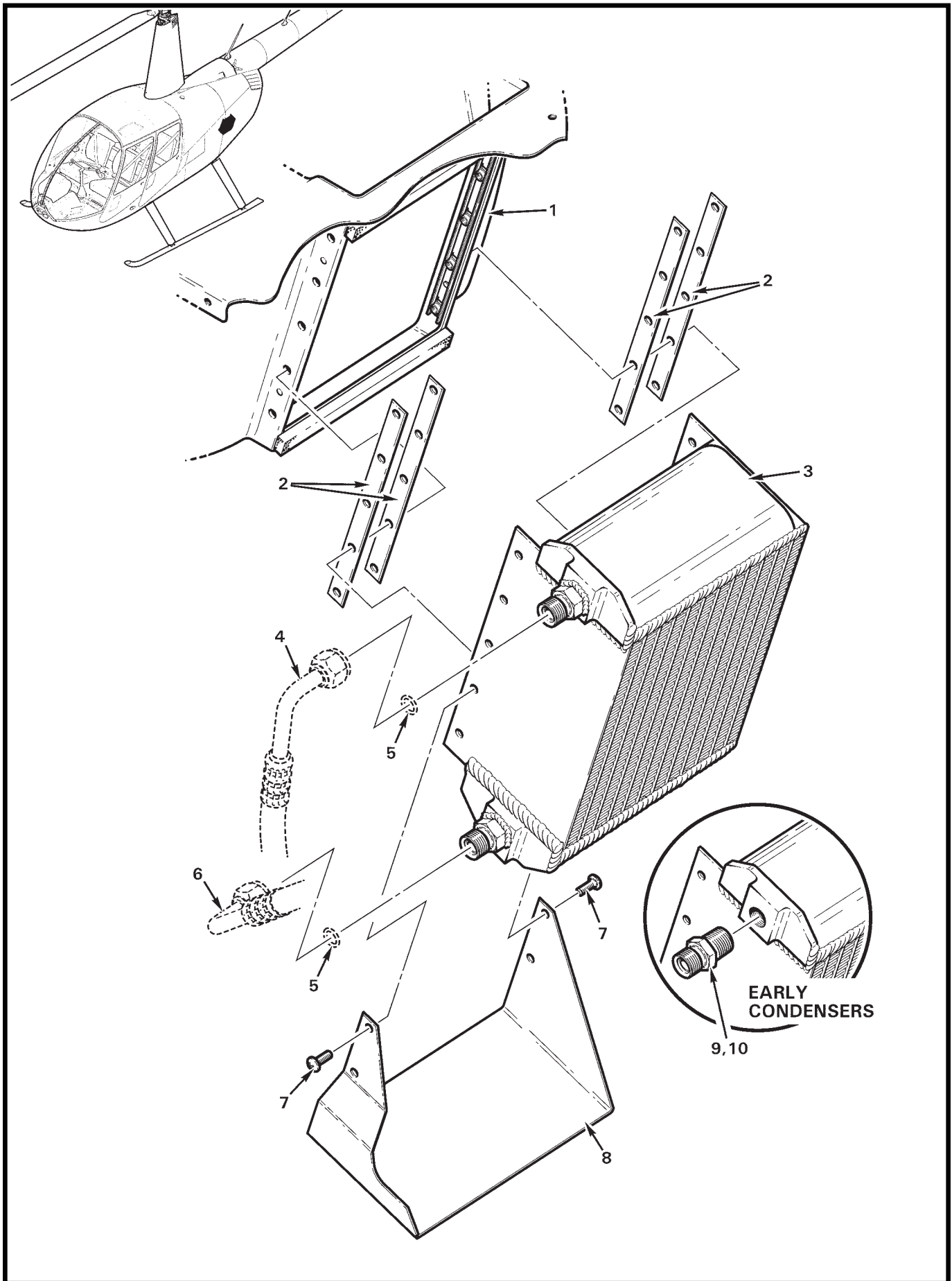
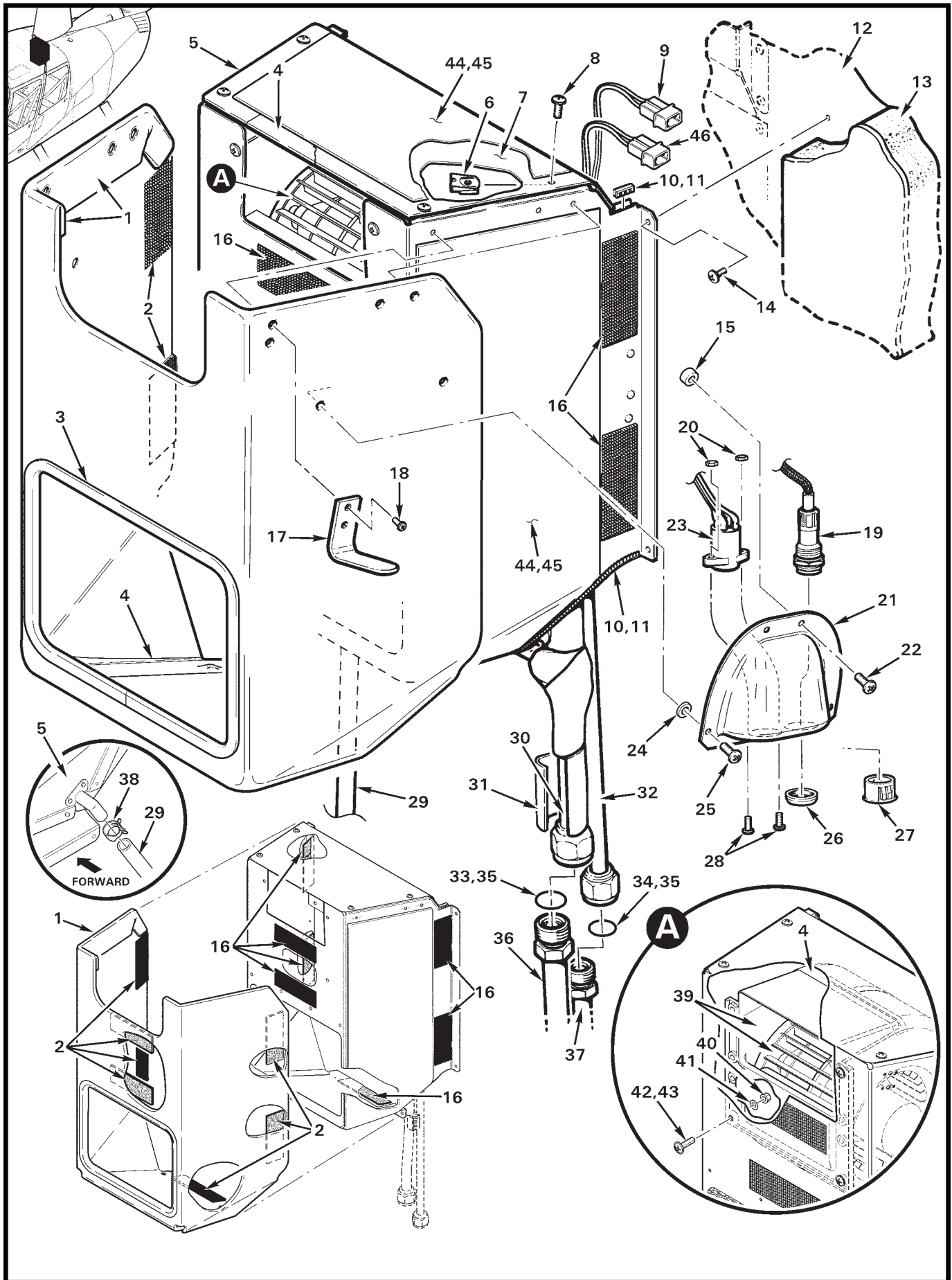

FIGURE AND INDEX NUMBER	PART NUMBER	DESCRIPTION	PARTS AVAIL	QTY PER ASSY
AIR CONDITIONING – CONDENSER INSTALLATION				
21-13-1	C236-5	Scroll – Lower (Ref, see Figure 71-29)		
2	D785-3	Shim	X	A/R
3	D783-1	Condenser	X	1
4	D810-1	Line Assembly (Ref, see Figure 21-29)		
5	24606	O-Ring (Ref, see Figure 21-27)		
6	D811-1	Line Assembly (Ref, see Figure 21-29)		
7	MS27039C1-08	Screw	X	10
8	D785-4	Shield	X	1
9	D785-1	Fitting (install using item 10)	X	2
10	B270-6	Sealant	X	A/R
NOTES				



Page 21.14 FIGURE 21-15 AIR CONDITIONING – EVAPORATOR ASSEMBLY INSTALLATION FEB 2020

FIGURE AND INDEX NUMBER	PART NUMBER	DESCRIPTION	PARTS AVAIL	QTY PER ASSY
		AIR CONDITIONING – EVAPORATOR ASSEMBLY INSTALLATION		
21-15-1	D852-1 *	Cover Assembly (includes items 2 thru 4; no holes in Cadet)	X	1
2	B175-11	Hook Tape (3.00-inch length)	X	7
3	A226-11	Trim	X	A/R
4	A701-1	Foil Tape	X	A/R
5	D798-1	Evaporator Assembly (Incl items 4, 6 thru 8, 10, 11, 29 thru 35, and 39 thru 43)	X	1
6	B162-3	Clipnut	X	6
7	D787-2	Cover	X	1
8	MS27039C0806	Screw	X	6
9	B263-12	Housing (blower)	X	1
	B263-3	Pin	X	2
10	A225-2	Grommet	X	A/R
	MS21266-1N	Grommet (earlier ships, installed using item 11)	X	A/R
11	B270-8qt	Adhesive	X	A/R
12	—	Bulkhead – Vertical (Ref)		
13	C003-18	Insulation (Ref, R44 Raven II; see Figure 25-25)		
	C003-25	Insulation (Ref, R44 Cadet; see Figure 25-25)		
14	MS27039C0805	Screw	X	10
15	A130-21	Spacer	X	6
16	B175-12	Loop Tape (3.00-inch length)	X	7
17	A752-1 **	Angle – Headset Holder	X	2
18	NAS1352-04-8P	Screw	X	4
19	D746-3	Wire Harness (for use with BOSE headset option)	X	2
	D746-1	Wire Harness (for use with BOSE headset option; earlier aircraft)	O	2
20	B330-2 **	Palnut	X	2
21	C710-4 **	Cover	X	2
22	MS27039C0811 **	Screw	X	6
23	TJT-120 **	Jack (Ref)	X	2
24	C130-24 **	Spacer	X	2
25	MS27039C0809 **	Screw	X	2
26	— **	Nut (Ref)		

NOTES * Please specify color (blue, charcoal, gray, or tan).
 ** Ship S/N 10001 thru 29999 with A/C installed.

Continues

FIGURE AND INDEX NUMBER	PART NUMBER	DESCRIPTION	PARTS AVAIL	QTY PER ASSY
AIR CONDITIONING – EVAPORATOR ASSEMBLY INSTALLATION (Cont'd)				
21-15-27	2653*	Hole Plug (for use when item 19 is not installed)	X	2
28	MS35206-215*	Screw	X	4
29	A729-38	Tube	X	1
30	D793-1	Line Assembly (Ref)		
31	5541K11	Pipe Wrap	X	A/R
32	D792-1	Line Assembly (Ref)		
33	24608	O-Ring (install using item 35)	X	1
34	24606	O-Ring (install using item 35)	X	1
35	A257-20	Oil – Pag	X	A/R
36	D793-2	Line Assembly (Ref)		
37	D792-2	Line Assembly (Ref)		
38	D277-9	Clamp	X	1
	MS20995C32	0.032 in. dia. Safety Wire (earlier ships)	X	A/R
39	D791-4	Fan Assembly (Incl items 4 and 9)	X	1
40	MS21042L08	Nut	X	4
41	NAS620-8L	Washer	X	4
42	AN525-832R9	Screw (installed using item 43 on earlier aircraft)	X	4
43	B270-4	Sealant	X	A/R
44	B298-102	Foam	X	A/R
45	B270-8qt	Adhesive	X	A/R
46	B263-32	Housing (freeze switch)	X	1
	B263-1	Pin	X	2

NOTES * Ship S/N 10001 thru 29999 with A/C installed.

Intentionally Blank

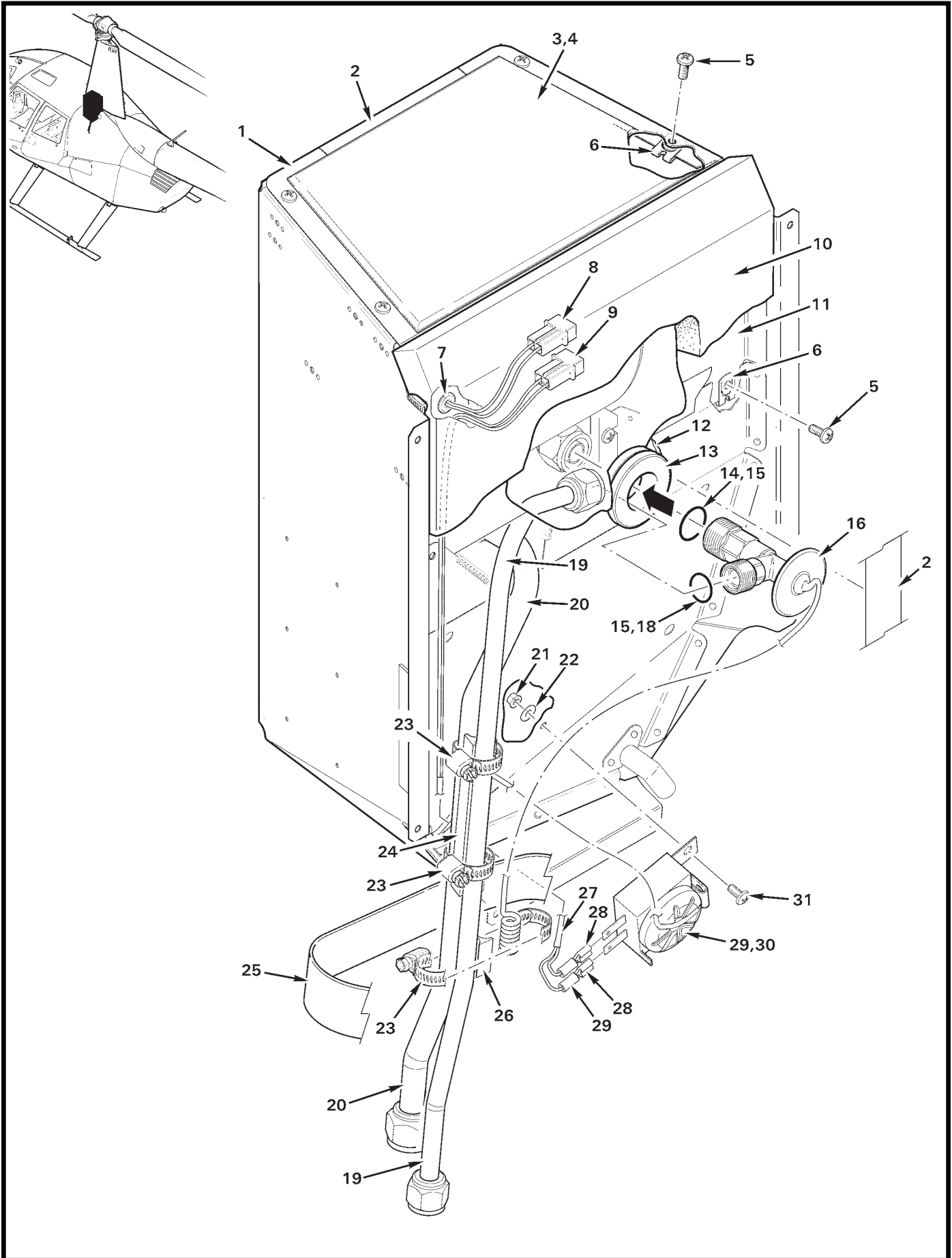

FIGURE AND INDEX NUMBER	PART NUMBER	DESCRIPTION	PARTS AVAIL	QTY PER ASSY
AIR CONDITIONING - EVAPORATOR ASSEMBLY				
21-19-1	D798-1	Evaporator Assembly (Incl items 2 thru 8, 10 thru 26, 30, and 31) .	X	1
2	A701-1	Foil Tape	X	A/R
3	B298-102	Foam (install using item 4)	X	A/R
4	B270-14	Adhesive	X	A/R
5	MS27039C0806	Screw	X	9
6	B162-3	Clipnut	X	9
7	MS35489-4	Grommet	X	1
8	B263-12	Housing (red/black wires, to fan assembly)	X	1
	B263-3	Pin	X	2
9	B263-32	Housing (white wires, to item 29)	X	1
	B263-1	Pin	X	2
10	D812-1	Insulation (install using item 4)	X	A/R
11	D787-2	Cover	X	1
12	B270-13	Sealant (translucent)	X	A/R
13	MS35489-22	Grommet	X	1
14	24608	O-Ring (install using item 15)	X	1
15	A257-20	Oil - Pag	X	A/R
16	G778-1	Thermal Expansion Valve (TXV; install using item 17 to seal nuts on items 19 and 20)	X	1
17	B270-21	Protectant	X	A/R
18	24606	O-Ring (install using item 15)	X	1
19	D792-1	Line Assembly (Ref)		
20	D793-1	Line Assembly (Ref)		
21	MS21042L08	Nut	X	1
22	NAS1149FN816P	Washer	X	1
23	B277-8	Clamp	X	3
24	D785-7	Cradle	X	1
25	5541K11	Pipe Wrap	X	A/R
26	D785-2	Cradle	X	1
27	B158-3	Heat Shrink	X	A/R
28	B262-4	Receptacle	X	2
29	71R3100	Switch (freeze)	X	1

NOTES

Continues

FIGURE AND INDEX NUMBER	PART NUMBER	DESCRIPTION	PARTS AVAIL	QTY PER ASSY
		AIR CONDITIONING - EVAPORATOR ASSEMBLY (Cont'd)		
21-19-30	D799-1	Switch Assembly - Freeze (Incl items 9, and 27 thru 29)	X	1
31	MS27039C0805	Screw	X	1
NOTES				

Intentionally Blank

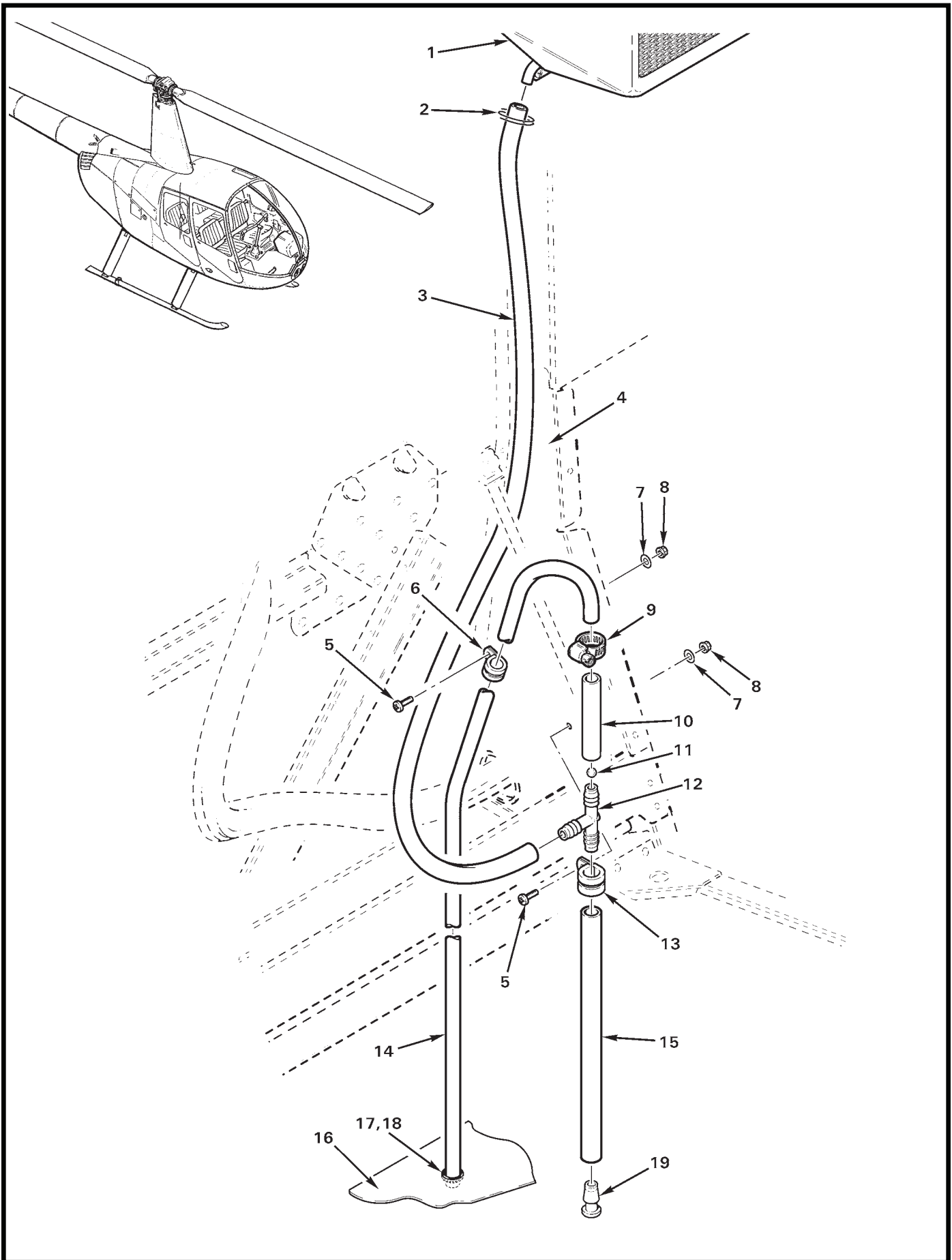

FIGURE AND INDEX NUMBER	PART NUMBER	DESCRIPTION	PARTS AVAIL	QTY PER ASSY
AIR CONDITIONING - EVAPORATOR DRAIN TUBE INSTALLATION				
21-23-1	D798-1	Evaporator Assembly (Ref, see Figures 21-15 and 21-19)		
2	MS20995C32	0.032 in. dia. Safety Wire	X	A/R
3	A729-38	Tube	X	1
4	C351-2	Brace - RH (Ref)		
5	MS27039C0807	Screw	X	2
6	MS21919WDG6	Clamp	X	1
7	NAS1149FN816P	Washer	X	2
8	MS21042L08	Nut	X	2
9	B277-4	Clamp	X	1
10	A729-40	Tube	X	1
11	9529K16	Ball	X	1
12	A457-1	Tee	X	1
13	MS21919WDG8	Clamp	X	1
14	D789-5	Tube (one-piece)	X	1
15	A729-39	Tube - Sediment	X	1
16	—	Belly - (Ref)		
17	NAS557-6A	Grommet (install using item 18)	X	1
18	B270-1	Sealant (2-oz tube)	X	A/R
19	A457-3	Plug	X	1

NOTES

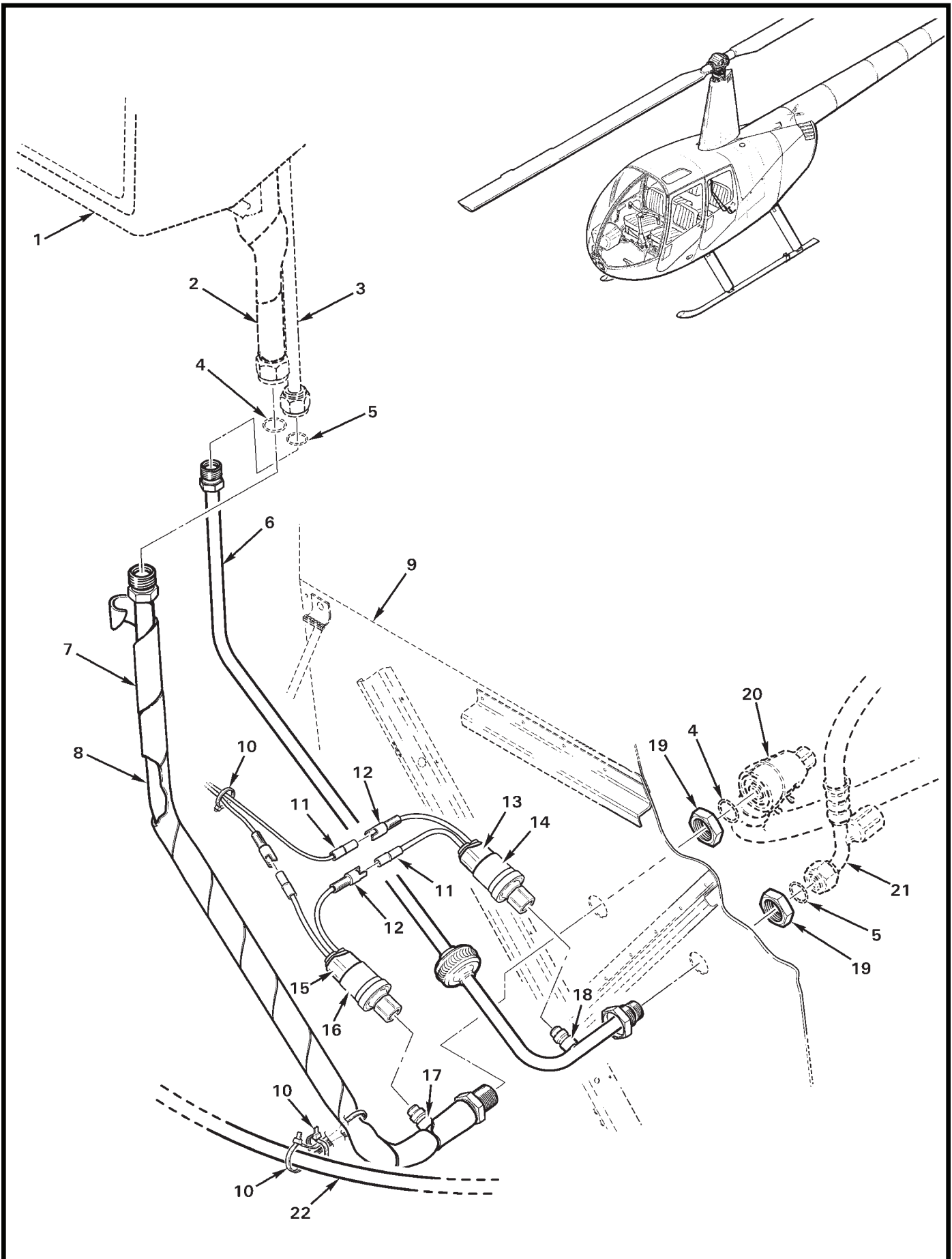

FIGURE AND INDEX NUMBER	PART NUMBER	DESCRIPTION	PARTS AVAIL	QTY PER ASSY
AIR CONDITIONING – EVAPORATOR LINES INSTALLATION				
21-25-1	D798-1	Evaporator Assembly (Ref)		
2	D793-1	Line Assembly (Ref)		
3	D792-1	Line Assembly (Ref)		
4	24608	O-Ring (Ref)		
5	24606	O-Ring (Ref)		
6	D792-2	Line Assembly (Incl item 18)	X	1
7	5541K11	Pipe Wrap	X	A/R
8	D793-2	Line Assembly (Incl items 7 and 17)	X	1
9	C233-1	Firewall – Vertical (Ref)		
10	MS3367-4-9	Ty-Rap	X	2
11	B263-11	Housing	X	2
	B263-4	Socket	X	2
12	B263-10	Housing	X	2
	B263-3	Pin	X	2
13	B158-512	Heat Shrink (red, 0.375-inch dia.)	X	A/R
14	D799-2	Switch Assembly – High-Pressure (Incl items 11 thru 13) . . .	X	1
15	B158-412	Heat Shrink (blue, 0.375-inch dia.)	X	A/R
16	D799-3	Switch Assembly – Low-Pressure (Incl items 11, 12, and 15)	X	1
17	B158-408	Heat Shrink (blue, 0.25-inch dia.)	X	A/R
18	B158-508	Heat Shrink (red, 0.25-inch dia.)	X	A/R
19	AN924-8D	Nut	X	2
20	D794-1	Hose Assembly (Ref, see Figure 21-27)		
21	D811-1	Line Assembly (Ref)		
22	—	Static Pressure Line (Ref)		
23	B330-19	Palnut (for compressor pulley, not shown; see Figure 21-9) . .	X	1
24	KI-201	Air Conditioning System Upgrade Kit (For R44s with D799-2 and -3 switches, revision “J” and prior. Includes items 10, 14, 16 thru 18, and 23.)	X	1

NOTES

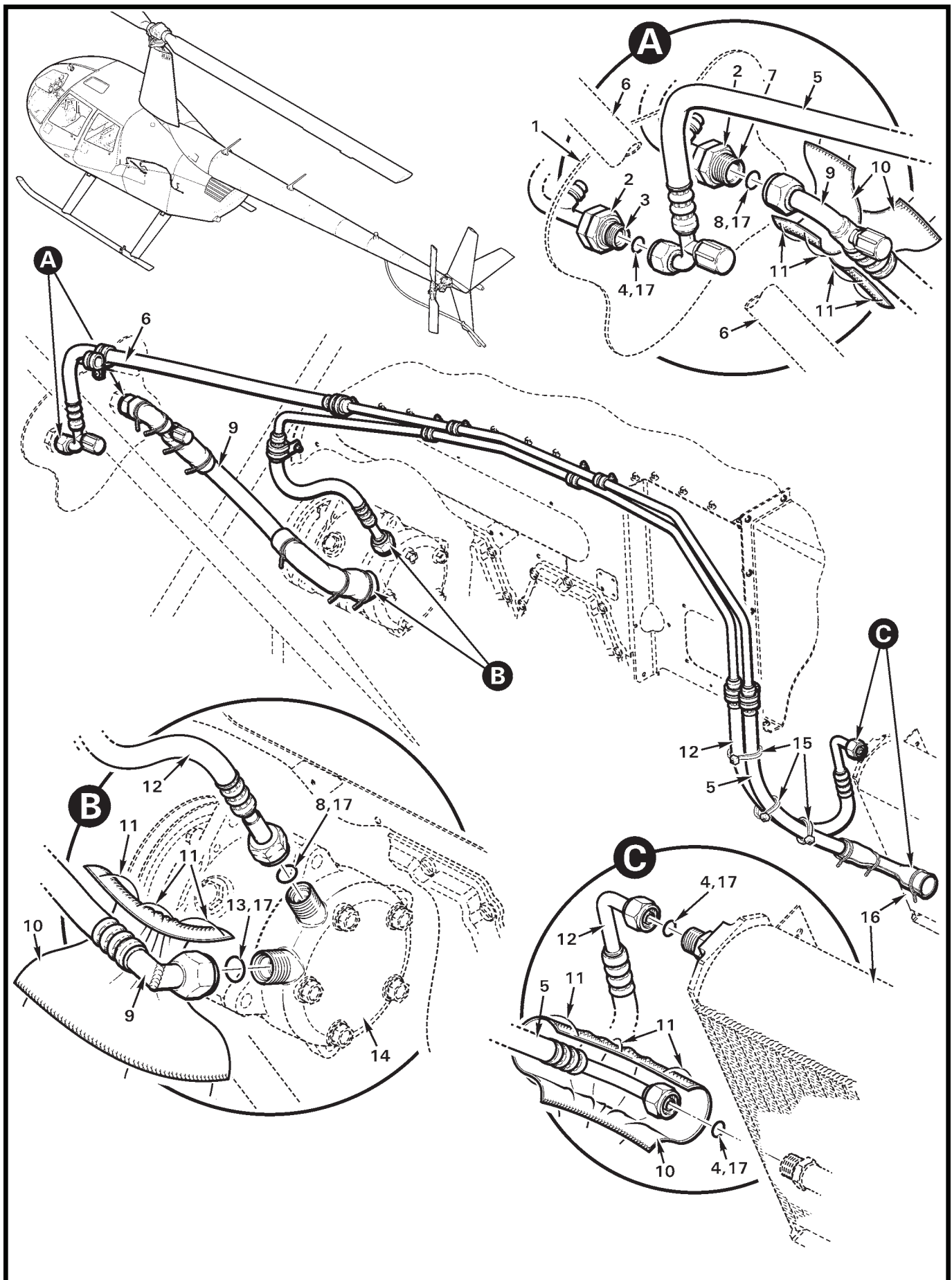

FIGURE AND INDEX NUMBER	PART NUMBER	DESCRIPTION	PARTS AVAIL	QTY PER ASSY
AIR CONDITIONING – LINE ASSEMBLY INSTALLATION				
21-27-1	C233-1	Firewall – Vertical (Ref)		
2	AN924-8D	Nut (Ref, see Figure 21-25)		
3	D792-2	Line Assembly (Ref, see Figure 21-25)		
4	24606	O-Ring (install using item 17)	X	3
5	D811-1	Line Assembly (Ref, see Figure 21-29)		
	D811-2	Line Assembly (Ref, not shown; see Figure 21-29)		
6	C046	Frame – Lower (LH, Ref)		
7	D793-2	Line Assembly (Ref, see Figure 21-25)		
8	24608	O-Ring (install using item 17)	X	2
9	D794-1	Hose Assembly	X	1
10	AE272-3	Sleeve	X	A/R
11	MS20995C32	0.032 in. dia. Safety Wire	X	A/R
12	D810-1	Line Assembly (Ref, see Figure 21-29)		
13	24610	O-Ring (install using item 17)	X	1
14	D777-1	Compressor Assembly (Ref, see Figure 21-5)		
15	MS3367-5-9	Ty-Rap	X	1
16	D783-1	Condenser (Ref, see Figure 21-13)		
17	A257-20	Oil – Pag (lubricate o-ring and threads)	X	A/R

NOTES

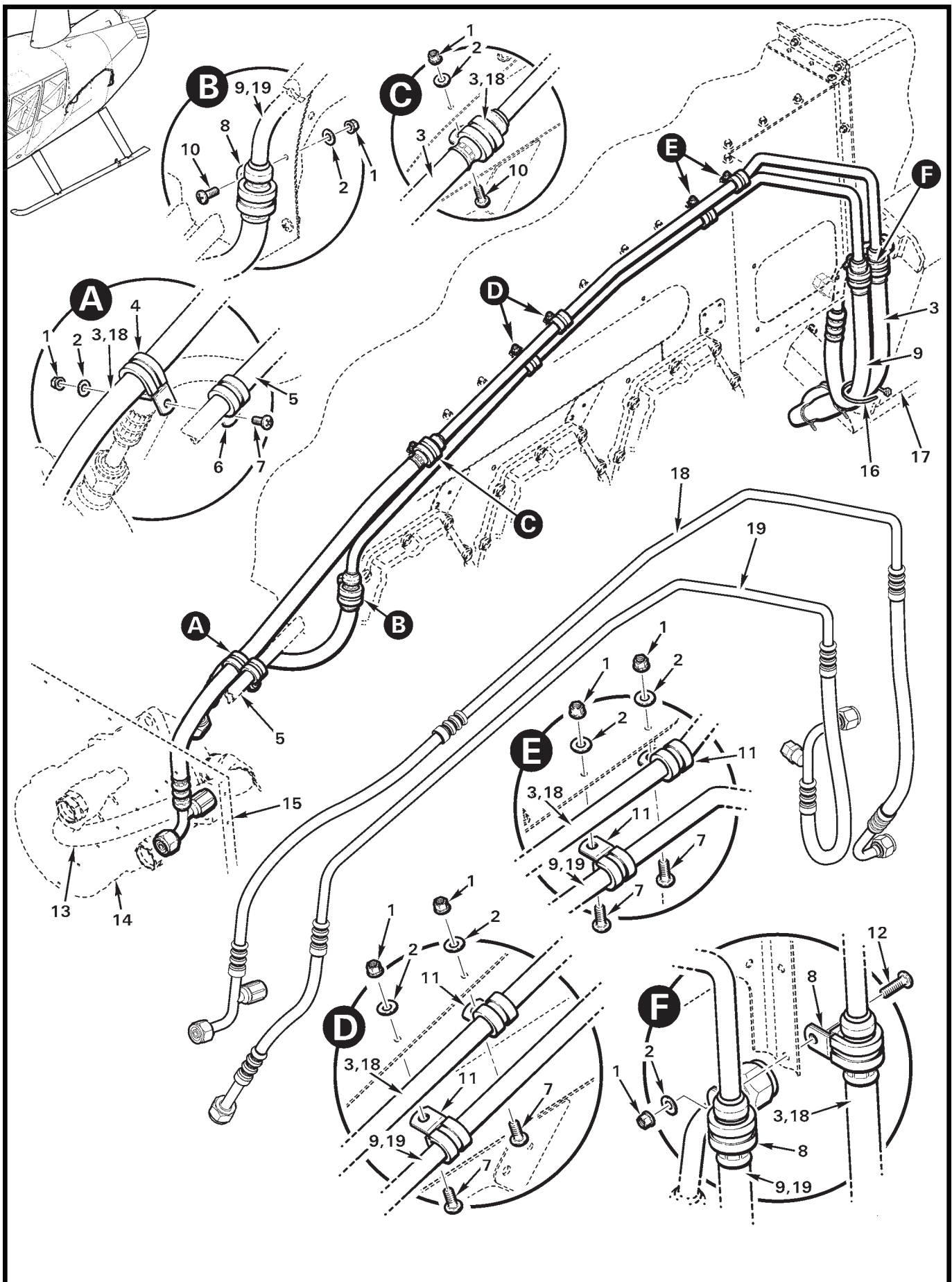

FIGURE AND INDEX NUMBER	PART NUMBER	DESCRIPTION	PARTS AVAIL	QTY PER ASSY
AIR CONDITIONING – LINE ASSEMBLY INSTALLATION				
21-29-1	MS21042L08	Nut	X	8
2	NAS1149FN816P	Washer	X	8
3	D811-1*	Line Assembly	X	1
4	MS21919WDG9	Clamp	X	1
5	C046-18	Frame – Lower (LH, Ref)		
6	MS21919WDG8	Clamp	X	1
7	MS27039C0806	Screw	X	5
8	MS21919WDG10	Clamp	X	4
9	D810-1*	Line Assembly	X	1
10	MS27039C0807	Screw	X	2
11	MS21919WDG6	Clamp	X	4
12	MS27039C0809	Screw	X	1
13	D794-1	Hose Assembly (Ref, see Figure 21-27)		
14	D777-1	Compressor Assembly (Ref, see Figure 21-5)		
15	C233-1	Vertical Firewall (Ref)		
16	MS3367-5-9	Ty-Rap (see Figure 21-27)	X	3
17	D783-1	Condenser (Ref, see Figure 21-13)		
18	D811-2**	Line Assembly	X	1
19	D810-2**	Line Assembly	X	1

NOTES * Ship S/N 10001 thru 29999 with A/C installed.
 ** Ship S/N 30001 and subsequent with A/C installed.

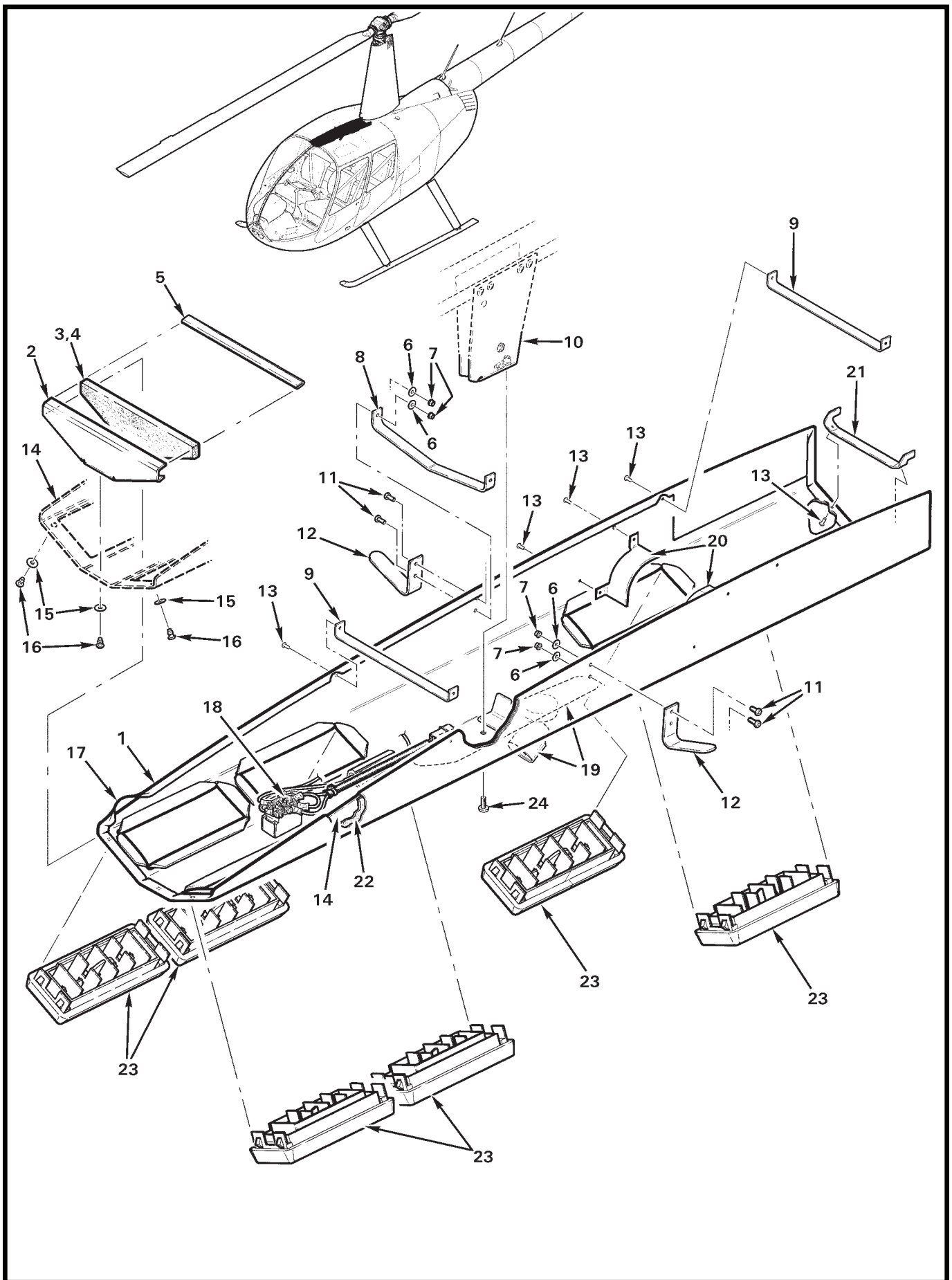

FIGURE AND INDEX NUMBER	PART NUMBER	DESCRIPTION	PARTS AVAIL	QTY PER ASSY
		AIR CONDITIONING - DUCT ASSEMBLY INSTALLATION		
21-31-1	D796-1	Duct Assembly (includes items 2 thru 24)	X	1
2	D797-2	Bracket	X	1
3	D812-4	Insulation*	X	1
4	B270-14	Adhesive	X	A/R
5	A226-15	Trim	X	1
6	NAS1149FN416P	Washer	X	4
7	MS21042L04	Nut	X	4
8	D797-4	Strap	X	1
9	D797-6	Strap	X	2
10	D122-1	Bracket Assembly (Ref, see Figure 63-11)	X	2
11	MS35206-215	Screw	X	4
12	A752-1	Angle	X	2
13	MS20470AD3	Rivet	X	10
14	D797-1	Duct	X	1
15	NAS1149FN616P	Washer	X	3
16	B204-2	Rivet (blind; alternate part no.1693-0414)	X	3
17	B298-31	Headliner* (Dark blue)	X	A/R
	B298-33	Headliner* (Gray)	X	A/R
	B298-34	Headliner* (Tan)	X	A/R
18	D799-4	Switch Assembly - Power (Ref)		
19	D799-8	Light Assembly (Ref)		
20	D797-3	Scoop	X	2
21	D797-5	Bracket	X	1
22	B298-102	Foam* (Black)	X	A/R
23	10.124.63	Louver and Bezel Assembly	X	6
24	MS27039C0807	Screw	X	1

NOTES * Install using item 4.

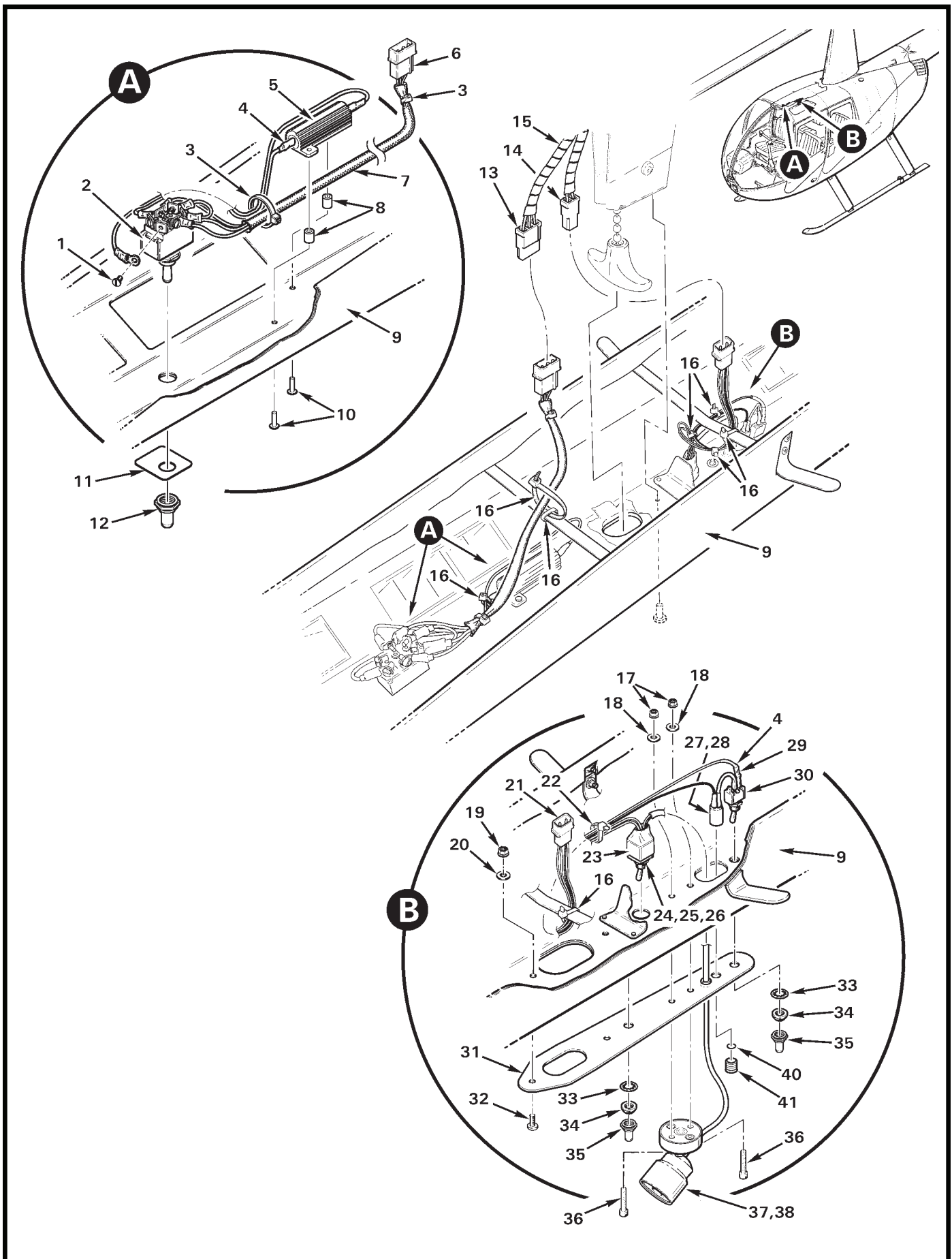

FIGURE AND INDEX NUMBER	PART NUMBER	DESCRIPTION	PARTS AVAIL	QTY PER ASSY
		AIR CONDITIONING - DUCT ASSEMBLY COMPONENTS		
21-33-1	—	Screw	O	6
2	D799-4	Switch Assembly - Power (Incl items 3 thru 7, 12, and 16)	X	1
	MS25201-4	Switch - On/Off (compressor; includes item 1)	X	1
3	MS3367-4-9	Ty-Rap	X	2
4	B158-2	Heat Shrink	X	A/R
5	RH50	Resistor (3Ω, 50w)	X	1
6	B263-14	Housing	X	1
	B263-1	Pin (pins 2 and 3)	X	2
	B263-3	Pin (pin 1)	X	1
7	B266-4	Sleeving (expandable)	X	A/R
8	A130-55	Spacer	X	2
9	D796-1	Duct Assembly (Ref, see also Figure 21-31)		
10	MS20470AD4	Rivet	X	2
11	D122-4	Plate	X	1
12	C1131/28	Boot	X	1
13	B263-15	Housing	X	1
	B263-2	Socket	X	3
14	B263-13	Housing	X	1
	B263-2	Socket	X	2
15	B161-4	Spirap	X	A/R
16	MS3367-4-9	Ty-Rap	X	A/R
17	MS21042L06	Nut	X	2
18	NAS1149FN616P	Washer	X	2
19	MS21042L08	Nut	X	1
20	NAS1149FN816P	Washer	X	1
21	B263-12	Housing	X	1
	B263-1	Pin	X	2
22	MS3367-4-9	Ty-Rap	X	1
23	B158-12	Heat Shrink	X	A/R
24	B300-5	Switch (Incl items 33 and 34)	X	1
	B158-2	Heat Shrink (around leads)	X	A/R

NOTES

Continues

FIGURE AND INDEX NUMBER	PART NUMBER	DESCRIPTION	PARTS AVAIL	QTY PER ASSY
AIR CONDITIONING - DUCT ASSEMBLY COMPONENTS (Cont'd)				
21-33-25	B0207C1K650F5T	Resistor (not shown)	X	1
26	B0207C3K400F5T	Resistor (not shown)	X	1
27	CNX310-000-X-4-1-12	Connector	X	1
28	E1003	LED (not shown)	X	1
29	B0207C1K210F5T	Resistor	X	1
30	B300-1	Switch (Incl items 33 and 34)	X	1
	B158-2	Heat Shrink (around leads)	X	A/R
31	D122-6	Plate	X	1
32	MS27039C0807	Screw	X	1
33	B227-3	Lockwasher	X	2
34	B227-4	Dress Nut	X	2
35	N-5030S	Boot	X	2
36	NAS1352-06-8	Screw	X	2
37	D799-8	Light Assembly (Incl items 21, 23 thru 31, 35, and 38 thru 41) .	X	1
38	D606-1	Spotlight	X	1
39	NAS557-3A*	Grommet	X	1
40	A215-008*	O-Ring	X	1
41	CMC321-CTP	Lens	X	1

NOTES * Not shown; installed on earlier R44s.

Intentionally Blank

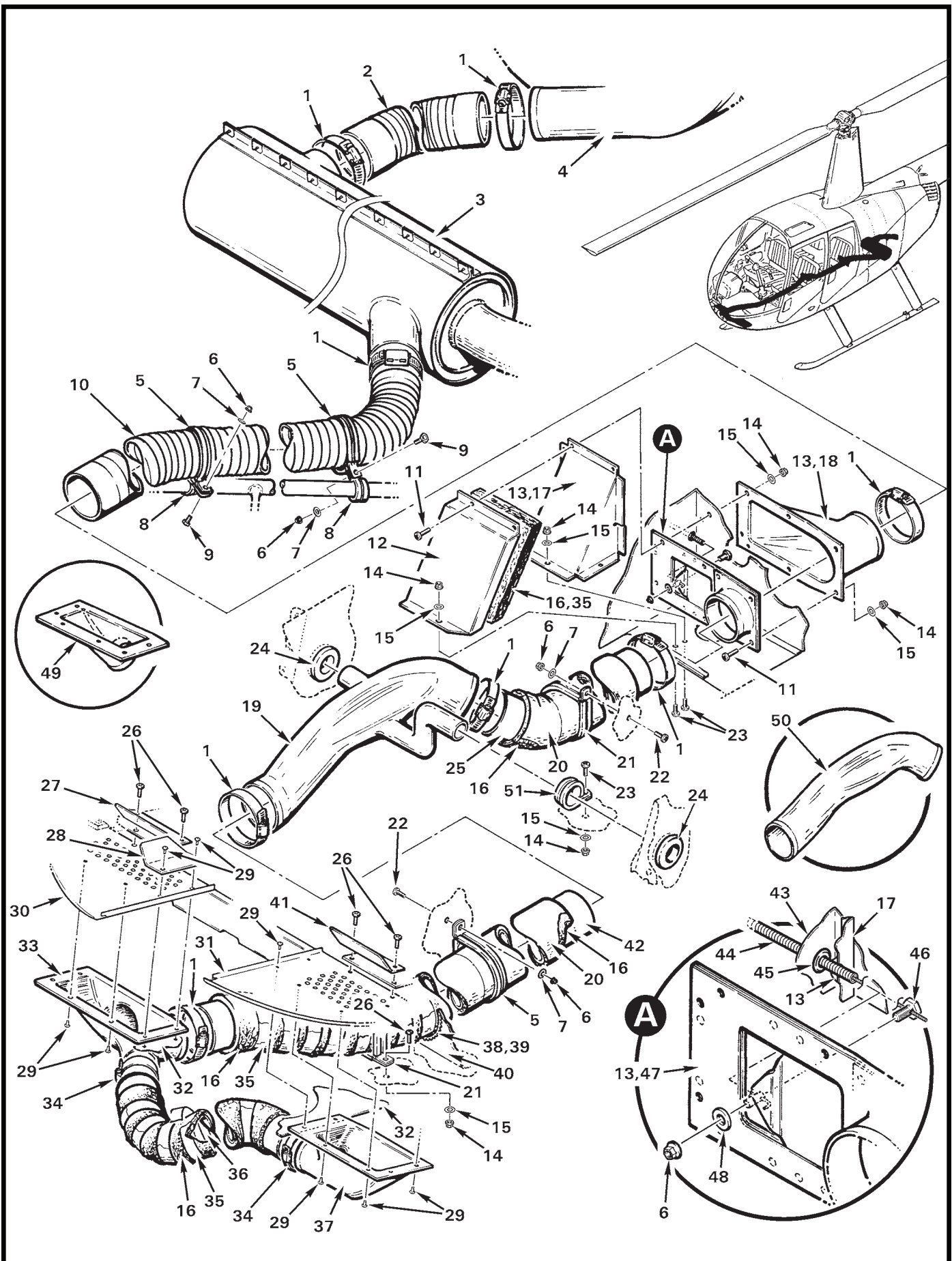

FIGURE AND INDEX NUMBER	PART NUMBER	DESCRIPTION	PARTS AVAIL	QTY PER ASSY
CABIN HEATER - SYSTEM INSTALLATION				
21-37-1	B277-36	Clamp	X	A/R
2	A785-12	Hose	X	1
3	C169-2	Shroud Assembly - Muffler (Ref, see also Figure 71-21)		
4	C236	Scroll Assembly - Lower (Ref)		
5	MS21919WDG42	Clamp ([1] required to install item 10 on IO-540 ships)	X	2
6	MS21042L3	Nut	X	A/R
7	NAS1149F0332P	Washer	X	A/R
8	MS21919WDG16	Clamp ([1] required to install item 10 on IO-540 ships)	X	2
9	NAS6603-3	Bolt	X	1
10	A785-13	Hose	X	1
11	MS27039C0808	Screw	X	8
12	C753-1	Cover (seal around using item 13)	X	1
13	B270-1	Sealant (2-oz tube)	X	A/R
14	MS21042L08	Nut	X	A/R
15	NAS1149FN816P	Washer	X	A/R
16	R5111	Insulation (Microlite AA, 1" thick)	X	A/R
17	C625-1	Box (seal around using item 13)	X	1
18	A623-1	Inlet (seal around using item 13)	X	1
19	D164-2	Duct - Aft Outlet (ship S/N 0151 and higher)	X	1
20	A701-2	Foil Tape (6-inch width; aft of item 40)	X	A/R
21	MS21919WDG48	Clamp	X	A/R
22	MS27039C1-07	Screw	X	2
23	MS27039C0806	Screw	X	1
24	MS35489-23	Grommet	X	2
25	A785-14	Hose	X	1
26	MS27039C0807	Screw	X	A/R
27	B189-2	Deflector	X	1
28	B189-1	Deflector (side)	X	1
29	MS20470AD3	Rivet	X	A/R
30	C232-4	Panel - Floor, (RH, Ref)		
31	C232-3	Panel - Floor, (LH, Ref)		

NOTES

Continues

FIGURE AND INDEX NUMBER	PART NUMBER	DESCRIPTION	PARTS AVAIL	QTY PER ASSY
CABIN HEATER - SYSTEM INSTALLATION (Cont'd)				
21-37-32	C408-1	Panel - Floor, Center (Ref)		
33	D165-1 *	Outlet - (RH, Ref)		
34	B277-24	Clamp	X	2
35	A701-1	Tape - Aluminum (1 in. width; forward of item 40)	X	1
36	A785-24	Hose	X	1
37	D166-1 *	Outlet - (LH, Ref)		
38	MS21266-1N	Grommet (install using item 39)	X	A/R
39	B270-14.5oz	Adhesive (0.5-oz bottle, or B270-8qt)	X	A/R
40	D230	Bulkhead (Ref)		
41	B189-4	Deflector	X	1
42	A785-23	Hose (ship S/N 0271 thru 0357)	X	1
43	C292	Keel Panel (Ref)		
44	A522-8	Control (Ref, see Figure 21-1)		
45	MS35489-4	Grommet	X	1
46	A462-1	Fitting	X	1
47	B019-3	Valve Assembly (seal around using item 13)		
48	NAS1149F0363P	Washer	X	1
49	B164-1 *	Outlet-RH (Ref, no longer available. Used on single-forward-outlet heater installation ship S/N 0001 thru 0270.)		
50	D164-1 *	Duct (Ref, no longer available; ship S/N 0001 thru 0150.)		
51	MS21919WDG18	Clamp	X	1

NOTES * No longer available. Contact RHC Customer Service for replacement.

Intentionally Blank

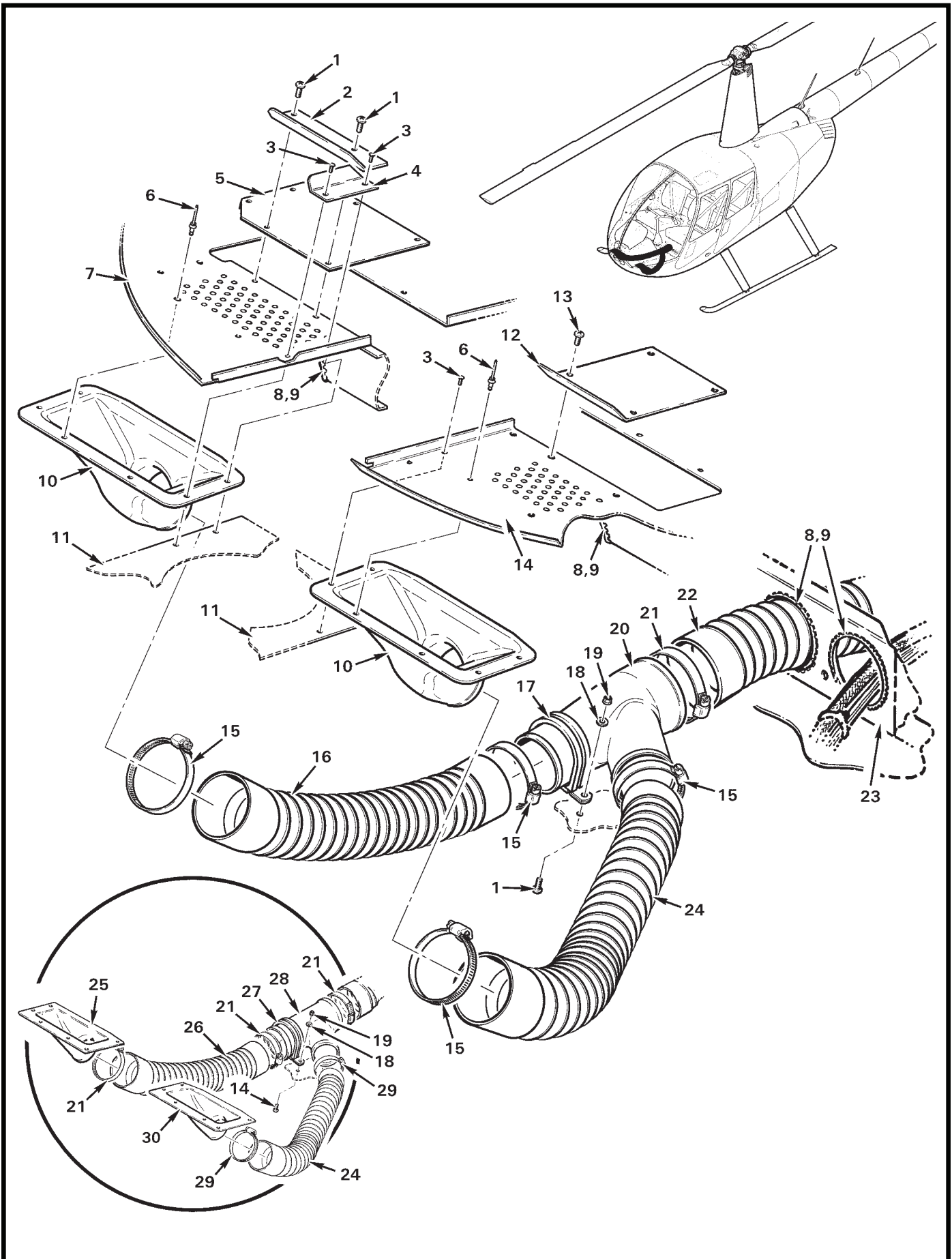

FIGURE AND INDEX NUMBER	PART NUMBER	DESCRIPTION	PARTS AVAIL	QTY PER ASSY
CABIN HEATER - SPLITTER INSTALLATION				
21-41-1	MS27039C0807	Screw	X	3
2	B189-2	Deflector	X	1
3	MS20470AD3	Rivet	X	4
4	B189-1	Deflector (side)	X	1
5	A412-2	Cover	X	1
6	NAS1919B04S01 *	Rivet	X	8
7	C232-4	Panel - Floor, RH (Ref)		
8	MS21266-1N	Grommet (install using item 9)	X	A/R
9	B270-14.5oz	Adhesive (0.5-oz bottle or B270-8qt)	X	A/R
10	B164-3	Outlet	X	1
11	C408-1	Panel - Floor, Center (Ref)		
12	B189-4	Deflector	X	1
13	MS27039C0806	Screw	X	8
14	C232-3	Panel - Floor (LH, Ref)		
15	B277-28	Clamp	X	4
16	A785-34	Hose	X	1
17	MS21919WDG32	Clamp	X	1
18	NAS1149FN816P	Washer	X	1
19	MS21042L08	Nut	X	1
20	B391-2	Splitter	X	1
21	B277-36	Clamp ([3] required when item 28 "15" installed)	X	1
22	A785-29	Hose	X	1
23	D230-1	Bulkhead (Ref)		
24	A785-25	Hose	X	1
25	B164-1	Outlet (RH, Ref. No longer available. To replace, order items 10, 15, 16, and 20.)		
26	A785-27	Hose	X	1
27	MS21919WDG40	Clamp	X	1
28	B391-1	Splitter (Ref, no longer available. Order items 10, 15, 16, and 20).		
29	B277-24	Clamp	X	2
30	B164-2	Outlet (LH, Ref. No longer available. Order item 10.)		

NOTES

Intentionally Blank

CHAPTER 22

AUTOPILOT

<i>Figure</i>	<i>Title</i>	<i>Page</i>
22-1	(Pitch) Servo Assembly Installation and Components	22.0
22-5	(Roll) Servo Assembly Installation	22.4
22-7	Flight Control Computer Installation	22.6

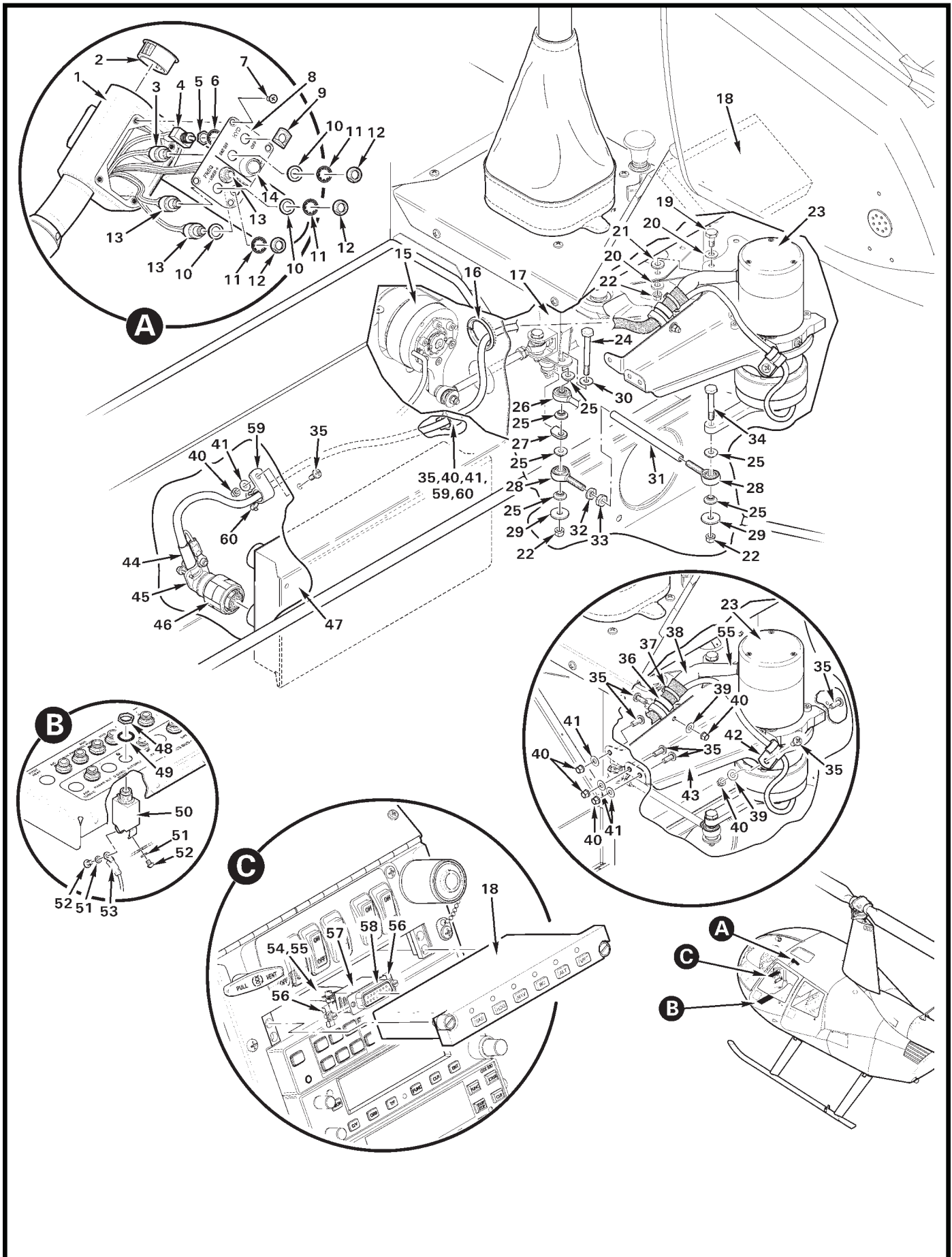

FIGURE AND INDEX NUMBER	PART NUMBER	DESCRIPTION	PARTS AVAIL	QTY PER ASSY
		(PITCH) SERVO ASSEMBLY INSTALLATION AND COMPONENTS		
22-1-1	C058-15*	Grip Assembly (Incl items 2 thru 14, and 17)	X	1
	C058-14**	Grip Assembly (Incl items 2 thru 14, and 17)	X	1
2	2703	Hole Plug (install using B270-15 adhesive)	X	1
3	B227-7	Switch Assembly – “AP OFF” (Incl items 10 thru 12)	X	1
4	B300-3	Switch Assembly – “HYD OFF” (Incl items 5 and 6)	X	1
5	—	Nut	X	1
6	—	Lockwasher	X	1
7	MS24693-S1	Screw	X	4
8	C214-27	Plate	X	1
9	D443-7	Guard	X	1
10	94773A770***	Washer	X	1
11	B227-3	Lockwasher	X	1
12	B227-4	Dress Nut	X	1
13	B227-2	Switch Assembly (Incl items 10 thru 12)	X	3
14	B227-8	Switch – Trim (Includes 801801000 cap, 702501201 dress nut, and items 10 and 11.)	X	1
	801801000***	Cap	X	1
	702501201***	Dress Nut	X	1
15	D354-1	Servo Assembly (Roll, Ref; see Figure 22-5)		
16	NAS557-16A	Grommet	X	1
17	D320-1	Cyclic Stick Assembly (Ref)		
18	O1309-01-01	Control Panel	X	1
19	NAS6603-3	Bolt	X	2
20	NAS1149F0332P	Washer	X	4
21	NAS1149F0363P	Washer	X	2
22	D210-3	Nut	X	2
23	D354-2	Servo Assembly (Pitch; includes items 35 thru 40, 42 thru 46, and 55.)	X	1
24	NAS6603-22	Bolt	X	1
25	A341-1	Spacer	X	4
26	B564-1	Link (Ref, see Figure 67-17)		
27	D353-2	Link	X	1
28	A127-3	Rod End	X	2
29	A141-17	Washer	X	2
30	NAS620-10L	Washer	X	1

NOTES * Ship S/N 10001 and subsequent.
 ** Ship S/N 0001 thru 9999.
 *** C&K Components part no.

Continues

FIGURE AND INDEX NUMBER	PART NUMBER	DESCRIPTION	PARTS AVAIL	QTY PER ASSY
(PITCH) SERVO ASSEMBLY INSTALLATION AND COMPONENTS (Cont'd)				
22-1-31	A336-7	Tube	X	1
32	B330-7	Palnut	X	2
33	AN315-3R	Nut	X	2
34	NAS6603-14	Bolt	X	1
35	MS27039C0806	Screw	X	3
36	MS21919WDG6	Clamp	X	1
37	MS3367-4-9	Ty-Rap	X	A/R
	MS3367-5-9	Ty-Rap	X	A/R
38	B266-8	Sleeving	X	A/R
39	NAS1149FN816P	Washer	X	2
40	MS21042L08	Nut	X	3
41	NAS1149FN832P	Washer	X	3
42	MS21919WDG3	Clamp	X	1
43	D353-3	Brace	X	1
44	B158-8	Heat Shrink	X	A/R
45	M85049/39-13W	Strain Relief	X	1
46	D38999/26FC35SA	Plug	X	1
	B267-3	Terminator (not shown)	X	1
	B267-4	Terminator (not shown)	X	1
47	01311-03-01	Computer (Ref)		
48	—	Nut	O	1
49	—	Lockwasher	O	1
50	B297-5	Circuit Breaker (5 amp; includes items 48, 49, 51, and 52) . . .	X	1
51	—	Washer	O	1
52	—	Screw	O	1
53	-2103	Wire (Ref)		
54	D323-2	Harness Assembly (Incl items 55 thru 58)	X	1
55	B158-6	Heat Shrink	X	A/R
56	B269-31	Screw Lock (male)	X	2
57	B269-22	Backshell	X	1
58	B269-8	Receptacle	X	1
59	M23190/1-2	Clamp	X	1
60	MS3367-5-9	Ty-Rap	X	A/R

NOTES

Intentionally Blank

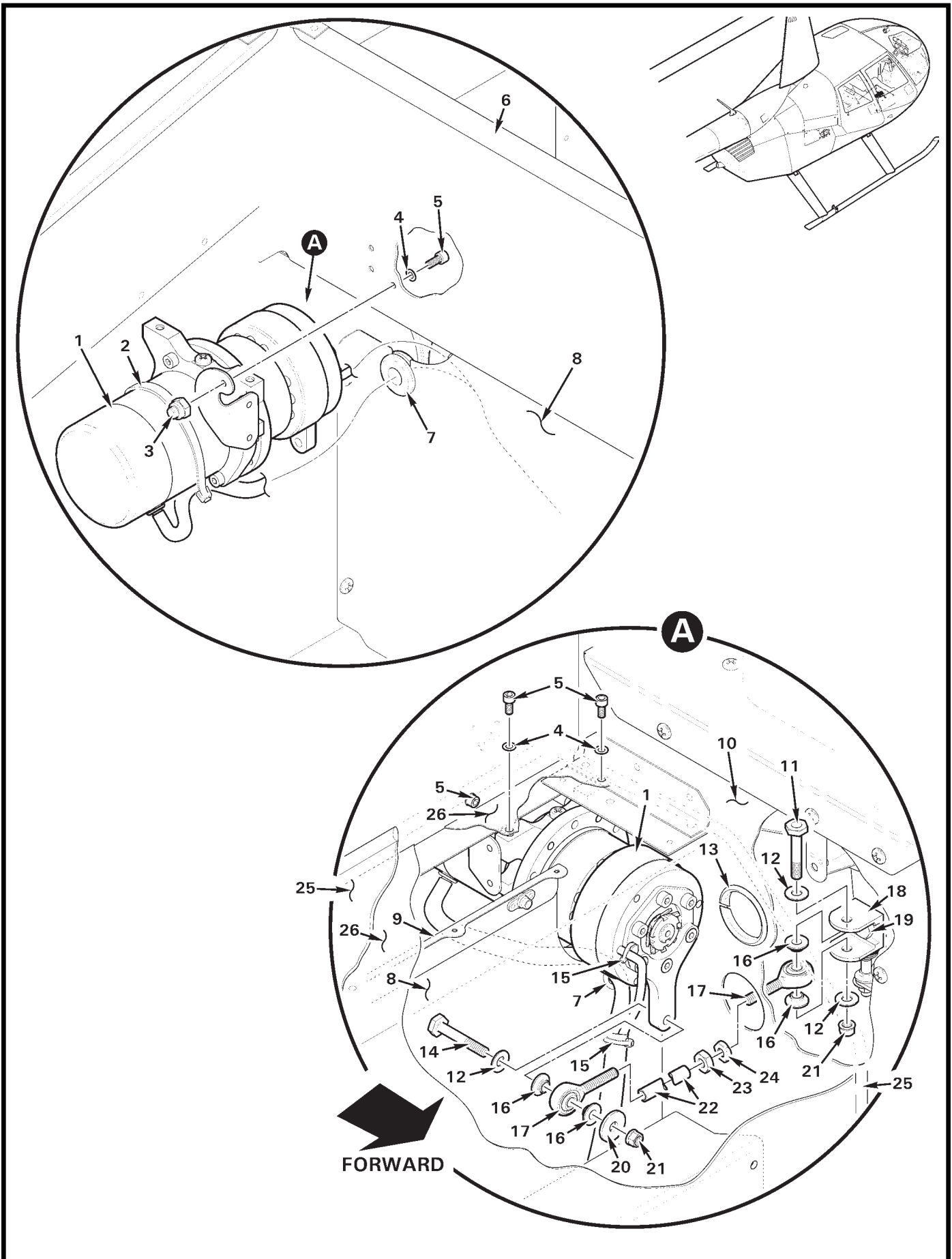

FIGURE AND INDEX NUMBER	PART NUMBER	DESCRIPTION	PARTS AVAIL	QTY PER ASSY
(ROLL) SERVO ASSEMBLY INSTALLATION				
22-5-1	D354-1	Servo Assembly – Roll (Incl items 2 and 15)	X	1
2	MS3367-7-9	Ty-Rap	X	1
3	B340-4	Nut	X	3
4	NAS620-8L	Washer	X	3
5	NAS1352-08-6P	Screw	X	3
6	C290-1	Seat Support Assembly – RH FWD (Ref)		
7	MS35489-11	Grommet	X	1
8	C748-6	Cover Assembly (Ref)		
9	D357-1	Angle Assembly (Ref)		
10	C293-4	Forward Keel Panel – RH (Ref)		
11	NAS6603-12	Bolt	X	1
12	NAS1149F0332P	Washer	X	3
13	NAS557-16A	Grommet (Ref)		
14	NAS6603-14	Bolt	X	1
15	MS3367-4-9	Ty-Rap	X	A/R
16	A341-1	Spacer	X	4
17	A127-3	Rod End	X	2
18	D352-6	Clevis	X	1
19	NAS6604-10	Bolt (Ref; existing hardware, see Figure 67-29)		
20	A141-17	Washer	X	1
21	D210-3	Nut	X	2
22	A336-8	Tube	X	1
23	AN315-3R	Nut	X	1
24	B330-7	Palnut	X	1
25	C469-4	Carpet (Ref)		
26	C391-6	Cover (Ref)		

NOTES

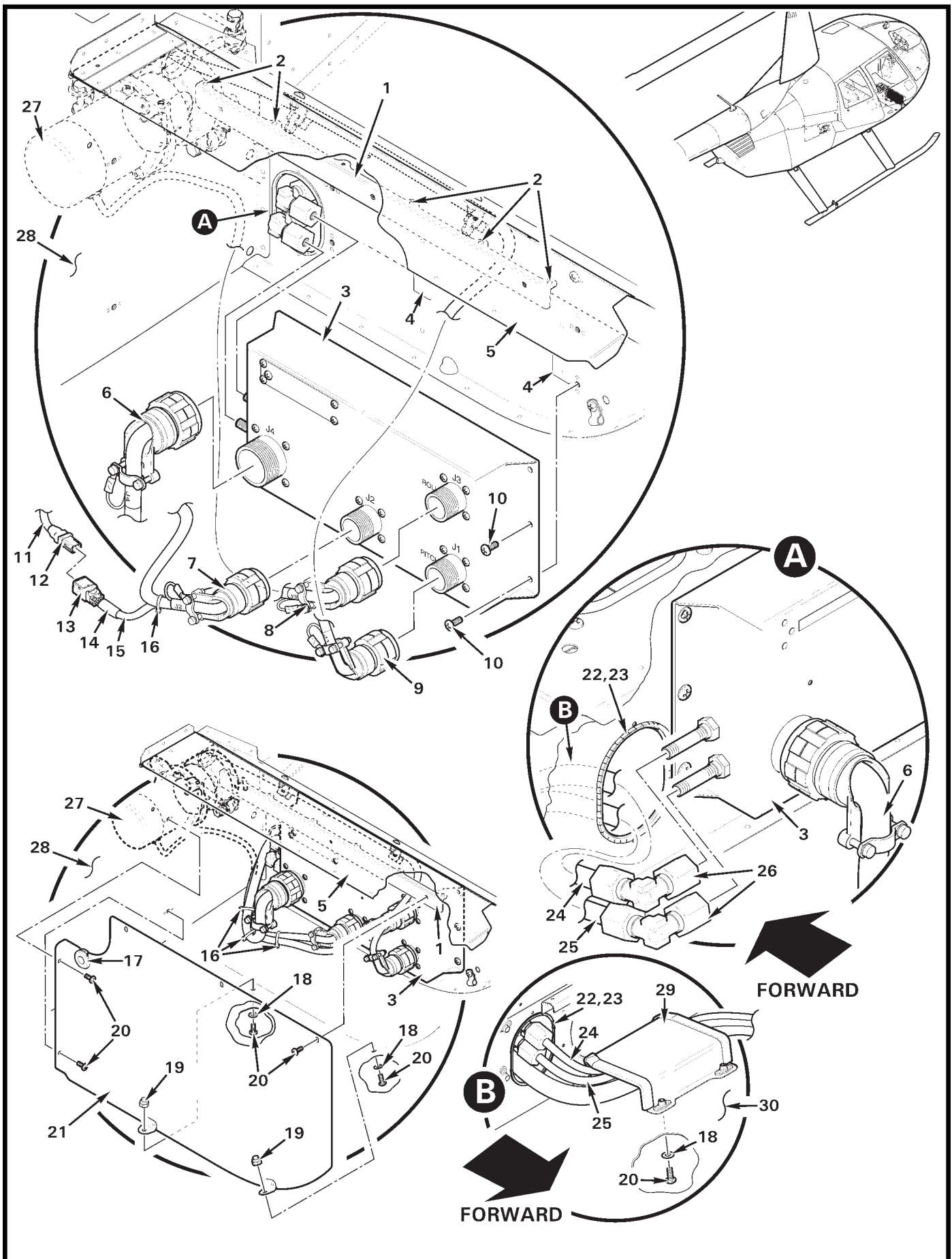

FIGURE AND INDEX NUMBER	PART NUMBER	DESCRIPTION	PARTS AVAIL	QTY PER ASSY
FLIGHT CONTROL COMPUTER INSTALLATION				
22-7-1	D357-1	Angle Assembly	X	1
2	MS20470AD3	Rivet	X	6
3	01311-03-01	Computer	X	1
4	A701-3	Tape	X	A/R
5	C391-6	Cover (Ref)		
6	D323-12	Harness Assembly – G500H	X	1
	D323-13	Harness Assembly – Aspen	X	1
7	D323-2	Harness Assembly – Autopilot (Std; Incl items 13 thru 15)	X	1
	D323-14	Harness Assembly – Autopilot (Long; Incl items 13 thru 15) . . .	X	1
8	D354-1	Servo Wire Harness Assembly (Roll)	X	1
9	D354-2	Servo Wire Harness Assembly (Pitch)	X	1
10	MS27039C0806	Screw	X	4
11	D323-10	Harness Assembly – EFIS G500H (Incl items 12, 14, 15, B268-3 Lacing Tape, and wires)	X	1
	D323-11	Harness Assembly – EFIS Aspen (Incl items 12, 14, 15, B268-3 Lacing Tape, and wires)	X	1
12	D269-12	Receptacle (9-pin)	X	1
13	D269-11	Plug (9-socket)	X	1
14	B158-6	Heat Shrink	X	A/R
15	B266-4	Sleeving	X	A/R
16	MS3367-5-0	Ty-Rap	X	A/R
17	MS35489-11	Grommet	X	1
18	B527-08	Washer	X	6
19	B340-4	Nut	X	2
20	B526-6	Screw	X	8
21	C748-6	Cover Assembly (Incl A748-3 Angle [2] and MS20470AD3 Rivet [4])	X	1
22	MS21266-1N	Grommet (install using item 23)	X	A/R
23	B270-8qt	Adhesive	X	A/R
24	A729-23	Static Tube (Ref)		
25	A729-23	Pitot Tube (Ref)		
26	50-4-N-0	Elbow	X	2
27	D354-1	Servo Assembly – Roll (Ref)		
28	C293-4	Keel Panel – RH (Ref)		
29	D555-4	Shield Assembly	X	8
30	C272-1	Chin (Ref)		

NOTES

Intentionally Blank

CHAPTER 25

FURNISHINGS

<i>Figure</i>	<i>Title</i>	<i>Page</i>
25-1	Seat Installation	25.0
25-5	Aft Seat Support Installation	25.4
25-9	Heated Seats – Backrest Installation	25.8
25-11	Heated Seats – Seat Cushion Installation	25.10
25-13	Heated Seats – Wiring Installation	25.12
25-17	Seat Belt Installation	25.16
25-19	Seat Belt Installation	25.18
25-21	Five-Point Harness Installation	25.20
25-23	Five-Point Harness Installation	25.22
25-25	Four-Point Harness Installation	25.24
25-27	Four-Point Harness Installation	25.26
25-29	Carpet Installation	25.28
25-33	Headliner and Insulation Installation	25.32
25-37	Fire Extinguisher Installation	25.36
25-39	Fire Extinguisher Installation	25.38
25-41	Fire Extinguisher Installation	25.40
25-41B	Kannad ELT Installation	25.41A
25-45	Pointer ELT and Antenna Installation	25.44
25-49	Guard Assembly Installation	25.48

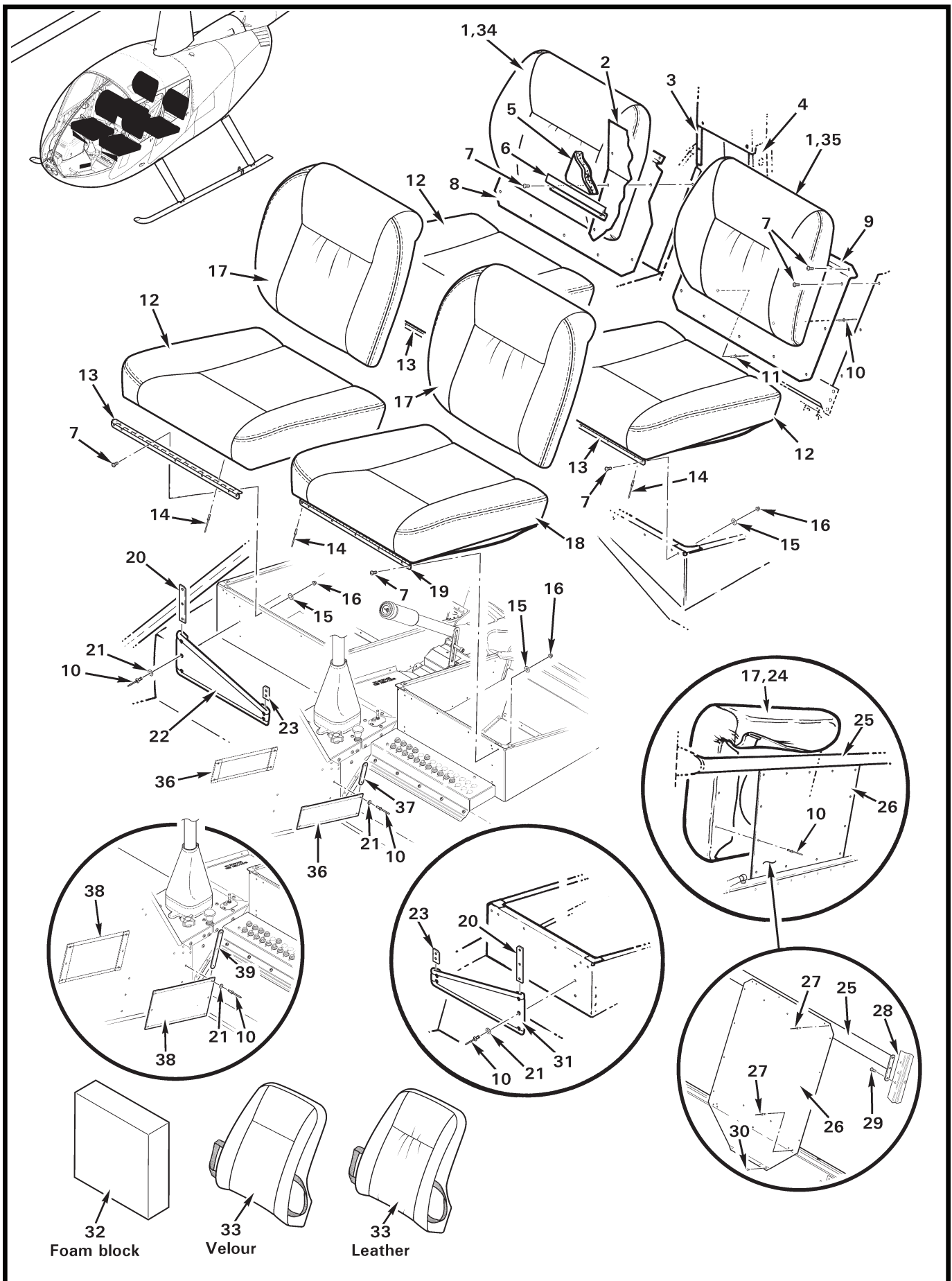

FIGURE AND INDEX NUMBER	PART NUMBER	DESCRIPTION	PARTS AVAIL	QTY PER ASSY
SEAT INSTALLATION				
25-1-1	F936-2*	Backrest Assembly – Aft (RH and LH)	X	2
2	C474-1	Cover (Ref)		
3	C351-2	Brace – Aft Seat Back (RH)	X	1
4	C351-1	Brace – Aft Seat Back (LH)	X	1
5	C003-2	Insulation (Ref; see Figure 25-33)		
6	C474-3	Trim (Ref; see Figure 6-11)	X	1
7	MS27039C0806	Screw	X	54
8	C465-2	Panel (RH)	X	1
9	C465-1	Panel (LH)	X	1
10	B204-2	Rivet (blind)	X	51
11	B204-3	Rivet (blind, lower aft backrests only)	X	4
12	C928-9*	Seat Assembly (Incl items 13 and 14)	X	3
13	C928-5	Hinge	X	1
14	B204-4	Rivet (blind, countersunk)	X	39
15	NAS1149FN816P	Washer	X	27
16	MS21042L08	Nut	X	27
17	F936-1*	Backrest Assembly – Fwd (RH and LH, install using items 10 and 24)	X	2
18	C930-9*	Seat Assembly – Fwd (LH, includes items 14 and 19)	X	1
19	C930-6	Hinge	X	1
20	A913-1	Strip (earlier R44s, this location)	X	1
21	NAS1149FN632P	Washer	X	13
22	A912-1	Pocket	X	1
23	A913-2	Strip (earlier R44s, this location)	X	1
24	B270-18	Adhesive	X	A/R
25	C423-1	Tube Assembly – Forward Seat Backs	X	1
26	C925-1**	Panel – Forward Back Rest (LH and RH)	X	2
27	NAS9301B-4-02	Rivet	X	11
28	C403-11	Post Assembly (LH, Ref)		
29	MS27039C0807	Screw	X	6
30	MS20470AD3	Rivet	X	8
31	A912-4	Pocket (LH, earlier R44s)	X	1
32	A693-1	Cushion (for shorter pilots, 14 in. X 14 in. X 3 in. foam block)	X	1
33	A693-2*	Cushion Assembly (optional; for shorter pilots)	X	1
34	C003-10*	Seat Back Assembly – RH (Incl items 1, 8, and 10)	X	1

NOTES * Refer to *chart* at the end of parts list when ordering. Include code after dash no., for example, F936-2 in gray velour, order "F936-2GRV".
 ** C933 is superseded by C925-1.

Continues

FIGURE AND INDEX NUMBER	PART NUMBER	DESCRIPTION	PARTS AVAIL	QTY PER ASSY														
SEAT INSTALLATION (Cont'd)																		
25-1-35	C003-11*	Seat Back Assembly – LH (Incl items 1, 9, and 10)	X	1														
36	A912-6	Pocket Assembly (RH and LH)	X	2														
37	A913-5	Strip (earlier R44s, this location)	X	A/R														
38	A912-5*	Pocket Assembly (RH and LH, earlier R44s)	X	1														
39	A913-3	Strip (earlier R44s)	X	2														
<table border="1" data-bbox="784 625 1118 926"> <thead> <tr> <th>Code</th> <th>Definition</th> </tr> </thead> <tbody> <tr> <td>GRL</td> <td>Gray leather</td> </tr> <tr> <td>GRV</td> <td>Gray velour</td> </tr> <tr> <td>TNL</td> <td>Tan leather</td> </tr> <tr> <td>TNV</td> <td>Tan velour</td> </tr> <tr> <td>CHL</td> <td>Charcoal leather</td> </tr> <tr> <td>CHV</td> <td>Charcoal velour</td> </tr> </tbody> </table>					Code	Definition	GRL	Gray leather	GRV	Gray velour	TNL	Tan leather	TNV	Tan velour	CHL	Charcoal leather	CHV	Charcoal velour
Code	Definition																	
GRL	Gray leather																	
GRV	Gray velour																	
TNL	Tan leather																	
TNV	Tan velour																	
CHL	Charcoal leather																	
CHV	Charcoal velour																	

NOTES * Refer to *chart* at the end of parts list when ordering. Include code after dash no., for example, C003-11 in tan leather, order "C003-11TNL".

Intentionally Blank

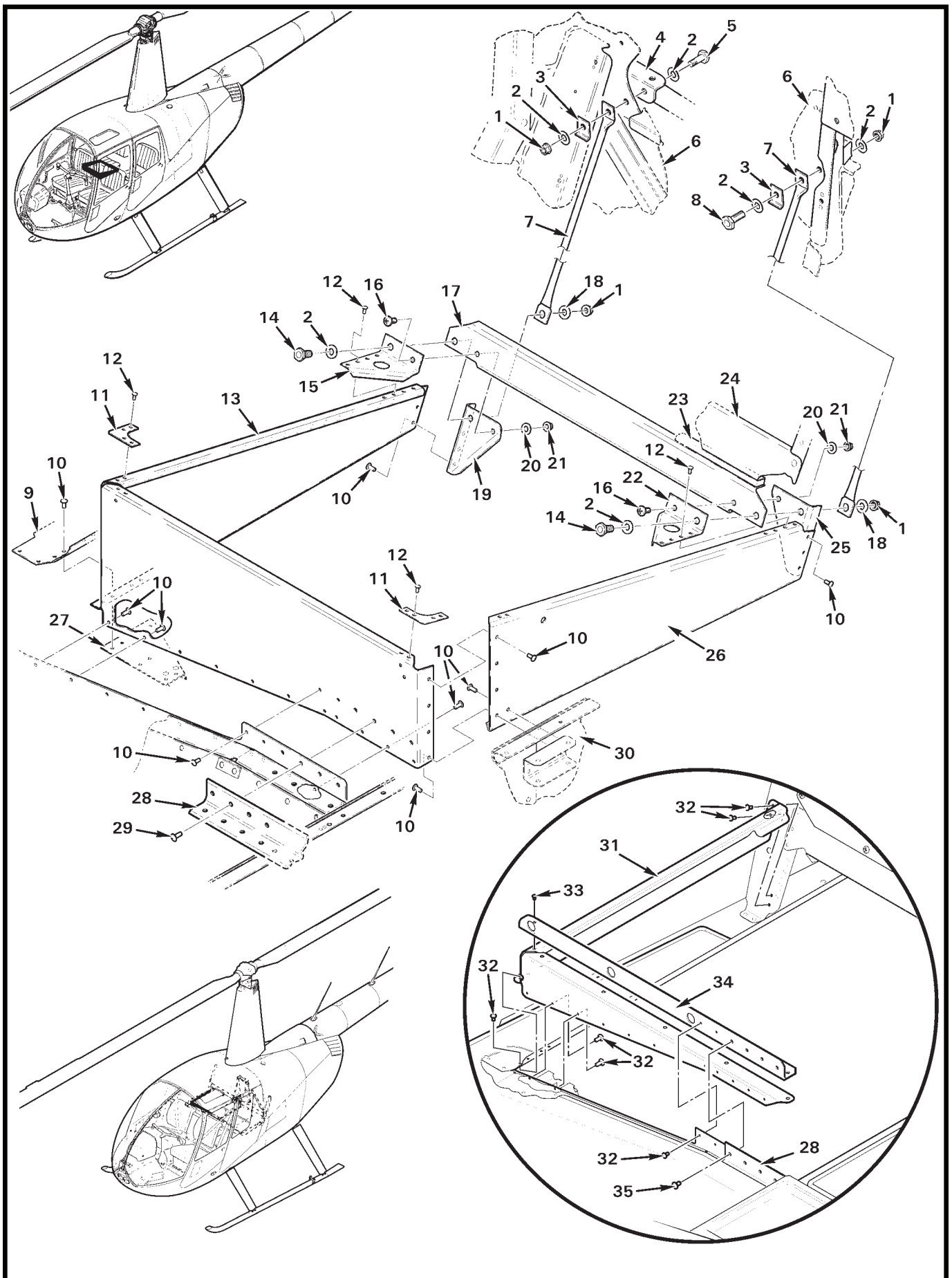

FIGURE AND INDEX NUMBER	PART NUMBER	DESCRIPTION	PARTS AVAIL	QTY PER ASSY
AFT SEAT SUPPORT INSTALLATION				
25-5-1	D210-4	Nut	X	8
2	NAS1149F0432P	Washer	X	12
3	C632-1	Angle	X	4
4	C046-2	Lower Frame (Ref)		
5	NAS6604-4	Bolt (upper outboard location)	X	2
6	C015	Cabin Assembly (Ref)		
7	C381-1	Strap	X	4
8	NAS6604-3	Bolt	X	2
9	C287-2	Panel (RH)	X	1
	C287-1	Panel (LH, not shown)	X	1
10	MS20470AD4	Rivet	X	55
11	A291-7	Gusset	X	4
12	NAS1097AD3	Rivet	X	32
13	C291-4	Support (RH)	X	1
	C291-3	Support (LH, not shown)	X	1
14	NAS6604-2	Bolt	X	4
15	C248-2	Gusset	X	2
16	MS27039C1-06	Screw	X	4
17	C249-1	Beam	X	2
18	NAS1149F0463P	Washer	X	4
19	C248-4	Bracket (RH)	X	2
20	NAS1149F0332P	Washer	X	4
21	D210-3	Nut	X	4
22	C248-1	Gusset	X	2
23	A260-5	Tape – Foam	X	A/R
24	C288-1	Beam (Ref)		
25	C248-3	Bracket (LH)	X	2
26	C291-6	Support (RH)	X	1
	C291-5	Support (LH, not shown)	X	1
27	C382-1	Panel	X	1
28	C374-1	Angle (Ref)		
29	MS20470AD5	Rivet (Ref; [4] at this location)	X	14
30	C292-2	Keel Panel (Ref)		
31	C704-2*	Support – RH	X	1
	C704-1*	Support (LH, not shown)	X	1

NOTES * Ship S/N 30001 and subsequent.

Continues

FIGURE AND INDEX NUMBER	PART NUMBER	DESCRIPTION	PARTS AVAIL	QTY PER ASSY
AFT SEAT SUPPORT INSTALLATION (Cont'd)				
25-5-32	MS20470AD4*	Rivet	X	38
33	MS20470AD3*	Rivet	X	2
34	C704-12*	Angle – RH	X	1
	C704-11*	Angle (LH, not shown)	X	1
35	MS20470AD5*	Rivet	X	8

NOTES * Ship S/N 30001 and subsequent.

Intentionally Blank

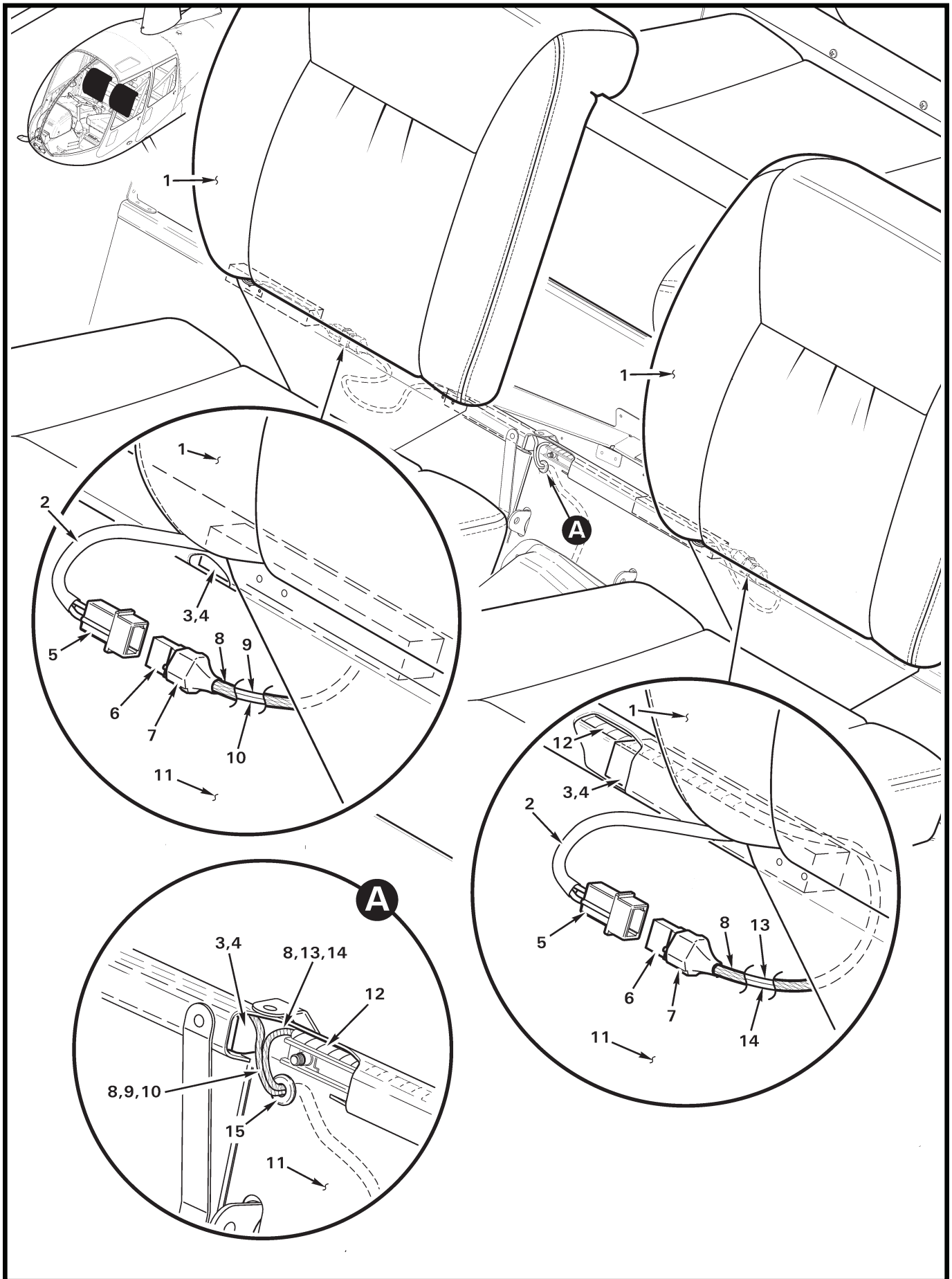

FIGURE AND INDEX NUMBER	PART NUMBER	DESCRIPTION	PARTS AVAIL	QTY PER ASSY
HEATED SEATS – BACKREST INSTALLATION				
25-9-1	F936-5	Back Rest Assembly (RH and LH; includes items 2 thru 5) . . .	X	2
2	B158-3	Heat Shrink	X	A/R
3	F941-5 *	Foam (install using item 4)	X	3
4	B270-8QT	Adhesive	X	A/R
5	B263-32	Housing	X	1
	B263-1	Pin	X	2
	B158-3	Heat Shrink	X	A/R
6	B263-33	Housing	X	1
	B263-2	Socket	X	2
	B268-3	Lacing Tape	X	A/R
7	B158-6	Heat Shrink (around item 6)	X	A/R
8	B266-4	Sleeving	X	A/R
9	C938-2864	Wire (Ref)		
10	C938-2865	Wire (Ref)		
11	C370-1	Panel (Ref)		
12	B161-4	Spirap	X	A/R
13	C938-2868	Wire (Ref)		
14	C938-2869	Wire (Ref)		
15	MS35489-4	Grommet	X	1

NOTES

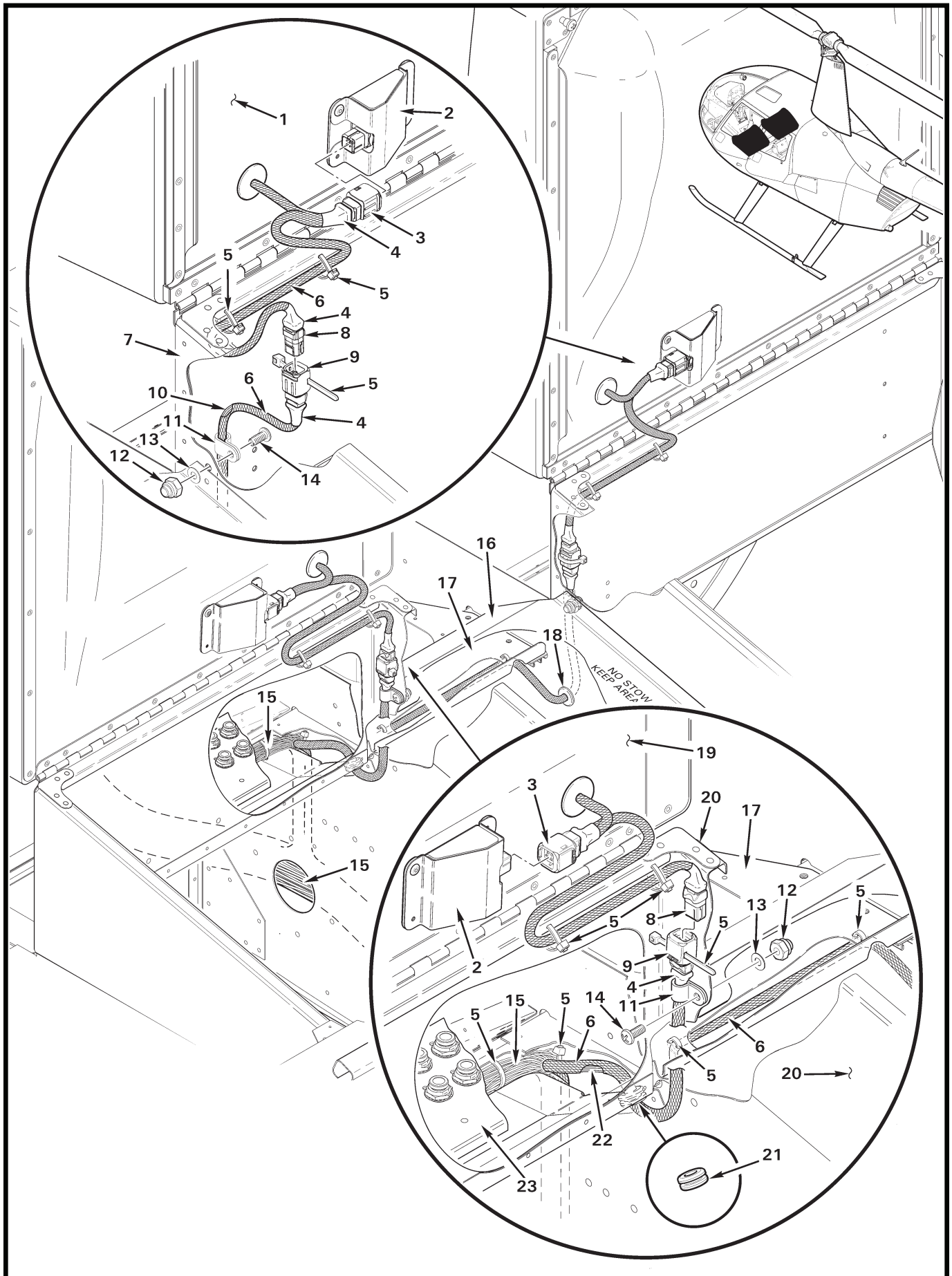

FIGURE AND INDEX NUMBER	PART NUMBER	DESCRIPTION	PARTS AVAIL	QTY PER ASSY
HEATED SEATS – SEAT CUSHION INSTALLATION				
25-11-1	C928-11	Seat Assembly (RH, forward; includes items 2, 4, 6, and 8) . .	X	1
	2 F941-1	Module Assembly (Ref)		
	3 D269-11	Plug	X	1
	4 B158-6	Heat Shrink	X	A/R
	5 MS3367-4-0	Ty-Rap	X	A/R
	6 B266-4	Sleeving	X	A/R
	7 C290-4	Support Assembly – Seat (Ref, RH)		
	8 D269-8	Receptacle	X	1
	9 D269-7	Plug	X	1
10	C938-2417	Wire (Ref)		
	C938-2418	Wire (Ref)		
	C938-2864	Wire (Ref)		
	C938-2886	Wire (Ref)		
	C938-2887	Wire (Ref)		
11	N-4-BK	Clamp	X	2
12	B340-4	Nut	X	2
13	NAS1149FN816P	Washer	X	2
14	MS27039C0806	Screw	X	2
15	C859	Harness Assembly – Cabin (Ref)		
16	C445-1	Cover Assembly (Ref)		
17	D338-3	Plate (Ref)		
18	MS35489-6	Grommet	X	1
19	C930-11	Seat Assembly (LH, forward; includes items 2, 4, 6, and 8) . .	X	1
20	C297-5	Support Assembly – Seat (Ref, LH)		
21	G1042	Grommet	X	1
22	C938-2420	Wire (Ref)		
	C938-2421	Wire (Ref)		
	C938-2868	Wire (Ref)		
	C938-2870	Wire (Ref)		
	C938-2871	Wire (Ref)		
23	C490	Circuit Breaker Panel (Ref)		

NOTES

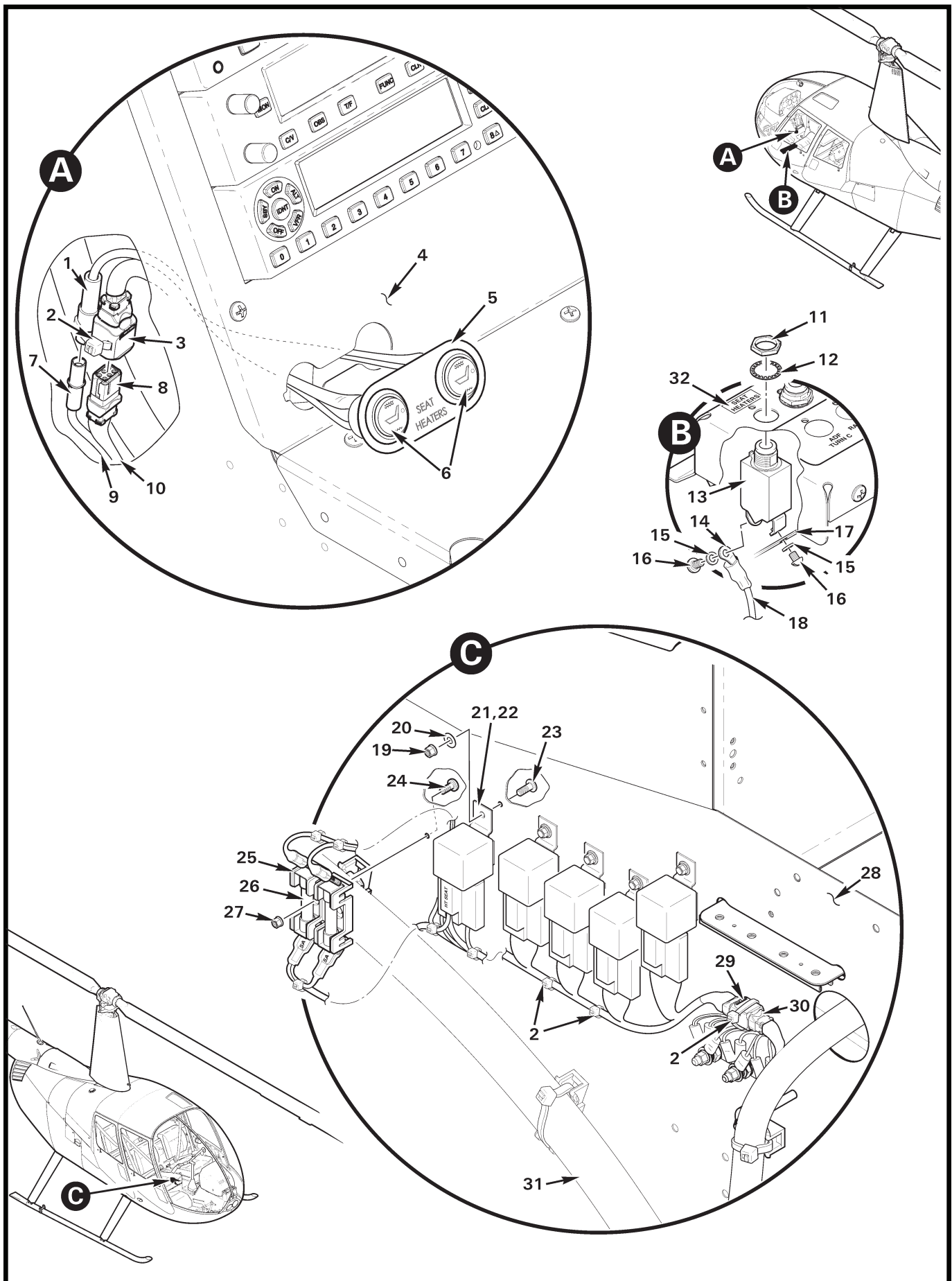

FIGURE AND INDEX NUMBER	PART NUMBER	DESCRIPTION	PARTS AVAIL	QTY PER ASSY
HEATED SEATS – WIRING INSTALLATION				
25-13-1	B263-10	Housing	X	1
	B263-1	Pin	X	1
2	MS3367-4-9	Ty-Rap	X	A/R
3	D269-5	Plug	X	1
4	D225	Avionics Panel (Ref)		
5	F372-4	Plate	X	1
6	F940-5	Switch Assembly (Incl items 1, 3, and 5)	X	1
7	B263-11	Housing	X	1
	B263-2	Socket	X	1
8	D269-6	Receptacle	X	1
9	-3145	Wire (Ref)		
10	-2416	Wire (Ref)		
	-2417	Wire (Ref)		
	-2418	Wire (Ref)		
	-2419	Wire (Ref)		
	-2420	Wire (Ref)		
	-2421	Wire (Ref)		
11	—	Nut	O	1
12	—	Lockwasher	O	1
13	B297-10	Circuit Breaker (10 amp, includes items 11, 12, 15, and 16)	X	1
14	B260-11	Terminal	X	1
15	—	Washer	O	2
16	—	Screw	O	2
17	A448	Bus Bar (Ref)		
18	-2413	Wire (Ref)		
19	MS21042L08	Nut	X	1
20	NAS1149FN816P	Washer	X	1
21	F940-6	Harness Assembly (Incl items 22, 24, and 25)	X	1
22	D260-4	Relay	X	1
	D260-6	Connector	X	1
23	MS27039C0806	Screw	X	1

NOTES

Continues

FIGURE AND INDEX NUMBER	PART NUMBER	DESCRIPTION	PARTS AVAIL	QTY PER ASSY
HEATED SEATS – WIRING INSTALLATION (Cont'd)				
25-13-24	MS35206-227*	Screw	X	1
25	D262-2	Fuse Block	X	1
26	D275-205	Fuse	X	2
27	MS21042L06*	Nut	X	1
28	C293-4	Panel (Ref)		
29	D269-1	Plug	X	1
30	D269-2	Receptacle (Ref)		
31	C859	Wire Harness (Ref)		
32	C654-64	Decal – “SEAT HEATERS”	X	1

NOTES * No thread exposed permissible.

Intentionally Blank

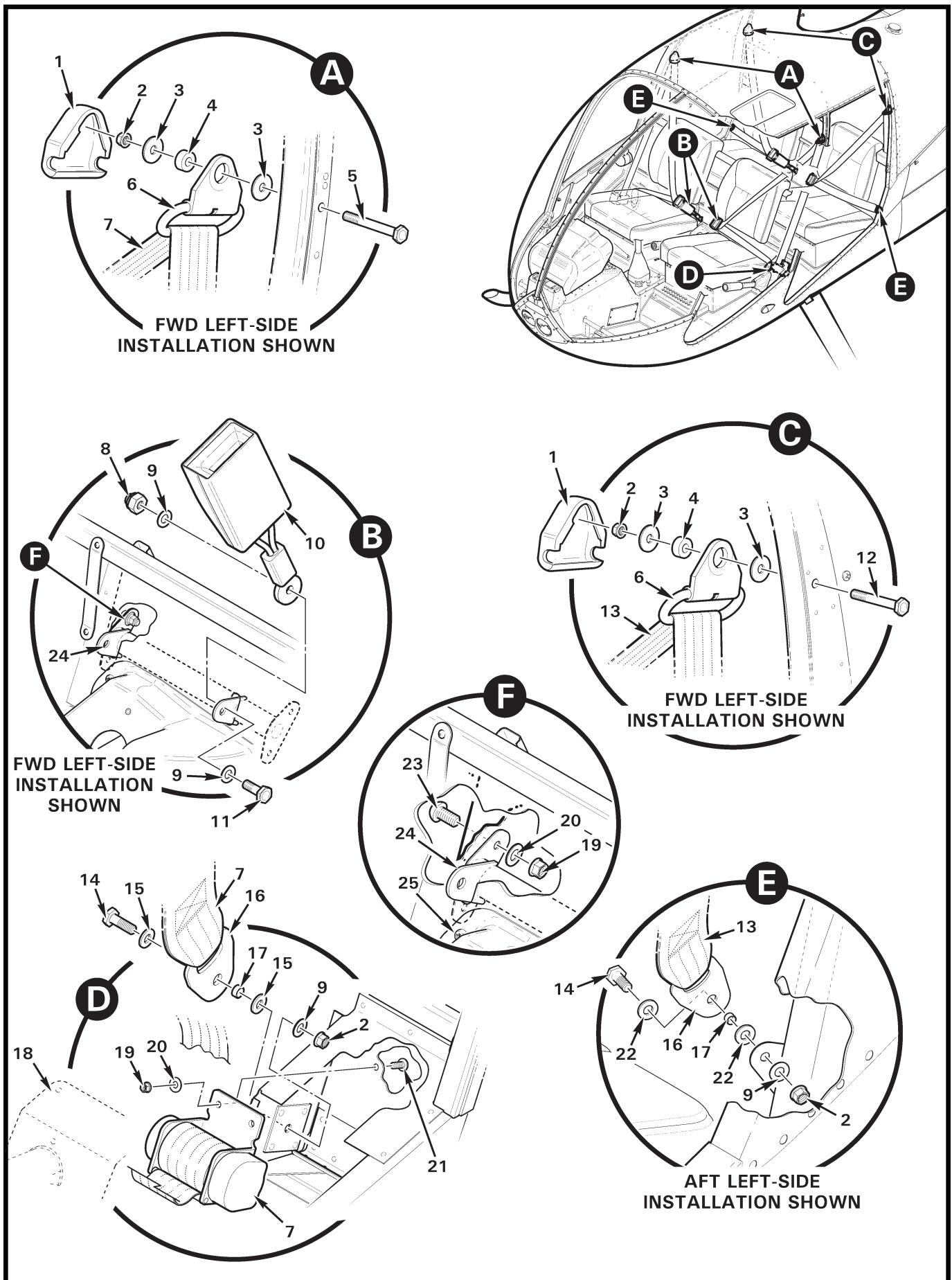

FIGURE AND INDEX NUMBER	PART NUMBER	DESCRIPTION	PARTS AVAIL	QTY PER ASSY
SEAT BELT INSTALLATION				
25-17-1	505798-1	Cover	X	4
2	D210-4	Nut	X	5
3	A141-14	Washer	X	4
4	A130-44	Spacer	X	4
5	NAS6604-22	Bolt	X	2
6	505561-1	Guide Assembly	O	1
7	F628-1	Harness Assembly - Fwd Connector (LH; includes items 1, 6, and 16. Supersedes item 26.)	X	1
8	B340-10	Nut	X	2
9	NAS1149F0432P	Washer	X	7
10	F628-7	Buckle Assembly	X	4
11	NAS6604-4	Bolt	X	4
12	NAS6604-18	Bolt	X	2
13	F628-3	Harness Assembly - Aft Connector (LH & RH; includes items 1, 6, and 16. Supersedes item 27.)	X	1
14	NAS6604-5	Bolt	X	3
15	NAS1149F0463P	Washer	X	2
16	500782-33	Fitting	O	1
17	A130-28	Spacer	X	3
18	C680-1	Cover Assembly (Ref, see Figure 6-5)		
19	D210-3	Nut	X	8
20	NAS1149F0332P	Washer	X	8
21	MS27039C1-08	Screw ([4] required on earlier R44s)	X	2
22	MS20002-4	Washer	X	4
23	MS27039C1-07	Screw ([4] required on earlier R44s)	X	6
24	C348-5	Anchor Assembly (forward shown)	X	1
	C315-9	Anchor Assembly (Ref; aft anchor. Not shown, see Figure 67-41.)		
25	C680-5	Cover Assembly (Ref, see Figure 6-5)		
26	C628-5	Harness Assembly - Aft Connector (LH & RH; includes items 1, 6, and 16)	O	1
27	C628-7	Harness Assembly - Aft Connector (LH & RH; includes items 1, 6, and 16)	O	2

NOTES

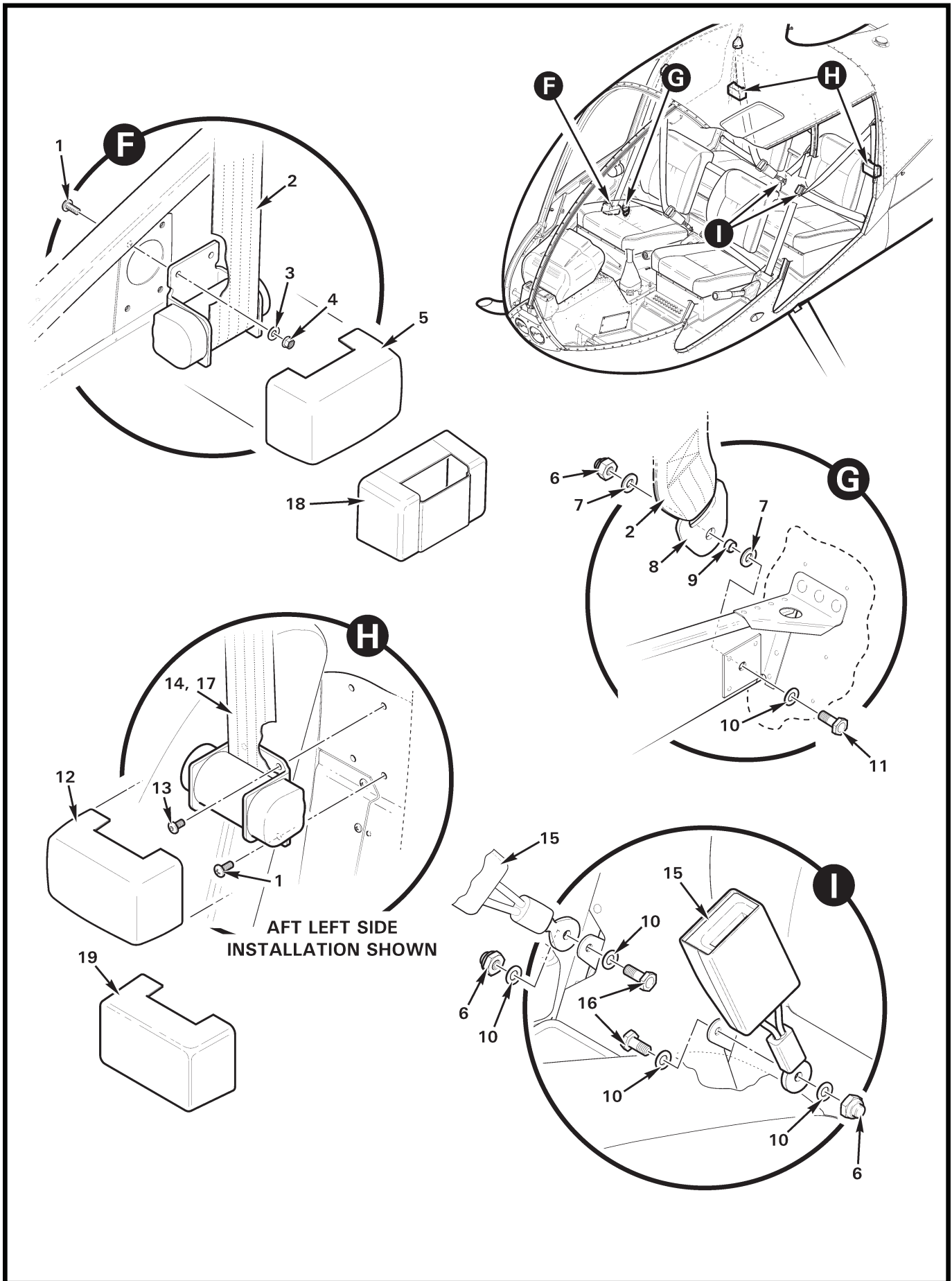

FIGURE AND INDEX NUMBER	PART NUMBER	DESCRIPTION	PARTS AVAIL	QTY PER ASSY
SEAT BELT INSTALLATION				
25-19-1	MS27039C1-09	Screw	X	8
2	C628-6	Harness Assembly – Fwd (RH, includes items 8 and 19)	X	1
3	NAS1149F0332P	Washer	X	4
4	D210-3	Nut	X	4
5	506354-5	Cover	O	1
6	B340-10	Nut	X	1
7	MS20002-4	Washer	X	2
8	500782-33	Fitting	O	1
9	A130-28	Spacer	X	1
10	NAS1149F0432P	Washer	X	5
11	NAS6604-5	Bolt	X	1
12	506354-3	Cover	O	1
13	A142-1	Screw	X	4
14	F628-3	Harness Assembly – Aft Connector (LH & RH, includes items 8 and 18)	X	2
15	F628-7	Buckle Assembly	X	2
16	NAS6604-4	Bolt	X	2
17	C628-7	Harness Assembly – Aft Connector (LH & RH, includes items 8 and 12; superseded by item 14)	O	2
18	505663-5	Cover (earlier R44s)	O	2
19	505663-3	Cover (earlier R44s)	X	1
NOTES				

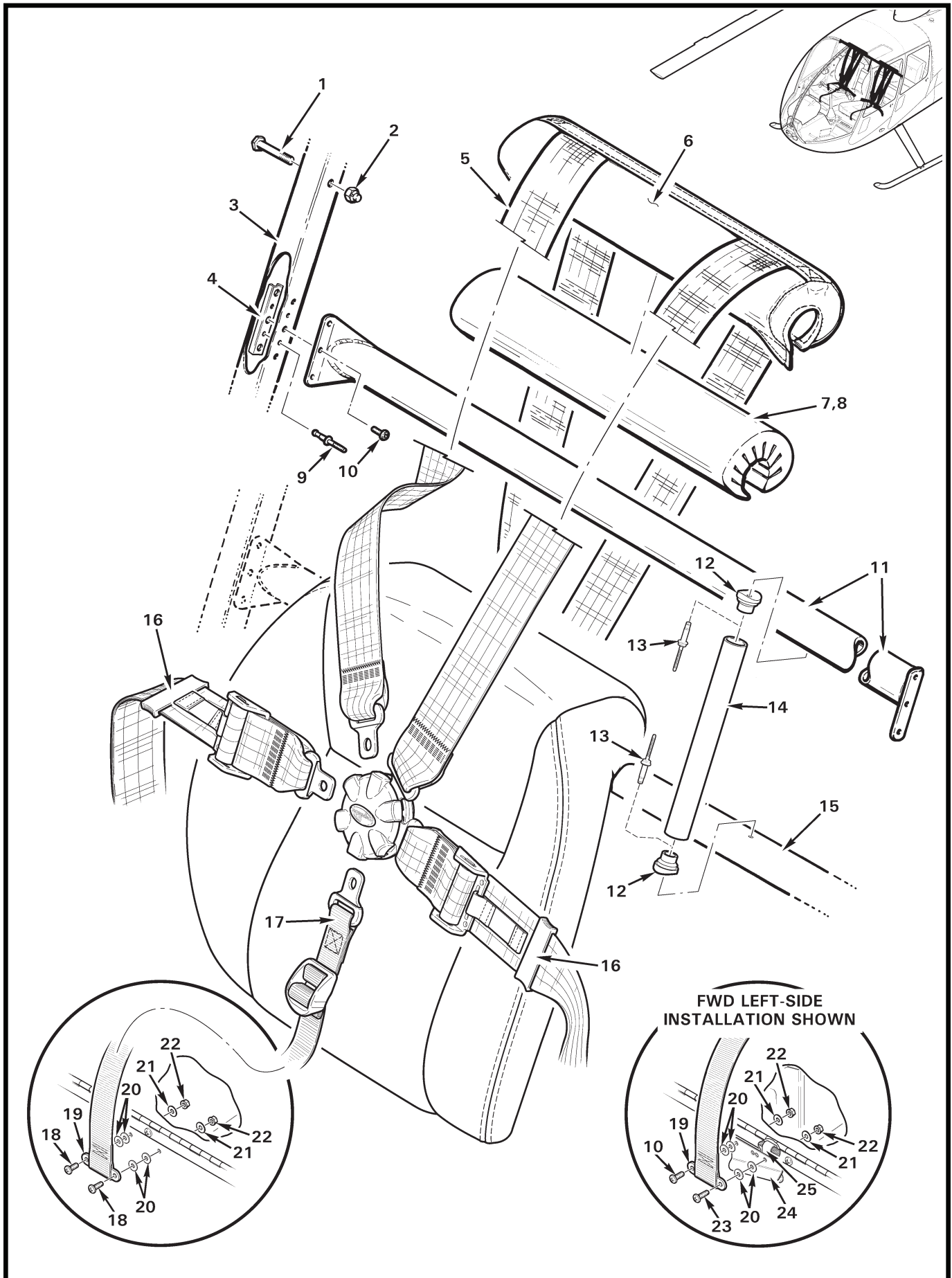

FIGURE AND INDEX NUMBER	PART NUMBER	DESCRIPTION	PARTS AVAIL	QTY PER ASSY
FIVE-POINT HARNESS INSTALLATION*				
25-21-1	NAS6604-17	Bolt	X	2
2	B340-10	Nut	X	2
3	C403-12	Post – Door (RH, Ref)		
	C403-11	Post – Door (LH, not shown; Ref)		
4	A738-28	Gang Channel	X	2
5	C627-6	Harness Assembly (LH and RH, Ref. Includes shoulder/lap/forward restraint belt(s), and inertia reel and cover, assembled. See also Figure 25-23.)		
6	C420-1**	Cover	X	2
7	C424-1	Padding (foam, install using item 8)	X	2
8	B270-8QT	Adhesive	X	A/R
9	NAS9302B-4-03	Rivet	X	4
10	MS27039C0807	Screw ([7] required when item 24 is installed)	X	6
11	C423-4	Tube	X	1
12	C421-5	Fitting	X	2
13	NAS9301B-5-06	Rivet	X	2
14	C421-2	Tube (Ref)		
15	C423-1	Tube (Ref)		
16	503964-1	Web Slide	O	2
17	—	Restraint Belt – Forward	O	1
18	MS27039C0806	Screw ([2] required when item 24 is installed)	X	4
19	F426-2	Anchor	X	2
20	NAS1149FN832P	Washer (under item 19)	X	8
21	NAS1149FN816P	Washer	X	2
22	MS21042L08	Nut	X	2
23	MS27039C0808	Screw (at LH forward, outboard position)	X	1
24	G196-7	Light Assembly (Ref, see also Figure 33-19)		
25	N-4-BK	Clamp (Ref)		

Code	Definition
GRL	Gray leather
GRV	Gray vinyl
TNL	Tan leather
TNV	Tan vinyl
CHL	Charcoal leather
CHV	Charcoal vinyl
BKV	Black vinyl

NOTES * Optional equipment. Refer to KI-155-1 for field installation.
 ** Refer to *chart* at the end of parts list when ordering. Include code after dash no., for example, C420-1 in black vinyl, order "C420-1BKV".

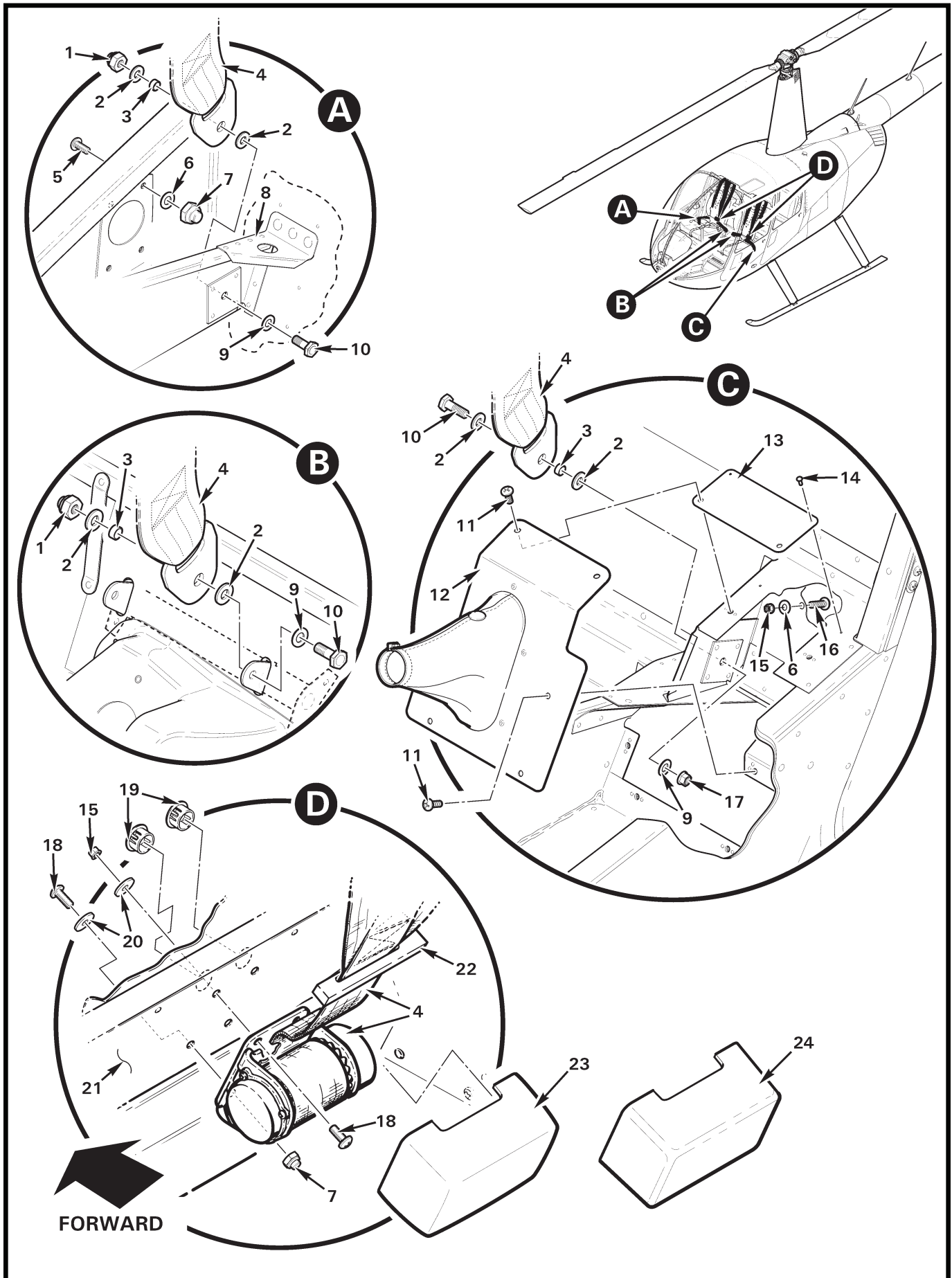

FIGURE AND INDEX NUMBER	PART NUMBER	DESCRIPTION	PARTS AVAIL	QTY PER ASSY
		FIVE-POINT HARNESS INSTALLATION*		
25-23-1	B340-10	Nut	X	3
2	MS20002-4	Washer	X	8
3	A130-28	Spacer	X	4
4	C627-6**	Harness Assembly (LH and RH; Ref. Includes items 22 and 23. See also Figure 25-21.)		
5	AN525-10R7	Screw	X	4
6	NAS1149F0332P	Washer	X	8
7	B340-8	Nut	X	6
8	C290-4	Seat Support (RH, Ref)		
9	NAS1149F0432P	Washer	X	4
10	NAS6604-5	Bolt	X	4
11	MS27039C0806	Screw (Ref)		
12	C680-1	Cover Assembly (Ref; see Figure 6-5)		
13	C680-4	Cover	X	1
14	MS20470AD3	Rivet	X	2
15	D210-3	Nut	X	8
16	MS27039C1-06	Screw	X	4
17	D210-4	Nut	X	1
18	MS27039C1-07	Screw	X	8
19	2663	Hole Plug	X	4
20	A141-17	Washer	X	8
21	C370-1	Panel (LH, Ref)		
22	C623-1	Block	O	1
	C623-2	Plate	O	1
	C623-3	Spring	O	1
23	506354-3	Cover	X	1
24	505663-3	Cover	X	1

NOTES * RH outboard and inboard position.
 ** Optional equipment. Refer to KI-155-1 for field installation.

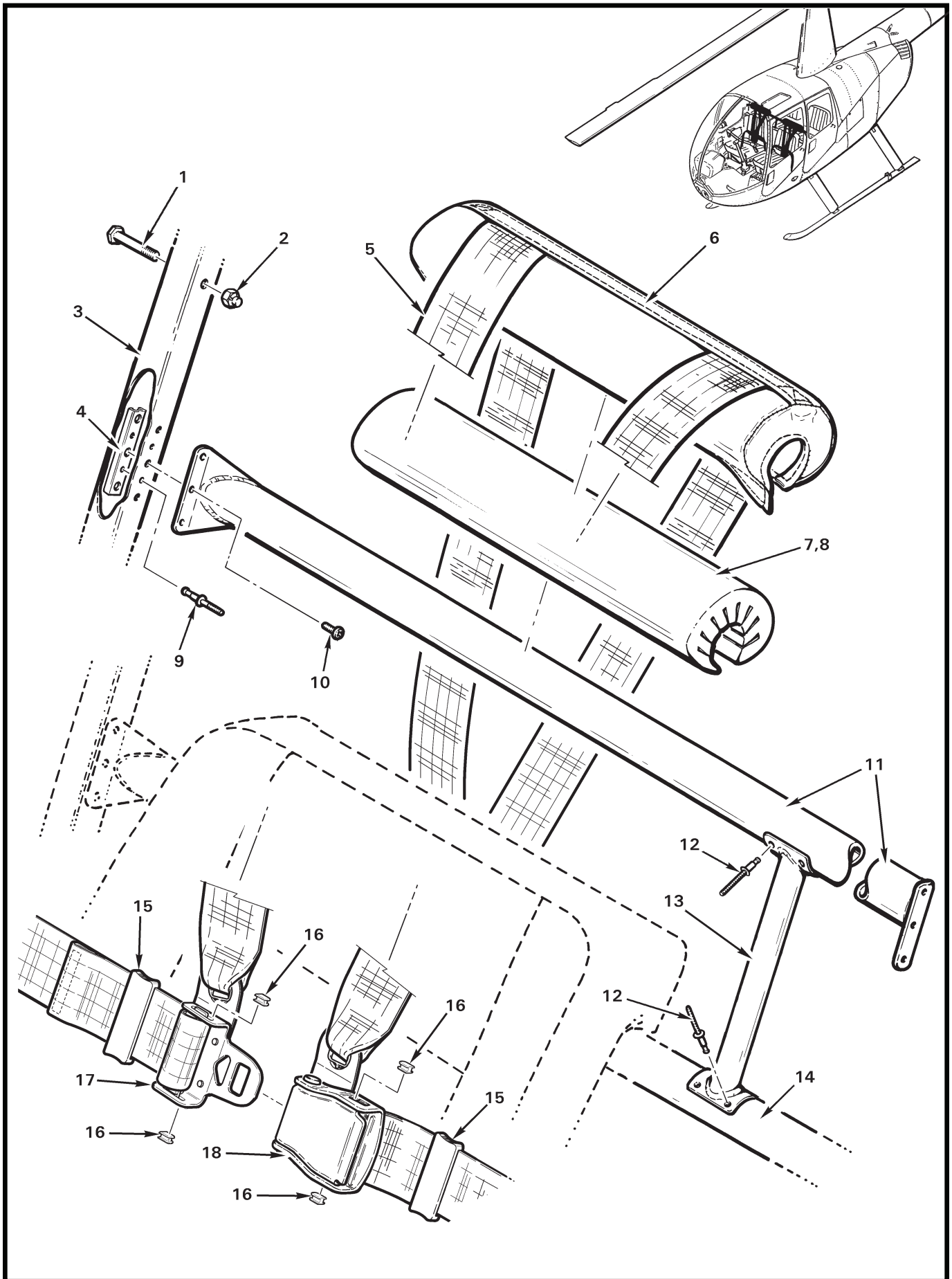

FIGURE AND INDEX NUMBER	PART NUMBER	DESCRIPTION	PARTS AVAIL	QTY PER ASSY
FOUR-POINT HARNESS INSTALLATION				
25-25-1	NAS6604-17	Bolt	X	2
2	B340-10	Nut	X	2
3	C403-12	Post – Door (RH, Ref)		
	C403-11	Post – Door (LH, not shown; Ref)		
4	A738-28	Gang Channel	X	2
5	C627-5*	Harness Assembly (LH and RH, Ref. Includes shoulder/lap belts, inertia reel and cover, and items 15 thru 18, assembled. See also Figure 25-27.)		
	C627-4*	Harness Assembly (LH and RH, Ref)		
6	C420-1**	Cover	X	2
7	C424-1	Padding (foam, install using item 8)	X	2
8	B270-8QT	Adhesive	X	A/R
9	NAS9302B-4-03	Rivet (2 each side)	X	4
10	MS27039C0807	Screw	X	6
11	C423-4	Tube	X	1
12	NAS9301B-4-02	Rivet	X	8
13	C421-1*	Tube (Ref)		
14	C423-1	Tube (Ref)		
15	503964-1	Web Slide	O	2
16	502913	Plug	X	4
17	—	Connector Assembly (Ref)		
18	—	Buckle Assembly (Ref)		

Code	Definition
GRL	Gray leather
GRV	Gray vinyl
TNL	Tan leather
TNV	Tan vinyl
CHL	Charcoal leather
CHV	Charcoal vinyl
BKV	Black vinyl

NOTES * No longer available. Refer to KI-155-2 to upgrade to five-point harness.
 ** Refer to chart at the end of parts list when ordering. Include code after dash no., for example, C420-1 in black vinyl, order "C420-1BKV".

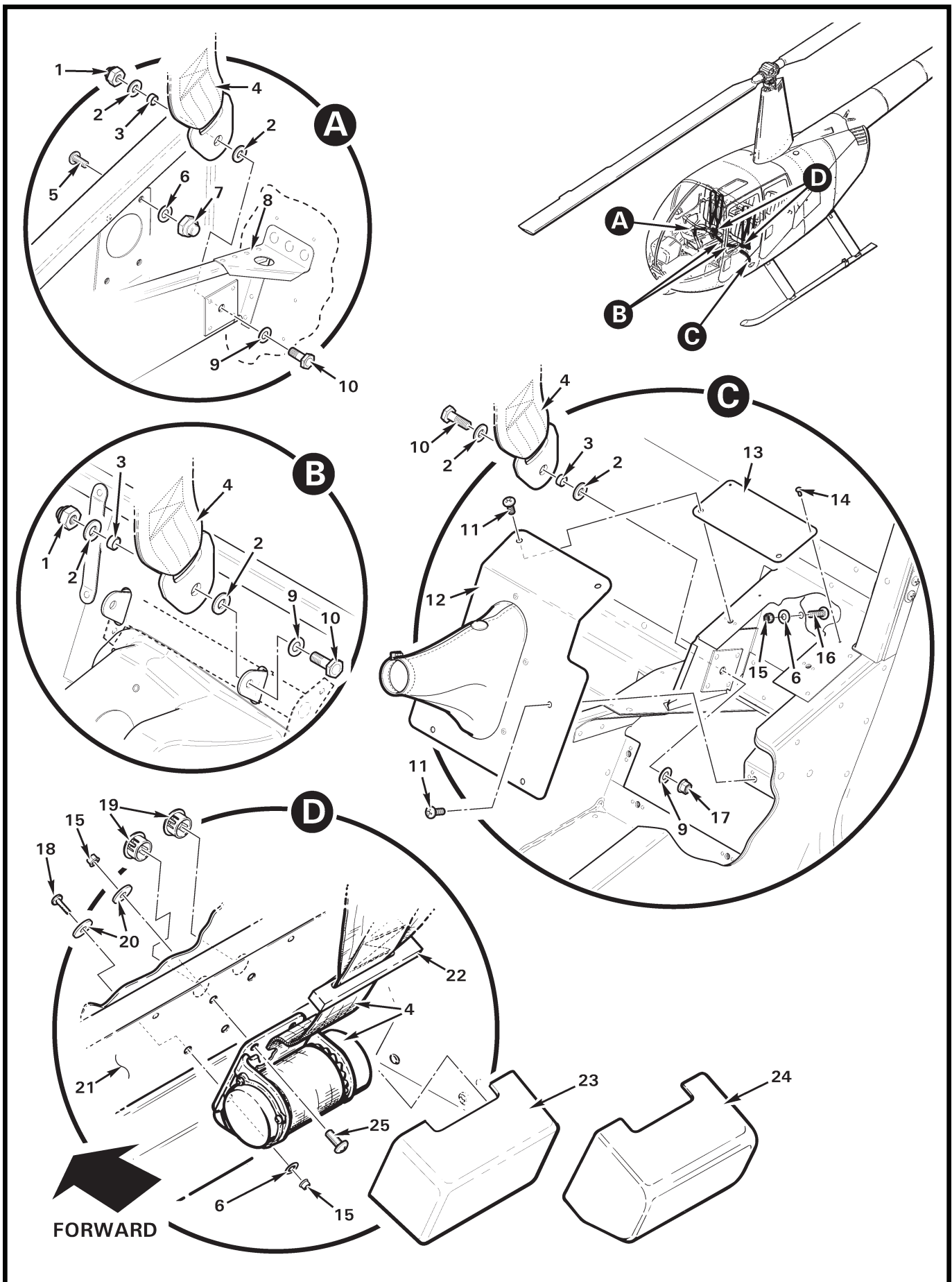

FIGURE AND INDEX NUMBER	PART NUMBER	DESCRIPTION	PARTS AVAIL	QTY PER ASSY
		FOUR-POINT HARNESS INSTALLATION*		
25-27-1	B340-10	Nut	X	3
2	MS20002-4	Washer (supersedes NAS1149F0463P)	X	8
3	A130-28	Spacer	X	3
4	C627-5**	Harness Assembly (Ref; LH and RH. Includes items 22 and 23. See also Figure 25-25.)		
	C627-4**	Harness Assembly (LH and RH, not shown; includes items 22 and 24. See also Figure 25-25.)		
5	AN525-10R7	Screw	X	4
6	NAS1149F0332P	Washer	X	12
7	B340-8	Nut ([2] at upper locations of standard harness inertia reel mount; [4] at upper and lower locations on earlier R44s, not shown)	X	8
8	C290-4	Seat Support (RH, Ref)		
9	NAS1149F0432P	Washer	X	4
10	NAS6604-5	Bolt	X	4
11	MS27039C0806	Screw (Ref)		
12	C680-1	Cover Assembly (Ref; see Figure 6-5)		
13	C680-4	Cover	X	1
14	MS20470AD3-3	Rivet	X	2
15	D210-3	Nut	X	12
16	MS27039C1-06	Screw	X	4
17	D210-4	Nut	X	1
18	MS27039C1-10	Screw	X	4
19	2663	Hole Plug	X	4
20	A141-17	Washer	X	8
21	C370-1	Panel (LH, Ref)		
22	C623-1	Block	O	1
	C623-2	Plate	O	1
	C623-3	Spring	O	1
23	505663-3	Cover	X	1
24	502224	Cover (earlier R44s)	O	1
25	MS27039C1-07	Screw	X	4

NOTES * Outboard and inboard position.
 ** No longer available. Refer to KI-155-2 to upgrade to five-point harness.

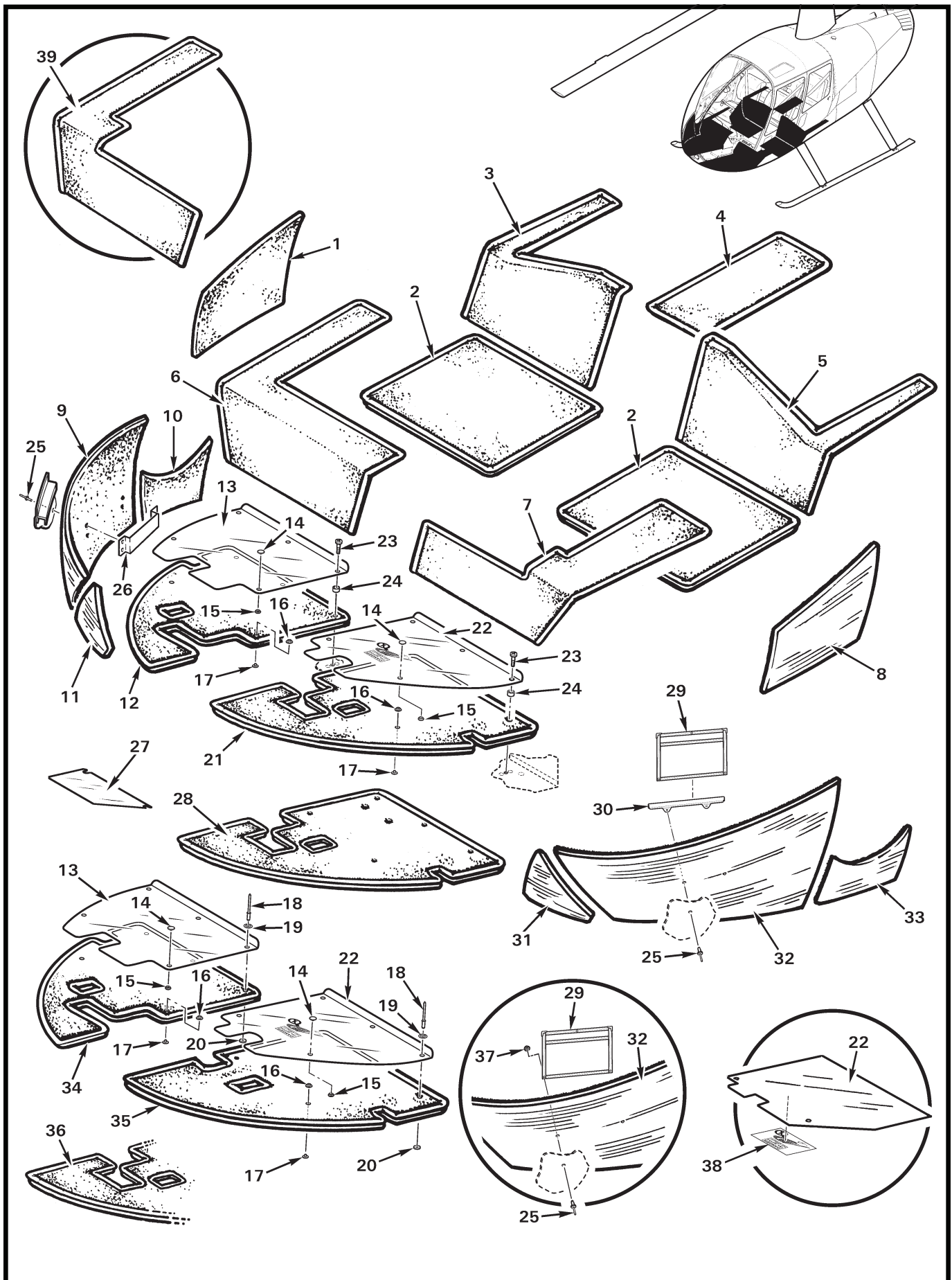

FIGURE AND INDEX NUMBER	PART NUMBER	DESCRIPTION	PARTS AVAIL	QTY PER ASSY
CARPET INSTALLATION*				
25-29-1	C469-16**	Carpet – Aft (RH)	X	1
2	C469-7**	Carpet Assembly – Aft (RH and LH, includes pad)	X	2
3	C469-34**	Carpet Assembly – Aft (RH)	X	1
	C469-6**	Carpet Assembly – Aft (RH, w/o aft heater; not shown)	X	1
4	C469-8**	Carpet Assembly (Tunnel).	X	1
5	C469-33	Carpet Assembly – Aft (LH, with aft heater)	X	1
	C469-5**	Carpet Assembly – Aft (LH, w/o aft heater; not shown)	X	1
6	C469-4**	Carpet Assembly – Fwd (RH)	X	1
7	C469-38	Carpet Assembly – Fwd (LH, for use with raised C.B. panel) . .	X	1
	C469-3**	Carpet Assembly – Fwd (LH, for use with flush C.B. panel; not shown)	X	1
8	C469-15**	Carpet – Aft (LH)	X	1
9	C469-12**	Carpet (RH)	X	1
10	C469-14**	Carpet (RH)	X	1
11	C469-10**	Carpet (RH)	X	1
12	C469-46**	Carpet Assembly – Fwd (RH, with screwed-down scuff plate. Includes items 13, 16, 17, and pad.)	X	1
13	C469-25	Scuff Plate Assembly (RH, Incl items 14, 15, and 41)	X	1
14	MS27981-1B	Button	X	4
15	MS27981-3B	Socket	X	4
16	MS27981-4B	Stud	X	4
17	MS27981-5B	Eyelet	X	4
18	B204-4	Rivet (blind)	X	6
19	A3236-012-193	Washer	X	6
20	90183A213	Washer	X	6
21	C469-45**	Carpet Assembly – Fwd (LH, with screwed-down scuff plate. Includes items 16, 17, 22, and pad.)	X	1
22	C469-31	Scuff Plate Assembly (LH, Incl items 14, 15, 39, and 41) . . .	X	1
23	MS27039C0810	Screw	X	6
24	A130-33	Spacer	X	6
25	B204-2	Rivet (blind; [4] rivets installed through item 26, [2] installed through items 29 and 30)	X	6
26	A745-1	Strap	X	1
27	B392-2	Cover (install when co-pilot pedals are removed)	X	1
28	C469-53	Carpet Assembly (LH, with LH heater outlet, floor intercom switches)	X	1

NOTES * Available in dark charcoal only.
 ** Install using item 40.

Continues

FIGURE AND INDEX NUMBER	PART NUMBER	DESCRIPTION	PARTS AVAIL	QTY PER ASSY
CARPET INSTALLATION* (Cont'd)				
25-29-29	13-07900	License Holder	X	1
30	B632-1	Channel	X	1
31	C469-9**	Carpet (LH)	X	1
32	C469-11**	Carpet (LH)	X	1
33	C469-13**	Carpet (LH)	X	1
34	C469-2**	Carpet Assembly (RH, with riveted scuff plate. Includes items 13, 16 thru 20, and pad.)	X	1
35	C469-1**	Carpet Assembly (LH, without LH heater outlet. Includes items 16 thru 20, 22, and pad.)	X	1
36	C469-37**	Carpet Assembly (LH, with LH heater outlet. Includes items 16 thru 20, 22, and pad)	X	1
37	NAS620-5	Washer	X	2
38	A654-85	Decal – "Danger" (earlier R44s; replace with C469-31 scuff plate)	O	1
39	C469-43**	Carpet Assembly – Fwd (RH, for use with raised Aux C.B. panel)	X	1
40	B270-8QT	Adhesive	X	A/R
* * *				
41	C469-1K1	Installation Hardware Kit (Incl items 42 thru 46; for use with riveted scuff plate)	X	1
42	90183A213	Washer	X	3
43	A3236-012-193	Washer	X	3
44	B204-4	Rivet (blind)	X	3
45	MS27981-4B	Stud	X	2
46	MS27981-5B	Eyelet	X	2
* * *				
47	C469-1K2	Installation Hardware Kit (Incl items 48 [3 each] and 49 [3 each]; for use with 3-screw scuff plate)	X	1
48	A130-33	Spacer	X	A/R
49	AN525-832R10	Screw	X	A/R
* * *				
50	C469-1K3	Installation Hardware Kit (Incl items 48 [5 each] and 49 [5 each]; for use with 5-screw scuff plate)	X	1

NOTES * Available in dark charcoal only.
 ** Install using item 40.

Intentionally Blank

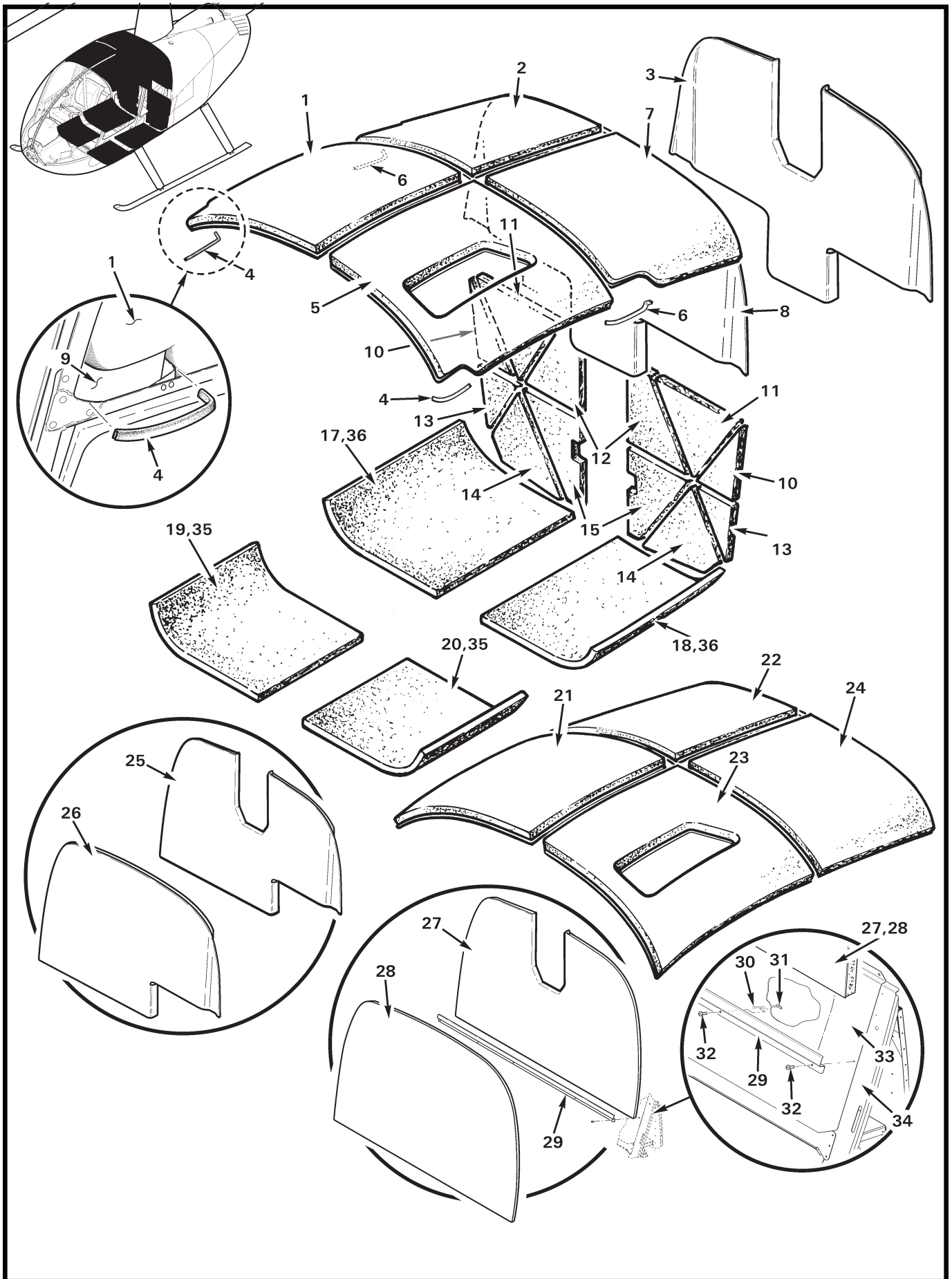

FIGURE AND INDEX NUMBER	PART NUMBER	DESCRIPTION	PARTS AVAIL	QTY PER ASSY
HEADLINER AND INSULATION INSTALLATION				
25-33-1	C003-21*	Insulation** (forward, RH; for ships with hand-holds)	X	1
2	C003-19*	Insulation** (aft, RH; for ships with hand-holds)	X	1
3	C003-18*	Insulation** (aft cabin; for air conditioned ships)	X	1
4	C212-1	Trim (hand-hold; forward, LH and RH)	X	2
5	C003-22*	Insulation** (forward, LH; for ships with hand-holds)	X	1
6	C212-2	Trim (hand-hold; aft, LH and RH)	X	2
7	C003-20*	Insulation** (aft, LH; for ships with hand-holds)	X	1
8	C003-2*	Insulation** (aft cabin; for non-air conditioned ships)	X	1
9	C212-3	Patch** (installed behind items 4 and 6; [4] R44 and R44 II, [2] R44 Cadet)	X	A/R
10	C003-14	Insulation**	X	2
11	C003-13	Insulation**	X	2
12	C003-12	Insulation**	X	2
13	C003-15	Insulation**	X	2
14	C003-16	Insulation**	X	2
15	C003-17	Insulation**	X	2
16	B270-8QT	Adhesive	X	A/R
17	F470-4	Liner (aft, RH baggage compartment; replaces C008-7 insulation)	X	1
18	F470-3	Liner (aft, LH baggage compartment; replaces C008-7 insulation)	X	1
19	F470-2	Liner (forward, RH baggage compartment; replaces C003-8 insulation)	X	1
20	F470-1	Liner (forward, LH baggage compartment; replaces C003-8 insulation)	X	1
21	C003-5*	Insulation** (forward, RH; for ships <u>without</u> hand-holds)	X	1
22	C003-3*	Insulation** (aft, RH; for ships <u>without</u> hand-holds)	X	1
23	C003-6*	Insulation** (forward, LH; for ships <u>without</u> hand-holds)	X	1
24	C003-4*	Insulation** (aft, LH; for ships <u>without</u> hand-holds)	X	1
25	D598-4*	Insulation** (aft cabin; for ENG/Police air conditioned ships)	X	1
26	D598-2*	Insulation** (aft cabin; for ENG/Police non-air conditioned ships)	X	1
27	C003-25*	Insulation** (aft cabin; for Cadet air conditioned ships)	X	1
28	C003-24*	Insulation** (aft cabin; for Cadet non-air conditioned ships)	X	1
29	D670-6	Trim (replaces C474-3 trim)	X	1
30	MS20426AD3	Rivet	X	4

NOTES * Refer to *chart* at the end of parts list when ordering. Include code after dash no., for example, C003-21 in tan, order "C003-21TN".

** Install using item 16.

FIGURE AND INDEX NUMBER	PART NUMBER	DESCRIPTION	PARTS AVAIL	QTY PER ASSY						
HEADLINER AND INSULATION INSTALLATION (Cont'd)										
25-33-31	MS21069L08K	Nutplate (two places, LH and RH)	X	2						
32	MS27039C0806	Screw	X	6						
33	C465-1	Panel (Ref, LH; see Figure 25-1)								
34	C015	Cabin Assembly (Ref)								
35	C003-8	Insulation (earlier R44s; forward baggage compartment)	O	2						
36	C003-7	Insulation (earlier R44s; aft baggage compartment)	O	2						
<table border="1"> <thead> <tr> <th data-bbox="794 667 914 716">Code</th> <th data-bbox="914 667 1128 716">Definition</th> </tr> </thead> <tbody> <tr> <td data-bbox="794 716 914 758">GR</td> <td data-bbox="914 716 1128 758">Gray</td> </tr> <tr> <td data-bbox="794 758 914 802">TN</td> <td data-bbox="914 758 1128 802">Tan</td> </tr> </tbody> </table>					Code	Definition	GR	Gray	TN	Tan
Code	Definition									
GR	Gray									
TN	Tan									

NOTES

Intentionally Blank

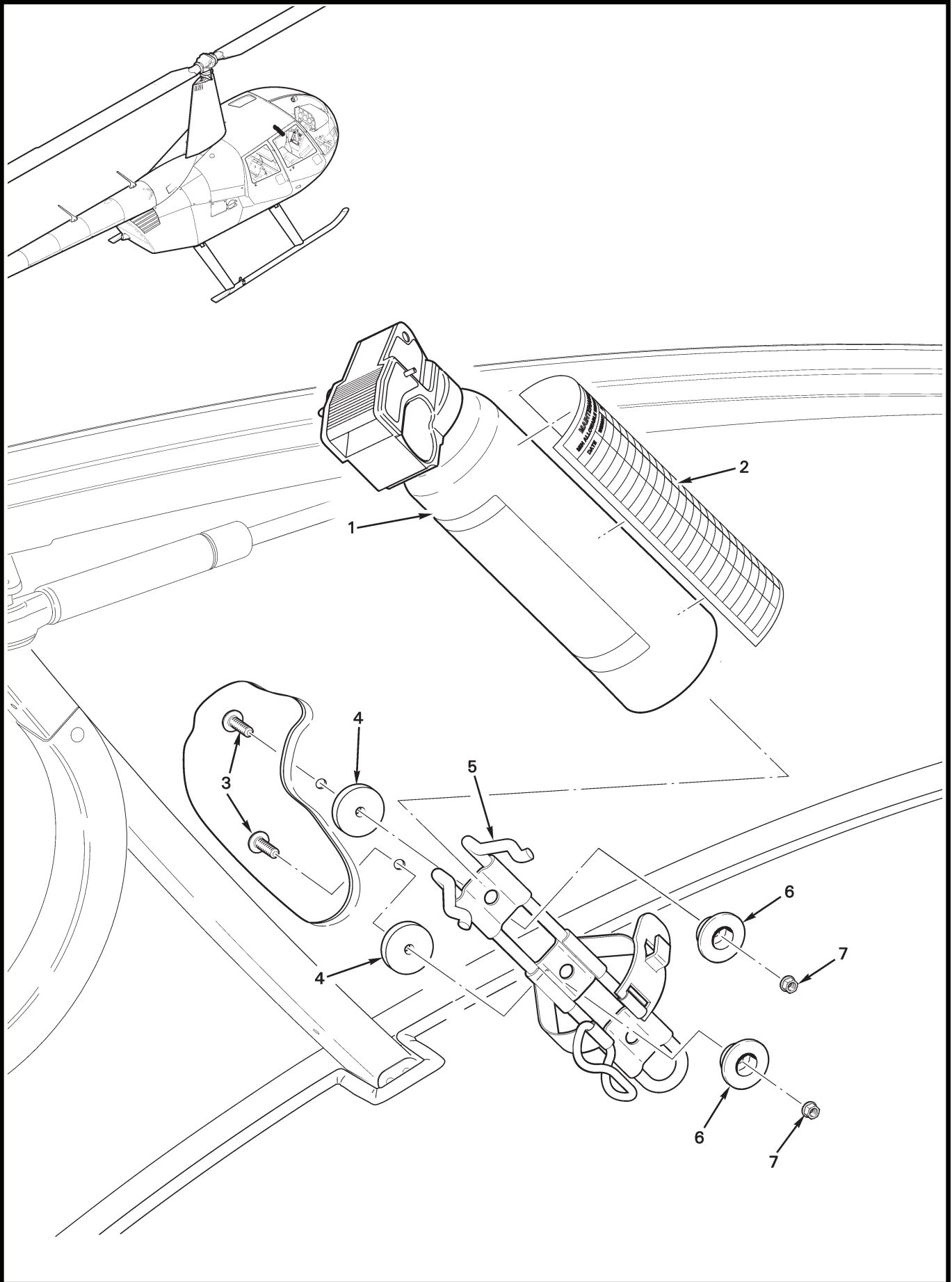

FIGURE AND INDEX NUMBER	PART NUMBER	DESCRIPTION	PARTS AVAIL	QTY PER ASSY	
FIRE EXTINGUISHER INSTALLATION					
25-37-1	B381-1	Fire Extinguisher Assembly (includes RT-A400 Fire Extinguisher and item 2)	X	1	
	RT-A400	Fire Extinguisher (14-oz. capacity)	O	1	
	2	G654-15	Decal – Maintenance Log	X	1
	3	AN526C832R_	Screw (select screw length to provide 0.00–0.06 in. exposed thread)	X	2
	4	C130-54	Spacer	X	2
	5	B381-3	Bracket	X	1
	6	G220-1	Retainer	X	2
	7	MS21042L08	Nut	X	2

NOTES

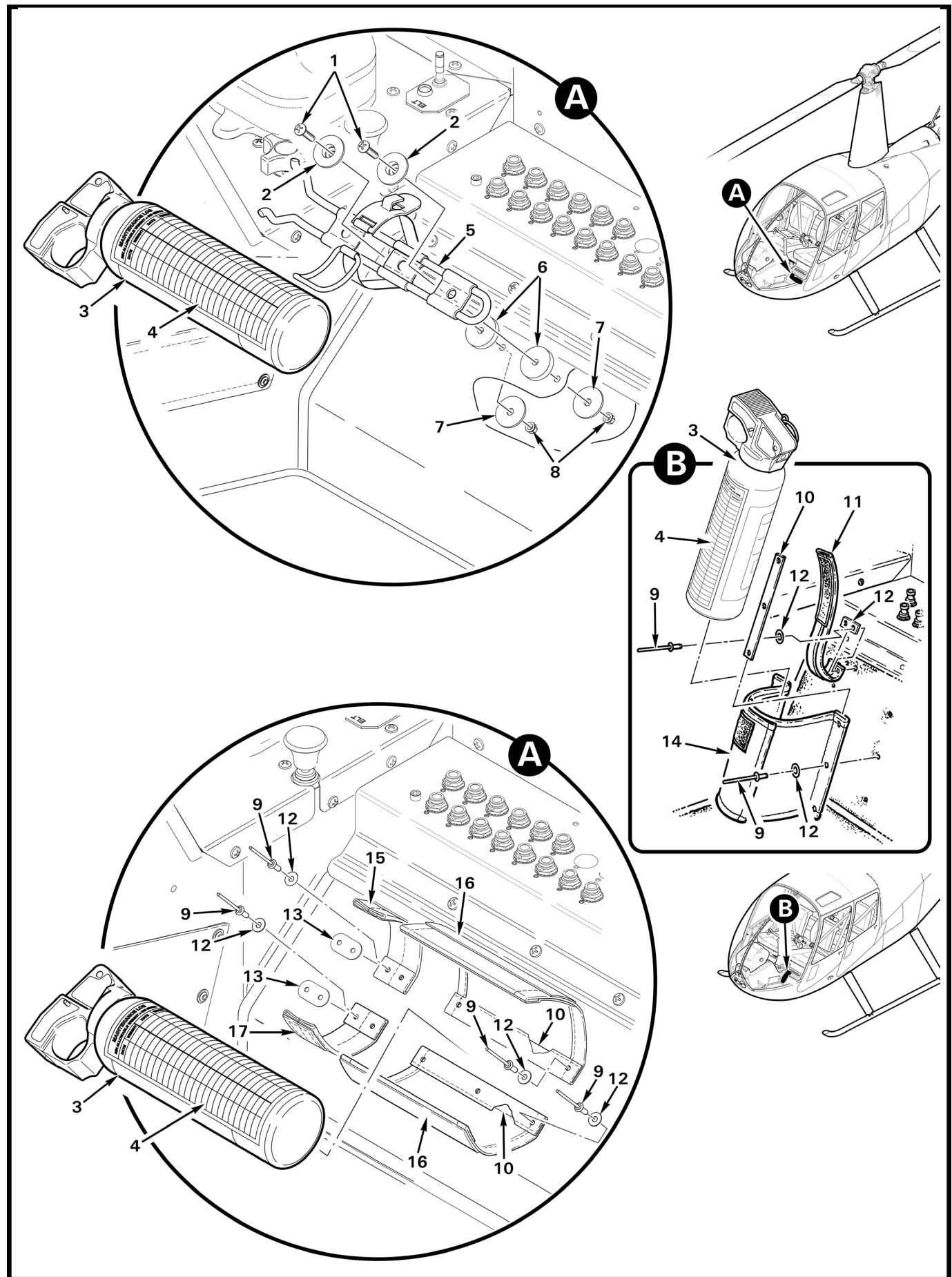

FIGURE AND INDEX NUMBER	PART NUMBER	DESCRIPTION	PARTS AVAIL	QTY PER ASSY
FIRE EXTINGUISHER INSTALLATION				
25-39-1	MS27039C0810	Screw	X	2
2	G220-1	Retainer	X	2
3	B381-1	Fire Extinguisher (Halon, 14-oz. capacity; includes item 4) . . .	X	1
	RT-A400	Fire Extinguisher (14-oz. capacity)	O	1
4	G654-15	Decal – Maintenance Log	X	1
5	B381-3	Bracket	X	1
6	C130-54	Spacer	X	2
7	AN970-3	Washer	X	2
8	MS21042L08	Nut	X	2
9	B204-3	Rivet**	X	10
10	A913-1	Strip**	X	2
11	B219-4*	Strap Assembly	X	1
12	NAS1149FN616P	Washer**	X	10
13	A913-2	Strip**	X	2
14	B219-3*	Pocket Assembly** (2-piece hook and loop)	X	1
15	B219-6*	Strap Assembly** (loop)	X	1
16	B219-5*	Pocket Assembly** (2-piece hook and loop)	X	1
17	B219-7*	Strap Assembly** (hook)	X	1

Code	Definition
GR	Gray
TN	Tan
BLK	Black

NOTES * Refer to *chart* at the end of parts list when ordering. Include code after dash no., for example, B219-4 in black, order "B219-4BLK".

** Earlier R44s.

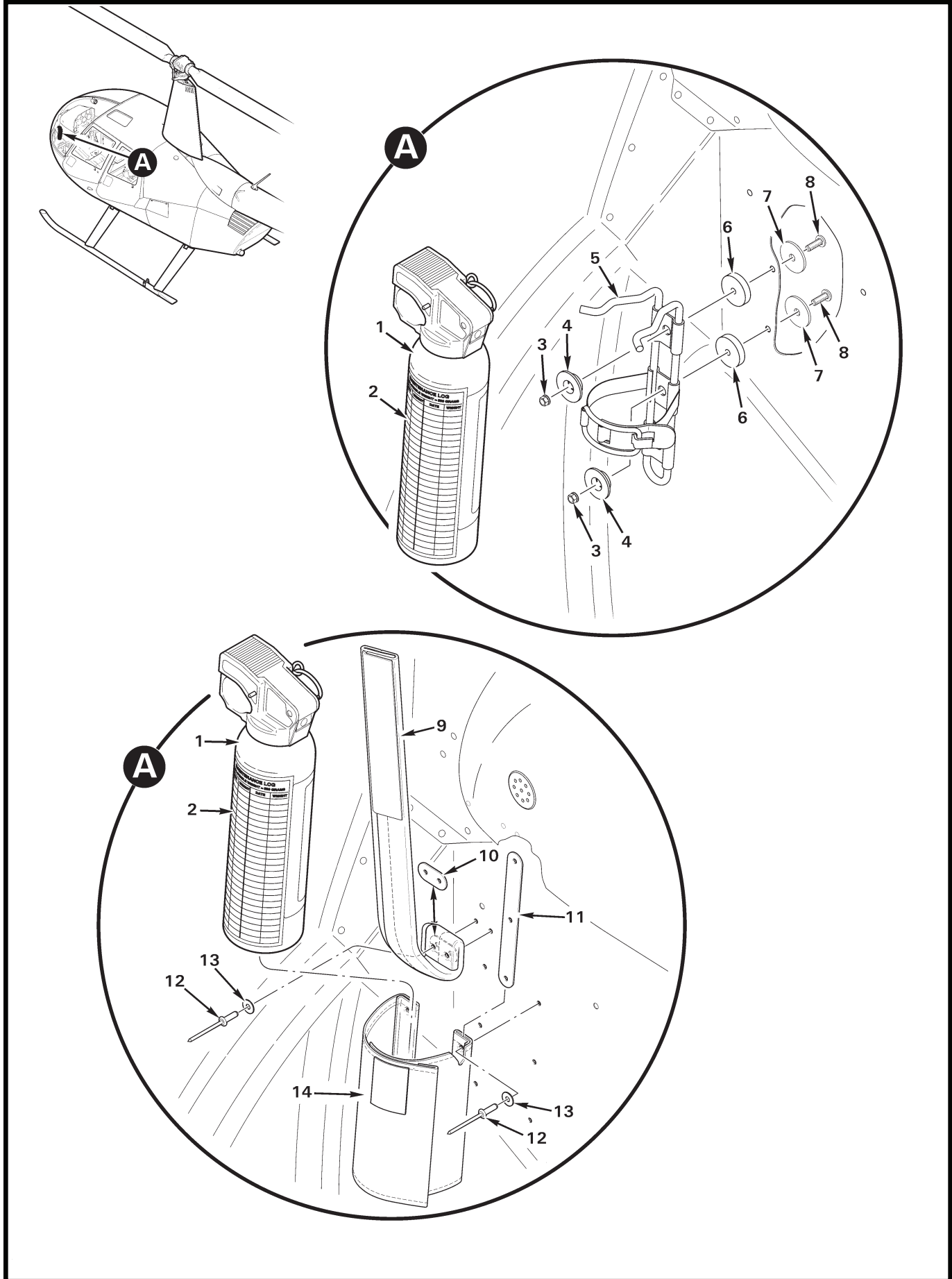

FIGURE AND INDEX NUMBER	PART NUMBER	DESCRIPTION	PARTS AVAIL	QTY PER ASSY
FIRE EXTINGUISHER INSTALLATION				
25-41-1	B381-1	Fire Extinguisher Assembly (includes RT-A400 Fire Extinguisher and item 2)	X	1
	RT-A400	Fire Extinguisher (14-oz. capacity)	O	1
2	G654-15	Decal – Maintenance Log	X	1
3	MS21042L08	Nut	X	2
4	G220-1	Retainer	X	2
5	B381-3	Bracket	X	1
6	C130-54	Spacer	X	2
7	AN970-3	Washer	X	2
8	MS27039C0810	Screw	X	2
9	B219-4*	Strap Assembly**	X	1
10	A913-2	Strip**	X	1
11	A913-1	Strip**	X	2
12	B204-2	Rivet	X	8
13	NAS1149FN616P	Washer	X	8
14	B219-3*	Pocket Assembly**	X	1

Code	Definition
GR	Gray
TN	Tan
BLK	Black

NOTES * Refer to *chart* at the end of parts list when ordering. Include code after dash no., for example, B219-4 in black, order "B219-4BLK".

** Earlier R44s.

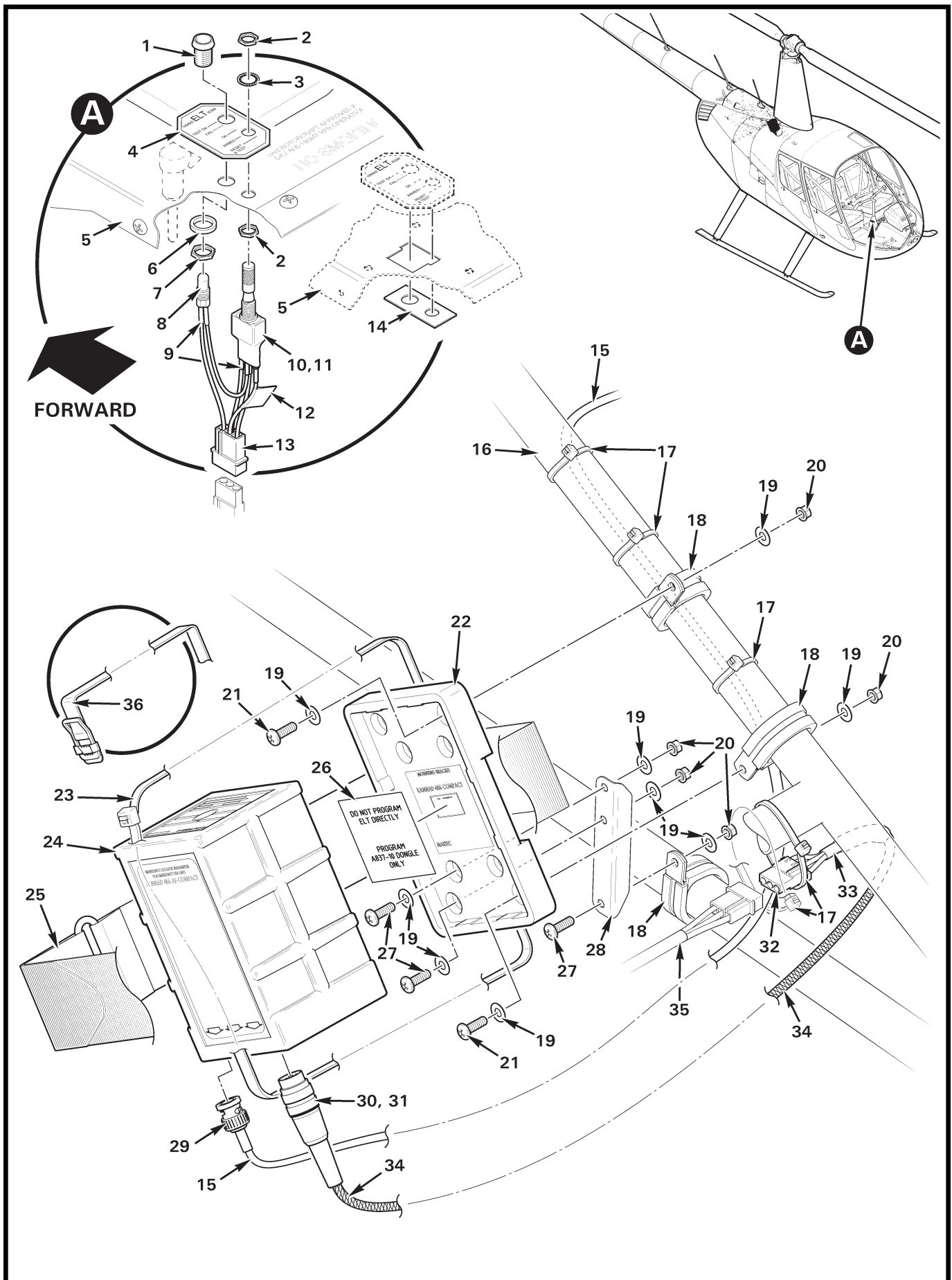

FIGURE AND INDEX NUMBER	PART NUMBER	DESCRIPTION	PARTS AVAIL	QTY PER ASSY
KANNAD ELT INSTALLATION*				
25-41B-1	—	Mount – LED	O	1
2	—	Nut	O	2
3	—	Lockwasher	O	1
4	—	Panel	O	1
5	C444	Cover – Cyclic (Ref; current and previous [dashed] configurations)		
6	—	Ring	O	1
7	—	Nut	O	1
8	—	LED (bi-polar, red)	O	1
9	B158-1	Heat Shrink	X	A/R
10	—	Switch (remote control, 3-position, locking)	O	1
11	F837-3	Switch Assembly (On, Reset; includes items 1 thru 4, 6 thru 10, 12, 13, and wires; assembled)	X	1
12	—	Production Stamp	O	1
13	B263-14	Housing	X	1
	B263-1	Pin	X	3
14	A837-3**	Plate – Backing	X	1
15	B274-518	Cable – Coaxial	X	A/R
16	C020	Frame – Upper (Ref)		
17	MS3367-5-9	Ty-Rap	X	A/R
18	MS21919WDG16	Clamp	X	3
19	NAS1149F0316P	Washer	X	8
20	D210-3	Nut	X	5
21	MS27039C1-08	Screw	X	2
22	S1840502-01***	Bracket – Mount (ELT)	X	1
23	MS3367-6-0	Ty-rap	X	1
24	S1851501-02***	ELT (Integra 406 AF-H)	X	1
25	—	Strap (included with item 24)	O	1
26	F654-25	Decal (dongle programming instructions)	X	1
27	MS27039C1-07	Screw	X	3
28	C837-5	Angle	X	1
29	5225395-6	Plug (BNC)	X	1

NOTES * Optional Equipment. Refer to KI-179-6 and KI-179-8 for field installations.

** Earlier R44s.

*** Kannad part no.

Continues

FIGURE AND INDEX NUMBER	PART NUMBER	DESCRIPTION	PARTS AVAIL	QTY PER ASSY
KANNAD ELT INSTALLATION (Cont'd)				
25-41B-30	A837-10	Harness Assembly (Incl items 31 thru 34, and wires; assembled)	X	1
31	S1820514-01*	Dongle (requires programming)	O	1
32	B263-15	Housing	X	1
	B263-2	Socket	X	3
33	B158-3	Heat Shrink	X	A/R
	B158-1**	Heat Shrink (this location)	X	A/R
34	B266-4	Sleeving	X	A/R
35	C859 or C059	Harness Assembly (Ref)		
36	D693-4**	Strap Assembly	O	1

37	KI-179-6	R44 Kannad AF Integra Kit (optional)	X	A/R
38	KI-179-8	R44 Kannad AF Integra Provision Kit (does not include ELT; optional)	X	A/R

NOTES * Kannad part no.
 ** Earlier R44s.

Intentionally Blank

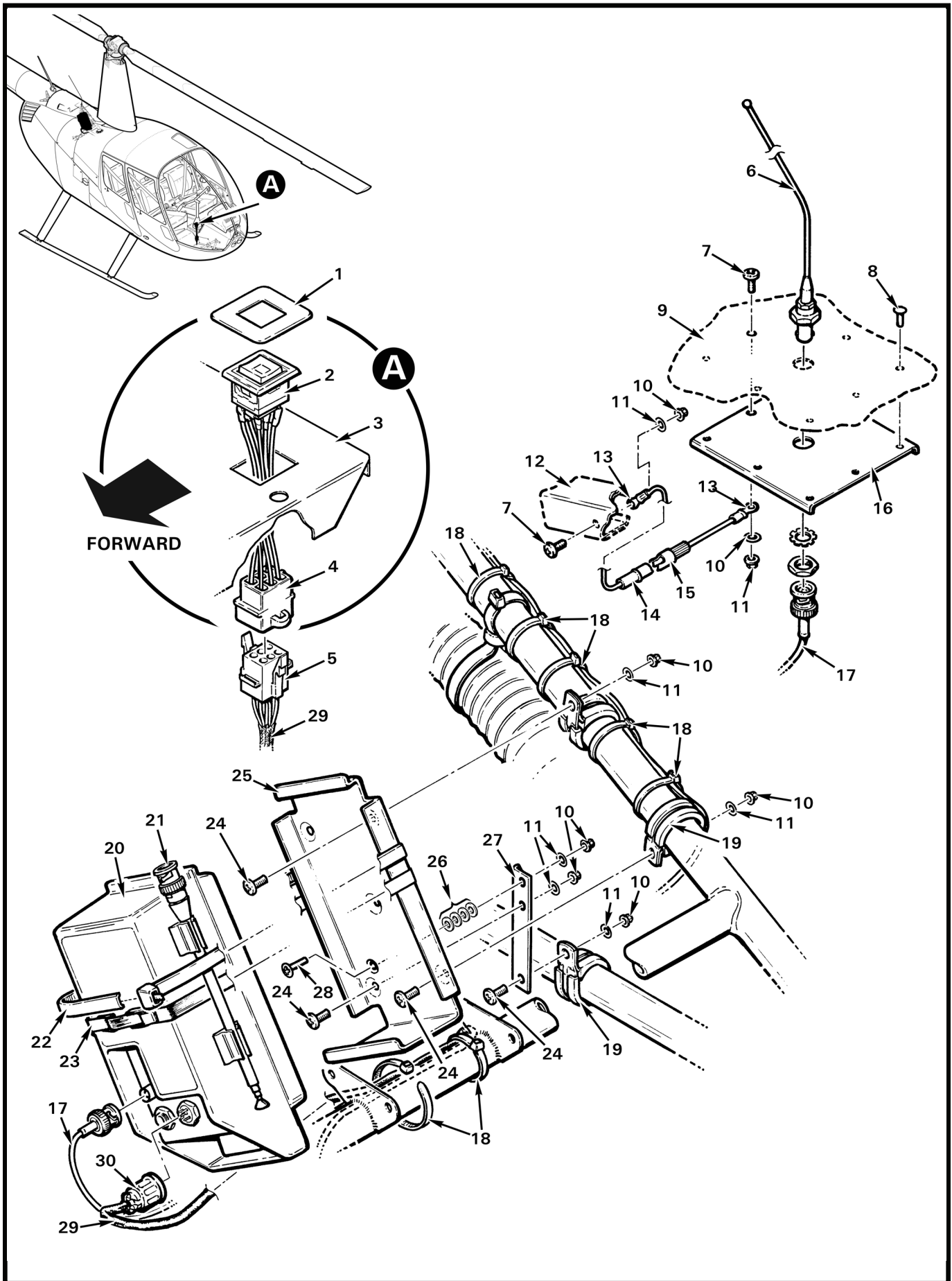

FIGURE AND INDEX NUMBER	PART NUMBER	DESCRIPTION	PARTS AVAIL	QTY PER ASSY
POINTER ELT AND ANTENNA INSTALLATION				
25-45-1	—	Decal – “On, Reset”	O	1
2	C830-1A	Switch Sub-Assembly (On, Reset; includes MLW-3029* switch, heat shrink, wires, and item 1)	X	1
3	C444	Cover – Cyclic (Ref, see also Figure 67-1)		
4	B263-18	Housing	X	1
	B263-1	Pin	X	6
5	B263-19	Housing	X	1
	B263-2	Socket	X	6
6	3001*	Antenna (external mount, includes nut and washer)	O	1
7	MS27039C0806	Screw	X	2
8	MS20470AD3-4	Rivet	X	7
9	C706-1	Cowling (Ref, see Figure 53-13)		
10	MS21042L08	Nut	X	7
11	NAS1149FN816P	Washer	X	7
12	C245-1	Channel – Aux Tank Assembly (Ref)		
13	B260-3	Terminal	X	2
14	B263-11	Housing	X	1
	B263-2	Socket	X	1
15	B263-10	Housing	X	1
	B263-1	Pin	X	1
16	A830-3	Doubler	X	1
17	3002*	Cable – Antenna (coax)	O	1
18	MS3367-5-9	Ty-Rap	X	A/R
19	MS21919WDG16	Clamp	X	3
20	3000-10*	ELT Unit (U.S. and other areas except Canada)	O	1
	4000-10*	ELT Unit	O	1
21	2006*	Antenna (secondary; telescopic)	O	1
22	B359-1	Ty-Rap	O	1
23	—	Strap	O	1
24	MS27039C0807	Screw	X	4
25	—	Mounting Bracket	O	1

NOTES * Pointer part no.

Continues

FIGURE AND INDEX NUMBER	PART NUMBER	DESCRIPTION	PARTS AVAIL	QTY PER ASSY
POINTER ELT AND ANTENNA INSTALLATION (Cont'd)				
25-45-26	NAS1149FN832P	Washer	X	4
27	C830-3	Angle	X	1
28	MS24694-S5	Screw	X	1
29	KI-89C	Wire Harness (Incl items 30 thru 32, wires, and wire shield/jacket)	O	1
30	126-223*	Connector	O	1
31	B267-3**	Terminator	X	1
32	B158-1**	Heat Shrink (3/32 in. dia.)	X	A/R
	B158-3**	Heat Shrink (3/16 in. dia.)	X	A/R

NOTES * Pointer part no.
 ** Not shown.

Intentionally Blank

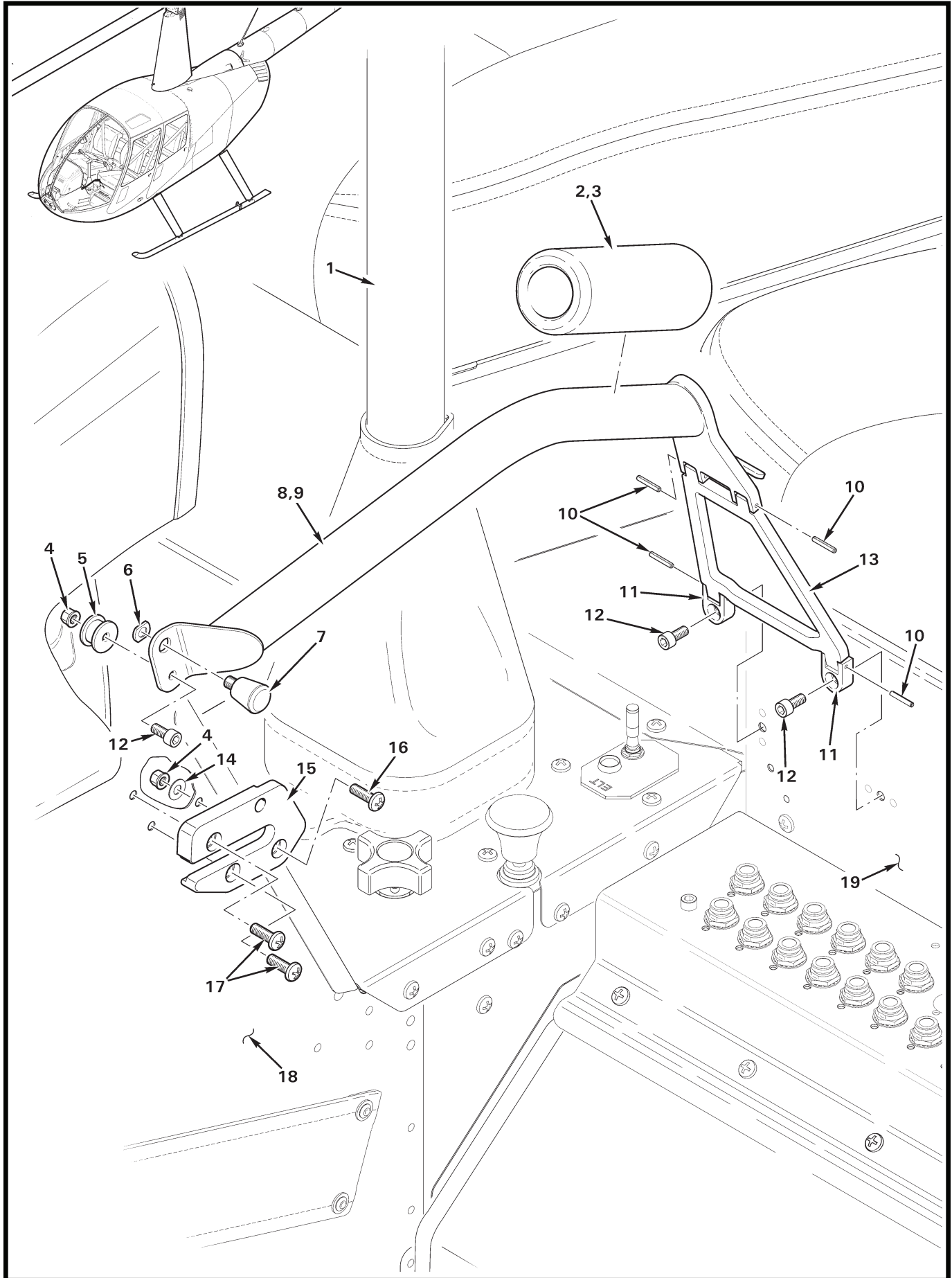

FIGURE AND INDEX NUMBER	PART NUMBER	DESCRIPTION	PARTS AVAIL	QTY PER ASSY
GUARD ASSEMBLY INSTALLATION				
25-49-1	C069	Cyclic Control Assembly (Ref)		
2	A601-2	Grip (install using item 3)	X	1
3	B270-15	Adhesive	X	A/R
4	MS21042L08	Nut	X	2
5	G722-7	Latch	X	1
6	—	Washer (threaded)	O	1
7	56-99-196-20	Plunger (Incl item 6)	X	1
8	G721-1	Handle Assembly (Incl items 2 thru 5, 7, and 9 thru 13).	X	1
9	G721-2	Weldment	X	1
10	MS16562-15	Spring Pin	X	4
11	G722-5	Mount	X	2
12	NAS1352-08-6	Screw	X	3
13	G722-4	Support – Lower	X	1
14	NAS1149FN816P	Washer	X	1
15	G722-6	Plate	X	1
16	MS27039C0807	Screw	X	1
17	MS27039C0808	Screw	X	2
18	C033	Console Assembly – Lower (Ref)		
19	C297-5	Support Assembly (LH, forward; Ref)		

NOTES * Optional equipment. Refer to KI-280 for field installation.

Intentionally Blank

CHAPTER 28**FUEL SYSTEM**

<i>Figure</i>	<i>Title</i>	<i>Page</i>
28-1	Fuel System Installation	28.0
28-5	Fuel System Installation	28.4
28-9	Main Tank Assembly	28.8
28-11	Main Tank Assembly	28.10
28-13	Auxiliary Tank Assembly	28.12
28-17	Fuel Shut-Off Valve Installation	28.16
28-19	Gascolator Assembly	28.18
28-21	Electric Fuel Pump Installation	28.20
28-25	Electric Fuel Pump Installation	28.24
28-29	Fuel Control (Servo) Installation	28.28
28-33	Return Hose Installation	28.32
28-35	Intake Manifold Drain Installation	28.34
28-37	Primer System	28.36
28-41	Primer Pump Installation	28.40

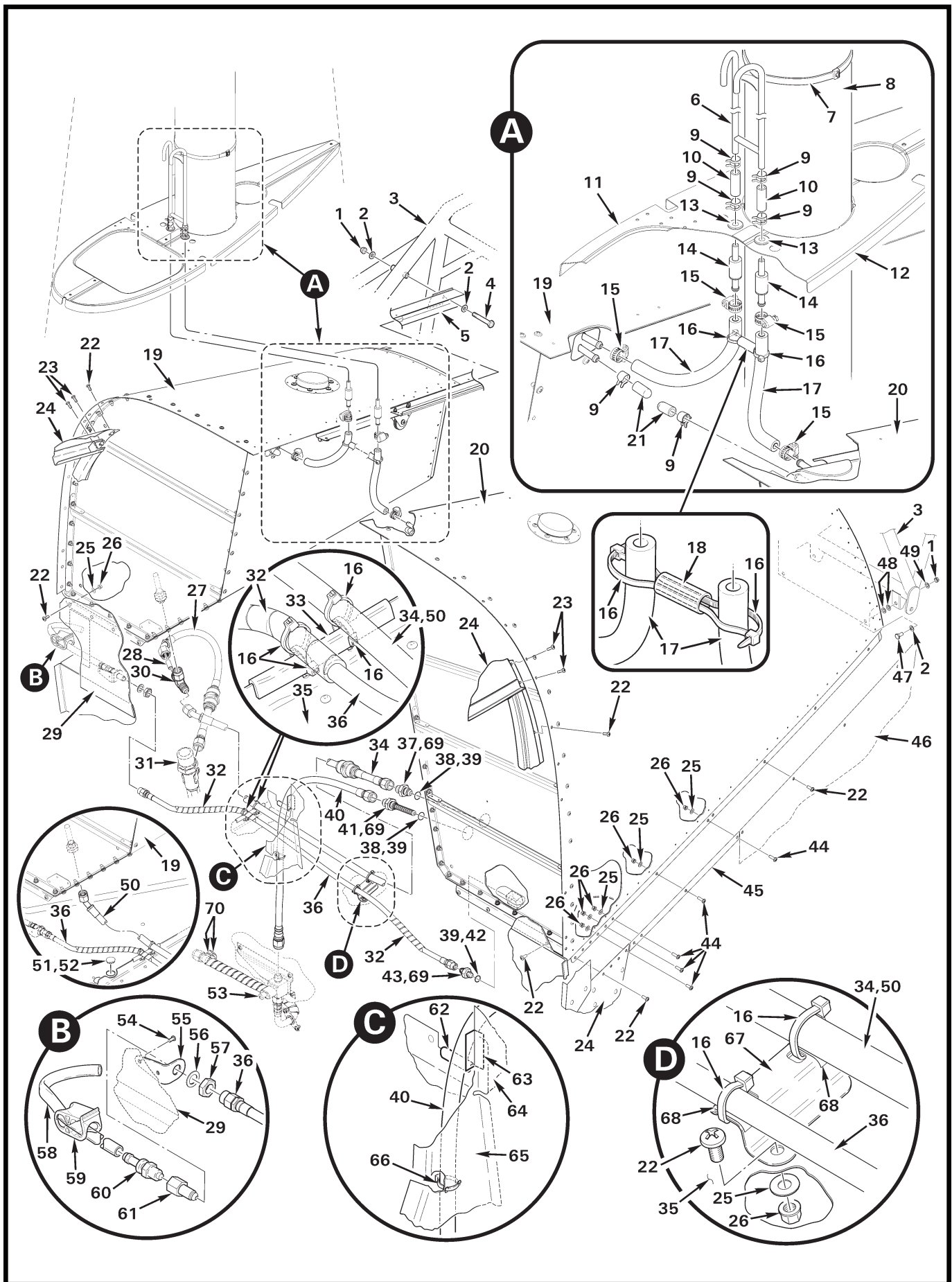

FIGURE AND INDEX NUMBER	PART NUMBER	DESCRIPTION	PARTS AVAIL	QTY PER ASSY
FUEL SYSTEM INSTALLATION				
28-1-1	D210-4	Nut	X	3
2	NAS1149F0432P	Washer	X	3
3	C020-1	Upper Frame Assembly (Ref)		
4	NAS6604-22	Bolt	X	1
5	C245-1	Channel (Ref)		
6	A731-10	Tube Assembly	X	1
7	MS3367-6-0	Ty-Rap	X	1
8	C006	Main Rotor Gearbox Assembly (Ref)		
9	D277-6	Clamp	X	A/R
10	A729-79	Tube	X	2
11	C261-14*	Rib Assembly – Lower (RH, small mast; Ref)		
	C261-20*	Rib Assembly – Lower (RH, large mast; Ref, not shown)		
12	C261-13*	Rib Assembly – Lower (LH, small mast; Ref)		
	C261-19*	Rib Assembly – Lower (LH, large mast; Ref, not shown)		
13	MS35489-6	Grommet (Ref)		
14	D251-1	Valve Assembly – Rollover (Vent)	X	2
15	B277-4	Clamp	X	6
16	MS3367-4-9	Ty-Rap	X	8
17	A729-48	Tube	X	2
18	A729-63	Tube	X	1
19	D043-5	Auxiliary Tank Assembly (Ref, see Figure 28-13)		
20	C010-6	Main Fuel Tank Assembly (Ref, see Figure 28-9)		
21	A457-19	Cap (earlier R44s, if lower vent is present)	X	2
22	MS27039C0806	Screw	X	23
23	MS27039C0808	Screw	X	4
24	C015	Cabin Assembly (Ref)		
25	NAS1149FN816P	Washer	X	10
26	MS21042L08	Nut	X	10
27	C595-4	Hose Assembly (IO-540 ships)	X	1
28	D453-5	Jet (IO-540 ships)	X	1
29	C259-2	Panel - Bulkhead (RH, Ref)		
30	D453-4	Tee (IO-540 ships)	X	1
31	D321-1	Valve Assembly (IO-540 ships, see Figure 28-33; Ref)		
32	B161-4	Spirap	X	A/R
33	A226-11	Trim	X	A/R

NOTES * See Figure 53-11 for mast fairing assembly.

Continues

FIGURE AND INDEX NUMBER	PART NUMBER	DESCRIPTION	PARTS AVAIL	QTY PER ASSY
FUEL SYSTEM INSTALLATION (Cont'd)				
28-1-34	C595-3	Hose Assembly (IO-540 ships)	X	1
35	C234-1	Firewall (Ref, LH fwd horizontal)		
36	D205-30	Hose Assembly	X	1
37	A880-936*	Union (or A880-966)	X	1
38	MS29512-06	Packing (install using item 39)	X	2
39	A257-6	Grease	X	A/R
40	D205-38	Hose Assembly	X	1
41	B254-3	Strainer Assembly – Fuel	X	1
42	MS29512-03	Packing (install using item 39)	X	1
43	A880-933*	Union (or A880-963)	X	1
44	MS27039C0807	Screw	X	4
45	C380-7	Strip (Ref; LH)		
	C364-6	Strip (Ref; RH, not shown)		
46	C377-1	Cowling Assembly (Ref, LH)		
47	NAS6604-2	Bolt	X	2
48	NAS1149F0432P	Washer (or NAS1149D0416J; as required to fill gap between tank assembly and frame)	X	A/R
49	NAS1149F0463P	Washer (or NAS1149F0432P)	X	2
50	C595-2	Hose Assembly (O-540 ships)	X	1
51	B209-7	Plug (O-540 ships; install using item 52)	X	1
52	B270-1	Sealant	X	A/R
53	C670-1	Shut-Off Valve – Fuel (Ref)		
54	MS20470AD3	Rivet	X	2
55	D255-2	Angle	X	1
56	NAS1149F0632P	Washer	X	1
57	A880-1003	Nut	X	1
58	A729-17	Tube	X	1
59	D663-1	Clamp	X	1
60	A761-1	Drain Valve	X	1
61	D255-1	Connector	X	1
62	A226-15	Trim	X	A/R
63	A701-1	Tape – Aluminum	X	A/R
64	C259-1	Panel - Bulkhead (LH, Ref)		
65	C351-1	Brace (Ref)		
66	MS3367-5-9	Ty-Rap	X	1

NOTES * Apply item 69 to threads.

Continues

FIGURE AND INDEX NUMBER	PART NUMBER	DESCRIPTION	PARTS AVAIL	QTY PER ASSY
FUEL SYSTEM INSTALLATION (Cont'd)				
28-1-67	D255-5	Support Assembly	X	1
68	A701-3	Tape – Urethane (0.3125" wide)	X	1
69	A457-9	Anti-seize	X	A/R
70	B161-8	Spirap (IO-540 ships)	X	A/R
NOTES				

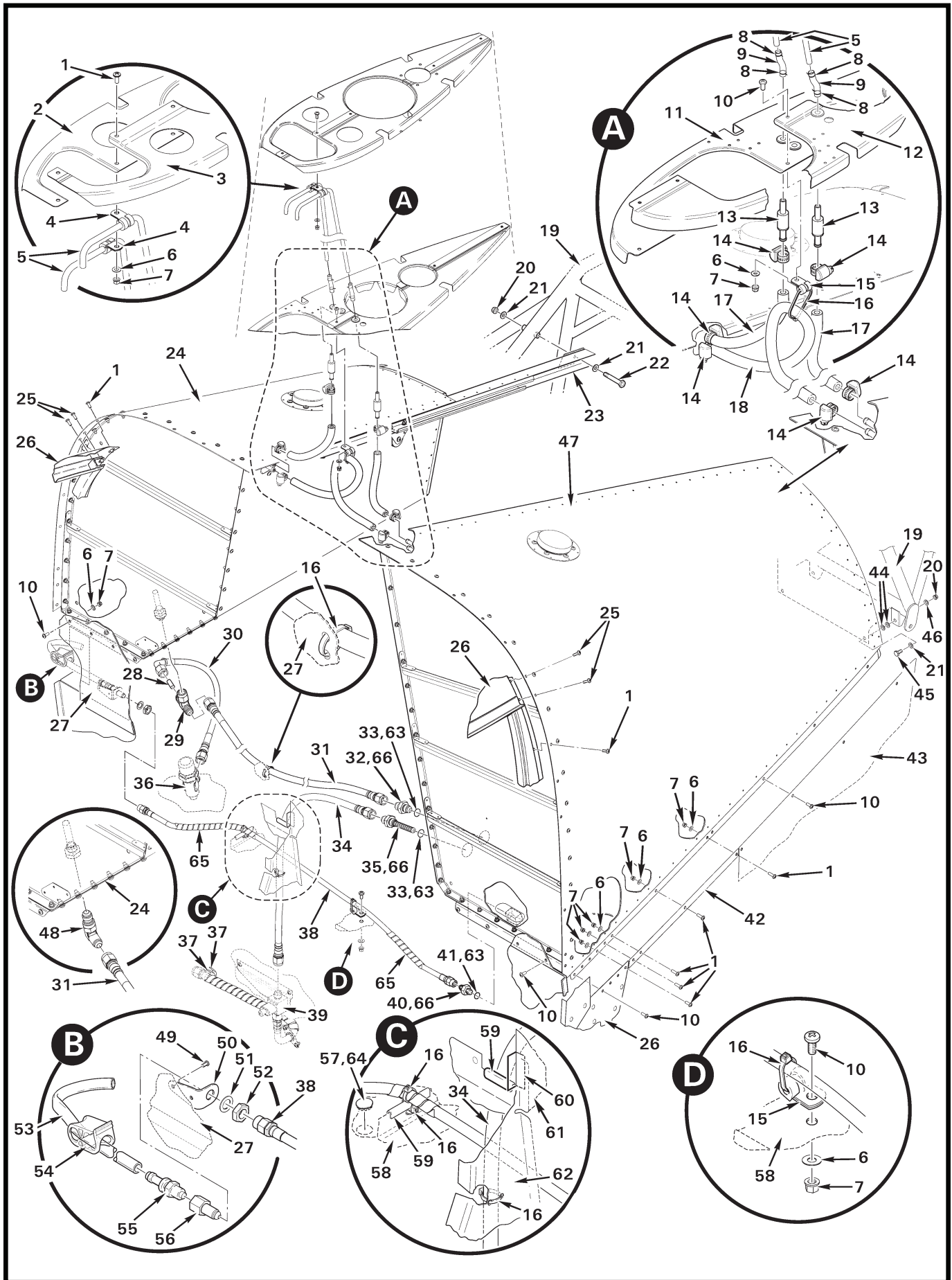

FIGURE AND INDEX NUMBER	PART NUMBER	DESCRIPTION	PARTS AVAIL	QTY PER ASSY
FUEL SYSTEM INSTALLATION				
28-5-1	MS27039C0807	Screw	X	35
2	C261-18*	Rib Assembly – Middle (RH, Ref)		
3	C261-17*	Rib Assembly – Middle (LH, Ref)		
4	MS21919WDG4	Clamp	X	2
5	C731-2	Line – Vent (earlier R44s)	X	2
6	NAS1149FN816P	Washer	X	15
7	MS21042L08	Nut	X	15
8	MS20995C32	0.032-in. dia. Safety Wire	X	A/R
9	A729-47	Tube (earlier R44s).	X	2
10	MS27039C0806	Screw	X	15
11	C261-14*	Rib Assembly – Lower (RH, small mast; Ref)		
	C261-20*	Rib Assembly – Lower (RH, large mast; Ref, not shown)		
12	C261-13*	Rib Assembly – Lower (LH, small mast; Ref)		
	C261-19*	Rib Assembly – Lower (LH, large mast; Ref, not shown)		
13	D251-1	Valve Assembly – Rollover (Vent)	X	2
14	B277-4	Clamp	X	6
15	MS21919WDG3	Clamp	X	2
16	MS3367-5-9	Ty-Rap	X	A/R
17	A729-48	Tube	X	2
18	A729-49	Tube (earlier R44s).	X	1
19	C020-1	Upper Frame Assembly (Ref)		
20	D210-4	Nut	X	3
21	NAS1149F0432P	Washer	X	4
22	NAS6604-22	Bolt	X	1
23	C245-1	Channel (Ref)		
24	D043-5	Auxiliary Tank Assembly (Ref, see Figure 28-9)		
25	MS27039C0808	Screw	X	4
26	C015	Cabin Assembly (Ref)		
27	C259-2	Panel - Bulkhead (RH, Ref)		
28	D453-2	Jet (IO-540 ships; earlier R44s)	X	1
29	D453-3	Tee (IO-540 ships; earlier R44s)	X	1
30	D205-31	Hose Assembly IO-540 ships; earlier R44s)	X	1
31	D205-29	Hose Assembly (earlier R44s)	X	1
32	A880-936**	Union (or A880-966)	X	1
33	MS29512-06	Packing (install using item 63)	X	1

NOTES * See Figure 53-11 for mast fairing assembly.
 ** Apply item 66 to threads.

Continues

FIGURE AND INDEX NUMBER	PART NUMBER	DESCRIPTION	PARTS AVAIL	QTY PER ASSY
FUEL SYSTEM INSTALLATION (Cont'd)				
28-5-34	D205-28	Hose Assembly	X	1
35	B254-3	Strainer Assembly – Fuel (Ref)		
36	D321-1	Valve Assembly (IO-540 ships, see Figure 28-33; Ref)		
37	B161-8	Spirap (IO-540 ships)	X	A/R
38	D205-30	Hose Assembly	X	1
39	C670-1	Shut-Off Valve – Fuel (Ref)		
40	A880-933*	Union (or A880-963)	X	1
41	MS29512-03	Packing (lubricate using item 63)	X	1
42	C380-7	Strip (Ref; LH)		
	C364-6	Strip (Ref; RH, not shown)		
43	C377-1	Cowling Assembly (Ref, LH)		
44	NAS1149F0432P	Washer (or NAS1149D0416J as required to fill gap between tank assembly and frame)	X	A/R
45	NAS6604-2	Bolt	X	2
46	NAS1149F0463P	Washer (or NAS1149F0432P)	X	2
47	C010-6	Main Fuel Tank Assembly (Ref, see Figure 28-9)		
48	A457-12	Elbow (O-540 ships)	X	1
49	MS20470AD3	Rivet	X	2
50	D255-2	Angle	X	1
51	NAS1149F0632P	Washer	X	1
52	A880-1003	Nut	X	1
53	A729-17	Tube	X	1
54	D663-1	Clamp	X	1
55	A761-1	Drain Valve	X	1
56	D255-1	Connector	X	1
57	B209-7	Plug (O-540 ships; seal using item 64)	X	1
58	C234-1	Firewall – Horizontal (Ref)		
59	A226-11	Trim	X	A/R
60	A701-1	Tape – Aluminum	X	A/R
61	C259-1	Panel - Bulkhead (LH, Ref)		
62	C351-1	Brace (Ref)		
63	A257-6	Grease	X	A/R
64	B270-1	Sealant	X	A/R
65	B161-4	Spirap	X	A/R
66	A457-9	Anti-seize	X	A/R

NOTES * Apply item 66 to threads.

Intentionally Blank

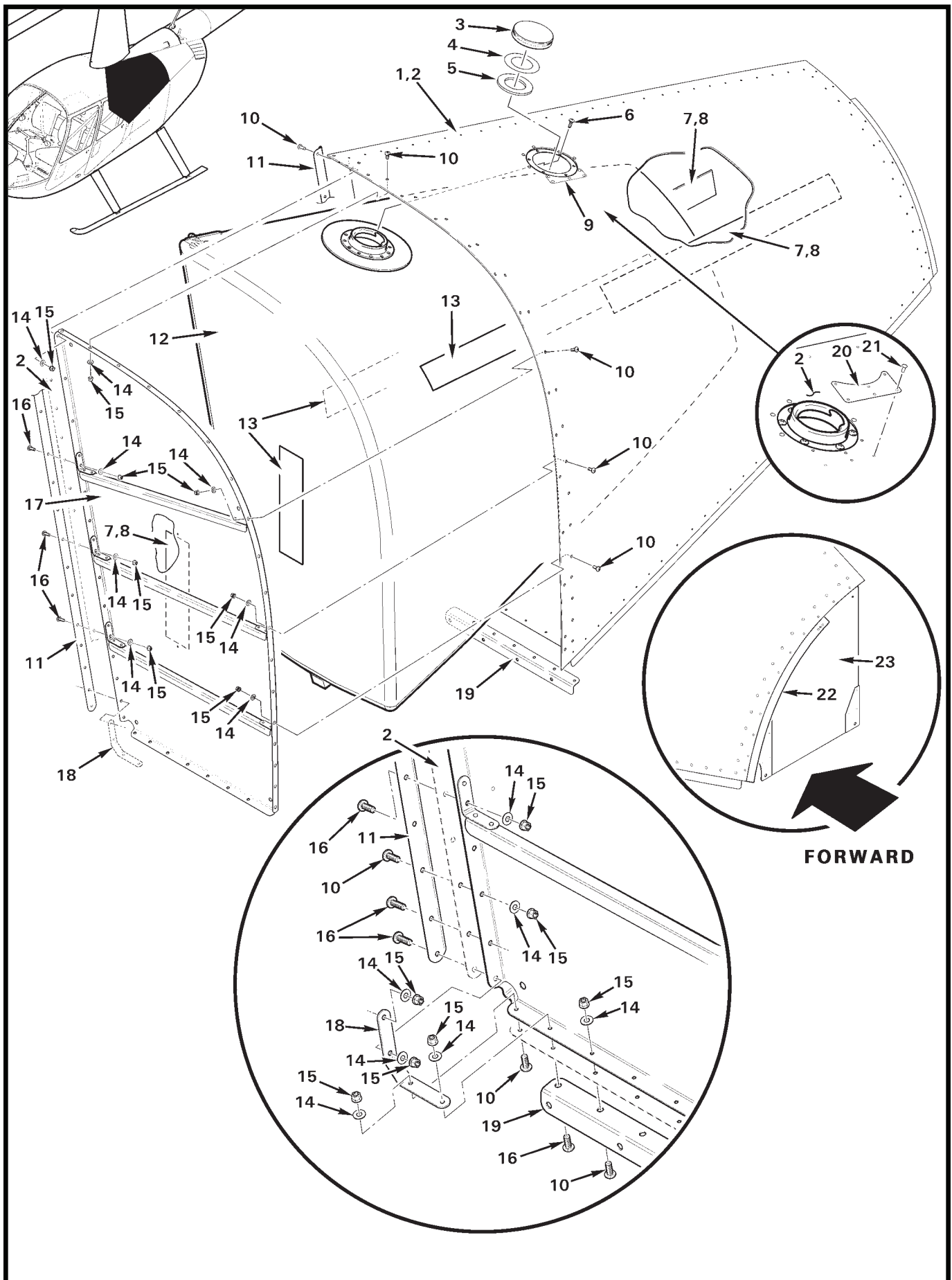

FIGURE AND INDEX NUMBER	PART NUMBER	DESCRIPTION	PARTS AVAIL	QTY PER ASSY
MAIN TANK ASSEMBLY				
28-9-1	C010-6	Main Tank Assembly (Includes items 2, 3, 6, 12, and 14 thru 16. Also items 2 thru 5, 8 thru 10, 12 thru 16, 18, 19, 21, 23, 25, 26, 28, and 29 from Figure 28-7.)	X	1
2	D029-1	Tank Assembly (Aluminum enclosure; includes item 7 thru 9, 11, 14 thru 19, 22, and 23.)	X	1
3	A689-6*	Cap Assembly (Incl items 4 and 5; unpainted)	X	1
	R7295**	Cap Assembly (Incl items 4 and 5; painted white)	X	1
	R7998**	Cap Assembly (Incl items 4 and 5; primer only)	X	1
4	A689-8	Washer (plastic)	X	1
5	A689-7	Gasket (rubber)	X	1
6	A142-1	Screw	X	6
7	B175-4	Loop Tape (install using item 8)	X	A/R
8	B270-8qt	Adhesive	X	A/R
9	D249-13	Doubler	X	1
10	MS27039C0806	Screw	X	34
11	D248-9	Angle	X	1
12	D028-1	Bladder Assembly (Incl item 13)	X	1
13	B175-3	Hook Tape (three places; Ref)		
14	NAS1149FN816P	Washer	X	39
15	MS21042L08	Nut	X	39
16	MS27039C0807	Screw	X	5
17	D247-1	Bulkhead Assembly	X	1
18	D249-6	Angle	X	1
19	D248-8	Angle	X	1
20	D827-1	Doubler (repair; for fuel tanks <u>without</u> item 9 installed)	X	1
21	MS20470AD3	Rivet	X	6
22	C028-10	Strip (Ref)		
23	C028-7	Web (Ref)		

NOTES * If replacing cap assembly, order D682-44 decal and refer to R44 Service Bulletin SB-84.
 ** Includes D682-44 decal.

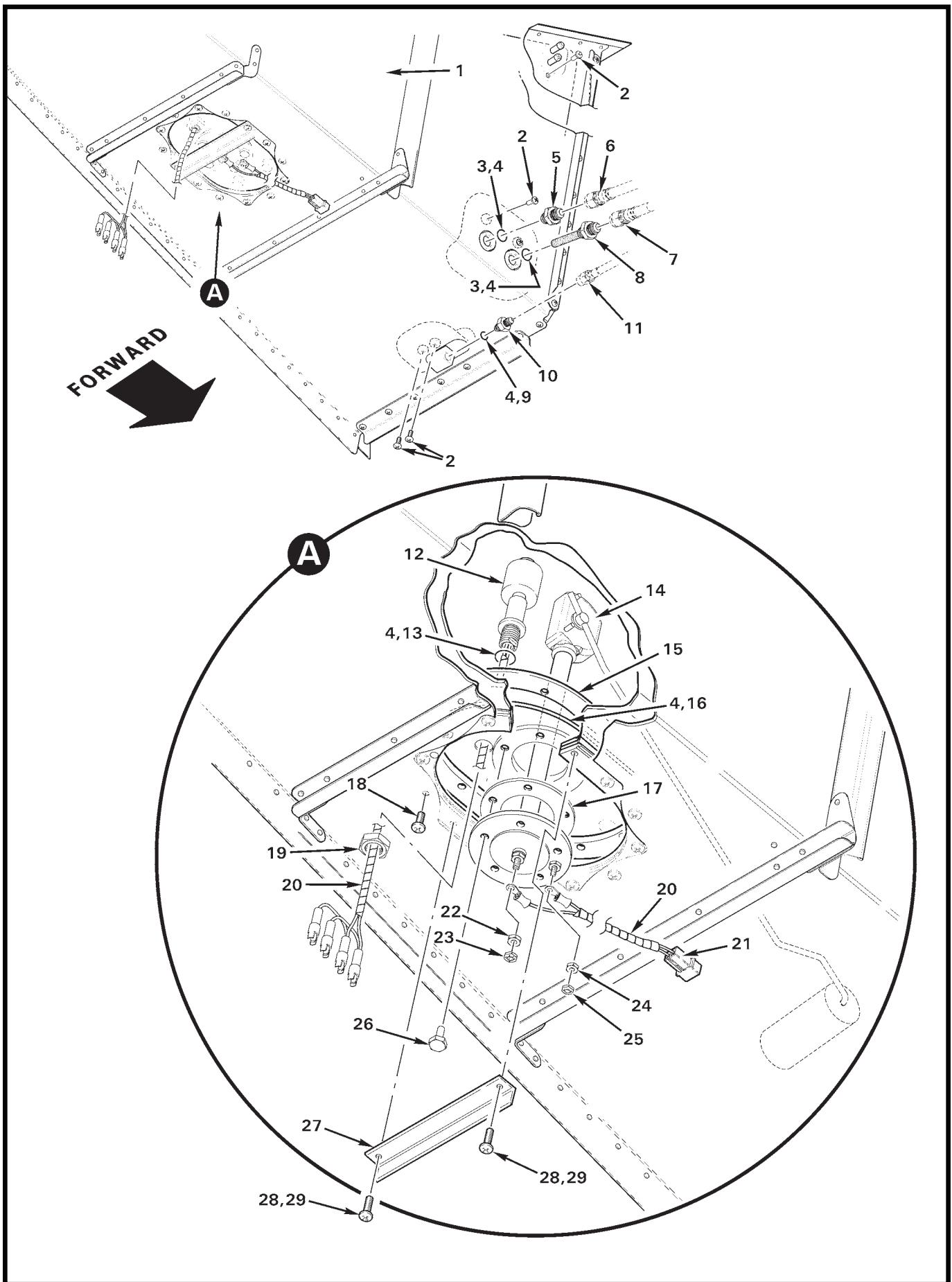

FIGURE AND INDEX NUMBER	PART NUMBER	DESCRIPTION	PARTS AVAIL	QTY PER ASSY
MAIN TANK ASSEMBLY				
28-11-1	C010-6	Main Tank Assembly (Ref; includes items 2 thru 5, 8 thru 10, 12 thru 16, 18, 19, 21, 23, 25 thru 29; also items 2, 3, 6, and 11 from Figure 28-9.)		
2	MS29039C1-06	Screw	X	5
3	MS29512-06	Packing (install using item 4)	X	2
4	A257-6	Grease	X	A/R
5	AN815-6D	Union	X	1
6	D205-29	Hose Assembly (Ref)		
7	D205-28	Hose Assembly (Ref)		
8	B254-3	Strainer Assembly	X	1
9	MS29512-03	Packing (install using item 4)	X	1
10	AN815-3D	Union	X	1
11	D205-30	Hose Assembly (Ref)		
12	A521-1	Switch Assembly – Low Fuel (Includes item 20, wires, housings, and pins; assembled as shown.)	X	1
13	MS29512-05	Packing (install using item 4)	X	1
14	D252-1	Sender – Fuel Quantity (Incl items 17, 22, and 24)	X	1
15	D250-1	Cover Assembly	X	1
16	MS29513-260	Packing (install using item 4)	X	1
17	15-423	Gasket	X	1
18	MS27039C1-08	Screw (install using item 29)	X	12
19	AN924-5D	Nut	X	1
20	B161-2	Spirap	X	A/R
21	C049-11	Wire Harness Assembly (Includes item 20, wires, housing, and pins; assembled as shown.)	X	1
22	0044-00408	Nut (large; Ref)		
23	B330-6	Palnut	X	1
24	44-121	Nut (small; Ref)		
25	B330-5	Palnut	X	1
26	B289-1	Bolt	X	5
27	A374-5	Angle	X	1
28	MS27039C1-09	Screw (install using item 29)	X	2
29	A257-9	Anti-seize	X	A/R

NOTES

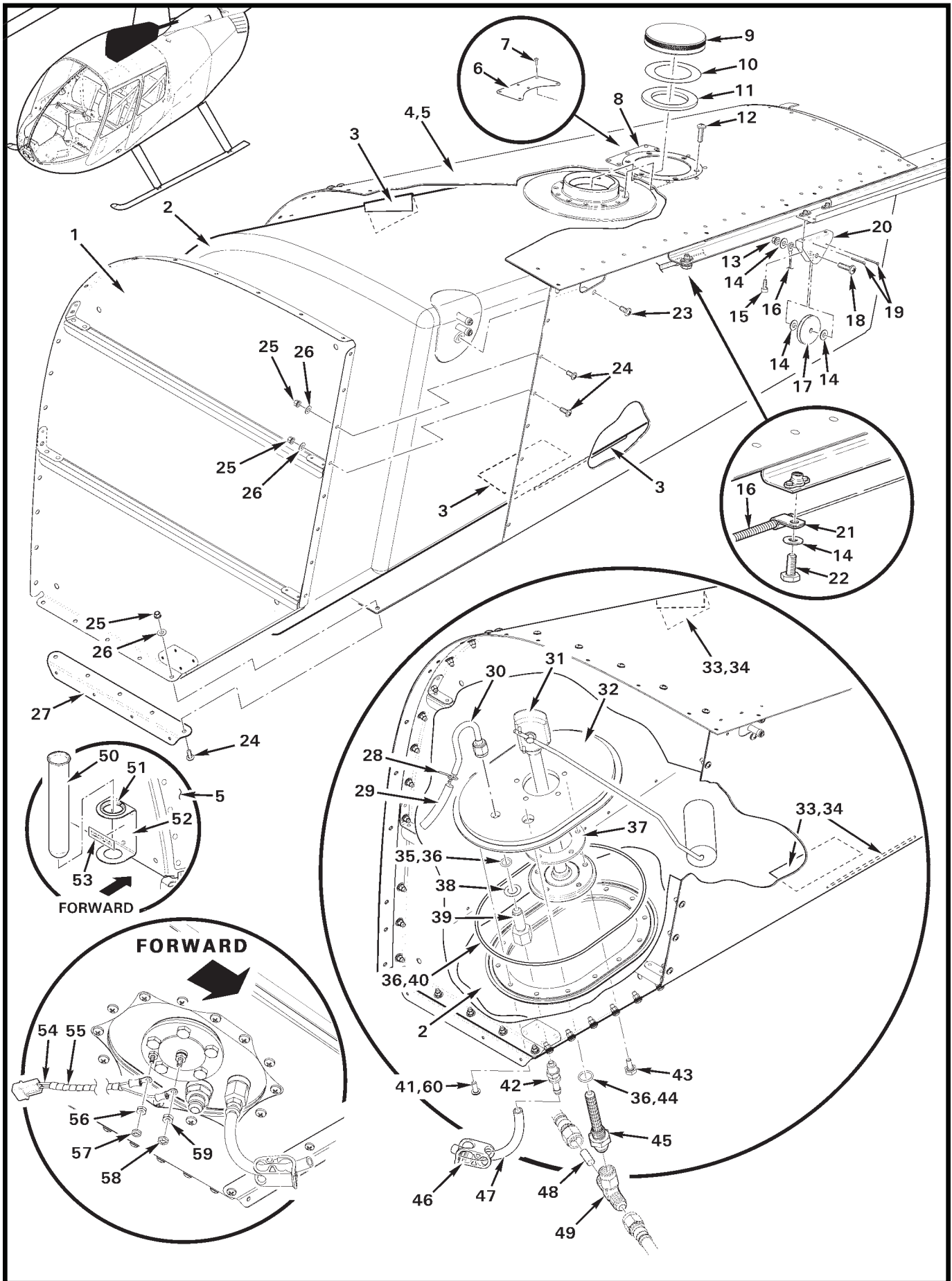

FIGURE AND INDEX NUMBER	PART NUMBER	DESCRIPTION	PARTS AVAIL	QTY PER ASSY
AUXILIARY TANK ASSEMBLY				
28-13-1	D247-2	Bulkhead Assembly	X	1
2	D028-2	Bladder Assembly (Incl item 3)	X	1
3	B175-3	Hook Tape (three places; Ref)		
4	D043-5	Aux Fuel Tank Assembly (Incl items 2, 5, 9, 12 thru 15, 17 thru 21, 23, 28 thru 32, 35, 36, 38 thru 47, 54, 57, 58, and 60)	X	1
5	D045-1	Tank Assembly (aluminum enclosure; includes items 1, 7, 8, 24 thru 27, 33, 34, and 52)	X	1
6	D827-1	Doubler (for fuel tanks <u>without</u> item 8 installed)	X	1
7	MS20470AD3	Rivet	X	6
8	D249-13	Doubler	X	1
9	A689-6*	Cap Assembly (Incl item 10 and 11)	X	1
	R7295**	Cap Assembly (Incl items 10 and 11; painted white)	X	1
	R7998**	Cap Assembly (Incl items 10 and 11; primer only)	X	1
10	A689-8	Washer (plastic)	X	1
11	A689-7	Gasket (rubber)	X	1
12	A142-1	Screw	X	6
13	MS21042L3	Nut	X	1
14	NAS1149F0332P	Washer	X	4
15	NAS1352N06-6	Screw	X	2
16	D126-1	Cable Assembly (Ref)		
17	MS24566-1B	Pulley (alternate part no. AN210-1A)	X	1
18	MS27039C1-11	Screw	X	1
19	MS24665-134	Cotter Pin	X	2
20	B157-1	Mount	X	1
21	AN742-3	Clamp	X	1
22	NAS6603-2	Bolt	X	1
23	MS27039C1-06	Screw	X	1
24	MS27039C0806	Screw	X	36
25	MS21042L08	Nut	X	36
26	NAS1149FN816P	Washer	X	36
27	D253-3	Angle	X	1
28	D277-6	Clamp	X	1
29	A729-50	Tube	X	1
30	D255-3	Siphon Assembly	X	1

NOTES * If replacing cap assembly, order D682-44 decal and refer to R44 Service Bulletin SB-84.
 ** Includes D682-44 decal.

Continues

FIGURE AND INDEX NUMBER	PART NUMBER	DESCRIPTION	PARTS AVAIL	QTY PER ASSY
AUXILIARY TANK ASSEMBLY (Cont'd)				
28-13-31	D252-2	Sender – Fuel Quantity (Incl items 37, 56, and 59)	X	1
32	D250-2	Cover Assembly	X	1
33	B270-8qt	Adhesive	X	A/R
34	B175-4	Loop Tape (install using item 33)	X	A/R
35	MS29512-04	Packing (install using item 36)	X	1
36	A257-6	Grease	X	A/R
37	15-423	Gasket	X	1
38	NAS1149F0732P	Washer	X	1
39	D255-4	Connector	X	1
40	MS29513-260	Packing (install using item 36)	X	1
41	MS27039C1-08	Screw (install using item 60)	X	14
42	A761-1	Drain Valve Assembly	X	1
43	B289-1	Bolt	X	5
44	MS29512-06	Packing (install using item 36)	X	1
45	B254-3	Strainer Assembly	X	1
46	D663-1	Clamp	X	1
47	A729-43	Tube	X	1
48	D453-5	Jet (Ref, see Figure 28-1)		
49	D453-4	Tee (Ref, see Figure 28-1)		
50	MT106-3	Tube – Fuel Sample (glass)	X	1
51	NAS557-16A	Grommet	X	1
52	G926-7	Holder (Ref)	O	1
53	G682-21	Decal – “STOW MT106-3 FUEL SAMPLE TUBE HERE”	X	1
54	C049-11	Wire Harness Assembly (Includes item 55, wires, housing pins, assembled as shown.)	X	1
55	B161-2	Spirap	X	A/R
56	44-121	Nut (small; Ref)		
57	B330-5	Palnut	X	1
58	B330-6	Palnut	X	1
59	0044-00408	Nut (large; Ref)		
60	A257-9	Anti-Seize	X	A/R

NOTES

Intentionally Blank

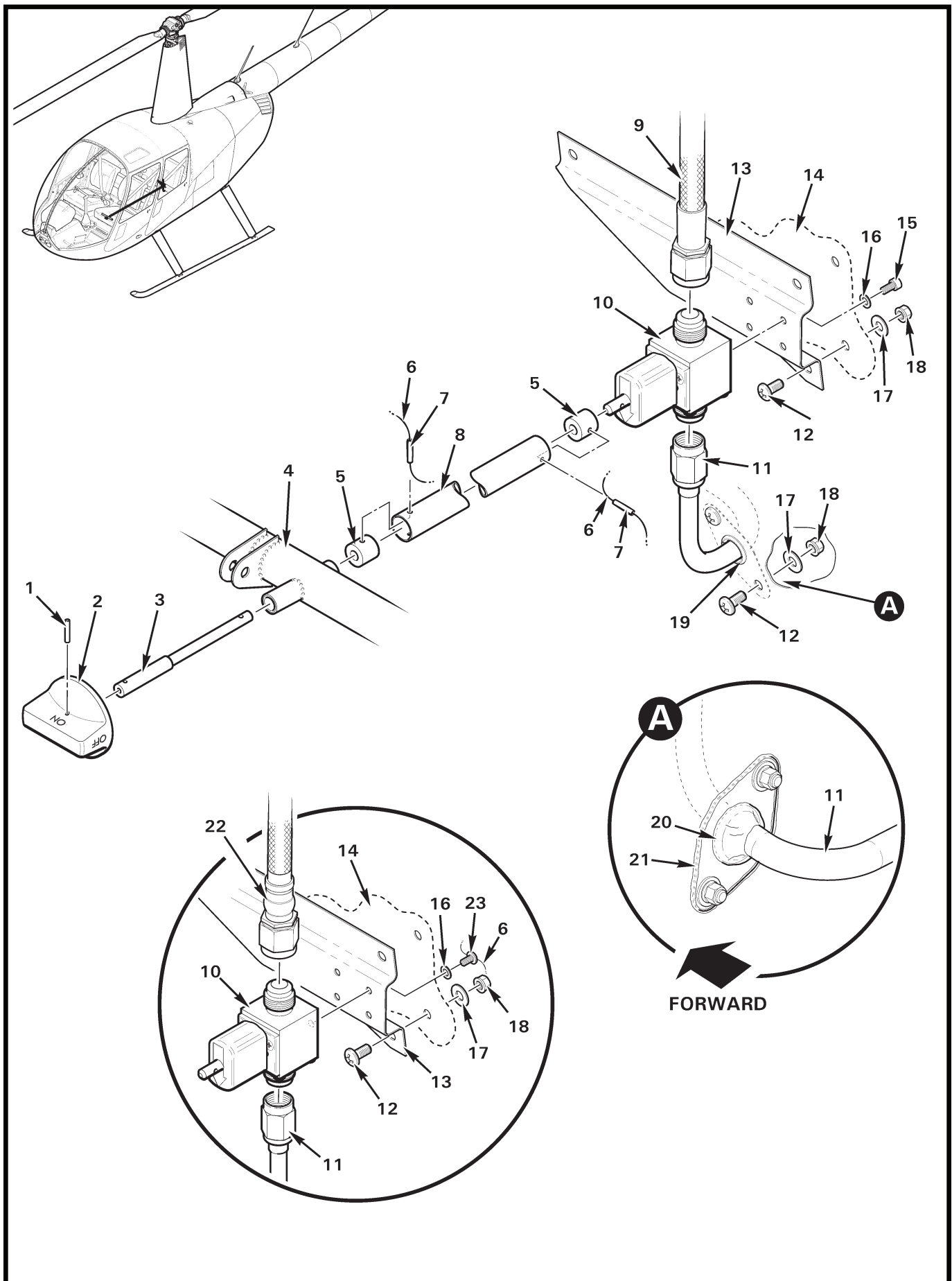

FIGURE AND INDEX NUMBER	PART NUMBER	DESCRIPTION	PARTS AVAIL	QTY PER ASSY
FUEL SHUT-OFF VALVE INSTALLATION				
28-17-1	MS16562-5	Spring Pin	X	1
2	C499-1	Knob	X	1
3	C791-3	Shaft	X	1
4	C348-1	Anchor Assembly (collective stop)	X	1
5	C791-4	Spacer	X	2
6	MS20995C32	0.032-in. dia. Safety Wire	X	A/R
7	MS16562-16	Spring Pin	X	2
8	C791-2	Tube	X	1
9	D205-38	Hose Assembly	X	1
10	C670-1	Fuel Valve	X	1
11	C741-1	Fuel Line Assembly	X	1
12	MS27039C0805	Screw	X	3
13	C798-3	Bracket (supersedes C798-2)	X	1
14	C233-1	Vertical Firewall (Ref)		
15	NAS1352-04LB3P	Screw (or NAS1352-04LE3P)	X	4
16	NAS620-4	Washer	X	4
17	NAS1149FN832P	Washer	X	4
18	MS21042L08	Nut	X	4
19	NAS557-8A	Grommet	X	1
20	B270-5	Sealant (7.5-oz. tube)	X	A/R
21	B270-1	Sealant (2-part)	X	A/R
22	D205-28	Hose Assembly (earlier R44s)	X	1
23	AN500A4-3	Screw (earlier R44s)	X	4

NOTES

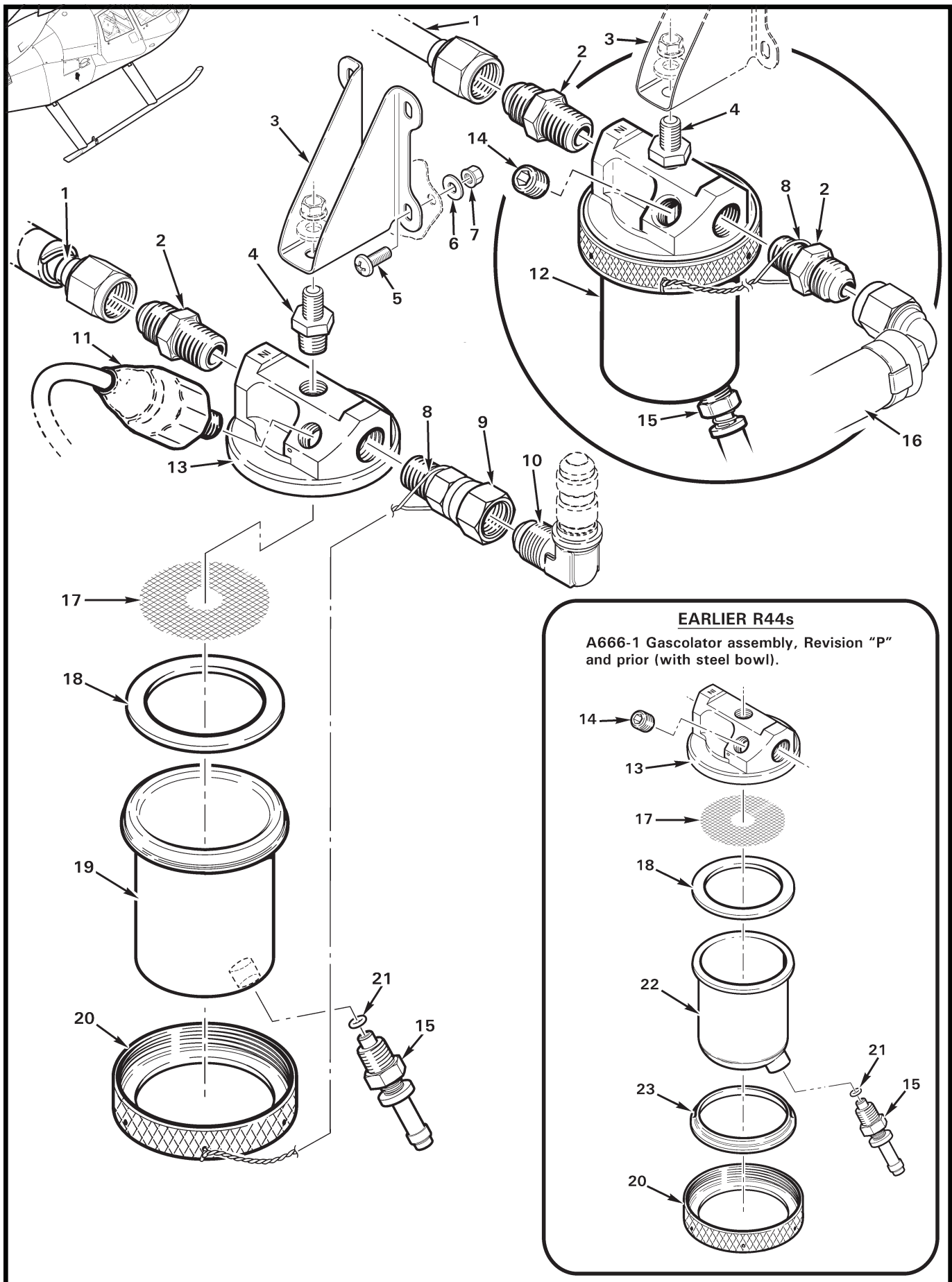

FIGURE AND INDEX NUMBER	PART NUMBER	DESCRIPTION	PARTS AVAIL	QTY PER ASSY
GASCOLATOR ASSEMBLY				
28-19-1	C741-1	Line Assembly (Ref)		
2	A880-536	Adapter*** (or A880-566)	X	A/R
3	A454-1	Support	X	1
4	A455-1	Plug***	X	1
5	MS27039C0806	Screw	X	4
6	NAS1149FN832P	Washer	X	4
7	MS21042L08	Nut	X	4
8	MS20995C32	0.032-in. dia. Safety Wire	X	A/R
9	A457-11*	Adapter (Ref; IO-540 ships)		
	6505-04-06-SS*	Adapter (Ref, see also Figures 28-21 and 28-25; IO-540 ships)		
10	A880-836*	Elbow (or A880-866; Ref, IO-540 ships)		
11	D745-1	Switch Assembly (Ref; IO-540 ships)		
12	A666-1	Gascolator Assembly (Revision "Q" and subsequent. Includes items 4, 13, 15, 17 thru 20, and 24.)	X	1
13	B402-3	Top	O	1
14	MS27769D2*	Plug (O-540 ships)	X	1
15	A761-1*	Drain Valve – Gascolator (Incl item 21)	X	1
	CAV-110H-4**	Drain Valve – Gascolator	O	1
16	B283-3	Hose Assembly (Ref, see also Figures 28-21 and 28-25)		
17	10543-2	Screen	X	1
18	10536-1	Gasket (supersedes 10536)	X	1
19	B416-3	Bowl (aluminum)	X	1
20	B416-1	Collar	O	1
21	A215-006	O-Ring	X	1
22	10541	Bowl (steel)	X	1
23	B416-2	Ring (Ref)		
24	B270-6	Sealant	X	A/R

NOTES * Install using item 24.
 ** Saf-Air part no., installed in A666-1 gascolator assembly. Order A761-1 when replacing valve.

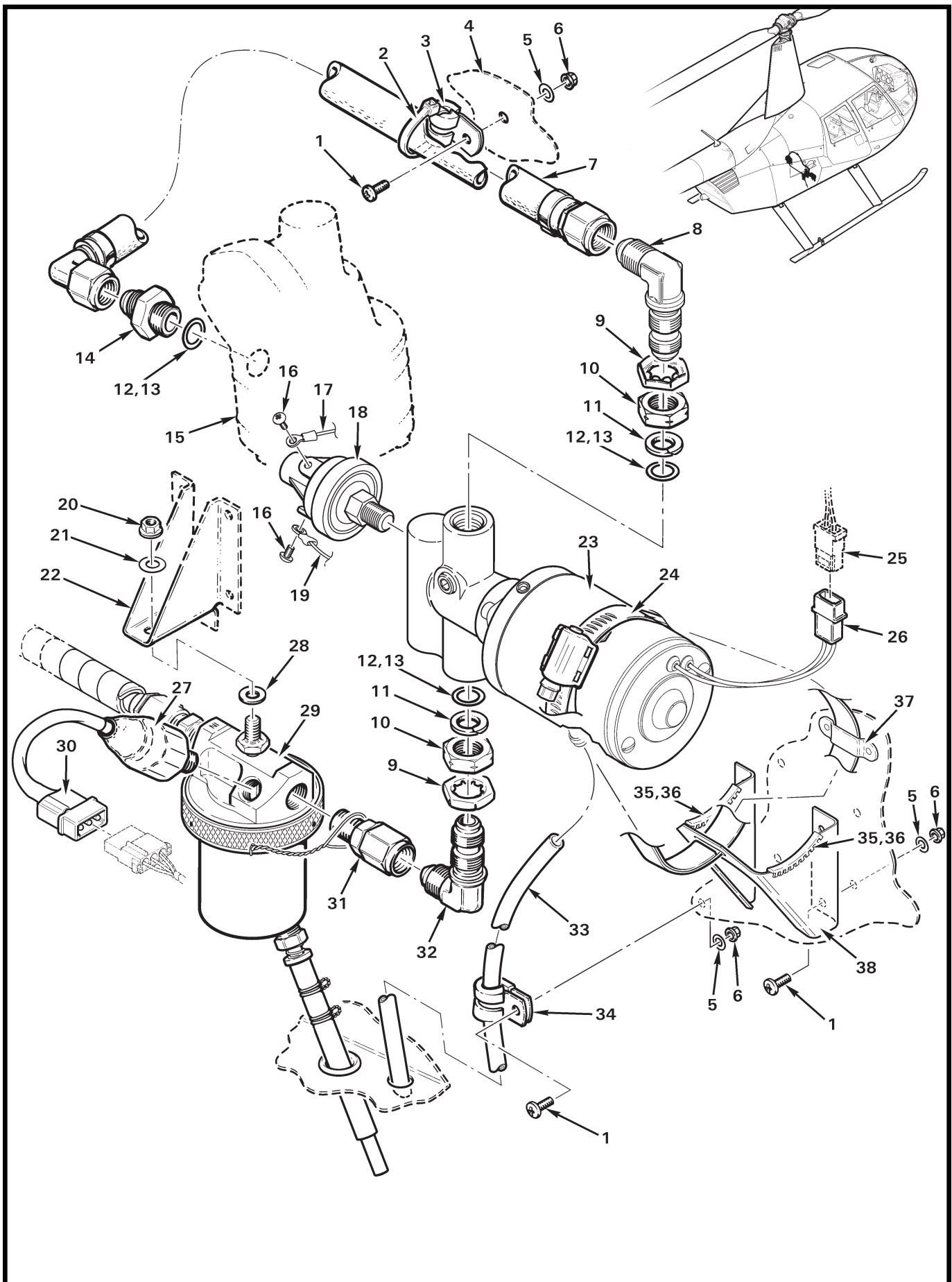

FIGURE AND INDEX NUMBER	PART NUMBER	DESCRIPTION	PARTS AVAIL	QTY PER ASSY
ELECTRIC FUEL PUMP INSTALLATION*				
28-21-1	MS27039C0806	Screw	X	6
2	MS3367-5-9	Ty-Rap	X	1
3	MS21919WDG3	Clamp	X	1
4	C233-1	Firewall – Vertical (Ref)		
5	NAS1149FN816P	Washer	X	6
6	MS21042L08	Nut	X	6
7	B283-3	Hose Assembly	X	1
8	AN833-6D	Elbow (aluminum, blue)	X	1
9	B330-25	Palnut	X	2
10	D452-6	Nut	X	2
11	D454-6	Retainer	X	2
12	MS29512-06	Packing (o-ring; lubricate with item 13)	X	3
13	A257-6	Grease	X	A/R
14	MS21900D6	Adapter	X	1
15	—	Fuel Pump (engine-driven; Ref)		
16	—	Screw	O	2
17	C859-1530	Wire (Ref)		
18	B426-2	Pressure Switch (Incl Item 16)	X	1
19	C859-1542	Wire (Ref)		
20	MS21042L4	Nut (Ref)		
21	NAS1149F0463P	Washer (Ref)		
22	A454-1	Support (Ref)		
23	D743-3	Pump Assembly (Incl item 26)	X	1
24	HTM-300	Clamp	X	1
25	B263-13	Housing (Ref)		
26	B263-12	Housing	X	1
	B263-1	Pin	X	2
27	D745-1	Switch Assembly – Vacuum (Incl item 30)	X	1
28	NAS1149F0432P	Washer	X	A/R
29	A666-1	Gascolator (Ref; see Figure 28-15)		
30	B263-14	Housing	X	1
	B263-1	Pin (pins 1 and 3)	X	2
	B263-3	Pin (pin 2)	X	1

NOTES * Ship S/N 13159 and subsequent.

Continues

FIGURE AND INDEX NUMBER	PART NUMBER	DESCRIPTION	PARTS AVAIL	QTY PER ASSY
ELECTRIC FUEL PUMP INSTALLATION* (Cont'd)				
28-21-31	6505-04-06-SS	Adapter	X	1
32	AN833-6	Elbow (steel, black)	X	1
33	A729-33	Tube	X	1
34	MS21919WDG5	Clamp	X	1
35	MS21266-1N	Grommet (install using item 36)	X	A/R
36	B270-8qt	Adhesive	X	A/R
37	D288-1	Clip (Ref)		
38	D742-1	Support Assembly (Incl item 35)	X	1

NOTES * Ship S/N 13159 and subsequent.

Intentionally Blank

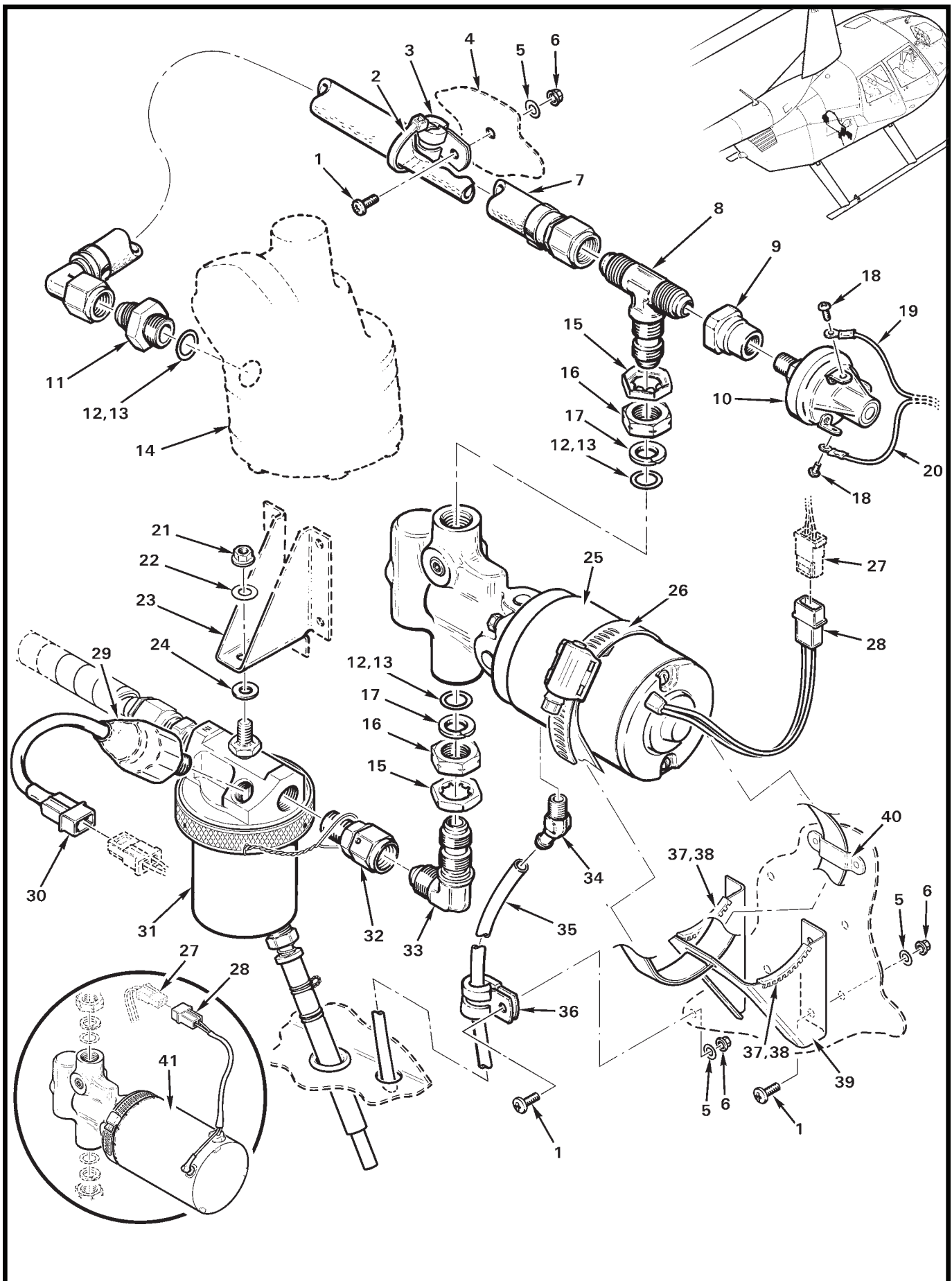

FIGURE AND INDEX NUMBER	PART NUMBER	DESCRIPTION	PARTS AVAIL	QTY PER ASSY
ELECTRIC FUEL PUMP INSTALLATION*				
28-25-1	MS27039C0806	Screw	X	6
2	MS3367-5-9	Ty-Rap	X	1
3	MS21919WDG3	Clamp	X	1
4	C233-1	Firewall – Vertical (Ref)		
5	NAS1149FN816P	Washer	X	6
6	MS21042L08	Nut	X	6
7	B283-3	Hose Assembly	X	1
8	AN834-6D	Tee	X	1
9	D744-1	Adapter	X	1
10	B426-2	Pressure Switch (Incl item 18)	X	1
11	MS21900D6	Adapter	X	1
12	MS29512-06	Packing (o-ring; lubricate with item 13)	X	3
13	A257-6	Grease	X	A/R
14	—	Fuel Pump (engine-driven; Ref)		
15	B330-25	Palnut	X	2
16	D452-6	Nut	X	2
17	D454-6	Retainer	X	2
18	—	Screw	O	2
19	C059-1542	Wire (Ref)		
20	C059-1530	Wire (Ref)		
21	MS21042L4	Nut (Ref)		
22	NAS1149F0463P	Washer (Ref)		
23	A454-1	Support (Ref)		
24	NAS1149F0432P	Washer	X	A/R
25	D743-1 **	Pump Assembly (Ref)		
26	HTM-300	Clamp	X	1
27	B263-13	Housing (Ref)		
28	B263-12	Housing	X	1
	B263-1	Pin	X	2
29	D745-1	Switch Assembly – Vacuum (Incl item 30)	X	1
30	B263-12	Housing	X	1
	B263-1	Pin	X	2

NOTES * Originally installed in ship S/N 10001 thru 13158.
 ** No longer available. Order KI-206-3 Kit for replacement.

Continues

FIGURE AND INDEX NUMBER	PART NUMBER	DESCRIPTION	PARTS AVAIL	QTY PER ASSY
ELECTRIC FUEL PUMP INSTALLATION* (Cont'd)				
28-25-31	A666-1	Gascolator (Ref; see Figure 28-19)		
32	6505-04-06-SS	Adapter	X	1
33	AN833-6D	Elbow	X	1
34	AN844-4D	Elbow	X	1
35	A729-33	Tube	X	1
36	MS21919WDG5	Clamp	X	1
37	MS21266-1N	Grommet (install using item 38)	X	A/R
38	B270 8qt	Adhesive	X	A/R
39	D742-1	Support (Incl item 37)	X	1
40	D288-1	Clip (Ref)		
41	D743-2**	Pump Assembly with shield (Ref; ENG/Police ships only)		

NOTES * Originally installed in ship S/N 10001 thru 13158.
 ** No longer available. Order KI-206-6 Kit for replacement.

Intentionally Blank

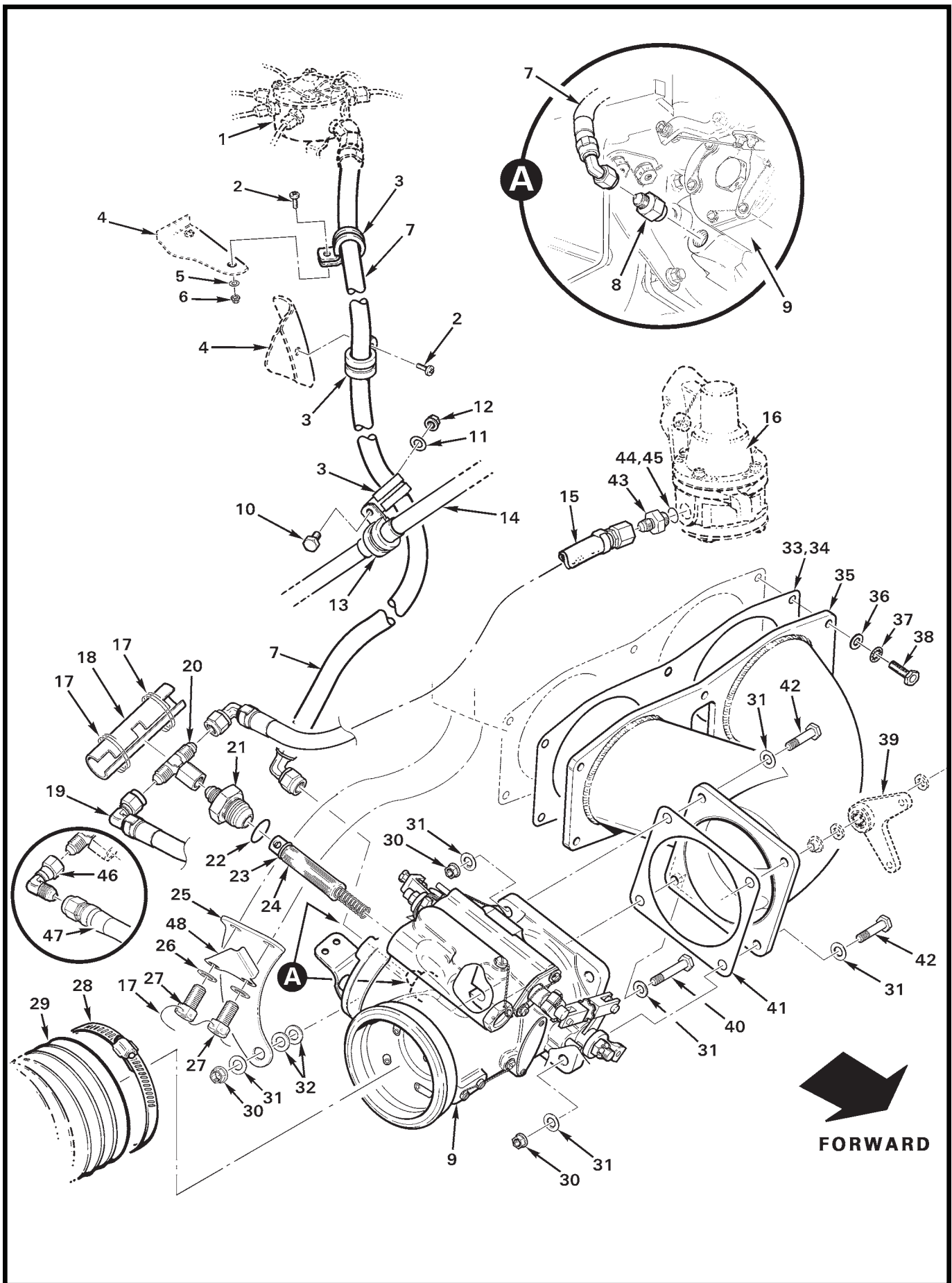

FIGURE AND INDEX NUMBER	PART NUMBER	DESCRIPTION	PARTS AVAIL	QTY PER ASSY
		FUEL CONTROL (SERVO) INSTALLATION*		
28-29-1	63B26710**	Manifold Assembly – Fuel (Ref)		
	2576526-1***	Flow Divider (Ref)		
2	MS27039C0806	Screw	X	1
3	MS21919WDG9	Clamp (or MS21919WDG11 as required to fit)	X	2
4	D382-1	Cover Assembly (RH, Ref)		
5	NAS1149FN816P	Washer	X	1
6	MS21042L08	Nut	X	1
7	B283-7	Hose (outlet, to flow divider)	X	1
8	2522710	Fitting – Outlet	X	1
9	2576630-4***	Fuel Control (Ref)		
10	AN3-3A	Bolt	X	1
11	NAS1149F0332P	Washer	X	1
12	MS21042L3	Nut	X	1
13	NAS1715C8SW	Clamp	X	1
14	A723-15	Oil Line (Ref)		
15	B283-10	Hose (inlet, from engine-driven fuel pump)	X	1
16	—	Fuel Pump (engine-driven; Ref)		
17	MS20995C32	0.032 in. dia. Safety Wire	X	A/R
18	D735-1	Sleeve	X	1
19	B283-11	Hose (fuel return, Ref; see Figure 28-33)		
20	A457-9	Tee	X	1
21	2577202***	Fitting (Ref)		
22	951790***	O-Ring	X	1
23	951392***	O-Ring	X	1
24	—	Screen/Filter (Ref)		
25	D730-8	Brace	X	1
26	NAS1149F0632P	Washer	X	2
27	MS20074-06-05	Bolt	X	2
28	B277-56	Clamp (Ref, see Figure 71-17)		
29	A785-31	Hose (Ref, see Figure 71-17)		
30	MS21042L5	Nut	X	3

NOTES * Ship S/N 10001 thru 29999.
 ** Lycoming part no.
 *** Avstar Fuel Systems part no.

Continues

FIGURE AND INDEX NUMBER	PART NUMBER	DESCRIPTION	PARTS AVAIL	QTY PER ASSY
FUEL CONTROL (SERVO) INSTALLATION* (Cont'd)				
28-29-31	NAS1149F0532P	Washer	X	6
32	NAS1149F0563P	Washer	X	2
33	72210**	Gasket (install using item 34)	X	1
34	B270-23	Sealant	X	A/R
35	D730-1	Intake Manifold Weldment	X	1
36	STD-8*	Washer	X	6
37	STD-160**	Washer (internal teeth)	X	6
38	LW-25-0.81**	Bolt	X	6
39	D731-9	Bellcrank (Ref, see Figure 76-5)		
40	NAS6605-13	Bolt	X	1
41	73032**	Gasket	X	1
42	NAS6605-11	Bolt	X	2
43	LW-16561	Nipple	X	1
44	MS29512-06	Packing (o-ring; install using item 45)	X	1
45	A257-6	Grease	X	A/R
46	6500-04-04-SS***	Elbow	X	1
47	B283-9***	Hose (fuel return; Ref)		
48	C730-1	Guard	X	1

NOTES * Ship S/N 10001 thru 29999.
 ** Lycoming part no.
 *** Installed on earlier R44s.

Intentionally Blank

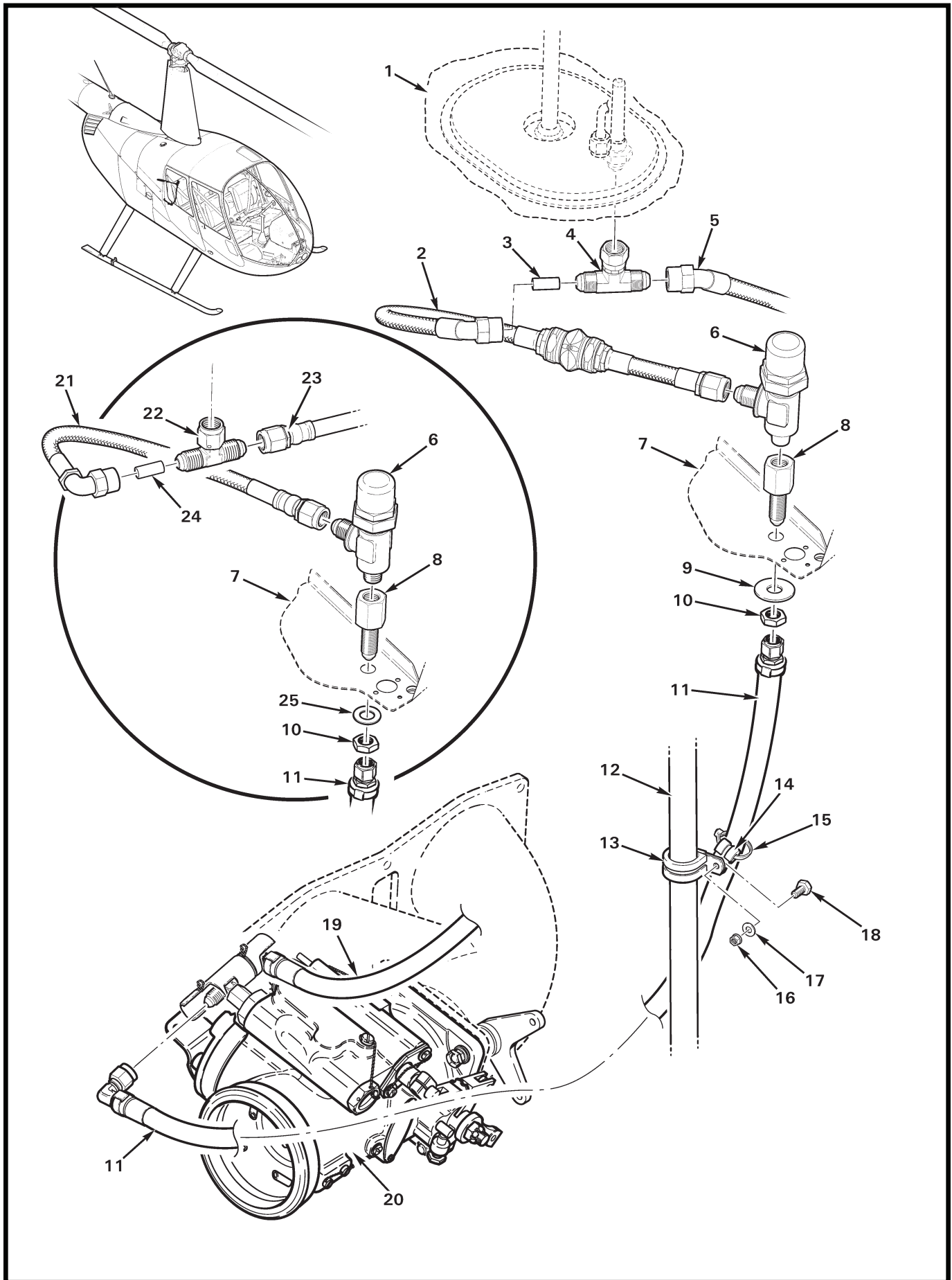

FIGURE AND INDEX NUMBER	PART NUMBER	DESCRIPTION	PARTS AVAIL	QTY PER ASSY
		RETURN HOSE INSTALLATION*		
28-33-1	D043-5	Aux Fuel Tank Assembly (Ref)		
2	C595-4	Hose Assembly (Ref)		
3	D453-5	Jet (Ref)		
4	D453-4	Tee	X	1
5	C595-3	Hose Assembly (Ref)		
6	D321-1	Valve Assembly – Pressure Relief	X	1
7	C234-1	Firewall – Horizontal (Ref)		
8	A457-13	Connector	X	1
	2705-04-04	Connector	O	1
	4-4WGTX-S	Connector	O	1
9	C141-5	Washer	X	1
10	AN316-7R	Nut	X	1
11	B283-11	Hose Assembly (fuel return)	X	1
12	C046-2	Lower Frame Assembly (RH, Ref)		
13	MS21919WDG14	Clamp	X	1
14	MS21919WDG3	Clamp	X	1
15	MS3367-5-9	Ty-Rap	X	1
16	D210-3	Nut	X	1
17	NAS1149F0332P	Washer	X	1
18	AN3-3A	Bolt	X	1
19	B283-10	Hose Assembly (inlet, from engine driven fuel pump; Ref)		
20	AV2576630-4	Fuel Control (Ref)		
	2576630-4	Fuel Control (Ref)		
21	D205-31	Hose Assembly (Ref)		
22	D453-3	Tee	X	1
23	D205-29	Hose Assembly (Ref)		
24	D453-2	Jet (Ref)		
25	NAS1149F0732P	Washer	X	1

NOTES * Ship S/N 10001 thru 29999.

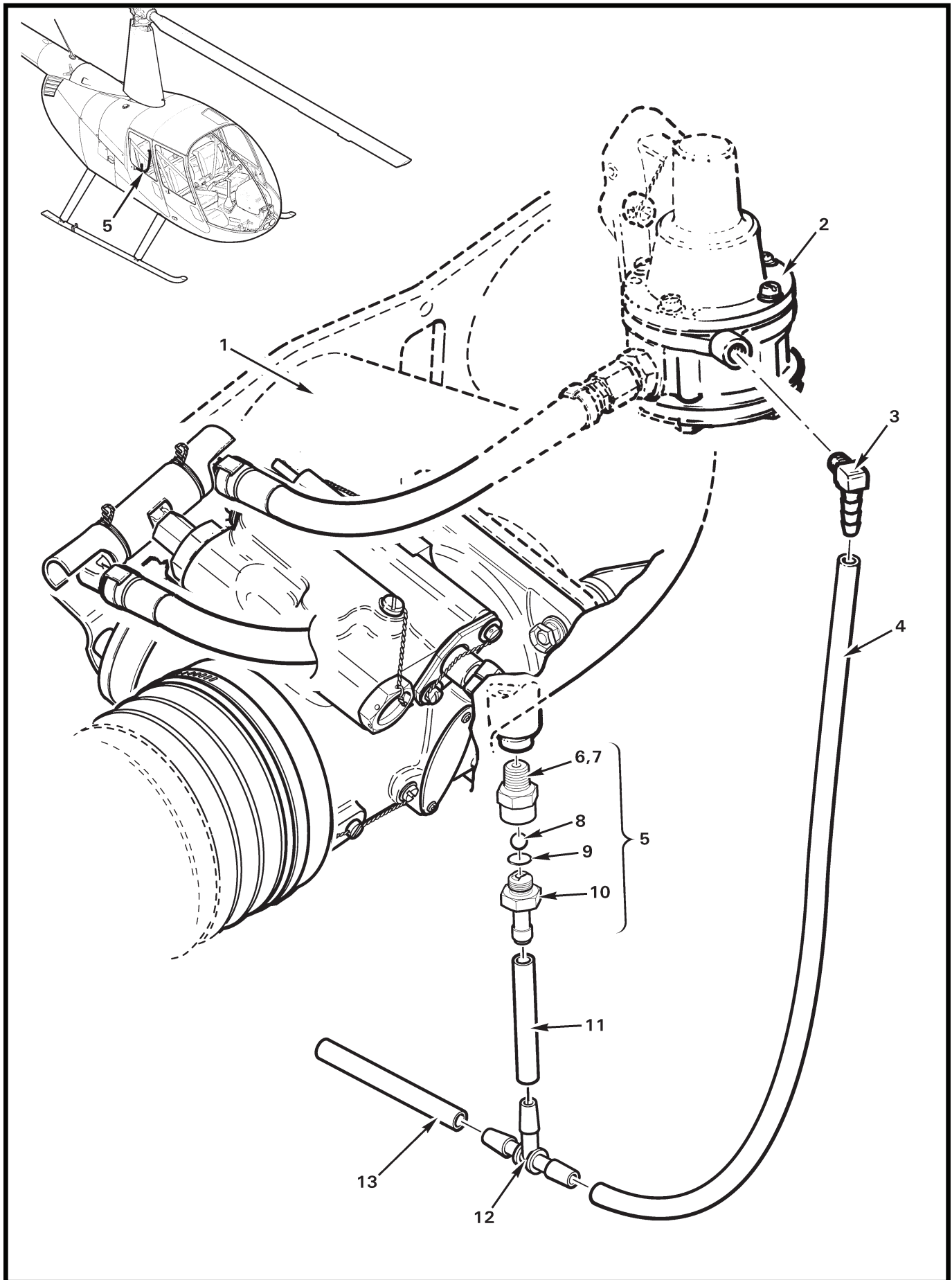

FIGURE AND INDEX NUMBER	PART NUMBER	DESCRIPTION	PARTS AVAIL	QTY PER ASSY
INTAKE MANIFOLD DRAIN INSTALLATION*				
28-35-1	D730-1	Manifold Weldment (Ref)		
2	62B26931**	Fuel Pump – Mechanical (Ref)		
	LW-15473**	Fuel Pump – Mechanical (Ref)		
3	A457-10	Elbow	X	1
	129HB-4-2	Elbow (superseded by A457-10)	O	1
4	A729-34	Tube	X	1
5	D775-1	Drain Valve – Fuel (Incl items 7 thru 10; apply item 6 to pipe threads)	X	1
6	B270-6	Sealant	X	A/R
7	D775-2	Housing	X	1
8	B208-4	Ball	X	1
9	MS28775-011	Packing	X	1
10	D775-3	Drain (torque to 90 in.-lb)	X	1
11	A729-35	Tube	X	1
12	A457-6	Tee	X	1
13	A729-36	Tube	X	1

NOTES * Ship S/N 10001 thru 29999.
 ** Lycoming part no.

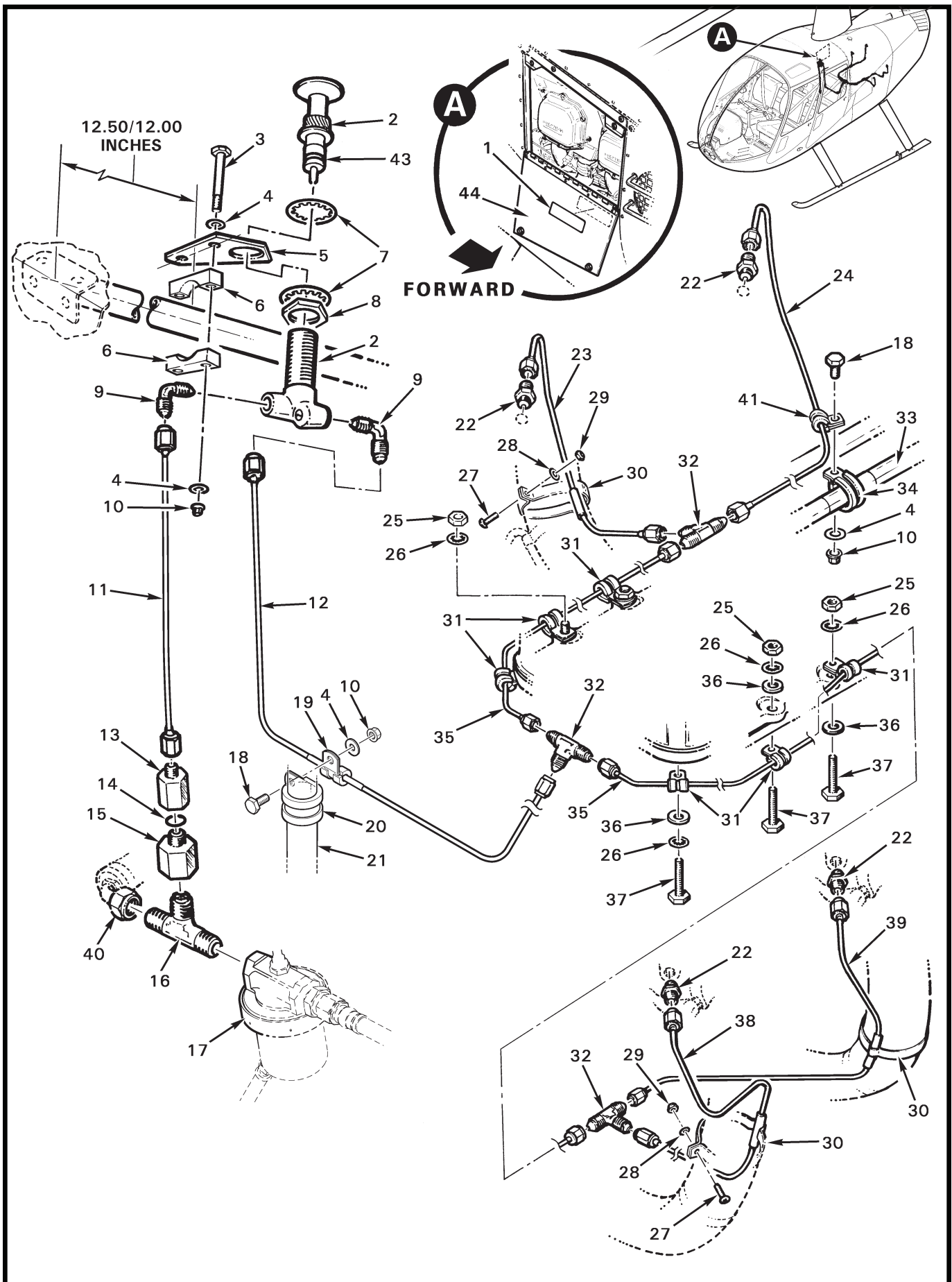

FIGURE AND INDEX NUMBER	PART NUMBER	DESCRIPTION	PARTS AVAIL	QTY PER ASSY
PRIMER SYSTEM*				
28-37-1	C654-49	Decal ("Caution")	X	1
2	10950	Pump (Incl item 8 and 43)	X	1
3	NAS6603-26	Bolt	X	2
4	NAS1149F0332P	Washer	X	6
5	D420-3	Plate	X	1
6	D420-1	Block	X	2
7	MS35333-46	Lockwasher	X	2
8	—	Nut	O	1
9	A880-602	Elbow (install using item 42)	X	2
10	D210-3	Nut	X	6
11	D101-3	Line Assembly	X	1
12	D102-4	Line Assembly	X	1
13	AN894D4-2	Bushing	X	1
14	MS29512-4	Gasket	X	1
15	AN894D6-4	Bushing	X	1
16	A880-1136	Tee (or A880-1166; install using item 42)	X	1
17	A666-1	Gascolator (Ref)		
18	AN3-3A	Bolt	X	1
19	MS21919WDG4	Clamp	X	1
20	MS21919WDG12	Clamp	X	1
21	C727-2	Engine Breather Tube (Ref)		
	C728-2	Separator Assembly (Ref, not shown)		
22	B310-2	Injector	X	4
23	D104-3	Line Assembly	X	1
24	D105-3	Line Assembly	X	1
25	—	Nut (Ref; supplied with engine)		
26	—	Lockwasher (Ref; supplied with engine)		
27	MS35206-230	Screw	X	3
28	NAS1149FN616P	Washer	X	3
29	MS21042L06	Nut	X	3
30	LW-18959-175-25**	Clamp	X	3

NOTES * Frame-mounted primer pump, ship S/N 0358 and subsequent.
 ** Lycoming part no.

Continues

FIGURE AND INDEX NUMBER	PART NUMBER	DESCRIPTION	PARTS AVAIL	QTY PER ASSY
PRIMER SYSTEM* (Cont'd)				
28-37-31	MS21333-96	Clamp (install using items 25, 26, 36, and 37 as required) . . .	X	6
32	MS24402-2D	Tee	X	3
33	A723-16	Oil Line (Ref)		
	A723-10	Oil Line (Ref; superseded by A723-16)		
34	MS21919WCH8	Clamp	X	1
35	D103-3	Line Assembly	X	2
36	—	Washer – Flat (Ref, supplied with engine)		
37	—	Bolt (Ref, supplied with engine)		
38	D106-3	Line Assembly	X	1
39	D107-3	Line Assembly	X	1
40	B283-3	Hose Assembly – Fuel (Ref, see also Figures 28-21 and 28-25)		
41	MS21919WDG2	Clamp	X	1
42	B270-6	Sealant	X	A/R
43	—	O-Ring	O	2
44	C364-7	Door – Cowl (Ref)		
* * *				
45	KI-127	R44 Primer Pump Location Upgrade Kit (Fuel Primer; Ship S/N 0001 thru 0357. Includes items 1 thru 7, 9 thru 12, 18 thru 20, 28, 29, 42, and 46 thru 51.)	X	1
46	2590**	Hole Plug	X	10
47	2617**	Hole Plug	X	1
48	2633**	Hole Plug	X	1
49	A231-5**	Cover	X	1
50	A231-8**	Retainer	X	1
51	MS35206-227**	Screw	X	1

NOTES * Frame-mounted primer pump, ship S/N 0358 and subsequent.
 ** Not shown; included in KI-127 kit.

Intentionally Blank

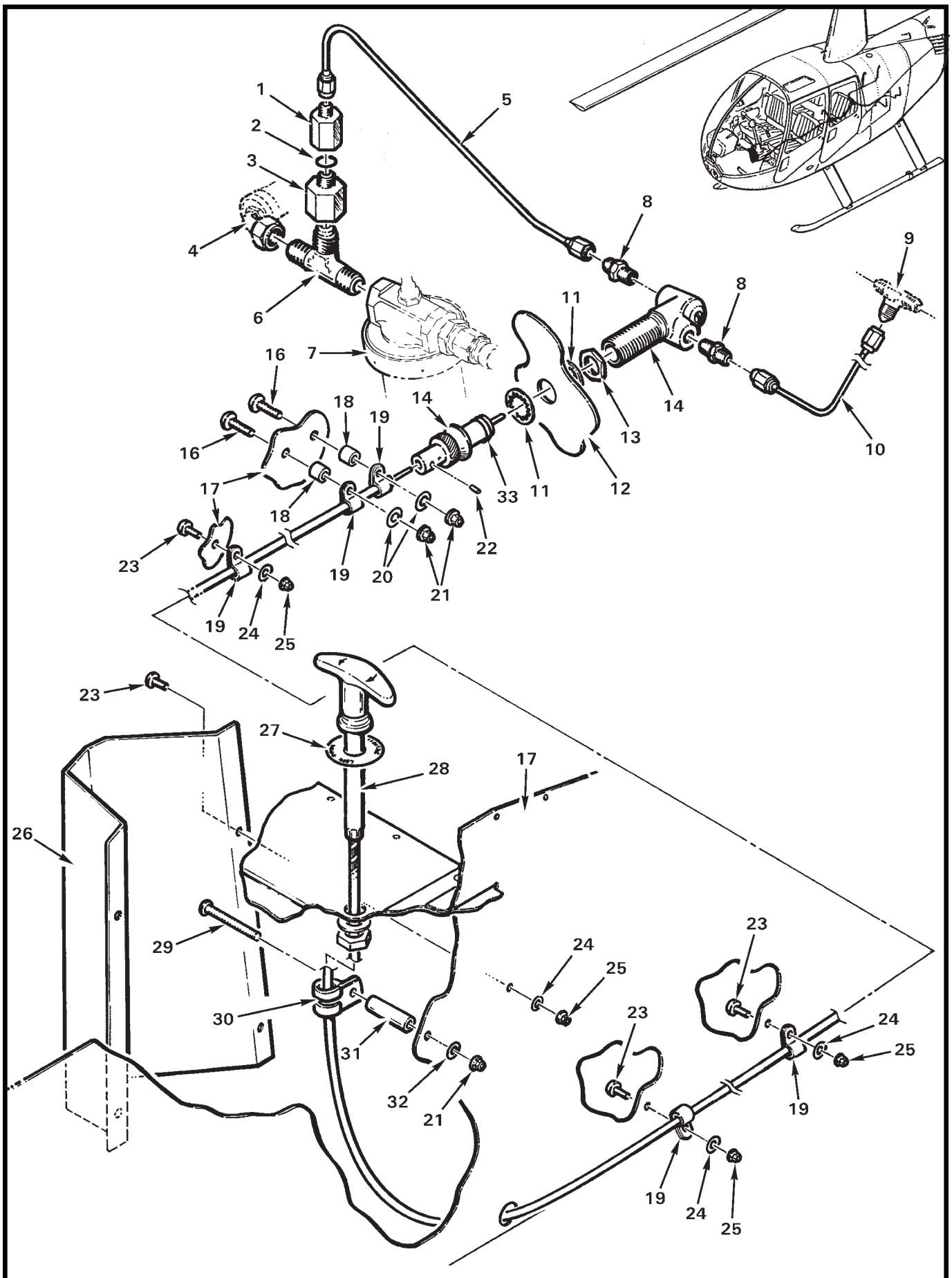

FIGURE AND INDEX NUMBER	PART NUMBER	DESCRIPTION	PARTS AVAIL	QTY PER ASSY
PRIMER PUMP INSTALLATION*				
28-41-1	AN894D4-2	Bushing	X	1
2	MS29512-04	Gasket	X	1
3	AN894D6-4	Bushing	X	1
4	B283-3	Hose Assembly Fuel (Ref)		
5	D101-1	Line Assembly	X	1
6	MS20826-6D	Tee (install using item 15)	X	1
7	A666-1	Gascolator (Ref)		
8	AN816-2D	Nipple (Ref, no longer available)		
9	MS24402-2D	Tee (Ref, see Figure 28-37)		
10	D102-3	Line Assembly	X	1
11	MS35333-46	Lockwasher	X	2
12	—	Firewall (Ref)		
13	—	Nut	O	1
14	D120-1**	Pump (Ref, includes item 33)		
15	B270-6	Sealant (4-oz tube, for pipe threads)	X	A/R
16	MS27039C1-14	Screw	X	2
17	C292-2	Keel Panel (Ref)		
18	A130-35	Spacer	X	2
19	AN742-3	Clamp	X	5
20	NAS1149F0363P	Washer	X	2
21	MS21042L3	Nut	X	3
22	28704L-98C-3	Set Screw	X	1
23	MS27039C0806	Screw	X	7
24	NAS1149FN816P	Washer	X	7
25	MS21042L08	Nut	X	7
26	D121-1**	Cover (Ref)		
27	D121-2	Escutcheon (Ref, no longer available)		
28	D522-1**	Control (Ref)		
29	MS27039C1-27	Screw	X	1
30	MS21919WDG6	Clamp	X	1
31	A130-27	Spacer	X	1
32	NAS1149F0332P	Washer	X	1
33	AS568-012	O-Ring (Ref)	O	2

NOTES * Ship S/N 0001 thru 0357. See Figure 28-37.
 ** No long available; order KI-127 Location Upgrade Kit. See Figure 28-37 (item 45).

Intentionally Blank

CHAPTER 29

HYDRAULICS

<i>Figure</i>	<i>Title</i>	<i>Page</i>
29-1	Forward Servos Installation	29.0
29-3	Aft Servo Installation	29.2
29-7	Hydraulic Reservoir Installation	29.6
29-11	Hydraulic Reservoir Installation	29.10
29-15	Forward Servo Hoses Installation	29.14
29-17	Hydraulic Pump Installation	29.16

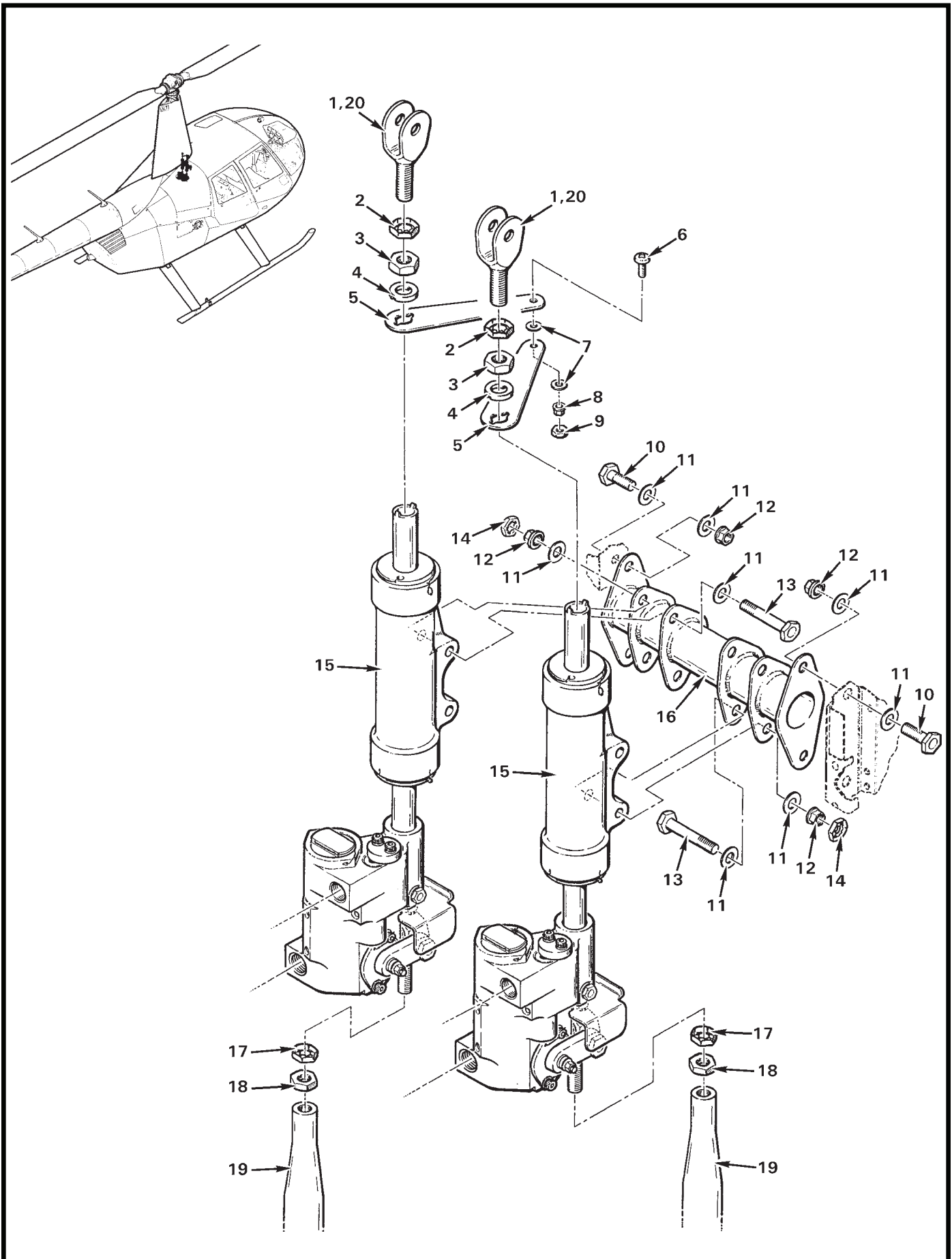

FIGURE AND INDEX NUMBER	PART NUMBER	DESCRIPTION	PARTS AVAIL	QTY PER ASSY
FORWARD SERVOS INSTALLATION				
29-1-1	D200-1	Clevis (install using item 20)	X	2
2	B330-19	Palnut	X	2
3	AN316-6R	Nut	X	2
4	D200-3	Washer	X	2
5	D200-2	Scissor	X	2
6	MS27039C0806	Screw	X	1
7	NAS1149FN832P	Washer	X	2
8	D210-08	Nut	X	1
9	B330-6	Palnut	X	1
10	NAS6604-2	Bolt	X	4
11	NAS1149F0432P	Washer	X	16
12	D210-4	Nut	X	8
13	NAS6604-16	Bolt	X	4
14	B330-13	Palnut	X	4
15	D212-1	Servo Assembly (forward; includes items 17 and 18)	X	2
	D212-1R	D212-1 Servo Assembly (overhaul exchange)	X	2
16	D201-5	Support (supersedes D201-1; must use D201-5 on R44 II)	X	1
17	B330-16	Palnut	X	2
18	AN316-5R	Nut	X	2
19	C121-28	Push-Pull Tube (Ref, see Figure 67-27; ship S/N 1001 and subsequent.)		
	C121-24	Push-Pull Tube (Ref, see Figure 67-31; ship S/N 1000 and prior.)		
20	B270-21	Protectant	X	A/R

NOTES

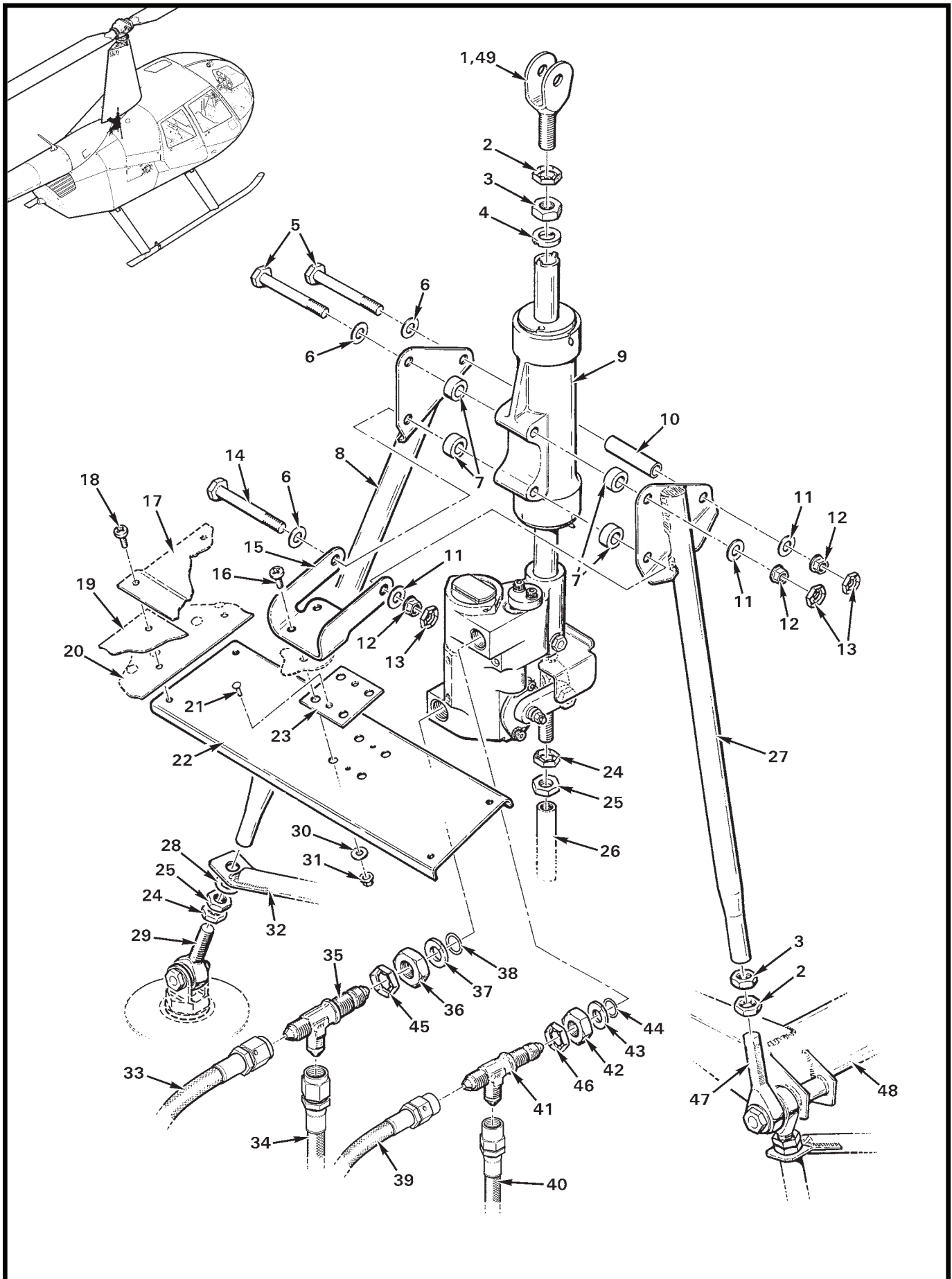

FIGURE AND INDEX NUMBER	PART NUMBER	DESCRIPTION	PARTS AVAIL	QTY PER ASSY
AFT SERVO INSTALLATION				
29-3-1	D200-1	Clevis	X	1
2	B330-19	Palnut	X	2
3	AN316-6R	Nut	X	2
4	D200-3	Washer	X	1
5	NAS6604-24	Bolt	X	2
6	NAS1149F0432P	Washer	X	3
7	C130-15	Spacer	X	4
8	D203-1	Support – LH	X	1
9	D212-1	Servo Assembly	X	1
	D212-1R	D212-1 Servo Assembly (overhaul exchange)	X	1
10	C130-14	Spacer	X	1
11	NAS1149F0463P	Washer	X	3
12	D210-4	Nut	X	3
13	B330-13	Palnut	X	3
14	NAS6604-25	Bolt	X	1
15	D202-4	Bracket Assembly	X	1
16	MS27039C0807	Screw (or MS27039C0808)	X	8
17	C347-6	Panel (Ref, see Figure 53-15)		
18	MS27039C0807	Screw	X	4
19	C706-1	Tailcone Fairing (Ref, see Figure 53-13)		
20	C028-1	Main Fuel Tank (Ref, see Figure 28-1)		
21	NAS1097AD3	Rivet	X	2
22	D202-1	Channel (see also Figure 53-15)	X	1
23	D202-3	Shim	X	A/R
24	B330-16	Palnut	X	2
25	AN316-5R	Nut	X	2
26	C343-8	Tube (Ref, see Figure 67-53)		
27	D204-8	Support – RH (Supersedes D204-1; must use D204-8 on R44 II.)	X	1
28	NAS1149F0532P	Washer	X	1
29	A101-4	Rod End (Ref)		
30	NAS1149FN832P	Washer	X	4

NOTES

Continues

FIGURE AND INDEX NUMBER	PART NUMBER	DESCRIPTION	PARTS AVAIL	QTY PER ASSY
AFT SERVO INSTALLATION (Cont'd)				
29-3-31	MS21042L08	Nut	X	4
32	D208-1	Weldment (Ref, see Figure 67-53)		
33	D205-16	Hose (90° elbow at reservoir end)	X	1
	D205-6*	Hose (straight both ends)	X	1
34	D205-7	Hose	X	1
35	AN804D4	Tee	X	1
36	D452-4	Nut	X	1
37	D454-4	Retainer (reusable, supersedes MS28773-04)	X	1
38	MS28778-4	Packing (o-ring)	X	1
39	D205-12	Hose (90° elbow at reservoir end)	X	1
	D205-2*	Hose (straight both ends)	X	1
40	D205-3	Hose	X	1
41	AN804D3	Tee	X	1
42	D452-3	Nut	X	1
43	D454-3	Retainer (reusable, supersedes MS28773-03)	X	1
44	MS28775-011	Packing (o-ring)	X	1
45	B330-21	Palnut	X	1
46	B330-19	Palnut	X	1
47	D173-1	Rod End (Ref)		
48	C339-10	Jackshaft Weldment (Ref, see Figure 67-53)		
49	B270-21	Protectant	X	A/R

NOTES * Installed on earlier R44s. See also Figure 29-7.

Intentionally Blank

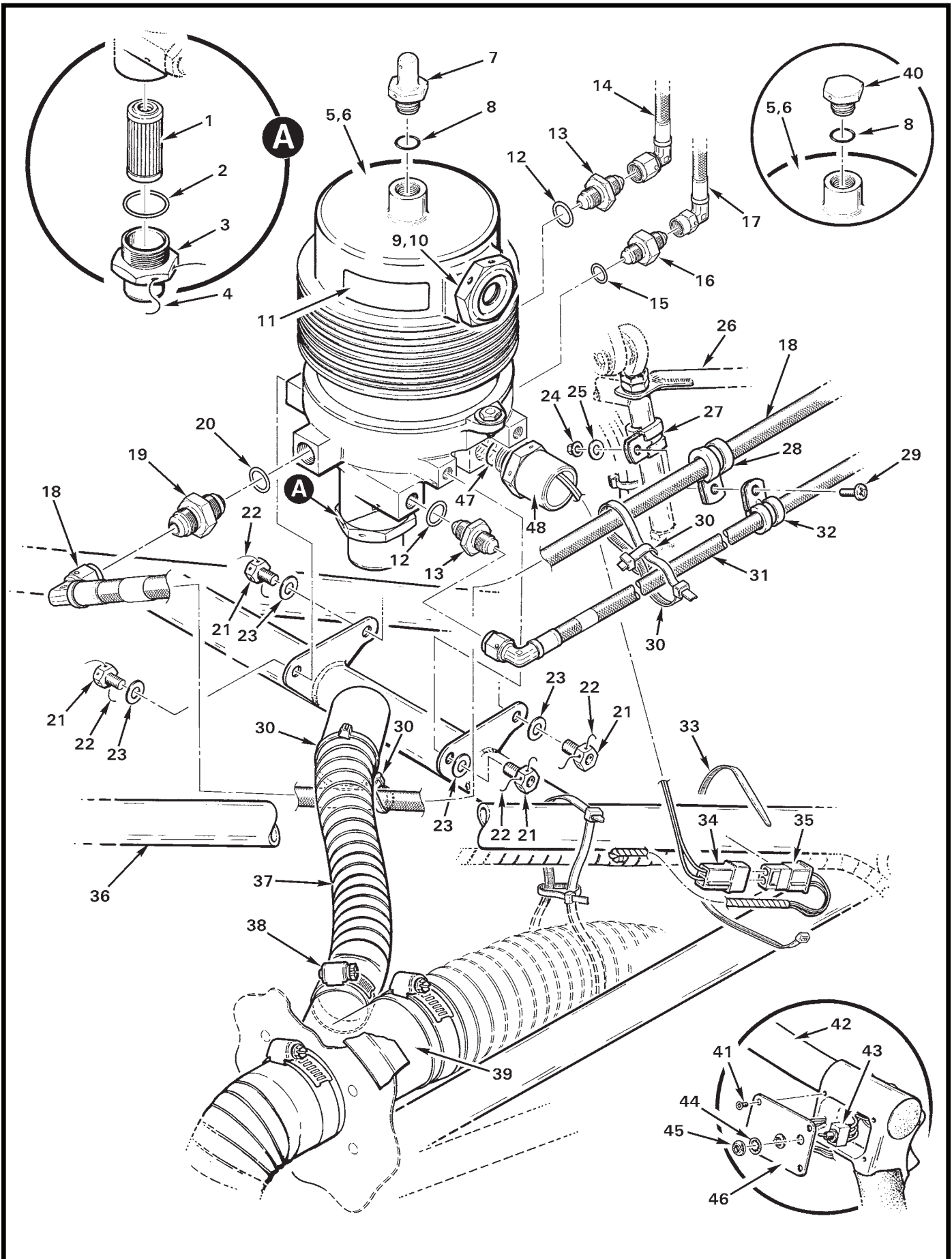

FIGURE AND INDEX NUMBER	PART NUMBER	DESCRIPTION	PARTS AVAIL	QTY PER ASSY
HYDRAULIC RESERVOIR INSTALLATION*				
29-7-1	AN6235-1A	Filter	X	1
2	MS28778-14	Packing (o-ring)	X	1
3	D516-1	Cap	X	1
4	MS20995C20	0.020 in. dia. Safety Wire (for earlier R44s)	X	A/R
5	D211-1	Reservoir Assembly (14-volt ships. Includes items 1 thru 4, 7 thru 11, 47, and 48.)	X	1
	D211-1R	D211-1 Reservoir Assembly (overhaul exchange)	X	1
	D211-2	Reservoir Assembly (28-volt ships. Includes items 1 thru 4, 7 thru 11, 47, and 48.)	X	1
	D211-2R	D211-2 Reservoir Assembly (overhaul exchange)	X	1
6	A257-15	Hydraulic Fluid (one-quart bottle)	X	A/R
7	D487-3	Filler - Vent Plug	X	1
8	MS28778-5	Packing (o-ring)	X	1
9	B563-3	Sight Gauge (supersedes S50P and B563-2)	X	1
10	MS28775-020	Packing (o-ring; not shown)	X	1
11	C654-37	Decal (hydraulic fluid fill instructions)	X	1
12	MS28778-4	Packing (o-ring)	X	2
13	AN815-4D	Union	X	2
14	D205-16	Hose	X	1
15	MS28775-011	Packing (o-ring)	X	1
16	AN815-3D	Union	X	1
17	D205-12	Hose	X	1
18	D205-15	Hose	X	1
19	AN815-6D	Union	X	1
20	MS28778-6	Packing (o-ring)	X	1
21	MS20074-04-03	Bolt	X	4
22	MS20995C32	0.032 in. dia. Safety Wire (for earlier R44s)	X	A/R
23	NAS1149F0432P	Washer	X	4
24	MS21042L08	Nut	X	1
25	NAS1149FN832P	Washer	X	1
26	C345-5	Weldment (Ref, see Figure 67-53)		
27	MS21919WDG8	Clamp	X	1

NOTES * Ship S/N 1001 and subsequent.

Continues

FIGURE AND INDEX NUMBER	PART NUMBER	DESCRIPTION	PARTS AVAIL	QTY PER ASSY
HYDRAULIC RESERVOIR INSTALLATION* (Cont'd)				
29-7-28	MS21919WDG7	Clamp	X	1
29	MS27039C0807	Screw	X	1
30	MS3367-5-9	Ty-Rap ([2] at each location as shown)	X	4
31	D205-11	Hose	X	1
32	MS21919WDG5	Clamp	X	1
33	MS3367-5-9	Ty-Rap (or MS3367-7-9; wires and hoses)	X	A/R
34	B263-12	Housing (14-volt ships)	X	1
	B263-14	Housing (28-volt ships)	X	1
	B263-1	Pin	X	2
35	B263-13	Housing (14-volt ships)	X	1
	B263-15	Housing (28-volt ships)	X	1
	B263-2	Socket	X	2
36	C020	Upper Frame Assembly (Ref)		
37	A785-28	Hose	X	1
38	B277-28	Clamp	X	1
39	C371	Tube Assembly (Ref)		
40	D487-1	Filler - Vent Plug (Ref, no longer available. Superseded by item 7.)		
41	MS24693-S2	Screw	X	1
42	C058	Cyclic Grip Assembly (Ref, see also Figure 97-15)		
43	B300-3	Switch Assembly - Hydraulic (Incl items 44 and 45)	X	1
44	B227-3	Lockwasher	X	1
45	B227-4	Dress Nut	X	1
46	C214	Plate (Ref, see Figure 67-11)		
47	A215-907	O-Ring	X	1
48	D507-1	Solenoid Assembly (14-volt; includes item 34 [B263-12 and -1])	X	1
	D507-2	Solenoid Assembly (28-volt; includes item 34 [B263-14 and -1]; not shown)	X	1

NOTES * Ship S/N 1001 and subsequent.

Intentionally Blank

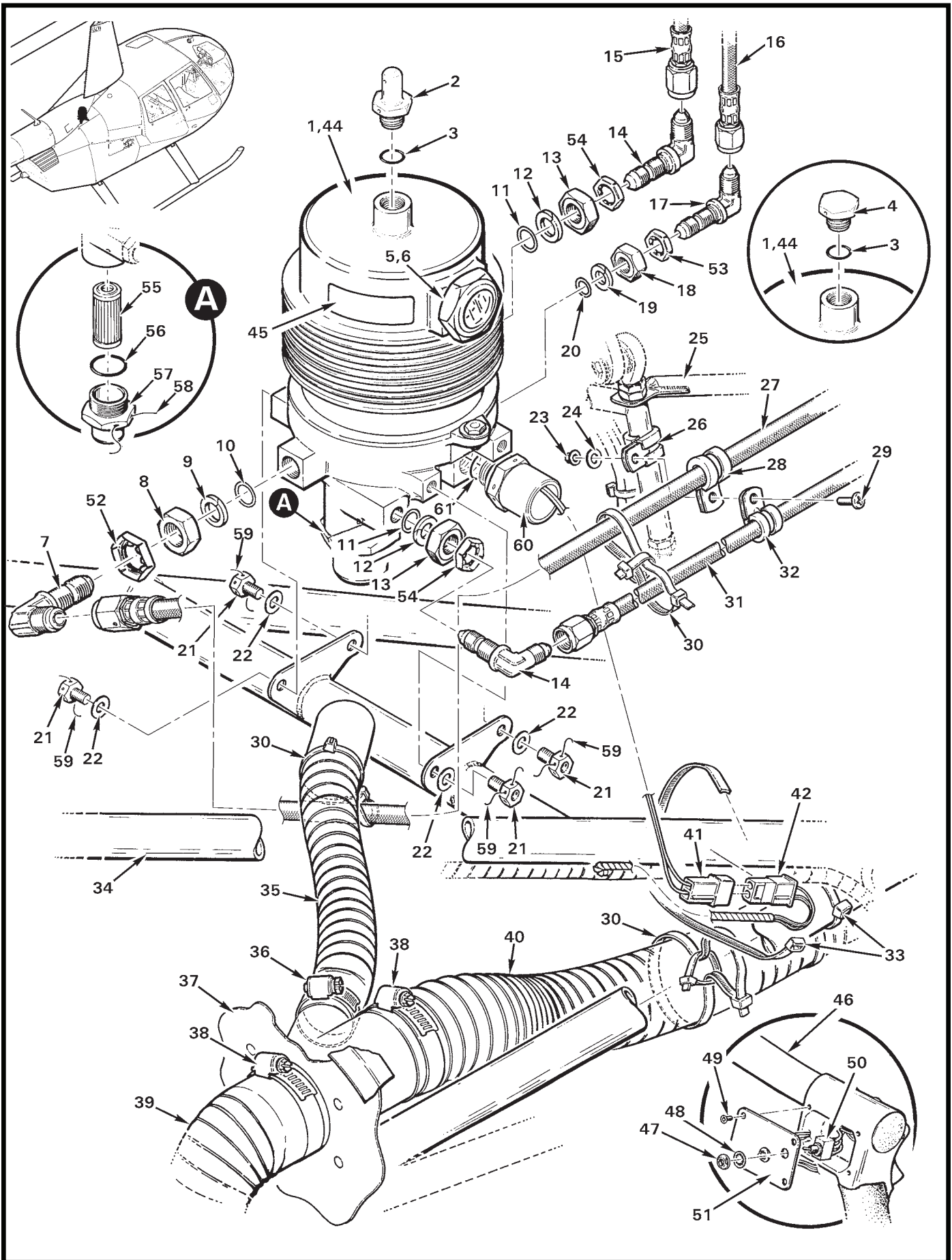

FIGURE AND INDEX NUMBER	PART NUMBER	DESCRIPTION	PARTS AVAIL	QTY PER ASSY
		HYDRAULIC RESERVOIR INSTALLATION*		
29-11-1	D211-1	Reservoir Assembly (14-volt ships. Includes items 2 thru 6, 55 thru 58, and 61.)	X	1
	D211-1R	D211-1 Reservoir Assembly (overhaul exchange)	X	1
	D211-2	Reservoir Assembly (28-volt ships. Includes items 2 thru 6, 55 thru 58, and 61.)	X	1
	D211-2R	D211-2 Reservoir Assembly (overhaul exchange)	X	1
2	D487-3	Filler - Vent Plug	X	1
3	MS28778-5	Packing (o-ring)	X	1
4	D487-1	Filler - Vent Plug (Ref, no longer available. Superseded by item 2.)		
5	B563-3	Sight Gauge (supersedes S50P and B563-2)	X	1
6	MS28775-020	Packing (o-ring; not shown)	X	1
7	AN833-6D	Elbow	X	1
8	D452-6	Nut	X	1
9	D454-6	Retainer (supersedes MS28773-06)	X	1
10	MS28778-6	Packing (o-ring)	X	1
11	MS28778-4	Packing (o-ring)	X	2
12	D454-4	Retainer (supersedes MS28773-04)	X	2
13	D452-4	Nut	X	2
14	AN833-4D	Elbow	X	1
15	D205-6	Hose	X	1
16	D205-2	Hose	X	1
17	AN833-3D	Elbow	X	2
18	D452-3	Nut	X	1
19	D454-3	Retainer (supersedes MS28773-03)	X	1
20	MS28775-011	Packing (o-ring; supersedes MS28778-3)	X	1
21	MS20074-04-03	Bolt	X	4
22	NAS1149F0432P	Washer	X	1
23	MS21042L08	Nut	X	1
24	NAS1149FN832P	Washer	X	1
25	D208-1	Weldment (Ref, see Figure 67-53)		
26	MS21919WDG8	Clamp	X	1

NOTES * Ship S/N 1000 and prior.

Continues

FIGURE AND INDEX NUMBER	PART NUMBER	DESCRIPTION	PARTS AVAIL	QTY PER ASSY
HYDRAULIC RESERVOIR INSTALLATION* (Cont'd)				
29-11-27	D205-15**	Hose (supersedes D205-5)	X	1
28	MS21919WDG7	Clamp	X	1
29	MS27039C0807	Screw	X	1
30	MS3367-5-9	Ty-Rap ([2] at each location as shown)	X	4
31	D205-1	Hose	X	1
32	MS21919WDG5	Clamp	X	1
33	MS3367-5-9	Ty-Rap (or MS3367-7-9; wires and hoses)	X	A/R
34	C020-1	Upper Frame Assembly (Ref)		
35	A785-28	Hose	X	1
36	B277-12	Clamp	X	1
37	C723-1	Bulkhead (Ref)		
38	B277-32	Clamp	X	3
39	A785-17	Hose (to scroll)	X	1
40	A785-6	Hose (to main rotor gearbox)	X	1
41	B263-12	Housing (14-volt ships)	X	1
	B263-1	Pin	X	2
	B263-14	Housing (28-volt ships)	X	1
	B263-1	Pin	X	2
42	B263-13	Housing (14-volt ships)	X	1
	B263-2	Socket	X	2
	B263-15	Housing (28-volt ships)	X	1
	B263-2	Socket	X	2
43	B161-2	Spirap	X	A/R
44	A257-15	Hydraulic Fluid (one-quart bottle)	X	A/R
45	C654-37	Decal (hydraulic fluid fill instructions)	X	1
46	C058-7	Cyclic Grip Assembly (Ref, see also Figure 97-15)		
47	B227-4	Dress Nut	X	1
48	B227-3	Lockwasher	X	1
49	MS24693-S2	Screw	X	1
50	B300-3	Switch Assembly - Hydraulic (Incl items 48 and 49)	X	1
51	C214	Plate (Ref, see Figure 67-11)		

NOTES * Ship S/N 1000 and prior.
 ** Order (1) AN815-6D union and (1) MS28778-6 packing with item 27 when replacing D205-5.

Continues

FIGURE AND INDEX NUMBER	PART NUMBER	DESCRIPTION	PARTS AVAIL	QTY PER ASSY
HYDRAULIC RESERVOIR INSTALLATION* (Cont'd)				
29-11-52	B330-25	Palnut	X	1
53	B330-19	Palnut	X	2
54	B330-21	Palnut	X	1
55	AN6235-1A	Filter	X	1
56	MS28778-14	Packing (o-ring)	X	1
57	D516-1	Cap	X	1
58	MS20995C20	0.020 in. dia. Safety Wire	X	A/R
59	MS20995C32	0.032 in. dia. Safety Wire	X	A/R
60	D507-1	Solenoid Assembly (14-volt ships)	X	1
	D507-2	Solenoid Assembly (28-volt ships)	X	1
61	A215-907	Packing (o-ring)	X	1

NOTES * Ship S/N 1000 and prior.

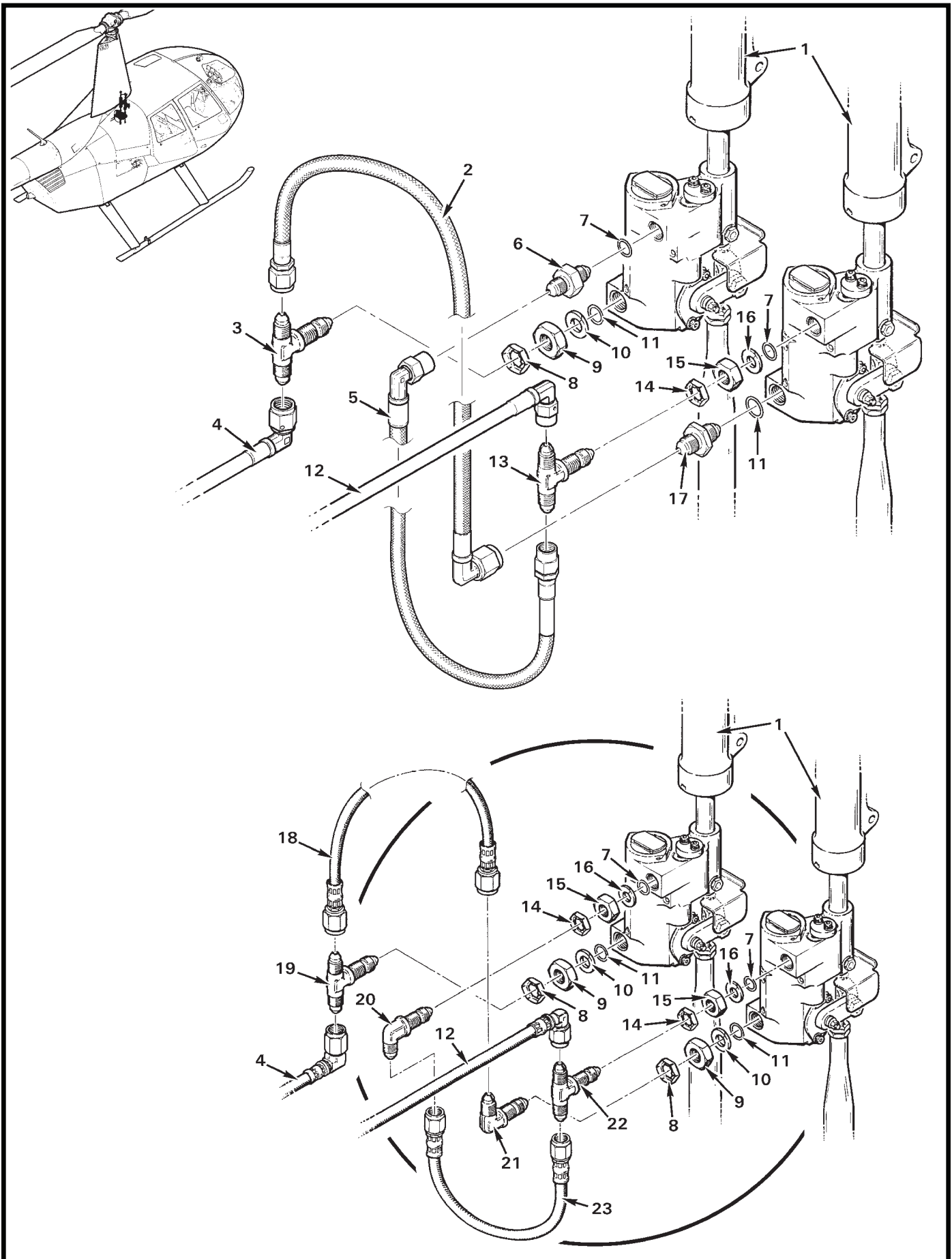

FIGURE AND INDEX NUMBER	PART NUMBER	DESCRIPTION	PARTS AVAIL	QTY PER ASSY
FORWARD SERVO HOSES INSTALLATION				
29-15-1	D212-1	Servo Assembly (Ref)		
2	D205-16	Hose	X	1
3	AN834D4	Tee	X	1
4	D205-7	Hose	X	1
5	D205-14	Hose	X	1
6	AN815-3D	Union	X	1
7	MS28775-011	Packing (o-ring)	X	2
8	B330-21	Palnut	X	1
9	D452-4	Nut	X	1
10	D454-4	Retainer (reusable, supersedes MS28773-04)	X	1
11	MS28778-4	Packing (o-ring)	X	2
12	D205-3	Hose	X	1
13	AN834D3	Tee	X	1
14	B330-19	Palnut	X	1
15	D452-3	Nut	X	1
16	D454-3	Retainer (reusable, supersedes MS28773-03)	X	1
17	AS5174D0404	Union	X	1
18	D205-6	Hose (No longer available. To replace, order items 2, 11, and 17.)	O	1
19	AN834D4	Tee	X	1
20	AN833-3D	Elbow	X	1
21	AN833-4D	Elbow	X	1
22	AN834D3	Tee	X	1
23	D205-4	Hose (No longer available. To replace, order items 5, 6, and 7.)	O	1

NOTES

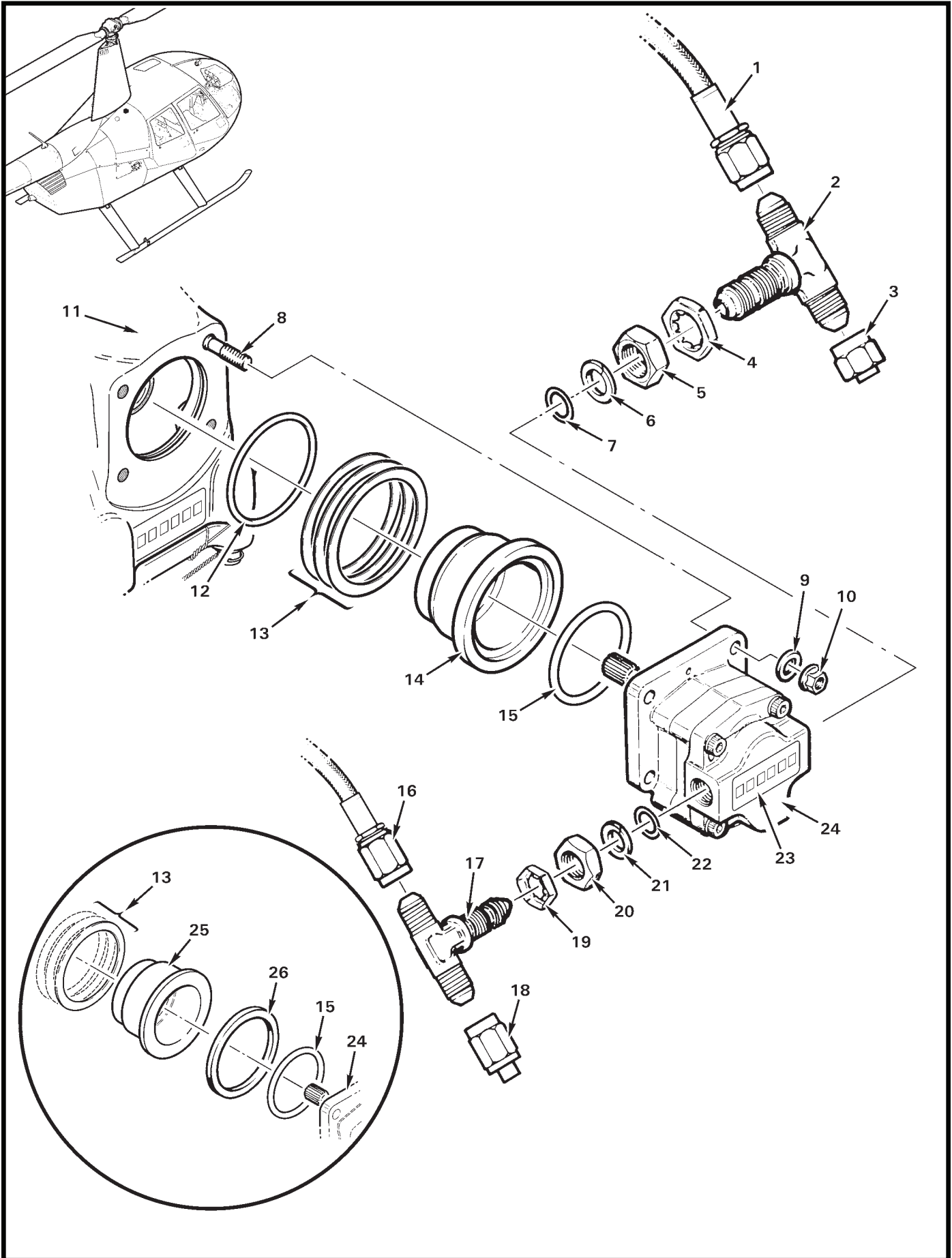

FIGURE AND INDEX NUMBER	PART NUMBER	DESCRIPTION	PARTS AVAIL	QTY PER ASSY
HYDRAULIC PUMP INSTALLATION				
29-17-1	D205-15	Hose (90° elbow at reservoir end)	X	1
	D205-5*	Hose (Straight both ends, no longer available. To replace, order D205-15 hose, [1] AN815-6D union, and item [1] 7.) . . .	X	1
2	AN834-6D	Tee	X	1
3	AN820-6	Cap	X	1
4	B330-25	Palnut	X	1
5	D452-6	Nut	X	1
6	D454-6	Retainer (reusable, supersedes MS28773-06)	X	1
7	MS28778-6	Packing (o-ring)	X	1
8	MS17300-056	Stud (Ref)		
9	A141-11	Washer	X	4
10	MS21042L4	Nut	X	4
11	C006	Main Rotor Gearbox Assembly with Hydraulic Pump (Ref, see Figure 63-1)		
12	C215-132	Packing (o-ring)	X	1
13	C117	Shims (Ref)		
14	C267-2	Cartridge (supersedes items 25 and 26)	O	1
15	C215-222	Packing (o-ring)	X	1
16	D205-11	Hose (90° elbow at reservoir end)	X	1
	D205-1*	Hose (straight both ends)	X	1
17	AN834D4	Tee	X	1
18	AN929-4	Cap	X	1
19	B330-21	Palnut	X	1
20	D452-4	Nut	X	1
21	D454-4	Retainer (reusable, supersedes MS28773-04)	X	1
22	MS28778-4	Packing (o-ring)	X	1
23	110-4	Telatemp (temperature recorder, 220° – 270°F)	X	1
24	D500-1	Pump Assembly	X	1
	D500-1R	D500-1 Pump Assembly (overhaul exchange)	X	1
25	C267-1	Cartridge (earlier R44s; Ref)	O	1
26	C256-1	Insulator (used only with item 25; earlier R44s)	X	1

NOTES * Installed on earlier R44s. See also Figure 29-11.

Intentionally Blank

CHAPTER 32

LANDING GEAR

<i>Figure</i>	<i>Title</i>	<i>Page</i>
32-1	Landing Gear Assembly	32.0
32-5	Landing Gear Assembly	32.4
32-9	Strut Fairing Installation	32.8
32-11	Strut Fairing Installation	32.10
32-11B	Landing Gear Lug – Extension Installation	32.11
32-13	Pop-Out Floats – Cylinder Assembly Installation	32.12
32-15	Pop-Out Floats – Cylinder Assembly Installation	32.14
32-17	Pop-Out Floats – Lever Assembly	32.16
32-19	Pop-Out Floats – Tube Assemblies Installation	32.18
32-23	Pop-Out Floats – Tube Assembly Components	32.22
32-25	Pop-Out Floats – Tube Assembly Components	32.24
32-27	Pop-Out Floats – Hoses Installation	32.26
32-29	Fixed Floats – Tube Assemblies Installation	32.28
32-33	Fixed Floats – Components	32.32

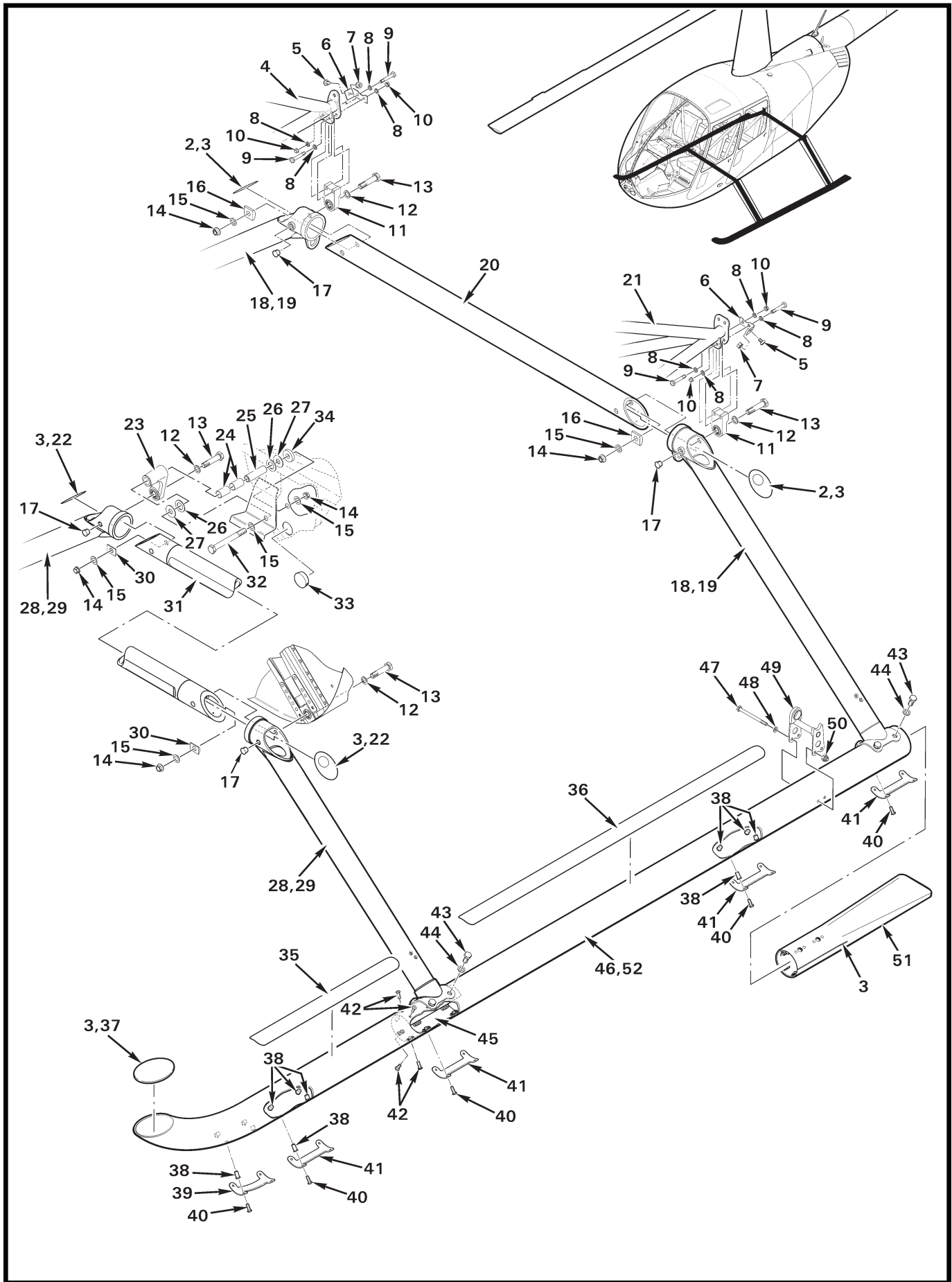

FIGURE AND INDEX NUMBER	PART NUMBER	DESCRIPTION	PARTS AVAIL	QTY PER ASSY
LANDING GEAR ASSEMBLY				
32-1-1	C014-27	Landing Gear Assembly – Standard (Incl items 3, 16, 18, 20, 28, 30, 31, and 37 thru 51)	X	1
	C014-30*	Landing Gear Assembly – Extended (Incl items 3, 16, 19, 20, 29, 30, 31, and 37 thru 51)	X	1
2	C247-3	Cap (clear; bond in place using item 3, window up, painted side against crosstube)	X	2
3	B270-1	Sealant (2-oz tube)	X	A/R
4	C046-2	Lower Frame Assembly – RH (Ref)		
5	S14119	Screw (plastic)	X	2
6	D310-6	Bracket – RH	X	1
	D310-5	Bracket – LH	X	1
7	A31007	Nut (plastic)	X	2
8	A141-11	Washer	X	8
9	NAS6604-17	Bolt	X	4
10	D210-4	Nut	X	4
11	C574-1	Support Assembly	X	2
12	C141-4	Washer	X	2
13	NAS6607P20	Bolt	X	4
14	D210-7	Nut	X	2
15	NAS1149F0732P	Washer	X	2
16	F247-1	Spacer	X	2
17	2633	Hole Plug	X	4
18	C239-12	Strut Assembly – Aft (standard gear)	X	2
19	C239-16*	Strut Assembly – Aft (extended gear)	X	2
20	C241-3	Cross Tube (aft)	X	1
21	C046-23	Lower Frame Assembly – LH (Ref)		
22	F411-9	Cap (clear; bond in place using item 3, window up, painted side against cross tube)	X	2
23	C276-1	Shackle Assembly	X	1
24	LJS-1016	Bearing	X	2
25	C105-1	Journal	X	1
26	A214-10	Washer	X	2
27	C141-5	Washer	X	2
28	C239-13	Strut Assembly – Forward (standard gear)	X	2
29	C239-17*	Strut Assembly – Forward (extended gear)	X	2
30	F247-2	Spacer	X	2

NOTES * Optional; not shown.

Continues

FIGURE AND INDEX NUMBER	PART NUMBER	DESCRIPTION	PARTS AVAIL	QTY PER ASSY
LANDING GEAR ASSEMBLY (Cont'd)				
32-1-31	C241-4	Cross Tube (forward)	X	1
32	NAS6607-52	Bolt	X	1
33	2740	Hole Plug (DP-1250)	X	1
34	C141-6	Washer	X	1
35	A751-4	Strip (forward, 18-inch length)	X	2
36	A751-5	Strip (aft, 38-inch length)	X	2
37	C247-1	Cap (install using item 3)	X	2
38	NAS1330H3K116L	Rivnut	X	24
39	A667-8	Shoe (curved)	X	2
40	A142-1	Screw	X	40
41	A667-7	Shoe (straight)	X	8
42	A142-3	Screw	X	8
43	NAS6606-4	Bolt	X	16
44	NAS1149F0663P	Washer	X	16
45	C246-5	Liner Assembly – LH	X	1
	C242-6	Liner Assembly – RH (not shown)	X	1
46	C242-5	Skid tube – LH	X	1
	C242-6	Skid tube – RH (not shown)	X	1
47	NAS6604-46	Bolt	X	4
48	NAS1149F0432P	Washer	X	4
49	C719-1	Support Assembly (ground wheels)	X	2
50	B340-10	Nut	X	4
51	C937-1	Skid Extension – LH	X	1
	C937-2	Skid Extension – RH (not shown)	X	1
52	C014-11	Skid Tube Assembly – LH (Incl items 3, 37 thru 42, 45 and 46. Does not include item 51.)	X	1
	C014-12	Skid Tube Assembly – RH (Incl items 3, 37 thru 42, 45 and 46. Does not include item 51; not shown.)	X	1

NOTES

Intentionally Blank

FIGURE AND INDEX NUMBER	PART NUMBER	DESCRIPTION	PARTS AVAIL	QTY PER ASSY
		LANDING GEAR ASSEMBLY*		
32-5-1	C014-8	Landing Gear Assembly – Standard (Includes items 2 thru 15, 17, 21, 24 thru 28, 41, and 48 thru 52. Superseded by C014-27; see Figure 32-1.)	O	1
	C014-22**	Landing Gear Assembly – Extended (Includes items 2 thru 17, 24 thru 28, 41, and 47 thru 52. Superseded by C014-30; see Figure 32-1.)	O	1
2	B340-10	Nut	X	4
3	B270-1	Sealant (2-oz tube)	X	A/R
4	C239-2	Strut Assembly – Forward (Standard gear; no longer available. To replace order [2] C239-13 strut assemblies, and [1] C241-4 cross tube and associated hardware. See Figure 32-1.)	O	2
5	C239-1	Strut Assembly – Aft (Standard gear; no longer available. To replace order [2] C239-12 strut assemblies, and [1] C241-3 cross tube and associated hardware. See Figure 32-1.)	O	2
6	C247-1	Rain Cap (install using item 3)	X	2
7	A667-8	Shoe (curved)	X	2
8	A667-7	Shoe (straight)	X	8
9	A142-1	Screw	X	40
10	NAS1330H3K116L	Rivnut	X	24
11	C246-5	Liner Assembly (LH; includes nutplates)	X	1
	C246-6	Liner Assembly (RH; includes nutplates)	X	1
12	NAS1149F0663P	Washer	X	16
13	NAS6606-4	Bolt	X	16
14	C014-11	Skid Tube Assembly (LH; includes C242-5 and items 3, 6 thru 11, and 48)	O	1
	C242-5	Skid Tube	O	1
15	C014-12	Skid Tube Assembly (RH; includes C242-6 and items 3, 6 thru 11, and 48)	O	1
	C242-6	Skid Tube	O	1
16	C239-11**	Strut Assembly – Forward (Extended gear; no longer available. To replace order [2] C239-17 strut assemblies, and [1] C241-4 cross tube and associated hardware. See Figure 32-1.)	O	2
17	C240-1	Elbow	X	4
18	B330-21	Palnut	X	5
19	D210-7	Nut	X	5
20	NAS1149F0763P	Washer	X	8
21	C278-1	Spacer	X	4

NOTES * Earlier R44's.
 ** Optional; not shown.

Continues

FIGURE AND INDEX NUMBER	PART NUMBER	DESCRIPTION	PARTS AVAIL	QTY PER ASSY
LANDING GEAR ASSEMBLY (Cont'd)				
32-5-22	C141-4	Washer	X	8
23	NAS6607-52	Bolt (or NAS6607-54 [aft LH location; Rev. J and prior], if siren installed)	X	5
24	NAS6604-41	Bolt (or NAS6604-43 [aft LH location; Rev. K and prior], if siren installed)	X	4
25	NAS1149F0432P	Washer	X	12
26	D210-4	Nut	X	8
27	C247-2	Rain Cap (install using item 3)	X	4
28	C241-2	Cross Tube (Forward; no longer available. To replace order [1] C241-3 cross tube, and [2] C239-17 (standard) or [2] C239-10 (extended) strut assemblies and associated hardware. See Figure 32-1.)	O	1
29	NAS1149F0732P	Washer	X	2
30	C141-5	Washer	X	2
31	A214-10	Washer	X	2
32	C105-1	Journal	X	1
33	LJS-1016	Bearing	X	2
34	C276-1	Shackle Assembly	X	1
35	C141-6	Washer	X	1
36	C574-1	Support Assembly	X	2
37	A936-2	Wire Assembly	X	1
38	NAS6604-17	Bolt	X	4
39	A141-11	Washer	X	8
40	D310-6	Bracket (RH)	X	1
41	C241-1	Cross Tube (Aft; no longer available. To replace order [1] C241-3 cross tube, and [2] C239-12 (standard) or [2] C239-16 (extended) strut assemblies and associated hardware. See Figure 32-1.)	O	1
42	D310-5	Bracket (LH)	X	1
43	A31007	Nut (plastic)	X	2
44	S14119	Screw (plastic)	X	2
45	2740	Hole Plug (DP-1250)	X	1
46	C015	Cabin Assembly (Ref)		
47	C239-10*	Strut Assembly – Aft (Extended gear; no longer available. To replace order [2] C239-16 strut assemblies, and [1] C241-3 cross tube and associated hardware. See Figure 32-1.)	O	2
48	A142-3	Screw	X	8

NOTES * Optional; not shown.

FIGURE AND INDEX NUMBER	PART NUMBER	DESCRIPTION	PARTS AVAIL	QTY PER ASSY
LANDING GEAR ASSEMBLY (Cont'd)				
32-5-49	NAS6604-46	Bolt	X	4
50	C719-1	Support Assembly (ground wheels)	X	2
51	C937-1	Extension – Skid (LH)	X	1
52	C937-2	Extension – Skid (RH, not shown)	X	1
53	C242-1	Skid Tube (LH, Ref; no longer available)		
	C242-2	Skid Tube (RH, Ref; no longer available)		
54	C246-1	Liner Assembly (Ref; no longer available)		
55	C014-10	Strut Assembly – Forward (Standard gear; for spares. Includes items 3, 4, 17, 21, and 27).	X	2
56	C014-24*	Strut Assembly – Forward (Extended gear; for spares. Includes items 3, 16, 17, 21, and 27.)	X	2
57	C014-9	Strut Assembly – Aft (Standard gear; for spares. Includes items 3, 5, 17, 21, and 27.)	X	2
58	C014-23*	Strut Assembly – Aft (Extended gear; for spares. Includes items 3, 17, 21, 27, and 47.)	X	2

NOTES * Optional; not shown.

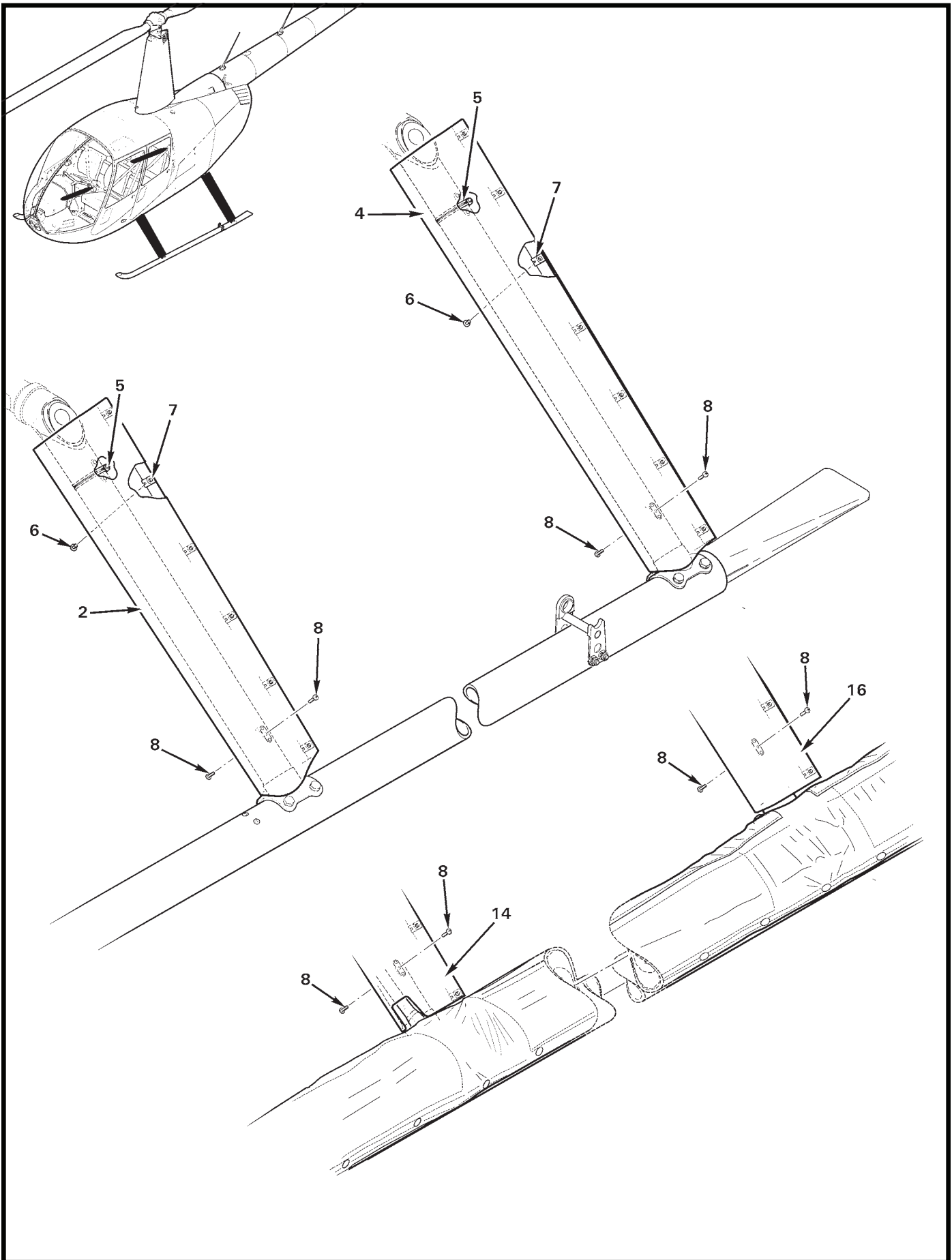

FIGURE AND INDEX NUMBER	PART NUMBER	DESCRIPTION	PARTS AVAIL	QTY PER ASSY
STRUT FAIRING INSTALLATION*				
32-9-1	C082-62.CS**	Fairing Assembly – Forward (RH)	X	1
	C082-32.CS**	Fairing Assembly – Forward (RH)	X	1
2	C082-63.CS	Fairing Assembly – Forward (LH)	X	1
	C082-33.CS	Fairing Assembly – Forward (LH)	X	1
3	C082-64.CS**	Fairing Assembly – Aft (RH)	X	1
	C082-34.CS**	Fairing Assembly – Aft (RH)	X	1
4	C082-65.CS	Fairing Assembly – Aft (LH)	X	1
	C082-35.CS	Fairing Assembly – Aft (LH)	X	1
5	B227-28	Clamp	X	4
6	B526-6*	Screw ([24] required with items 13 thru 16)	X	26
7	B162-3	Clipnut ([24] required with items 13 thru 16)	X	26
8	MS27039C0810	Screw	X	8
* * *				
9	C082-72.CS**	Fairing Assembly – Forward (RH, extended gear)	X	1
	C082-42.CS**	Fairing Assembly – Forward (RH, extended gear)	X	1
10	C082-73.CS**	Fairing Assembly – Forward (LH, extended gear)	X	1
	C082-43.CS**	Fairing Assembly – Forward (LH, extended gear)	X	1
11	C082-74.CS**	Fairing Assembly – Aft (RH, extended gear)	X	1
	C082-44.CS**	Fairing Assembly – Aft (RH, extended gear)	X	1
12	C082-75.CS**	Fairing Assembly – Aft (LH, extended gear)	X	1
	C082-45.CS**	Fairing Assembly – Aft (LH, extended gear)	X	1
* * *				
13	C082-82.CS**	Fairing Assembly – Forward (RH, pop-out float gear)	X	1
	C082-52.CS**	Fairing Assembly – Forward (RH, pop-out float gear)	X	1
14	C082-83.CS	Fairing Assembly – Forward (LH, pop-out float gear)	X	1
	C082-53.CS	Fairing Assembly – Forward (LH, pop-out float gear)	X	1
15	C082-84.CS**	Fairing Assembly – Aft (RH, pop-out float gear)	X	1
	C082-54.CS**	Fairing Assembly – Aft (RH, pop-out float gear)	X	1
16	C082-85.CS	Fairing Assembly – Aft (LH, pop-out float gear)	X	1
	C082-55.CS	Fairing Assembly – Aft (LH, pop-out float gear)	X	1

NOTES * Revision "N" and subsequent fairing assemblies. Installed on C014-27 and -30 landing gear. See Figure 32-1. Will be shipped painted white. Additional charges for color matching.
 ** Not shown.

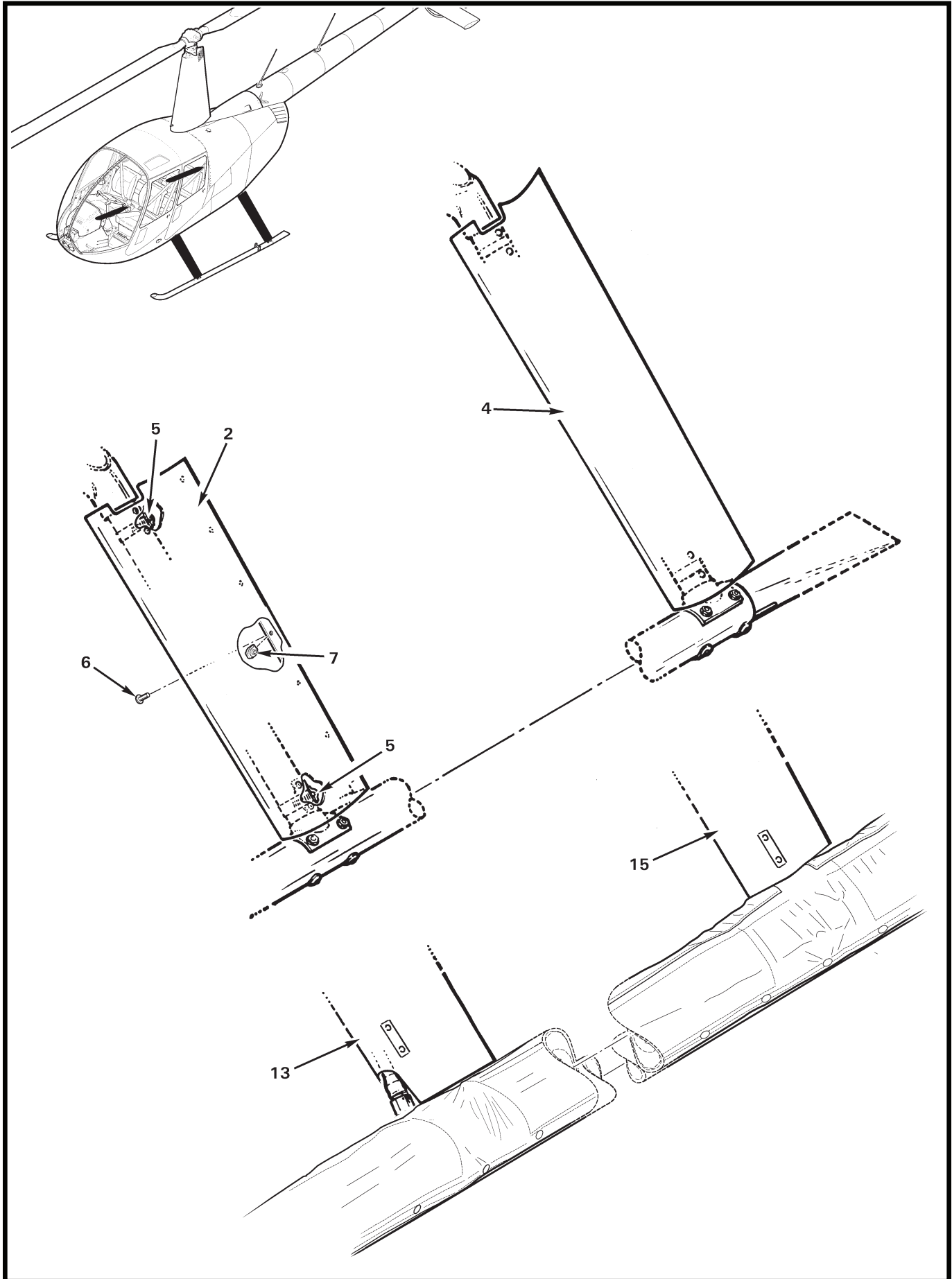

FIGURE AND INDEX NUMBER	PART NUMBER	DESCRIPTION	PARTS AVAIL	QTY PER ASSY
STRUT FAIRING INSTALLATION*				
32-11-1	C082-2.CS**	Fairing Assembly – Forward (RH)	X	1
2	C082-3.CS	Fairing Assembly – Forward (LH)	X	1
3	C082-4.CS**	Fairing Assembly – Aft (RH)	X	1
4	C082-5.CS	Fairing Assembly – Aft (LH)	X	1
5	HTM-200	Clamp	X	8
	B270-10	Adhesive (for clamp threads)	X	A/R
6	MS27039C0805	Screw (B526-6 screw optional)	X	26
7	B162-3	Clipnut	X	26
* * *				
8	C082-12.CS**	Fairing Assembly – Forward (RH, extended gear)	X	1
9	C082-13.CS**	Fairing Assembly – Forward (LH, extended gear)	X	1
10	C082-14.CS**	Fairing Assembly – Aft (RH, extended gear)	X	1
11	C082-15.CS**	Fairing Assembly – Aft (LH, extended gear)	X	1
* * *				
12	C082-22.CS**	Fairing Assembly – Forward (RH, pop-out float gear)	X	1
13	C082-23.CS	Fairing Assembly – Forward (LH, pop-out float gear)	X	1
14	C082-24.CS**	Fairing Assembly – Aft (RH, pop-out float gear)	X	1
15	C082-25.CS	Fairing Assembly – Aft (LH, pop-out float gear)	X	1

NOTES * Revision "M" and prior fairing assemblies. Installed on C014-8 and -22 landing gear. See Figure 32-5. Will be shipped painted white. Additional charge for color matching.
 ** Not shown.

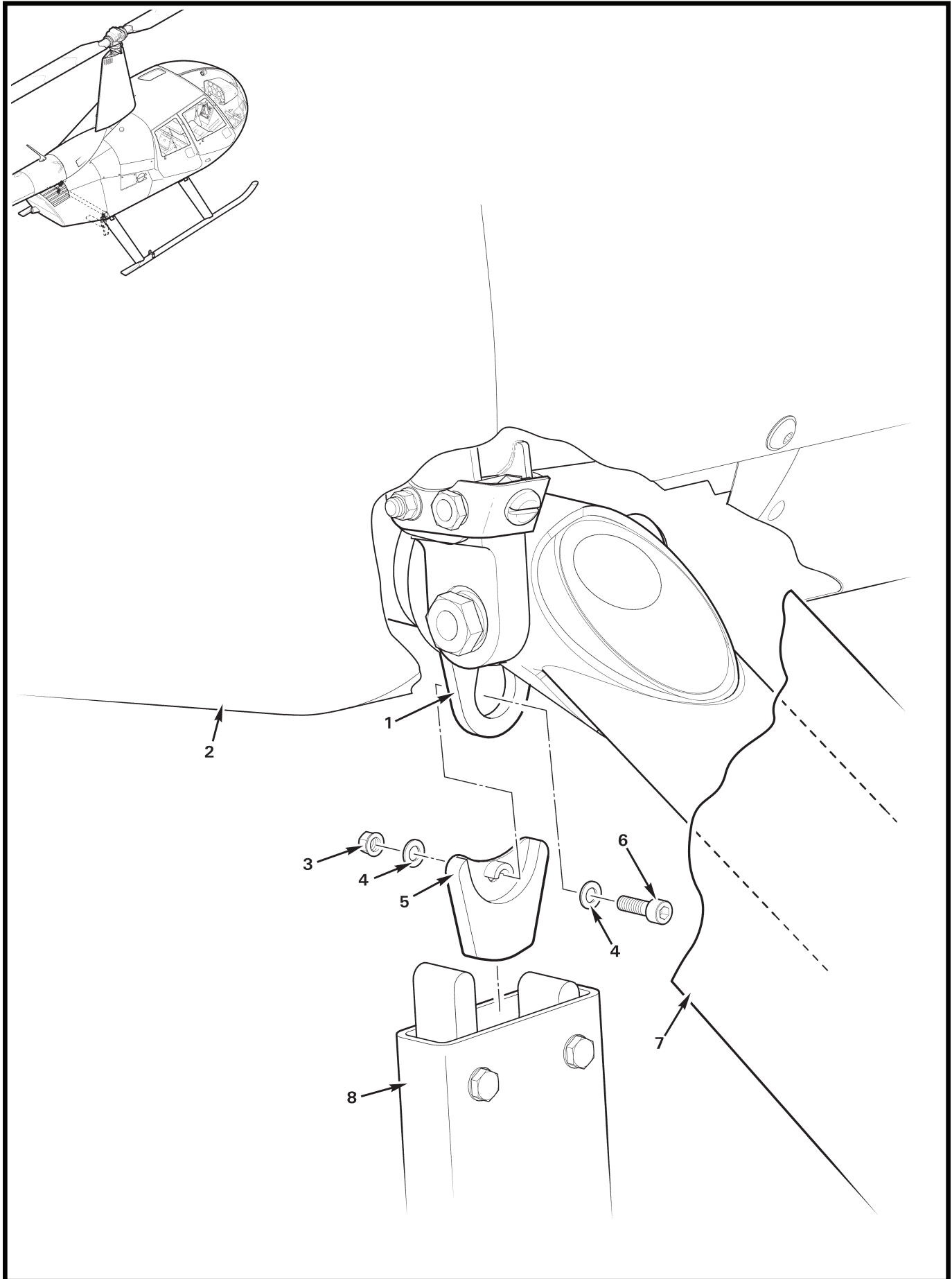

FIGURE AND INDEX NUMBER	PART NUMBER	DESCRIPTION	PARTS AVAIL	QTY PER ASSY
LANDING GEAR LUG – EXTENSION INSTALLATION				
32-11B-1	C239-12	Strut Assembly – Aft (standard gear; Ref, see Figure 32-1)		
	C239-16	Strut Assembly – Aft (Extended gear. Ref, not shown; see Figure 32-1.)		
2	D040-1	Cowling Assembly – Aft (Ref, see Figure 53-5)		
3	D210-3	Nut	X	1
4	NAS620-10L	Washer	X	2
5	F411-10	Extension	X	1
6	NAS1351-3-10P	Screw	X	1
7	C082	Fairing Assembly – Aft (RH, Ref; see Figure 32-9)		
8	—	Tow Cart* (Ref)		
<p>NOTES * Refer to MT950 Ground Handling Cart Operating Instructions, Maintenance Manual, and Illustrated Parts Catalog online at www.robinsonheli.com.</p>				

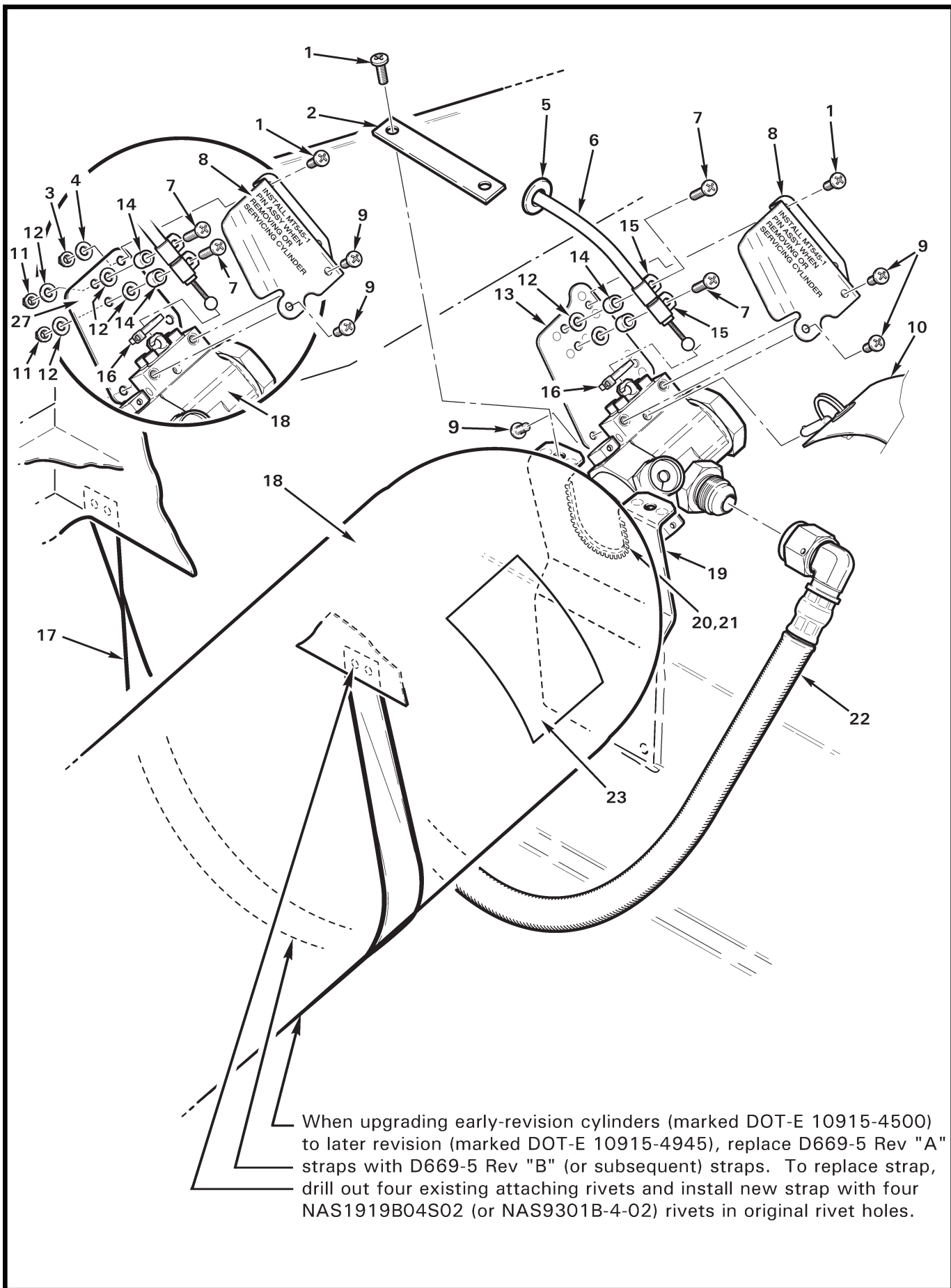
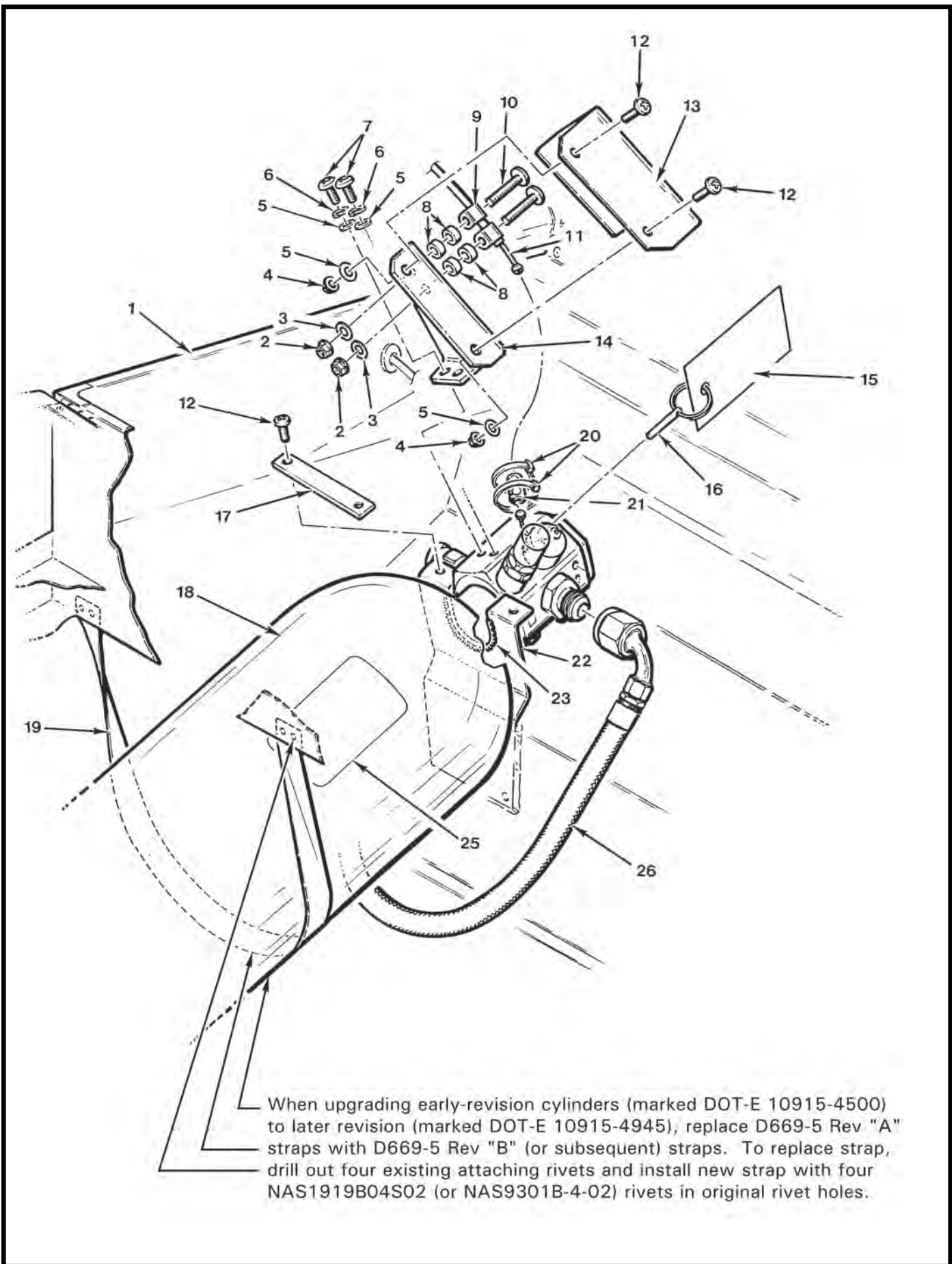

FIGURE AND INDEX NUMBER	PART NUMBER	DESCRIPTION	PARTS AVAIL	QTY PER ASSY
		POP-OUT FLOATS – CYLINDER ASSEMBLY INSTALLATION		
32-13-1	MS27039C0806	Screw	X	4
2	D669-3	Strap	X	1
3	MS21042L08	Nut	X	2
4	NAS1149FN816P	Washer	X	2
5	MS35489-6	Grommet	X	1
6	D676-1	Cable (Ref, see Figure 32-17)		
7	MS27039C1-12	Screw	X	2
8	D761-2	Cover	X	1
9	MS27039C0805	Screw	X	4
10	MT545-1	Pin Assembly	X	1
11	MS21042L3	Nut (for earlier R44s)	X	2
12	NAS1149F0332P	Washer ([4] required on earlier R44s when item 11 is installed) . .	X	2
13	D761-1	Support Assembly (revision "C" and higher)	X	1
14	C130-26	Spacer	X	2
15	AN735-3	Clamp	X	2
16	MS3367-4-9	Ty-Rap	X	1
17	D669-5	Strap (Ref)		
18	D679-3*	Cylinder Assembly (filled)	X	1
	D679-3R*	D679-3 Cylinder Assembly (filled; overhaul exchange)	X	1
	D679-4*	Cylinder Assembly (empty)	X	1
	D679-4R*	D679-4 Cylinder Assembly (empty; overhaul exchange)	X	1
19	D669-1	Cradle Assembly (Ref)		
20	MS21266-1N	Grommet (install using item 24)	X	A/R
21	B270-8qt	Adhesive	X	A/R
22	D674-1	Hose	X	1
23	D682-6	Decal (cylinder pressure limits)	X	1
		* * *		
24	MT546-2**	Adapter Assembly – Filler (includes MS28778-2 packing)	X	1
	MS28778-2**	Packing	X	1
25	KI-151**	Pop-Out Float Cylinder Bleed-Off Kit	X	1
26	KI-175	Cylinder Replacement Installation Kit (Incl items 1, 3, 4, 7 thru 9, and 12 thru 16; not shown)	X	1

NOTES * When replacing D679-1 Cylinder Assembly, also order KI-175 installation kit.
 ** Not shown; see Figure 99-21.



When upgrading early-revision cylinders (marked DOT-E 10915-4500) to later revision (marked DOT-E 10915-4945), replace D669-5 Rev "A" straps with D669-5 Rev "B" (or subsequent) straps. To replace strap, drill out four existing attaching rivets and install new strap with four NAS1919B04S02 (or NAS9301B-4-02) rivets in original rivet holes.

FIGURE AND INDEX NUMBER	PART NUMBER	DESCRIPTION	PARTS AVAIL	QTY PER ASSY
		POP-OUT FLOATS – CYLINDER ASSEMBLY INSTALLATION		
32-15-1	—	Seat Frame – Pilot (Ref)		
2	MS21042L3	Nut	X	2
3	NAS1149F0332P	Washer	X	2
4	MS21042L08	Nut	X	2
5	NAS1149FN832P	Washer	X	4
6	B332-42	Lockwasher	X	2
7	MS27039C0805	Screw	X	2
8	A130-20	Spacer	X	4
9	AN735-3	Clamp	X	2
10	MS27039C1-11	Screw	X	2
11	D676-1	Cable (Ref, see Figure 32-17)	X	1
12	MS27039C0806	Screw	X	2
13	D675-9*	Cover (Ref)		
14	D675-10*	Support (Ref)		
15	—	Placard	O	1
16	—	Locking Pin	O	1
17	D669-3	Strap	X	1
18	D679-1*	Cylinder Assembly (Ref; to replace refer to Figure 32-13)		
19	D669-5	Strap (Ref)		
20	MS3367-4-9	Ty-Rap	X	2
21	B125-2	Connector	X	1
22	D669-1	Cradle Assembly (Ref)		
23	MS21266-1N	Grommet (install using item 24)	X	A/R
24	B270-8qt	Adhesive	X	A/R
25	D682-1	Decal (cylinder pressure limits)	X	1
26	D674-1	Hose	X	1

NOTES * No longer available. To replace order KI-175 installation kit. See Figure 32-13.

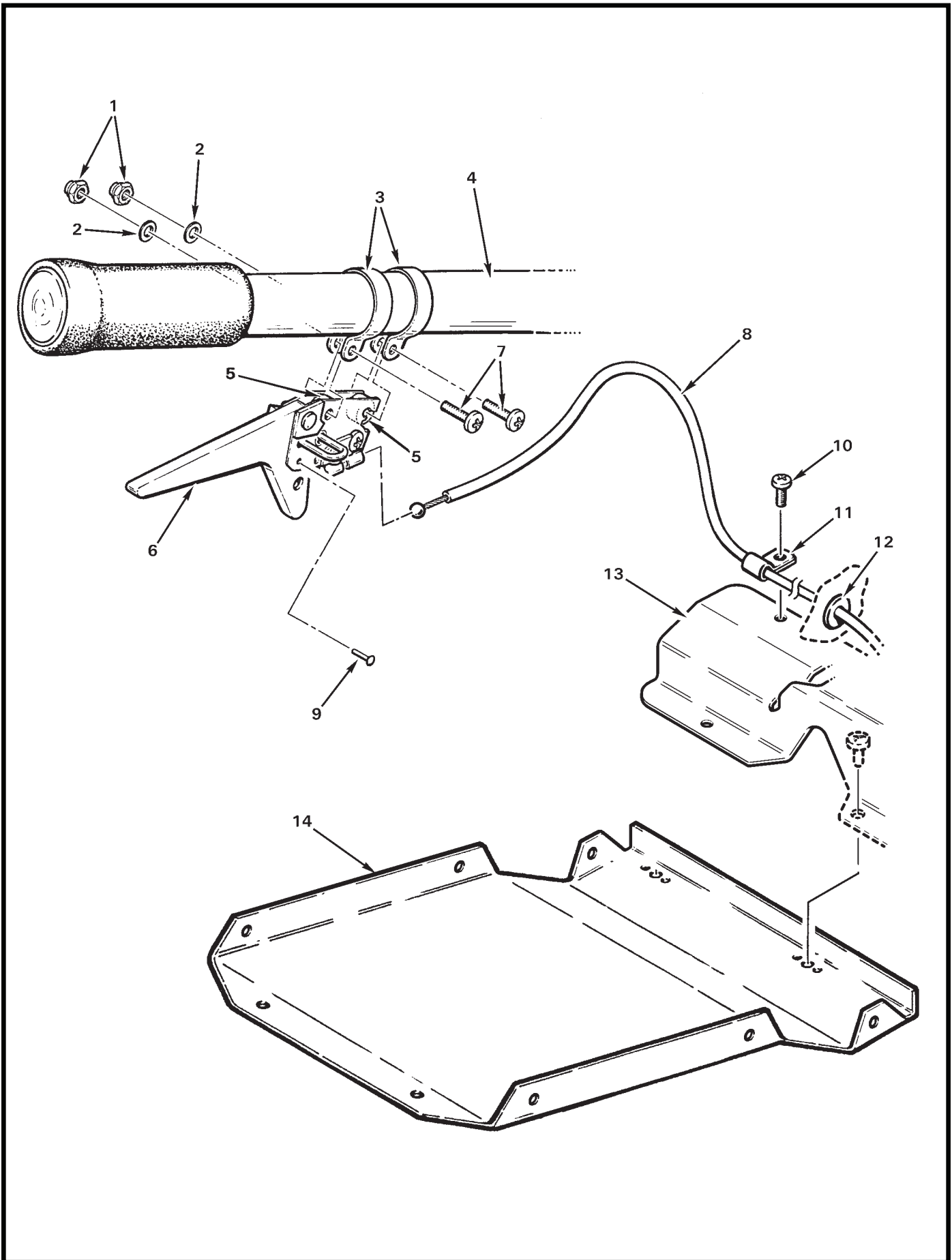

FIGURE AND INDEX NUMBER	PART NUMBER	DESCRIPTION	PARTS AVAIL	QTY PER ASSY
POP-OUT FLOATS – LEVER ASSEMBLY				
32-17-1	B340-8	Nut	X	2
2	NAS620-10L	Washer	X	2
3	D675-4	Clamp	X	2
4	C758-1	Collective Stick Assembly – Pilot (RH, Ref; see Figure 67-21 for complete assembly)		
5	A130-21	Spacer (between plates as shown)	X	2
6	D680-1	Lever Assembly (Incl items 1 thru 3, 5, and 7)	X	1
7	MS27039C1-09	Screw	X	2
8	D676-1	Cable	X	1
9	MS20470A2-6.5S	Rivet (shear)	X	1
10	MS27039C0806	Screw (Ref)		
11	AN742-3	Clamp	X	1
12	MS35489-6	Grommet	X	1
13	C445-3	Cover (Ref, see Figure 6-5)		
14	D672-1	Cover	X	1

NOTES

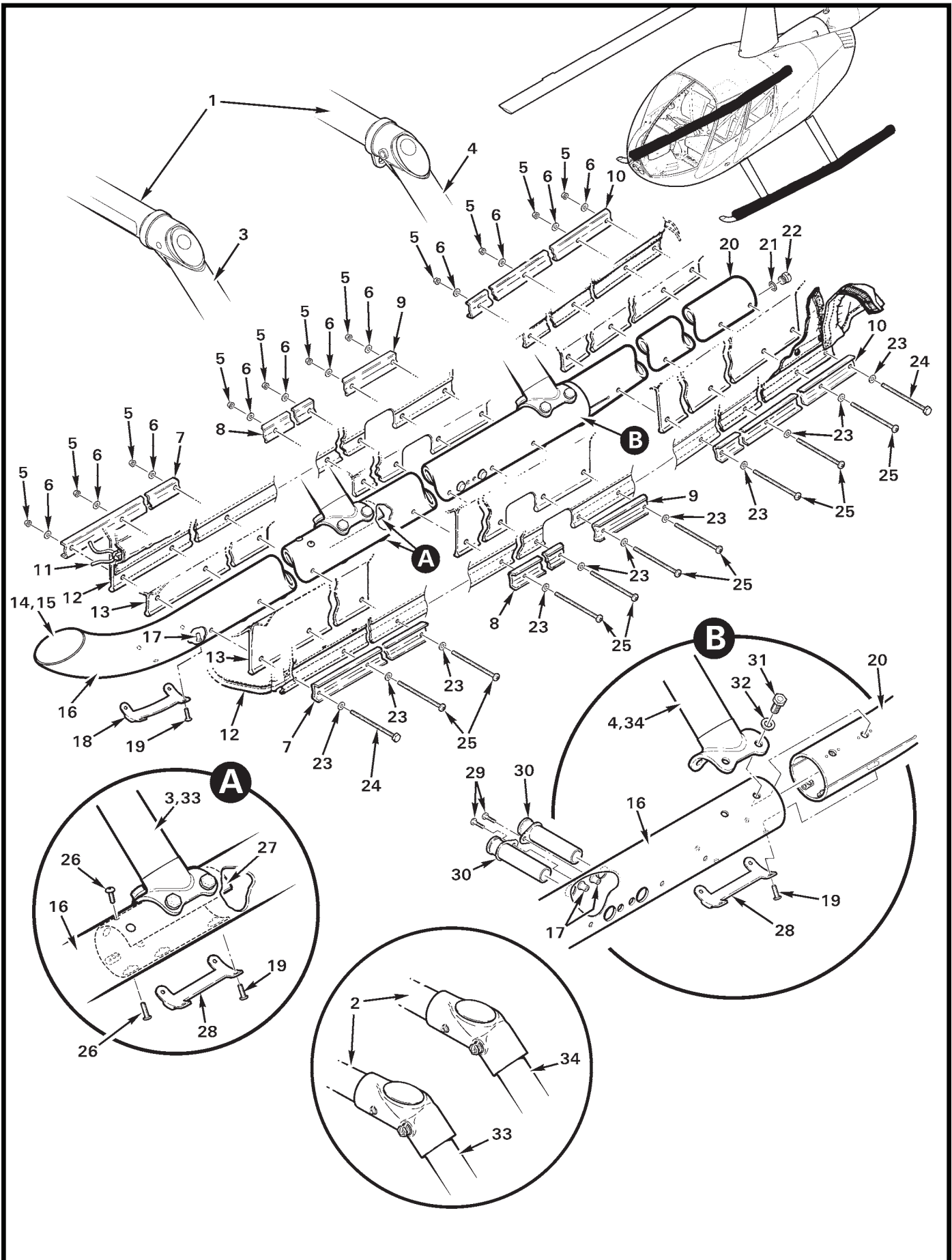

FIGURE AND INDEX NUMBER	PART NUMBER	DESCRIPTION	PARTS AVAIL	QTY PER ASSY
POP-OUT FLOATS – TUBE ASSEMBLIES INSTALLATION				
32-19-1	C014-28	Landing Gear Assembly – Pop-Out Floats (Incl items 3, 4, 14, thru 20, and 26 thru 32)	X	1
2	C014-22*	Landing Gear Assembly – Pop-Out Floats (Incl items 14 thru 20, and 26 thru 34)	O	1
3	C239-17	Strut Assembly – Forward (Ref)		
4	C239-16	Strut Assembly – Aft (Ref)		
5	MS21042L3	Nut (install using item 15)	X	62
6	NAS1149F0332P	Washer (or NAS1149F0363P)	X	62
7	C944-1	Strip	X	4
8	C944-4	Strip	X	4
9	C944-5	Strip	X	4
10	C944-3	Strip	X	4
11	M11029	Cord	X	1
12	C950-25	Cover (LH; ACC Float. Includes item 11.)	X	1
	C950-25.CS	Cover (LH; ACC, SMR Float [spares]. Includes item 11.)	X	1
	C950-26	Cover (RH, ACC Float. Includes item 11.)	X	1
	C950-26.CS	Cover (RH; ACC, SMR Float [spares]. Includes item 11.)	X	1
13	C950-19 or -23	Float Assembly – LH (Ref, see Figure 32-23)		
	C950-20 or -24	Float Assembly – RH (Ref, see Figure 32-23; not shown)		
14	C247-1	Rain Cap (install using item 15)	X	1
15	B270-1*	Sealant (2-oz tube)	X	A/R
16	C014-25	Skid Tube Assembly (LH; includes items 14, 15, 17 thru 19, and 26 thru 30; does not include item 20)	X	1
	C014-26	Skid Tube Assembly (RH; includes items 14, 15, 17 thru 19, and 26 thru 30; does not include item 20)	X	1
17	NAS1330H3K116L	Rivnut	X	14
18	A667-8	Skid Shoe (curved)	X	1
19	A142-1	Screw	X	20
20	C945-1	Skid Extension (LH)	X	1
	C945-2	Skid Extension (RH, not shown)	X	1
21	A215-013	O-Ring	X	1
22	B202-1	Drain Plug Assembly (Incl item 24)	X	1
23	NAS1149F0332P**	Washer (or NAS1149F0363P)	X	A/R
24	AN3-32A	Bolt (or MS27039DD1-47 or -51 as required to expose 2 to 4 threads; install using item 15)	X	4

NOTES * See also Figure 32-5.
 ** See R44 Maintenance Manual §5.620 for location and usage.

Continues

FIGURE AND INDEX NUMBER	PART NUMBER	DESCRIPTION	PARTS AVAIL	QTY PER ASSY
POP-OUT FLOATS – TUBE ASSEMBLIES INSTALLATION (Cont'd)				
32-19-25	MS27039DD1-51	Screw (or MS27039DD1-47 or AN3-32A Bolt [not shown] as required to expose 2 to 4 threads; install using item 15)	X	58
26	A142-3	Screw	X	4
27	C246-5	Liner Assembly (left skid)	X	1
	C246-6	Liner Assembly (right skid)	X	1
28	A667-7	Skid Shoe (straight)	X	4
29	MS27039C1-09	Screw	X	2
30	D724-1	Sleeve Weldment (2 per skid)	X	4
31	NAS6604-4	Bolt	X	16
32	NAS1149F0663P	Washer	X	16
33	C239-11**	Strut Assembly – Forward (LH and RH)	X	2
34	C239-10**	Strut Assembly – Aft (LH and RH)	X	2

NOTES * Install using item 15.
 ** For earlier R44s see also Figure 32-5.

Intentionally Blank

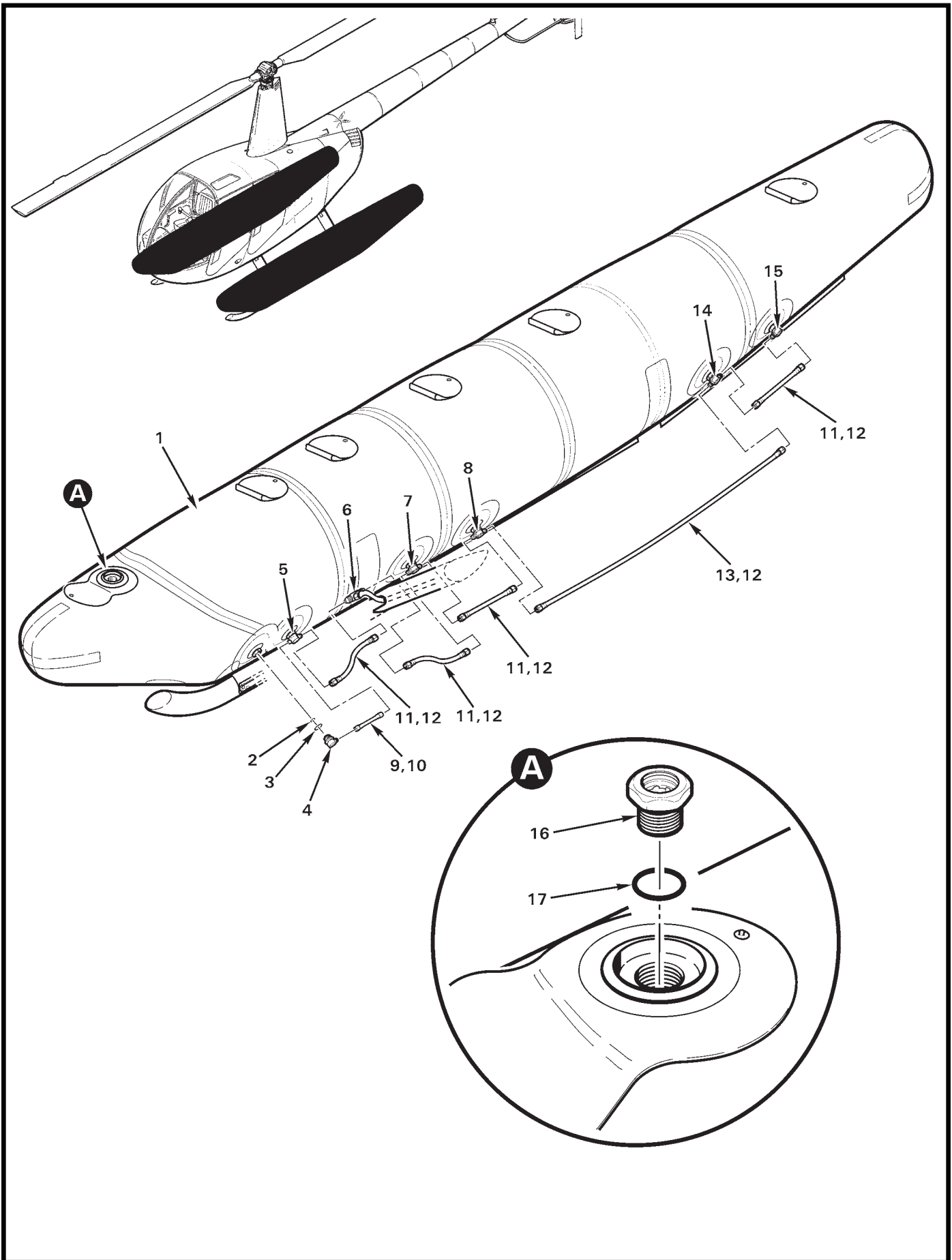

FIGURE AND INDEX NUMBER	PART NUMBER	DESCRIPTION	PARTS AVAIL	QTY PER ASSY
		POP-OUT FLOATS – TUBE ASSEMBLY COMPONENTS*		
32-23-1	C950-24	Float Tube Assembly – RH (Six-chamber; includes items 16; Air Cruisers, [Mfg])	X	1
	C950-20	Float Tube Assembly – RH (Six-chamber; includes items 16; SMR Technologies, Inc. [Mfg]; not shown)	X	1
	C950-23	Float Tube Assembly – LH (Six-chamber; includes items 16; Air Cruisers, [Mfg.]; not shown)	X	1
	C950-19	Float Tube Assembly – LH (Six-chamber, includes items 16; SMR Technologies, Inc. [Mfg]; not shown)	X	1
2	A215-110	O-Ring	X	1
3	A215-212	O-Ring	X	1
4	D770-1	Valve Assembly (Incl items 2 and 3)	X	1
5	D770-2	Valve Assembly (Incl items 2 and 3)	X	1
6	AN824-8D	Tee (Ref, see Figure 32-21)		
7	D770-3	Valve Assembly (Incl items 2 and 3)	X	1
8	D770-4	Valve Assembly (Incl items 2 and 3)	X	1
9	D674-7	Hose Assembly (Incl item 10)	X	1
10	B158-12	Heat Shrink	X	A/R
11	D674-6	Hose Assembly (Incl item 12)	X	1
12	B158-16	Heat Shrink	X	A/R
13	D674-2	Hose Assembly (Incl item 12)	X	1
14	D770-5	Valve Assembly (Incl items 2 and 3)	X	1
15	D770-6	Valve Assembly (Incl items 2 and 3)	X	1
16	A-53001	Valve – Pressure Topping and Relief (Incl item 17)	X	6
17	A215-212	O-Ring	X	1
18	KI-83-3**	Pop-Out Float Repair Kit (SMR floats)	X	1
19	KI-83-4**	Pop-Out Float Repair Kit (ACC floats)	X	1

NOTES * Six-chamber floats.
 ** Not shown.

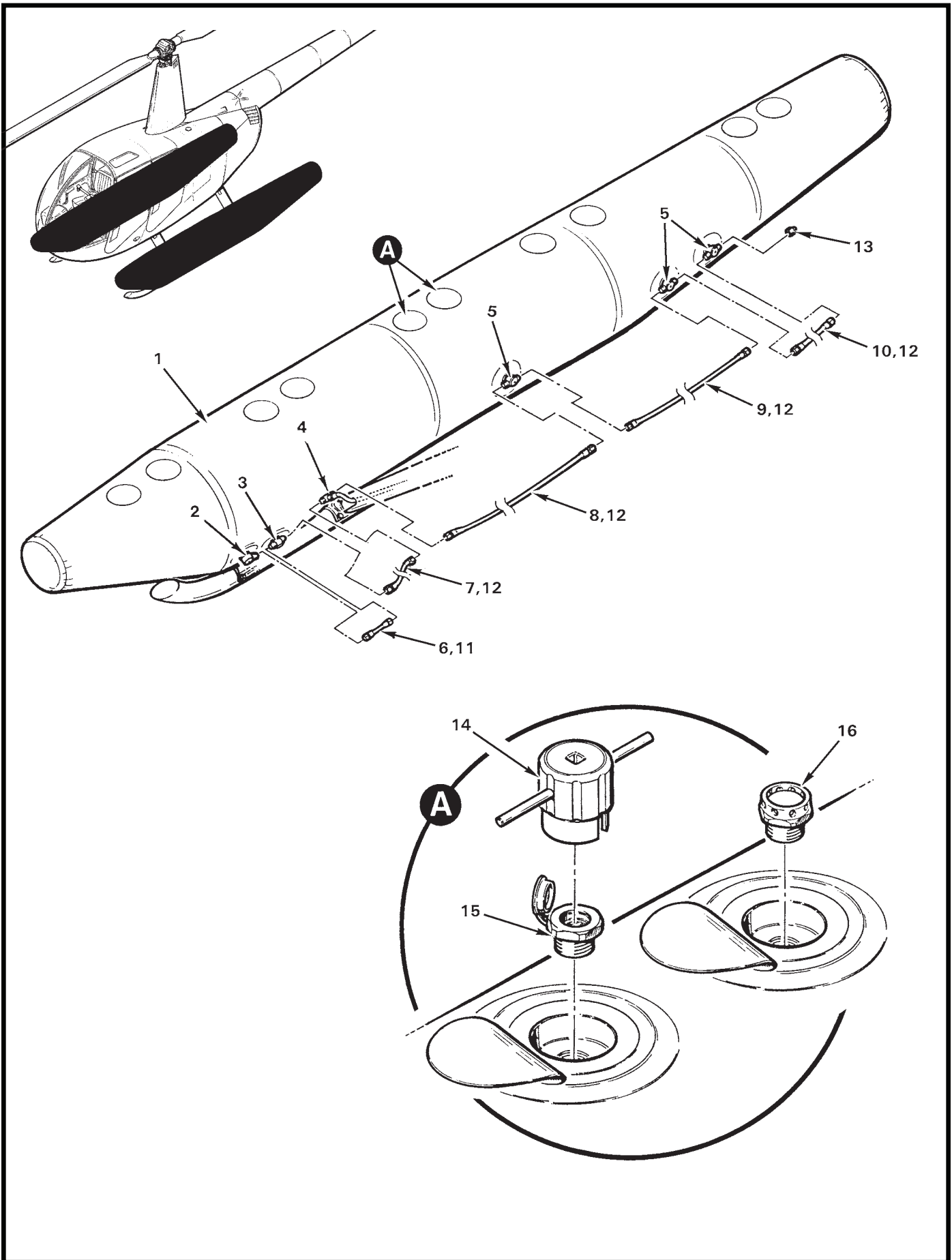

FIGURE AND INDEX NUMBER	PART NUMBER	DESCRIPTION	PARTS AVAIL	QTY PER ASSY
POP-OUT FLOATS – TUBE ASSEMBLY COMPONENTS*				
32-25-1	C950-2	Float Tube Assembly – RH (Incl items 2, 3, 5, 13, 15, and 16) . .	O	1
	C950-1	Float Tube Assembly – LH (Incl items 2, 3, 5, 13, 15, and 16; not shown)	O	1
2	20525**	Inlet Check Valve (Ref)	O	1
3	20325**	Inlet Check Valve (Ref)	O	1
4	AN824-8D	Tee	X	2
5	20246**	Inlet Check Valve (Ref)	O	3
6	D674-7	Hose Assembly – LH and RH (Incl item 11)	X	1
7	D674-6	Hose Assembly – LH and RH (Incl item 12)	X	2
8	D674-5	Hose Assembly – LH and RH (Incl item 12)	X	2
9	D674-4	Hose Assembly – LH and RH (Incl item 12)	X	2
10	D674-3	Hose Assembly – LH and RH (Incl item 12)	X	2
11	B158-12	Heat Shrink (black, 0.75 in. dia.)	X	A/R
12	B158-16	Heat Shrink (black, 1.00 in. dia.)	X	A/R
13	AN929-8	Cap	X	1
14	B-51025**	Wrench	O	1
15	B-51209**	Valve – Top-Off	O	5
16	B-51019-4**	Valve – Pressure Relief	O	5
17	KI-83-4	Pop-Out Float Repair Kit	X	1

NOTES * Five-chamber floats.
 ** Apical Industries, Inc. part no.

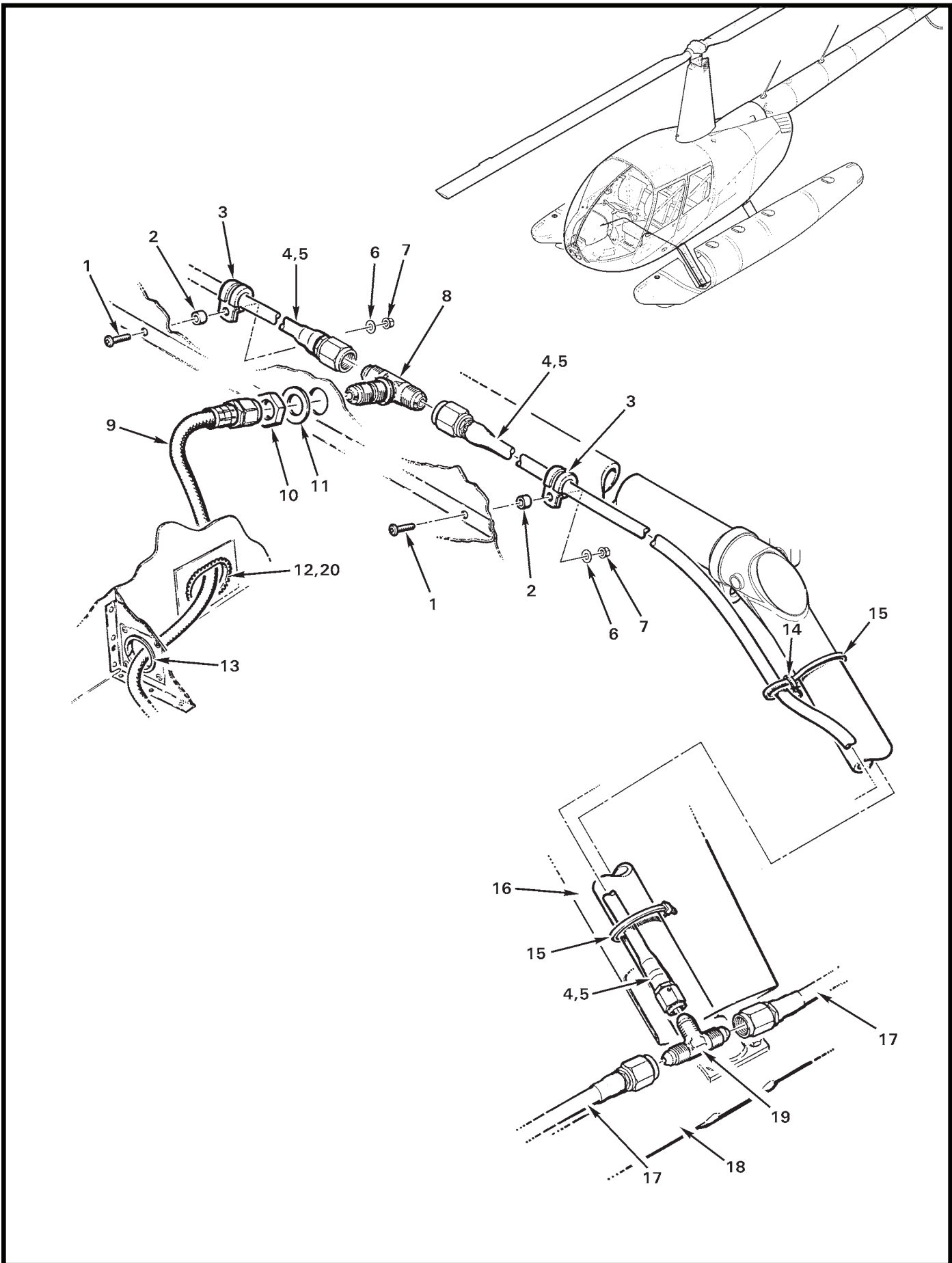

FIGURE AND INDEX NUMBER	PART NUMBER	DESCRIPTION	PARTS AVAIL	QTY PER ASSY
POP-OUT FLOATS – HOSES INSTALLATION*				
32-27-1	MS27039C1-12	Screw	X	2
2	C130-26	Spacer	X	2
3	MS21919WDG10	Clamp	X	2
4	D674-2	Hose Assembly (Incl item 5)	X	2
5	B158-16	Heat Shrink (black, 1.00 in. dia.)	X	A/R
6	NAS1149F0332P	Washer	X	2
7	MS21042L3	Nut	X	2
8	AN834-8D	Tee	X	1
9	D674-1	Hose (from cylinder assembly; see also Figure 32-13)	X	1
10	AN924-8D	Nut	X	1
11	NAS1149F1290P	Washer	X	1
12	MS21266-1N	Grommet (install using item 20)	X	A/R
13	MS35489-20	Grommet	X	1
14	MS3367-5-9	Ty-Rap (or MS3367-7-9; used as a spacer at this location, LH and RH)	X	2
15	MS3367-7-9	Ty-Rap	X	A/R
16	C082-53	Fairing Assembly (Ref, forward LH; see Figure 32-9)		
17	D674-6	Line Assembly (see also Figure 32-23)	X	1
18	C014-25	Skid Tube Assembly – (LH, Ref)		
19	AN824-8D	Tee (LH and RH)	X	2
20	B270-8qt	Adhesive	X	A/R

NOTES * C014-28 landing gear shown. C014-17 landing gear hose installation is identical.

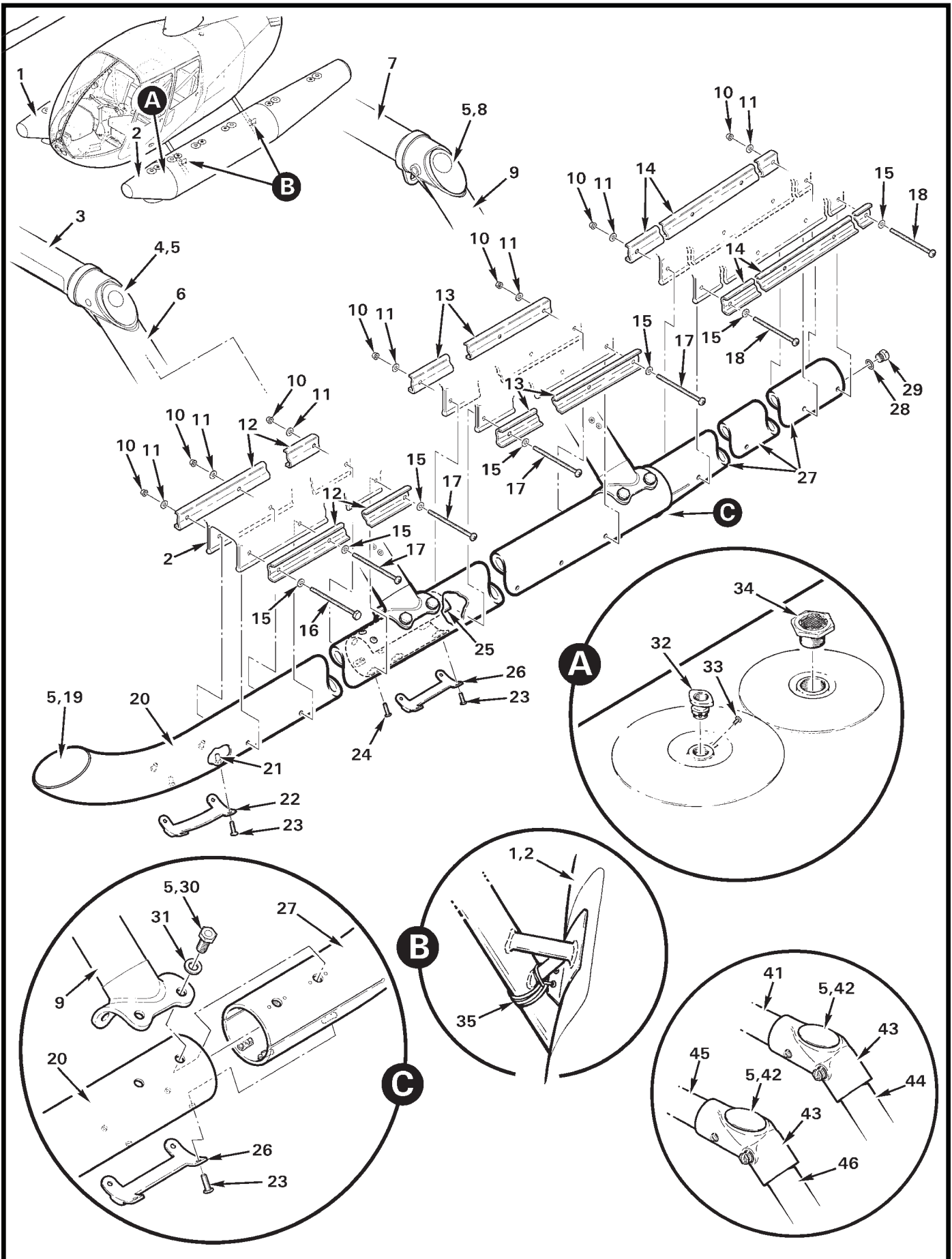

FIGURE AND INDEX NUMBER	PART NUMBER	DESCRIPTION	PARTS AVAIL	QTY PER ASSY
FIXED FLOATS – TUBE ASSEMBLIES INSTALLATION				
32-29-1	B900-7R	Float Tube Assembly* – RH (C949-4, includes items 32 thru 35; painted)	X	1
2	B900-7L	Float Tube Assembly* – LH (C949-3, includes items 32 thru 35; painted)	X	1
3	C241-4*	Cross Tube – Forward (Ref)		
4	F411-9	Cap – Forward (Ref)		
5	B270-1	Sealant (2-oz tube)	X	A/R
6	C239-15	Strut Assembly – Forward (Ref)		
7	C241-3	Cross Tube – Aft (Ref)		
8	C247-3	Cap – Aft (Ref)		
9	C239-14	Strut Assembly – Aft (Ref)	X	1
10	MS21042L3**	Nut	X	31
11	NAS1149F0332P	Washer (or NAS1149F0363P)	X	31
12	C944-1	Strip (LH and RH)	X	2
13	C944-2	Strip (LH and RH)	X	2
14	C944-3	Strip (LH and RH)	X	2
15	NAS1149F0332P	Washer (or NAS1149F0363P)	X	A/R
16	AN3-32A	Bolt (or MS27039DD1-47 or 51 screw)	X	2
17	MS27039DD1-51**	Bolt (or MS27039DD1-47, or AN3-32A bolt; forward and middle girts)	X	20
18	MS27039DD1-47**	Bolt (or MS27039DD1-47, or AN3-32A bolt; aft girts)	X	11
19	C247-1	Rain Cap (install using item 5)	X	1
20	C014-15	Skid Tube Assembly LH (Incl items 5, 19, and 21 thru 26)	X	1
	C014-16	Skid Tube Assembly (RH, Incl items 5, 19, and 21 thru 26)	X	1
21	NAS1330H3K116L	Rivnut	X	12
22	A667-8	Skid Shoe (curved)	X	1
23	A142-1	Screw	X	20
24	A142-3	Screw	X	4
25	C246-5	Liner Assembly (left skid)	X	1
	C246-6	Liner Assembly (right skid, not shown)	X	1
26	A667-7	Skid Shoe (straight)	X	4
27	C945-1	Skid Extension (LH)	X	1
	C945-2	Skid Extension (RH, not shown)	X	1
28	A215-013	O-Ring	X	1
29	B202-1	Drain Plug Assembly (Incl item 28)	X	1
30	NAS6606-4	Bolt (install using item 5)	X	8

NOTES * See Figure 99-25 for shipping crate.
 ** Install using item 5.

Continues

FIGURE AND INDEX NUMBER	PART NUMBER	DESCRIPTION	PARTS AVAIL	QTY PER ASSY
FIXED FLOATS – TUBE ASSEMBLIES INSTALLATION (Cont'd)				
32-29-31	NAS1149F0663P	Washer	X	8
32	4RA1190-2	Hand Pump Fitting (Incl item 33)	X	6
33	—	Screw	X	6
34	3MA1009-4	Pressure Relief Valve	X	6
35	M11029	Lacing (parachute cord)	O	2
36	C014-18A	Landing Gear Assembly with Floats (Incl items 1, 2, 5, 10 thru 18, 29, and 38)	X	1
37	B900-7	Float Assembly Set – Utility (Incl items 1 and 2)	X	1
38	C014-29*	Landing Gear Assembly – Utility Floats (Ref; includes items 3, 5 thru 7, 9, 19 thru 27, 30, and 31. See also Figure 32-1.) . . .	X	1
39	MT340-1	Float Gauge and Fill Gun Kit (not shown)	X	1
40	KI-83-1	Float Repair Kit (not shown)	X	1
* * *				
41	C241-1**	Cross Tube – Aft (Ref)		
42	C247-2**	Rain Cap (install using item 5)	X	4
43	C240-1**	Elbow (Ref)		
44	C014-20**	Strut Assembly – Aft (includes elbow and rain cap)	X	1
45	C241-2**	Cross Tube – Forward (Ref)		
46	C014-21	Strut Assembly – Forward (includes elbow and rain cap)	X	1

NOTES * See Figure 99-25 for shipping crate.
 ** For earlier R44s with C014-19 landing gear assembly installed. See Figure 32-5.

Intentionally Blank

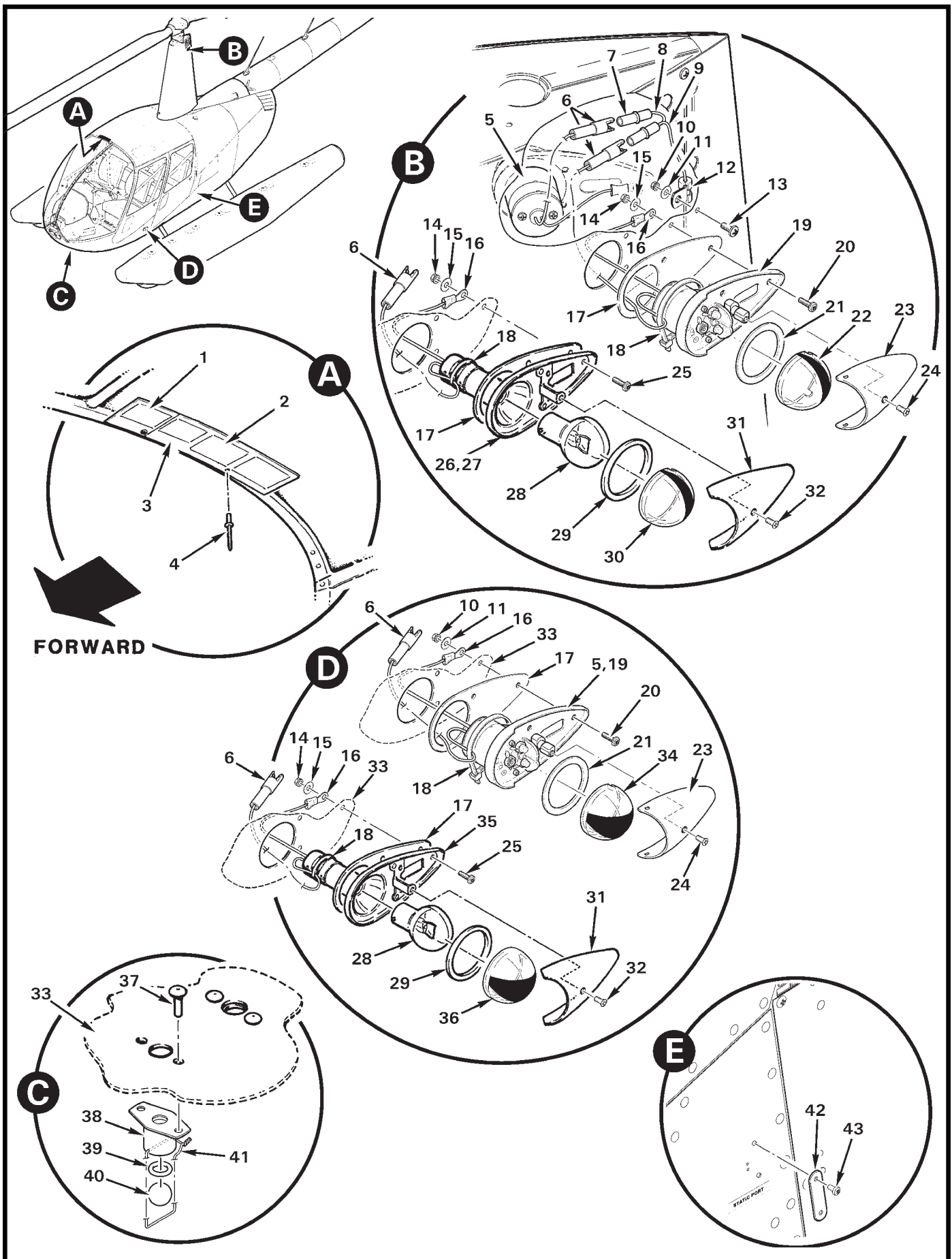

FIGURE AND INDEX NUMBER	PART NUMBER	DESCRIPTION	PARTS AVAIL	QTY PER ASSY
FIXED FLOATS – COMPONENTS				
32-33-1	PAI-DE-CARD	Compass Deviation Placard (Ref, for use with vertical card compass. See also Figure 95-23.)		
2	C654-25	Decal – Flight Limitations (ship S/N 0001 thru 9999, utility floats)	X	1
	D682-15	Decal – Flight Limitations (ship S/N 10001 and higher, utility floats)	X	1
3	A725-4	Mount	X	1
4	B204-1	Rivet (blind; Avdel part no. 1693-0410)	X	2
5	A039-22	Aux Position Light Assembly – RH (Green LED, 14V; includes items 6, 16, and 21 thru 24)	X	1
	A039-20	Aux Position Light Assembly – RH (Green LED, 28V; includes items 6, 16, and 21 thru 24)	X	1
6	B263-10	Housing (one to each light assembly, one at base of mast fairing)	X	3
	B263-1	Pin	X	3
7	B263-11	Housing (one at each light assembly, one at base of mast fairing)	X	3
	B263-2	Socket	X	3
8	-485	Wire (Ref; jumper)		
9	-486	Wire (Ref)		
10	MS21042L08	Nut	X	5
11	NAS1149FN816P	Washer	X	5
12	MS21919WDG2	Clamp (secures wire to mast fairing)	X	5
13	MS27039C0806	Screw	X	5
14	MS21042L06	Nut	X	3
15	NAS1149FN616P	Washer	X	3
16	B260-2	Terminal	X	1
17	A779-1	Gasket	X	1
18	MS3367-4-9	Ty-Rap	X	A/R
19	A039-21	Aux Position Light Assembly – LH (Red LED, 14V; includes items 6, 16, and 21 thru 24)	X	1
	A039-19	Aux Position Light Assembly – LH (Red LED, 28V; includes items 6, 16, and 21 thru 24)	X	1
20	MS35206-230	Screw	X	3
21	38-0230021-00*	Gasket	O	1
22	D369-7	Lens (clear/shaded)	X	2
23	19-150002-010*	Retainer	O	1

NOTES * Whelen part no.

Continues

FIGURE AND INDEX NUMBER	PART NUMBER	DESCRIPTION	PARTS AVAIL	QTY PER ASSY
FIXED FLOATS – COMPONENTS (Cont'd)				
32-33-24	14-0050508-27	Screw	O	1
25	MS24693-S27	Screw	X	3
26	A039-13	Aux Position Light Assembly – LH (red lens, incandescent, no longer available; to replace order items 19 and 22)	X	1
27	A039-12	Aux Position Light Assembly – RH (green lens, incandescent, no longer available; to replace order items 5 and 22)	X	1
28	W1290-14*	Lamp (14-volt)	X	1
	W1290-28*	Lamp (28-volt)	X	1
29	A455*	Gasket	X	1
30	D369-3	Lens – LH (red/shaded)	X	1
	D369-4	Lens – RH (green/shaded, not shown)	X	1
31	W1282*	Lens Retainer	X	1
32	—	Screw	O	1
33	C272-1	Chin (Ref)		
34	D369-5	Lens – LH (clear/shaded)	X	1
	D369-6	Lens – RH (clear/shaded; not shown)	X	1
35	A039-4	Position Light Assembly – LH (Ref, no longer available. To replace order items 19 and 22.)		
	A039-5	Position Light Assembly – RH (Ref, no longer available. To replace order items 5 and 22.)		
36	D369-1	Lens – LH (red/shaded)	X	1
	D369-2	Lens – RH (green/shaded, not shown)	X	1
37	MS20470AD3	Rivet	X	4
38	D371-4	Drain Valve Assembly (includes items 39 thru 41; install using item 44)	X	2
39	A215-010	O-Ring	X	1
40	B208-10	Ball	X	1
41	MS20995C32	0.032 in. dia. Safety Wire	X	A/R
42	D372-2	Air Dam	X	2
43	MS35206-213	Screw	X	4
44	B270-1	Sealant	X	A/R

NOTES * Whelen part no.

CHAPTER 33

LIGHTS

<i>Figure</i>	<i>Title</i>	<i>Page</i>
33-1	Strobe Light Installation (LED)	33.0
33-3	Strobe Light Installation	33.2
33-5	Navigation Lights Installation – Right and Left Position	33.4
33-7	Navigation Lights Installation – Tail Position	33.6
33-11	Landing Lights Installation (HID)	33.10
33-13	Landing Lights Installation	33.12
33-15	Spotlight Installation (LED)	33.14
33-17	Spotlight Installation	33.16
33-19	Cabin Interior Lighting Installation	33.18

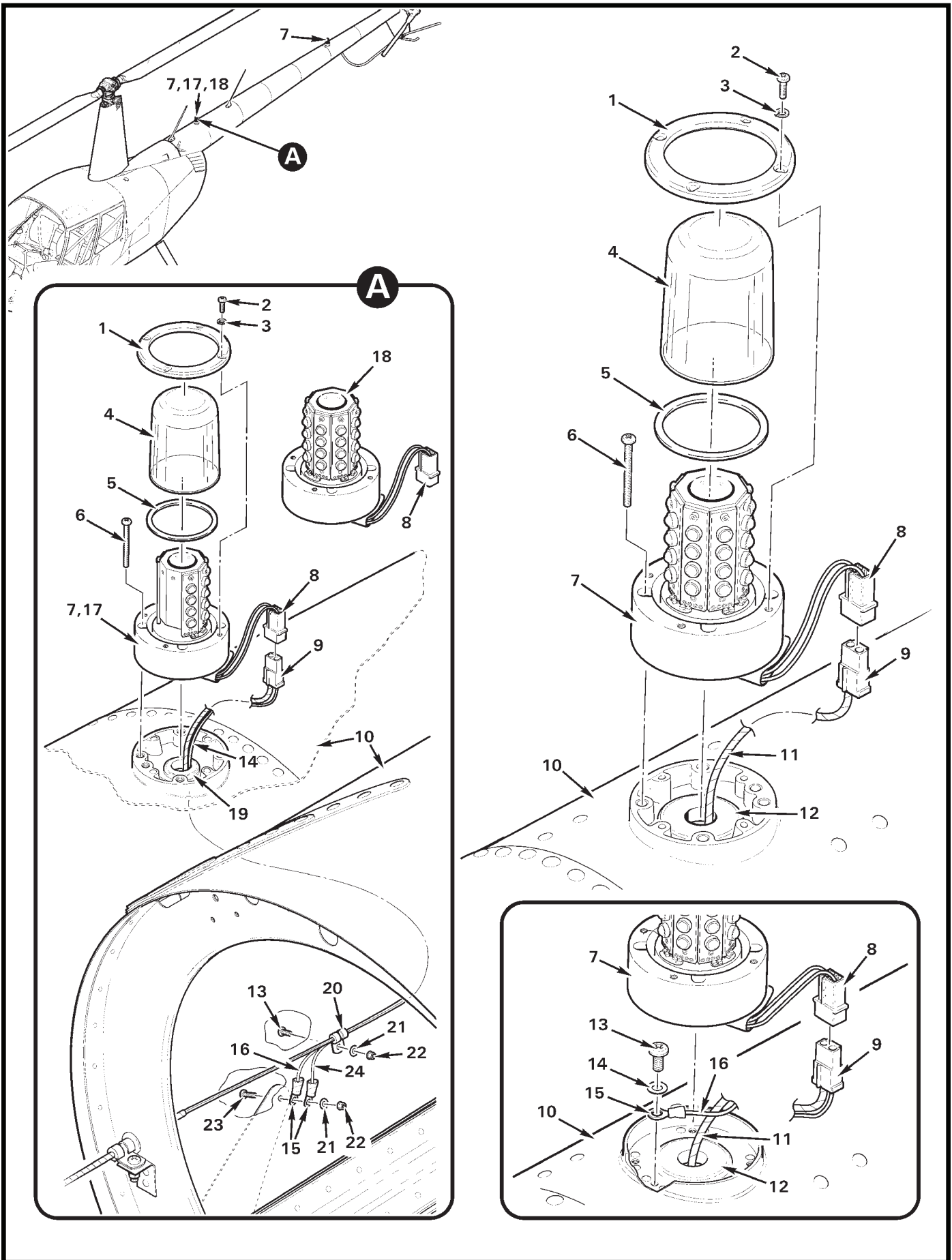

FIGURE AND INDEX NUMBER	PART NUMBER	DESCRIPTION	PARTS AVAIL	QTY PER ASSY
STROBE LIGHT INSTALLATION (LED)				
33-1-1	19-171047-100*	Retainer	O	1
2	14-0050505-14*	Screw	O	4
3	16-0050506135*	Lockwasher (MS35338-135)	O	4
4	68-4971082A30*	Lens	O	1
5	38-0250885-00*	Gasket	O	1
6	MS35206-234	Screw	X	4
7	A708-13**	Strobe Light – Red LED (28 volt; optional equipment in forward location. Includes items 1 thru 5, and 8.)	X	1
	A708-14**	Strobe Light – Red LED (14 volt; optional equipment in forward location. Includes items 1 thru 5, and 8.)	X	1
8	02-0230007-00*	Housing	O	1
	—	Pin	O	2
9	B263-13	Housing	X	1
	B263-2	Socket	X	2
10	C023	Tailcone Assembly (Ref)		
11	B161-2	Spirap	X	A/R
12	MS35489-15	Grommet	X	1
13	MS27039C0806	Screw	X	2
14	NAS1149FN832P	Washer	X	1
15	B260-3	Terminal	X	A/R
16	-2039	Wire (Ref; ground, aft strobe light, earlier R44s)		
17	A708-16**	Strobe Light – White LED (Optional equipment. Includes items 1 thru 5, and 8. Orient with blank strips facing forward.)	X	1
18	A708-15**	Strobe Light – Blue LED (Optional equipment. R44 Police only. Includes items 1 thru 5, and 8.)	X	1
19	MS35489-11	Grommet	X	1
20	MS21919WDG2	Clamp	X	1
21	NAS1149FN816P	Washer	X	2
22	MS21042L08	Nut	X	2
23	MS27039C0808	Screw	X	1
24	-2734	Wire (Ref; ground, forward strobe light)		

NOTES * Whelen part no.
 ** If not previously accomplished, earlier ships require KI-204 Airframe Provisions for Single LED-Strobe Tailcone Kit Installation if an LED-equipped tailcone is to be installed.

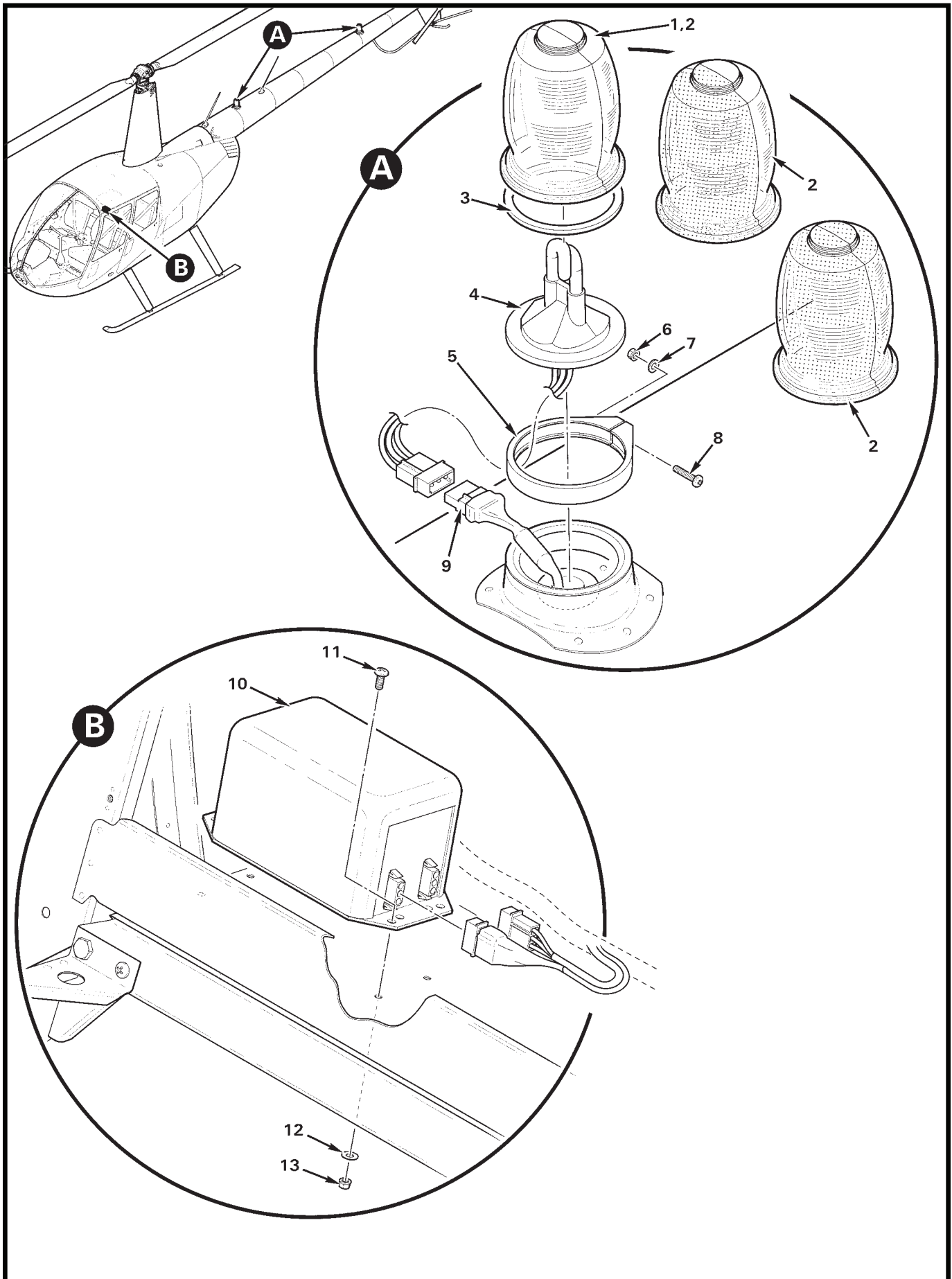
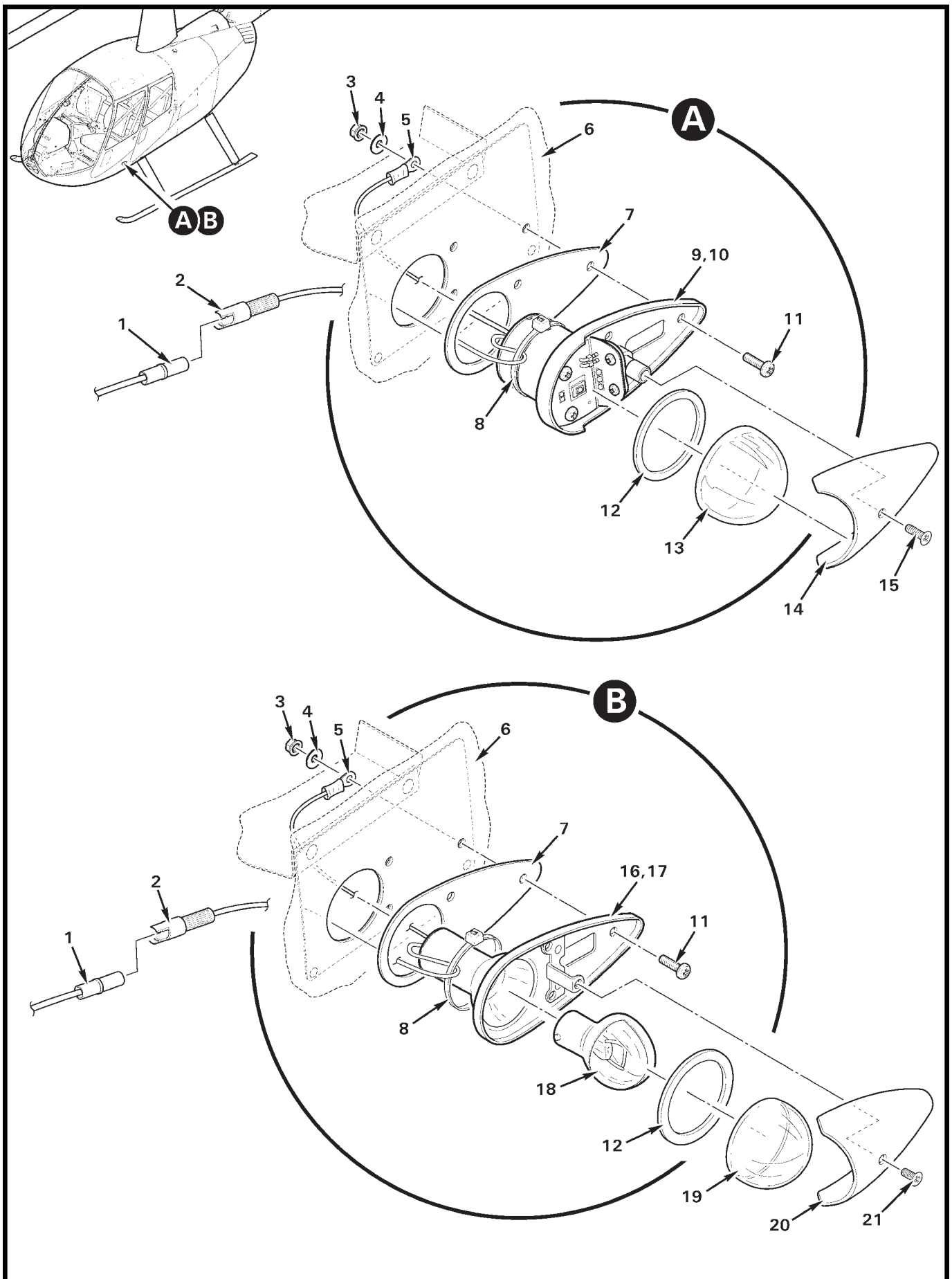

FIGURE AND INDEX NUMBER	PART NUMBER	DESCRIPTION	PARTS AVAIL	QTY PER ASSY
STROBE LIGHT INSTALLATION*				
33-3-1	A708-11	Strobe Light Assembly (Incl items 2 [A708-12], 3 thru 5, and 8)	X	1
2	A708-7	Lens Assembly (red)	X	1
	A708-10	Lens Assembly (white)	X	1
	A708-12	Lens Assembly (red and white)	X	1
3	38-0250429-00**	Gasket	O	1
4	A469B**	Flash Tube Assembly	X	1
5	01-0450685-00**	Clamp	X	1
6	MS21042L06	Nut	X	1
7	NAS620-6	Washer	X	1
8	—	Screw	O	1
9	B263-15	Housing (Ref; see Figure 53-33)		
10	A708-1	Strobe Power Supply	X	1
11	MS27039C0806	Screw	X	4
12	NAS1149FN816P	Washer	X	4
13	MS21042L08	Nut	X	4

NOTES * Earlier R44s.
 ** Whelen part no.



Page 33.4 FIGURE 33-5 NAVIGATION LIGHTS INSTALLATION – RIGHT AND LEFT POSITION FEB 2020

FIGURE AND INDEX NUMBER	PART NUMBER	DESCRIPTION	PARTS AVAIL	QTY PER ASSY
		NAVIGATION LIGHTS INSTALLATION – RIGHT AND LEFT POSITION*		
33-5-1	B263-11	Housing (Ref)		
2	B263-10	Housing	X	1
	B263-1	Pin	X	1
3	MS21042L06	Nut	X	3
4	NAS1149FN616P	Washer	X	3
5	B260-2	Terminal	X	1
6	C272-1	Chin (Ref)		
7	A779-1	Gasket	X	1
8	MS3367-5-9	Ty-Rap	X	1
9	A039-19	Position Light Assembly – LH (Red LED, 28-volt; includes items 2, 5, and 12 thru 15.)	X	1
	A039-21	Position Light Assembly – LH (Red LED, 14-volt; includes items 2, 5, and 12 thru 15.)	X	1
10	A039-20	Position Light Assembly – RH (Green LED, 28-volt; includes items 2, 5, and 12 thru 15. Not shown.)	X	1
	A039-22	Position Light Assembly – RH (Green LED, 14-volt; includes items 2, 5, and 12 thru 15. Not shown.)	X	1
11	MS35206-230	Screw	X	3
12	38-0230021-00**	Gasket	O	1
13	68-3950902A30**	Lens (clear)	X	1
14	19-150002-010**	Retainer	O	1
15	14-0050508-27**	Screw	O	1
16	A039-15	Position Light Assembly – LH (Red incandescent, 28-volt. Ref, no longer available.)		
	A039-5	Position Light Assembly – LH (Red incandescent, 14-volt. Ref, no longer available.)		
17	A039-16	Position Light Assembly – RH (Green incandescent, 28-volt. Ref, no longer available.)		
	A039-4	Position Light Assembly – RH (Green incandescent, 14-volt. Ref, no longer available.)		
18	W1290-14**	Lamp (14-volt)	X	1
	W1290-28**	Lamp (28-volt)	X	1
19	W1284R**	Lens – LH (red)	X	1
	W1284G**	Lens – RH (green, not shown)	X	1
20	W1282**	Retainer	X	1
21	—	Screw	O	1

NOTES * Refer to Figure 32-33 for position light installation with fixed floats installed.
 ** Whelen part no.

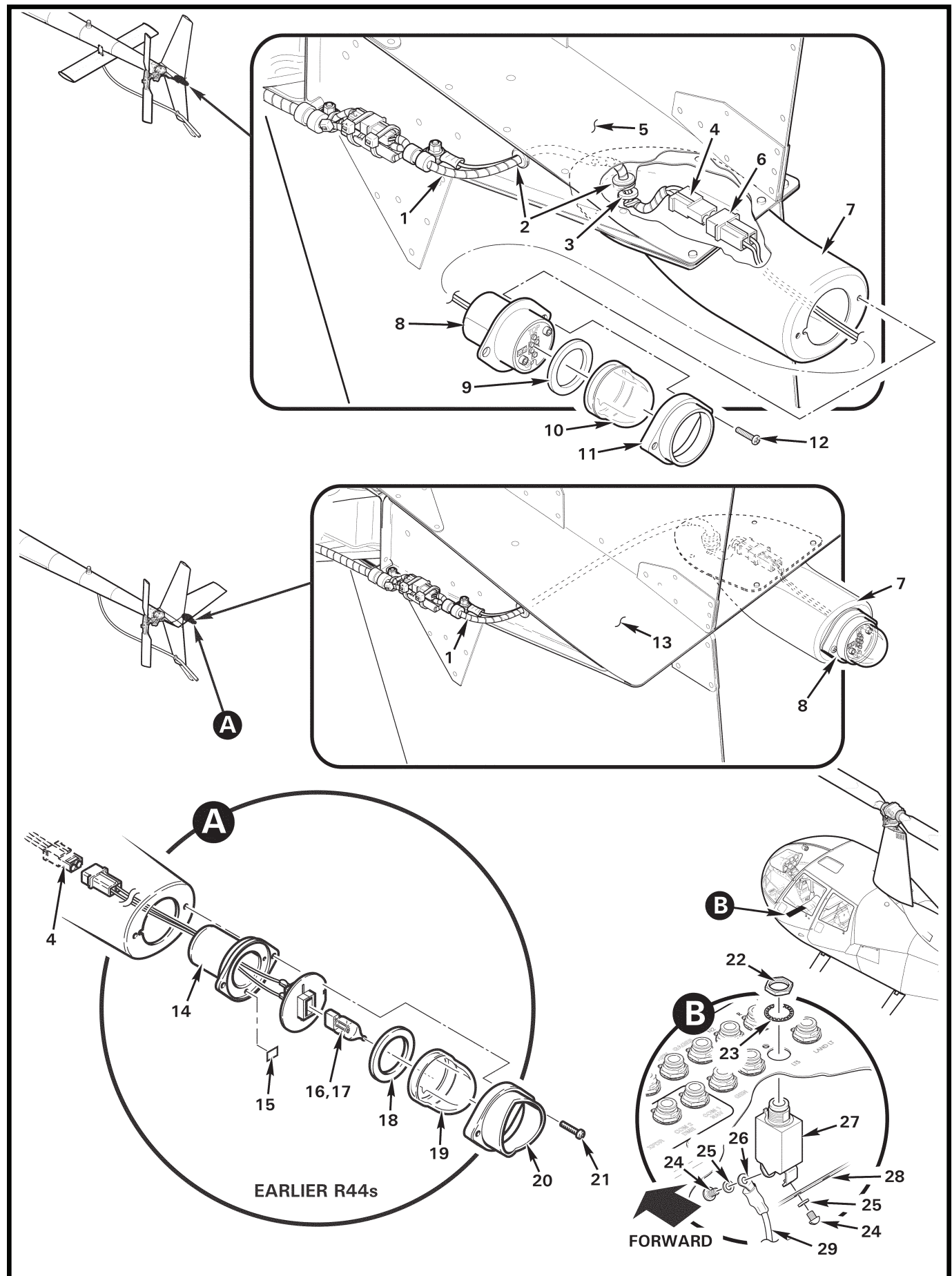

FIGURE AND INDEX NUMBER	PART NUMBER	DESCRIPTION	PARTS AVAIL	QTY PER ASSY
		NAVIGATION LIGHTS INSTALLATION – TAIL POSITION		
33-7-1	D049-8*	Wire Harness – Tail Light (Ref)		
	D049-3*	Wire Harness – Tail Light (Ref)		
2	MS35489-4*	Grommet (Ref)		
3	90295A075*	Washer (Ref)		
4	B263-13*	Housing (Ref)		
	B263-2*	Socket (Ref)		
5	F044-1	Mount Assembly (Ref, see Figure 53-37)		
6	B263-12	Housing	X	1
	B263-1	Pin	X	2
7	C529-1*	Mount Assembly – Tail Light (Ref)		
8	01-0771554-01**	Tail Light Assembly (LED, 28-volt; includes items 6, and 9 thru 12)	X	1
	01-0771554-11**	Tail Light Assembly (LED, 14-volt; includes items 6, and 9 thru 12)	X	1
9	38-0231061-00**	Gasket	O	1
10	68-3970991-30**	Lens	O	1
11	19-0150350-03**	Lens Retainer	O	1
12	14-0050505-18**	Screw	O	2
13	C044-1	Stabilizer – Horizontal (Ref, see Figure 53-41)		
14	A698-3	Tail Light Assembly (Ref, incandescent, 14-volt ships; no longer available. Superseded by item 8. Includes items 15 thru 21. See R44 MM § 26-12 Part C, also order item 1.) . . .		
15	A701-1	Foil Tape	X	A/R
16	34-0412070-63**	Lamp (halogen, 14-volt ships)	X	1
17	34-0428070-64**	Lamp (halogen, 28-volt ships)	X	1
18	A455**	Gasket	X	1
19	A457A**	Lens	X	1
20	A425**	Lens Retainer	X	1
21	–	Screw	O	2
22	–	Nut	O	1
23	–	Lockwasher	O	1
24	–	Screw	O	2
25	–	Washer	O	2
26	B260-2	Terminal (Ref)		
27	B297-5	Circuit Breaker (5 amp; includes items 22 thru 25)	X	1

NOTES * See Figures 53-37 and 53-41.
 ** Whelen part number.

Continues

FIGURE AND INDEX NUMBER	PART NUMBER	DESCRIPTION	PARTS AVAIL	QTY PER ASSY
<p>33-7-28 29</p>	<p>A448 -104</p>	<p>NAVIGATION LIGHTS INSTALLATION – TAIL POSITION (Cont'd)</p> <p>Bus Bar (Ref) Wire (Ref)</p>		
<p>NOTES</p>				

Intentionally Blank

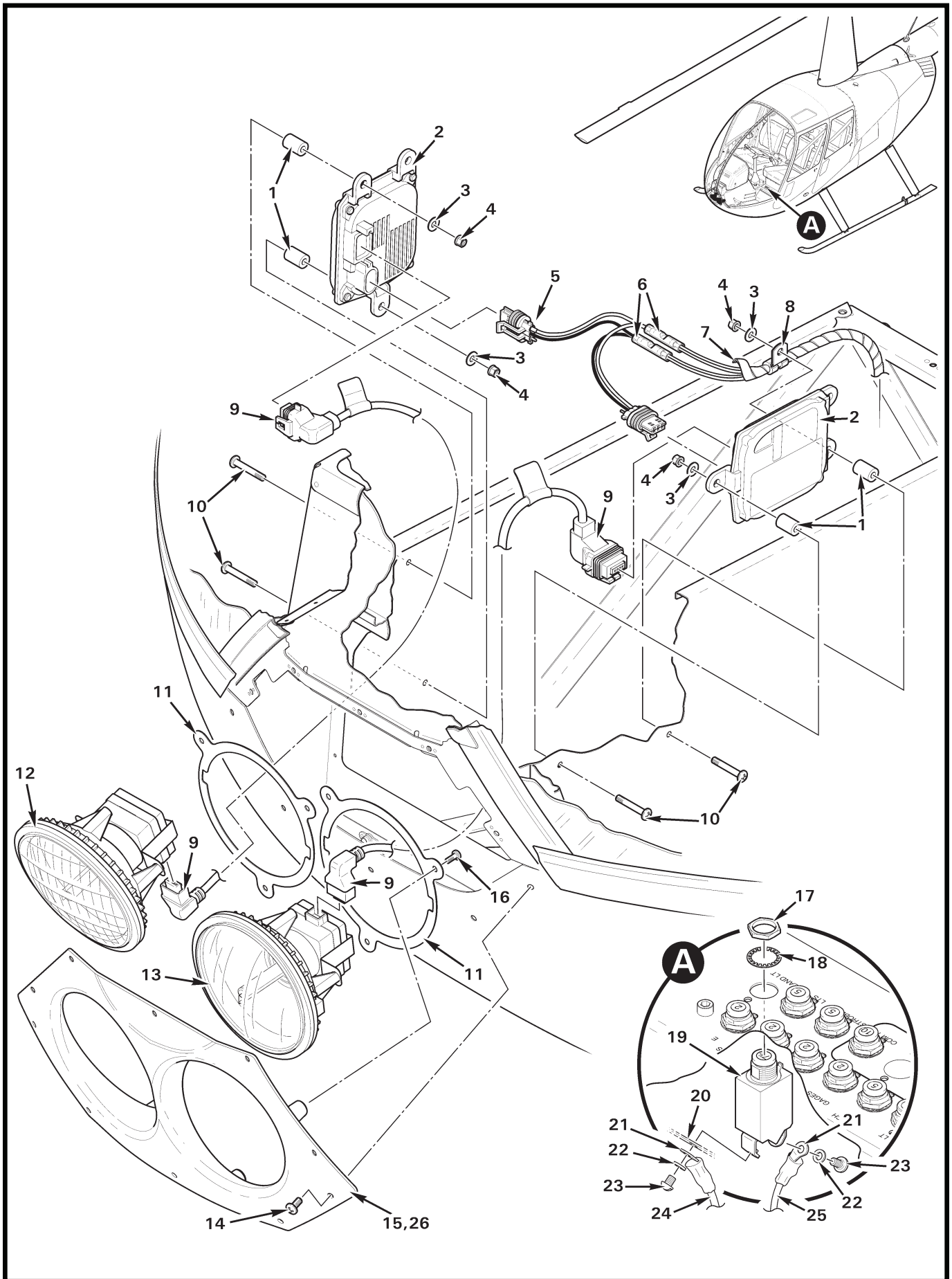

FIGURE AND INDEX NUMBER	PART NUMBER	DESCRIPTION	PARTS AVAIL	QTY PER ASSY
LANDING LIGHTS INSTALLATION (HID)				
33-11-1	A130-38	Spacer	X	4
2	B557-3	Ballast (28-volt; includes item 5)	X	2
	B557-5	Ballast (14-volt; includes item 5)	X	2
3	NAS1149FN832P	Washer	X	4
4	MS21042L08	Nut	X	4
5	B557-7	Power Cord (connector and wires)	X	2
6	B261-3	Splice	X	2
7	B161-4	Spirap	X	A/R
8	MS21919WDG2	Clamp	X	1
9	B557-8	Cable (long; 90° to 90°)	X	2
10	MS27039C0816	Screw	X	4
11	C526-3	Retainer	X	2
12	B557-2	Lamp – RH (HID, flood)	X	1
13	B557-1	Lamp – LH (HID, spot)	X	1
14	AN526C832R8	Screw	X	10
15	C526-2	Bezel (install using item 26 to seal edges)	X	1
16	MS35206-228	Screw	X	6
17	—	Nut	O	1
18	—	Lockwasher	O	1
19	B297-7	Circuit Breaker (7.5 amp; includes items 17, 18, 22, and 23)	X	1
20	A448-16	Bus Bar (Ref)		
21	B260-2	Terminal (Ref)		
22	—	Washer	O	2
23	—	Screw	O	2
24	-102	Wire (Ref)		
25	-2380	Wire (Ref; to landing lights relay)		
26	B270-13	Sealant (3-oz. tube)	X	A/R

NOTES

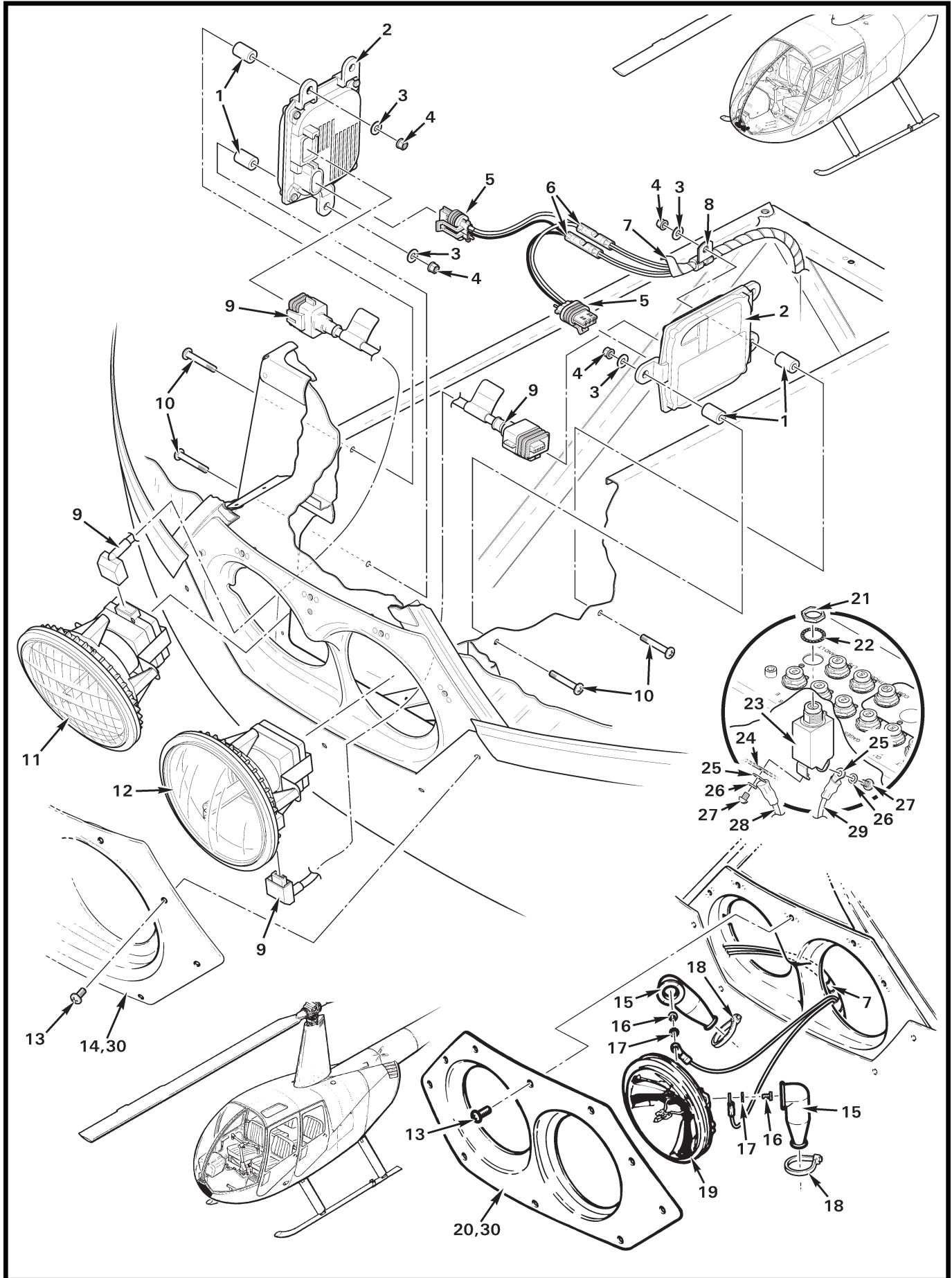

FIGURE AND INDEX NUMBER	PART NUMBER	DESCRIPTION	PARTS AVAIL	QTY PER ASSY
		LANDING LIGHTS INSTALLATION*		
33-13-1	A130-38	Spacer	X	4
2	B557-3	Ballast (28-volt; includes item 5)	X	2
	B557-5	Ballast (14-volt; includes item 5)	X	2
3	NAS1149FN832P	Washer	X	4
4	MS21042L08	Nut	X	4
5	B557-7	Power Cord (connector and wires)	X	2
6	B261-3	Splice	X	2
7	B161-4	Spirap	X	A/R
8	MS21919WDG2	Clamp	X	1
9	B557-8	Cable	X	2
10	MS27039C0816	Screw	X	4
11	B557-2	Lamp – RH (HID, flood)	X	1
12	B557-1	Lamp – LH (HID, spot)	X	1
13	AN526C832R8	Screw	X	10
14	C526-3	Retainer (install using item 30 to seal edges).	X	1
15	MS25171-2S	Nipple	X	4
16	—	Screw	O	4
17	—	Lockwasher	O	4
18	MS3367-4-9	Ty-Rap	X	4
19	B196-26	Lamp (14-volt, includes items 16 and 17. GE part no. Q4509)	X	2
	B196-27	Lamp (28-volt, includes items 16 and 17. GE part no. 4591)	X	2
20	C526-1	Retainer (install using item 30 to seal edges).	X	1
21	—	Nut	O	1
22	—	Lockwasher	O	1
23	B297-7	Circuit Breaker (20 amp; includes items 21, 22, 26, and 27)	X	1
24	A448-16	Bus Bar (Ref)		
25	B260-2	Terminal (Ref)		
26	—	Washer	O	2
27	—	Screw	O	2
28	-102	Wire (Ref)		
29	-103	Wire (Ref; to landing lights relay)		
30	B270-13	Sealant (3-oz. tube)	X	A/R

NOTES * Earlier R44s.

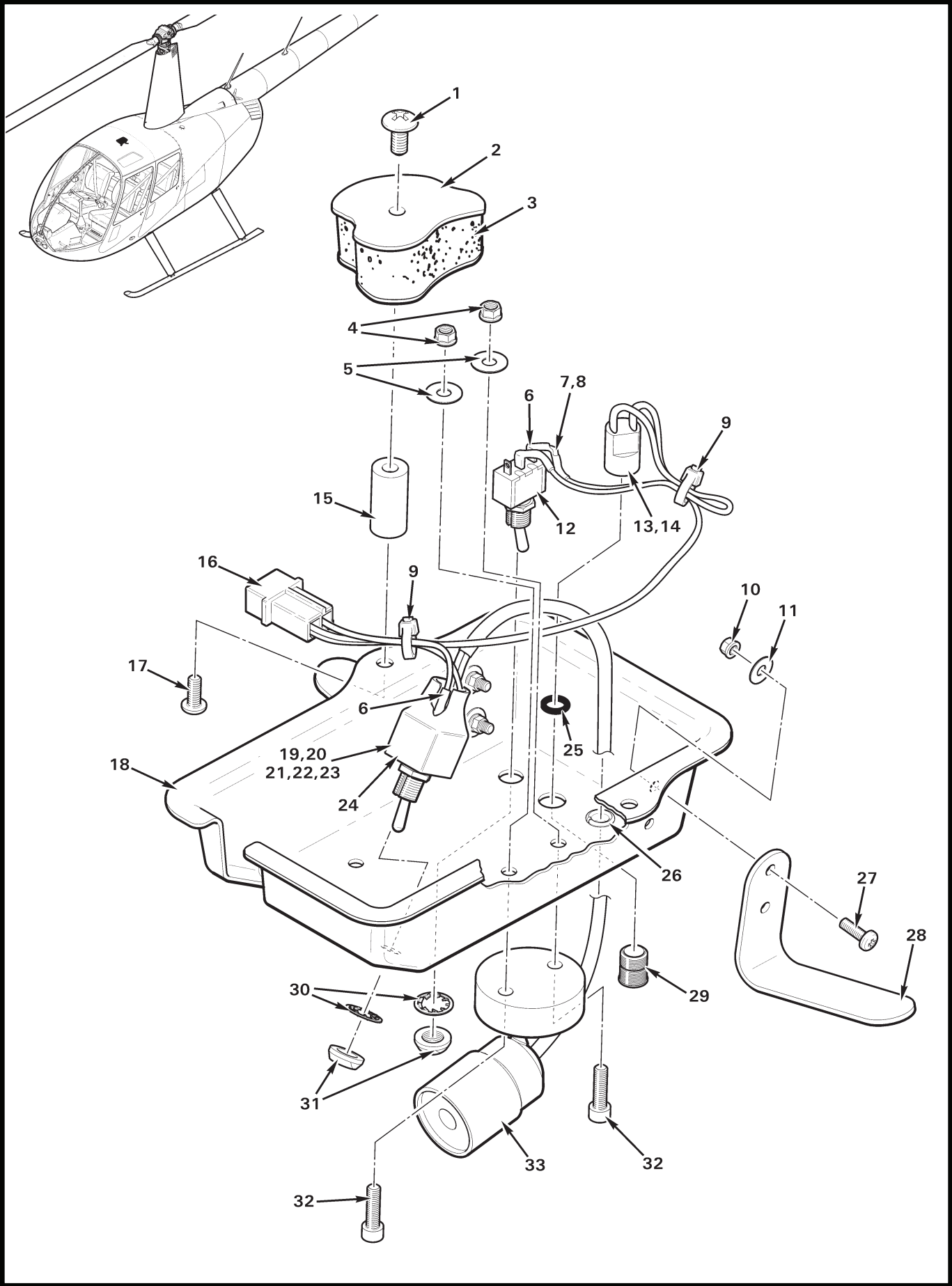

FIGURE AND INDEX NUMBER	PART NUMBER	DESCRIPTION	PARTS AVAIL	QTY PER ASSY
		SPOTLIGHT INSTALLATION (LED)		
33-15-1	AN526C832R6	Screw	X	2
2	C273-1	Roof (Ref)		
3	C003	Insulation – Fwd (RH, Ref. See Figure 25-23.)		
4	MS21042L06	Nut	X	2
5	NAS1149FN616P	Washer	X	2
6	B158-2	Heat Shrink (around leads)	X	A/R
7	B0207C511R0F5T*	Resistor	X	1
8	B0207C1K210F5T**	Resistor	X	1
9	MS3367-4-9	Ty-Rap	X	2
10	MS21042L04	Nut	X	4
11	NAS1149FN416P	Washer	X	4
12	B300-1	Switch Assembly (Incl items 30 and 31)	X	1
13	CNX310000X4112	Connector	X	1
14	E1003	LED (not shown)	X	1
15	C710-3	Spacer	X	2
16	B263-12	Housing	X	1
	B263-1	Pin	X	2
17	MS27039C0806	Screw	X	2
18	C712-2	Cover	X	1
19	B300-5	Switch Assembly (Incl items 30 and 31)	X	1
20	B0207C422R0F5T*	Resistor (not shown)	X	1
21	B0207C1K430F5T*	Resistor (not shown)	X	1
22	B0207C1K650F5T**	Resistor (not shown)	X	1
23	B0207C3K400F5T**	Resistor (not shown)	X	1
24	B158-12	Heat Shrink	X	A/R
25	A215-008	O-Ring	X	1
26	NAS557-3A	Grommet	X	1
27	MS35206-215	Screw	X	4
28	A752-1	Angle	X	2
29	CMC321-CTP	Lens	X	1
30	B227-3	Lockwasher	X	2
31	B227-4	Dress Nut	X	2
32	NAS1352-06-8	Screw	X	2
33	D606-1	Spotlight	X	1

NOTES * 14-volt ships only.
 ** 28-volt ships only.

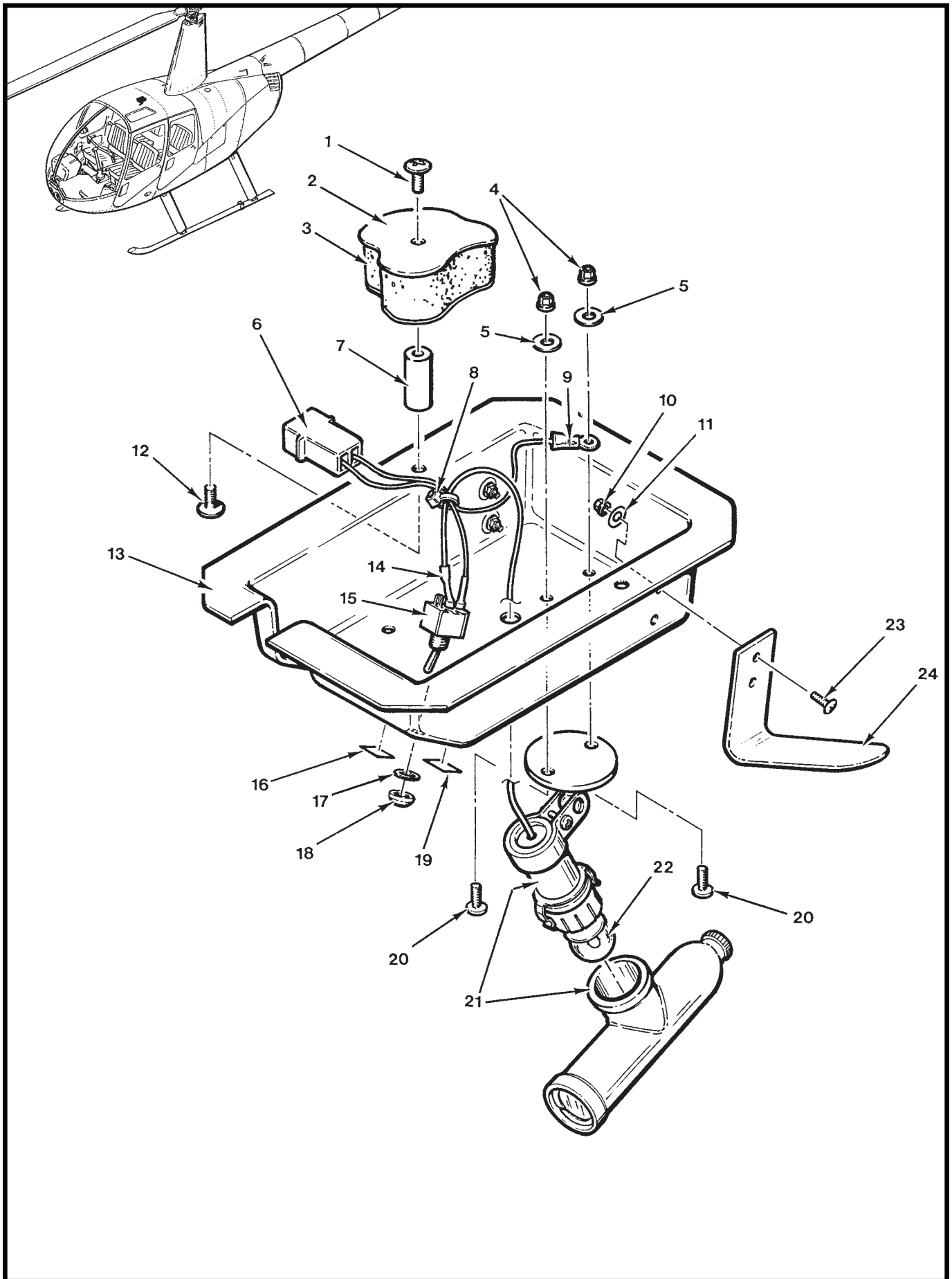

FIGURE AND INDEX NUMBER	PART NUMBER	DESCRIPTION	PARTS AVAIL	QTY PER ASSY
		SPOTLIGHT INSTALLATION*		
33-17-1	AN526C832R6	Screw	X	2
2	C273-1	Roof (Ref)		
3	C003	Insulation – Fwd (RH, Ref; see Figure 25-23)		
4	MS21042L06	Nut	X	2
5	NAS1149FN616P	Washer	X	2
6	B263-12	Housing	X	1
	B263-1	Pin	X	2
7	C710-3	Spacer	X	2
8	MS3367-4-9	Ty-Rap	X	A/R
9	B260-2	Terminal	X	1
10	MS21042L04	Nut	X	4
11	NAS1149FN416P	Washer	X	4
12	MS27039C0806	Screw	X	2
13	C712-1	Cover (Ref; no longer available)	O	1
14	B158-2	Heat Shrink (both wires)	X	A/R
15	B300-1	Switch Assembly – Spotlight (Incl items 17 and 18)	X	1
16	A654-15	Decal – “On”	X	1
17	B227-3	Lockwasher	X	1
18	B227-4	Dress Nut	X	1
19	A654-13	Decal – “Off”	X	1
20	MS35206-228	Screw	X	2
21	A1425A-2	Spotlight Assembly (does not include item 22)	X	1
22	B196-2	Lamp (14-volt ships)	X	1
	B196-22	Lamp (28-volt ships)	X	1
23	MS35206-215	Screw	X	4
24	A752-1	Angle	X	2

NOTES * Earlier R44s.

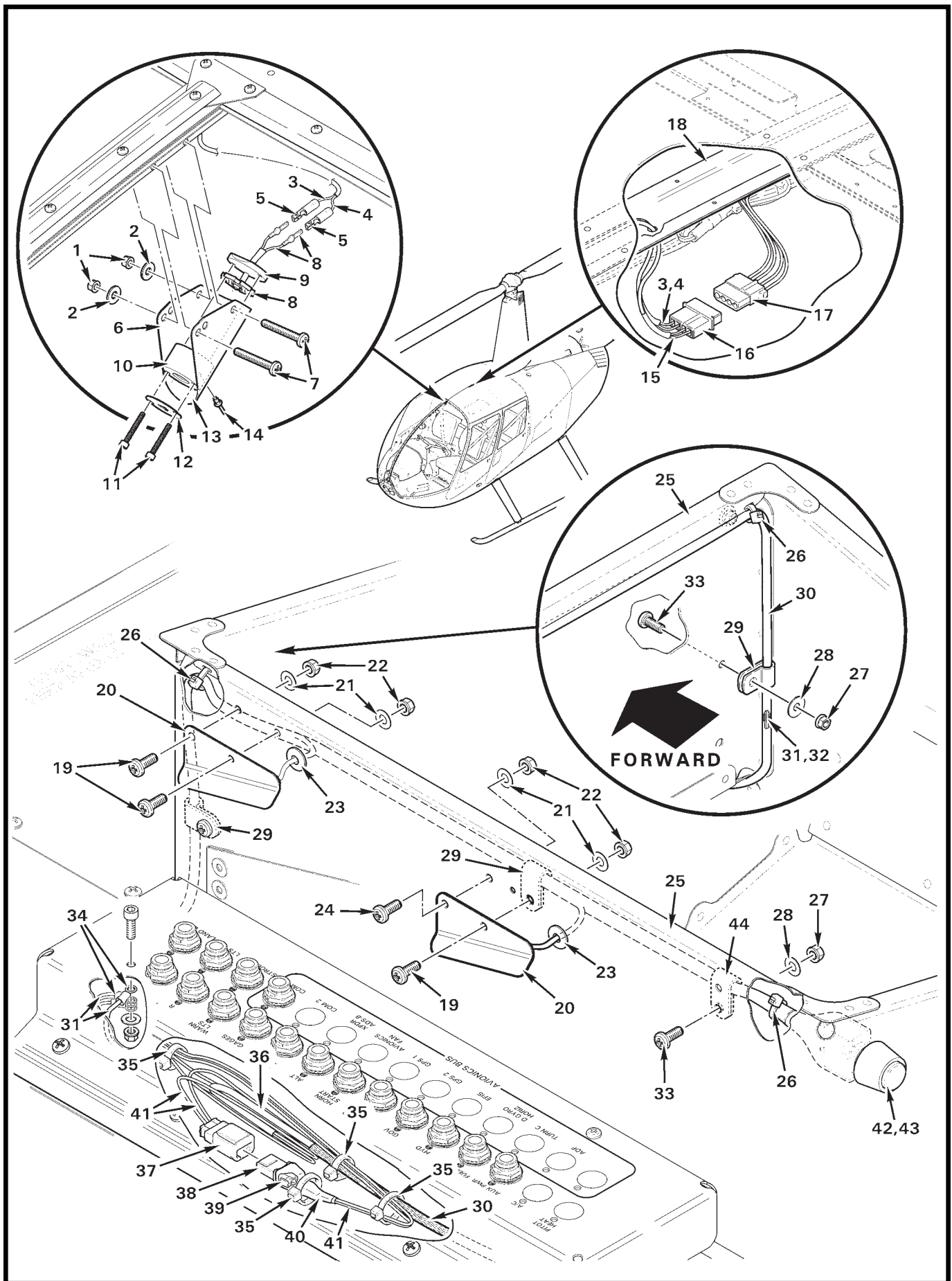

FIGURE AND INDEX NUMBER	PART NUMBER	DESCRIPTION	PARTS AVAIL	QTY PER ASSY
CABIN INTERIOR LIGHTING INSTALLATION				
33-19-1	NAS1291C08M	Nut	X	2
2	NAS1149DN816J	Washer	X	2
3	C238-2289	Wire (Ref)		
4	C238-2290	Wire (Ref)		
5	B262-1	Terminal	X	2
6	G196-8	Light Assembly – Console (Incl items 8 thru 14)	X	1
7	MS35214-47	Screw	X	2
8	G196-2	LED Assembly	X	1
9	G197-5	Cover	X	1
10	G197-10	Housing	X	1
11	91251A113	Screw	X	2
12	G197-9	Window	X	1
13	G197-11	Bracket	X	1
14	NAS9301B-4-02	Rivet	X	1
15	C238-125	Wire (Ref, compass light)		
	C238-126	Wire (Ref, compass light)		
16	B263-16	Housing	X	1
	B263-1	Pin	X	4
17	B263-17	Housing	X	1
	B263-2	Socket	X	4
18	C087-3	Support – Roof (Ref)		
19	MS27039C0806	Screw	X	2
20	G196-7	Light Assembly – Circuit Breaker Panel (Incl items 23, 31,32, and 34)	X	2
21	NAS1149FN816P	Washer	X	4
22	MS21042L08	Nut	X	4
23	MS35489-4	Grommet	X	2
24	MS27039C0805	Screw	X	2
25	C297-4	Support – Seat (Ref; forward, LH)		
26	MS3367-4-0	Ty-Rap	X	4
27	MS21042L06	Nut	X	2
28	NAS1149FN616P	Washer	X	2
29	N-4-BK	Clamp	X	1
30	B266-4	Sleeving	X	A/R
31	-2291	Wire (Ref; ground)		

NOTES

Continues

FIGURE AND INDEX NUMBER	PART NUMBER	DESCRIPTION	PARTS AVAIL	QTY PER ASSY
CABIN INTERIOR LIGHTING INSTALLATION (Cont'd)				
33-19-32	-127	Wire (Ref; power)		
33	MS35206-228	Screw	X	1
34	B260-3	Terminal	X	2
35	MS3367-4-9	Ty-Rap	X	A/R
36	B158-2	Heat Shrink	X	A/R
37	D269-1	Plug	X	1
38	D269-2	Receptacle	X	1
39	D269-21	Backshell	X	1
40	B158-6	Heat Shrink	X	A/R
41	C859-127	Wire (Ref; power)		
42	C049-18	Harness Assembly (Incl items 26, 30 thru 32, B158-8 heat shrink, and B263-1 pins)	X	1
43	B227-8	Switch Assembly	X	1
44	N-3-BK	Clamp	X	1

NOTES

CHAPTER 52

DOORS AND WINDOWS

<i>Figure</i>	<i>Title</i>	<i>Page</i>
52-1	Forward Door Assembly	52.0
52-7	Aft Door Assembly	52.6
52-11	Aft Door Assembly – R44 Cadet	52.10
52-13	Windshield Installation	52.12
52-17	Windshield Installation – Impact-Resistant (Polycarbonate)	52.16
52-21	Windshield Installation – Impact-Resistant (Polycarbonate)	52.20

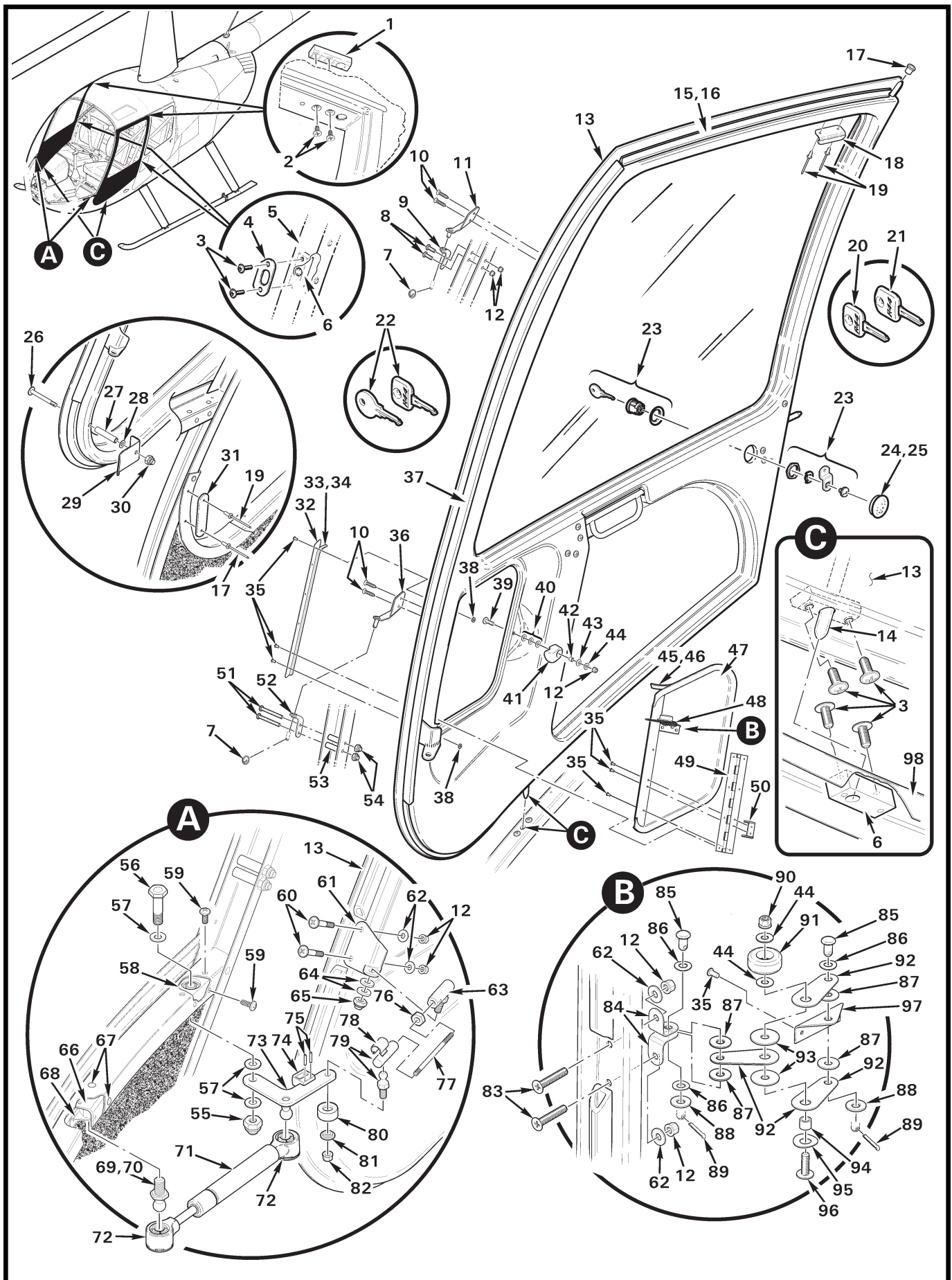

FIGURE AND INDEX NUMBER	PART NUMBER	DESCRIPTION	PARTS AVAIL	QTY PER ASSY
FORWARD DOOR ASSEMBLY				
52-1-1	C537-16	Block	X	2
2	93195A322	Screw	X	4
3	AN525-832R6	Screw	X	2
4	C538-1	Plate	X	1
5	C403	Door Post (Ref)		
6	C537-11	Block	X	2
7	B427-1	Ring – Cotter	X	2
8	MS27039C0807	Screw	X	2
9	A228-1	Hinge Assembly (RH and LH, upper)	X	1
10	MS51861-37C	Screw (self-tapping)	X	4
11	C227-4	Hinge Assembly (RH, upper)	X	1
	C227-3	Hinge Assembly (LH, upper)	X	1
12	MS21042L08	Nut	X	7
13	C026-012*	Door Assembly** (RH, clear; includes items 7, 14, 15, 18 thru 22, 24, 26, 30 thru 47, 52 thru 54, 73 thru 76, and 78 thru 86)	X	1
	C026-011*	Door Assembly** (LH, clear; includes items 7, 14, 15, 18 thru 22, 24, 26, 30 thru 47, 52 thru 54, 73 thru 76, and 78 thru 86; not shown)	X	1
	C026-022*	Door Assembly** (RH, light tint; includes items 7, 14, 15, 18 thru 22, 24, 26, 30 thru 47, 52 thru 54, 73 thru 76, and 78 thru 86; not shown)	X	1
	C026-021*	Door Assembly** (LH, light tint; includes items 7, 14, 15, 18 thru 22, 24, 26, 30 thru 47, 52 thru 54, 73 thru 76, and 78 thru 86; not shown)	X	1
	C026-032*	Door Assembly** (RH, bubble, clear; includes items 7, 14, 15, 18 thru 22, 24, 26, 30 thru 47, 52 thru 54, 73 thru 76, and 78 thru 86; not shown)	X	1
	C026-031*	Door Assembly** (LH, bubble, clear; includes items 7, 14, 15, 18 thru 22, 24, 26, 30 thru 47, 52 thru 54, 73 thru 76, and 78 thru 86; not shown)	X	1
	C026-042*	Door Assembly** (RH, bubble, tinted; includes items 7, 14, 15, 18 thru 22, 24, 26, 30 thru 47, 52 thru 54, 73 thru 76, and 78 thru 86; not shown)	X	1
	C026-041*	Door Assembly** (LH, bubble, tinted; includes items 7, 14, 15, 18 thru 22, 24, 26, 30 thru 47, 52 thru 54, 73 thru 76, and 78 thru 86; not shown)	X	1

NOTES * Will be shipped painted white.
 ** Ship S/N 2380 and prior, S/N 10001 thru 13760 may require KI-244, unless kit was previously installed, or doors with item 14 were factory-installed.

Continues

FIGURE AND INDEX NUMBER	PART NUMBER	DESCRIPTION	PARTS AVAIL	QTY PER ASSY
FORWARD DOOR ASSEMBLY (Cont'd)				
52-1-14	C224-13	Rod Assembly (Ref)		
15	A226-2	Seal (bond using item 16)	X	A/R
16	B270-18	Adhesive (5-oz. tube)	X	A/R
17	2017	Bushing	X	1
	NAS557-4B	Grommet (earlier R44s)	X	1
18	C223-1	Angle	X	2
19	B204-1*	Rivet (blind; alternate part no. 01610-11041)	X	A/R
20	D768-2	Key – Blank (black plastic-coated brass key, "R44" logo)	X	2
21	D768-10	Key – Blank (black plastic-coated, "R44" logo; earlier R44s)	O	1
22	R8427	Key – Duplicate (black plastic-coated brass key, "R44" logo)	X	1
	R8096	Key – Duplicate (small brass key without black plastic coating or "R44" logo)	X	1
23	A556-1	Door Lock (with 2 keys, round head)	X	1
	A556-3	Door Lock (with 2 keys, square head; earlier R44s, not shown)	O	1
24	2713	Hole Plug (bond using item 25)	X	1
25	B270-9	Adhesive (2-oz. kit)	X	A/R
26	AN525-832R24*	Screw	X	1
27	C130-19*	Spacer	X	1
28	NAS1149FN816P	Washer (as required for shimming)	X	A/R
29	A768-2*	Clip (RH)	X	1
	A768-1*	Clip (LH; not shown)	X	1
30	B340-4*	Nut	X	2
31	A767-1*	Rub Strip (RH and LH)	X	2
32	C682-2	Barrier	X	1
33	A226-3	Seal (bond using item 34)	X	A/R
34	B270-8.2OZ	Adhesive (2-oz. container)	X	A/R
35	MS20470AD3	Rivet	X	13
36	C227-2	Hinge Assembly (RH, lower)	X	1
	C227-1	Hinge Assembly (LH, lower)	X	1
37	A226-6	Seal (forward door edge, self-adhesive)	X	A/R
38	NAS1149FN232P	Washer	X	2

NOTES * Earlier doors (C026 Rev AG or prior).

Continues

FIGURE AND INDEX NUMBER	PART NUMBER	DESCRIPTION	PARTS AVAIL	QTY PER ASSY
FORWARD DOOR ASSEMBLY (Cont'd)				
52-1-39	AN525-832R10	Screw	X	1
40	NAS1149FN816P	Washer (or NAS1149FN832P for proper seal compression) . .	X	A/R
41	C285-1	Knob	X	1
42	C130-5	Spacer	X	1
43	U216-0100-S	Spring Washer (alternate part no. U216-0100S or U216-0100)	X	1
44	NAS1149FN816P	Washer	X	2
45	A226-7	Seal (bond using item 46; 3 sides of vent door)	X	A/R
46	B270-8.2OZ	Adhesive (2-oz. container)	X	A/R
47	C425-2	Vent Door (RH, forward; door only)	X	1
	C425-1	Vent Door (LH, forward; door only)	X	1
48	A425-17	Arm Assembly (LH and RH; includes items 44, and 84 thru 97)	X	1
49	C425-5	Hinge	X	1
50	B242-2	Stop	X	1
51	MS27039C0824	Screw	X	2
52	C228-1	Hinge Assembly	X	1
53	C130-37	Spacer	X	2
54	B340-4	Nut	X	4
55	B340-10	Nut	X	1
56	NAS6604-12	Bolt	X	1
57	NAS1149F0432P	Washer	X	3
58	D573-1	Block	X	1
59	MS27039C0806	Screw	X	4
60	AN525-832R16	Screw	X	2
61	D574-4	Bracket (RH)	X	1
	D574-3	Bracket (LH, not shown)	X	1
62	NAS1149FN832P	Washer	X	2
63	D575-3	Ball Joint	X	1
64	NAS1149F0363P	Washer	X	2
65	B340-8	Nut	X	2
66	D573-3	Block (install using item 67)	X	1

NOTES

Continues

FIGURE AND INDEX NUMBER	PART NUMBER	DESCRIPTION	PARTS AVAIL	QTY PER ASSY
FORWARD DOOR ASSEMBLY (Cont'd)				
52-1-67	MS20470AD4	Rivet	X	6
68	D573-5	Angle	X	1
69	C394-2	Ball Stud (use item 70 on threads)	X	1
70	B270-10	Adhesive (1.69-oz. bottle)	X	A/R
71	D575-1	Gas Spring	X	1
72	PS130	End Connector	X	2
73	D574-2	Arm Assembly (RH; includes items 74 and 75)	X	1
	D574-1	Arm Assembly (LH, not shown; includes items 74 and 75)	X	1
74	D573-7	Bumper	X	1
75	MS16562-4	Spring Pin	X	2
76	AN315-3R	Nut	X	1
77	D573-4	Rod	X	1
78	P-8100	Clip	X	1
79	D575-2	Ball Joint (Incl item 78)	X	1
80	C119-3	Bumper	X	1
81	B138-2	Spacer	X	1
82	D210-3	Nut	X	2
83	MS24694-S11	Screw	X	2
84	A425-19	Clip	X	2
85	MS20392-2C7	Pin	X	2
86	U190-0090-S	Spring Washer (alternate part no. U190-0090S)	X	3
87	A141-8	Washer	X	4
88	NAS1149F0332P	Washer	X	2
89	MS24665-151	Cotter Pin	X	2
90	MS21042L08	Nut	X	1
91	A431-1	Knob	X	1
92	A425-7	Arm	X	3
93	A141-7	Washer	X	2
94	A105-7	Journal	X	1
95	CRV-26152	Spring Washer (alternate part no. U250-0185-S or U250-0185)	X	1
96	AN525-832R8	Screw	X	1

NOTES

Continues

FIGURE AND INDEX NUMBER	PART NUMBER	DESCRIPTION	PARTS AVAIL	QTY PER ASSY
FORWARD DOOR ASSEMBLY (Cont'd)				
52-1-97	A425-13	Angle	X	1
98	C238-8	Sill (Ref, RH)		
	C238-7	Sill (Ref, LH; not shown)		
		* * *		
99	KI-244-1 *	(LH) R44-series Forward Door Kit Instructions (For upgrading to forward doors with C224-13 rod assembly [bottom latching rod, door not included].)	X	A/R
	KI-244-2 *	(RH) R44-series Forward Door Kit Instructions (see above) . . .	X	A/R
100	KI-259	R44/R66 Door Closure Assist Finger Tab Installation Kit Instructions (installs item 18)	X	A/R

NOTES * Ship S/N 2380 and prior, S/N 10001 thru 13760 may require KI-244, unless kit was previously installed, or doors with item 14 were factory-installed.

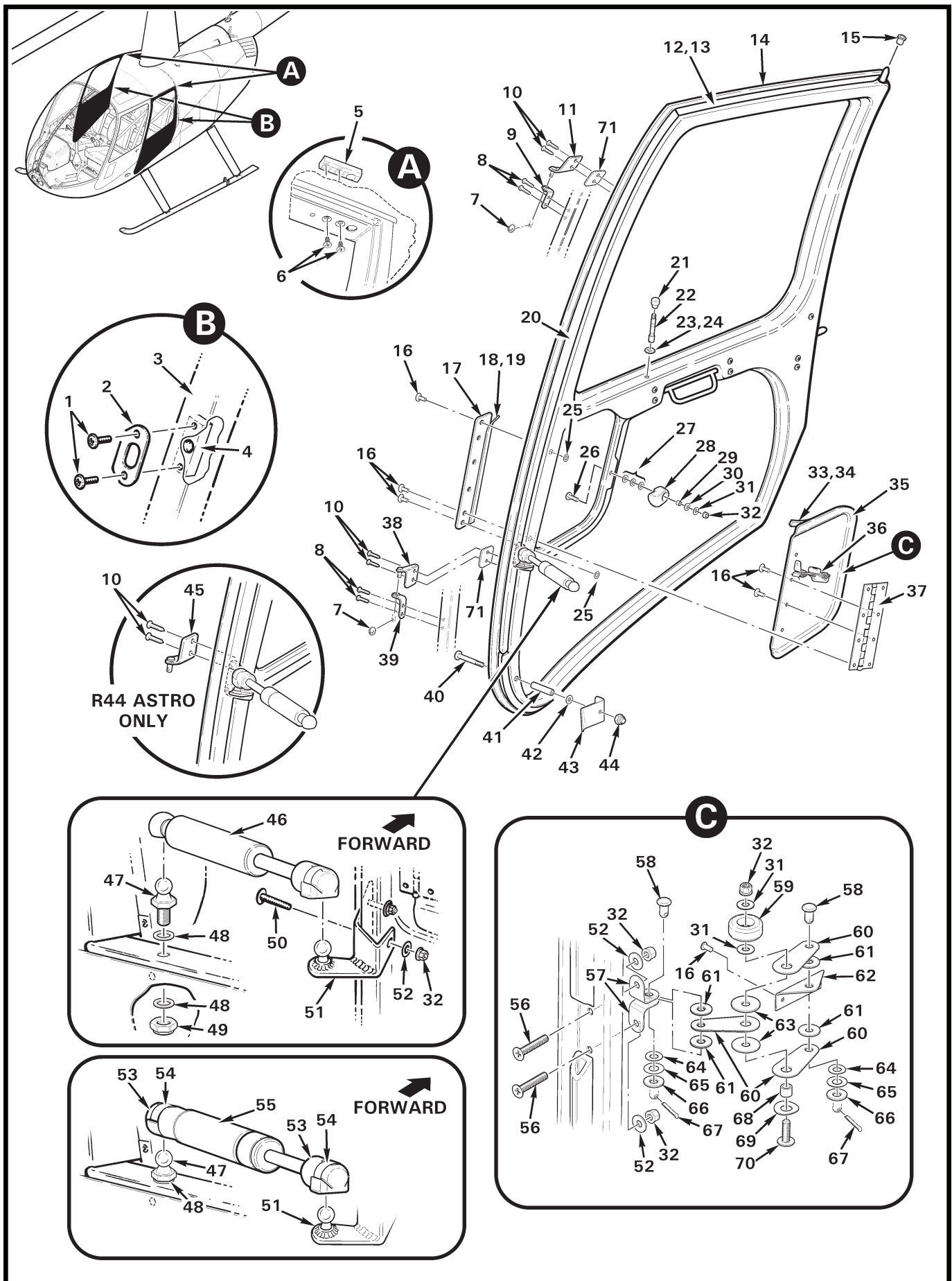

FIGURE AND INDEX NUMBER	PART NUMBER	DESCRIPTION	PARTS AVAIL	QTY PER ASSY
		AFT DOOR ASSEMBLY*		
52-7-1	AN525-832R6	Screw (do not substitute MS27039 screws)	X	2
2	C538-1	Plate	X	1
3	C238	Door Jamb (Ref)		
4	C537-11	Block	X	1
5	C537-16	Block	X	1
6	D216-2	Screw (or 93195A322)	X	2
7	B427-1	Ring – Cotter	X	2
8	MS27039C0810	Screw	X	4
9	A228-1	Hinge	X	1
10	MS51861-37C	Screw	X	4
11	C389-4	Hinge Assembly (RH, upper)	X	1
	C389-3	Hinge Assembly (LH, upper)	X	1
12	A226-2	Seal (bond using item 13)	X	A/R
13	B270-18PT	Adhesive	X	A/R
14	C026-014**	Door Assembly (RH, clear; includes items 12, 13, 15, 16 thru 37, 49, and 50)	X	1
	C026-013**	Door Assembly (LH, clear; includes items 12, 13, 15, 16 thru 37, 49, and 50; not shown)	X	1
	C026-024**	Door Assembly (RH, light tint; includes items 12, 13, 15, 16 thru 37, 49, and 50; not shown)	X	1
	C026-023**	Door Assembly (LH, light tint; includes items 12, 13, 15, 16 thru 37, 49, and 50; not shown)	X	1
	C026-034**	Door Assembly (RH, bubble, clear; includes items 12, 13, 15, 16 thru 37, 49, and 50; not shown)	X	1
	C026-033**	Door Assembly (LH, bubble, clear; includes items 12, 13, 15, 16 thru 37, 49, and 50; not shown)	X	1
	C026-044**	Door Assembly (RH, bubble, light tint; includes items 12, 13, 15, 16 thru 37, 49, and 50; not shown)	X	1
	C026-043**	Door Assembly (LH, bubble, light tint; includes items 12, 13, 15, 16 thru 37, 49, and 50; not shown)	X	1
	C026-054**	Door Assembly (RH, dark tint; includes items 12, 13, 15, 16 thru 37, 49, and 50; not shown)	X	1
	C026-053**	Door Assembly (LH, dark tint; includes items 12, 13, 15, 16 thru 37, 49, and 50; not shown)	X	1
	C026-064**	Door Assembly (RH, bubble, dark tint; includes items 12, 13, 15, 16 thru 37, 49, and 50; not shown)	X	1
	C026-063**	Door Assembly (LH, bubble, dark tint; includes items 12, 13, 15, 16 thru 37, 49, and 50; not shown)	X	1

NOTES * Ship S/N 0001 thru 9999, and S/N 10001 thru 29999.

** Will be shipped painted white.

Continues

FIGURE AND INDEX NUMBER	PART NUMBER	DESCRIPTION	PARTS AVAIL	QTY PER ASSY
AFT DOOR ASSEMBLY (Cont'd)				
52-7-15	2017	Bushing	X	1
	NAS557-4B	Grommet (not shown, earlier R44s)	X	1
16	MS20470AD3	Rivet	X	12
17	C682-1	Barrier	X	1
18	A226-3	Seal (bond using item 19)	X	A/R
19	B270-8.2OZ	Adhesive (2-oz. container)	X	A/R
20	A226-6	Seal	X	A/R
21	A431-2	Knob (door lock)	X	1
	1770	Knob (Ref; not shown, earlier R44s. Replaced by A431-2.)		
22	C544-1	Pin	X	1
23	C26005	Washer (bond using item 24)	X	1
24	B270-9	Adhesive (2-oz. kit)	X	A/R
25	NAS1149FN232P	Washer	X	2
26	AN525-832R	Screw	X	1
27	NAS1149FN816P	Washer (or NAS1149FN832P for proper seal compression)	X	A/R
28	C285-1	Knob	X	1
29	C130-5	Spacer	X	1
30	U216-0100-S	Spring Washer (alternate part no. CRV-25134 or U216-0100)	X	1
31	NAS1149FN816P	Washer	X	3
32	MS21042L08	Nut	X	6
33	A226-7	Seal (bond using item 34; [3] sides of vent door)	X	A/R
34	B270-8.2OZ	Adhesive (2-oz. container)	X	A/R
35	C425-4	Vent Door (RH)	X	1
	C425-3	Vent Door (LH)	X	1
36	A425-17	Arm Assembly (LH and RH, includes items 31 [2], 32 [1], 57 thru 70)	X	1
37	C425-5	Hinge	X	1
38	C389-10	Hinge Assembly (RH, lower)	X	1
	C389-9	Hinge Assembly (LH, lower)	X	1
39	A228-2	Hinge	X	1
40	AN525-832R24*	Screw	X	1
41	C130-19*	Spacer	X	1
42	NAS1149FN816P*	Washer (as required for shimming)	X	A/R
43	A768-2*	Clip (RH)	X	1
44	B340-4*	Nut	X	1

NOTES * Earlier R44s.

Continues

FIGURE AND INDEX NUMBER	PART NUMBER	DESCRIPTION	PARTS AVAIL	QTY PER ASSY
AFT DOOR ASSEMBLY (Cont'd)				
52-7-45	C389-2	Hinge Assembly (RH, lower; R44 Astro)	X	1
	C389-1	Hinge Assembly (LH, lower; R44 Astro)	X	1
46	C394-1	Gas Spring	X	1
47	C394-2	Ball Stud	X	1
48	C141-15	Washer	X	2
49	21FKF-518	Nut	X	1
50	MS27039C0816	Screw	X	2
51	C393-2	Bracket Weldment (RH)	X	1
	C393-1	Bracket Weldment (LH)	X	1
52	NAS1149FN832P	Washer	X	1
53	PC1249-2*	End Connector (Incl item 54)	X	2
54	-	Clip (Ref)		
55	C394-1*	Gas Spring (Ref; revision I and prior no longer available)		
56	MS24694-S11	Screw	X	2
57	A425-19	Clip	X	2
58	MS20392-2C7	Clevis Pin	X	2
59	A431-1	Knob	X	1
60	A425-7	Arm	X	3
61	A141-8	Washer	X	4
62	A425-13	Angle	X	1
63	A141-7	Washer	X	2
64	U190-0090-S	Spring Washer (alternate part no. U190-0090 or CRV-26132)	X	2
65	NAS1149F0332P	Washer	X	2
66	NAS1149F0316P	Washer	X	2
67	MS24665-151	Cotter Pin	X	2
68	A105-7	Journal	X	1
69	U250-0185-S	Spring Washer (alternate part no. U250-0185 or CRV-26152)	X	1
70	B526-8	Screw	X	1
71	C389-13	Shim ([1] maximum per hinge)	X	A/R

NOTES * Earlier R44s.

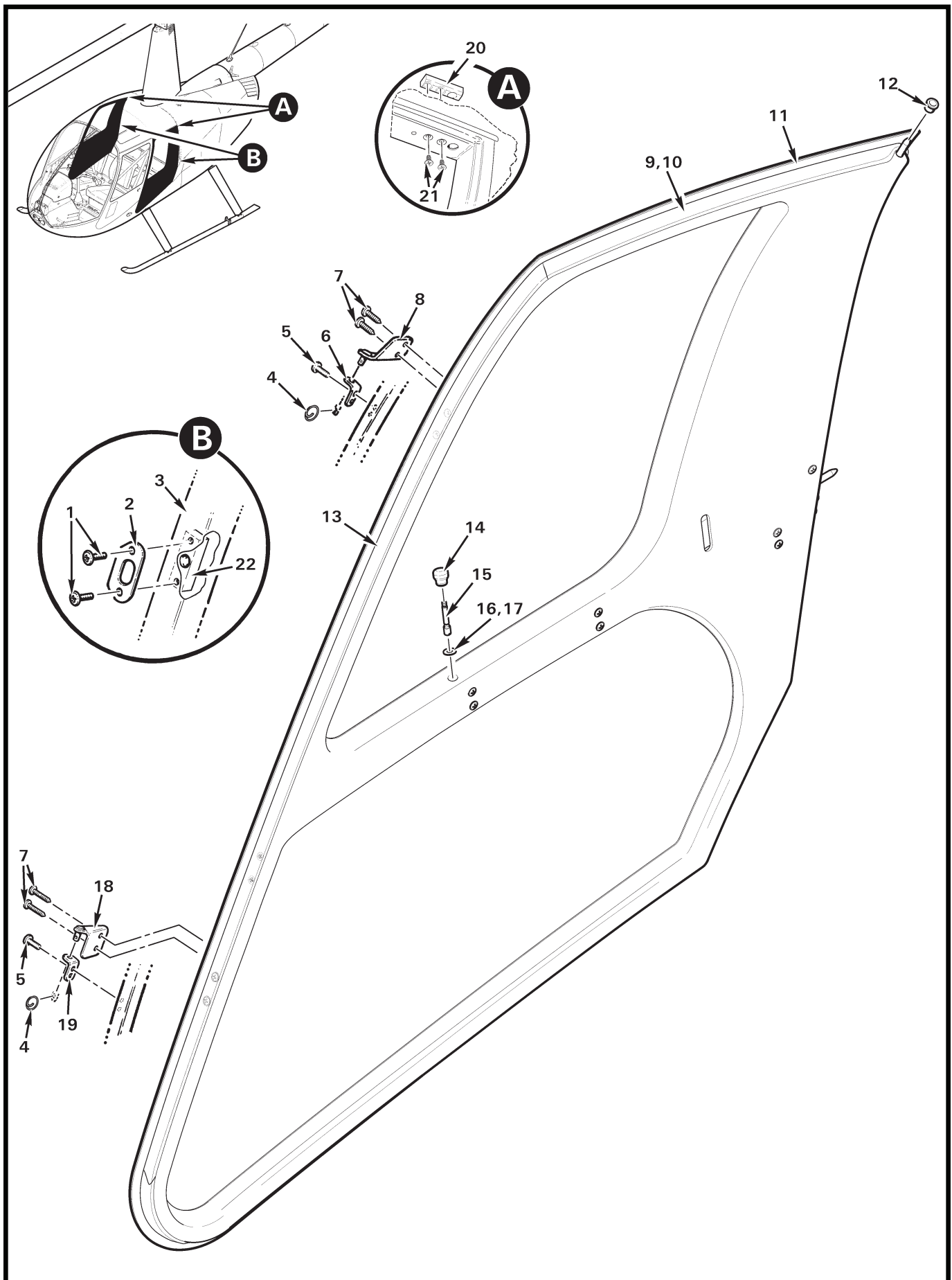

FIGURE AND INDEX NUMBER	PART NUMBER	DESCRIPTION	PARTS AVAIL	QTY PER ASSY
AFT DOOR ASSEMBLY – R44 CADET*				
52-11-1	AN525-832R6	Screw	X	2
2	C538-1	Plate	X	1
3	C238	Door Jamb (Ref)		
4	B427-1	Ring – Cotter	X	2
5	MS27039C0809	Screw	X	4
6	A228-1	Hinge	X	1
7	MS51861-37C	Screw (self-tapping)	X	4
8	C389-4	Hinge Assembly (RH, upper)	X	1
	C389-3	Hinge Assembly (LH, upper; not shown)	X	1
9	A226-2	Seal (install using item 10)	X	A/R
10	B270-18	Adhesive (5-oz. tube)	X	A/R
11	C026-224**	Door Assembly (RH, light tint; includes items 9, 13 thru 16) . . .	X	1
	C026-223**	Door Assembly (LH, light tint; includes items 9, 13 thru 16) . . .	X	1
	C026-254**	Door Assembly (RH, dark tint; includes items 9, 13 thru 16) . . .	X	1
	C026-253**	Door Assembly (LH, dark tint; includes items 9, 13 thru 16) . . .	X	1
12	2017	Bushing	X	1
	NAS557-4B	Grommet (not shown, earlier R44s)	X	1
13	A226-6	Seal (self-adhesive, front edge of door only)	X	A/R
14	A431-2	Knob (door lock)	X	1
	1770	Knob (not shown, earlier R44s)	O	1
15	C544-1	Pin	X	1
16	C26005	Washer (bond using item 17)	X	1
17	B270-9	Adhesive (2-oz. kit)	X	A/R
18	C389-10	Hinge Assembly (RH, lower)	X	1
	C389-9	Hinge Assembly (LH, lower; not shown)	X	1
19	A228-2	Hinge	X	1
20	C537-16	Block	X	2
21	93195A322	Screw	X	4
22	C537-11	Block	X	2

NOTES * Ship S/N 30001 and subsequent.
 ** Will be shipped painted white.

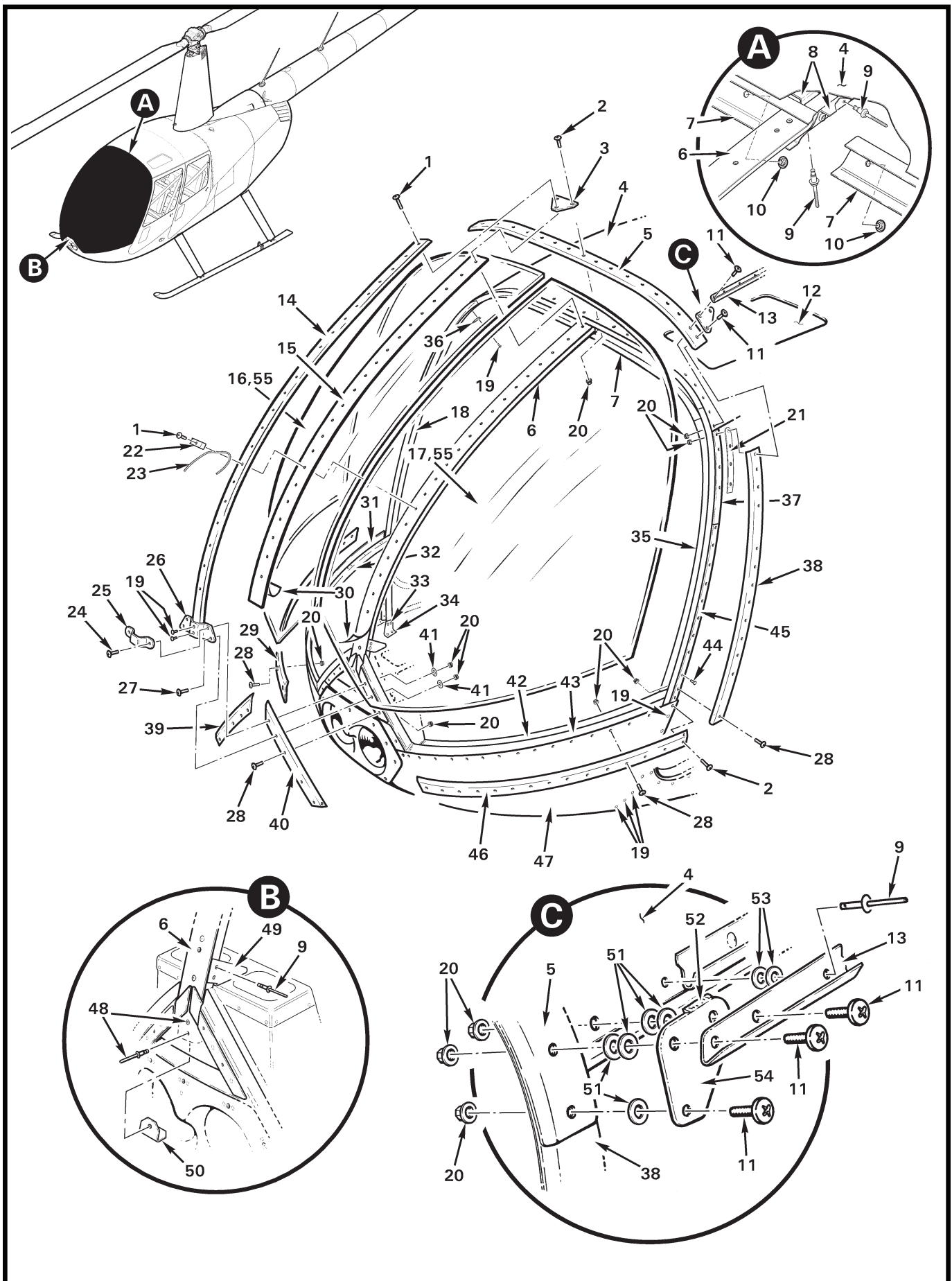

FIGURE AND INDEX NUMBER	PART NUMBER	DESCRIPTION	PARTS AVAIL	QTY PER ASSY
WINDSHIELD INSTALLATION				
52-13-1	AN526C832R12	Screw (do not substitute MS27039 screws)	X	22
2	AN526C832R9	Screw (do not substitute MS27039 screws)	X	10
3	B409-5	Gusset	X	1
4	C273-1	Roof (Incl item 12)	X	1
5	C238-29*	Retainer (apply item 52 to edges)	X	1
6	C238-2	Bow Assembly (includes wires)	X	1
7	C238-16	Frame (forward, roof)	X	1
8	C238-23	Support	X	1
9	NAS9301B-4-02	Rivet (blind; or NAS1919B04S02 as required)	X	9
10	BPF-5MM	Plug	X	8
11	AN526C832R9	Screw (or AN526C832R10 thru AN526C832R12 to obtain one thread minimum beyond nut)	X	6
12	C273-3	Window (clear acrylic)	X	1
13	C230-8*	Rain Gutter (RH, apply item 52 to edges)	X	1
	C230-7*	Rain Gutter (LH, apply item 52 to edges)	X	1
14	C367-12	Stiffener	X	1
15	C367-10*	Retainer	X	1
16	C274-2	Windshield** (RH, clear; install using item 55)	X	1
	C274-4	Windshield** (RH, tinted; install using item 55)	X	1
17	C274-1	Windshield** (LH, clear; install using item 55)	X	1
	C274-3	Windshield** (LH, tinted; install using item 55)	X	1
18	C238-4	Door Jamb (RH, forward; attach to cabin using items 25, 44, 33, and 34)	X	1
19	MS20470AD4	Rivet	X	38
20	MS21042L08	Nut	X	90
21	C396-1	Shim	X	A/R
22	B295-1	Clip (installed at 7th screw, from item 26, 8th screw with 10-hole console)	X	1
23	—	Yaw String (Ref; yarn, white acrylic, 0.10 inch dia., 3-inch length each side of clip. Source locally.)		
24	MS27039C0810	Screw	X	4
25	C366-5	Bracket	X	1
26	C366-8	Retainer	X	1
27	MS27039C0809	Screw	X	2

NOTES * Install using item 52.
 ** See Figure 99-15 for shipping crate.

Continues

FIGURE AND INDEX NUMBER	PART NUMBER	DESCRIPTION	PARTS AVAIL	QTY PER ASSY
WINDSHIELD INSTALLATION (Cont'd)				
52-13-28	AN526C832R8	Screw (do not substitute MS27039 screws)	X	78
29	C367-6*	Retainer (RH)	X	1
30	C367-11	Tape	X	A/R
31	C367-2	Retainer (RH)	X	1
32	C238-18	Frame (RH; attach with item 31 to chin [item 47] using item 44)	X	1
33	MS20470AD3	Rivet	X	8
34	A414-2	Angle (RH)	X	1
	A414-1	Angle (LH, not shown)	X	1
35	C238-3	Door Jamb (LH, forward; attach to cabin using items 25, 44, 33, and 34)	X	1
36	C211-3	Gusset	X	2
37	C238-34	Spacer (LH and RH, 0.118 in. [3mm] or 0.125 in. thick polycarbonate. Attach to items 18 and 35 using item 44.)	X	2
38	C238-27*	Retainer (LH)	X	1
	C238-28*	Retainer (RH; not shown)	X	1
39	C367-8*	Retainer (RH)	X	1
40	C367-7*	Retainer (LH)	X	1
41	NAS1149FN832P	Washer	X	4
42	C238-17	Frame (LH; attach with item 43 to chin [item 47] using item 44)	X	1
43	C367-1	Retainer (LH)	X	1
44	MS20426AD3	Rivet (flush)	X	56
45	D661-1	Spacer (LH and RH, 0.118 in. [3mm] or 0.125 in. thick polycarbonate. Attach to items 18 and 35 using item 44.)	X	2
46	C367-5*	Retainer (LH)	X	1
47	C272-1	Chin	X	1
48	NAS9301B-4-03	Rivet (blind)	X	2
49	C358-2	Support (Ref)		
50	C366-6	Cap	X	1
51	NAS1149FN832P	Washer	X	A/R
52	B270-1	Sealant	X	A/R
53	NAS620-5	Washer	X	A/R
54	D805-2	Restraint (LH and RH. Use item 52 to fill gap between items 13, 54, and 4. To retrofit earlier R44s, order item 56.)	X	2

NOTES * Earlier R44s.

Continues

FIGURE AND INDEX NUMBER	PART NUMBER	DESCRIPTION	PARTS AVAIL	QTY PER ASSY
WINDSHIELD INSTALLATION (Cont'd)				
52-13-55	B270-26	Sealant (polysulfide, 2-part, 4-oz. tube)	X	A/R
	B270-13	Sealant (silicone, 3-oz. tube)	X	A/R
		* * *		
56	KI-125	R44 Forward Door Restraint Installation Kit	X	A/R
NOTES				

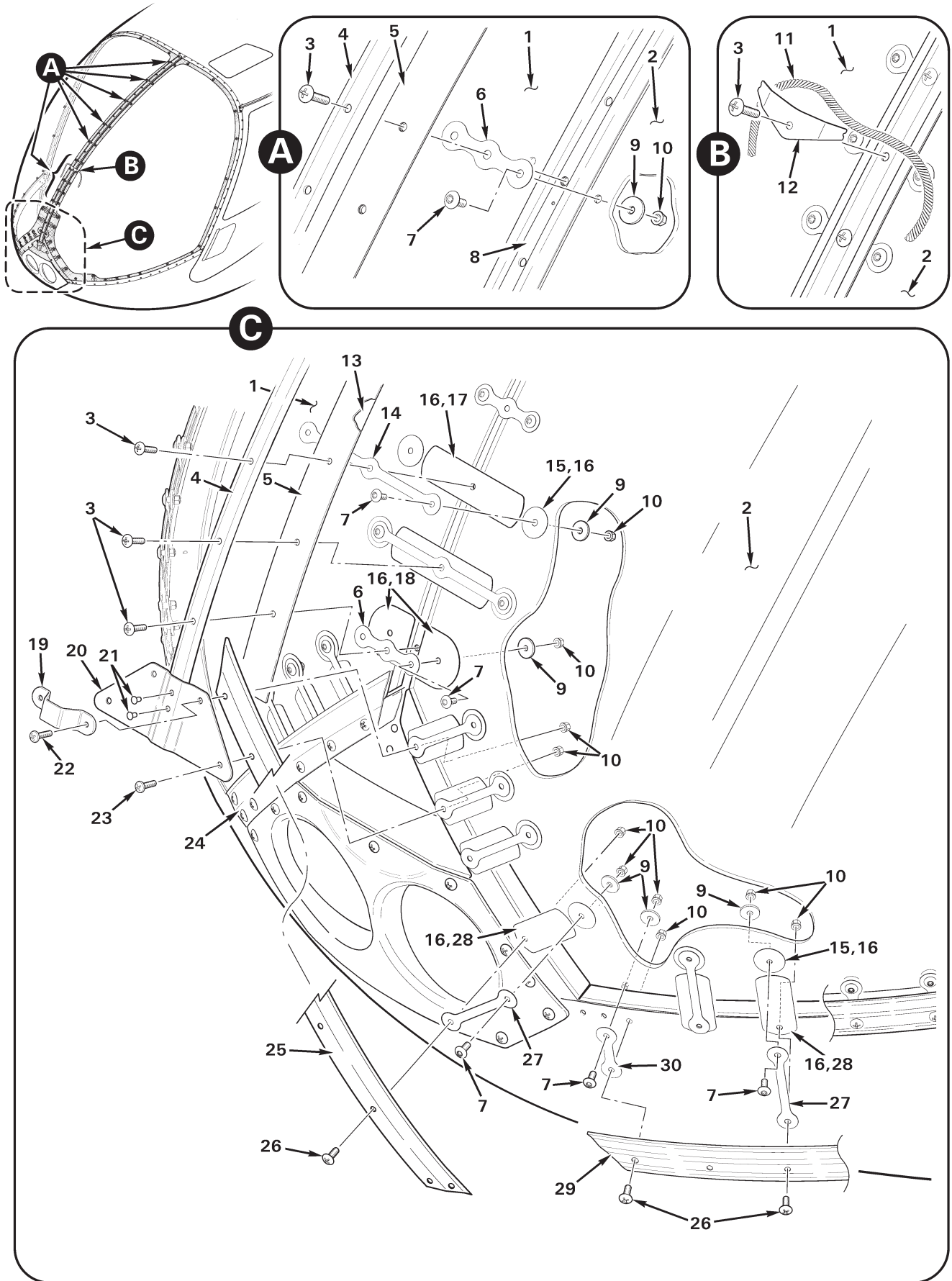

FIGURE AND INDEX NUMBER	PART NUMBER	DESCRIPTION	PARTS AVAIL	QTY PER ASSY
		WINDSHIELD INSTALLATION – IMPACT-RESISTANT (POLYCARBONATE)		
52-17-1	C274-6*	Windshield** (Polycarbonate; RH, clear. Install using item 16. Also order item 31, as required.)	X	1
	C274-8*	Windshield** (Polycarbonate; RH, tinted. Install using item 16. Also order item 31, as required.)	X	1
2	C274-5*	Windshield** (Polycarbonate; LH, clear. Install using item 16. Also order item 31, as required.)	X	1
	C274-7*	Windshield** (Polycarbonate; LH, tinted. Install using item 16. Also order item 31, as required.)	X	1
3	AN526C832R12	Screw (do not substitute MS27039 screws)	X	22
4	C367-12***	Stiffener (Ref)		
5	C367-10	Retainer (Ref)		
6	G367-2	Tie	X	12
7	B526-6	Screw (do not substitute MS27039 screws)	X	68
8	C367-9***	Retainer (Ref)		
9	C141-25	Washer	X	68
10	MS21042L08	Nut	X	68
11	–	Yaw String (Ref; yarn, white acrylic, source locally. 0.10-inch dia., 3-inch length each side of clip.)		
12	B295-2	Clip – Yaw String (install 7th screw from bottom)	X	1
13	C367-11***	Tape (Ref)		
14	G367-11	Tie	X	2
15	G367-15*	Pad	X	16
16	B270-26	Sealant (polysulfide, 2-part 4-oz. tube)	X	A/R
17	G367-13*	Tab	X	2
18	G367-14*	Pad	X	2
19	C366-5***	Bracket (Ref)		
20	C366-8***	Retainer (Ref)		
21	MS20470AD4***	Rivet (Ref)		
22	MS27039C0810***	Screw (Ref)		
23	MS27039C0809	Screw	X	2
24	C367-8***	Retainer (RH, Ref)		
25	C367-7***	Retainer (LH, Ref)		
26	AN526C832R8	Screw (Ref)		
27	G367-10	Strap	X	12
28	G367-12*	Tab	X	12

NOTES * Refer to R44 MM § 27-32 for replacement procedures.
 ** See Figure 99-15 for shipping box.
 *** See Figure 52-15.

Continues

FIGURE AND INDEX NUMBER	PART NUMBER	DESCRIPTION	PARTS AVAIL	QTY PER ASSY
WINDSHIELD INSTALLATION – IMPACT-RESISTANT (POLYCARBONATE) (Cont'd)				
52-17-29	C367-5*	Retainer (LH, Ref)		
	C367-6*	Retainer (RH, Ref)		
30	G367-1	Strap	X	28
31	MT084-1.CS	Paint Templates – Sheet (Apply trim paint using paint templates per R44 MM § 27-32 Part G when replacing windshield[s] or if otherwise required. One sheet accommodates layout for two RH & two LH windshields. For use with R22-series, R44-series, and R66 helicopters equipped with polycarbonate windshields. Not shown.)	X	A/R

NOTES * See Figure 52-15.

Intentionally Blank

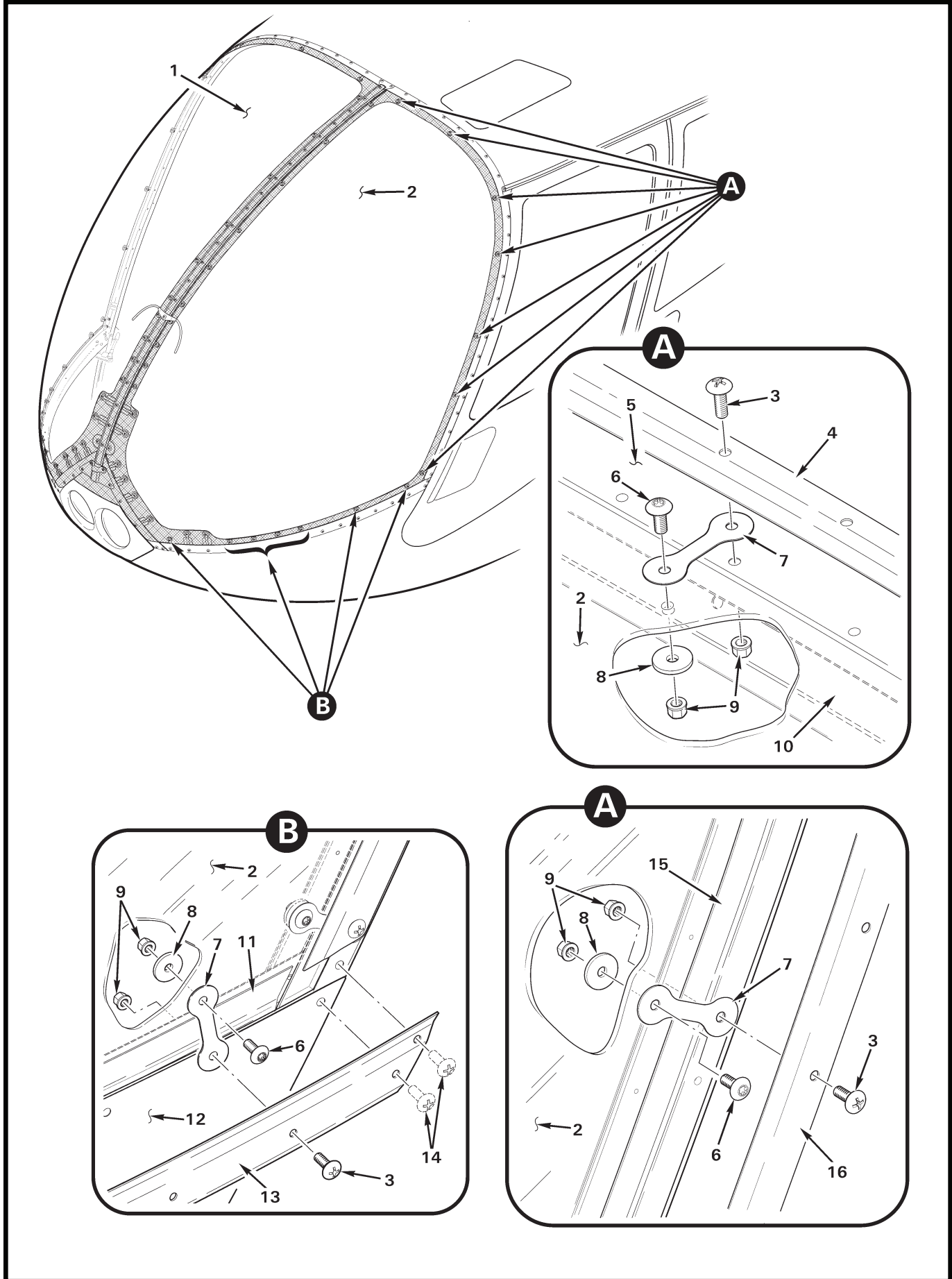

FIGURE AND INDEX NUMBER	PART NUMBER	DESCRIPTION	PARTS AVAIL	QTY PER ASSY
		WINDSHIELD INSTALLATION – IMPACT-RESISTANT (POLYCARBONATE)		
52-21-1	C274-6*	Windshield (Ref; Polycarbonate; RH, clear)		
	C274-8*	Windshield (Ref; Polycarbonate; LH, clear)		
2	C274-5*	Windshield (Ref; Polycarbonate; RH, tinted)		
	C274-7*	Windshield (Ref; Polycarbonate; LH, tinted)		
3	AN526C832R8	Screw (do not substitute MS27039 screws)	X	60
4	C238-29**	Retainer (Ref)		
5	C273-1**	Roof (Ref)		
6	B526-6	Screw (do not substitute MS27039 screws)	X	68
7	G367-1	Strap	X	28
8	C141-25	Washer	X	68
9	MS21042L08	Nut	X	68
10	C238-16**	Frame (forward, roof; Ref)		
11	C367-1**	Retainer (LH, Ref)		
	C367-2**	Retainer (RH, Ref)		
12	C272-1**	Chin (Ref)		
13	C367-5**	Retainer (LH, Ref)		
	C367-6**	Retainer (RH, not shown; Ref)		
14	AN526832R9**	Screw (Ref)		
15	C238-3**	Door Jamb (LH, Ref)		
16	C238-27**	Retainer (LH, Ref)		
	C238-28**	Retainer (RH, Ref)		

NOTES * See Figure 52-19.
 ** See Figure 52-15.

Intentionally Blank

CHAPTER 53

FUSELAGE

<i>Figure</i>	<i>Title</i>	<i>Page</i>
53-1	Side Cowling Assemblies	53.0
53-5	Aft Cowling Assembly	53.4
53-9	Aft Cowling Assembly – Slats Installation	53.8
53-11	Mast Fairing Assembly	53.10
53-13	Tailcone Cowling Assembly	53.12
53-15	Main Gearbox Compartment Access Doors and Cowling	53.14
53-19	Frame Assemblies	53.18
53-23	Frame Assemblies	53.22
53-25	Tailcone Assembly (LED Strobe)	53.24
53-29	Tailcone Assembly (LED Strobe)	53.28
53-33	Tailcone Assembly	53.32
53-37	F004-2 Empennage Assembly	53.36
53-41	C004-2 Empennage Assembly	53.40
53-45	F050-2 Horizontal Stabilizer Installation	53.44
53-47	C050-2 Float Stabilizer Installation	53.46
53-49	Wind Deflector Installation	53.48
53-51	Lower Console Assembly	53.50

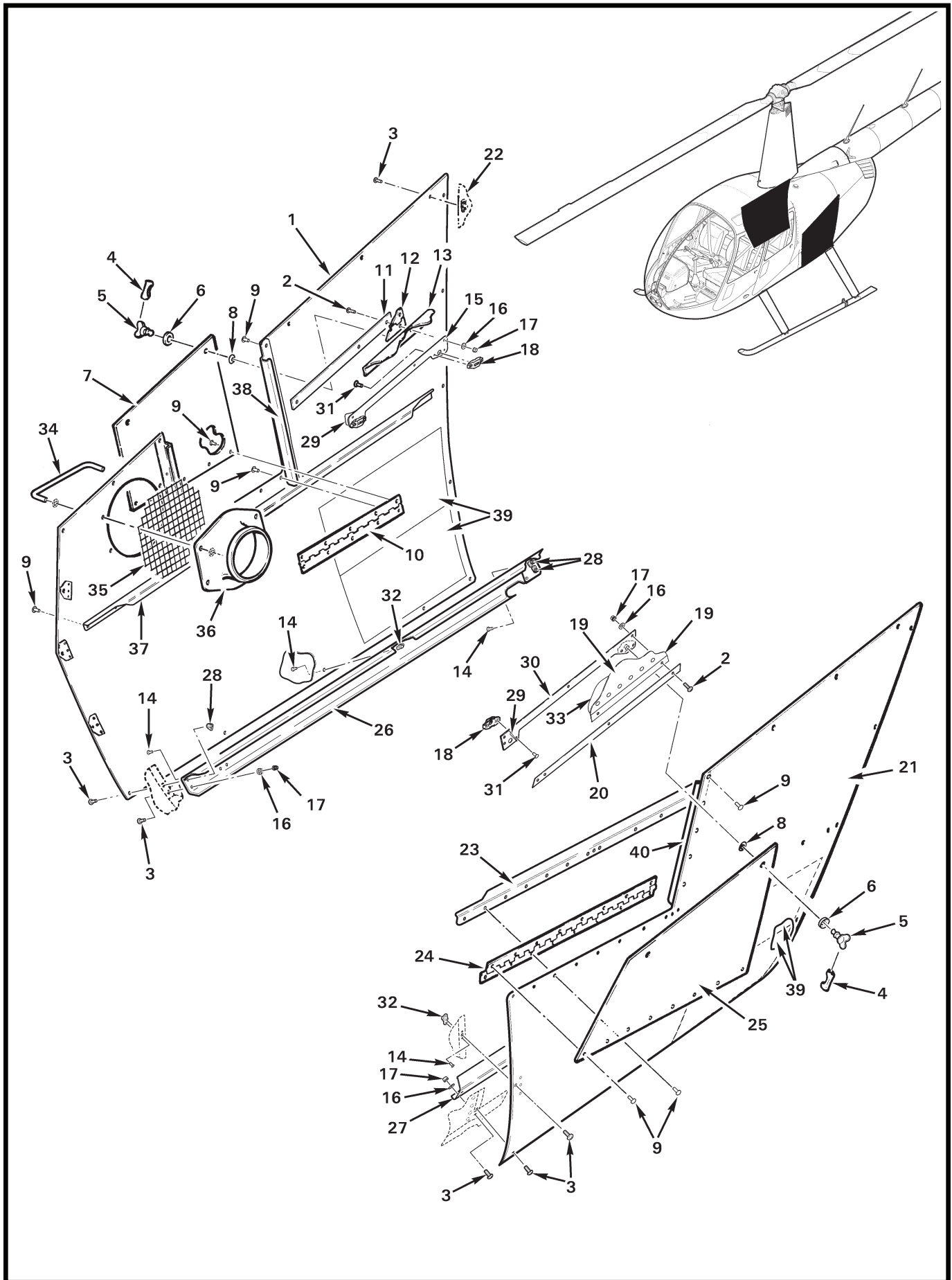

FIGURE AND INDEX NUMBER	PART NUMBER	DESCRIPTION	PARTS AVAIL	QTY PER ASSY
SIDE COWLING ASSEMBLIES				
53-1-1	C378-3.CS*	Cowling Assembly (RH, includes items 7, 9 [28], and 10. C378-3* supersedes C378-1. To replace C378-1, also order items 34 thru 36.)	X	1
	C378-1**	Cowling Assembly (RH; no longer available)	O	1
2	MS27039C0807	Screw ([3] for RH, [4] for LH)	X	7
3	MS27039C0806	Screw ([22] for RH, [21] for LH)	X	43
4	A901-1	Cover (clear plastic)	X	2
5	85-12-140-16	Stud	X	4
6	85-46-101-39	Washer	X	4
7	C364-7	Door	X	1
8	85-34-201-20	Retaining Ring	X	4
9	MS20470AD3	Rivet	X	7
10	C364-3	Hinge	X	1
11	C364-6	Strip (RH)	X	1
12	D315-4	Hinge (Ref, see Figure 53-15)		
13	D021-1	Firewall Assembly, Horizontal (Ref)		
14	MS20426AD3	Rivet	X	40
15	C364-4	Receptacle Assembly (RH, includes items 18 and 31)	X	1
16	NAS1149FN816P	Washer	X	11
17	MS21042L08	Nut ([3] on RH, [4] on LH)	X	11
18	85-35-295-15	Receptacle (install using item 31)	X	2
19	C010	Main Fuel Tank Assembly (Ref, see Figure 28-1)		
20	C380-7	Strip (LH)	X	1
21	C377-1.CS	Cowling Assembly (LH, includes items 9 [28], 23 thru 25, 38, and 39. Comes painted white.)	X	1
22	D040	Aft Cowling Assembly (Ref)		
23	C380-3	Stiffener	X	1
24	C380-6	Hinge	X	1
25	C380-5	Door	X	1
26	C387-2	Channel Assembly (RH, includes items 14 [4] and 28 [2])	X	1
27	C387-1	Channel Assembly (LH, includes items 14 [4] and 28 [2])	X	1
28	MS21086L08	Nutplate (install using item 14)	X	2
29	A701-3	Tape (0.5 in. wide polyethylene)	X	A/R
30	C380-1	Receptacle Assembly (LH, includes items 18 and 31)	X	1
31	NAS1097AD4	Rivet	X	4
32	MS21069L08	Nutplate (install using item 14)	X	18

NOTES * Ship S/N 1301 and subsequent, 10001 and subsequent. Comes painted white. Additional charges for color matching.

** Ship S/N 0001 thru 1300 only.

Continues

FIGURE AND INDEX NUMBER	PART NUMBER	DESCRIPTION	PARTS AVAIL	QTY PER ASSY
SIDE COWLING ASSEMBLIES (Cont'd)				
53-1-33	C234-1	Firewall (Ref, LH fwd horizontal)		
34	A580-3	Guard (large inlet, Ref)		
35	A640-4*	Screen (Ref)		
36	C579-3*	Inlet (large hole, Ref)		
37	C364-8	Stiffener	X	1
38	C364-2	Stiffener	X	1
39	A701-2	Tape – Aluminum (6-inch width)	X	A/R
40	C380-4	Stiffener	X	1

NOTES * O-540 equipped ships only. See Figure 71-17.

Intentionally Blank

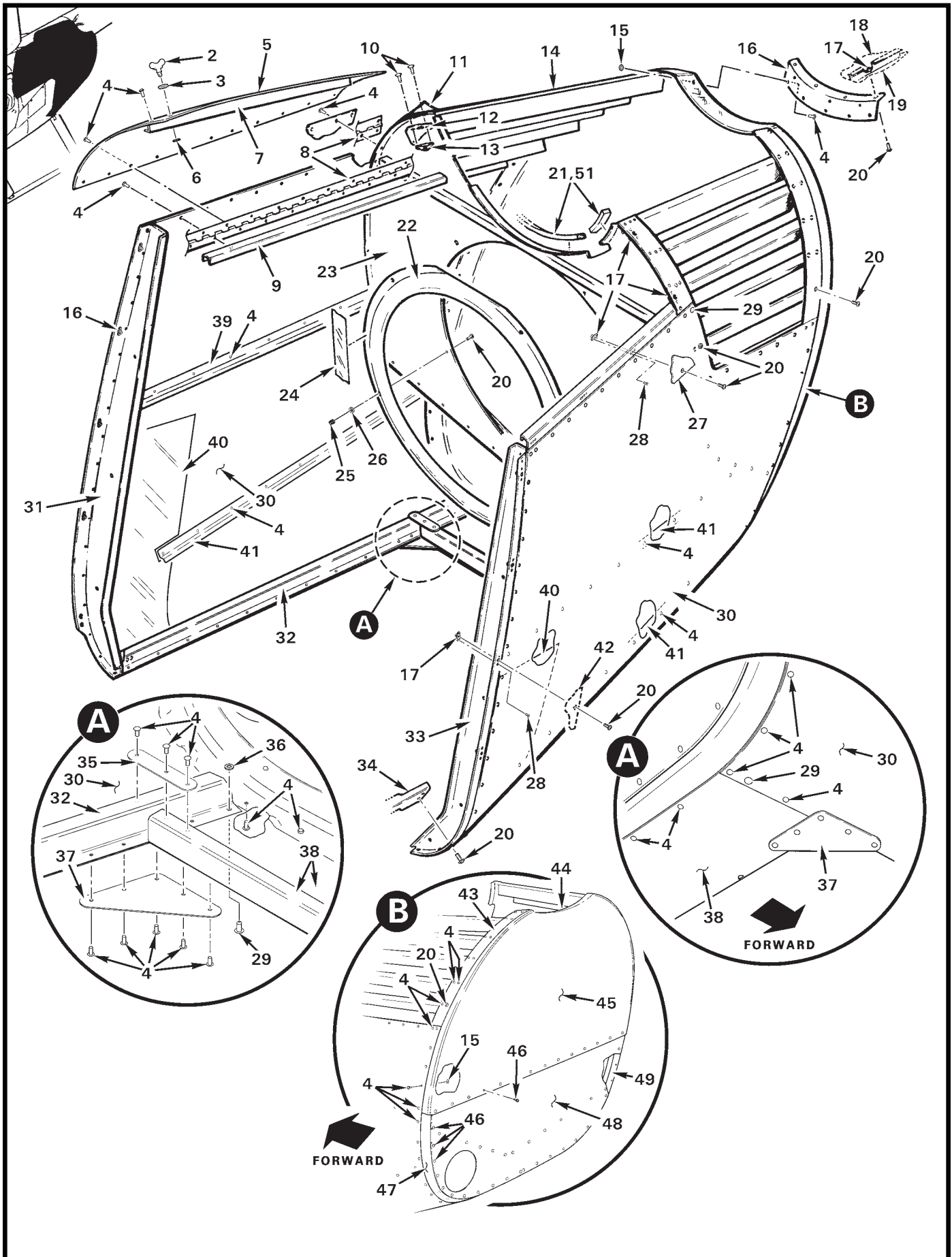

FIGURE AND INDEX NUMBER	PART NUMBER	DESCRIPTION	PARTS AVAIL	QTY PER ASSY
AFT COWLING ASSEMBLY				
53-5-1	D040-1	Cowling Assembly – Aft (Incl items 5, 7 thru 10, 12, 13, 15, 20, 21, 39, 40, 41, 43, and 44.)	X	1
2	85-12-140-16	Stud	X	2
3	85-46-101-39	Washer	X	2
4	MS20470AD3	Rivet	X	205
5	D040-7	Door	X	1
6	85-34-201-20	Retaining Ring	X	2
7	D308-6	Stiffener	X	1
8	D308-5	Hinge	X	1
9	D311-8	Stiffener	X	1
10	MS20426AD4	Rivet	X	2
11	A701-3	Tape (0.5 in. wide polyethylene)	X	A/R
12	D308-8	Plate	X	1
13	85-35-295-15	Receptacle	X	1
14	D307	Slat Installation (Ref, see Figure 53-9)		
15	NAS1149FN232P	Washer	X	19
16	D300-1	Support	X	1
	D300-2	Support (undrilled upper flange, use when installing new item 1 with a previously drilled tailcone)	X	A/R
17	MS21069L08	Nutplate (install using item 28)	X	13
18	D083-2	Stiffener (Ref)	O	1
19	C023	Tailcone Assembly (Ref, includes items 17 and 18)		
20	MS27039C0806	Screw	X	2
21	A226-4	Seal (self-adhesive)	X	A/R
22	D306-3	Ring	X	1
23	D306-2	Bulkhead	X	1
24	A701-1	Foil Tape (one-inch width; around ring)	X	A/R
25	MS21042L08	Nut	X	4
26	NAS1149FN816P	Washer	X	4
27	C706-3	Panel (Ref, see Figure 53-13)		
28	MS20426AD3	Rivet	X	44
29	MS20470AD4	Rivet	X	4
30	D040-3	Skin (RH and LH)	X	2
31	D305-2	Frame (RH)	X	1
32	D311-2	Stiffener (RH and LH [not shown])	X	2

NOTES

Continues

FIGURE AND INDEX NUMBER	PART NUMBER	DESCRIPTION	PARTS AVAIL	QTY PER ASSY
AFT COWLING ASSEMBLY (Cont'd)				
53-5-33	D305-1	Frame (LH)	X	1
34	C387-1	C387-1 Channel Assembly (LH, Ref; see Figure 53-1)		
35	D311-4	Tab (RH and LH [not shown])	X	2
36	NAS620-5	Washer	X	2
37	D311-3	Gusset (RH and LH [not shown])	X	2
38	D311-1	Panel	X	1
39	D308-3	Stiffener (RH only)	X	1
40	A701-2	Foil Tape (six-inch width)	X	A/R
41	D308-3	Stiffener (LH [2] and RH [1])	X	3
42	C377-1	Cowling Assembly (Ref, see Figure 53-1)		
43	D308-1	Strip (LH and RH)	X	2
44	D038-1	Cover Assembly – Aft Cowling (Incl items 45 thru 50)	X	1
45	D038-2	Cover (fiberglass)	X	1
46	MS20470AD3	Rivet	X	36
47	D038-3*	Flange (LH)	X	1
48	D038-5*	Panel (aluminum)	X	1
49	D038-4*	Flange (RH)	X	1
50	B270-1	Sealant	X	A/R
51	B270-8qt	Adhesive	X	A/R

NOTES * Install using item 50 to seal edges.

Intentionally Blank

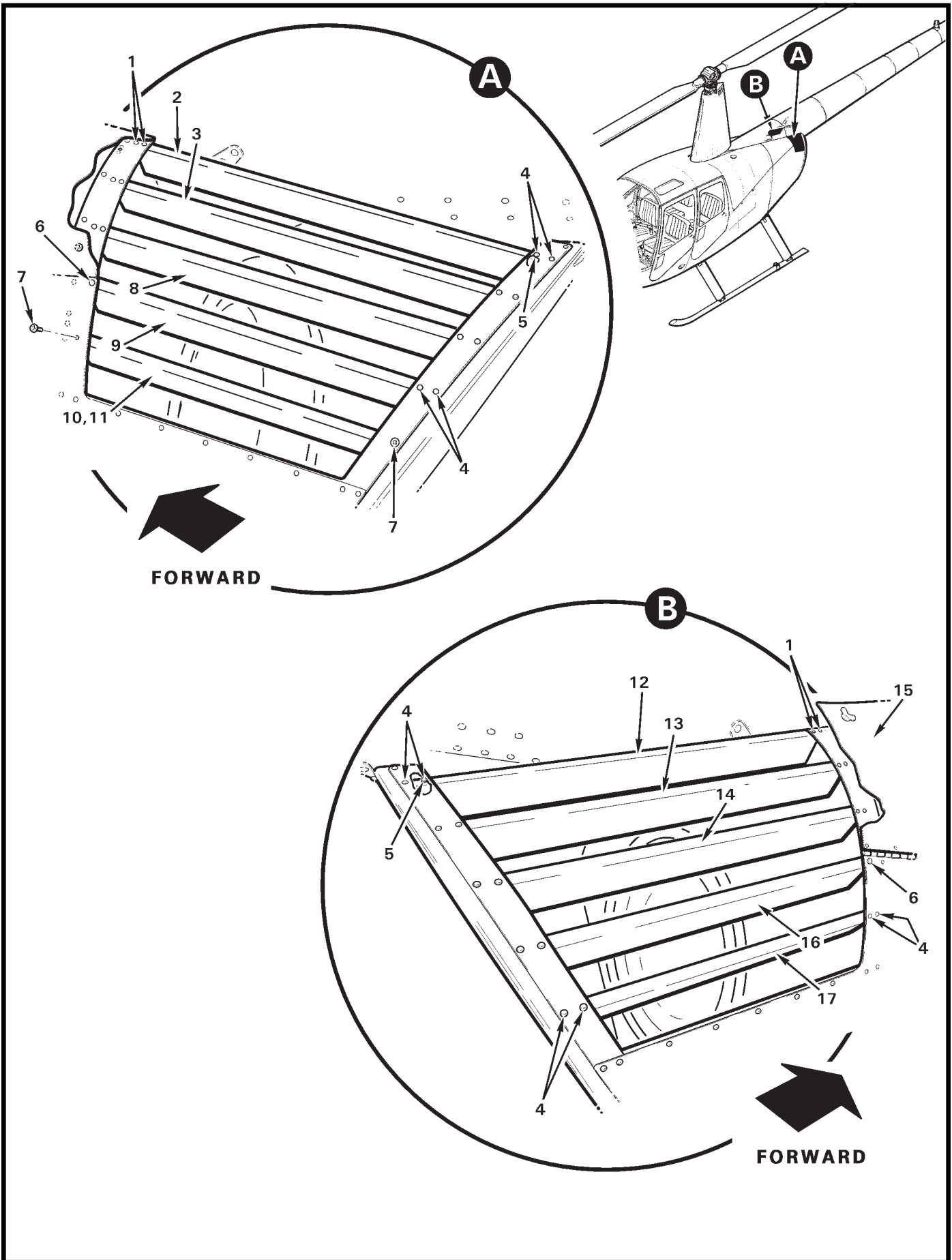

FIGURE AND INDEX NUMBER	PART NUMBER	DESCRIPTION	PARTS AVAIL	QTY PER ASSY
AFT COWLING ASSEMBLY – SLATS INSTALLATION				
53-9-1	MS20426AD3	Rivet	X	A/R
2	D307-1	Slat (LH)	X	1
3	D307-3	Slat (LH)	X	1
4	MS20470AD3	Rivet	X	20
5	NAS1149FN232P	Washer	X	A/R
6	MS20470AD4	Rivet	X	2
7	MS27039C0806	Screw	X	2
8	D307-5	Slat (LH)	X	1
9	D307-7	Slat Assembly (LH)	X	1
10	D307-11	Slat Assembly (LH; includes item 11)	X	1
11	MS21071L08K	Nutplate (not shown; install using item 1)	X	2
12	D307-2	Slat (RH)	X	1
13	D307-4	Slat (RH)	X	1
14	D307-6	Slat (RH)	X	1
15	D040-7	Door (Ref)		
16	D307-8	Slat (RH)	X	1
17	D307-10	Slat (RH)	X	1
NOTES				

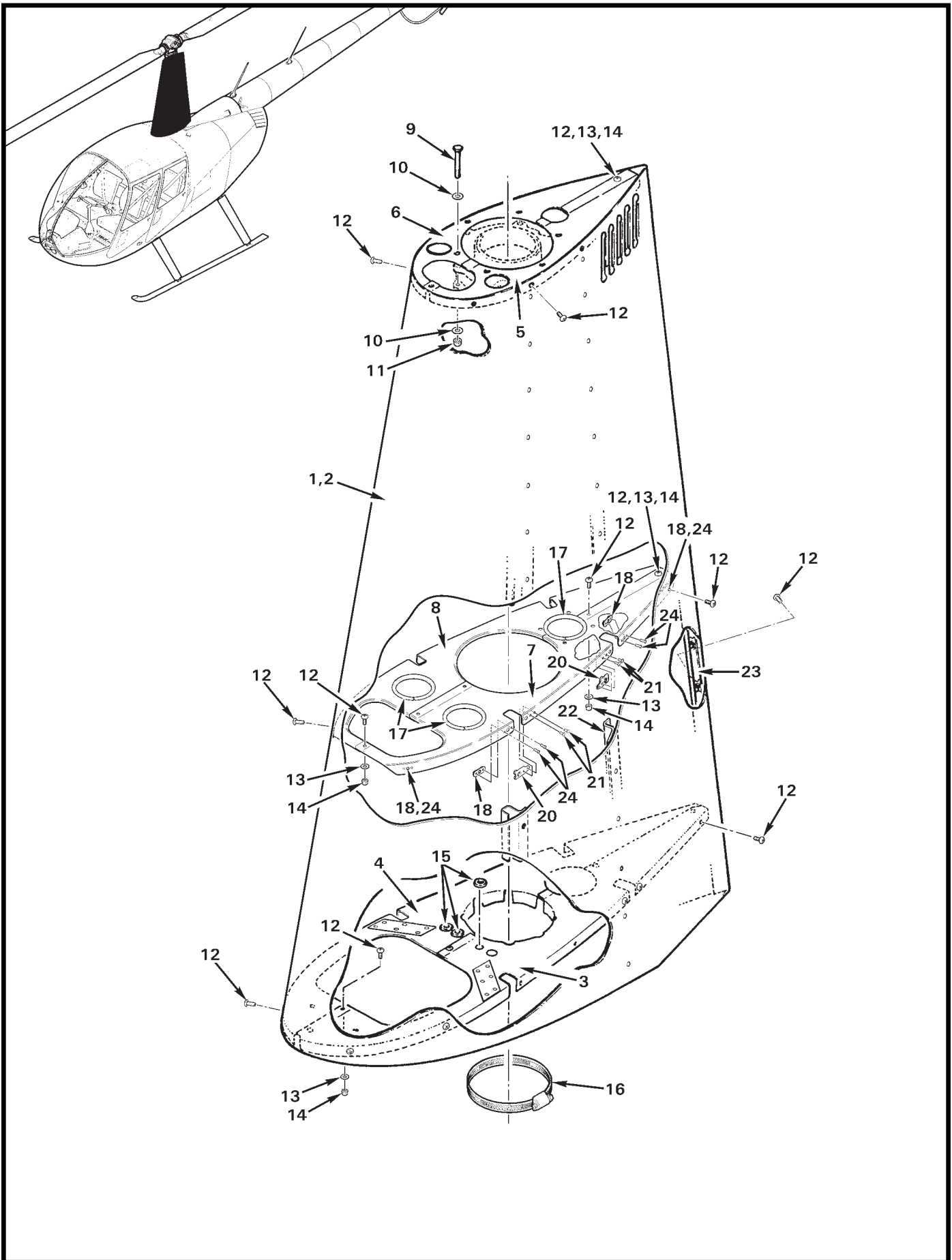

FIGURE AND INDEX NUMBER	PART NUMBER	DESCRIPTION	PARTS AVAIL	QTY PER ASSY
MAST FAIRING ASSEMBLY				
53-11-1	C261-11.CS*	Mast Fairing Assembly – Large Mast (for use with C006-7 MRGB)	X	1
	C261-1.CS*	Mast Fairing Assembly – Small Mast (Incl items 2 thru 8, and 12 thru 23; for use with C006-3, or C006-5 MRGB)	X	1
2	C261-12	Skin Assembly (Incl 19, 22, 23, and MS20605R3W2 rivet) . . .	O	1
3	C261-13	Rib Assembly – Lower (LH, small mast)	X	1
	C261-19	Rib Assembly – Lower (LH, large mast)	X	1
4	C261-14	Rib Assembly – Lower (RH, small mast)	X	1
	C261-20	Rib Assembly – Lower (RH, large mast)	X	1
5	C261-15	Rib – Upper (LH)	X	1
6	C261-16	Rib – Upper (RH)	X	1
7	C261-17	Rib – Middle (LH)	X	1
8	C261-18	Rib – Middle (RH)	X	1
9	NAS6603-24	Bolt	X	4
	NAS6603-40	Bolt	X	2
10	NAS1149F0332P	Washer	X	12
11	D210-3	Nut	X	6
12	MS27039C0806	Screw	X	54
13	NAS1149FN816P	Washer	X	10
14	MS21042L08	Nut	X	10
15	MS35489-6	Grommet	X	3
16	B277-064	Clamp (small mast)	X	1
	B277-072	Clamp (large mast)	X	1
17	NAS557-28A	Grommet	X	3
18	MS21075L08E	Nutplate	X	26
19	C395-3	Stiffener (forward)	X	2
20	MS21061L08K	Nutplate	X	12
21	MS20426AD3	Rivets	X	68
22	C395-4	Stiffener (aft)	X	2
23	A738-16	Gang Channel	X	1
24	NAS1097AD3	Rivet	X	A/R

NOTES * Comes painted white. Additional charges for color matching.

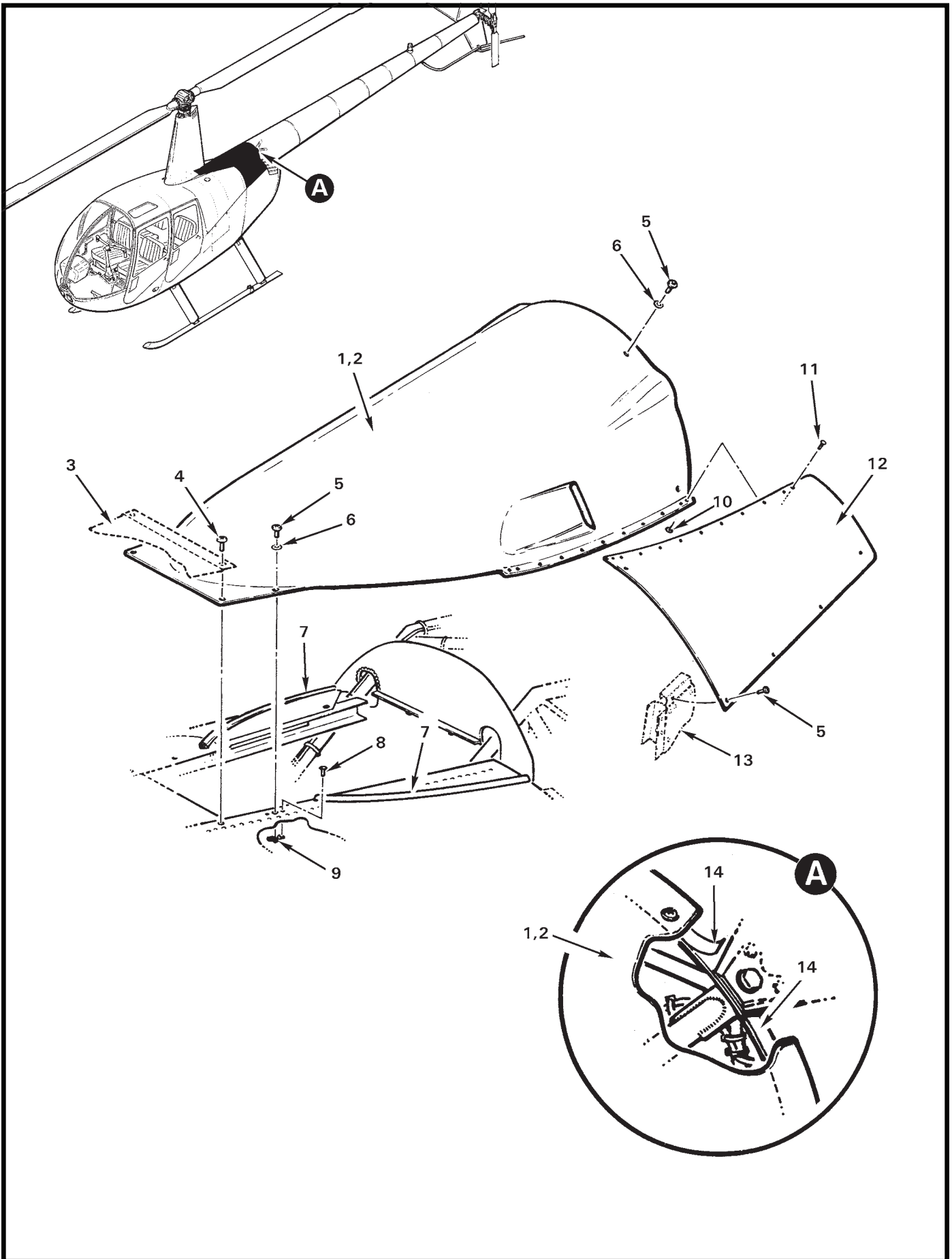

FIGURE AND INDEX NUMBER	PART NUMBER	DESCRIPTION	PARTS AVAIL	QTY PER ASSY
TAILCONE COWLING ASSEMBLY				
53-13-1	C706-1 *	Tailcone Cowling Assembly (Incl items 2, and 10 thru 12)	O	1
2	C706-2	Cowling	X	1
3	C347-6	Panel (Ref, see Figure 53-15)		
4	MS27039C0807	Screw	X	2
5	MS27039C0806	Screw	X	12
6	NAS1149FN816P	Washer	X	6
7	A226-13	Seal (LH and RH, 20 in. per side, self-adhesive)	X	A/R
8	MS20426AD3	Rivet	X	4
9	MS21069L08	Nutplate	X	2
10	NAS1149FN232P	Washer	X	9
11	MS20470AD3-4	Rivet	X	9
12	C706-3	Panel	X	1
13	D040-1	Aft Cowling Assembly (Ref, see Figure 53-5)		
14	A701-3	Tape (0.5-inch wide polyethylene)	X	A/R

NOTES * To replace order items 2, 12, [11] 10, and [11] 11. Comes painted white. Additional charges for paint matching.

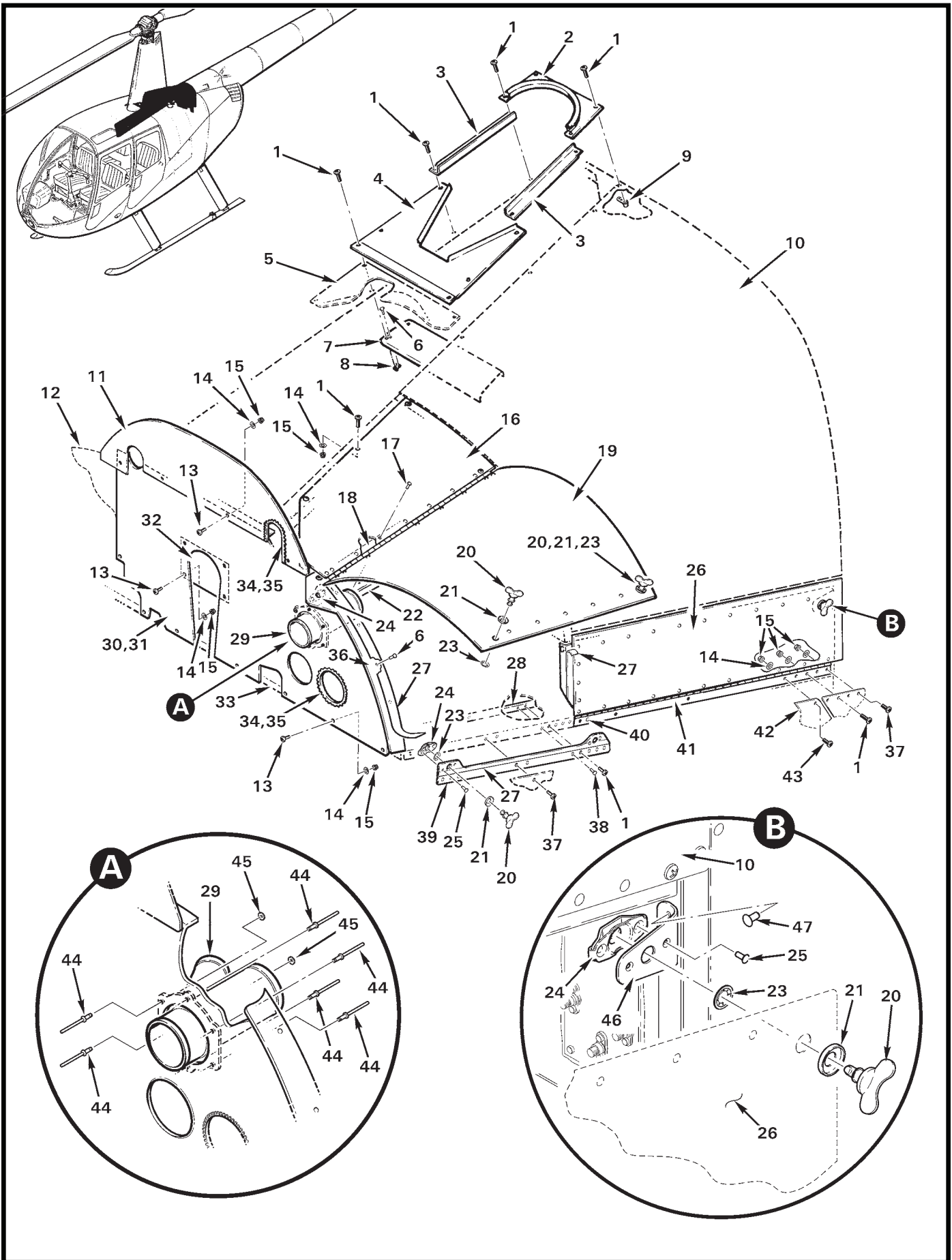

FIGURE AND INDEX NUMBER	PART NUMBER	DESCRIPTION	PARTS AVAIL	QTY PER ASSY
		MAIN GEARBOX COMPARTMENT ACCESS DOORS AND COWLING		
53-15-1	MS27039C0807	Screw	X	17
2	C347-1	Channel Assembly	X	1
3	C347-5	Angle (LH and RH)	X	2
4	C347-6	Panel	X	1
5	C706-1	Tailcone Cowling Assembly (Ref, see Figure 53-13)		
6	MS20426AD3	Rivet	X	10
7	D202-1	Channel	X	1
8	MS21086L08	Nutplate (install using item 6)	X	4
9	MS21071L08	Nutplate (install using item 6)	X	1
10	D043-3	Fuel Tank – Aux (Ref, see Figure 28-5)		
11	C723-2	Bulkhead Assembly (Incl item 34)	X	1
12	C028	Fuel Tank – Main (Ref, see Figure 28-1)		
13	MS27039C0805	Screw	X	16
14	NAS1149FN832P	Washer	X	22
15	MS21042L08	Nut	X	22
16	D042-3	Panel	X	1
17	MS20470AD3	Rivet	X	27
18	D315-3	Hinge	X	1
19	D042-5*	Door Assembly (Includes D042-2 door, D315-1 angle [not shown], and items 16, 18, and 22.)	X	1
20	85-12-140-16	Stud	X	3
21	85-46-101-39	Washer	X	3
22	D315-2	Channel	X	1
23	85-34-201-20	Retaining Ring	X	3
24	85-35-295-15	Receptacle (install using item 25)	X	3
25	NAS1097AD4	Rivet	X	6
26	D042-4*	Door Assembly	X	1
27	A701-3	Tape (0.5 in. wide polyethylene)	X	A/R
28	A738-11	Gang Channel (RH)	X	1
	A738-23	Gang Channel (LH, not shown)	X	1
29	C371-1	Splitter – Air Duct	X	1
30	C723-1	Bulkhead Assembly (Incl items 24, 29, 31, 34 thru 36, 44, and 45)	X	1
31	C723-3	Bulkhead – Lower	O	1
32	C723-6	Cover	X	1

NOTES * Comes painted white. Additional charges for color matching.

Continues

FIGURE AND INDEX NUMBER	PART NUMBER	DESCRIPTION	PARTS AVAIL	QTY PER ASSY
MAIN GEARBOX COMPARTMENT ACCESS DOORS AND COWLING (Cont'd)				
53-15-33	C234-2	Firewall – Horizontal (Ref)		
34	MS21266-1N	Grommet (install using item 35)	X	A/R
35	B270-8qt	Adhesive (1-quart can)	X	A/R
36	C723-5	Strip	O	1
37	MS27039C0806	Screw (Ref, see Figure 53-1)		
38	MS20427M3	Rivet (use to install item 39; [13] req'd RH, [4] req'd LH)	X	A/R
39	C379-1	Receptacle Assembly (RH, includes items 24 and 25)	X	1
	C380-1	Receptacle Assembly (LH not shown, includes items 24 & 25)	X	1
40	MS20427M3	Rivet ([1] at this location)	X	1
41	D315-4	Hinge	X	1
42	C378*	Cowling Assembly (Ref; RH shown)		
43	MS20739C0806*	Screw (Ref)		
44	MS20604R3W3	Rivet (supersedes NAS9301B-4-02)	X	6
45	NAS1149FN232P	Washer (supersedes NAS620-5)	X	2
46	C379-2	Receptacle Assembly (includes angle and items 24 and 25)	X	1
47	MS204470AD4	Rivet	X	2

NOTES * See Figure 53-1.

Intentionally Blank

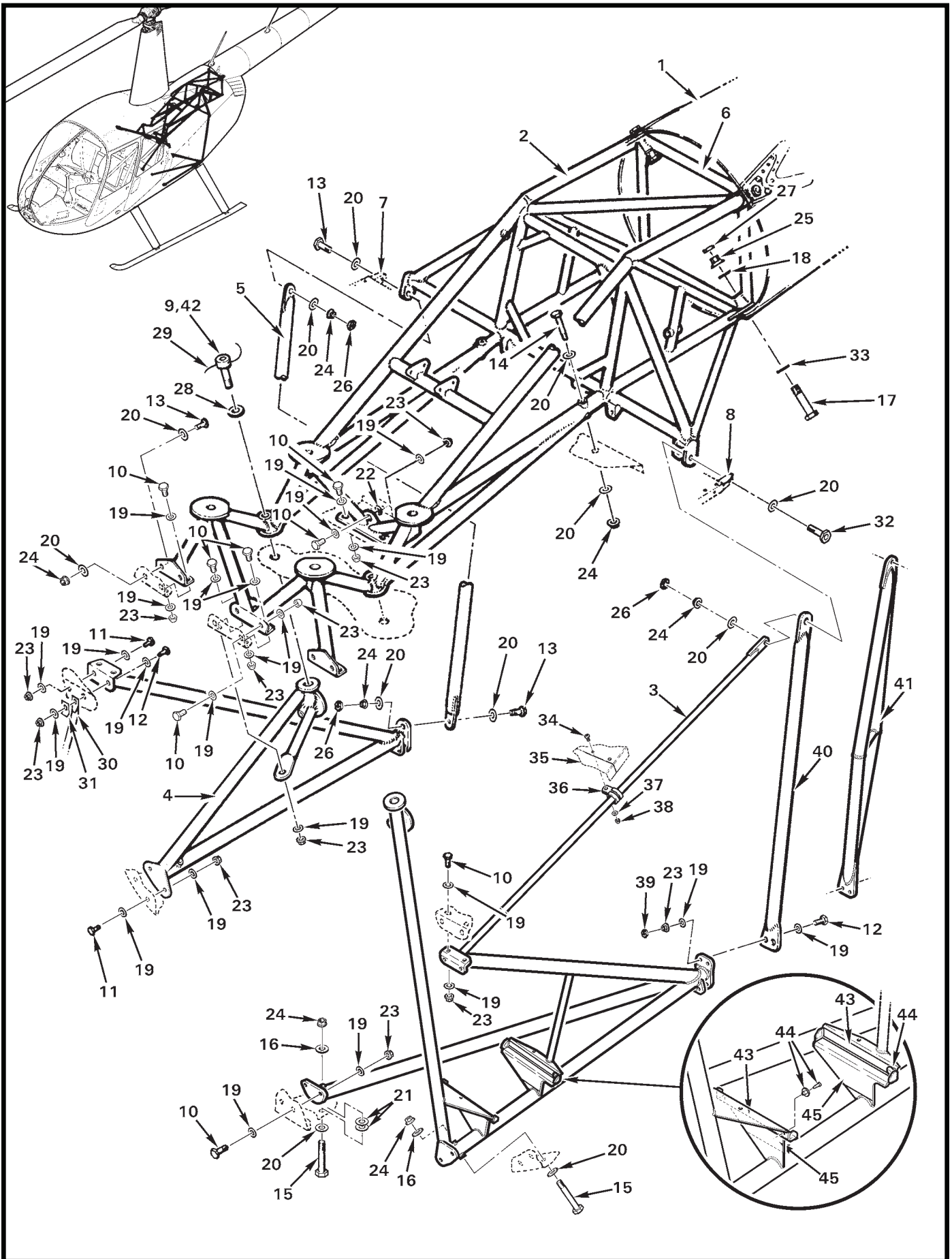

FIGURE AND INDEX NUMBER	PART NUMBER	DESCRIPTION	PARTS AVAIL	QTY PER ASSY
FRAME ASSEMBLIES				
53-19-1	C023	Tailcone Assembly (Ref)		
2	C020-1	Upper Frame Assembly	X	1
	C020-2	Upper Frame Assembly (Ref, not shown. Includes provision for tie-downs.)	X	1
3	C046-23	Lower Frame Assembly – LH (R44 Raven I [28 V], R44 Raven II. See Figure 53-23 for earlier R44s.)	X	1
4	C046-2	Lower Frame Assembly – RH	X	1
5	D046-3	Strut Weldment – RH	X	1
6	C237-1	Frame Assembly – Tailcone Attachment	X	1
7	C384-6	Angle – RH	X	1
8	C384-7	Angle – LH	X	1
9	C722-2	Bolt (install using item 42)	X	2
10	NAS6604-2	Bolt	X	17
11	NAS6604-3	Bolt	X	6
12	NAS6604-4	Bolt	X	4
13	NAS6605-4	Bolt	X	6
14	NAS6605-21	Bolt	X	2
15	NAS6605-24	Bolt	X	3
16	NAS1149F0563P	Washer	X	2
17	NAS6607-24	Bolt	X	4
18	C141-4	Washer	X	4
19	NAS1149F0432P	Washer	X	54
20	NAS1149F0532P	Washer	X	24
21	NAS1149F0532P	Washer (or NAS1149F0563P, 2 maximum)	X	A/R
22	NAS1149F0432P	Washer (or NAS1149F0463P, 2 maximum)	X	A/R
23	D210-4	Nut	X	27
24	D210-5	Nut	X	12
25	D210-7	Nut	X	4
26	B330-16	Palnut	X	3
27	B330-21	Palnut	X	4
28	MS21299C10K	Washer	X	2
29	MS20995C32	0.032 in. dia. Safety Wire	X	A/R
30	C381-1	Strap Assembly (Ref; see Figure 25-5)		
31	C632-1	Angle (Ref; see Figure 25-5)	X	2
32	NAS6605-6	Bolt	X	1

NOTES

Continues

FIGURE AND INDEX NUMBER	PART NUMBER	DESCRIPTION	PARTS AVAIL	QTY PER ASSY
FRAME ASSEMBLIES (Cont'd)				
53-19-33	NAS1149F0732P	Washer	X	4
34	MS27039C0806	Screw	X	1
35	C234	Firewall – Horizontal (Ref)		
36	NAS1715C8SW	Clamp	X	1
37	NAS1149FN816P	Washer	X	1
38	MS21042L08	Nut	X	1
39	B330-13	Palnut	X	2
40	D046-2	Strut Weldment (LH, O-540 engine)	X	1
41	D046-1	Strut Weldment (LH, IO-540 engine)	X	1
42	A257-9	Anti-seize	X	A/R
43	A701-3	Tape (0.5 in. wide polyethylene)	X	A/R
44	PPR-4850B	Push Rivet	X	2
45	A701-5	Tape (2 in. wide polyethylene)	X	A/R

NOTES

Intentionally Blank

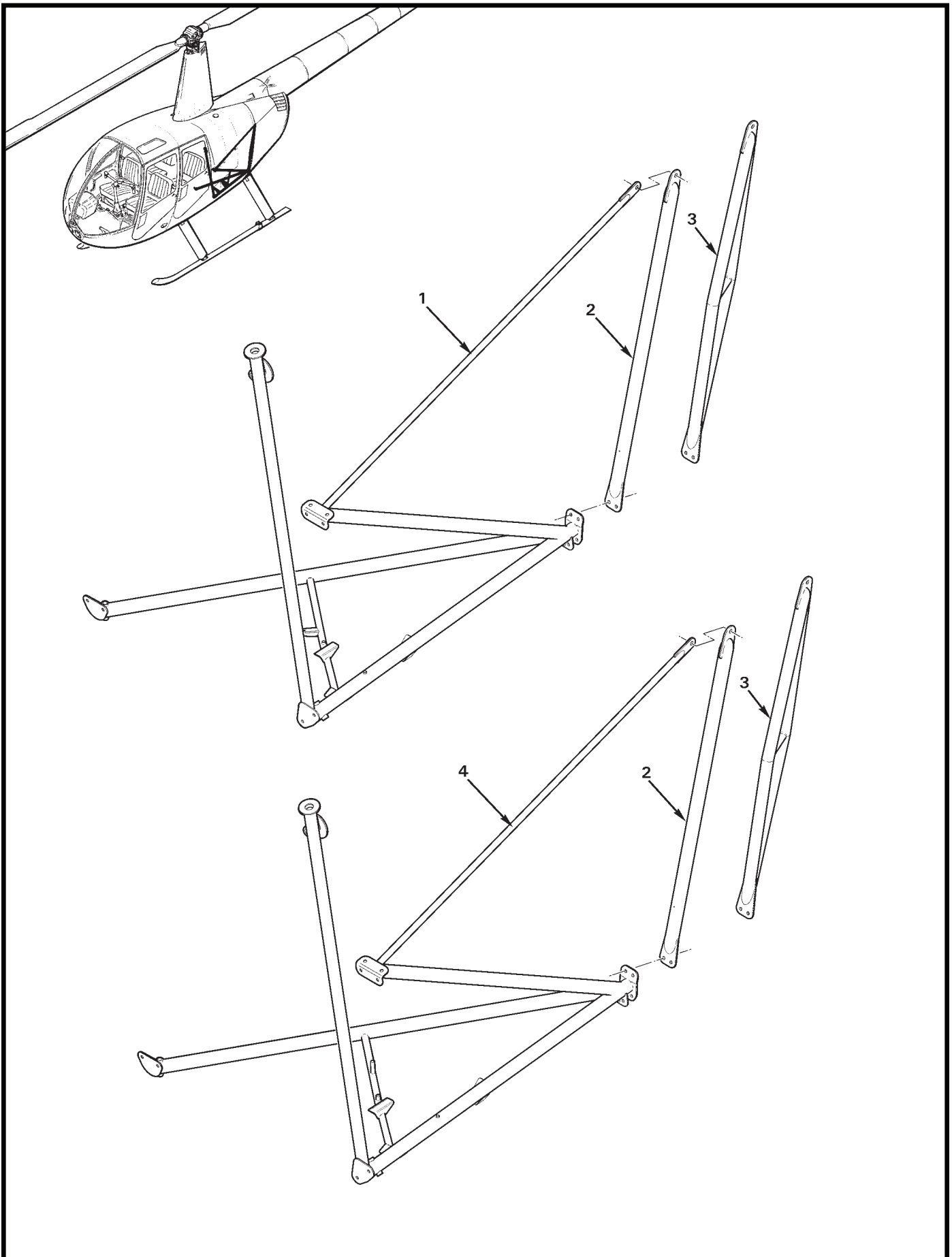

FIGURE AND INDEX NUMBER	PART NUMBER	DESCRIPTION	PARTS AVAIL	QTY PER ASSY
FRAME ASSEMBLIES				
53-23-1	C046-21	Lower Frame Assembly – LH (14V R44s, and Earlier non-A/C R44 IIs. Supersedes item 4. Has provision for 7.80 in. length battery box.)	X	1
	2 D046-2	Strut Weldment (LH, ship S/N 0001 thru 9999)	X	1
	3 D046-1	Strut Weldment (LH, ship S/N 10001 and subsequent)	X	1
	4 C046-19	Lower Frame Assembly – LH (No longer available; has provisions for 10.05-in. length battery box. Earlier R44 IIs require C046-23 [see Figure 53-19] frame assembly if A/C is installed.)	O	1

NOTES

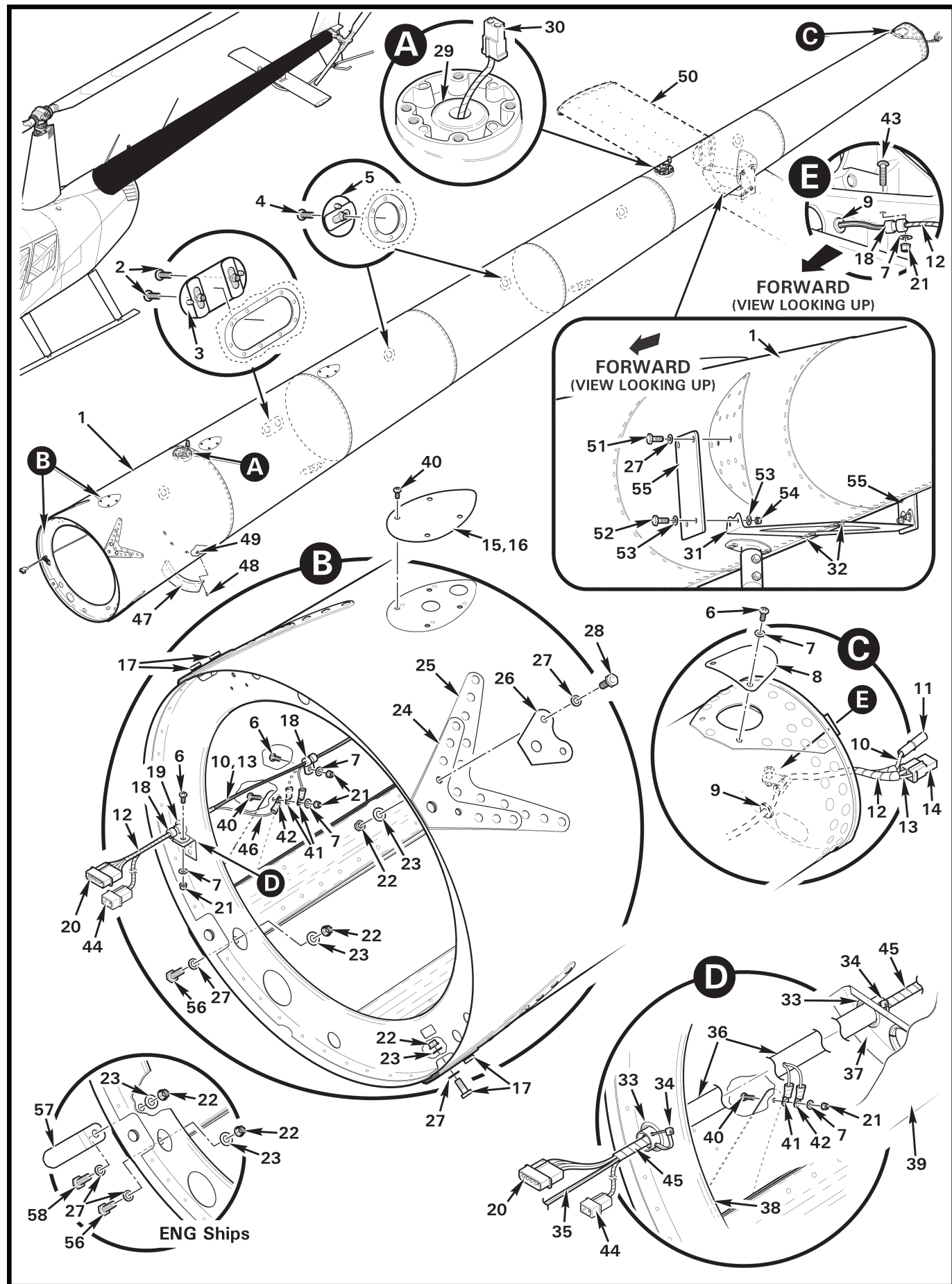

FIGURE AND INDEX NUMBER	PART NUMBER	DESCRIPTION	PARTS AVAIL	QTY PER ASSY
		TAILCONE ASSEMBLY (LED STROBE)		
53-25-1	C023-1	Tailcone Assembly (Provision for two antennas as shown. Includes items 3, 5 thru 14, 17 thru 32, 43, and 44. Also order items 51, 52, or 53 as required.)	X	1
	C023-4	Tailcone Assembly (For ENG helicopter. Provision for four antennas. Includes Battery box installation. See also Figures 96-29 and 96-31. Includes items 3, 5 thru 8, 10 thru 17, 19 thru 36, 43, 44, and 46; not shown. Also order items 51, 52, or 53 as required.)	X	1
	C023-14	Tailcone Assembly (Provision for four antennas plus NAV antennas. Includes items 3, 5 thru 14, and 17 thru 32; not shown. Also order items 51, 52, or 53 as required.)	X	1
	C023-15	Tailcone Assembly (Provision for two antennas plus NAV antennas. Includes items 3, 5 thru 14, and 17 thru 32; not shown. Also order items 51, 52, or 53 as required.)	X	1
2	MS27039C0807	Screw	X	2
3	A231-10	Plug Assembly (Incl item 2 [2])	X	1
4	MS27039C0807	Screw	X	5
5	A231-1	Plug Assembly (Incl item 4 [1])	X	5
6	MS27039C0806	Screw	X	2
7	NAS1149FN816P	Washer	X	7
8	A558-2	Cover – Tailcone	X	1
9	MS35489-33	Grommet	X	1
10	-109	Wire (Ref, tail light power)		
11	B263-11	Housing (wires to tail light)	X	1
	B263-2	Socket	X	1
12	B161-2	Spirap	X	A/R
13	-5	Wire (Ref, TRGB chip detector warning light)		
	-503	Wire (Ref, TRGB chip detector warning light test switch)		
14	B263-13	Housing (wires to tail rotor gearbox chip detector)	X	1
	B263-2	Socket	X	2
15	B322-2	Cover (install using item 16 when antenna is not installed) . . .	X	A/R
16	B270-13	Sealant	X	A/R
17	NAS6604-4	Bolt	X	4
18	MS21919WDG2	Clamp	X	3
19	B401-4	Grommet	X	1
20	B263-16	Housing	X	1
	B263-1	Pin	X	4

NOTES

Continues

FIGURE AND INDEX NUMBER	PART NUMBER	DESCRIPTION	PARTS AVAIL	QTY PER ASSY
TAILCONE ASSEMBLY (LED STROBE; Cont'd)				
53-25-21	MS21042L08	Nut	X	A/R
22	D210-4	Nut	X	14
23	A141-11	Washer	X	14
24	D078-2	Doubler (Ref)		
25	D078-3	Doubler (Ref)		
26	D078-1	Doubler	X	4
27	NAS1149F0432P	Washer	X	18
28	NAS6604-3	Bolt	X	2
29	MS35489-15	Grommet	X	1
30	B263-13	Housing	X	1
	B263-2	Socket	X	2
31	F955-1*	Bracket (Revision AW and subsequent, AV and prior with item 62 installed)	X	1
32	MS20470AD5	Rivet	X	6
33	NAS557-10A	Grommet (for tailcone camera installation only)	X	8
34	MS3367-5-9	Ty-Rap	X	2
35	C023-757	Cable (Ref)		
	C023-2815	Wire (Ref)		
36	D686-1	Conduit	X	1
37	D080-1	Bulkhead Assembly (Ref)		
38	D070-1	Bulkhead Assembly (Ref)		
39	C023-12	Skin (Ref)		
40	MS27039C0807	Screw	X	8
41	B260-3	Terminal (Ref, see Figure 33-1)		
42	B260-9	Terminal (Ref, see Figure 33-1)		
43	MS27039C0808	Screw	X	1
44	B263-12	Housing	X	1
	B263-3	Pin (-2388 power; additional -2854 ground wire, optional fwd strobe)	X	A/R
45	B161-4	Spirap (E.N.G. ships)	X	A/R
46	-2854	Wire	X	1
47	D300-1	Support (Ref, see Figure 53-5)		
	D300-2	Support (Ref, see Figure 53-5)		
48	MS27039C0806	Screw (Ref, see Figure 53-5)		
49	MS21069L08	Nutplate (Ref, see Figure 53-5)		

NOTES * Item 1 with F955-1 bracket may not be installed on R44 I helicopters if C169-1 exhaust muffler assembly (smaller, 6-in. dia. shroud assembly) is installed. (C169-35 exhaust muffler assembly, or C169-36 muffler sub-assembly may be installed per Figure 71-21).

Continues

FIGURE AND INDEX NUMBER	PART NUMBER	DESCRIPTION	PARTS AVAIL	QTY PER ASSY
TAILCONE ASSEMBLY (LED STROBE; Cont'd)				
53-25-50	F050-2	Horizontal Stabilizer Assembly (Ref, see Figure 53-45)		
51	NAS6604-3	Bolt	X	4
52	NAS6603-2	Bolt	X	4
53	NAS1149F0332P	Washer	X	8
54	D210-3	Nut	X	4
55	MT023-2	Support – Stabilizer Bracket (install when stabilizer is removed, using existing hardware)	X	2
56	NAS6604-5	Bolt	X	2
57	D399-3	Tab (install using item 58, for ENG helicopter)	X	1
58	NAS6604-6	Bolt	X	1
* * *				
59	KI-204-1 & -2	R44-series KI-204-1 [14-volt], KI-204-2 [28-volt] R44-series Airframe Provisions for Single LED-Strobe Tailcone Kit Instructions (Kit removes A708 strobe power supply and provides wiring for current production LED strobe-equipped-only tailcones. R44-series helicopters may also require secondary ground wire; see KI-251 for affected serial numbers.)	X	A/R
60	KI-276	R44-series and R66 B264-XX Connector Upgrade Kit Instructions (Replaces obsoleted B264-XX connectors with B263-XX connectors on C049-1 tail rotor gearbox chip detector harness assembly. C023 tailcone aft wire harness, and tail light wire on C044 horizontal stabilizer harness.)	X	A/R
61	KI-277-1	C023 Tailcone with GMU 44 Magnetometer Installation Kit Instructions (Transfers existing GMU 44 Magnetometer and F951-2 harness assembly optionally installed on R44 S/N 1068 & prior, R44 II S/N 14473 & prior, and Cadet S/N 30077 & prior, to C023 tailcone revision AV. See Figure 97-9.)	X	A/R
62	KI-285-2	R44-series Horizontal Stabilizer Retrofit Kit Instructions (Replaces C044-1 horizontal stabilizer with F044-1 vertical stabilizers mount assembly, and installs F050-2 horizontal symmetrical stabilizer assembly. Kit is not approved for R44 I helicopters fitted with C169-1 exhaust muffler assembly which has a shroud diameter of 6.0 inches.)	X	A/R

NOTES

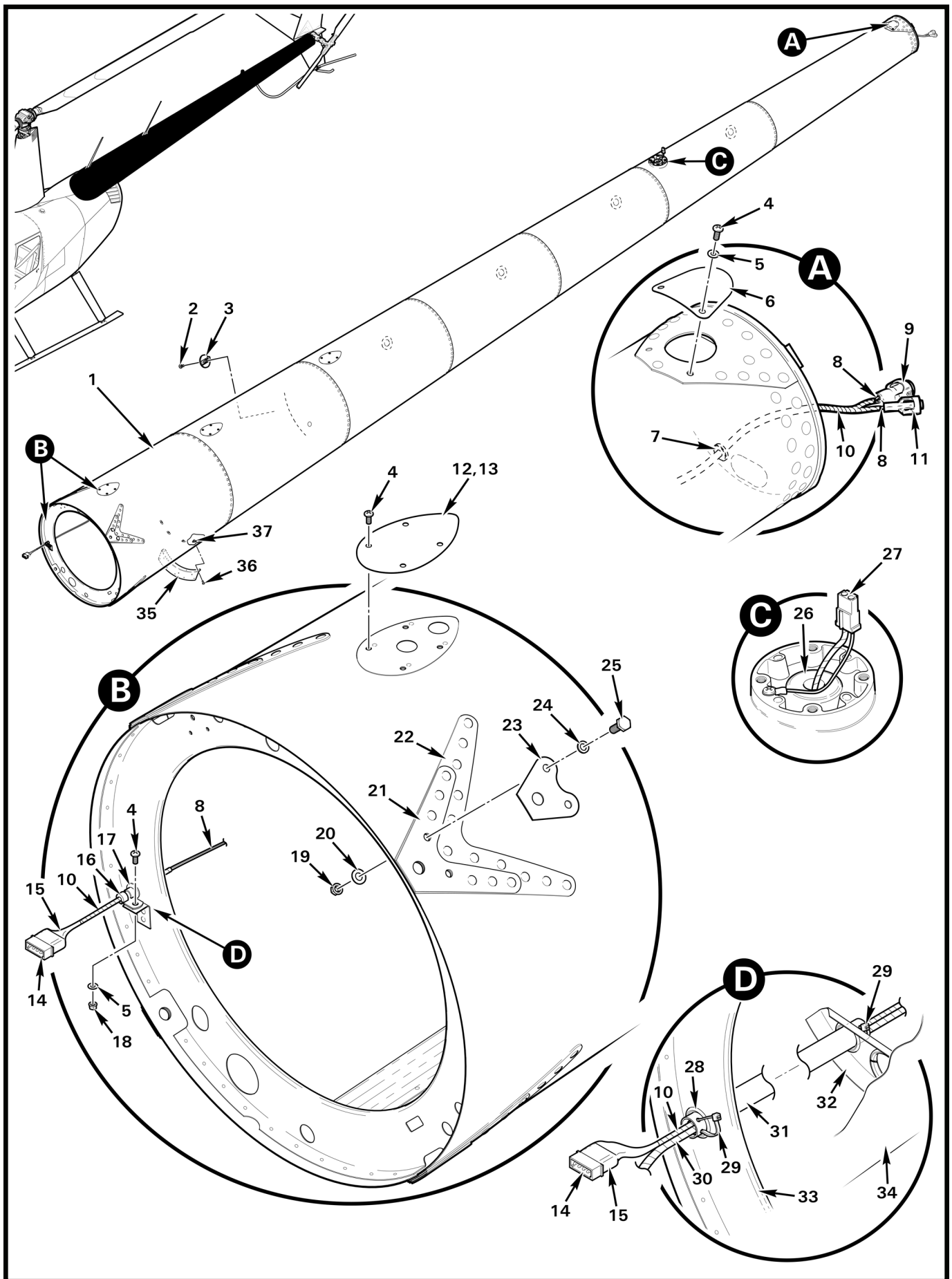

FIGURE AND INDEX NUMBER	PART NUMBER	DESCRIPTION	PARTS AVAIL	QTY PER ASSY
		TAILCONE ASSEMBLY (LED STROBE)*		
53-29-1	C023-1	Tailcone Assembly (Provision for two antennas as shown. Includes items 3 thru 11, and 14 thru 27.)	X	1
	C023-4	Tailcone Assembly (For ENG helicopter. Provision for four antennas. Includes tailcone battery box installation**. Includes items 3 thru 11, 14, 15, 19 thru 27, and 32 thru 35; not shown.)	X	1
	C023-14	Tailcone Assembly (Provision for four antennas plus NAV antennas. Includes items 3 thru 11, and 14 thru 27; not shown.)	X	1
	C023-15	Tailcone Assembly (Provision for two antennas plus NAV antennas. Includes items 3 thru 11, and 14 thru 27; not shown.)	X	1
2	MS27039C0807	Screw	X	1
3	A231-1	Plug Assembly (Incl item 2)	X	5
4	MS27039C0806	Screw	X	7
5	NAS1149FN816P	Washer	X	3
6	A558-2	Cover – Inspection (transparent)	X	1
7	MS35489-33	Grommet	X	1
8	B274-22	Wire (no. 5, 109, and 503)	X	A/R
9	B264-13	Plug (to tail rotor gearbox chip detector)	X	1
	B263-2	Socket	X	2
10	B161-2	Spirap	X	A/R
11	B264-11	Plug (to tail light)	X	1
	B264-4	Socket	X	1
12	B322-2	Cover (for use when antenna not installed; install using item 13)	X	1
13	B270-1	Sealant	X	A/R
14	B263-16	Housing (to tail light and tail rotor gearbox chip detector)	X	1
	B263-1	Pin	X	4
15	B158-8	Heat Shrink (around housing and wires)	X	A/R
16	MS21919WDG2	Clamp	X	1
17	B401-4	Grommet	X	1
18	MS21042L08	Nut	X	8
19	MS21042L4	Nut	X	8
20	A141-11	Washer	X	8
21	D078-2	Doubler (Ref)		
22	D078-3	Doubler (Ref)		

NOTES * If not previously accomplished, earlier ships require KI-204 Airframe Provisions for Single LED-Strobe Tailcone Kit Installation if an LED-equipped tailcone is to be installed.

** See also Figures 96-29 and 96-31.

Continues

FIGURE AND INDEX NUMBER	PART NUMBER	DESCRIPTION	PARTS AVAIL	QTY PER ASSY
TAILCONE ASSEMBLY (LED STROBE) (Cont'd)				
53-29-23	D078-1	Doubler	X	4
24	NAS1149F0432P	Washer	X	8
25	NAS6604-4	Bolt	X	8
26	MS35489-15	Grommet (standard)	X	1
	MS35489-11	Grommet (forward strobe location option; not shown)	X	1
27	B263-13	Housing	X	1
	B263-2	Socket	X	2
28	NAS557-10A	Grommet (for ENG ships only)	X	8
29	MS3367-5-9	Ty-Rap	X	2
30	D572	Cable Assembly (Ref)		
31	D686-1	Conduit	X	1
32	D080-1	Bulkhead Assembly (Ref)		
33	D070-1	Bulkhead Assembly (Ref)		
34	C023-12	Skin (Ref)		
35	D300	Support (Ref, See Figure 53-5)		
36	MS27039C0806	Screw (Ref)		
37	MS21069L08	Nutplate (Ref)		

NOTES

Intentionally Blank

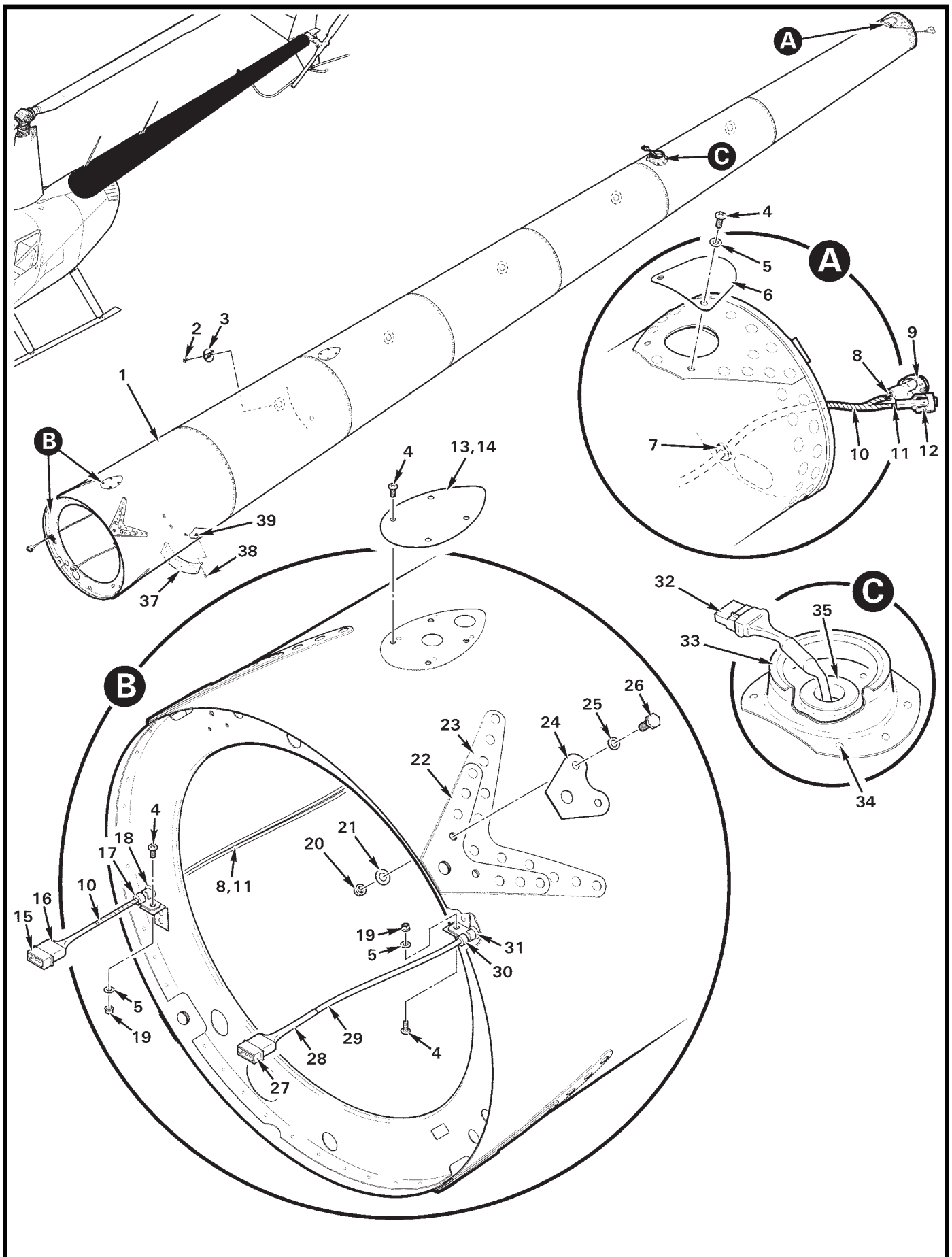

FIGURE AND INDEX NUMBER	PART NUMBER	DESCRIPTION	PARTS AVAIL	QTY PER ASSY	
TAILCONE ASSEMBLY					
53-33-1	C023-1	Tailcone Assembly (Provision for two antennas as shown. Includes items 3 thru 12, and 15 thru 34.)	X	1	
	C023-2	Tailcone Assembly (tailcone battery box, no longer available) . .	O	1	
	C023-3	Tailcone Assembly (For Police helicopter. Provision for four antennas. Includes tailcone battery box installation*. Includes items 3 thru 12, and 15 thru 34; not shown.)	X	1	
	C023-4	Tailcone Assembly (For ENG helicopter. Provision for four antennas. Includes tailcone battery box installation*. Includes items 3 thru 12, and 15 thru 34; not shown.)	X	1	
	C023-14	Tailcone Assembly (Provision for four antennas plus NAV antennas. Includes items 3 thru 12, and 15 thru 34; not shown.)	X	1	
	C023-15	Tailcone Assembly (Provision for two antennas plus NAV antennas. Includes items 3 thru 12, and 15 thru 34; not shown.)	X	1	
	2	MS27039C0807	Screw	X	1
	3	A231-1	Plug Assembly (Incl item 2)	X	5
	4	MS27039C0806	Screw	X	8
	5	NAS1149FN816P	Washer	X	4
	6	A558-2	Cover – Inspection (transparent)	X	1
	7	MS35489-33	Grommet (install using item 34)	X	1
		MS35489-35	Grommet (ENG ships; install using item 34)	X	1
	8	B274-22	Wire (no. 5 and 503)	X	A/R
	9	B264-13	Plug (to tail rotor gearbox chip detector)	X	1
		B263-2	Socket	X	2
	10	B161-2	Spirap	X	A/R
11	B274-16	Wire (no. 109)	X	A/R	
12	B264-11	Plug (to tail light)	X	1	
	B264-4	Socket	X	1	
13	B322-2	Cover (for use when antenna not installed; install using item 14)	X	1	
14	B270-4	Sealant	X	A/R	
15	B263-14	Housing (to tail light and tail rotor chip detector)	X	1	
	B263-1	Pin	X	2	
	B263-3	Pin	X	1	
16	B158-8	Heat Shrink (around housing and wires)	X	A/R	
17	MS21919WDG2	Clamp	X	1	

NOTES * See also Figure 96-29.

Continues

FIGURE AND INDEX NUMBER	PART NUMBER	DESCRIPTION	PARTS AVAIL	QTY PER ASSY
TAILCONE ASSEMBLY (Cont'd)				
53-33-18	MS35489-33	Grommet (install using item 36)	X	1
19	MS21042L08	Nut	X	A/R
20	MS21042L4	Nut	X	8
21	A141-11	Washer	X	8
22	D078-2	Doubler (Ref)	O	4
23	D078-3	Doubler (Ref)	O	4
24	D078-1	Doubler	X	4
25	NAS1149F0432P	Washer	X	8
26	NAS6604-4	Bolt	X	8
27	B263-14	Housing (to strobe light)	X	1
	B263-3	Pin	X	3
28	B158-6	Heat Shrink (around wires)	X	A/R
	B158-8	Heat Shrink (around housing and cable)	X	A/R
29	B274-450	Cable (wire no. 1454 [red], 1455 [black], 1456 [clear])	X	A/R
30	MS21919WDG4	Clamp	X	1
31	MS35489-35	Grommet	X	1
32	B263-15	Housing	X	1
	B263-4	Socket	X	3
33	C528-2	Mount (strobe light)	X	1
34	NAS9301B-4-02	Rivet	X	6
35	MS35489-18	Grommet	X	1
36	B270-8qt	Adhesive	X	A/R
37	D300	Support (Ref, see Figure 53-5)		
38	MS27039C0806	Screw (Ref)		
39	MS21069L08	Nutplate (Ref)		

NOTES

Intentionally Blank

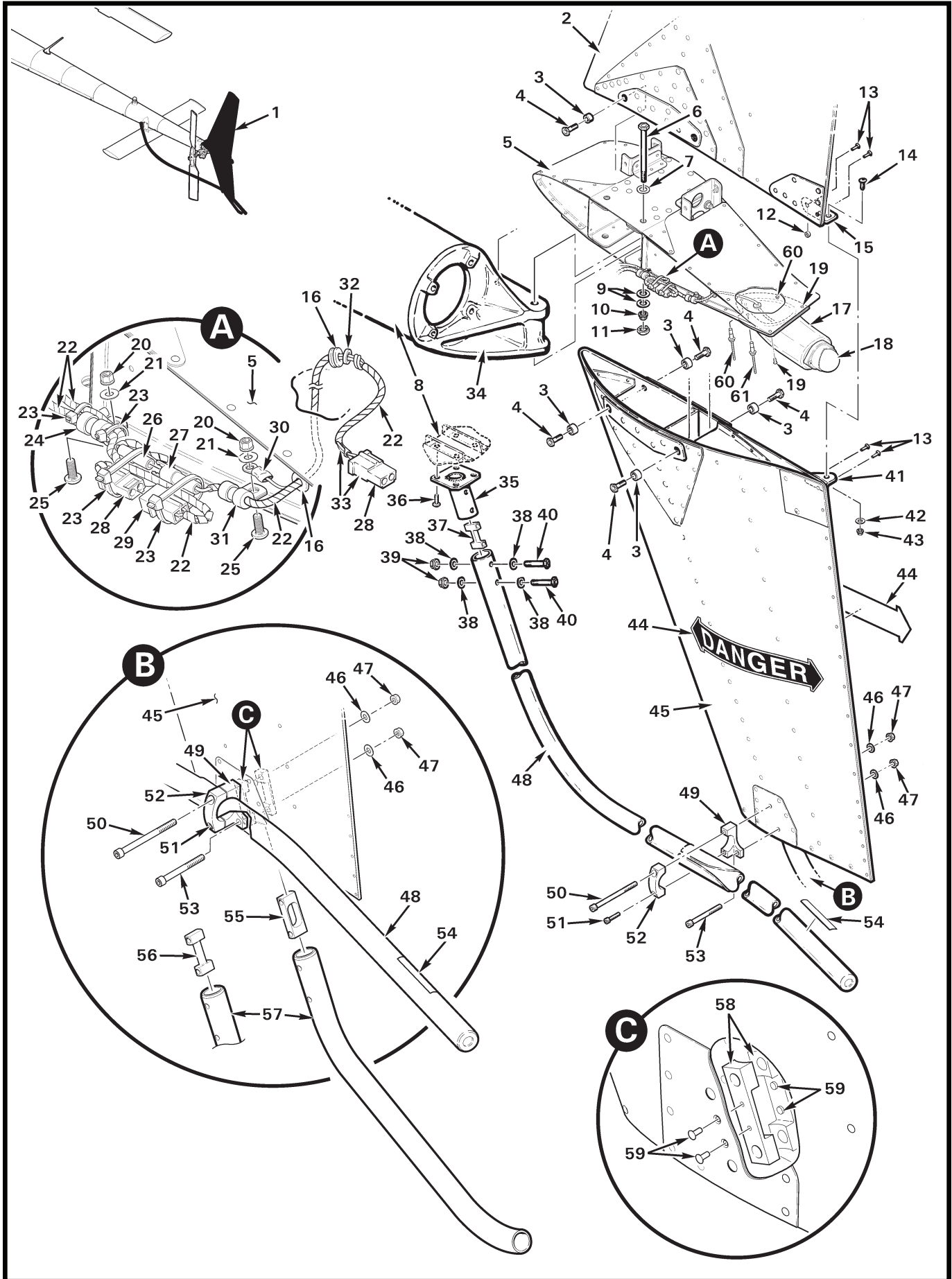

FIGURE AND INDEX NUMBER	PART NUMBER	DESCRIPTION	PARTS AVAIL	QTY PER ASSY
F004-2 EMPENNAGE ASSEMBLY				
53-37-1	F004-2*	Empennage Assembly (Incl items 2 thru 5, 12 thru 15, 41 thru 43, and 45)	X	1
2	C042-1	Stabilizer – Upper Vertical (does not include items 12, 13, and 15)	X	1
3	C130-9	Spacer	X	8
4	NAS6604-6	Bolt	X	8
5	F044-1*	Mount Assembly – Vertical Stabilizers (Incl items 17, 19, 33, 60, and 61)	X	1
6	NAS6606-47	Bolt	X	2
7	NAS1149F0632P	Washer	X	2
8	C023-1, -4, -14, & -15	Tailcone Assembly (Ref, see Figure 53-25)		
9	NAS1149F0663P	Washer ([1] or [2] under nut as required to meet torque requirements per R44 MM § 23-30 Part E.)	X	A/R
10	D210-6	Nut	X	2
11	B330-19	Palnut	X	2
12	A130-14	Spacer	X	1
13	MS20470AD4	Rivet	X	4
14	MS35206-228	Screw	X	1
15	C554-2	Clip – Upper (Vertical Stabilizer)	X	1
16	MS35489-4	Grommet	X	2
17	C529-1	Mount Assembly – Tail Light	X	1
18	01-0771554-01**	Light Assembly – Tail Light (Ref, see Figure 33-7)		
19	MS20470AD3	Rivet	X	2
20	MS21042L08	Nut	X	2
21	NAS1149FN816P	Washer	X	2
22	B161-2	Spirap	X	A/R
23	MS3367-5-0	Ty-Rap	X	A/R
24	MS21919WDG3	Clamp	X	1
25	MS27039C0806	Screw	X	2
26	B263-11	Housing	X	1
	B263-2	Socket	X	1
27	B263-10	Housing	X	1
	B263-1	Pin	X	1
28	B263-13	Housing	X	2
	B263-2	Socket	X	4

NOTES * May only be installed if F955-1 bracket is installed on tailcone, see Figure 53-25.
 ** Whelen part number.

Continues

FIGURE AND INDEX NUMBER	PART NUMBER	DESCRIPTION	PARTS AVAIL	QTY PER ASSY
F004-2 EMPENNAGE ASSEMBLY (Cont'd)				
53-37-29	B263-12	Housing	X	1
	B263-1	Pin	X	2
30	B260-3	Terminal	X	1
31	MS21919WDG2	Clamp	X	1
32	90295A075	Washer	X	1
33	D049-8	Wire Harness Assembly – Tail Light (includes items 16, 22, 27, 28 [1], 30, 32, and wires; assembled)	X	1
34	C148	Bulkhead Assembly (Ref)		
35	D082-1	Tube Assembly – Tail Rotor Guard Mount (lightly coat mating surface to item 48 with wet primer)		
36	MS27039C1-07	Screw	X	4
37	D081-1	Spacer (lightly coat mating surface to item 35 with wet primer prior to installation)	X	1
38	NAS1149F0332P	Washer	X	4
39	D210-3	Nut	X	2
40	NAS6603-16	Bolt (install using wet primer on shank)	X	2
41	C554-1	Clip – Lower (Vertical Stabilizer)	X	1
42	NAS1149FN616P	Washer	X	1
43	MS21042L06	Nut	X	1
44	C654-2	Decal – "DANGER"	X	2
45	C043-1	Stabilizer – Lower Vertical (includes items 58 and 59; does not include items 13, 41, 44, and 57)	X	1
46	NAS1149F0432P	Washer	X	2
47	D210-4	Nut	X	2
48	D079-1	Tail Rotor Guard Assembly (Includes item 54; does not include items 35 and 37. Lightly coat inside top of guard with wet primer prior to installing item 35. Seal around seam with primer after installation.)	X	1
49	D081-4	Block Assembly	X	1
50	NAS1351-4-51P	Screw	X	1
51	NAS1352-3-14P	Screw	X	1
52	D081-2	Block – Cap	X	1
53	NAS1351-4-36P	Screw	X	1
54	C654-18	Decal – "NO HAND HOLD"	X	1
55	C470-3	Spacer	X	1
56	C470-3	Spacer (Ref; revision I and prior no longer available)		
57	C470-1	Tail Skid	X	1

NOTES

Continues

FIGURE AND INDEX NUMBER	PART NUMBER	DESCRIPTION	PARTS AVAIL	QTY PER ASSY
F004-2 EMPENNAGE ASSEMBLY (Cont'd)				
53-37-58	C470-2	Block	X	2
59	MS20426AD3	Rivet	X	4
60	NAS9301B-4-01	Rivet (or NAS9301B-4-02)	X	2
61	NAS9301B-4-02	Rivet (or NAS9301B-4-03)	X	1
NOTES				

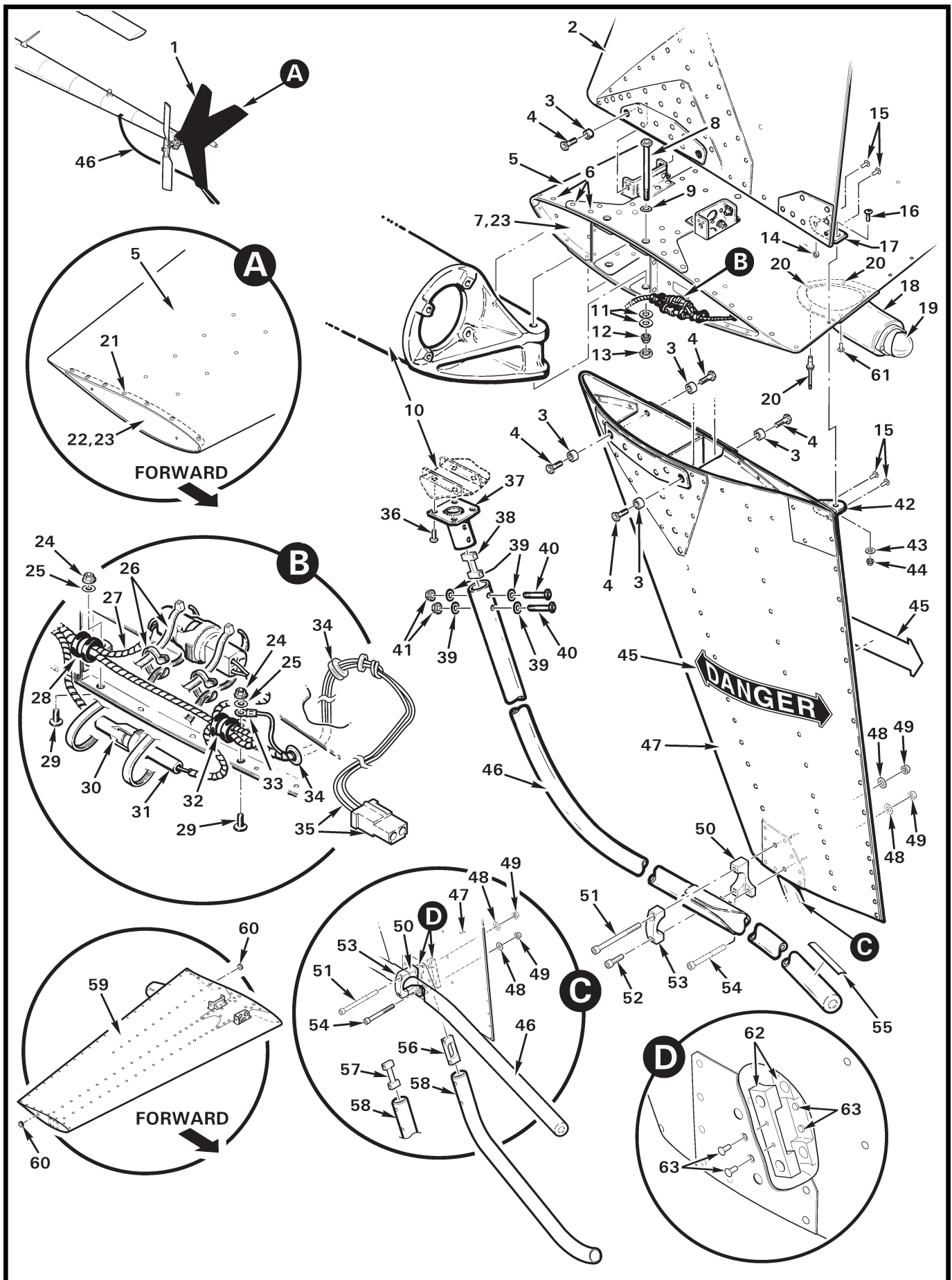

FIGURE AND INDEX NUMBER	PART NUMBER	DESCRIPTION	PARTS AVAIL	QTY PER ASSY
		C004-2 EMPENNAGE ASSEMBLY		
53-41-1	C004-2*	Empennage Assembly (Includes items 2 thru 5, 14 thru 17, 23, 42 thru 44, and 47, does not include item 45. Also order item 64 as required.)	X	1
2	C042-1	Stabilizer – Upper Vertical (does not include items 14, 15, and 17)	X	1
3	C130-9	Spacer	X	8
4	NAS6604-6	Bolt	X	8
5	C044-1*	Stabilizer – Horizontal (Incl items 6, 7, 18, 20 thru 23, and 35)	X	1
6	MS20470AD3	Rivet	X	10
7	D292-2	Rib (inboard; seal around joint using item 23)	X	1
8	NAS6606-47	Bolt	X	2
9	NAS1149F0632P	Washer	X	2
10	C023	Tailcone Assembly (Ref)		
11	NAS1149F0663P	Washer ([1] or [2] under nut to meet torque requirements per R44 MM § 23-30 part E.)	X	A/R
12	D210-6	Nut	X	2
13	B330-19	Palnut	X	2
14	A130-14	Spacer	X	1
15	MS20470AD4	Rivet	X	4
16	MS35206-228	Screw	X	1
17	C554-2	Clip – Upper Vertical Stabilizer	X	1
18	C529-1	Mount Assembly – Tail Light	X	1
19	01-0771554-01**	Light Assembly – Tail Light (Ref, see Figure 33-7)		
20	NAS9301B-4-02	Rivet (or NAS1919B04S02)	X	3
21	NAS9301B-4-01	Rivet (or NAS1919B04S01)	X	14
22	D292-3	Rib (outboard; seal around joint using item 23)	X	1
23	B270-1	Sealant	X	1
24	MS21042L08	Nut	X	2
25	NAS1149FN816P	Washer	X	2
26	MS3367-5-9	Ty-Rap	X	4
27	B161-2	Spirap	X	A/R
28	MS21919WDG3	Clamp	X	1
29	MS27039C0806	Screw	X	2
30	B264-11	Housing	X	1
	B264-2	Socket	X	1

NOTES * May not be installed if F955-1 bracket is installed on tailcone, see Figure 53-25.
 ** Whelen part number.

Continues

FIGURE AND INDEX NUMBER	PART NUMBER	DESCRIPTION	PARTS AVAIL	QTY PER ASSY
C004-2 EMPENNAGE ASSEMBLY (Cont'd)				
53-41-31	B264-10	Housing	X	1
	B264-1	Pin	X	1
32	MS21919WDG2	Clamp	X	1
33	B260-3	Terminal	X	1
34	MS35489-4	Grommet	X	2
35	D049-3	Wire Harness Assembly – Tail Light (Includes items 27, 30, 34, B264-1 pin, [2] B264-2 sockets, B264-13 housing, 90295A075 plastic washer, and wires; assembled. Replaced by D049-8, see Figure 53-37.)	X	1
36	MS27039C1-07	Screw	X	4
37	D082-1	Tube Assembly – Tail Rotor Guard Mount (lightly coat mating surface to item 46 with wet primer)	X	1
38	D081-1	Spacer (lightly coat with wet primer prior to installation)	X	2
39	NAS1149F0332P	Washer	X	4
40	NAS6603-16	Bolt (install using wet primer)	X	2
41	D210-3	Nut	X	2
42	C554-1	Clip – Lower Vertical Stabilizer	X	1
43	NAS1149FN616P	Washer	X	1
44	MS21042L06	Nut	X	1
45	C654-2	Decal – “Danger”	X	2
46	D079-1	Tail Rotor Guard (Includes item 55. Lightly coat inside top of guard with primer before installing item 37. Seal around seam with primer after installation.)	X	1
47	C043-1	Stabilizer – Lower Vertical (includes items 23, 62, and 63; does not include items 42, 45, and 58)	X	1
48	NAS1149F0432P	Washer	X	2
49	D210-4	Nut	X	2
50	D081-4	Block Assembly	X	1
51	NAS1351-4-51P	Screw	X	1
52	NAS1352-3-14P	Screw	X	1
53	D081-2	Block – Cap	X	1
54	NAS1351-4-36P	Screw	X	1
55	C654-18	Decal – “No Hand Hold”	X	1
56	C470-3	Spacer	X	1
57	C470-3	Spacer (Ref, revision I and prior no longer available)		
58	C470-1	Tail Skid	X	1
59	D097-11*	Stabilizer – Horizontal (Incl items 5 and 60)	X	1

NOTES * ENG ships only.

Continues

FIGURE AND INDEX NUMBER	PART NUMBER	DESCRIPTION	PARTS AVAIL	QTY PER ASSY
C004-2 EMPENNAGE ASSEMBLY (Cont'd)				
53-41-60	MS35489-9*	Grommet	X	2
61	MS20426AD3	Rivet	X	2
62	C470-2	Block	X	2
63	MS20470AD4	Rivet	X	4
* * *				
64	KI-276	R44-series and R66 B264-XX Connector Upgrade Kit Instructions (Replaces obsoleted B264-XX connectors with B263-XX connectors on C049-1 tail rotor gearbox chip detector harness assembly. C023 tailcone aft wire harness, and tail light wire on C044 horizontal stabilizer harness.)	X	A/R

NOTES * ENG ships only.

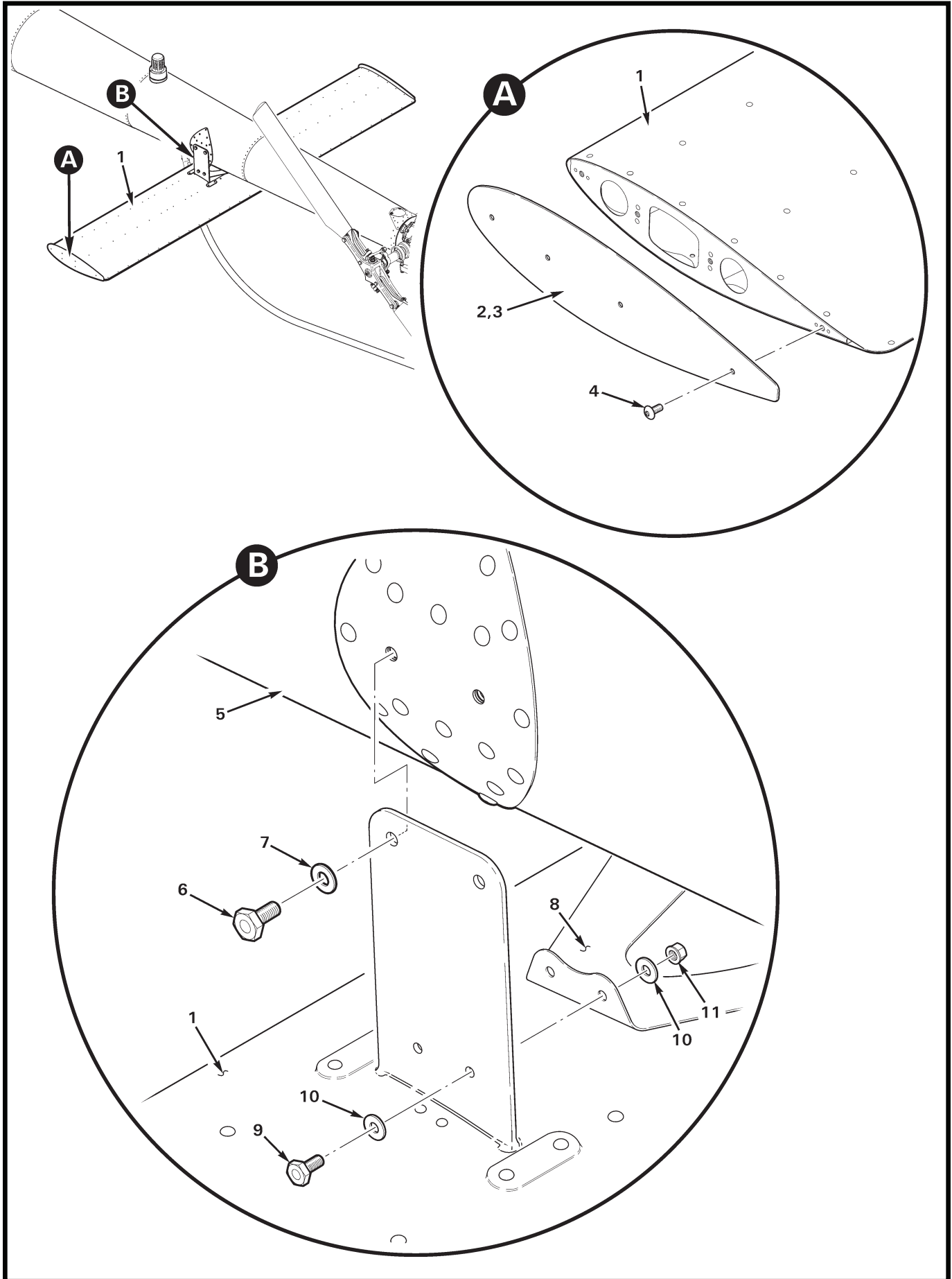

FIGURE AND INDEX NUMBER	PART NUMBER	DESCRIPTION	PARTS AVAIL	QTY PER ASSY
F050-2 HORIZONTAL STABILIZER INSTALLATION				
53-45-1	F050-2	Horizontal Stabilizer Assembly (Incl items 2 thru 4)	X	1
2	F952-3	Plate (seal all around plate in joint, where plate attaches to stabilizer using item 3)	X	2
3	B270-1	Sealant	X	A/R
4	B526-66	Screw (do not substitute)	X	8
5	C023-1, -2, -4, -14, & -15*	Tailcone Assembly (Ref)		
6	NAS6604-3*	Bolt (Ref)		
7	NAS1149F0432P*	Washer (Ref)		
8	F955-1*	Bracket (Ref)		
9	NAS6603-2*	Bolt (Ref)		
10	NAS1149F0332P*	Washer (Ref)		
11	D210-3*	Nut (Ref)		
12	A651-1	Data Plate (not shown)	O	1

NOTES * See Figure 53-25.

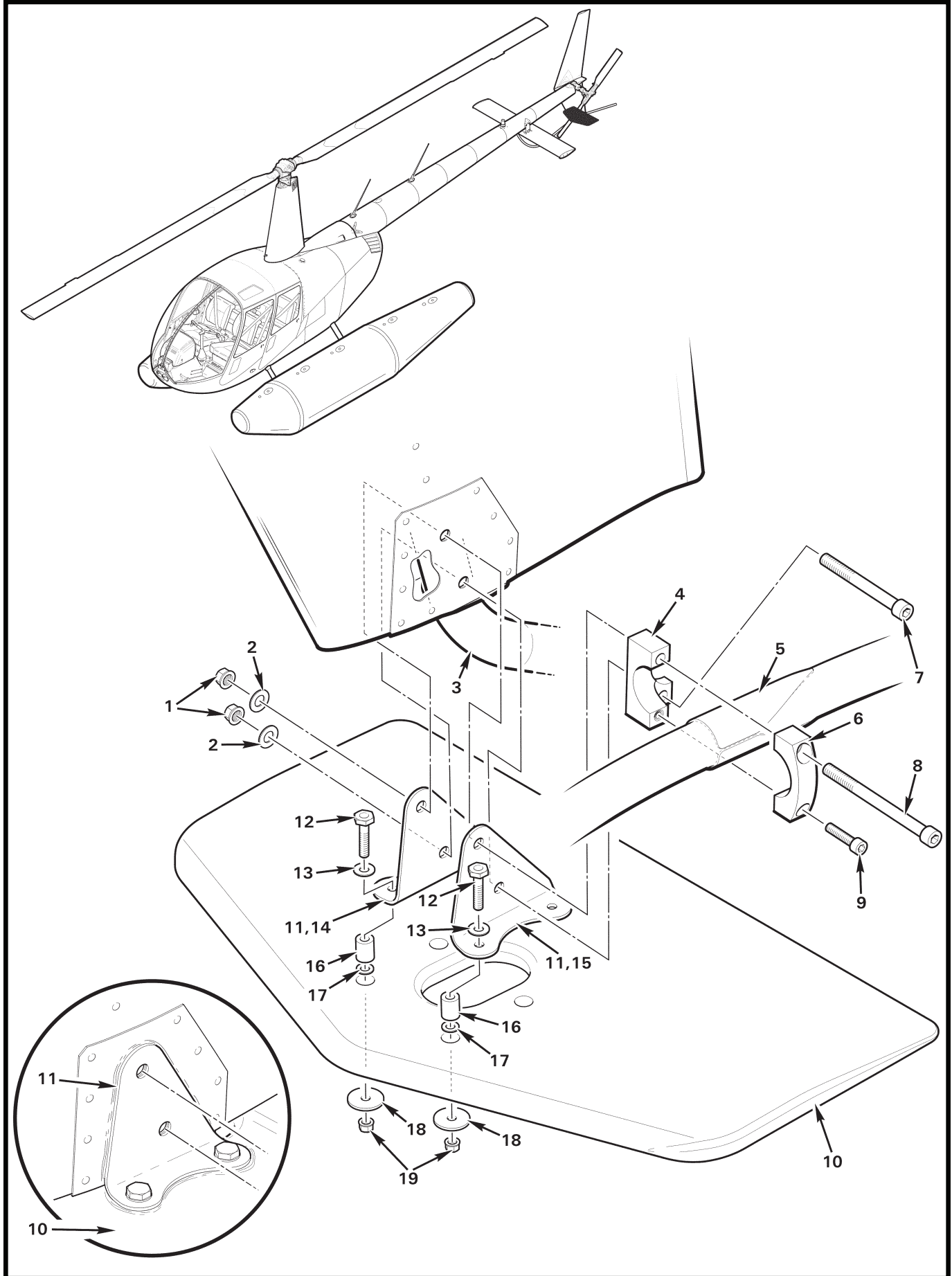

FIGURE AND INDEX NUMBER	PART NUMBER	DESCRIPTION	PARTS AVAIL	QTY PER ASSY
C050-2 FLOAT STABILIZER INSTALLATION				
53-47-1	D210-4	Nut	X	2
2	NAS1149F0432P	Washer	X	2
3	C470-1	Tail Skid (Ref, see Figure 53-37)		
4	D081-4	Block Assembly	X	1
5	D079-1	Tail Rotor Guard (Ref, see Figure 53-37)		
6	D081-2	Block – Cap	X	1
7	NAS1351-4-38P	Screw	X	1
8	NAS1351-4-53P	Screw	X	1
9	NAS1352-3-14P	Screw	X	1
10	C050-2	Stabilizer Assembly (Incl items 11 thru 16, 18, and 19)	X	1
11	B270-1	Sealant (2-oz tube)	X	A/R
12	NAS6603-9	Bolt (one exposed thread minimum permissible)	X	4
13	NAS1149F0332P	Washer	X	4
14	C971-4	Bracket (RH, seal around edges using item 11)	X	1
15	C971-3	Bracket (LH, seal around edges using item 11)	X	1
16	A130-35	Spacer	X	4
17	NAS620-10L *	Washer	X	A/R
18	A141-18	Washer (seal around edges using item 11)	X	4
19	MS21042L3	Nut	X	4

NOTES * Install one under item 18, (4) places if stabilizer is more than 0.015-inch thicker than spacer length.

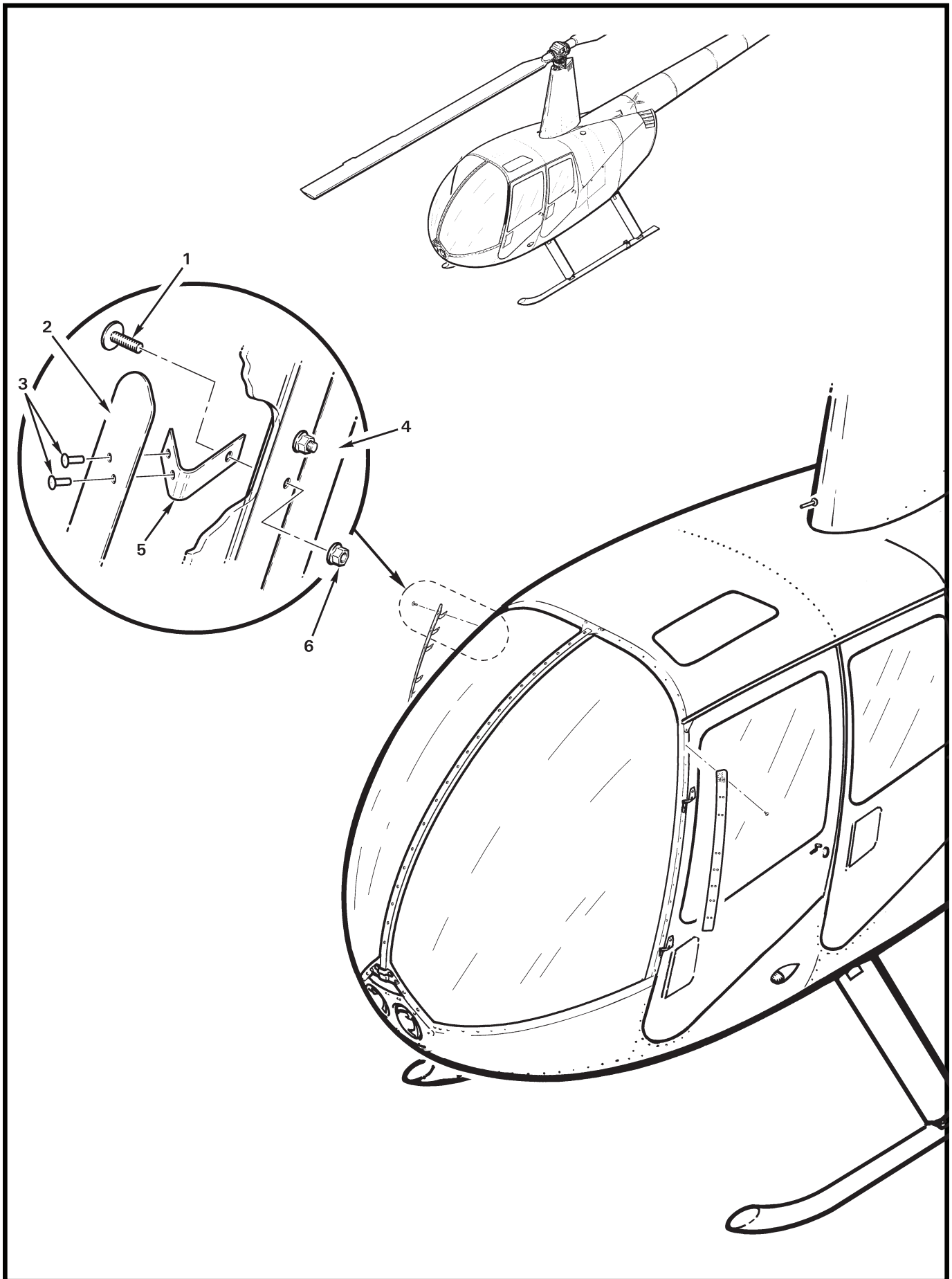

FIGURE AND INDEX NUMBER	PART NUMBER	DESCRIPTION	PARTS AVAIL	QTY PER ASSY
WIND DEFLECTOR INSTALLATION				
53-49-1	AN526C832R8	Screw	X	16
2	B228-1	Deflector (LH or RH)	X	2
3	MS20470AD4	Rivet	X	32
4	—	Door Jamb (Ref)		
5	B228-2	Angle	X	16
6	MS21042L08	Nut	X	16
NOTES				

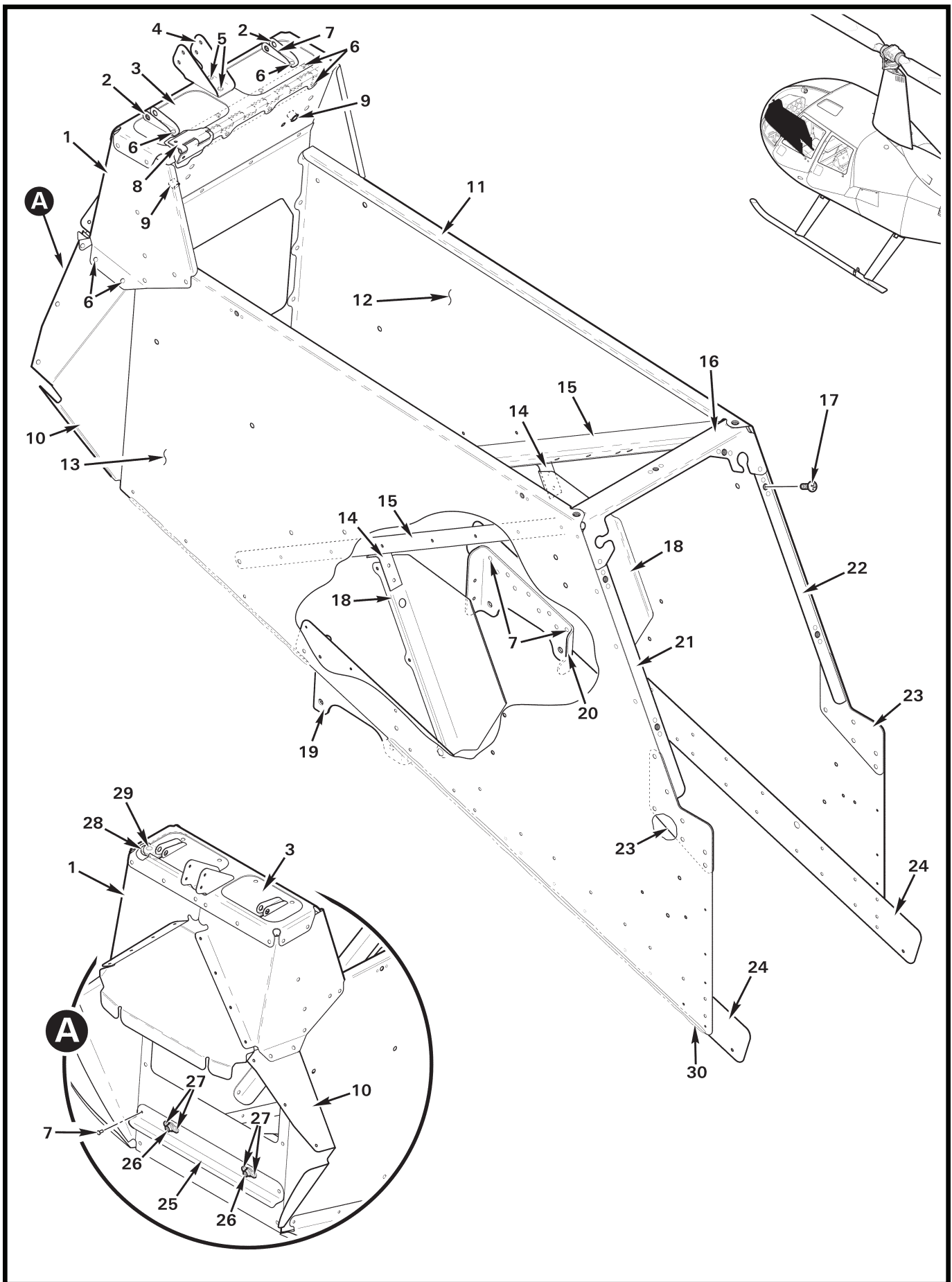

FIGURE AND INDEX NUMBER	PART NUMBER	DESCRIPTION	PARTS AVAIL	QTY PER ASSY
LOWER CONSOLE ASSEMBLY				
53-51-1	C062-1	Vent Box Assembly (Incl items 2, 3, and 6 thru 9)	X	1
2	A523-4	Channel	X	2
3	C358-4	Flap	X	1
4	C358-2	Support	X	1
5	MS20426AD4	Rivet	X	3
6	MS20470AD3	Rivet	X	A/R
7	MS20470AD4	Rivet	X	A/R
8	A523-3	Hinge	X	1
9	A130-36	Spacer (install using MS20470AD5 rivet)	X	2
10	C361-1	Panel	X	1
11	C033-1	Lower Console Assembly (Incl items 1, 4, 5, 10, and 12 thru 25)	X	1
12	C359-2	Panel (RH)	X	1
13	C359-1	Panel (LH)	X	1
14	A737-1	Clip	X	2
15	C365-1	Angle	X	2
16	C368-1	Support Assembly (includes MS21069L08 nutplates)	X	1
17	MS27039C0806	Screw	X	5
18	A371-3	Stiffener	X	2
19	A359-1	Support (LH)	X	1
20	A359-2	Support (RH)	X	1
21	C365-5	Angle Assembly (LH, includes MS21075L08E nutplates)	X	1
22	C365-6	Angle Assembly (RH, includes MS21075L08E nutplates)	X	1
23	C365-3	Doubler	X	2
24	C365-4	Doubler	X	2
25	C360-4	Stiffener Assembly (Includes items 26 and 27. Install using item 7 [2].)	X	1
26	MS21069L3	Nutplate	X	2
27	NAS1097AD3	Rivet	X	4
28	C358-7	Weight (install using item 29)	X	1
29	MS20426AD4	Rivet	X	1
30	B270-1	Sealant (for use on Clipper)	X	A/R

NOTES

Intentionally Blank

CHAPTER 62

MAIN ROTOR

<i>Figure</i>	<i>Title</i>	<i>Page</i>
62-1	Main Rotor Blade Assembly	62.0
62-3	Main Rotor Blade Assembly	62.2
62-7	Main Rotor Hub Installation	62.6

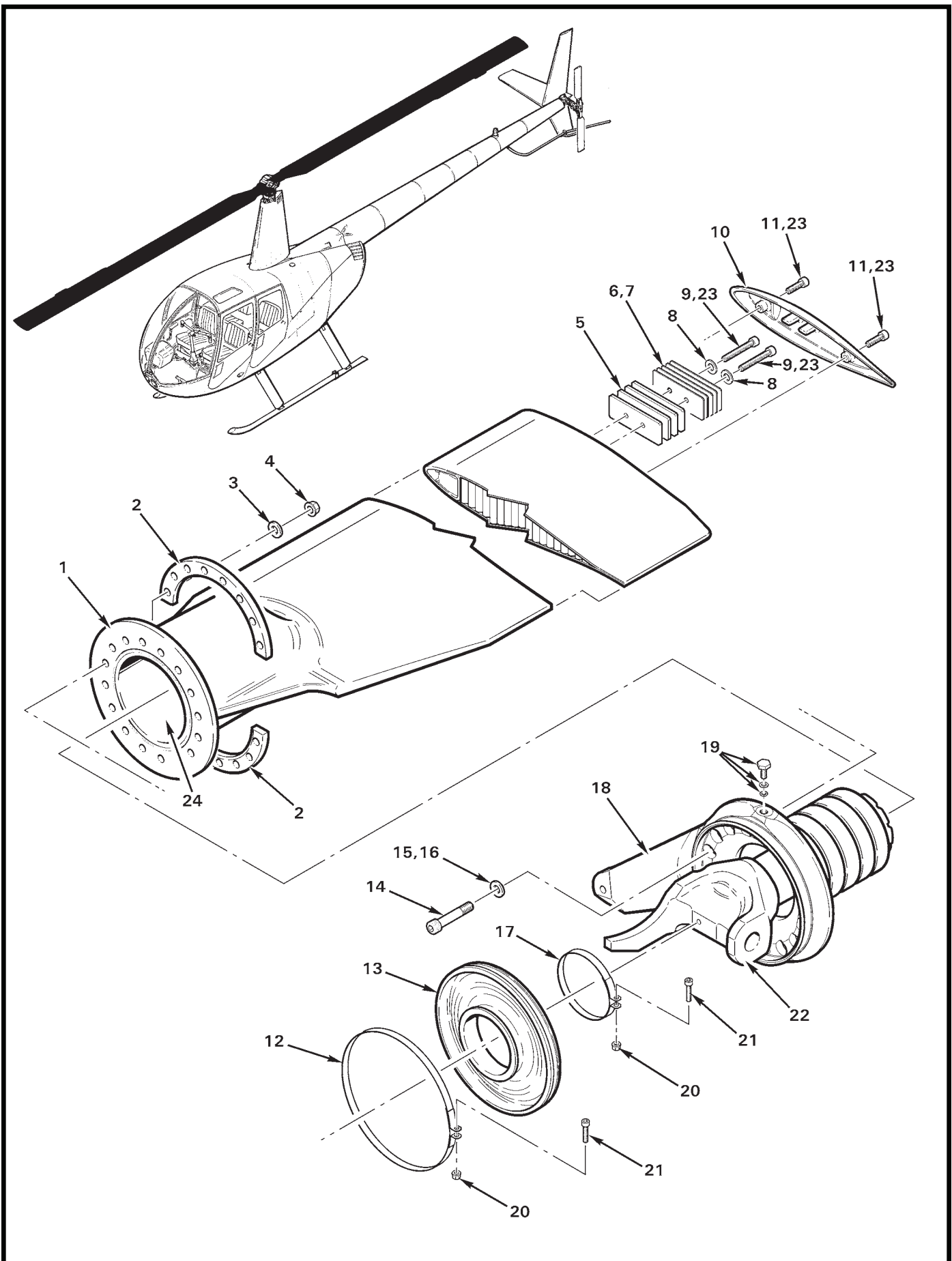

FIGURE AND INDEX NUMBER	PART NUMBER	DESCRIPTION	PARTS AVAIL	QTY PER ASSY
		MAIN ROTOR BLADE ASSEMBLY*		
62-1-1	C005-12**	Main Rotor Blade and Spindle Assembly – Extended Tab (Incl items 2 thru 4, 14 thru 16, 18, 19, and 24)	X	2
	C005-12R	Main Rotor Blade and Spindle Assembly (Two blade set, overhaul exchange; R9593 core deposit req'd. Includes R5352 shipping crate.)	X	1
	C016-7***	Blade Assembly – Extended Tab	O	1
2	C253-2	Spacer (eight holes)	O	2
3	NAS1149F0563P	Washer	X	16
4	D210-5	Nut	X	16
5	C298-4	Balance Strip (0.125 in. thick steel)	X	A/R
6	C298-3	Balance Strip (0.032 in. thick steel)	X	A/R
7	C298-2	Balance Strip (0.040 in. thick aluminum)	X	A/R
8	NAS1149F0332P	Washer (or NAS1149F0363P A/R for balance)	X	A/R
9	C722-3	Screw (install using item 23)	X	2
10	C300-3	Tip Cover (round)	X	1
11	NAS1351N3-12	Screw	X	2
12	C165-2	Clamp (Incl items 20 and 21)	X	1
13	C156-1	Boot (standard, black)	X	1
	C156-2	Boot (optional for sub-freezing operations, gray)	X	1
14	C722-1	Screw (install using item 23)	O	16
15	NAS1149F0563P	Washer (install using item 16, both sides)	X	16
16	B270-1	Sealant (2-oz tube)	X	A/R
17	C165-1	Clamp (Incl items 20 and 21)	X	1
18	C005-14	Spindle Assembly (Incl items 12, 13, 17, and 22)	O	1
	C157-3	Pitch Horn (Ref)		
19	B289-2	Bolt (includes washer and o-ring)	X	2
	—	Washer (teflon)	O	1
	MS29512-2	O-Ring	X	1
20	MS21042L08	Nut	X	1
21	NAS1352-08-12P	Screw	X	1
22	C158-1	Spindle (Ref)		
23	A257-9	Anti-Seize	X	A/R
24	A257-4	Oil (to fill blade housing)	X	A/R

NOTES * Aluminum skin blades; see Figure 99-23 for shipping crate.
 ** Refer to R44 SL-37 for installation requirements.
 *** Critical part; see R44 Maintenance Manual.

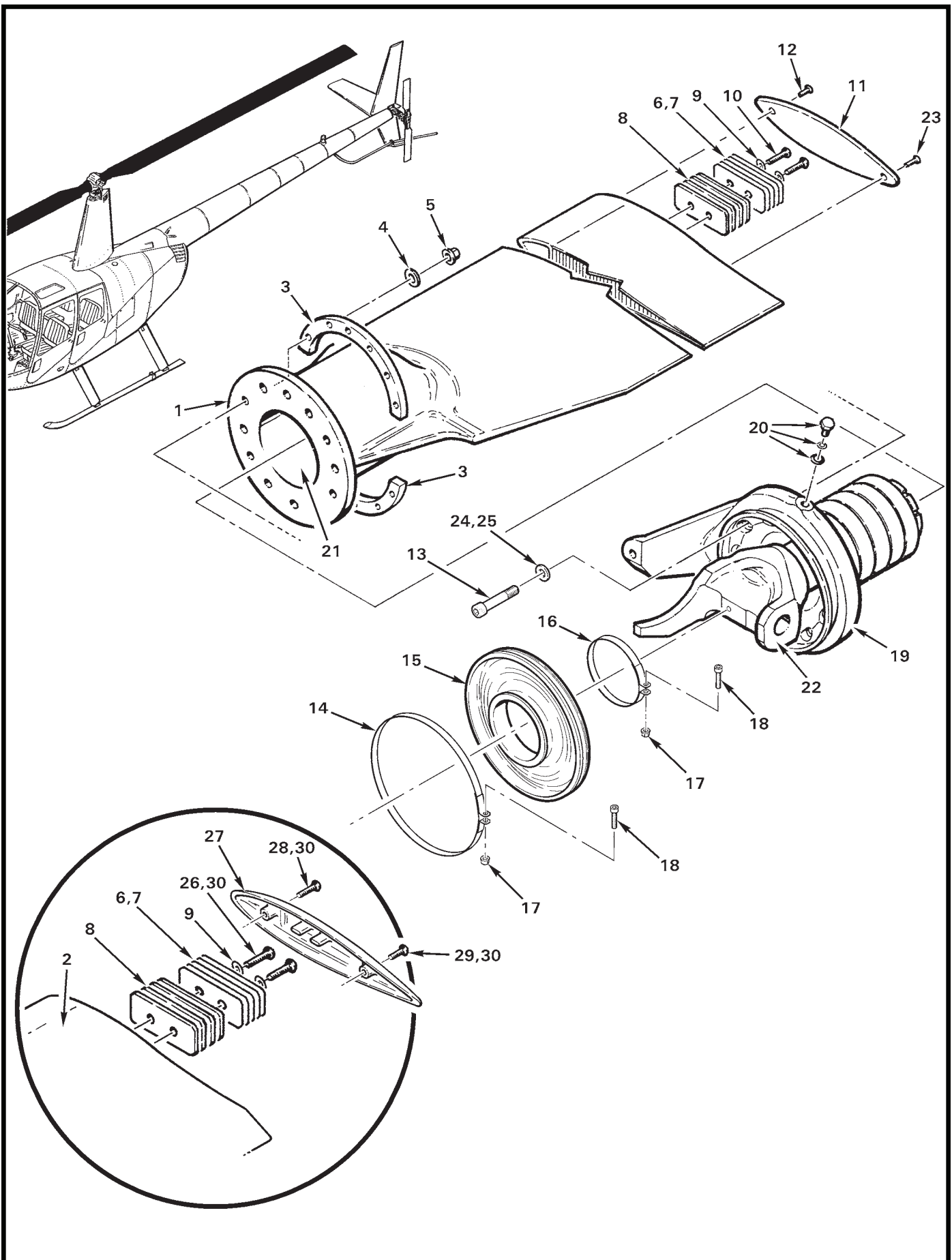

FIGURE AND INDEX NUMBER	PART NUMBER	DESCRIPTION	PARTS AVAIL	QTY PER ASSY
		MAIN ROTOR BLADE ASSEMBLY*		
62-3-1	C005-6**	Main Rotor Blade and Spindle Assembly – Constant Chord (Ref, no longer available. Superseded by C005-12 Main Rotor Blade and Spindle Assembly, see Figure 62-1.)		
	C016-2**	Blade Assembly – Constant Chord (Ref, remove from service per AD 2014-23-16)		
2	C005-8***	Main Rotor Blade and Spindle Assembly – Extended Tab (Ref, no longer available. Superseded by C005-12 Main Rotor Blade and Spindle Assembly, see Figure 62-1.)		
	C016-5***	Blade Assembly – Extended Tab (Ref, remove from service per AD 2014-23-16)		
3	C253-1	Spacer	O	2
4	NAS1149F0563P	Washer	X	12
5	D210-5	Nut	X	12
6	C298-2	Balance Strip (0.040 in. thick steel)	X	A/R
7	C298-3	Balance Strip (0.032 in. thick steel)	X	A/R
8	C298-4	Balance Strip (0.125 in. thick steel)	X	A/R
9	NAS1149F0332P	Washer (or NAS1149F0363P A/R for balance)	X	A/R
10	C722-3	Screw	X	2
11	C300-2	Tip Cover (flat)	X	1
12	MS24694-C54	Screw	X	1
13	C722-1	Screw	O	12
14	C165-2	Clamp Assembly (Incl items 17 and 18)	X	1
15	C156-2	Boot (gray)	X	1
	C156-1	Boot (black)	X	1
16	C165-1	Clamp Assembly (Incl items 17 and 18)	X	1
17	MS21042L08	Nut	X	1
18	NAS1352-08-12P	Screw	X	1
19	C005-9	Spindle Assembly (Incl items 14 thru 16, and 22)	O	1
	C157-3	Pitch Horn (Ref, 16 hole)	O	1
	C157-2	Pitch Horn (Ref, 12 hole)	O	1
20	B289-2	Bolt (includes washer and o-ring)	X	2
	MS29512-2	O-Ring	X	1
21	A257-4	Oil (to fill blade housing)	X	A/R

NOTES * Stainless steel skin blades; see Figure 99-23 for shipping crate.

** Ship S/N 0001 thru 9999.

*** Ship S/N 10001 and subsequent.

Continues

FIGURE AND INDEX NUMBER	PART NUMBER	DESCRIPTION	PARTS AVAIL	QTY PER ASSY
MAIN ROTOR BLADE ASSEMBLY* (Cont'd)				
62-3-22	C158-1	Spindle	O	1
23	MS24694-C51	Screw	X	1
24	NAS1149F0563P	Washer (install using item 25, both sides)	X	12
25	B270-1	Sealant (2-oz tube)	X	A/R
26	C722-3	Screw (install using item 30)	X	2
27	C300-3	Tip Cover (round)	X	1
28	NAS1351N3-16	Screw (install using item 30)	X	1
29	NAS1351N3-12	Screw (install using item 30)	X	1
30	A257-9	Anti-Seize	X	2

NOTES * Stainless steel skin blades; see Figure 99-23 for shipping crate.

Intentionally Blank

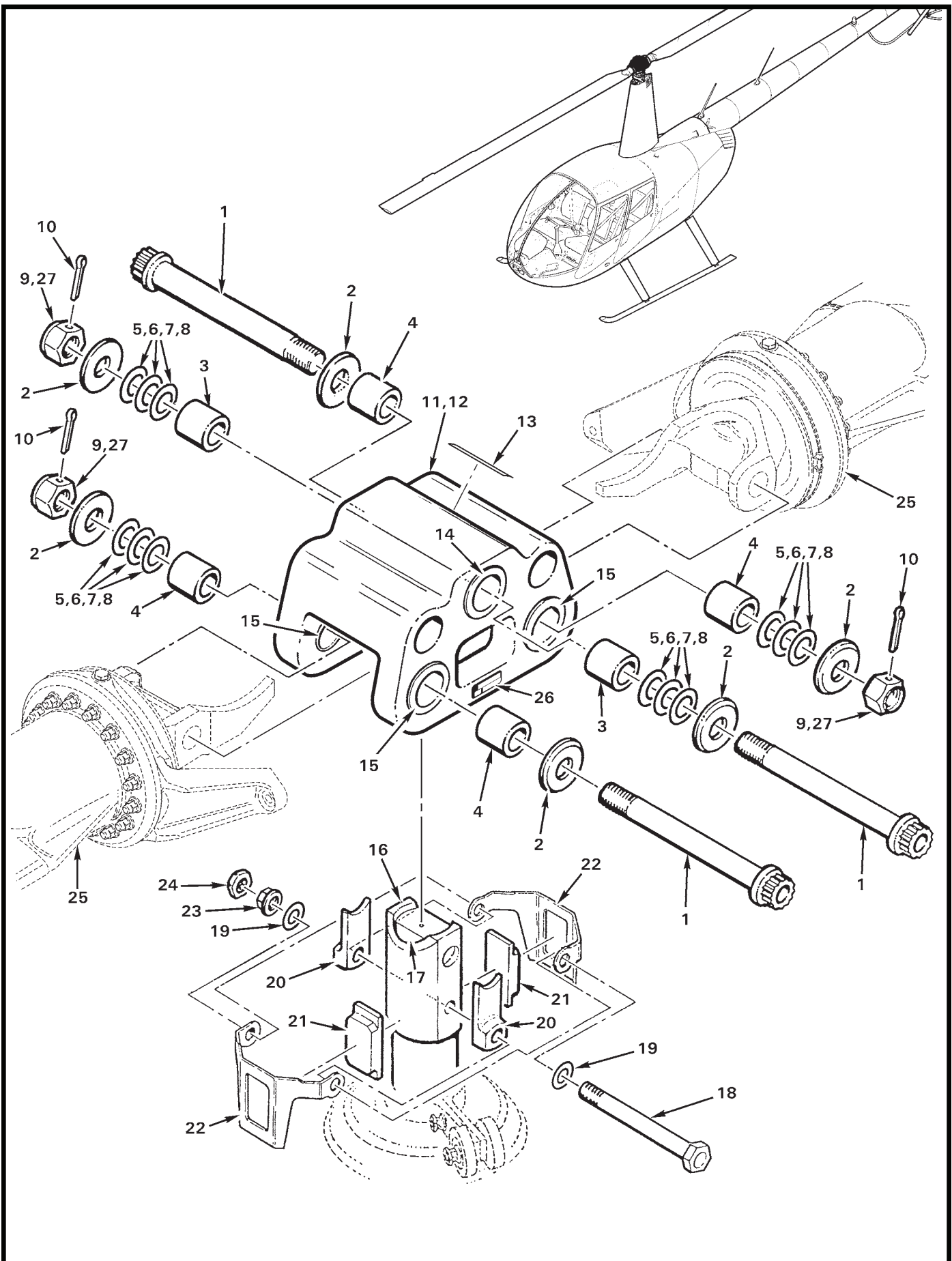

FIGURE AND INDEX NUMBER	PART NUMBER	DESCRIPTION	PARTS AVAIL	QTY PER ASSY
MAIN ROTOR HUB INSTALLATION				
62-7-1	NAS634-105*	Bolt (or MS21250-14105)	X	3
2	C152-1	Thrust Washer	X	6
3	C106-5	Journal-Bearing (length = 1.775 in.)	X	A/R
4	C106-7	Journal-Bearing (length = 1.284 in.)	X	A/R
5	C117-8	Shim-Washer (thickness = 0.012 in.)	X	A/R
6	C117-9	Shim-Washer (thickness = 0.015 in.)	X	A/R
7	C117-10	Shim-Washer (thickness = 0.020 in.)	X	A/R
8	C117-11	Shim-Washer (thickness = 0.025 in.)	X	A/R
9	C189-14*	Nut	X	3
10	MS24665-423	Cotter Pin	X	3
11	C005-4	Hub Assembly (Incl items 12 thru 15, and 26)	X	1
12	C154-1	Hub (Ref, does not include items 14 and 15)	O	1
13	A654-18	Decal "LEVEL HERE"	X	1
14	C648-3**	Bearing (teeter, black)	X	2
15	C648-1**	Bearing (coning, brown)	X	4
16	C251-2	Shaft – Main Rotor (Ref)		
17	C252-1	Spacer – Main Rotor Hub (Ref)	O	1
18	NAS6608-60	Bolt	X	1
19	NAS1149F0832P***	Washer	X	2
20	C150-1	Droop Stop	X	2
21	D151-2	Stop (Replaces D151-1. Use only with D226-2 bracket.)	X	2
22	D226-2	Bracket (Replaces D226-1. Use only with D151-2 stop.)	X	2
23	D210-8	Nut	X	1
24	B330-24	Palnut	X	1
25	C005-12	Blade and Spindle Assembly (Ref, see Figure 62-1)		
26	A651-1	Data Plate (Ref)		
27	A257-9	Anti-seize	X	A/R

NOTES * Install using item 27 on threads.
 ** Requires MT329-6 and MT643-1 tools.
 *** May use item 27 on washer under nut to prevent rotation of item 22 as torque is applied.

Intentionally Blank

CHAPTER 63

MAIN ROTOR DRIVE SYSTEM

<i>Figure</i>	<i>Title</i>	<i>Page</i>
63-1	Main Rotor Gearbox and Mast Assembly	63.0
63-7	Rotor Brake Assembly	63.6
63-11	Knob Assembly – Rotor Brake	63.10
63-13	Forward Flex Plate Installation	63.12
63-15	Clutch Assembly	63.14
63-19	Belt Tension Actuator Installation	63.18
63-23	Cooling Fan, Drive Belts and Lower Sheave	63.22

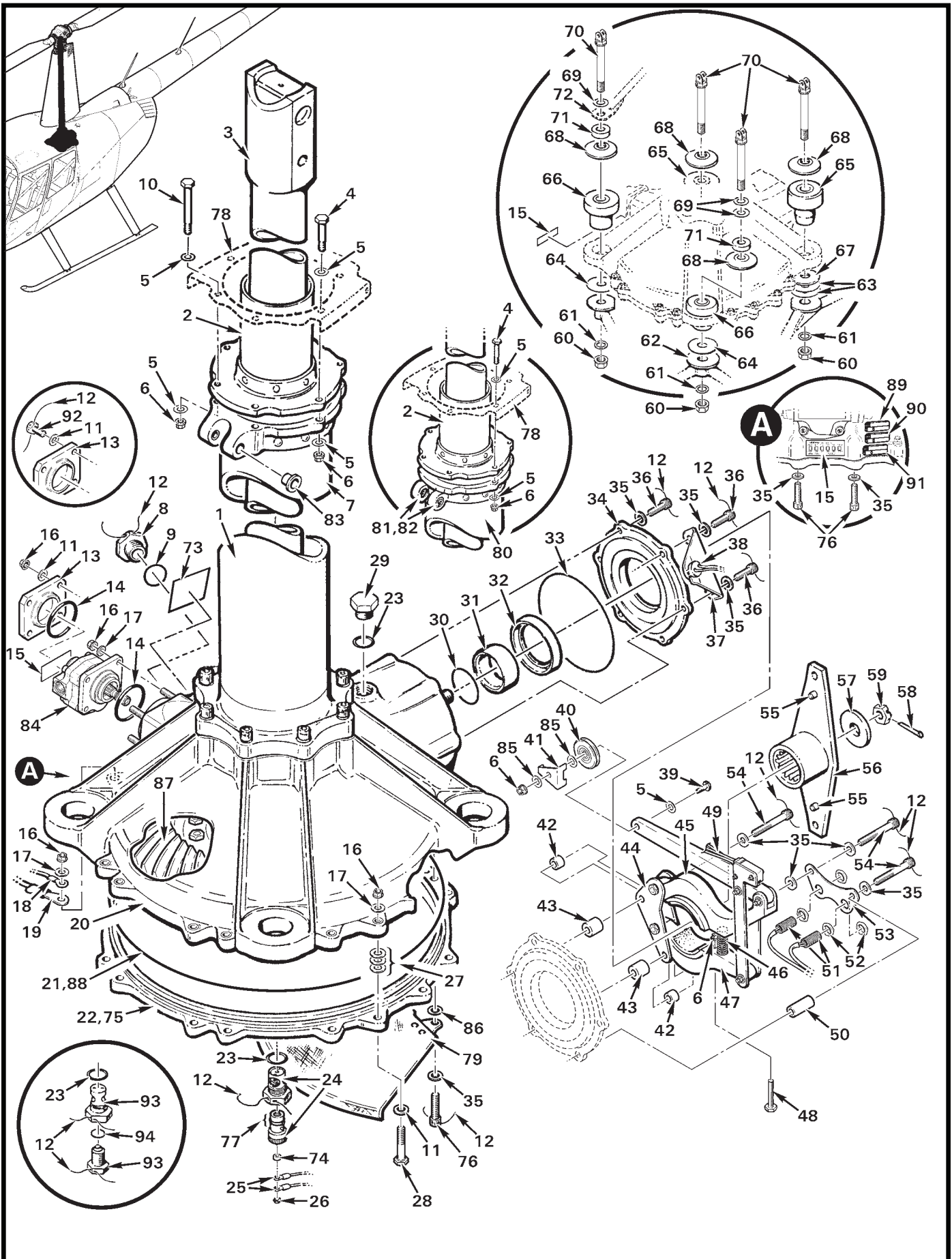

FIGURE AND INDEX NUMBER	PART NUMBER	DESCRIPTION	PARTS AVAIL	QTY PER ASSY
		MAIN ROTOR GEARBOX AND MAST ASSEMBLY		
63-1-1	C006-7*	Main Rotor Gearbox and Mast Assembly (Includes items 3 thru 11, 13 thru 59, 65, 66, 73, 76, 77, 79, and 83 thru 87; also items 8, and 12 thru 14 from Figure 29-17. Includes rotor brake, yoke, slider tube, and hydraulic pump.)	X	1
	C006-8*	Main Rotor Gearbox and Mast Assembly (Includes items 3, 7 thru 9, 11, 13 thru 38, 65, 66, 73, 76, 77, 79, 83, and 87; also items 8, and 12 thru 15 from Figure 29-17. <u>Does not</u> include rotor brake, yoke, slider tube, or hydraulic pump**.)	X	1
	C006-8R*	C006-8 Main Rotor Gearbox and Mast Assembly (overhaul exchange)	X	1
	C006-6*	Main Rotor Gearbox and Mast Assembly (Ship S/N 10001 thru 13838, and ship S/N 0001 thru 2408 with R8206 Upgrade Kit. Includes items 3, 7 thru 9, 11 thru 17, 19 thru 38, 65, 66, 73, 74, 76, 77, 79, 83, and 87; also items 8, and 12 thru 15 from Figure 29-19. <u>Does not</u> include rotor brake, yoke, slider tube, or hydraulic pump**.)	O	1
	C006-1 or -3	Main Rotor Gearbox and Mast Assembly (Ref, no longer available. Superseded by C006-6 assembly.)		
	R8206	C283-3 Mast Tube Upgrade Kit (For ship S/N 0001 thru 9999 with C283-1 Mast Assembly originally installed.)	X	1
2	C284-1	Tube Assembly – Swashplate (Ref)	X	1
3	C251-2	Shaft – Main Rotor Drive	O	1
	C251-1	Shaft – Main Rotor Drive (Ref, not shown. Superseded by C251-2.)		
4	NAS6603-24	Bolt ([6] required with item 80)	X	4
5	NAS1149F0332P	Washer	X	14
6	D210-3	Nut	X	6
7	F283-3	Mast Assembly (Incl item 83)	O	1
8	B563-2	Sight Gage	X	1
9	A215-020	O-Ring	X	1
10	NAS6603-40	Bolt	X	2
11	NAS1149F0432P	Washer	X	12
12	MS20995C32	0.032 in. dia. Safety Wire	X	A/R
13	C257-2	Cover (non-hydraulic ship, or when item 85 is removed)	X	1
14	A215-222	O-Ring	X	1
15	110-4	Telatemp (temperature recorder, 220°–270°F)	X	2
16	D210-4	Nut	X	16
17	A141-11	Washer	X	16
18	B049-3	Harness Assembly	X	1

NOTES * See Figure 99-23 for shipping crate.
 ** For hydraulic R44s only; see Figure 29-17.

Continues

FIGURE AND INDEX NUMBER	PART NUMBER	DESCRIPTION	PARTS AVAIL	QTY PER ASSY
		MAIN ROTOR GEARBOX AND MAST ASSEMBLY (Cont'd)		
63-1-19	C049-2	Harness Assembly	X	1
20	C264-2	Housing (Rev. K and subsequent)	O	1
	C264-1	Housing (Ref; Rev. J and prior, no longer available)		
21	A215-382	O-Ring (use only with C263-2 sump; install using item 88)	X	1
	C215-279	O-Ring (use only with C263-1 sump; install using item 88)	X	1
22	C263-2	Sump (requires A215-222 o-ring)	O	1
	C263-1	Sump (requires C215-279 o-ring)	O	1
23	A215-017	O-Ring	X	2
24	B566-1*	Chip Detector ("quick release", includes items 26, 74, and 77) . .	X	1
25	C049-4	Harness Assembly	X	1
26	—	Nut	O	1
27	AN960PD416L	Washer (or A141-0XX; XX = thickness in thousandths in.) . . .	X	A/R
28	NAS1304-15	Bolt (vary length as required)	X	12
29	AN814-8D	Filler Plug	X	1
30	A215-029	O-Ring	X	1
31	C266-1	Spacer	X	1
32	C966-3	Seal	X	1
33	A215-156	O-Ring	X	1
34	C270-1	End Cover	X	1
35	NAS1149F0463P	Washer	X	17
36	NAS1352-4-12	Screw ([6] required for C006-3 assembly)	X	3
37	C244-1	Bracket	X	1
38	C049-5	Harness Assembly – Overtemp Switch	X	1
39	NAS6603-8	Bolt	X	1
40	MS24566-1B	Pulley (or AN210-1A)	X	1
41	D117-1	Guard	X	1
42	A130-41	Spacer	X	2
43	C130-3	Spacer	X	2
44	C006-2	Rotor Brake Assembly (see Figure 63-7)	X	1
45	D110-1	Arm Assembly – Upper	X	1
46	D774-4	Spring (Associated Spring part no. C0420-063-2000S)	X	1
47	D123-1	Arm Assembly – Lower	X	1
48	NAS428-3-14	Bolt	X	1
49	D049-4	Harness Assembly	X	1
50	C130-4	Spacer	X	1

NOTES * Requires MT054-1 tool to drain gearbox.

Continues

FIGURE AND INDEX NUMBER	PART NUMBER	DESCRIPTION	PARTS AVAIL	QTY PER ASSY
		MAIN ROTOR GEARBOX AND MAST ASSEMBLY (Cont'd)		
63-1-51	B320-2	Sender Assembly (Incl item 52)	X	2
52	—	Nut	O	4
53	D114-1	Bracket	X	1
54	NAS1352-4-30	Screw	X	3
55	B570-1	Magnet Assembly	X	2
56	C908-1	Yoke Assembly (Includes item 55. Coat splines of C146-2 pinion with B270-21 protectant before installing yoke assembly.)	X	1
57	C141-10	Washer	X	1
58	MS24665-283	Cotter Pin	X	1
59	AN320-8	Nut (B270-11 on threads)	X	1
60	D210-10	Nut (install with A257-9 anti-seize on threads)	X	4
61	A141-21	Washer	X	4
62	C020-1	Upper Frame (Ref)		
63	C796-2	Shim (3 maximum per aft pad)	X	A/R
64	A796-1	Shim (3 maximum per fwd pad)	X	A/R
65	C653-3*	Mount	X	2
66	A653-2*	Mount (supersedes A653-1; if replacing a -1 mount replace both forward mounts)	X	2
67	C796-3	Spacer	X	2
68	A267-1	Washer	X	4
69	NAS1149F1063P	Washer	X	A/R
70	A650-4	Fitting	X	4
71	C130-21	Spacer	X	2
72	C345-1	Strut Weldment (Ref)		
73	A654-56	Decal (Ref; main rotor gearbox fill/oil instructions. No longer available. Superseded by F654-13 decal. See Figure 11-5.)		
74	A130-14	Spacer	X	1
75	A257-2LT	Oil – Gearbox (one-liter bottle)	X	A/R
	A257-2	Oil – Gearbox (one-gallon bottle)	X	A/R
76	NAS1352-4-16	Screw	X	6
77	O12C	O-Ring	X	2
78	C261-1	Mast Fairing Assembly (Ref, see also Figure 53-11)	X	2
79	C747-1	Baffle Assembly	X	1
80	C283-1	Mast Assembly (Ref; ship S/N 0001 thru 9999; used with item 81)		

NOTES * Installed with water as lubrication or A257-8 rubber lubricant.

Continues

FIGURE AND INDEX NUMBER	PART NUMBER	DESCRIPTION	PARTS AVAIL	QTY PER ASSY
MAIN ROTOR GEARBOX AND MAST ASSEMBLY (Cont'd)				
63-1-81	B115-1	Bearing (install using item 82)	X	2
82	B270-10	Adhesive	X	A/R
83	C648-2	Bearing – Journal	X	2
84	D500-1	Pump (Ref, see Figure 29-19 for installation)		
85	NAS1149D0316J	Washer	X	2
86	NAS1149F0432P	Washer (or NAS1149F0463P to fill gap)	X	A/R
87	C146-5	Gear Set	O	1
	C146-1	Gear Set (Ref, earlier R44's)		
88	A257-19	Lubricant	X	1
89	—	Data Plate (C146 Gear Set, Ref)		
90	—	Data Plate (MRGB Housing, Ref)		
91	—	Data Plate (C006 MRGB, Ref)		
* * *				
92	MS20074-04-04	Bolt (earlier non-hydraulic R44s)	X	4
93	A7260	Chip Detector (Ref; no longer available)		
94	AS111	O-Ring (use only with item 92)	X	1
95	C647-1	Bearing (main rotor shaft upper bearing, not shown)	O	1

NOTES

Intentionally Blank

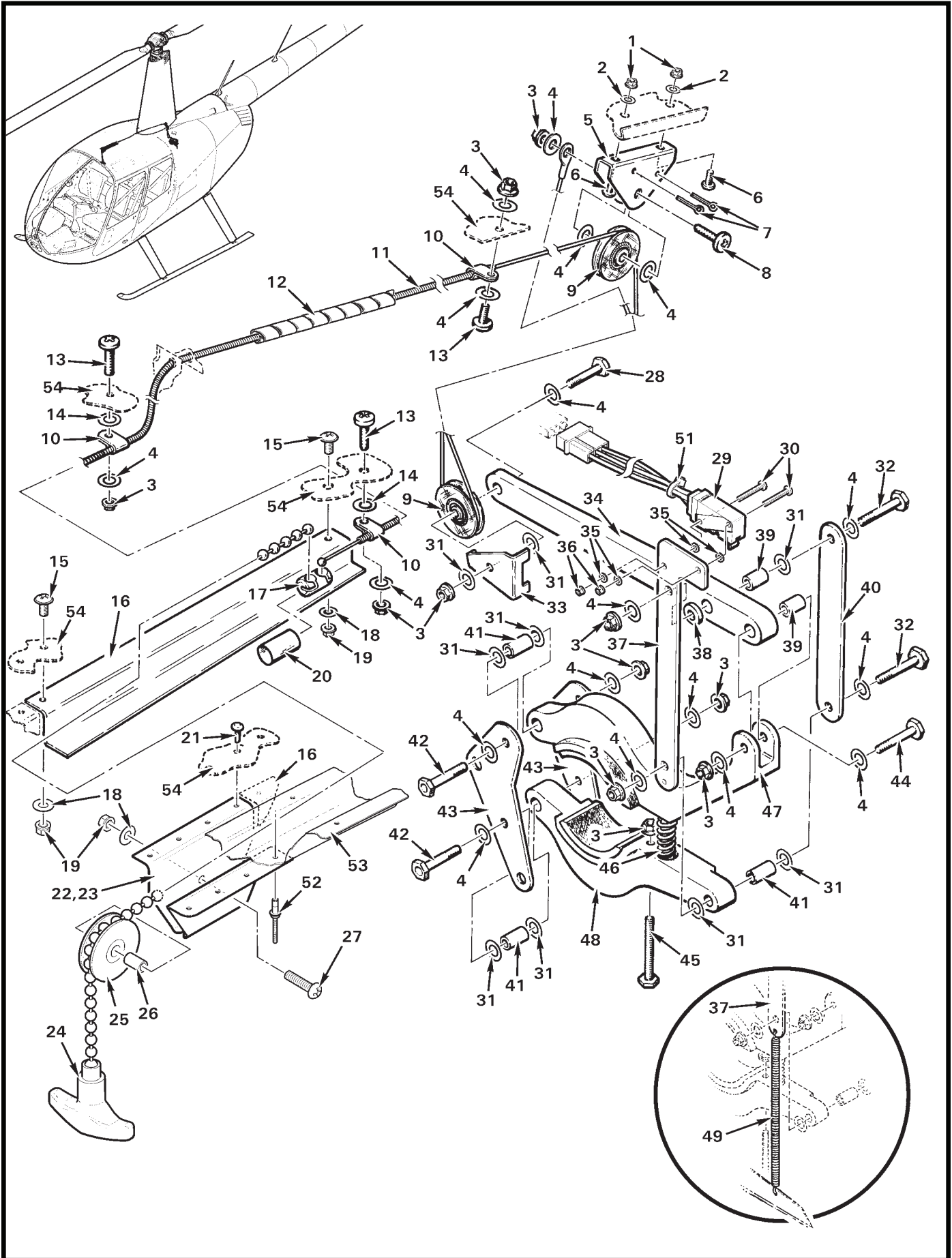

FIGURE AND INDEX NUMBER	PART NUMBER	DESCRIPTION	PARTS AVAIL	QTY PER ASSY
ROTOR BRAKE ASSEMBLY				
63-7-1	MS21042L06	Nut	X	2
2	NAS620-6	Washer	X	2
3	MS21042L3	Nut	X	10
4	NAS1149F0332P	Washer	X	17
5	B157-1	Mount	X	1
6	MS35206-228	Screw	X	2
7	MS24665-134	Cotter Pin	X	2
8	MS27039C1-11	Screw	X	1
9	MS24566-1B	Pulley (supersedes AN210-1A)	X	2
10	AN742-3	Clamp	X	3
11	D126-1	Cable Assembly	X	1
12	B161-4	Spirap	X	A/R
13	MS27039C1-07	Screw	X	3
14	NAS620-10L	Washer	X	2
15	AN526C832R6	Screw	X	2
16	D117-2	Guard	X	1
17	B125-2	Connector	X	1
18	NAS1149FN816P	Washer	X	3
19	MS21042L08	Nut	X	3
20	B158-8	Heat Shrink	X	A/R
21	MS20470AD4	Rivet	X	4
22	D118-1	Bracket Assembly (Includes MS21071L06 nutplate. Seal around edges with item 23.)	X	1
23	B270-2	Sealant – Metal (silver)	X	A/R
24	B033-6	Knob Assembly (includes knob and chain)	X	1
25	BP4100	Pulley	X	1
26	A130-34	Spacer	X	1
27	MS27039C0812	Screw	X	1
28	NAS6603-8	Bolt	X	1
29	D049-4	Harness Assembly (includes housing, pins, wires, and switch)	X	1
30	MS35206-219	Screw	X	2
31	NAS1149D0316J	Washer	X	9
32	NAS6603-12	Bolt	X	2
33	D117-1	Guard	X	1
34	D112-1	Lever	X	1

NOTES

Continues

FIGURE AND INDEX NUMBER	PART NUMBER	DESCRIPTION	PARTS AVAIL	QTY PER ASSY
ROTOR BRAKE ASSEMBLY (Cont'd)				
63-7-35	NAS620-4	Washer	X	4
36	MS21042L04	Nut	X	2
37	D113-2	Link	X	1
38	A141-27	Washer	X	1
39	A130-40	Spacer	X	2
40	D113-1	Link	X	1
41	A130-39	Spacer	X	3
42	NAS6603-11	Bolt	X	2
43	D111-1	Bracket	X	2
44	NAS6603-10	Bolt	X	1
45	NAS428-3A-14	Bolt	X	1
46	D774-4	Spring (alternate part no. C0420-063-2000S)	X	1
47	D110-1	Arm Assembly	X	1
48	D123-1	Arm Assembly	X	1
49	E0240-037-3500S	Spring	X	1
50	C006-2	Rotor Brake Assembly (Incl items 3 [7], 4 [11], 9 [1], and 28 thru 48)	X	1
51	MS3367-5-9	Ty-Rap	X	A/R
52	NAS9301B-4-02	Rivet	X	4
53	C238-23	Support (Ref)		
54	C273-1	Roof (Ref)		

NOTES

Intentionally Blank

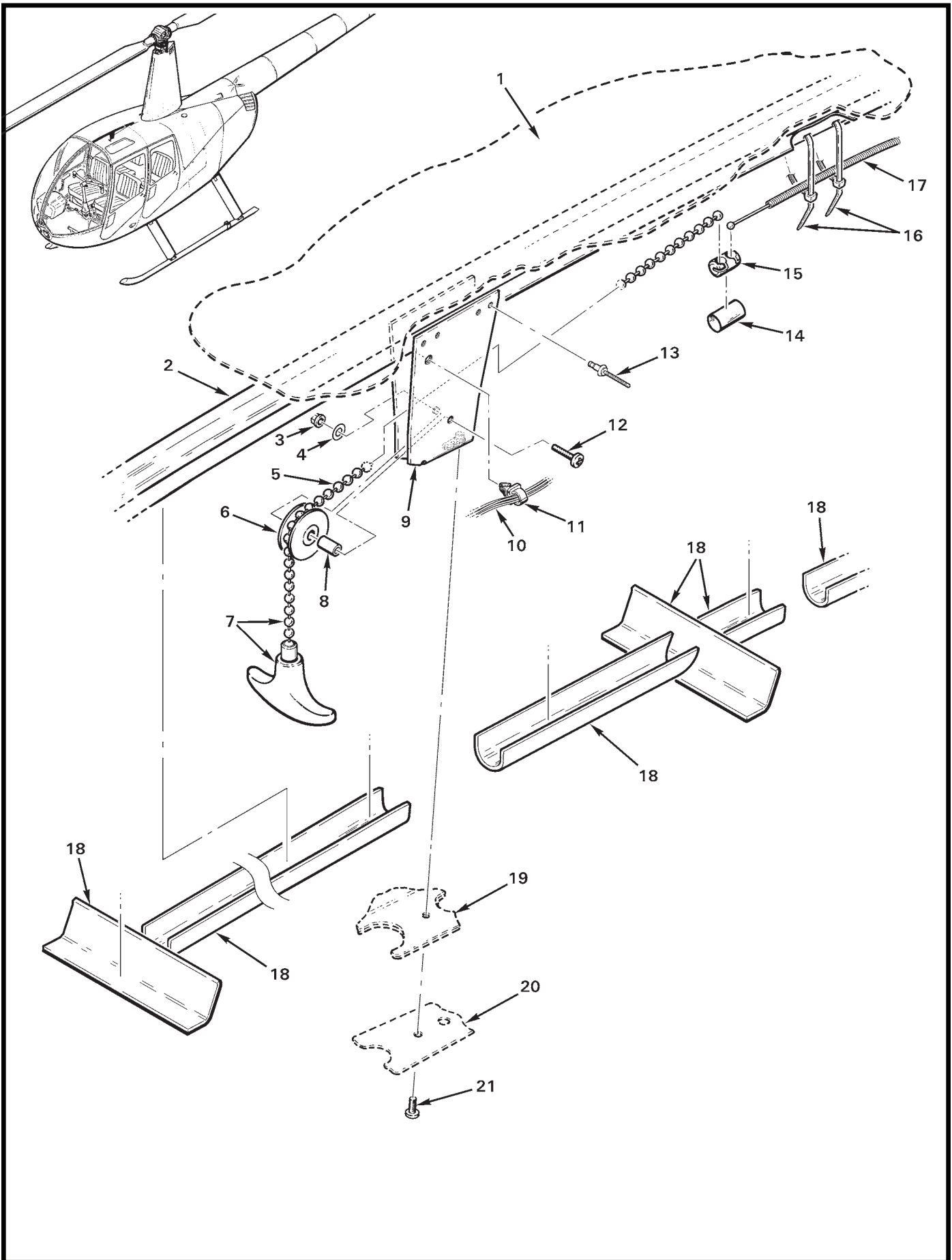

FIGURE AND INDEX NUMBER	PART NUMBER	DESCRIPTION	PARTS AVAIL	QTY PER ASSY
		KNOB ASSEMBLY - ROTOR BRAKE*		
63-11-1	C273-1	Roof Panel (Ref)		
2	C238-23	Support - Roof (Ref)		
3	MS21042L08	Nut	X	1
4	NAS1149FN816P	Washer	X	1
5	01960	Bead Chain	X	1
6	BP4100	Pulley	X	1
7	B033-6	Knob Assembly - Rotor Brake (Incl item 5)	X	1
8	A130-34	Spacer	X	1
9	D122-1	Bracket Assembly (includes nutplate)	X	1
10	—	Wire Harness (Ref)		
11	220-242400-09	Clip	X	1
12	MS27039C0812	Screw	X	1
13	NAS9301B-4-02	Rivet	X	8
14	B158-8	Heat Shrink	X	A/R
15	B125-2	Connector	X	1
16	MS3367-5-9	Ty-Rap	X	2
17	D126-1	Cable Assembly (Ref, see Figure 63-7)		
18	5541K11	Pipe Wrap (self-adhesive)	X	A/R
19	D796-1	Duct Assembly (Ref, see Figure 21-31)		
20	D122-6	Plate (Ref, see Figure 21-33)		
21	MS27039C0806	Screw (Ref, see Figure 21-33)		

NOTES * Air-conditioned ships.

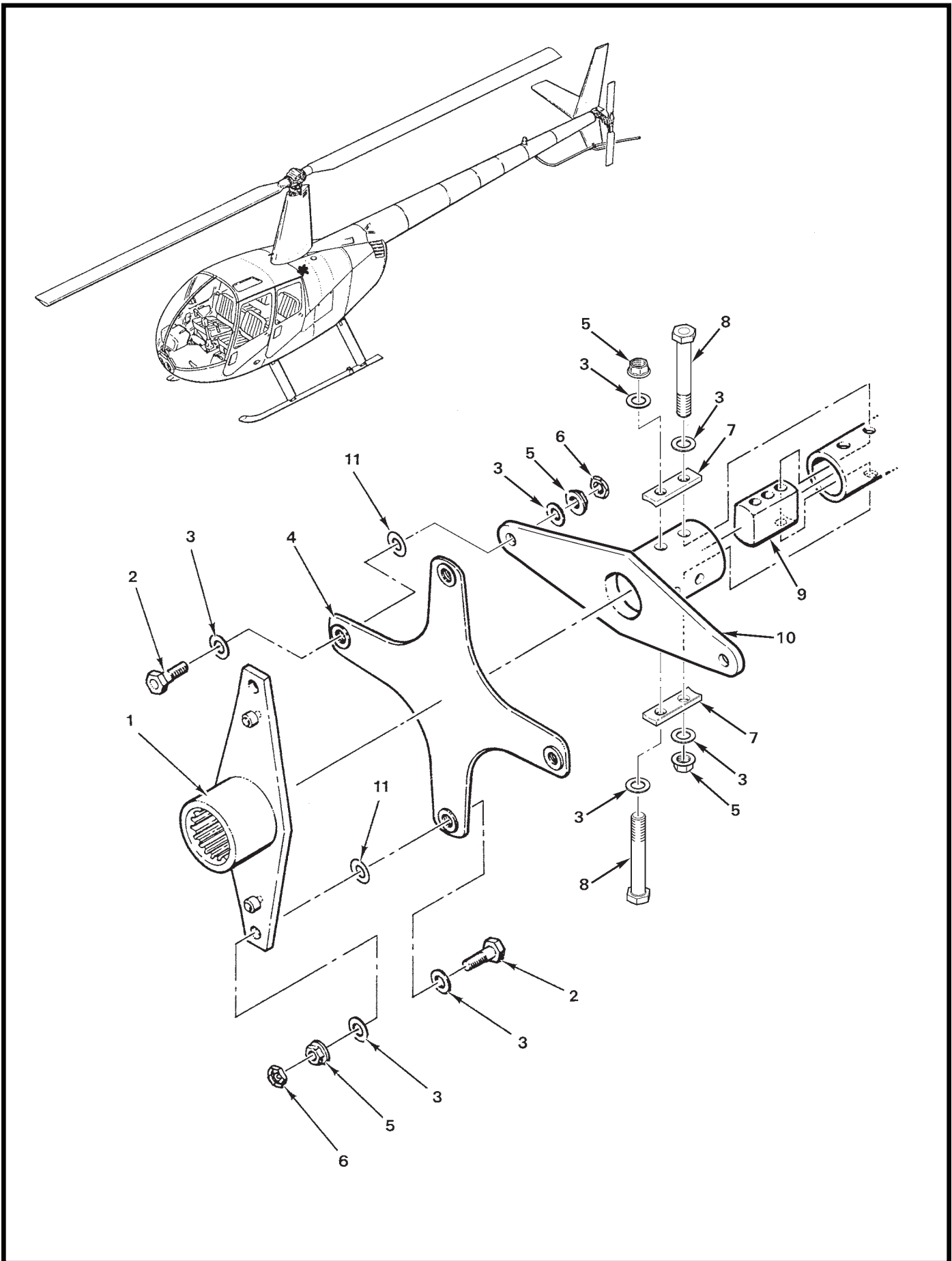

FIGURE AND INDEX NUMBER	PART NUMBER	DESCRIPTION	PARTS AVAIL	QTY PER ASSY
FORWARD FLEX PLATE INSTALLATION				
63-13-1	C908-1	Yoke (Ref)		
2	NAS6606-5	Bolt	X	4
3	NAS1149F0632P	Washer	X	12
4	C947-1	Flex Plate Assembly	X	1
5	D210-6	Nut	X	6
6	B330-19	Palnut	X	4
7	C191-1	Block	X	1
8	NAS6606-31	Bolt	X	2
9	C553-1	Block	X	1
10	C907-1	Yoke (shaft length – 2.76 in.)	X	1
	C907-2	Yoke (shaft length – 2.90 in.)	X	1
11	NAS1149F0632P*	Washer	X	A/R

NOTES * Determine shim washers required for sheave alignment per R44 Maintenance Manual Section 7.230.

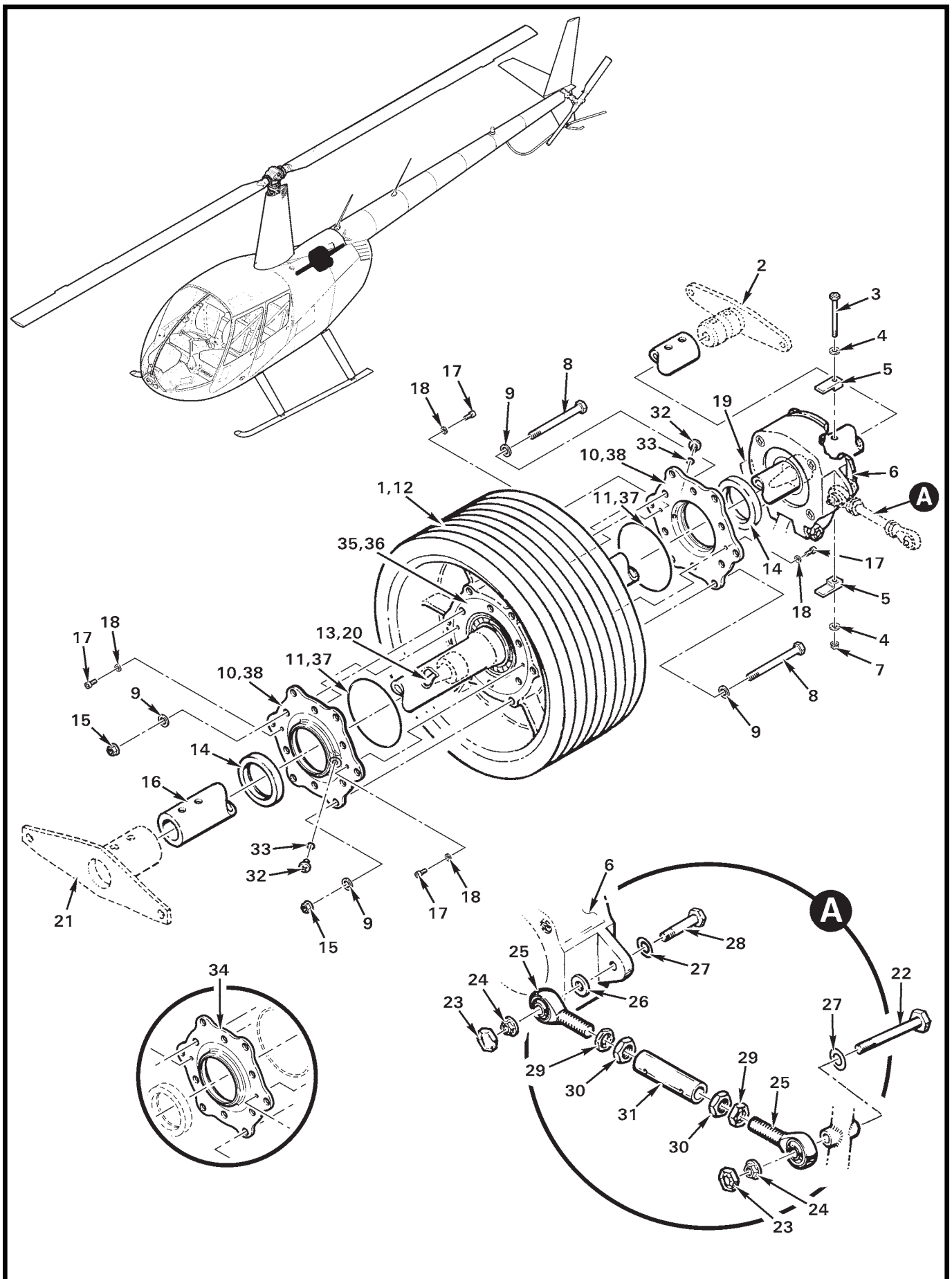

FIGURE AND INDEX NUMBER	PART NUMBER	DESCRIPTION	PARTS AVAIL	QTY PER ASSY
		CLUTCH ASSEMBLY		
63-15-1	C018-2*	Clutch Assembly (Anodized sheave. Includes items 3 thru 11, 12 [C170-2], 13 thru 20, 32, 33 and C188-3 sprag clutch.)	X	1
	C018-2R	C018-2 Clutch Assembly (overhaul exchange; includes new C166-4 shaft)	X	1
	C018-3*	Clutch Assembly (Metalized sheave. Includes items 3 thru 11, 12 [C170-3], 13 thru 20, 32, 33 and C188-3 sprag clutch.)	X	1
	C018-3R	C018-3 Clutch Assembly (overhaul exchange; includes new C166-4 shaft)	X	1
2	C195	Yoke (Ref, see Figure 65-1)		
3	NAS6603-28	Bolt	X	1
4	NAS1149F0332P	Washer	X	2
5	C191-5	Stop	X	2
6	C184-2	Bearing Assembly – Upper	X	1
	C184-2R	C184-2 Bearing Assembly – Upper (overhaul exchange)	X	1
7	MS21042L3	Nut	X	1
8	NAS6605-42	Bolt	X	12
9	NAS1149F0532P	Washer	X	24
10	C168-5	Retainer (supersedes item 34; includes items 32 and 33)	X	2
11	A215-152	O-Ring (used <u>only</u> with item 35)	X	2
12	C170-2	Sheave – Upper (anodized)	O	1
	C170-3	Sheave – Upper (metalized)	O	1
13	C967-1	Plug	O	2
14	C966-5	Seal	X	2
15	MS21042L5	Nut	X	12
16	C166-4	Shaft – Clutch (Ref)	O	1
17	NAS1352-08LE6P	Screw	X	4
18	NAS620-8	Washer	X	4
19	110-3	Telatemp (temperature recorder 180°-230°F)	X	1
20	A257-4	Oil – Type “A” ATF (Dexron III)	X	A/R
21	C907	Yoke (Ref, see Figure 63-13)		
22	NAS6604-21	Bolt	X	1
23	B330-13	Palnut	X	2
24	D210-4	Nut	X	2

NOTES * Originally installed on ship S/N 1902 and subsequent, and S/N 12323 and subsequent. Refer to Service Bulletin SB-79 to retrofit earlier clutch assemblies with serviceable retainers.

Continues

FIGURE AND INDEX NUMBER	PART NUMBER	DESCRIPTION	PARTS AVAIL	QTY PER ASSY
CLUTCH ASSEMBLY (Cont'd)				
63-15-25	A101-4	Rod End	X	2
26	MS20002-4	Washer	X	1
27	NAS1149F0432P	Washer	X	2
28	NAS6604-11	Bolt	X	1
29	B330-16	Palnut	X	2
30	AN316-5R	Nut	X	2
31	A344-2	Strut	X	1
32	B289-3	Screw (Incl item 33)	X	2
33	—	O-Ring	O	2
34	C168-4	Retainer (Ref; no longer available)		
35	C167-5	Housing (Ref)		
36	C167-3	Housing (Ref)		
37	A215-042	O-Ring (used <u>only</u> with item 36)	X	2
* * *				
38	KI-202	Retainer Upgrade Kit (Ref; includes items 10, 14, 32, and 37)	X	1
NOTES				

Intentionally Blank

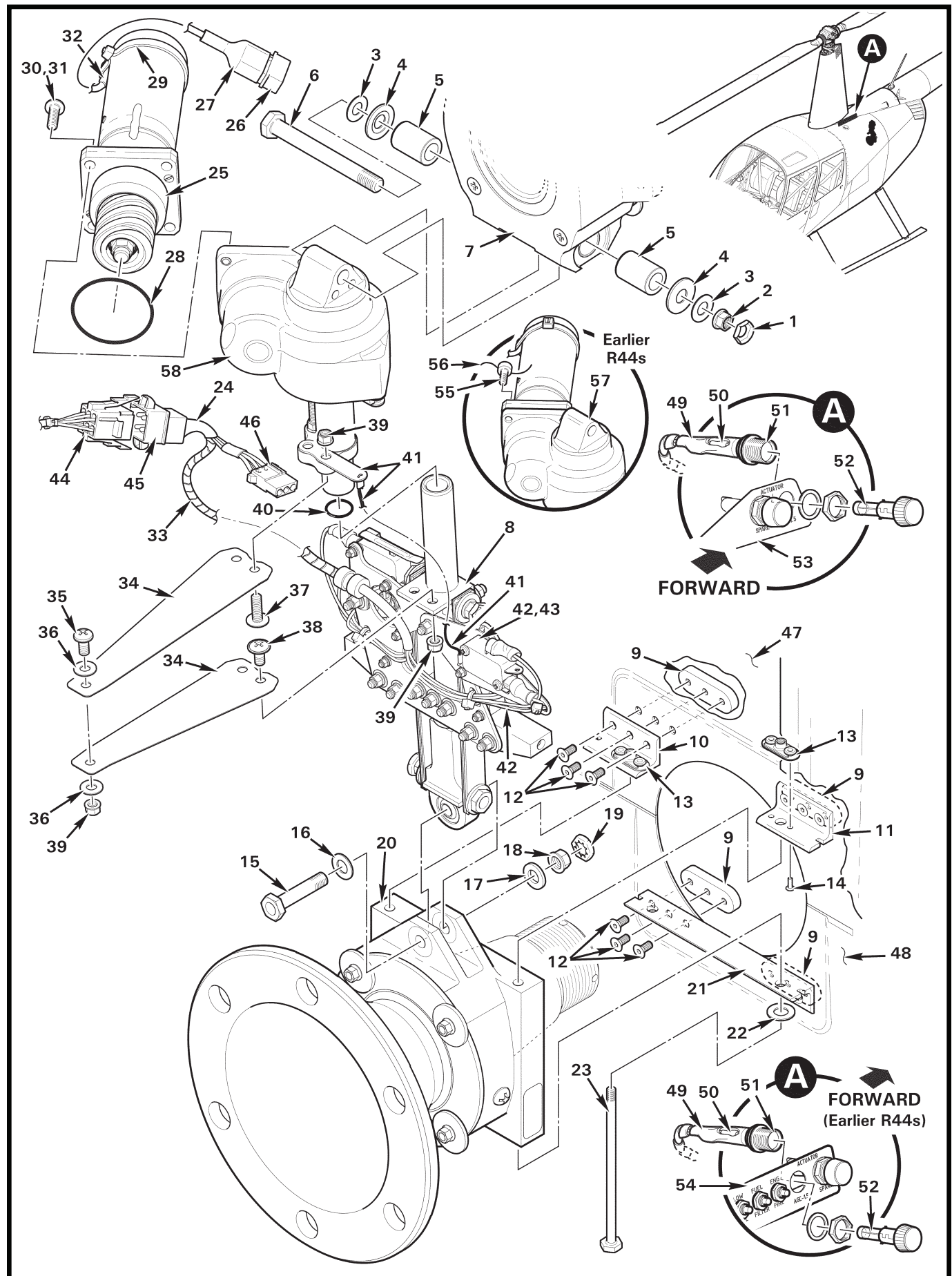

FIGURE AND INDEX NUMBER	PART NUMBER	DESCRIPTION	PARTS AVAIL	QTY PER ASSY
BELT TENSION ACTUATOR INSTALLATION				
63-19-1	B330-16	Palnut	X	1
2	D210-5	Nut	X	1
3	NAS1149F0532P	Washer	X	2
4	D214-2	Washer (install with counterbore toward journal)	X	2
5	C105-2	Journal	X	2
6	NAS6605-38	Bolt	X	1
7	C184-2	Upper Bearing Assembly (Ref, see Figure 63-15)		
8	C051-1	Actuator Assembly – Belt Tension (14-volt ships; includes items 25 [D276-1], 28 thru 31, 34 thru 42, and 57 or 58)	X	1
	C051-1R	C051-1 Actuator Assembly – Belt Tension (overhaul exchange; R7624 core deposit required)	X	1
	C051-2	Actuator Assembly – Belt Tension (28-volt ships; includes items 25 [D276-3], 28 thru 31, 34 thru 42, and 57 or 58)	X	1
	C051-2R	C051-2 Actuator Assembly – Belt Tension (overhaul exchange; R7539 core deposit required)	X	1
9	A185-7	Plate	X	4
	A185-3*	Plate	X	4
10	A185-8	Bracket	X	1
	A185-2*	Bracket	X	1
11	A185-9	Bracket	X	1
	A185-5*	Bracket	X	1
12	91266A192	Screw	X	12
	MS20470AD5*	Rivet	X	12
13	MS21075L3E	Nutplate	X	2
14	MS20426AD3	Rivet	X	4
15	NAS6604-13	Bolt	X	1
16	NAS1149F0432P	Washer	X	1
17	NAS1149F0463P	Washer	X	1
18	D210-4	Nut	X	1
19	B330-13	Palnut	X	1
20	C007-5	Shaft and Bearing Assembly (includes C181-3 lower bearing)	X	1
	C181-3	Bearing Assembly (Ref)		
21	A185-6	Bracket	X	1
	A185-1	Bracket	X	1
22	NAS620-10L	Washer	X	2
23	AN3-41A	Bolt	X	2

NOTES * Does not include item 13, refer to R44 Service Letter SL-61B.

Continues

FIGURE AND INDEX NUMBER	PART NUMBER	DESCRIPTION	PARTS AVAIL	QTY PER ASSY
BELT TENSION ACTUATOR INSTALLATION (Cont'd)				
63-19-24	B158-12	Heat Shrink (around item 45)	X	A/R
25	D276-1	Gearmotor Assembly (14-volt ships; includes items 26, 27, and 32)	X	1
	D276-3	Gearmotor Assembly (28-volt ships; includes items 26, 27, and 32)	X	1
26	B263-12	Housing (14-volt ships)	X	1
	B263-14	Housing (28-volt ships)	X	1
	B263-1	Pin	X	2
27	B158-8	Heat Shrink (14-volt ships)	X	A/R
	B158-408	Heat Shrink (28-volt ships)	X	A/R
28	A215-029	O-Ring (lubricate with A257-1 grease)	X	1
29	MS3367-7-0	Ty-Rap	X	1
30	MS27039C1-09	Screw (install using item 31)	X	4
31	A257-9	Anti-Seize	X	A/R
32	B158-704	Heat Shrink (1.1 ± 0.2-inch long)	X	A/R
33	B161-4	Spirap	X	A/R
34	A510-2	Scissor	X	2
35	MS27039C1-06	Screw	X	1
36	NAS1149F0332P	Washer	X	2
37	AN525-10R9	Screw	X	2
38	AN525-10R6	Screw	X	2
39	D210-3	Nut	X	5
40	A215-016	O-Ring (install using A257-1 grease)	X	1
41	A482-1	Actuator Assembly	X	1
42	C053-2	Switches Assembly (Incl items 24, 33, 43 [4], 45, and 46)	X	1
43	V3-1001	Switch (use B158-2 or -3 [item 50] around terminals)	X	4
	B158-2	Heat Shrink	X	A/R
44	C859	Harness Assembly (Ref)		
45	B263-18	Housing (see Figure 96-55)	X	1
	B263-1	Pin	X	1
	B263-3	Pin	X	4
	A15A	Diode	X	1
46	B263-15	Housing	X	1
	B263-2	Socket	X	2
47	C236-1	Scroll Assembly (Ref; upper)		

NOTES

Continues

FIGURE AND INDEX NUMBER	PART NUMBER	DESCRIPTION	PARTS AVAIL	QTY PER ASSY
BELT TENSION ACTUATOR INSTALLATION (Cont'd)				
63-19-48	C236-2	Scroll Assembly (Ref; lower, without air conditioning)		
	C236-5	Scroll Assembly (Ref; lower, with air conditioning)		
49	B158-8	Heat Shrink (around fuse holder)	X	A/R
50	B158-3	Heat Shrink (around wires, terminal)	X	A/R
51	D262-11	Fuse Holder	X	2
52	AGC-3	Fuse (3 amp; for 14-volt ships, [1] spare)	X	2
	AGC-1.5	Fuse (1.5 amp; for 28-volt ships, [1] spare)	X	2
53	A938-9	Mount (Ref)		
54	A938-3	Mount – Test Switches (Ref; 14-volt)		
	A938-5	Mount – Test Switches (Ref; 28-volt)		
55	AN503-10-10	Screw	X	4
56	MS20995C32	0.032 in. dia. Safety Wire	X	A/R
57	C501-1	Housing	O	1
58	C501-2	Housing	O	1
NOTES				

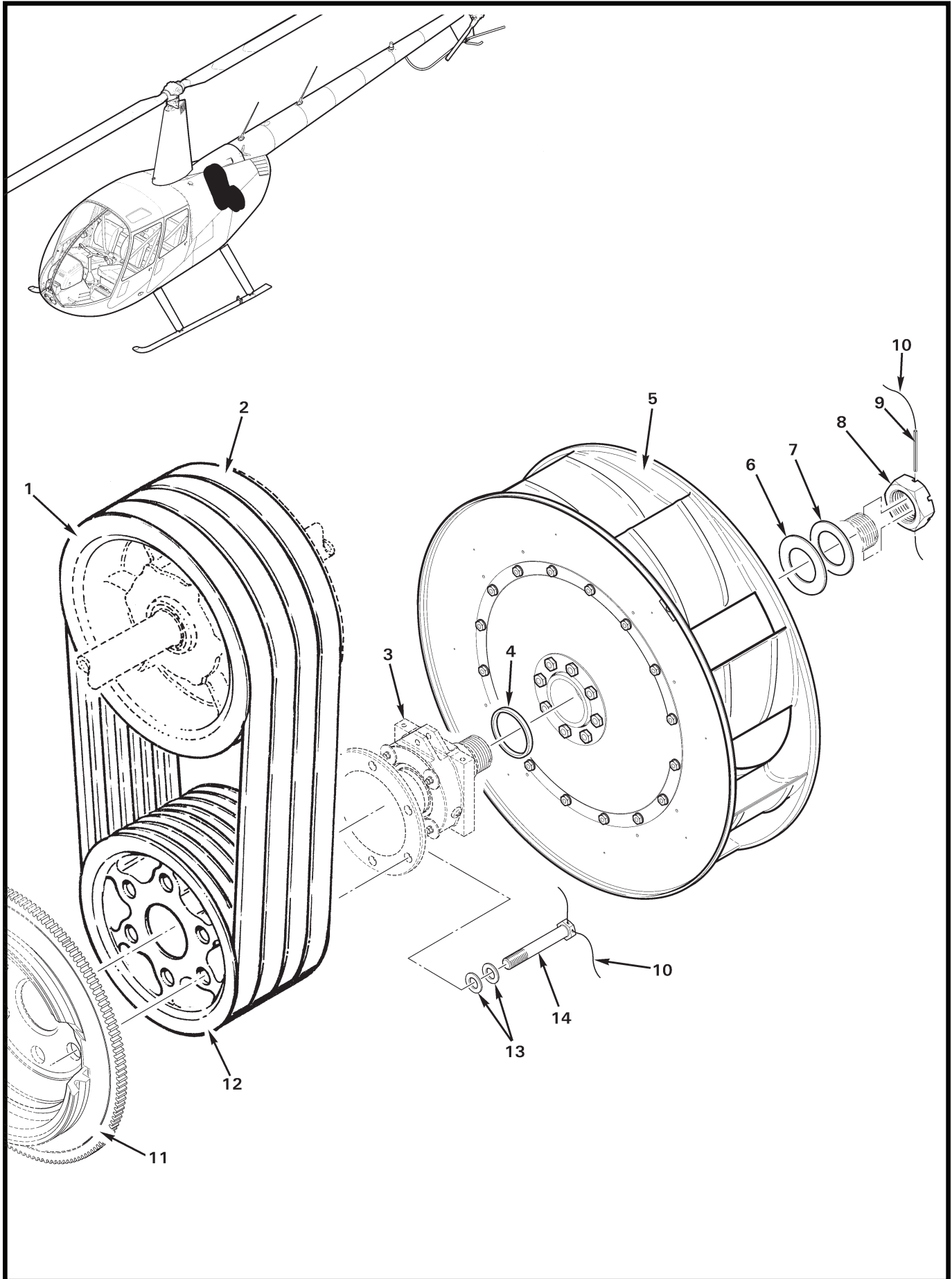

FIGURE AND INDEX NUMBER	PART NUMBER	DESCRIPTION	PARTS AVAIL	QTY PER ASSY
COOLING FAN, DRIVE BELTS AND LOWER SHEAVE				
63-23-1	C018	Clutch Assembly (Ref, see Figure 63-15)		
2	A190-3	V-Belts (matched set of four banded belts)	X	1
3	C007	Shaft and Bearing Assembly (Ref, see Figure 63-19)		
4	C192-1	Spacer	X	1
5	D174-2	Fanwheel Assembly	X	1
	D174-2R	D174-2 Fanwheel Assembly (overhaul exchange)	X	1
6	MS20002-24	Washer (against hub)	X	1
7	NAS1149F2432P	Washer (as required to install item 9)	X	A/R
8	C182-1	Nut.	X	1
9	B350-3	Spring Pin	X	1
10	MS20995C41	0.041 in. dia. Safety Wire	X	A/R
11	31M22972*	Engine Starter Ring Gear Assembly (supersedes LW-16471* and 31M21951* starter ring gear assembly used on O-540 engine)	X	1
12	C493-1	Sheave – Lower	X	1
13	NAS1149F0863P	Washer	X	12
14	NAS6608H42	Bolt	X	6

NOTES * Lycoming part no.

Intentionally Blank

CHAPTER 64

TAIL ROTOR

<i>Figure</i>	<i>Title</i>	<i>Page</i>
64-1	Tail Rotor Assembly	64.0
64-5	Tail Rotor Assembly	64.4
64-9	Hub Assembly	64.8

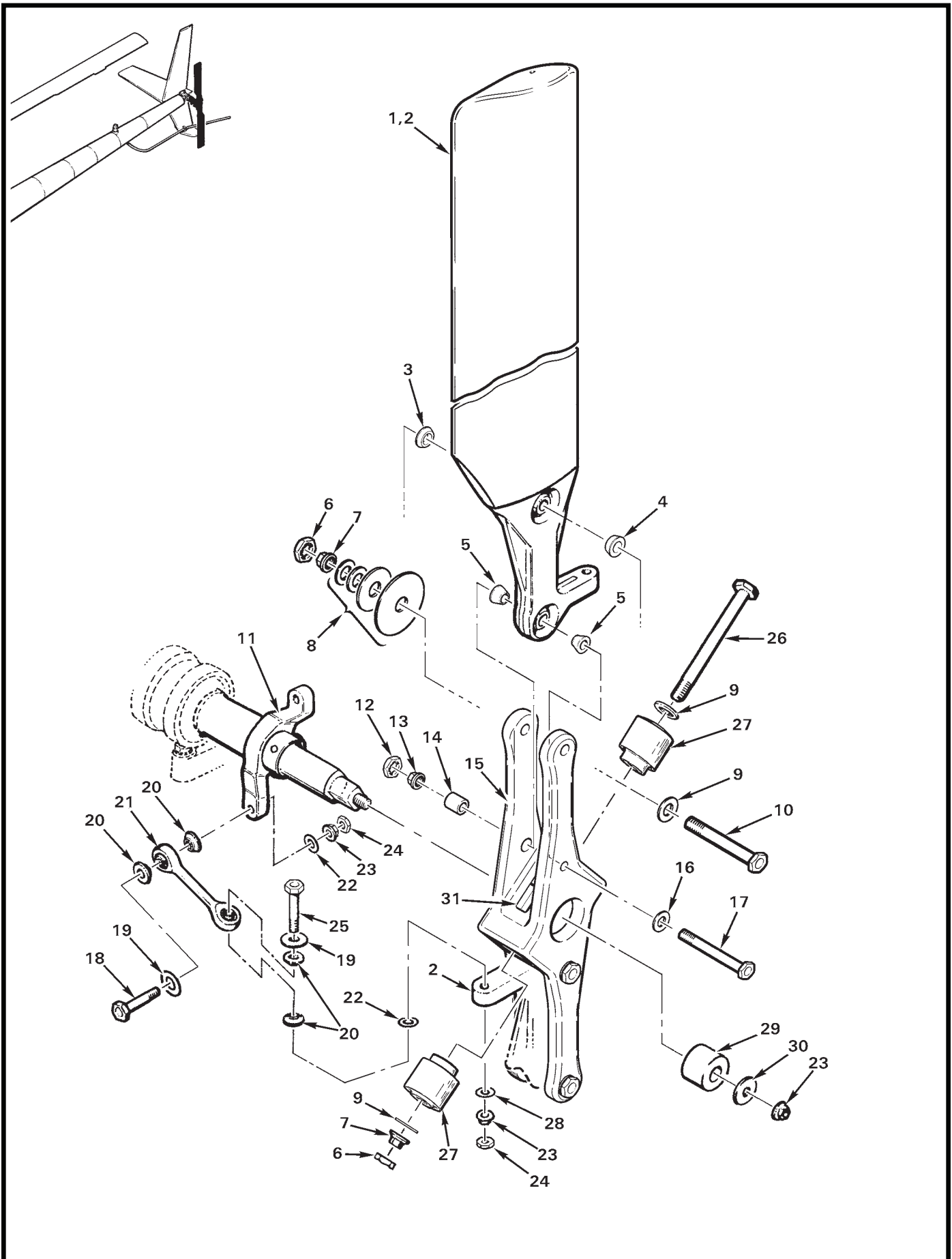

FIGURE AND INDEX NUMBER	PART NUMBER	DESCRIPTION	PARTS AVAIL	QTY PER ASSY
TAIL ROTOR ASSEMBLY				
64-1-1	C008-9	Tail Rotor Assembly (Incl items 2 thru 10, 12 thru 17, 19, 24, 25, and 30)	X	1
2	C029-3*	Blade Assembly	O	2
3	F137-1	Spacer (0.158 inch long)	X	2
4	F137-2	Spacer (0.231 inch long)	X	2
5	C137-1	Spacer (0.345 inch long)	X	4
6	B330-19	Palnut	X	2
7	D210-6	Nut	X	3
8	NAS1149F0663P	Washer (or NAS1149F0632P NAS1149F0663P, NAS1149D0632J, NAS1149D0663J, C141-23, or C141-24; any combination as required for balance; [4] required for each blade)	X	8
9	NAS1149F0632P	Washer	X	4
10	NAS6606-36	Bolt	X	2
11	C031-1	Pitch Control Assembly (Ref, see also Figure 65-7)		
12	B330-16	Palnut	X	2
13	D210-5	Nut	X	2
14	C138-2	Bushing (install with wet primer)	X	2
15	G062-1	Hub Assembly (Incl items 6, 7, 9, 26, and 27)	X	1
	G062-2	Hub	O	1
16	NAS1149F0532P	Washer	X	2
17	NAS6605-34	Bolt	X	2
18	NAS6604-16	Bolt	X	2
19	A214-3	Washer (0.688 inch dia.)	X	4
20	A115-1	Spacer – Rod End	X	8
21	B345-4	Link	X	2
22	NAS1149F0432P	Washer	X	4
23	D210-4	Nut	X	5
24	B330-13	Palnut	X	4
25	NAS6604-17 to -22	Bolt (increase length to add washer to weights)	X	2
26	NAS6606-53	Bolt	X	1
27	B361-2**	Bearing	X	2
28	NAS1149F0463P	Washer (or NAS1149F0432P, NAS1149F0463P, A141-14, NAS1149D0432J, NAS1149D0463J, or A214-3 as required for balance)	X	A/R
29	C119-2	Bumper (black)	X	1

NOTES * Critical part; see R44 Maintenance Manual.
 ** MT556-11 tools required to install bearing. See Figure 99-19.

Continues

FIGURE AND INDEX NUMBER	PART NUMBER	DESCRIPTION	PARTS AVAIL	QTY PER ASSY
TAIL ROTOR ASSEMBLY (Cont'd)				
64-1-30 31	A141-14 A651-1	Washer (0.750 in. dia.) Data Plate (Ref)	X	1
NOTES				

Intentionally Blank

FIGURE AND INDEX NUMBER	PART NUMBER	DESCRIPTION	PARTS AVAIL	QTY PER ASSY
TAIL ROTOR ASSEMBLY				
64-5-1	C008-4*	Tail Rotor Assembly – Round Tip Blades (Ref, no longer available. Superseded by C008-9 Tail Rotor Assembly, see Figure 64-1.)		
2	C029-2*	Blade Assembly – Round Tip (Ref, no longer available.)		
3	C137-1	Spacer	X	6
4	C137-2	Spacer	X	2
5	B330-16	Palnut	X	4
6	D210-5	Nut	X	4
7	NAS1149F0563P	Washer (or AN970-5, NAS1149F0532P, NAS1149D0532J, NAS1149D0563J, C141-20, or any combination as required for balance; [4] required for each blade)	X	4
8	NAS1149F0532P	Washer ([4] required with item 35)	X	6
9	NAS6606-34	Bolt	X	2
10	C138-1	Bushing	X	2
11	D062-1	Hub Assembly (No longer available. Superseded by C008-9 Tail Rotor Assembly, see Figure 64-1.)	O	1
	D062-2	Tail Rotor Hub (life-limited component, see MM § 3.100)	O	1
12	NAS6605-31	Bolt ([4] required with item 35)	X	2
13	C031-1	Pitch Control Assembly (Ref, see Figure 65-7)		
14	NAS6604-16	Bolt	X	A/R
15	A214-3	Washer	X	4
16	A115-1	Spacer	X	8
17	B345-4	Link (ship S/N 0160 and higher)	X	2
18	NAS1149F0432P	Washer	X	4
19	D210-4	Nut	X	5
20	B330-13	Palnut	X	5
21	NAS6604-17 to -22	Bolt (increase length to add washer weights)	X	2
22	NAS6606-53	Bolt	X	1
23	NAS1149F0632P	Washer	X	2
24	D210-6	Nut	X	1
25	B330-19	Palnut	X	1
26	NAS1149F0463P	Washer (or A141-14, NAS1149F0432P, NAS1149D0432J, NAS1149D0463J, or A214-3 as required for balance)	X	A/R

NOTES * Ship S/N 10001 and subsequent.

Continues

FIGURE AND INDEX NUMBER	PART NUMBER	DESCRIPTION	PARTS AVAIL	QTY PER ASSY
TAIL ROTOR ASSEMBLY (Cont'd)				
64-5-27	C119-2	Bumper (black)	X	1
28	A141-14	Washer	X	1
29	MS24694-S4	Screw	X	4
30	C610-1	Tip Cover	X	2
31	NAS602-12	Screw (or NAS602-14P, as required for balance)	X	4
32	NAS1149FN816P	Washer (or NAS1149FN832P, as required for balance)	X	A/R
33	C134-1	Balance Weight (0.032 in. thick steel, as required for balance)	X	A/R
34	B361-2*	Bearing	X	2
* * *				
35	C008-2	Tail Rotor Assembly – Square Tip Blades (Ref, no longer available. Superseded by C008-9 Tail Rotor Assembly; see Figure 64-1.)		
36	C029-1	Blade Assembly – Square Tip (Ref, no longer available.)		

NOTES * MT556-11 tools required to install bearing. See Figure 99-11.

Intentionally Blank

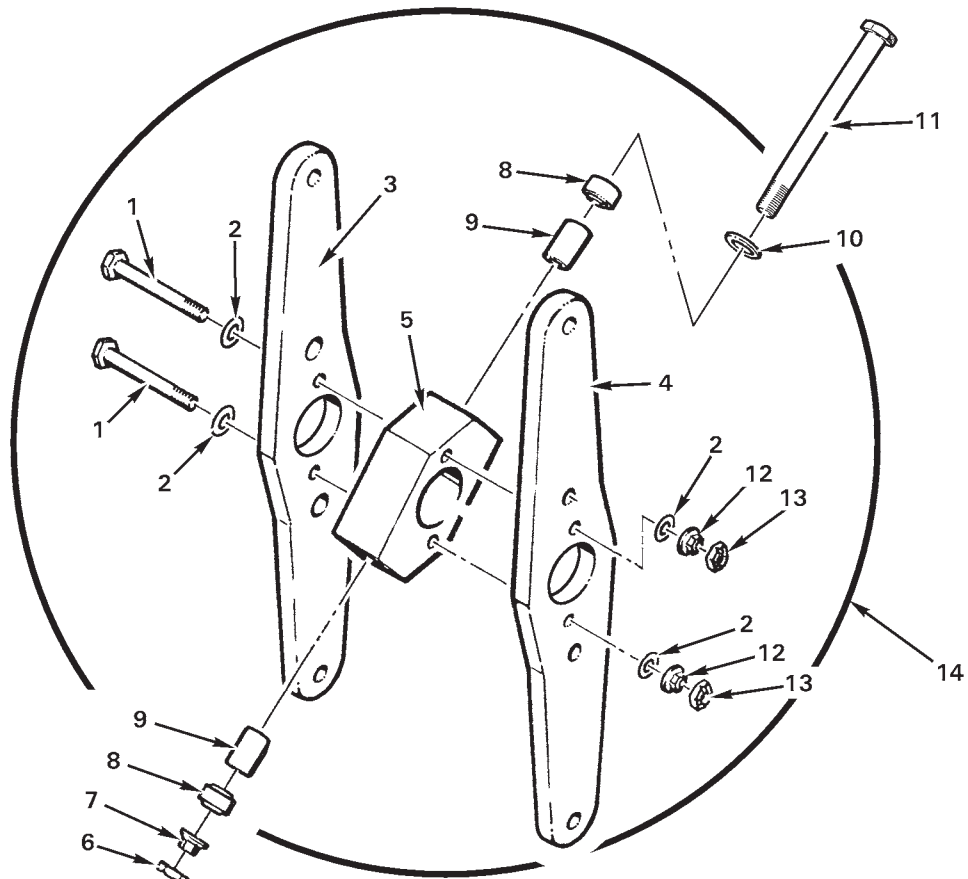
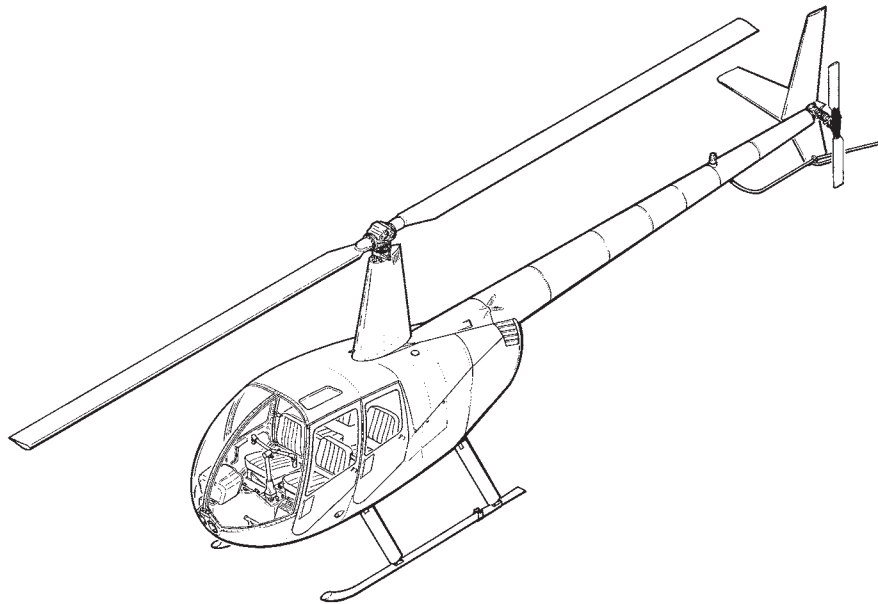

FIGURE AND INDEX NUMBER	PART NUMBER	DESCRIPTION	PARTS AVAIL	QTY PER ASSY
HUB ASSEMBLY				
64-9-1	NAS6604-31	Bolt	X	2
2	NAS1149F0432P	Washer	X	4
3	C129-2*	Hub Plate – Inboard	O	1
4	C129-1*	Hub Plate – Outboard	O	1
5	C128-1*	Hub	O	1
6	B330-19	Palnut	X	1
7	D210-6	Nut	X	1
8	D115-1	Bearing	X	2
9	C130-1	Spacer	X	2
10	C127-1	Washer (ship S/N 0220 and higher)	X	1
11	NAS6606-54**	Bolt	X	1
12	D210-4	Nut	X	2
13	B330-13	Palnut	X	2
14	C030-1*	Hub Assembly (Ref; includes items 1 thru 13)		

NOTES * Ref, no longer available. Superseded by C008-9 Tail Rotor Assembly, see Figure 64-1.
 ** For ship S/N 0001 thru 0219, replace NAS6606-53 bolt with NAS6606-54 bolt and C127-1 washer (item 10).

Intentionally Blank

CHAPTER 65

TAIL ROTOR DRIVE SYSTEM

<i>Figure</i>	<i>Title</i>	<i>Page</i>
65-1	Tail Rotor Drive Shaft Installation	65.0
65-5	Damper Assembly	65.4
65-7	Tail Rotor Gearbox Installation	65.6
65-11	Tail Rotor Gearbox Seals	65.10

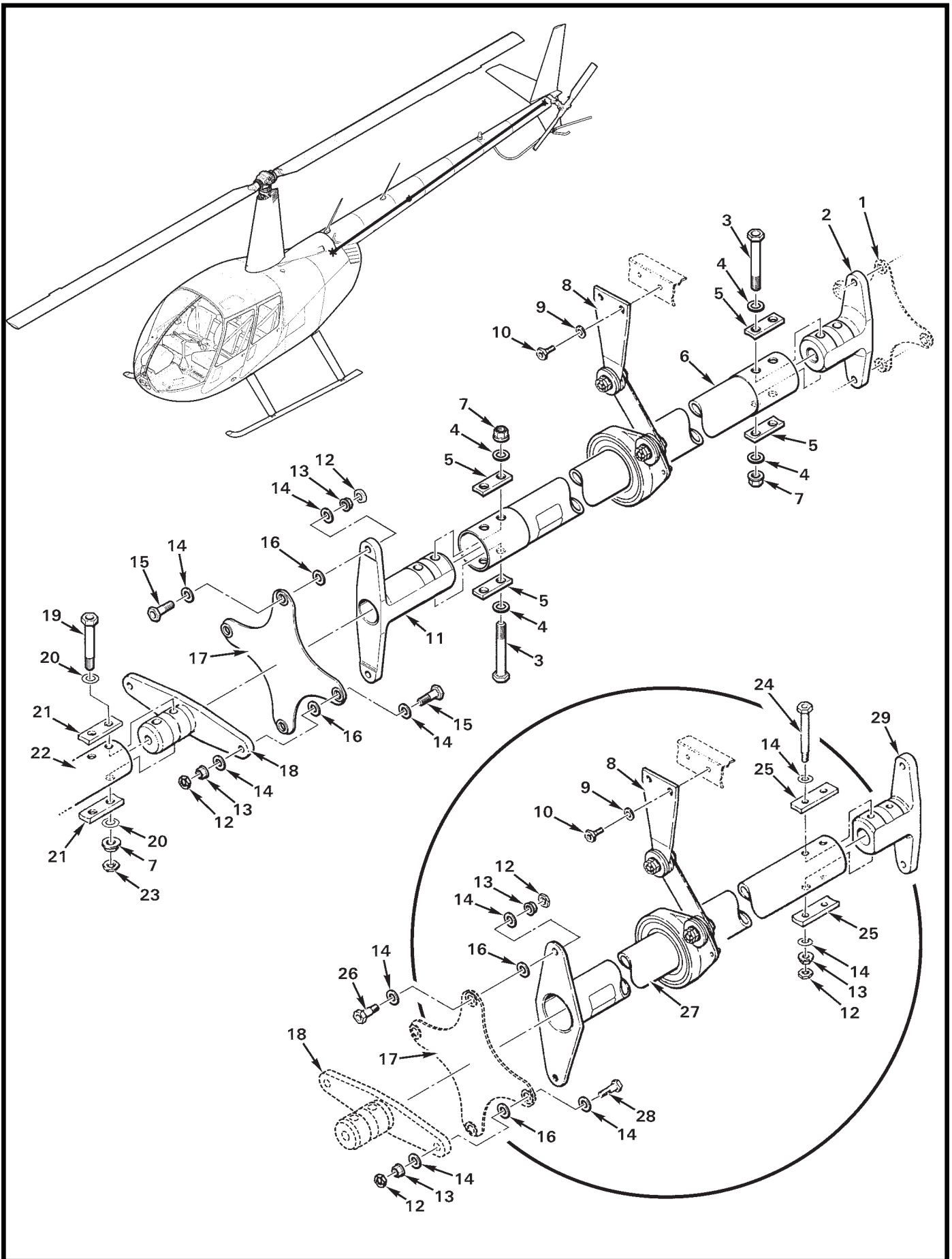

FIGURE AND INDEX NUMBER	PART NUMBER	DESCRIPTION	PARTS AVAIL	QTY PER ASSY
TAIL ROTOR DRIVE SHAFT INSTALLATION				
65-1-1	C947-3	Flex Plate (Ref, see Figure 65-7)		
2	D195-2	Yoke	X	1
3	NAS6605-28	Bolt	X	4
4	NAS1149F0532P	Washer	X	8
5	C191-7	Block	X	4
6	D224-2*	Tail Rotor Drive Shaft Assembly (Supersedes D224-1; includes D196-1 drive shaft, items 2 thru 5, and 7 thru 11.) . . .	X	1
	D196-1	Tail Rotor Drive Shaft (Ref; aluminum shaft)	O	1
7	MS21042L5	Nut	X	6
8	C041-1	Damper Assembly (see Figure 65-5)	X	1
9	NAS1149F0363P	Washer	X	2
10	NAS6603-3	Bolt	X	2
11	D195-1	Yoke	X	1
12	B330-13	Palnut ([6] required with item 27)	X	4
13	D210-4	Nut	X	4
14	NAS1149F0432P	Washer ([12] required with item 27)	X	8
15	NAS6604-6	Bolt (or NAS6604-7)	X	4
16	NAS1149F0432P	Washer (or NAS1149F0463P)	X	8
17	A947-2	Flex Plate	X	1
18	C195-1	Yoke (length = 2.100 in.)	X	1
	C195-2	Yoke (length = 2.220 in.)	X	1
	C195-3	Yoke (length = 2.340 in.)	X	1
	C195-4	Yoke (length = 2.460 in.)	X	1
19	NAS6605-24	Bolt	X	2
20	NAS1149F0532P	Washer	X	4
21	C191-6	Block	X	2
22	C166-4	Shaft – Clutch (Ref, see Figure 63-15)		
23	B330-16	Palnut	X	2
24	NAS6604-28	Bolt	X	2
25	C191-2	Block	X	2
26	NAS6604-4	Bolt (or NAS6604-5)	X	2

NOTES * See Figure 99-23 for shipping crate.

Continues

FIGURE AND INDEX NUMBER	PART NUMBER	DESCRIPTION	PARTS AVAIL	QTY PER ASSY
TAIL ROTOR DRIVE SHAFT INSTALLATION (Cont'd)				
65-1-27	D224-1	Tail Rotor Drive Shaft Assembly – Steel Shaft (Ref, no longer available)		
	C196-1	Tail Rotor Drive Shaft (Ref; steel, no longer available)		
28	NAS6604-5	Bolt (or NAS6604-6)	X	2
29	C195-5	Yoke (used with item 27)	X	1
NOTES				

Intentionally Blank

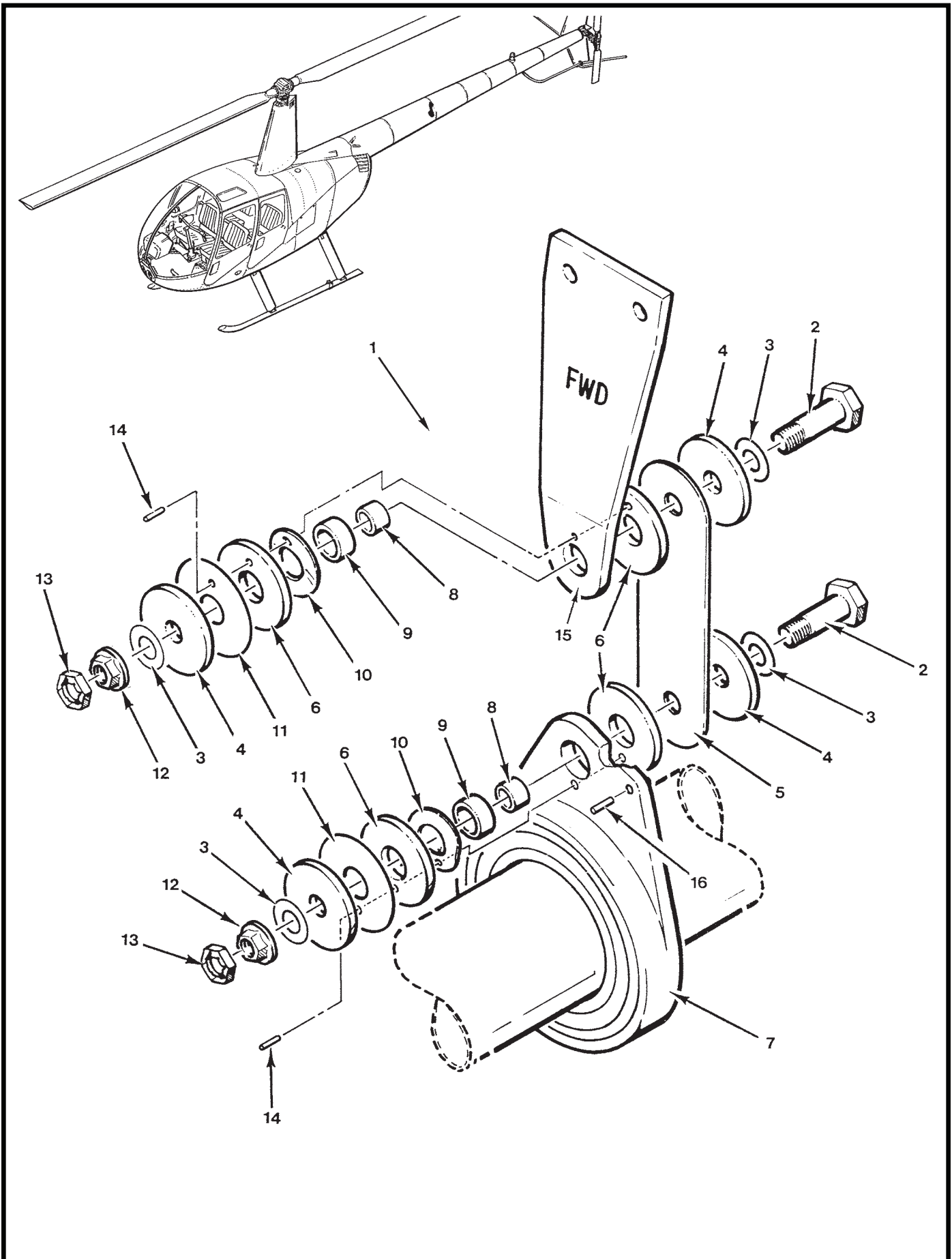

FIGURE AND INDEX NUMBER	PART NUMBER	DESCRIPTION	PARTS AVAIL	QTY PER ASSY
DAMPER ASSEMBLY				
65-5-1	C041-1	Damper Assembly (Incl items 2 thru 16)	X	1
2	NAS6604-6	Bolt	X	2
3	NAS1149D0416J	Washer	X	4
4	A141-37	Washer	X	4
5	C041-3	Link	X	1
6	C041-5	Washer	X	4
7	C041-11	Bearing Assembly (includes bearing and housing)	X	1
	C172-1	Housing	O	1
8	A105-12	Journal	X	2
9	05DU04	Bushing	X	2
10	C041-6	Spring Washer	X	2
11	A141-36	Washer	X	2
12	D210-4	Nut	X	2
13	B330-13	Palnut	X	2
14	A041-10	Dowel Pin	X	2
15	C041-8	Arm	X	1
16	MS16562-11	Roll Pin	X	1

NOTES

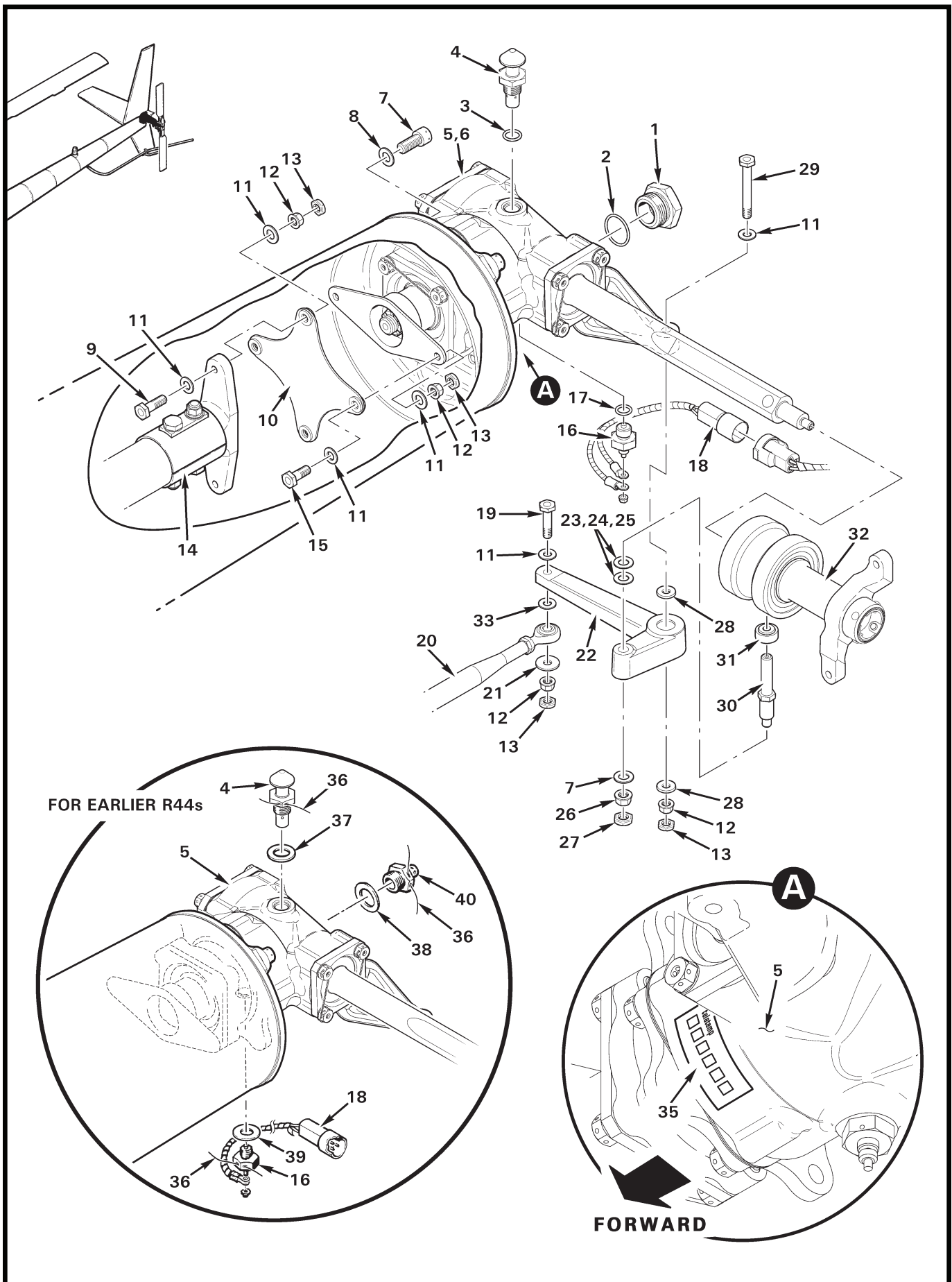

FIGURE AND INDEX NUMBER	PART NUMBER	DESCRIPTION	PARTS AVAIL	QTY PER ASSY
TAIL ROTOR GEARBOX INSTALLATION				
65-7-1	B563-4	Sight Gage (flat, UV filter)	X	1
2	A215-020	O-Ring	X	1
3	MS28778-5	Packing	X	1
4	A610-1	Filler – Vent Plug	X	1
5	C021-1	Gearbox Assembly – Tail Rotor (Includes items 1 thru 4, 16 thru 18, 34, and 35. See also Figure 65-11.)	X	1
	C021-1R	C021-1 Gearbox Assembly – Tail Rotor (overhaul exchange)	X	1
6	A257-22*	Oil – Gear (1 gallon)	X	A/R
	A257-22QT*	Oil – Gear (1 quart)	X	A/R
	A257-2*	Oil – Gear (1 gallon)	X	A/R
	A257-2LT*	Oil – Gear (1 liter)	X	A/R
7	NAS1352-5-12P	Cap Screw (for tailcone S/N 3562 and subsequent)	X	4
	NAS1352-5H12P	Cap Screw (requires 0.032-in. dia. safety wire [item 36])	X	4
8	NAS1149F0532P	Washer	X	5
9	NAS6604-7	Bolt	X	2
10	C947-3	Flex Plate	X	1
11	NAS1149F0432P	Washer	X	10
12	D210-4	Nut	X	6
13	B330-13	Palnut	X	6
14	D224	Tail Rotor Drive Shaft Assembly (Ref, see also Figure 65-1)		
15	NAS6604-4	Bolt	X	2
16	B566-2	Chip Detector	X	1
17	MS28778-4	Packing	X	1
18	C049-1	Harness Assembly (chip detector)	X	1
19	NAS6604-10	Bolt (or NAS6604-11)	X	1
20	C121-17	Push-Pull Tube Assembly	X	1
21	A214-3	Washer	X	1
22	A120-3	Bellcrank Assembly	X	1
23	C117-34	Shim – Washer (thickness = 0.016 in.)	X	A/R
24	C117-35	Shim – Washer (thickness = 0.020 in.)	X	A/R
25	C117-36	Shim – Washer (thickness = 0.026 in.)	X	A/R
26	D210-5	Nut	X	1

NOTES * Use correct gearbox oil per R44 Service Letter SL-73.

Continues

FIGURE AND INDEX NUMBER	PART NUMBER	DESCRIPTION	PARTS AVAIL	QTY PER ASSY
TAIL ROTOR GEARBOX INSTALLATION (Cont'd)				
65-7-27	B330-16	Palnut	X	1
28	MS20002-4	Washer	X	2
29	NAS6604-25	Bolt	X	1
30	C125-1	Stud	O	1
31	A104-4	Bearing	O	1
32	C031-1	Pitch Control Assembly (Incl items 30 and 31)	X	1
	C031-1R	C031-1 Pitch Control Assembly (overhaul exchange)	O	1
33	NAS1149F0432P	Washer (or NAS1149F0463P to maintain clearance)	X	A/R
34	C545-1	Gear Set (not shown)	O	1
35	F110-2	Telatemp (Temperature Recorder, 140°–190°F)	X	1
	110-2	Telatemp (Temperature Recorder, 140°–190°F; earlier R44s)	O	1
36	MS20995C32	0.032-in. dia. Safety Wire	X	A/R
37	MS35769-9	Gasket	X	1
38	MS35769-11	Gasket	X	1
39	MS35769-8	Gasket	X	1
40	B563-1	Sight Gage (bubble).	X	1

NOTES

Intentionally Blank

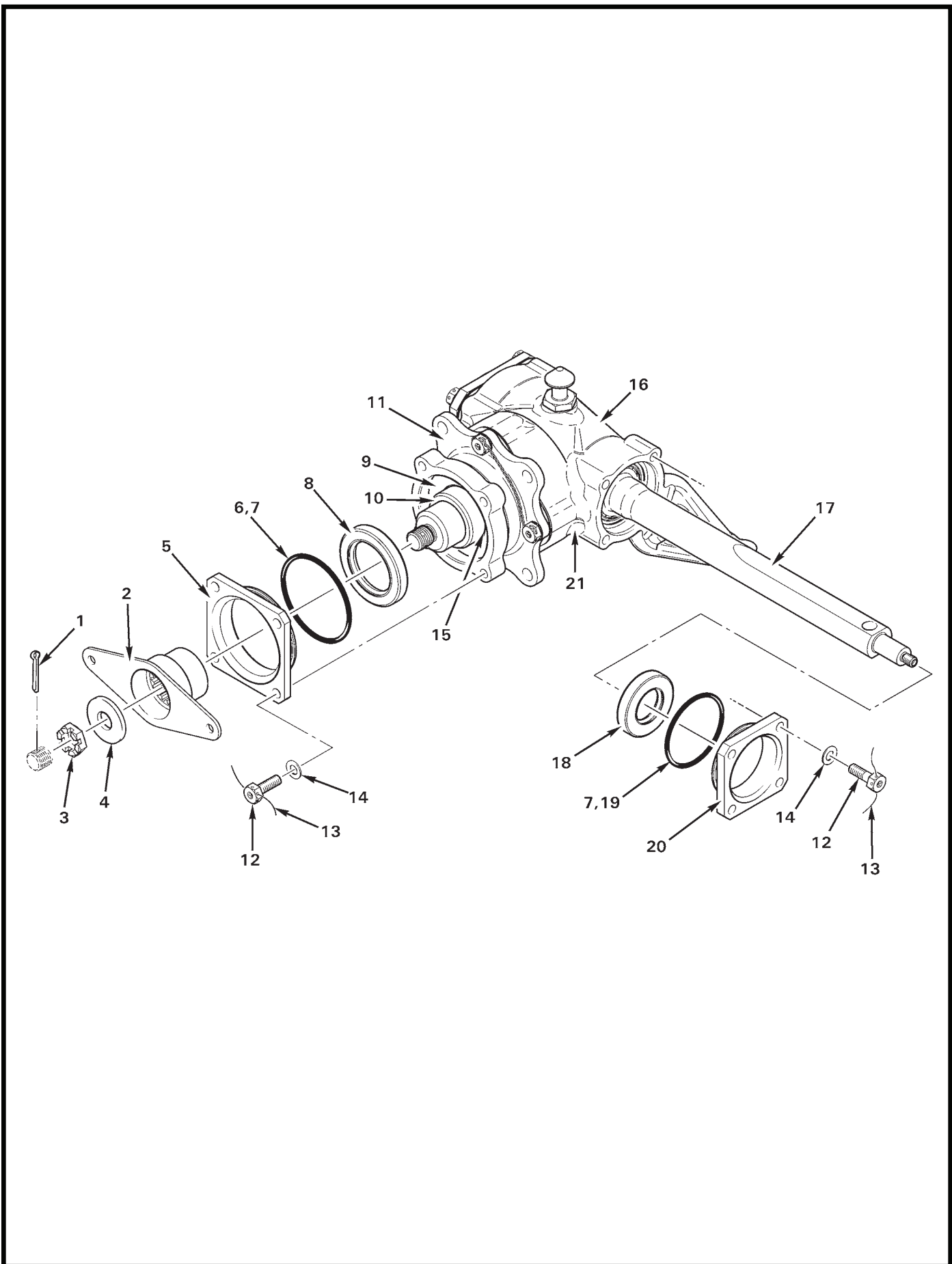

FIGURE AND INDEX NUMBER	PART NUMBER	DESCRIPTION	PARTS AVAIL	QTY PER ASSY
TAIL ROTOR GEARBOX SEALS				
65-11-1	MS24665-210	Cotter Pin	X	1
2	C116-1	Yoke	X	1
3	AN320-8	Nut	X	1
4	A141-10	Washer	X	1
5	C112-1	Cap	X	1
6	C215-140	O-Ring (install using item 7)	X	1
7	A257-2	Gear Oil	X	A/R
8	A966-3	Seal	X	1
9	C141-2	Washer (Ref, between cap and input cartridge)	O	1
10	C266-2	Spacer	X	1
11	C110-1	Input Cartridge (Ref)	O	1
12	MS20074-04-06	Bolt	X	8
13	MS20995C32	0.032 in. dia. Safety Wire	X	A/R
14	NAS1149F0432P	Washer	X	8
15	A215-024	O-Ring (install using item 7)	X	1
16	C109-2	Housing (Ref)	O	1
17	C107-1	Shaft - Output (Ref)	O	1
18	C966-2	Seal	X	1
19	C215-133	O-Ring (install using item 7)	X	1
20	C112-2	Cap	X	1
21	C021-1	Tail Rotor Gearbox Assembly (Ref; Incl items 1 thru 20)		

NOTES

Intentionally Blank

CHAPTER 67
FLIGHT CONTROLS

<i>Figure</i>	<i>Title</i>	<i>Page</i>
67-1	Cyclic Control System - Electric Trim	67.0
67-7	Cyclic Stick Assembly - Electric Trim	67.6
67-9	Forward Cyclic Installation	67.8
67-11	Cyclic Grip Assembly	67.10
67-15B	Cyclic Grip Assembly	67.15A
67-17	Cyclic Friction Assembly	67.16
67-21	Collective Stick Assembly	67.20
67-25	Collective Spring Assembly - Electric Trim	67.24
67-27	Main Rotor Controls	67.26
67-31	Main Rotor Controls	67.30
67-35	Main Rotor Controls	67.34
67-39	Torque Tube Installation	67.38
67-41	Aft Support Assembly	67.40
67-45	Aft Support Assembly	67.44
67-49	Push-Pull Tube Assemblies	67.48
67-51	Push-Pull Tube Guide Installation	67.50
67-53	Jackshaft Installation	67.52
67-57	Jackshaft Support Weldment Installation	67.56
67-59	Jackshaft Installation	67.58
67-61	Swashplate Installation	67.60
67-65	Swashplate Installation	67.64
67-69	Swashplate Installation	67.68

CHAPTER 67

FLIGHT CONTROLS (Cont'd)

<i>Figure</i>	<i>Title</i>	<i>Page</i>
67-73	Swashplate Ball Installation	67.72
67-75	Swashplate Ball Installation	67.74
67-77	Tail Rotor Controls - Pedals Installation	67.76
67-81	Tail Rotor Controls - Pedals Installation	67.80
67-85	Tail Rotor Controls - C317 Bellcrank	67.84
67-89	Tail Rotor Controls - C316 Bellcrank	67.88
67-91	Tail Rotor Controls - C331 Bellcrank	67.90

Intentionally Blank

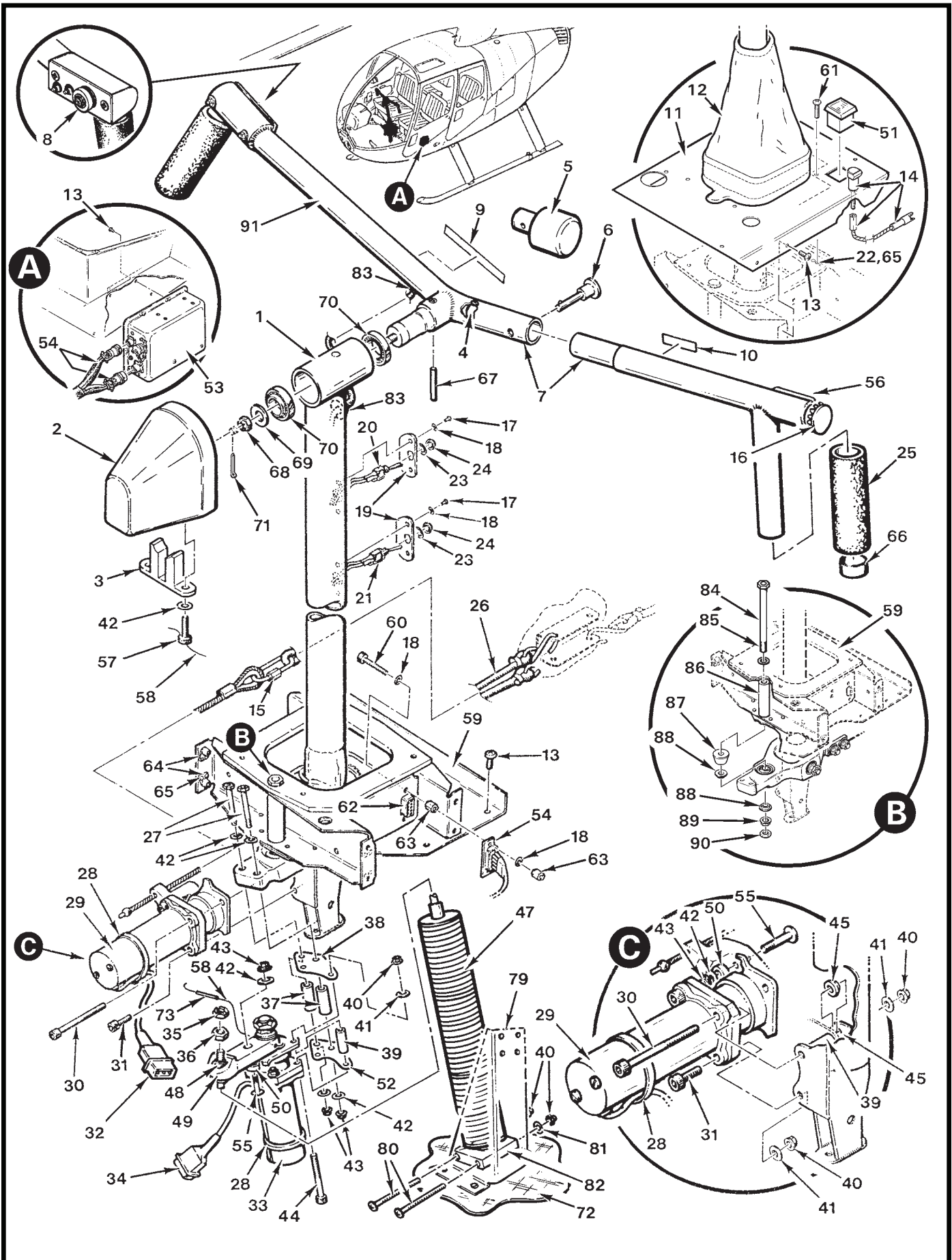

FIGURE AND INDEX NUMBER	PART NUMBER	DESCRIPTION	PARTS AVAIL	QTY PER ASSY
		CYCLIC CONTROL SYSTEM - ELECTRIC TRIM*		
67-1-1	C069-3*	Cyclic Control Assembly (Ref; includes items 7, 11, 12, 14, 17, 18 [2], 19 thru 21, 27, 28 [4], 29 [C055-10], 33 [C055-9], 37 [2], 46, 59 thru 63, 68 thru 71, 78, and 84 thru 90) . . .	X	1
2	C683-4**	Damper (Ref)		
3	C683-5	Clamp	X	1
4	A776-1	Mount - Intercom Plug (Ref, see Figure 97-15)	X	1
5	C683-6	Damper (install when co-pilot grip assembly is removed)	X	1
6	B232-1	Handle Pin	X	1
7	C058-1*	Grip Assembly - Pilot/Co-Pilot (Incl items 4, 6, 9, 10, 16, 25, 66, 67, and 83; see also Figure 97-15)	X	1
8	T4-0032**	Switch - Trim (see Figure 97-15, Ref)		
9	A654-83	Decal - "Low-G Pushovers Prohibited"	X	1
10	A654-43	Decal - "Solo From Right Seat Only"	X	1
11	C444-1	Cover Assembly (standard carb heat R44s)	X	1
	C444-3	Cover Assembly (R44s with carb heat assist; not shown)	X	1
	C444-5	Cover Assembly (R44s with carb heat assist and HSI installed; not shown)	X	1
12	A677-4	Boot	X	1
13	MS27039C0806	Screw	X	18
14	B195-6	Post Light	X	1
	B196-1	Lamp (14-volt)	X	1
	B196-21	Lamp (28-volt)	X	1
15	3711T21	Connector	X	1
16	SS51334	Plug	X	1
17	MS35206-212	Screw (use B270-10 adhesive on threads)	X	4
18	MS35333-36	Washer	X	8
19	B306-5	Mount - Trim (Upper; use only with TT13D2T switch. Replaces B306-2 mount.)	X	1
	B306-4	Mount - Landing Light (Lower; use only with TT13D2T switch. Replaces B306-1 mount.)	X	1
20	C049-12	Switch Assembly - Trim (Includes TT13D2T04 switch, wires, heat shrink, item 19 [B306-5], 23, and 24.)	X	1
	TT13D2T04	Switch (Use only with B306-4 [or -5] mount; include lockwasher)	X	1
	TT13D-7T-1/4**	Switch - Trim (Ref; no longer available. To replace, order C049-12 Switch Assembly.)		

NOTES * Ship S/N 0001 thru 0467. For ship S/N 0468 and subsequent, see Figure 67-11.

** No longer available.

Continues

FIGURE AND INDEX NUMBER	PART NUMBER	DESCRIPTION	PARTS AVAIL	QTY PER ASSY
		CYCLIC CONTROL SYSTEM - ELECTRIC TRIM (Cont'd)		
67-1-21	C049-9	Switch Assembly - Landing Light (Includes TT13D2T04 switch, wires, heat shrink, item 19 [B306-4], 23, and 24.)	X	1
	TT13D2T04	Switch (Use only with B306-4 [or -5] mount; incl lockwasher) . .	X	1
	TT13D-9T-1/4	Switch - Landing Light (Ref; no longer available. To replace, order B049-9 switch assembly.)		
22	MS21069L08	Nutplate (install using item 65)	X	4
23	—	Lockwasher	O	1
24	465701264	Dress Nut	X	1
25	A601-2	Grip (install using item 78)	X	2
26	C918-1	Elastic Cord Assembly - Aft (25 lb)	X	1
	C918-2	Elastic Cord Assembly - Aft (30 lb)	X	1
	C918-3	Elastic Cord Assembly - Aft (35 lb)	X	1
	C918-4	Elastic Cord Assembly - Aft (40 lb)	X	1
	C918-6	Elastic Cord Assembly - Aft (50 lb)	X	1
	C918-7	Elastic Cord Assembly - Aft (55 lb)	X	1
27	NAS6603-26	Bolt	X	2
28	MS3367-5-9	Ty-Rap	X	2
29	C055-6*	Cyclic Trim Assembly - Longitudinal (Ref)		
	C055-10**	Cyclic Trim Assembly - Longitudinal (Incl items 28, 30, 31, 32, 39 [1], 40, 41, 42 [1], 43 [1], 45, 50, and 55)	X	1
	C055-10R	C055-10 Cyclic Trim Assembly - Longitudinal (overhaul exchange)	X	1
30	NAS1352-08-32P	Screw	X	1
31	NAS1352-08-12P	Screw	X	1
32	B263-34	Housing	X	1
	B263-1	Pin	X	3
33	C055-2*	Cyclic Trim Assembly - Lateral (Ref)		
	C055-9**	Cyclic Trim Assembly - Lateral (Incl items 28, 34, 38, 39 [2], 40, 41, 44, 47, 52, 72, and 73)	O	1
	C055-9R	C055-9 Cyclic Trim Assembly - Lateral (overhaul exchange) . .	X	1
	C055-8*	Gearmotor Assembly - Lateral (Ref)		
	C055-11**	Gearmotor Assembly - Lateral (Incl items 28, 34, 38, 39 [2], 40, 41 [1], 42 [1], 43, 44, 48 thru 50, and 52)	X	1
	C005-11R	C055-11 Gearmotor Assembly - Lateral (overhaul exchange) . .	X	1

NOTES * Ship S/N 0001 thru 0190. Parts no longer available.
 ** Ship S/N 0191 and subsequent. Use only with D140-2 trim controller assembly.

Continues

FIGURE AND INDEX NUMBER	PART NUMBER	DESCRIPTION	PARTS AVAIL	QTY PER ASSY
CYCLIC CONTROL SYSTEM – ELECTRIC TRIM (Cont'd)				
67-1-34	B263-14	Housing	X	1
	B263-1	Pin	X	3
35	B330-13	Palnut	X	1
36	AN316-4R	Nut	X	1
37	C130-18	Spacer (Ref, no longer available)		
38	C582-3	Plate	X	1
39	C130-11	Spacer (Ref, no longer available)		
40	MS21042L08	Nut	X	4
41	NAS620-8L	Washer	X	4
42	NAS1149F0332P	Washer	X	8
43	MS21042L3	Nut	X	4
44	NAS1352-08-28P	Screw	X	2
45	C130-20	Spacer (Ref, no longer available)		
46	C048-1	Cyclic Friction Assembly (not shown; see Figure 67-17)		
47	C056-1	Spring Assembly – Lateral Cyclic Trim (Incl items 35, 36, 42 [2], 43, 48 thru 50, 55, and 82)	X	1
	C056-1R	Spring Assembly – Lateral Cyclic Trim (overhaul exchange)	X	1
48	B303-2	Bearing	O	1
49	C581-1	Arm	O	1
50	C130-13	Spacer (Ref, no longer available)		
51	FP-161	Plug	X	1
52	C582-1	Plate (Ref, no longer available)		
53	D140-1*	Trim Controller Assembly	O	1
	D140-2**	Trim Controller Assembly	O	1
54	D161-1	Harness Assembly (Includes plugs [shown], connectors, pin, sockets, lacing, etc. as an assembled unit. Ref, no longer available.)		
55	MS27039C1-15	Screw	X	1
56	—	Intercom and Transmit Switches (Ref, see Figure 97-15)	X	1
57	NAS1352-3H14	Screw	X	2
58	MS20995C32	0.032 in. dia. Safety Wire	X	A/R
59	C338-4	Cyclic Box (Ref, includes item 22)		

NOTES * Ship S/N 0001 thru 0190. Parts no longer available.
 ** Ship S/N 0191 thru 0679 without optional hydraulics. Parts no longer available.

Continues

FIGURE AND INDEX NUMBER	PART NUMBER	DESCRIPTION	PARTS AVAIL	QTY PER ASSY
		CYCLIC CONTROL SYSTEM – ELECTRIC TRIM (Cont'd)		
67-1-60	NAS1352C04-10	Screw (Ref, no longer available)		
61	MS27039C0808	Screw (around boot)	X	4
62	B269-1	Connector (Ref)		
63	2052-440-SS-0	Stand Off (Ref, no longer available)	O	2
64	MS21086L08	Nutplate	X	8
65	MS20426AD3	Rivet	X	24
66	A959-6	End Cap	X	2
67	B350-1	Roll Pin	X	1
68	MS17825-4	Nut	X	1
69	A141-14	Washer	X	1
70	A647-2	Bearing	X	2
71	MS24665-69	Cotter Pin	X	1
72	C272-1	Chin (Ref)		
73	MS16562-36	Roll Pin	X	1

74	KI-99	Cyclic Trim System Upgrade Kit (Ship S/N 0001 thru 0190, no longer available.)		
75	C055-10R	C055-10 Cyclic Trim Assembly – Longitudinal (overhaul exchange)	X	1
76	C055-11R	C055-11 Gearmotor Assembly – Lateral (overhaul exchange) . .	X	1
77	D140-2R	D140-2 Trim Controller Assembly (overhaul exchange)	O	1

78	B270-15	Adhesive (not shown)	X	A/R
79	C591-1	Brace (Ref)		
80	MS35206-253	Screw	X	2
81	NAS1149FN816P	Washer	X	2
82	C591-2	Block (Ref)		
83	MS35489-4	Grommet	X	1
84	NAS6605-56	Bolt	X	1
85	NAS1149F0532P	Washer	X	1
86	A130-6	Spacer	X	1
87	A339-1	Spacer	X	1

NOTES

Continues

FIGURE AND INDEX NUMBER	PART NUMBER	DESCRIPTION	PARTS AVAIL	QTY PER ASSY
CYCLIC CONTROL SYSTEM – ELECTRIC TRIM (Cont'd)				
67-1-88	A340-1	Spacer	X	2
89	D210-5	Nut	X	1
90	B330-16	Palnut	X	1
91	A756-6	Grip Assembly – Cyclic (RH, pilot. Ref; Ship S/N 0001 thru 0467.)		
NOTES				

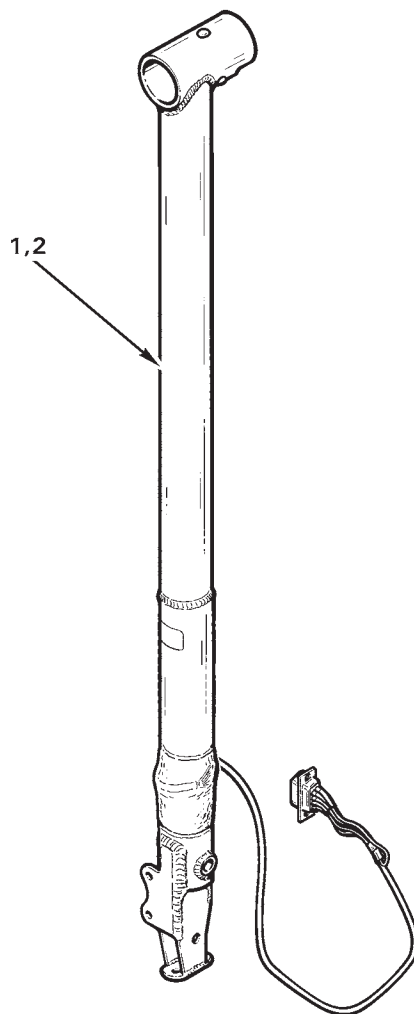

FIGURE AND INDEX NUMBER	PART NUMBER	DESCRIPTION	PARTS AVAIL	QTY PER ASSY
<p>67-7-1</p> <p>2</p>	<p>C318-1</p> <p>C320-1</p>	<p style="text-align: center;">CYCLIC STICK ASSEMBLY – ELECTRIC TRIM*</p> <p>Cyclic Stick Assembly with Strain Gages (Ref; ship S/N 0001 thru 0652 with manual controls. No longer available.)</p> <p>Stick Assembly (Ref, welded stick assembly only.)</p>	<p>0</p>	<p>1</p>
<p>NOTES * Manual controls.</p>				

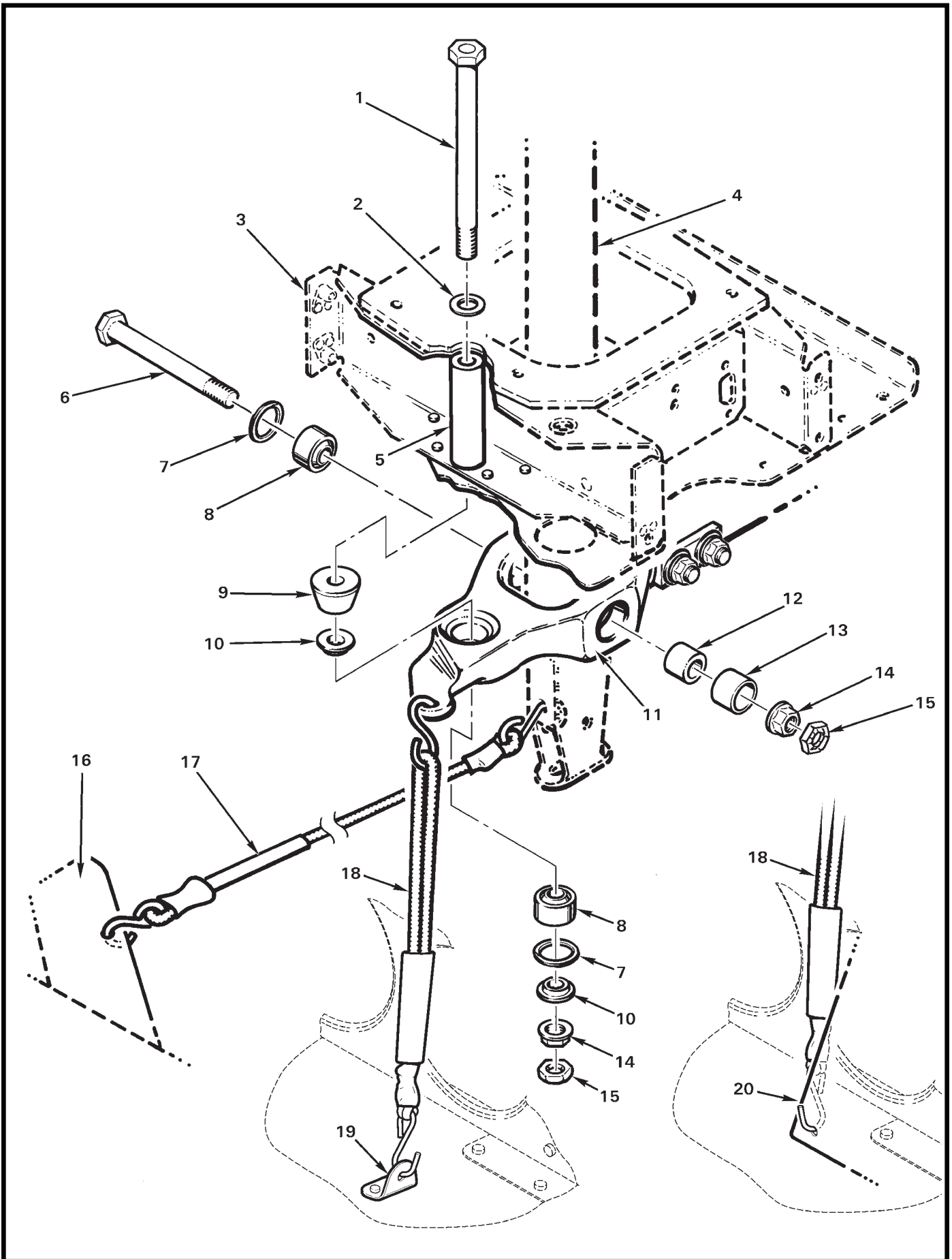

FIGURE AND INDEX NUMBER	PART NUMBER	DESCRIPTION	PARTS AVAIL	QTY PER ASSY
FORWARD CYCLIC INSTALLATION*				
67-9-1	NAS6605-56	Bolt	X	1
2	NAS1149F0532P	Washer	X	1
3	C338-4	Cyclic Box (Ref)		
4	C069	Cyclic Control Assembly (Ref)		
5	A130-6	Spacer	X	1
6	NAS1305-35	Bolt	X	1
7	WH-68-S02	Ring	X	2
8	A103-5	Bearing (install using B270-11 adhesive)	X	2
9	A339-1	Spacer	X	1
10	A340-1	Spacer	X	2
11	C177-3	Pivot (Ref; see Figure 67-31 and Figure 67-27)		
12	C105-3	Journal	X	1
13	O8DU06	Bearing	X	1
14	D210-5	Nut	X	2
15	B330-16	Palnut	X	2
16	A697-4	Bracket	X	1
17	D918-1	Elastic Cord (longitudinal)	X	1
18	D918-2	Elastic Cord (lateral)	X	1
19	A748-3	Angle (Ref)		
20	C591-4	Brace (Ref, earlier R44s. Superseded by item 19.)		

NOTES * Hydraulic controls.

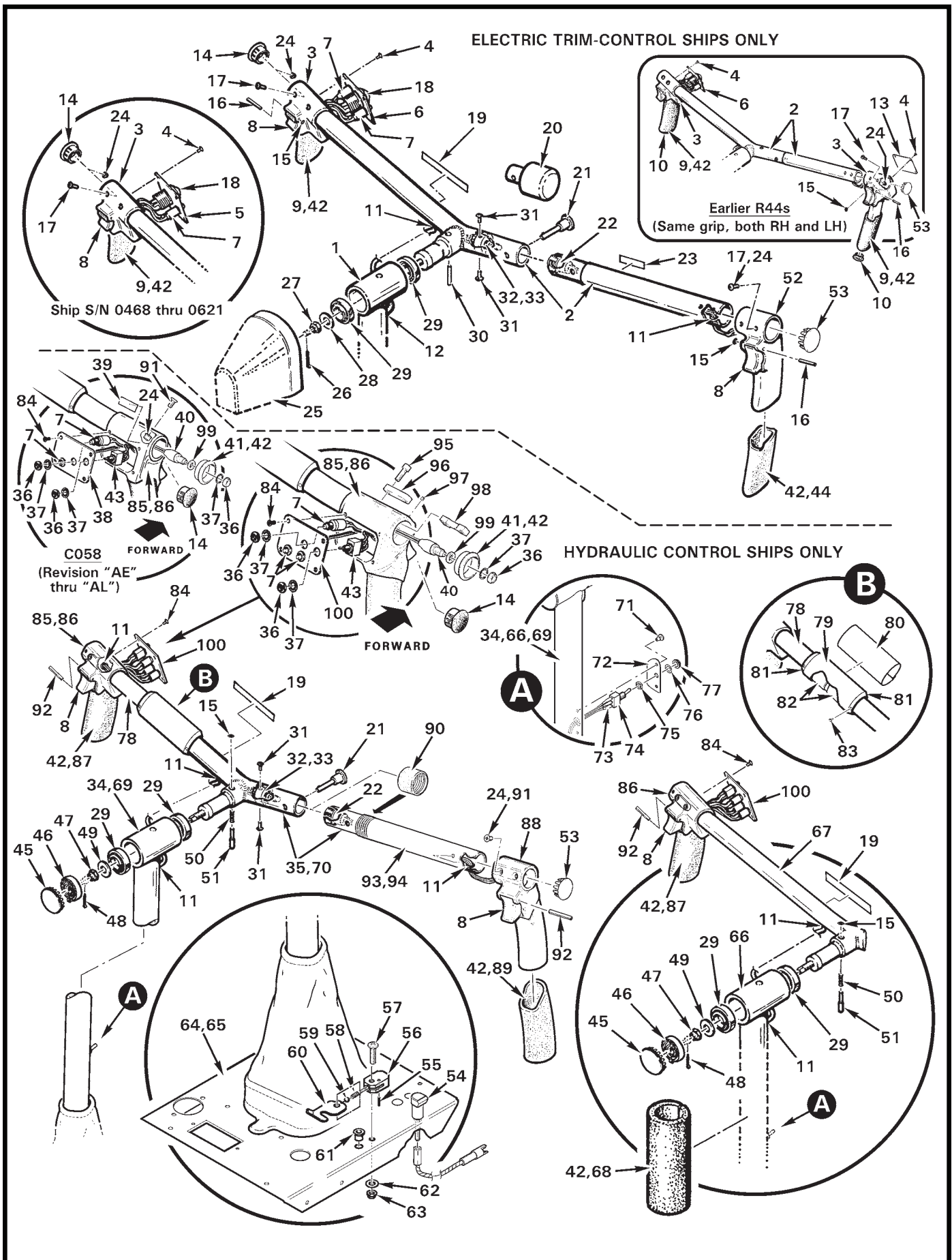

FIGURE AND INDEX NUMBER	PART NUMBER	DESCRIPTION	PARTS AVAIL	QTY PER ASSY
CYCLIC GRIP ASSEMBLY				
67-11-1	C069-3*	Cyclic Control Assembly (Includes items 11, 12, 14, 17, 18 [2], 19 thru 21, 27, 28 [4], 29 [C055-10], 33 [C055-9], 37 [2], 46, and 59 thru 63 from Figure 67-1. Includes items 2, and 26 thru 29 from Figure 67-11.)	X	1
2	C058-1*	Grip Assembly - Pilot/Co-Pilot (Ref)	X	1
3	D373-1**	Grip (Ref)	X	A/R
4	MS24693-S2	Screw	X	A/R
5	C214-2	Plate ("Freq, Trim". Use with [1] of item 7. Ship S/N 0468 thru 0621.)	X	1
6	C214-7	Plate ("Freq, Trim, Ch Sel". Use with [2] of item 7. Ship S/N 0622 thru 0662.)	X	1
7	B227-2	Switch Assembly ("flip-flop"; includes items 36 and 37)	X	A/R
8	U2-279	Trigger Switch	X	2
9	D373-3	Cover (install using item 42)	X	2
10	2663	Hole Plug (DP-625)	X	2
11	MS35489-4	Grommet	X	A/R
12	MS35489-6	Grommet	X	1
13	C214-1	Plate (plain)	X	1
14	2703	Hole Plug (DP-875)	X	A/R
15	MS16633-2012	Retaining Ring (or MS16633-1012)	X	A/R
16	D443-1**	Pin (Ref)		
17	MS27039C0806	Screw	X	A/R
18	T4-0032**	Switch - Trim (Ref)		
19	A654-83	Decal - "Low-G Pushovers Prohibited" (for earlier R44s)	X	1
20	C683-6	Counterweight (install when co-pilot grip assembly is removed)	X	1
21	B232-1	Handle Pin	X	1
	B815-1	Handle Pin - Oversize (0.197/0.195 in. dia. hole)	X	1
	B815-2	Handle Pin - Oversize (0.219/0.217 in. dia. hole)	X	1
22	TJT-120	Jack (Ref, see Figure 97-15)		
23	A654-43	Decal - "Solo From Right Seat Only" (for earlier R44s)	X	1
24	MS21042L08	Nut	X	A/R
25	C683-4	Damper (Ref, see Figure 67-1)		
26	MS24665-69	Cotter Pin	X	1

NOTES * Ship S/N 0468 thru 0662 with electric trim.

** No longer available.

Continues

FIGURE AND INDEX NUMBER	PART NUMBER	DESCRIPTION	PARTS AVAIL	QTY PER ASSY
CYCLIC GRIP ASSEMBLY (Cont'd)				
67-11-27	MS17825-4	Nut	X	1
28	A141-14	Washer	X	1
29	A647-2	Bearing	X	2
30	B350-1	Roll Pin	X	1
31	MS35206-241	Screw	X	2
32	A776-1	Mount (Ref, see Figure 97-15)	X	1
33	A781-1	Intercom Plug (Ref, see Figure 97-15)	X	1
34	C069-5*	Cyclic Control System (Hydraulic R44s, O-540 engine. Includes items 12, 17, 18, 21, 59, and 61 from Figure 67-1; items 29, 35, 45 thru 49, 54 thru 64, and 71 and 74 from Figure 67-11; items 1, 3 thru 5, 7, 15, 16, 25, 26, 32, and 34 from Figure 67-17; items 1 thru 3, and 5 thru 15 from Figure 67-9. Also includes NAS6604-9 bolt, NAS1149F0432P washer [2], MS21042L4 nut, and B330-13 palnut from Figure 67-31 or Figure 67-27.)	X	1
35	C058-7*	Grip Assembly - Pilot/Co-Pilot (Hydraulic R44s, O-540 engine. Includes items 7, 8, 11, 14, 21, 22, 24, 31 thru 33, 38, 42, 43, 44, 50 thru 53, 84, 85, and 87 thru 93.)	X	1
36	B227-4	Dress Nut	X	1
37	B227-3	Lockwasher	X	1
38	C214-10	Plate ("Freq, Ch Sel, Hyd")	X	1
	C214-11	Plate ("Com Freq, Nav Freq, Hyd")	X	1
	C214-12	Plate ("Audio Panel Xmit, Freq, Hyd")	X	1
39	D682-9**	Decal - "Start" (for earlier R44 IIs)	X	1
40	B227-2**	Switch (starter, includes items 37 and 38)	X	1
41	D443-2**	Mount (install using item 42)	X	1
42	B270-15	Adhesive	X	A/R
43	B300-3	Switch Assembly - Hydraulic (Incl items 36 and 37)	X	1
44	D688-3	Cover (install using item 42)	X	1
45	B209-4	End Cap	X	1
46	D684-1	Spring	X	1
47	MS17825-5	Nut	X	1
48	MS24665-69	Cotter Pin	X	1
49	A141-40	Washer	X	1
50	D774-6	Spring (alternate part no. C0180-018-0690S)	X	1

NOTES * Ship S/N 0663 and subsequent.
 ** Ship S/N 10001 and subsequent.

Continues

FIGURE AND INDEX NUMBER	PART NUMBER	DESCRIPTION	PARTS AVAIL	QTY PER ASSY
CYCLIC GRIP ASSEMBLY (Cont'd)				
67-11-51	A321-16	Pin	X	1
52	D688-1	Grip (Ref, no longer available)	X	1
53	B209-3	Plug	X	1
54	B195-6	Post Light Assembly - 14-volt (includes B196-1 lamp, wiring, and connector)	X	1
	B195-16	Post Light Assembly - 28-volt (includes B196-21 lamp, wiring, and connector)	X	1
55	MS16562-23	Spring Pin	X	1
56	D333-8	Block	X	1
57	MS27039C1-11	Screw	X	1
58	D774-3	Spring (alternate part no. C0180-020-0380S)	X	1
59	B208-1	Ball	X	1
60	D333-6	Catch	X	1
61	2010	Bushing	X	1
62	NAS1149F0332P	Washer	X	1
63	MS21042L3	Nut	X	1
64	C444-3	Cover (O-540 ships. C444-5 if HSI-equipped.)	X	1
65	C444-7	Cover (IO-540 ships. C444-9 if HSI-equipped. Not shown.)	X	1
66	C069-6*	Cyclic Control Assembly - Police (Hydraulic R44s; IO-540 engine. Includes items 12, 59 and 61 from Figure 67-1; items 29, 45 thru 49, 54, 63 and 65, 67, 68, 71 and 74 from Figure 67-11; items 1, 3 thru 5, 15, 16, 25, 26, 32, and 34 from Figure 67-17; items 1 thru 3, and 5 thru 15 from Figure 67-9. Also includes NAS6604-9 bolt, NAS1149F0432P washer [2], MS21042L4 nut, and B330-13 palnut from Figure 67-31 and Figure 67-27.)	X	1
67	C058-6*	Grip Assembly - Cyclic, Police (Hydraulic R44s; IO-540 engine. Includes items 7, 8, 11, 15, 24, 38, 40 thru 43, 50, and 86 thru 93.)	X	1
68	A601-3	Grip - Foam (install using item 42)	X	1
69	C069-7**	Cyclic Control Assembly (Hydraulic R44s, IO-540 engine. Includes items 12, 59, and 61 from Figure 67-1; items 29, 45 thru 49, 54, 65, 70, 71 and 74 from Figure 67-11; items 1, 3 thru 5, 15, 16, 25, 26, 32, and 34 from Figure 67-17; items 1 thru 3, and 5 thru 15 from Figure 67-9. Also includes NAS6604-9 bolt, NAS1149F0432P washer [2], MS21042L4 nut, and B330-13 palnut from Figure 67-31 and Figure 67-27.)	X	1

NOTES * Ship S/N 0663 and subsequent.
 ** Ship S/N 10001 and subsequent.

Continues

FIGURE AND INDEX NUMBER	PART NUMBER	DESCRIPTION	PARTS AVAIL	QTY PER ASSY
CYCLIC GRIP ASSEMBLY (Cont'd)				
67-11-70	C058-8*	Grip Assembly - Cyclic (Hydraulic R44s; IO-540 engine. Includes items 3, 4, 7, 8, 11, 15, 21, 22, 24, 31 thru 33, 38, 40 thru 43, 50 thru 53, 84, and 86 thru 93.)	X	1
71	SR-3035B	Rivet	X	2
72	B306-4	Mount	X	1
73	B158-1	Heat Shrink	X	A/R
74	C049-9	Switch Assembly - Landing Light (Incl items 72, 73, 77, TT13D2T04 switch, and wires, assembled)	X	1
	TT13D2T04	Switch (Incl items 75 and 76)	X	1
75	—	Hex Nut	O	1
76	—	Lockwasher	O	1
77	298D01A56	Dress Nut	X	1
78	A756-22	Grip Weldment	X	1
79	G725-2	Tube	X	1
80	C654-53	Decal (flight limitations, O-540)	X	1
	C654-54	Decal (flight limitations, IO-540)	X	1
81	G725-3	Collar	X	2
82	B175-12	Loop Tape	X	A/R
83	SR-2032B	Rivet	X	2
84	MS24G93-S1	Screw	X	4
85	D379-1	Grip (O-540 ships, not shown)	X	1
86	D379-3	Grip (IO-540 ships)	X	1
87	D379-2	Cover (install using item 42)	X	1
88	D690-1	Grip	X	1
89	D690-2	Cover (install using item 42)	X	1
90	B321-22	Collar	X	1
91	MS24694-S3	Screw	X	4
92	NAS1407N9L	Pin	X	2
93	A321-21	Tube	X	1
94	C058-9	Grip Assembly - Co-pilot (Incl items 8, 11, 21, 22, 24, 42, and 88 thru 93)	X	1

NOTES * Ship S/N 10001 and subsequent.

Intentionally Blank

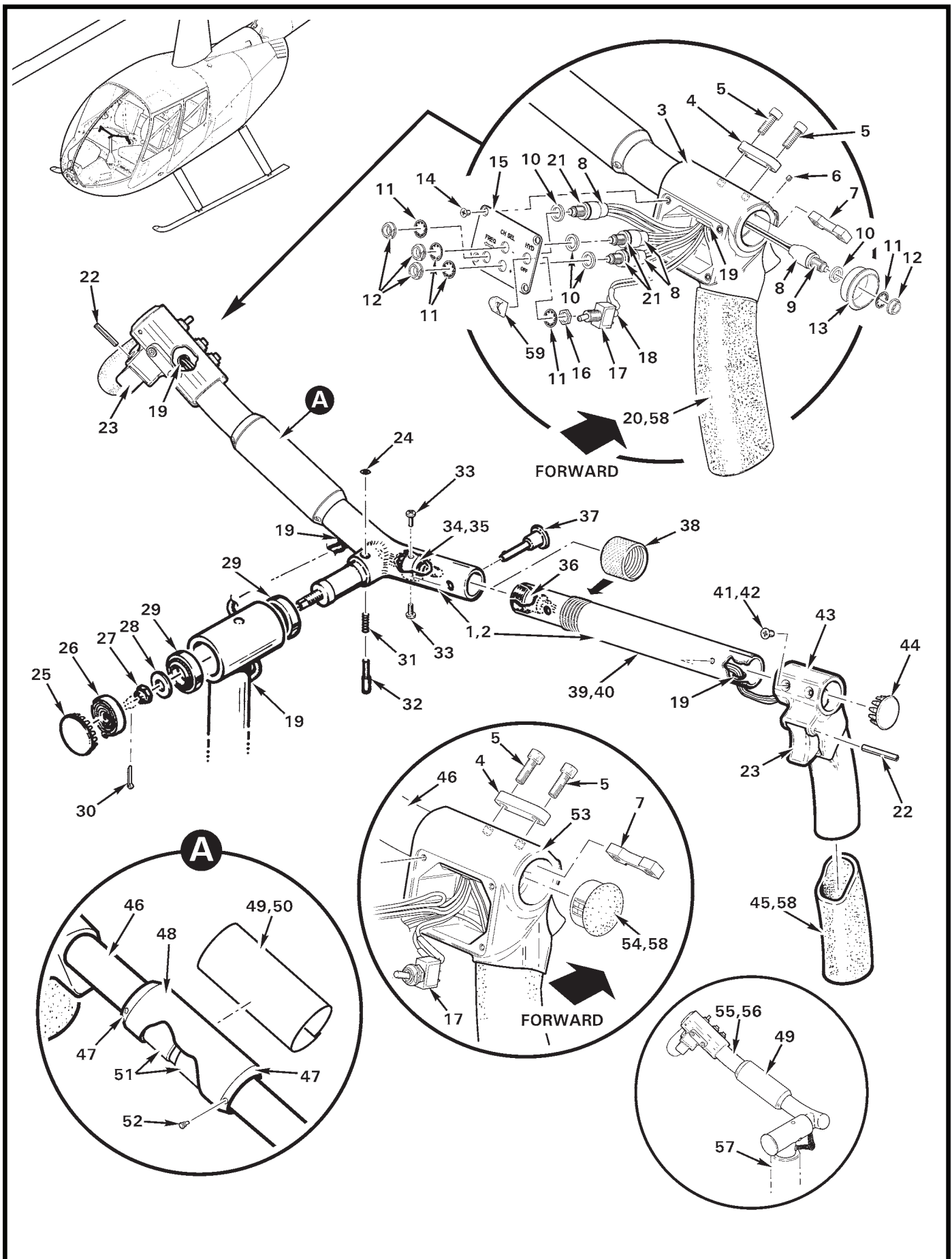

FIGURE AND INDEX NUMBER	PART NUMBER	DESCRIPTION	PARTS AVAIL	QTY PER ASSY
		CYCLIC GRIP ASSEMBLY*		
67-15B-1	C058-8	Grip Assembly – Cyclic (IO-540 engine. Includes items 3 thru 9, 13 thru 15, 17 thru 24, 31 thru 39, 41 thru 49, 51, 52, and 58.)	X	1
2	C058-7	Grip Assembly – Cyclic (O-540 engine. Includes items 4, 5, 6 thru 8, 14, 15, 17 thru 24, 31 thru 39, 41 thru 48, 50 thru 54, and 58.)	X	1
3	D379-3	Grip	X	1
4	D443-5	Bar	X	1
5	91251A194	Screw	X	2
6	28701L-94C-2	Set Screw	X	1
7	D443-3	Block Assembly	X	1
8	B158-6	Heat Shrink	X	A/R
9	B227-2	Switch Assembly (starter; includes items 10 thru 12)	X	1
10	94773A770	Washer	X	1
11	B227-3	Lockwasher	X	1
12	B227-4	Dress Nut	X	1
13	D443-2	Mount	X	1
14	MS24693-S1	Screw	X	4
15	C214-24	Plate (“Freq Xfer, – User Freq + , Hyd Off”)	X	1
16	—	Hex Nut	O	1
17	B300-3	Switch Assembly (“Hyd Off”; includes items 11, 12, and 16)	X	1
18	B158-2	Heat Shrink	X	A/R
19	MS35489-4	Grommet	X	4
20	D379-2	Cover (install using item 58)	X	1
21	B227-2	Switch Assembly (Incl items 10 thru 12)	X	3
22	NAS1407N9L14	Pin	X	2
23	U2-279	Trigger Switch	X	2
24	MS16633-2012	Retaining Ring	X	1
25	B209-4	Plug	X	1
26	D684-1	Spring	X	1
27	MS17825-5	Nut	X	1
28	A141-40	Washer	X	1
29	A647-2	Bearing	X	2
30	MS24665-69	Cotter Pin	X	1
31	D774-6	Spring	X	1
32	A321-16	Pin	X	1

NOTES * C058-6, -7, -8, and -9 grip assemblies revision “AO” and higher.

Continues

FIGURE AND INDEX NUMBER	PART NUMBER	DESCRIPTION	PARTS AVAIL	QTY PER ASSY
CYCLIC GRIP ASSEMBLY* (Cont'd)				
67-15B-33	MS35206-241	Screw	X	2
34	A776-1	Mount	X	1
35	A781-1	Plug	X	1
36	TJT-120	Jack	X	1
37	B232-1	Pin	X	1
38	A321-22	Collar	X	1
39	A321-21	Tube	X	1
40	C058-9	Grip Assembly (Incl items 18, 19, 22, 23, 36 thru 39, 41 thru 45, and 58.)	X	1
41	MS24694-S3	Screw	X	2
42	MS21042L08	Nut (not shown)	X	2
43	D690-1	Grip	X	1
44	B209-3	Plug	X	1
45	D690-2	Cover (install using item 58)	X	1
46	A756-24	Grip Weldment	X	1
47	G725-3	Collar	X	2
48	G725-2	Tube	X	1
49	C654-54	Decal (flight limitations, IO-540 engine)	X	1
50	C654-53	Decal (flight limitations, O-540 engine)	X	1
	C654-59**	Decal (flight limitations, O-540 engine; R44 Cadet)	X	1
51	B175-12	Loop Tape	X	A/R
52	SR-2032B	Rivet	X	4
53	D379-1	Grip	X	1
54	2703	Hole Plug (install using item 58)	X	1
55	C058-6	Grip Assembly – Cyclic (IO-540) engine; Police helicopter. Includes items 3 thru 9, 13 thru 15, 17 thru 24, 31, 32, 47 thru 49, 51, 52, 56, and 58.)	X	1
56	A756-20	Grip Weldment	X	1
57	A601-3	Grip (Ref)		
58	B270-15	Adhesive	X	A/R

NOTES * C058-6, -7, -8, and -9 grip assemblies revision "AO" and higher.
 ** Ship S/N 30001 and subsequent.

Intentionally Blank

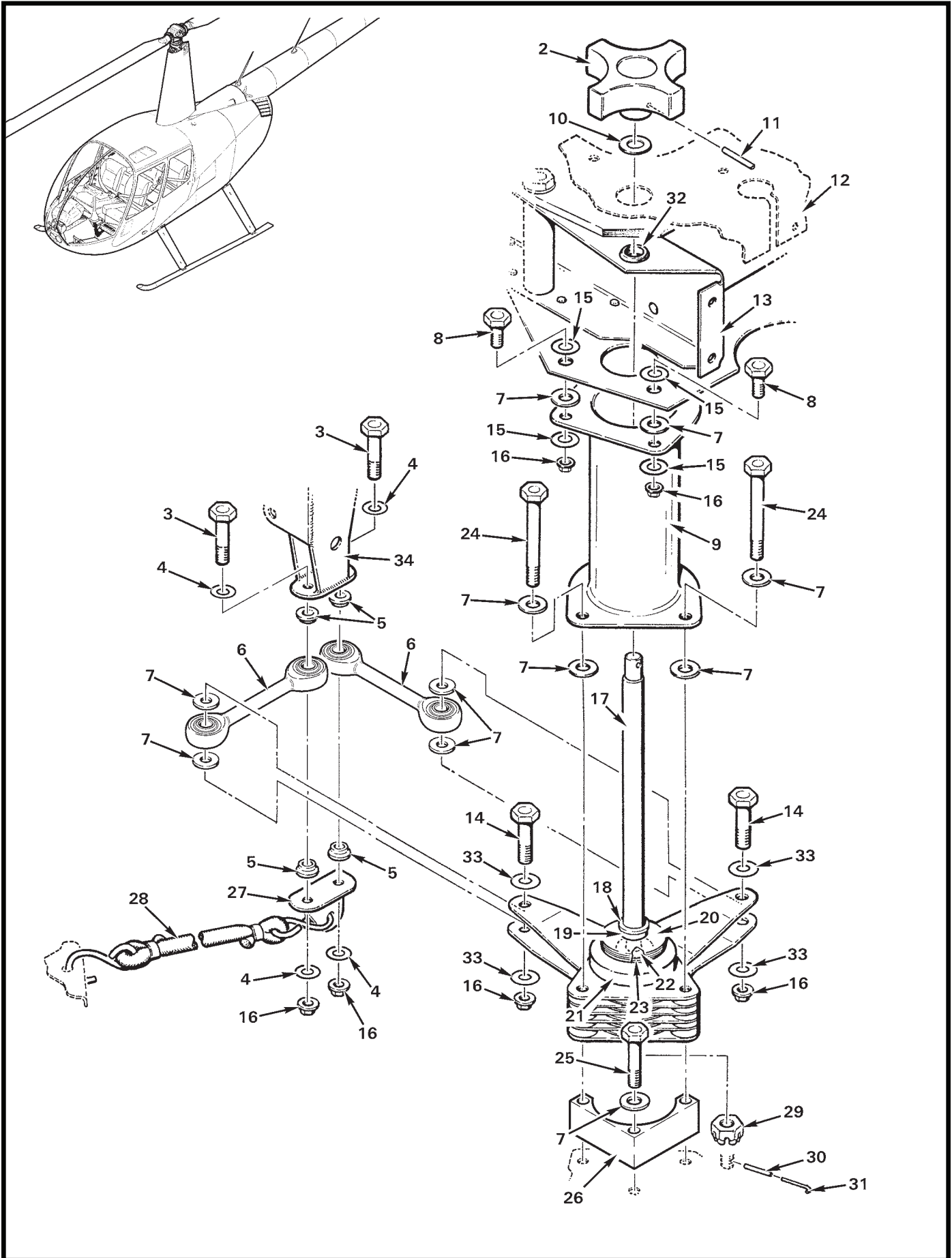

FIGURE AND INDEX NUMBER	PART NUMBER	DESCRIPTION	PARTS AVAIL	QTY PER ASSY
CYCLIC FRICTION ASSEMBLY				
67-17-1	C048-1	Cyclic Friction Assembly (Incl items 6, 8, 9, 13 thru 24, 29 thru 31, and 33)	X	1
2	A499-2	Knob	X	1
3	NAS6603-11	Bolt	X	2
4	A141-26	Washer	X	4
5	A341-1	Spacer	X	4
6	B564-1	Link	X	2
7	NAS1149F0363P	Washer ([6] with item 1)	X	10
8	NAS6603-2*	Bolt	X	2
9	D337-1*	Torque Tube Weldment	X	1
10	NAS1149F0463P	Washer (or NAS1149F0432P)	X	A/R
11	MS16562-35	Roll Pin	X	1
12	C444	Cover (Ref)		
13	C338-4*	Cyclic Box Assembly (Ref)		
	C338-1	Cyclic Box Assembly (Ref, Ship S/N 0001 – 0234; not shown)		
14	NAS6603-8	Bolt	X	2
15	NAS1149F0332P	Washer ([2] with item 1)	X	4
16	D210-3	Nut ([2] with item 1)	X	6
17	C130-2	Spacer	X	1
18	NAS1149F0463P	Washer	X	1
19	A130-18	Spacer	X	1
20	A478-1	Spring Washer	X	4
21	A497-1	Washer (Ref)		
22	NAS1149F0632P	Washer	X	1
23	NAS1149D0616J	Washer (installed between items 21 and 22)	X	A/R
24	NAS6603-18	Bolt (ship S/N 0235 and higher)	X	2
	NAS6603-25	Bolt (ship S/N 0001 thru 0234, without item 9 installed)	X	2
25	NAS6603-12	Bolt	X	1
26	C500-5	Spacer	X	1
27	A697-5**	Clip	X	1
28	C918-11*	Elastic Cord Assembly (10 lb)	X	A/R
	C918-12*	Elastic Cord Assembly (15 lb)	X	A/R
	C918-13*	Elastic Cord Assembly (20 lb)	X	A/R

NOTES * Ship S/N 0235 and subsequent.
 ** Manual control ships only.

Continues

FIGURE AND INDEX NUMBER	PART NUMBER	DESCRIPTION	PARTS AVAIL	QTY PER ASSY
CYCLIC FRICTION ASSEMBLY (Cont'd)				
67-17-29	MS17825-4	Nut	X	1
30	MS16562-14	Roll Pin	X	1
31	MS20995C32	0.032 in. dia. Safety Wire	X	A/R
32	NAS557-6A	Grommet	X	1
33	NAS1149D0316J*	Washer	X	4
	NAS1149F0332P	Washer (ship S/N 0001 thru 0234 at this location)	X	4
34	D320-1	Stick Assembly (Ref)		

NOTES * Ship S/N 0235 and subsequent.

Intentionally Blank

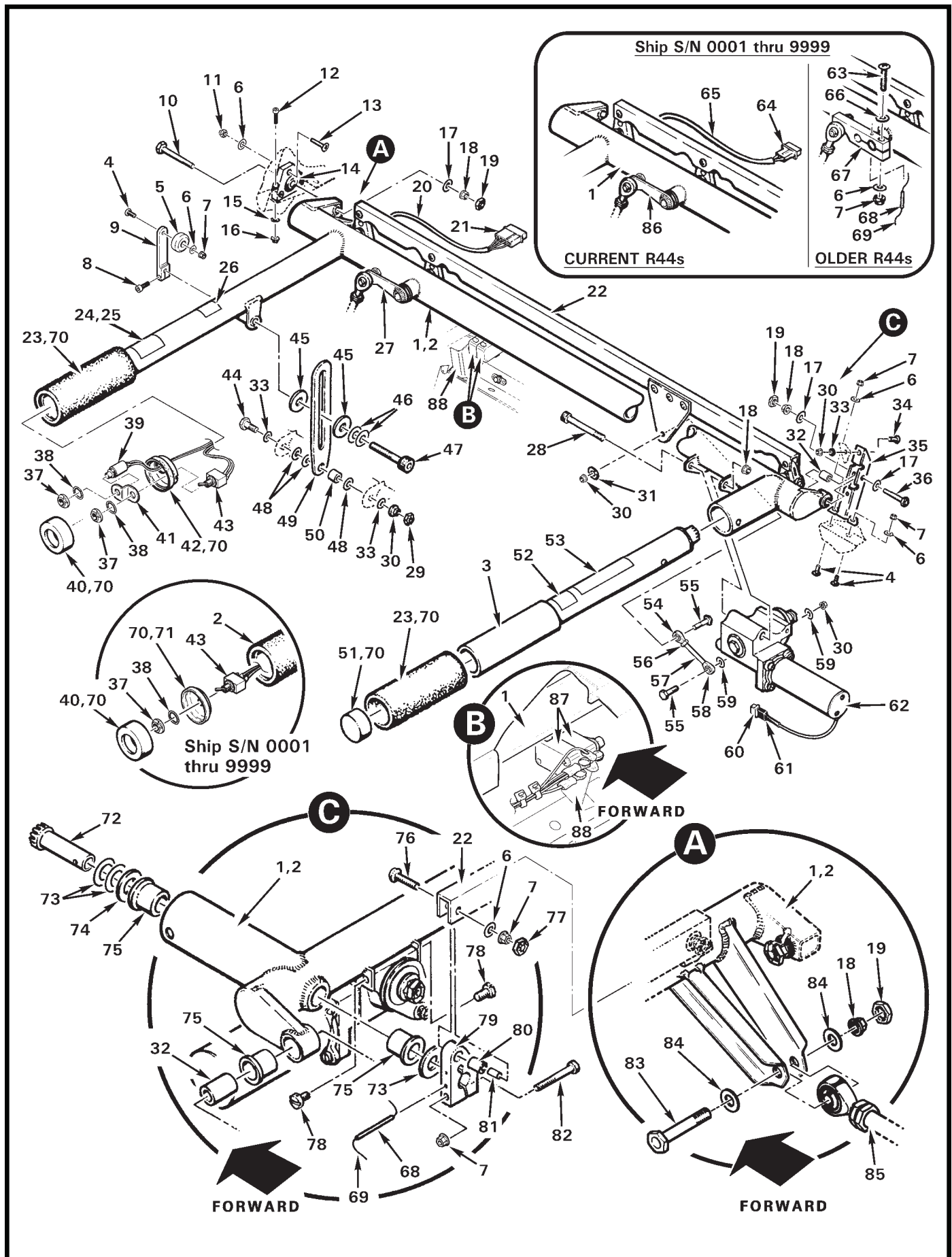

FIGURE AND INDEX NUMBER	PART NUMBER	DESCRIPTION	PARTS AVAIL	QTY PER ASSY
COLLECTIVE STICK ASSEMBLY				
67-21-1	C758-1 *	Stick Assembly – Collective (RH [pilot]; includes items 6, 7, 18, 22 thru 24, 26, 28, 30, 31, 40, 43, 54, 56 thru 59, 62, 64, 65, 68 thru 82, and 86)	X	1
2	C758-3**	Stick Assembly – Collective (RH [pilot]; includes items 6, 7, 18, 20 thru 23, 25 thru 28, 30, 31, 39 thru 43, 54, 56 thru 59, 62, 68 thru 70, 72 thru 82, and 86)	X	1
3	C758-2	Stick Assembly (LH [co-pilot]; includes items 23, 51, 52, and 70)	X	1
4	MS27039C0806	Screw	X	3
5	A431-1	Knob	X	1
6	NAS1149FN816P	Washer	X	10
7	MS21042L08	Nut	X	11
8	NAS1352-08LE9P	Screw	X	1
9	A332-2	Lever (supersedes A332-1)	X	1
10	NAS1304-17	Bolt (do not substitute NAS6604-17 bolt)	X	1
11	B340-4	Nut	X	3
12	NAS1352-06-12P	Screw	X	2
13	MS24694-S8	Screw	X	3
14	C329-3	Block Assembly – Collective Bearing	X	1
15	NAS1149FN632P	Washer	X	2
16	MS21042L06	Nut	X	2
17	NAS1149F0432P	Washer	X	3
18	D210-4	Nut	X	3
19	B330-13	Palnut	X	2
20	B158-3	Heat Shrink	X	A/R
21	B263-36	Housing	X	1
	B263-1	Pin	X	4
22	C328-1	Connecting Rod Assembly	X	1
23	A601-1	Grip (install using item 70)	X	2
24	A654-79*	Decal – “Gov, On-Off”	X	1
25	D682-8**	Decal – “Gov, On-Off/Start/Throttle (Open)”	X	1
26	A654-7	Decal – “Friction Increase”	X	1
27	C341-1	Arm (Ref; see Figure 76-5)		
28	NAS1351-4-28P	Screw	X	1
29	B330-7	Palnut	X	1
30	D210-3	Nut	X	3
31	NAS1149F0363P	Washer	X	1

NOTES * Ship S/N 0001 thru 9999.
 ** Ship S/N 10001 and subsequent.

Continues

FIGURE AND INDEX NUMBER	PART NUMBER	DESCRIPTION	PARTS AVAIL	QTY PER ASSY
COLLECTIVE STICK ASSEMBLY (Cont'd)				
67-21-32	A105-6	Journal	X	1
33	NAS1149F0332P	Washer	X	3
34	MS27039C1-08	Screw	X	1
35	C303-1	Support	X	1
36	NAS6604-11	Bolt	X	1
37	B227-4	Dress Nut	X	1
38	B227-3	Lockwasher	X	1
39	B280-5*	Switch Assembly (engine starter, includes items 37 and 38) . .	X	1
40	A959-2	End Cap (install using item 70)	X	1
41	B252-7*	Bracket	X	1
42	B252-8*	Mount (install using item 70)	X	1
43	B280-1	Switch Assembly (Incl items 37 and 38)	X	1
44	NAS6603-5	Bolt	X	1
45	A141-20	Washer (arrange teflon facing item 49)	X	2
46	B0500-022-S	Belleville Washer	X	2
47	NAS1352-4-24P	Screw	X	1
48	NAS1149F0463P	Washer (or NAS1149F0432P)	X	A/R
49	A333-1	Stop	X	1
50	A130-4	Spacer	X	1
51	A959-1	End Cap (install using item 70)	X	1
52	A654-6	Decal – "Throttle Open"	X	1
53	A654-21	Decal – "No Stowage"	X	2
54	A127-3	Rod End	X	1
55	NAS6603-6	Bolt	X	2
56	AN315-3R	Nut	X	1
57	A430-3	Tube	X	1
58	A498-1	Rod End	X	1
59	NAS620-10L	Washer	X	2
60	B263-32	Housing	X	1
	B263-1	Pin	X	2
61	B158-3	Heat Shrink (around wires)	X	1
	B158-8	Heat Shrink (around connector)	X	2

NOTES * Ship S/N 10001 and subsequent.

Continues

FIGURE AND INDEX NUMBER	PART NUMBER	DESCRIPTION	PARTS AVAIL	QTY PER ASSY
COLLECTIVE STICK ASSEMBLY (Cont'd)				
67-21-62	B247-5	Governor Assembly (14-volt; Includes items 60 and 61. R44 I S/N 0001 thru 2624; R44 Cadet 30001 thru 30060, 30062 thru 30070; R44 II S/N 10001 thru 14363, and 14365 thru 14411.)	X	1
	B247-9	Governor Assembly (28-volt; Includes items 60 and 61. R44 I S/N 2625 and subsequent; R44 Cadet 30061, 30071 and subsequent; R44 II S/N 14364, 14412 and subsequent.)	X	1
63	MS27039C0816	Screw	X	1
64	B263-32	Housing	X	1
	B263-1	Pin	X	2
65	B158-2	Heat Shrink	X	A/R
66	NAS1149FN832P	Washer	X	1
67	C342-1*	Arm	X	1
68	MS16562-18	Roll Pin	X	4
69	MS20995C32	0.032 in. dia. Safety Wire	X	A/R
70	B270-15	Adhesive	X	A/R
71	B252-4*	Mount (install using item 70)	X	1
72	A765-2	Coupling Assembly (Ref)		
73	NAS1149D0616J	Washer	X	A/R
74	A141-16	Washer	X	6
75	A139-1	Bearing	X	7
76	MS27039C0810	Screw	X	3
77	B330-6	Palnut	X	3
78	NAS1352N08-4	Screw	X	2
79	A325-1	Arm	X	3
80	04DU04	Bushing	X	3
81	A105-5	Journal	X	3
82	A486-2	Screw	X	3
83	NAS6604-9	Bolt	X	1
84	A141-11	Washer	X	2
85	C121-19	Push-Pull Tube (Ref, see Figure 67-41)		
86	C341-3*	Arm (Ref, see Figure 76-1)		
87	V3-1	Switch – Low RPM Warning/Hourmeter (Ref, see Figure 96-57)		
88	C015	Cabin Assembly (Ref)		

NOTES * Ship S/N 0001 thru 9999.

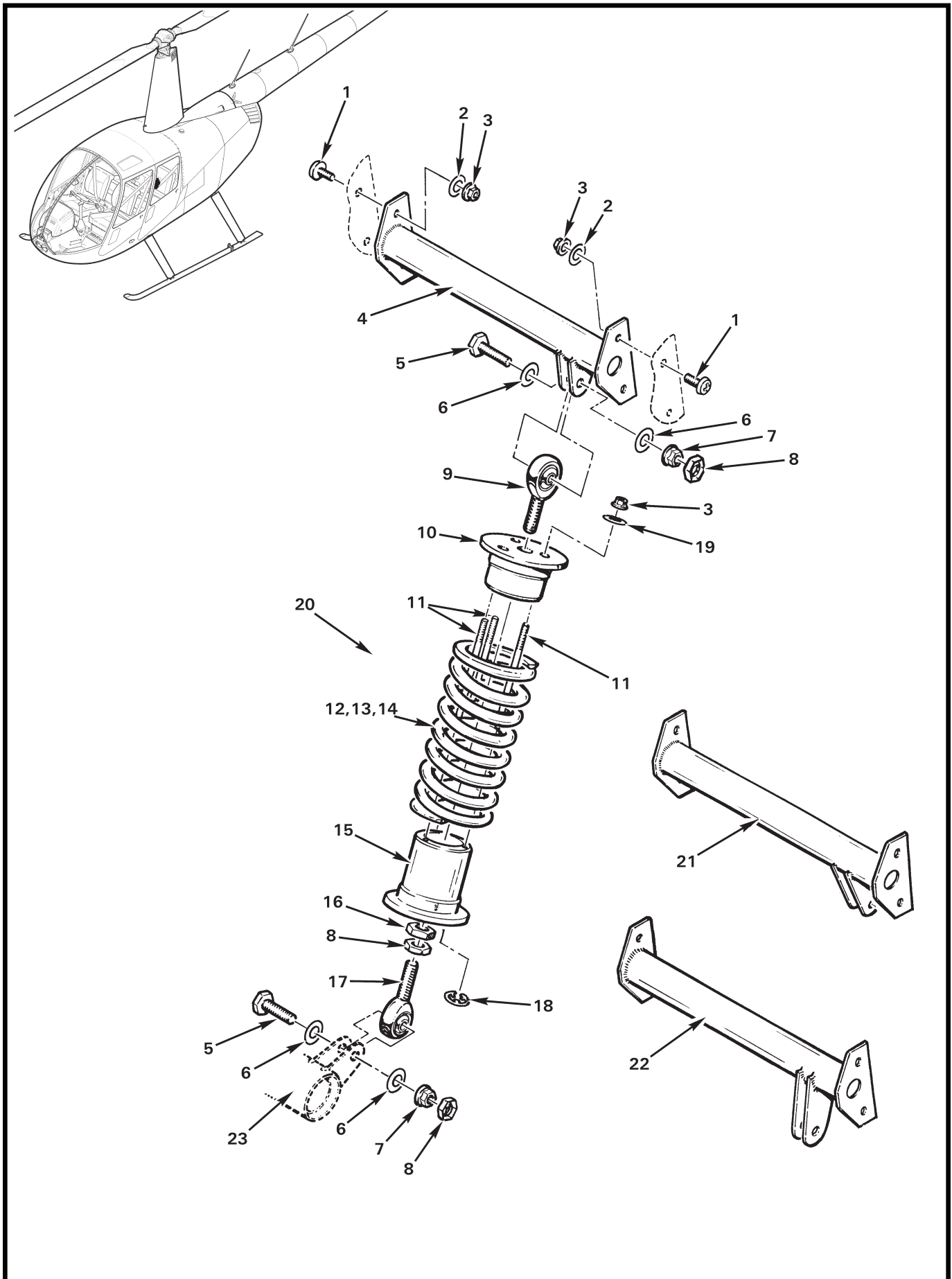

FIGURE AND INDEX NUMBER	PART NUMBER	DESCRIPTION	PARTS AVAIL	QTY PER ASSY
COLLECTIVE SPRING ASSEMBLY - ELECTRIC TRIM				
67-25-1	MS27039C1-06	Screw	X	4
2	NAS1149FO332P	Washer	X	4
3	MS21042L3	Nut	X	7
4	C427-7	Support Assembly (use only with C038-5, -6, or -7 assy)	X	1
5	NAS6604-7	Bolt	X	2
6	NAS1149FO432P	Washer	X	4
7	MS21042L4	Nut	X	2
8	B330-13	Palnut	X	3
9	B292-4	Rod End (left-hand thread)	X	1
10	C426-1	Cap	X	1
11	C428-2	Rod (for use with C038-5, -6, or -7 assemblies only)	X	3
12	A429-11	Spring (strong; 156 lb/in., silver-gold plating)	X	1
13	A429-12	Spring (medium; 87 lb/in., green primer color)	X	1
14	A429-13	Spring (weak; 61 lb/in., gray primer color)	X	1
15	C426-2	Cap	X	1
16	AN316-4R	Nut	X	1
17	A127-4	Rod End	X	1
18	MS16633-2018	Retaining Ring* (Install on C428-2 rods to remove or install C038-5, -6, or -7 Collective Spring Assembly)	X	3
19	AN960PD10L	Washer	X	3
20	C038-5	Collective Spring Assembly (strong; includes items 3 [3], 5 thru 11, 12, and 15 thru 19. Replaces C038-3 and -4 assemblies.)	X	1
	C038-6	Collective Spring Assembly (medium; includes items 3 [3], 5 thru 11, 13, and 15 thru 19)	X	1
	C038-7	Collective Spring Assembly (weak; includes items 3 [3], 5 thru 11, 14, and 15 thru 19)	X	1
21	C427-5	Support Assembly (Ref, superseded by item 4. Use only with item 20. No longer available.)		
22	C427-3	Support Assembly (Ref, superseded by item 21. Use only with C038-3 and -4 collective spring assemblies. No longer available.)		
23	C326-7	Bellcrank (Ref; see also Figure 67-45)		
24	A429-9	Spring (strong; 208 lb/in., silver-gold plating. Use only with C038-3 assembly; not shown.)	X	1
25	A429-10	Spring (weak; 114 lb/in., primer color. Use only with C038-4 assembly; not shown.)	X	1

NOTES * Not for in-flight use.

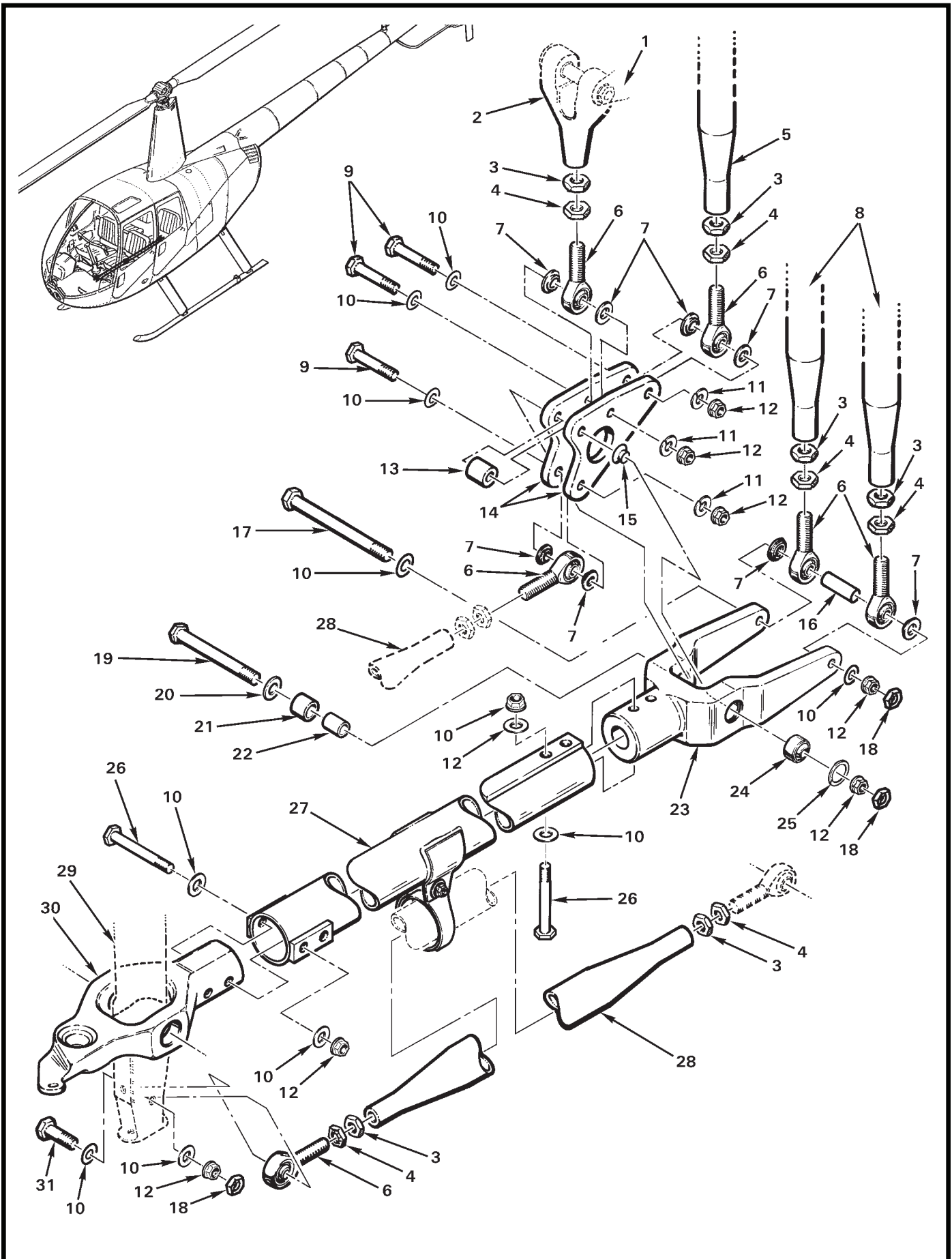

FIGURE AND INDEX NUMBER	PART NUMBER	DESCRIPTION	PARTS AVAIL	QTY PER ASSY
		MAIN ROTOR CONTROLS*		
67-27-1	C334	Aft Support Assembly (Ref, see Figure 67-41)		
2	A205-3	Fork	X	1
3	AN316-5R	Nut	X	6
4	B330-16	Palnut	X	6
5	C121-30	Push-Pull Tube (Ref; to jackshaft assembly. See Figure 67-53.)	X	1
6	B163-2	Rod End	X	6
7	A115-1	Spacer	X	8
8	C121-28	Push-Pull Tube Assembly (Ref; to forward servos. See Figure 29-1.)	X	2
9	NAS6604-15	Bolt	X	3
10	NAS1149F0432P	Washer	X	3
11	B332-441	Lockwasher	X	3
12	D210-4	Nut	X	10
13	A130-8	Spacer	X	1
14	C958-6	Bellcrank	X	2
15	A137-1	Spacer	X	1
16	C130-40	Spacer	X	1
17	NAS6604-46	Bolt	X	1
18	B330-13	Palnut	X	3
19	NAS6604-36	Bolt	X	1
20	NAS1149F0463P	Washer	X	1
21	O6DU06	Bearing	X	1
22	A105-6	Journal	X	1
23	D696-4	Yoke Assembly (Small rod end; includes D696-2 yoke, and items 21, 24, and 25.)	X	1
	D696-2	Yoke	O	1
24	B115-1	Bearing (install using B270-11 adhesive)	X	1
25	WH-62-S02	Ring	X	1
26	NAS6604-25	Bolt	X	4
27	C319-5	Torque Tube	X	1
28	C121-1	Push-Pull Tube Assembly (Incl items 3, 4, and 6)	X	1

NOTES * Ship S/N 1001 and subsequent.

Continues

FIGURE AND INDEX NUMBER	PART NUMBER	DESCRIPTION	PARTS AVAIL	QTY PER ASSY
MAIN ROTOR CONTROLS* (Cont'd)				
67-27-29	C069	Cyclic Control Assembly (Ref)		
30	C177-3	Pivot	X	1
31	NAS6604-9	Bolt	X	1
32	C175-4	Cyclic Pivot Assembly (Ref; includes items 2 thru 4 [4 each], 6, 7, and 9 thru 28. Also includes items 1, 4, 20, 37, 39, and 41 from Figure 67-41.)		

NOTES * Ship S/N 1001 and subsequent.

Intentionally Blank

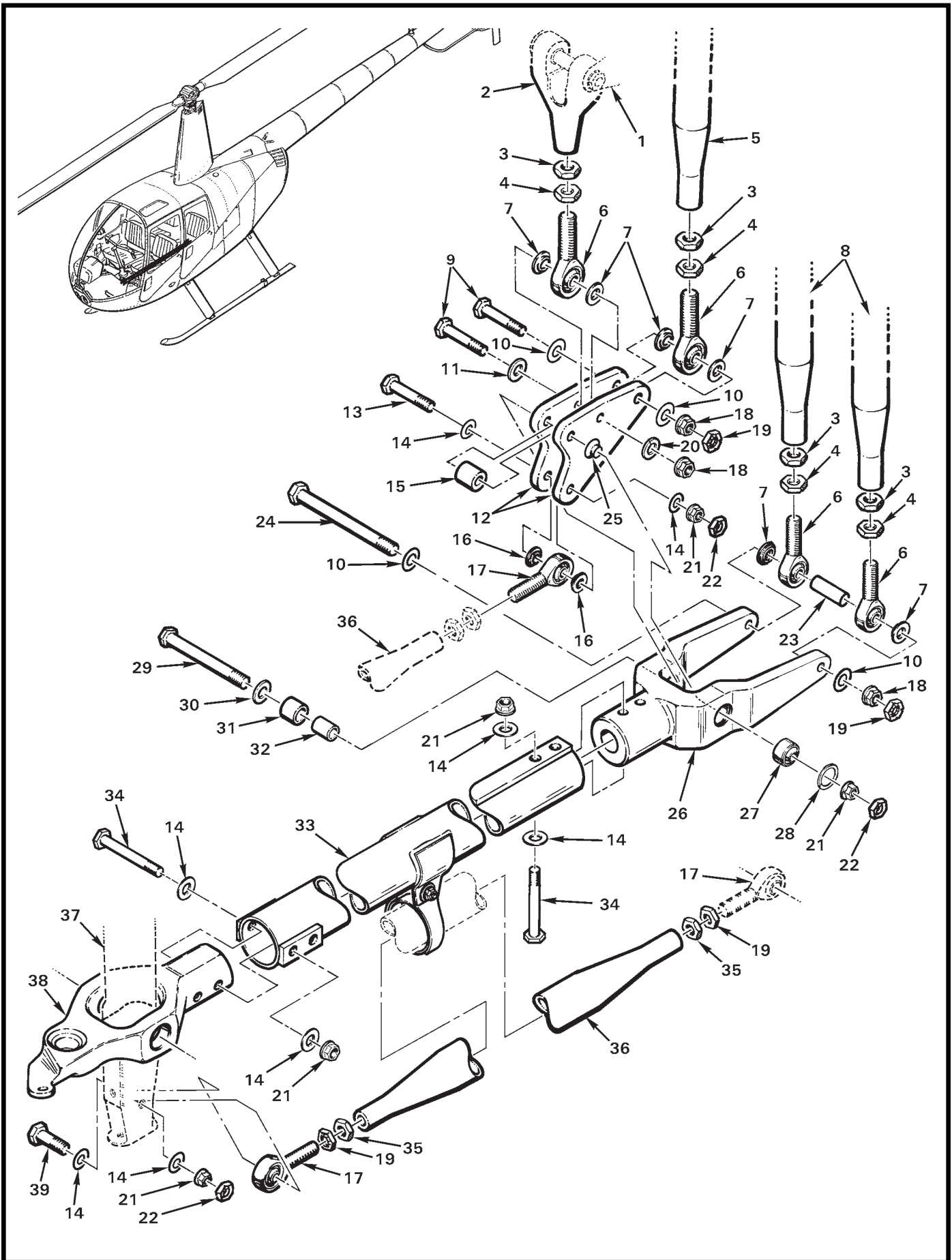

FIGURE AND INDEX NUMBER	PART NUMBER	DESCRIPTION	PARTS AVAIL	QTY PER ASSY
		MAIN ROTOR CONTROLS*		
67-31-1	C334	Aft Support Assembly (Ref, see Figure 67-45)		
2	A205-5	Fork	X	1
3	AN316-6R	Nut	X	4
4	B330-19	Palnut	X	4
5	C121-4	Push-Pull Tube Assembly (Ref; includes items 3, 4, and 6)		
6	D173-1	Rod End	X	4
7	C115-1	Spacer	X	6
8	C121-24**	Tube (Ref)		
9	NAS6605-16	Bolt	X	2
10	NAS1149F0532P	Washer	X	4
11	NAS1149F0563P	Washer	X	1
12	C958-5	Bellcrank	X	2
13	NAS6604-16	Bolt	X	1
14	NAS1149F0432P	Washer	X	13
15	A130-8	Spacer	X	1
16	A115-1	Spacer	X	2
17	A101-4	Rod End	X	2
18	D210-5	Nut	X	3
19	B330-16	Palnut	X	2
20	B332-45	Washer	X	1
21	D210-4	Nut	X	8
22	B330-13	Palnut	X	3
23	C130-7	Spacer	X	1
24	NAS1305-46	Bolt	X	1
25	A137-1	Spacer	X	1
26	D696-4	Yoke Assembly (Large rod end; includes D696-1 yoke, and items 27, 28, and 31.)	X	1
	D696-1	Yoke	O	1
27	B115-1	Bearing (install using B270-11 adhesive)	X	1
28	WH-62-S02	Ring	X	1
29	NAS6604-36	Bolt	X	1
30	NAS1149F0463P	Washer	X	1

NOTES * Ship S/N 1000 and prior with hydraulic controls.
 ** Order items 3, 4, and 6 as required.

Continues

FIGURE AND INDEX NUMBER	PART NUMBER	DESCRIPTION	PARTS AVAIL	QTY PER ASSY
MAIN ROTOR CONTROLS* (Cont'd)				
67-31-31	O6DU06	Bearing	X	1
32	A105-6	Journal	X	1
33	C319-5	Torque Tube	X	1
34	NAS6604-25	Bolt	X	4
35	AN316-5R	Nut	X	2
36	C121-1	Push-Pull Tube Assembly (Incl items 17, 19, and 35)	X	1
37	C069	Cyclic Control Assembly (Ref)		
38	C177-3	Pivot	X	1
39	NAS6604-9	Bolt	X	1
40	C175-3	Cyclic Pivot Assembly* (Ref; includes items 2 thru 4, 6, 7, 9 thru 16, 18 thru 34, and 36. Also includes items 12, 36, and 41 from Figure 67-45.)		

NOTES * Ship S/N 1000 and prior with hydraulic flight controls.

Intentionally Blank

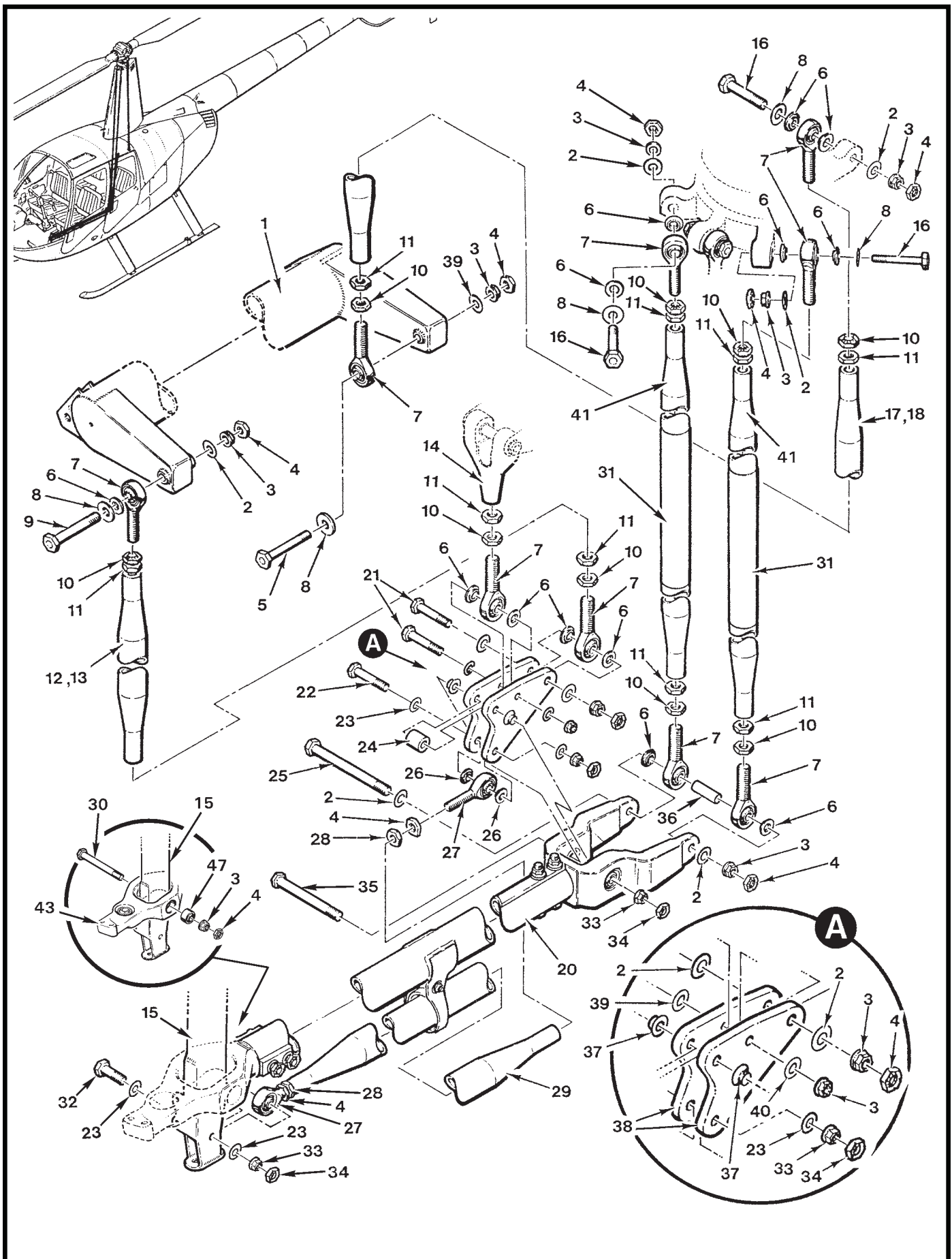

FIGURE AND INDEX NUMBER	PART NUMBER	DESCRIPTION	PARTS AVAIL	QTY PER ASSY
MAIN ROTOR CONTROLS				
67-35-1	C337-1	Jackshaft Assembly (Ref, see Figure 67-59)		
2	NAS1149F0532P	Washer	X	10
3	D210-5	Nut	X	8
4	B330-16	Palnut	X	9
5	NAS6605-25	Bolt	X	1
6	C115-1	Spacer	X	13
7	D173-1	Rod End	X	13
8	C141-1	Washer	X	4
9	NAS6605-26	Bolt	X	1
10	B330-19	Palnut	X	9
11	AN316-6R	Nut	X	9
12	C121-3	Push-Pull Tube Assembly (Ref; includes items 7, 10, 11, and 13)		
13	—	Tube (Ref)		
14	A205-5	Fork Assembly (Ref, see also Figure 67-45)		
15	C320	Cyclic Stick Assembly (Ref)		
16	NAS6605-19	Bolt	X	3
17	C121-5	Push-Pull Tube Assembly (Incl items 7, 10, 11, 18, and 42) . .	X	1
18	—	Tube (Ref)		
19	C198-1	Swashplate – Lower (Ref)		
20	C319-3	Torque Tube (Ref)		
21	NAS6605-16	Bolt	X	2
22	NAS6604-16	Bolt	X	1
23	NAS1149F0432P	Washer	X	4
24	A130-8	Spacer	X	1
25	NAS1305-46	Bolt	X	1
26	A115-1	Spacer	X	2
27	A101-4	Rod End	X	2
28	AN316-5R	Nut	X	2
29	C121-1	Push-Pull Tube Assembly (Incl items 4, 27, and 28)	X	1
30	NAS1305-35	Bolt	X	1
31	A143-4	Sleeve (supersedes A143-1)	X	2

NOTES

Continues

FIGURE AND INDEX NUMBER	PART NUMBER	DESCRIPTION	PARTS AVAIL	QTY PER ASSY
MAIN ROTOR CONTROLS (Cont'd)				
67-35-32	NAS6604-8	Bolt	X	1
33	D210-4	Nut	X	3
34	B330-13	Palnut	X	3
35	NAS1304-37	Bolt (do not substitute with NAS6604-37)	X	1
36	C130-7	Spacer	X	1
37	A137-2	Spacer	X	2
38	C958-5	Bellcrank	X	2
39	NAS1149F0532P	Washer	X	2
40	B332-45	Washer	X	1
41	C121-8*	Tube	X	2
42	A143-5	Sleeve (not shown; supersedes A143-3)	X	1
43	C177-5	Pivot Assembly (includes item 44, [2 installed])	X	1
	C177-4	Pivot Assembly (Ref, no longer available. Superseded by C177-5 pivot assembly. Not shown.)		

NOTES * Order items 7, 10, 11, and 31, as required.

Intentionally Blank

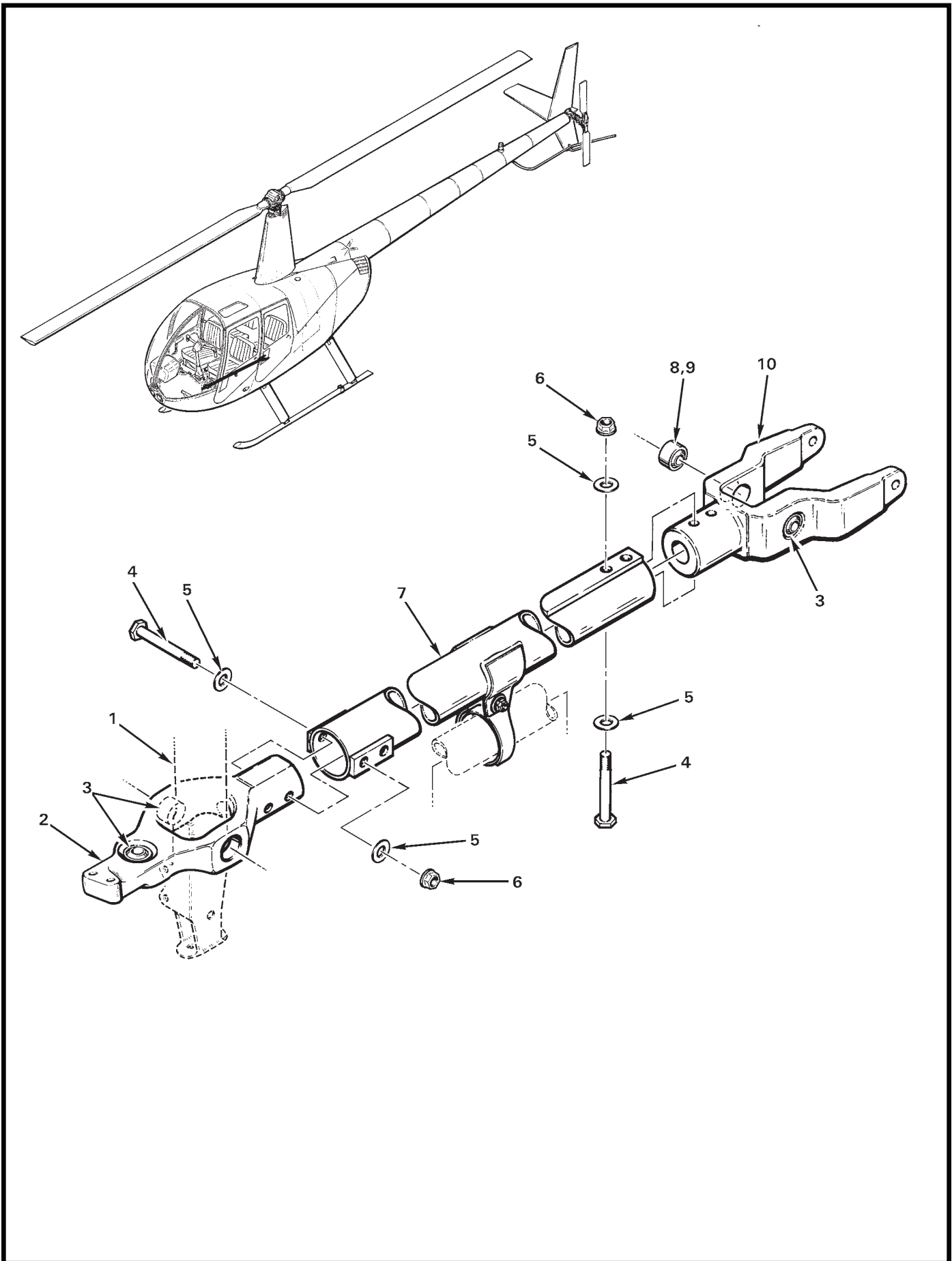

FIGURE AND INDEX NUMBER	PART NUMBER	DESCRIPTION	PARTS AVAIL	QTY PER ASSY
TORQUE TUBE INSTALLATION				
67-39-1	C320-1	Cyclic Stick Assembly (Ref)		
2	C177-4	Pivot Assembly (Ref, no longer available)		
3	A103-5	Bearing (staked in place; [2] on item 2, [1] on item 10)	O	3
4	NAS6604-25	Bolt	X	1
5	NAS1149F0432P	Washer	X	4
6	MS21042L4	Nut	X	3
7	C319-3	Torque Tube Assembly	X	1
8	A103-5	Bearing (install using item 9)	X	2
9	B270-10	Adhesive	X	A/R
10	C176-3	Yoke (Ref, no longer available)		
NOTES				

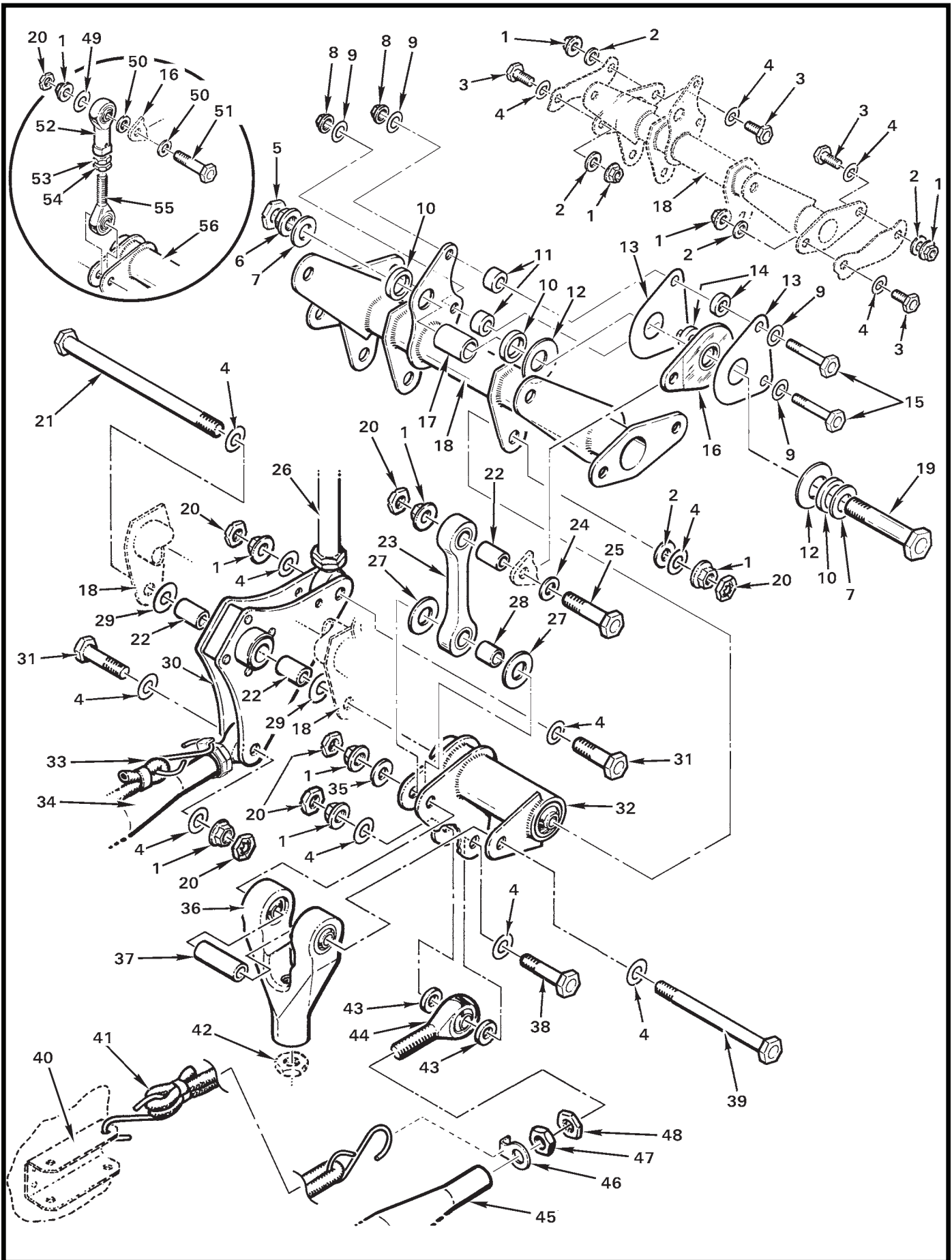

FIGURE AND INDEX NUMBER	PART NUMBER	DESCRIPTION	PARTS AVAIL	QTY PER ASSY
AFT SUPPORT ASSEMBLY*				
67-41-1	D210-4	Nut	X	10
2	NAS1149F0463P	Washer	X	5
3	NAS6604-2	Bolt	X	4
4	NAS1149F0432P	Washer	X	12
5	B330-19	Palnut	X	1
6	D210-6	Nut	X	1
7	NAS1149F0663P	Washer	X	2
8	MS21042L3	Nut	X	2
9	NAS1149F0332P	Washer	X	4
10	C130-25	Spacer	X	3
11	A130-21	Spacer	X	2
12	B1000-035-S	Spring Washer	X	2
13	D336-1	Plate	X	2
14	C130-24	Spacer	X	2
15	NAS6603-6	Bolt	X	2
16	B249-6	Arm	X	1
17	B250-13	Journal	X	1
18	C315-9	Support	X	1
19	NAS6606-11	Bolt	X	1
20	B330-13	Palnut	X	4
21	NAS6604-67	Bolt (alternate part no. C311-2)	X	1
22	A105-3	Journal	X	3
23	C327-1	Link (ship S/N 1162 and subsequent)	X	1
24	A141-11	Washer	X	1
25	NAS6604-9	Bolt	X	1
26	C343-1	Push-Pull Tube Assembly – Tail Rotor Control (Ref, see Figure 67-89)		
27	A214-11	Washer	X	2
28	A105-14	Journal	X	1
29	A141-3	Washer	X	2
30	C317-1	Bellcrank Assembly	X	1
31	NAS6604-8	Bolt	X	1

NOTES * Hydraulic controls.

Continues

FIGURE AND INDEX NUMBER	PART NUMBER	DESCRIPTION	PARTS AVAIL	QTY PER ASSY
AFT SUPPORT ASSEMBLY* (Cont'd)				
67-41-32	C334-4	Bellcrank Assembly (ship S/N 0760 and higher)	X	1
33	A918	Elastic Cord (Ref, see Figure 67-85)		
34	C121-9	Push-Pull Tube Assembly – Tail Rotor Control (Ref, see Figure 67-85)		
35	A214-3	Washer	X	1
36	A205-3	Fork Assembly	X	1
37	C130-12	Spacer	X	1
38	NAS6604-11	Bolt	X	1
39	NAS6604-37	Bolt	X	1
40	A697-3	Anchor (Ref)		
41	C918-15	Elastic Cord (collective)	X	1
42	AN316-5R	Nut (Ref, see Figure 67-35)		
43	A130-47	Spacer	X	2
44	A101-4	Rod End	X	2
45	C121-19	Push-Pull Tube Assembly (Incl items 44, 47, and 48)	X	1
46	A697-6	Tab	X	1
47	AN316-5R	Nut	X	2
48	B330-16	Palnut	X	2
* * *				
49	NAS1149F0432P**	Washer	X	2
50	A141-11**	Washer	X	1
51	NAS6604-8**	Bolt	X	1
52	B316-4**	Rod End	X	1
53	AN316-4R**	Nut	X	1
54	B330-13**	Palnut	X	1
55	A127-4**	Rod End	X	1
56	C334-3	Bellcrank Assembly (Ref)		

NOTES * Hydraulic controls.
 ** Ship S/N 1161 and prior.

Intentionally Blank

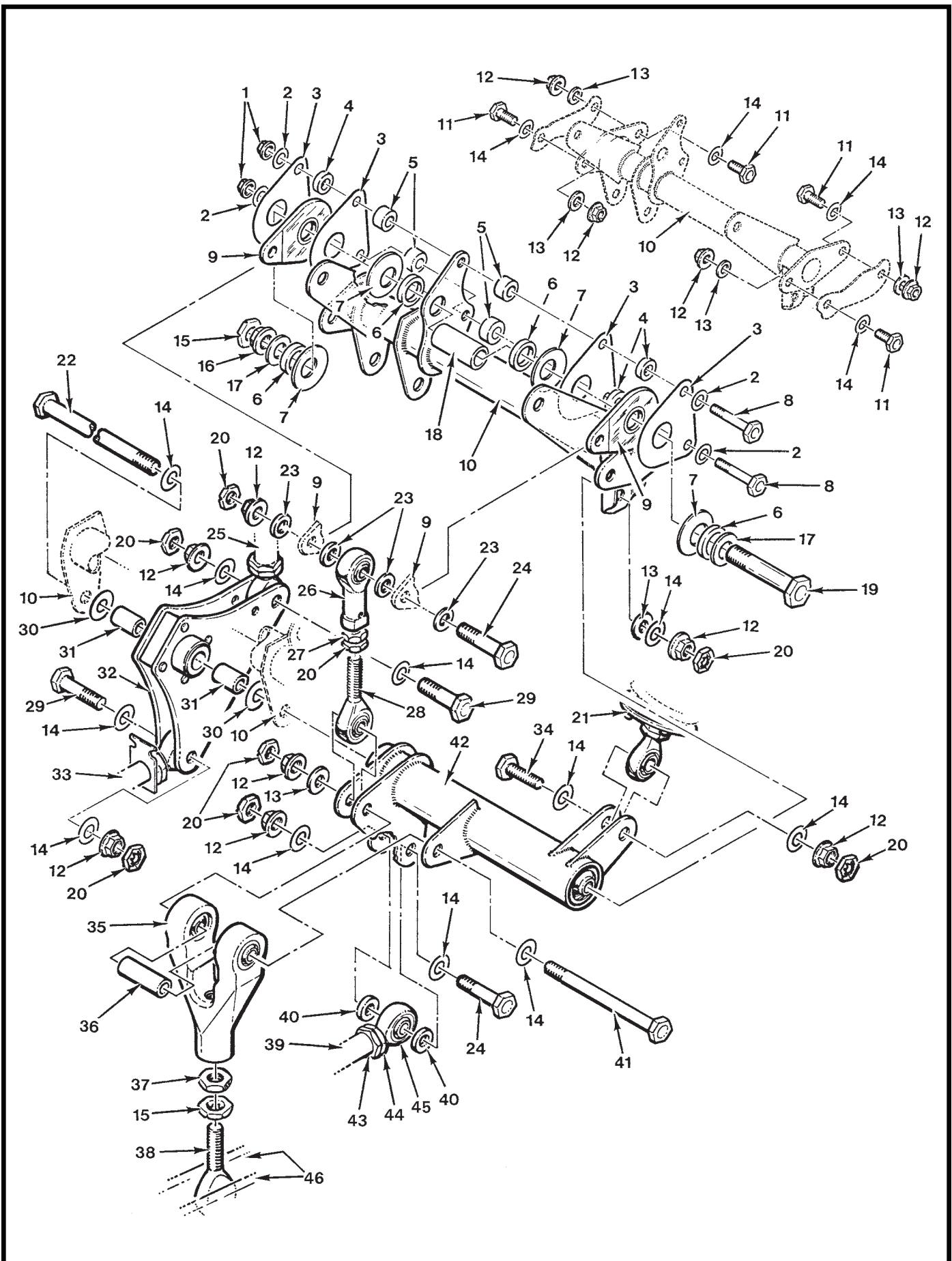

FIGURE AND INDEX NUMBER	PART NUMBER	DESCRIPTION	PARTS AVAIL	QTY PER ASSY
AFT SUPPORT ASSEMBLY				
67-45-1	MS21042L3	Nut	X	2
2	NAS1149F0332P	Washer	X	4
3	D336-1	Plate	X	4
4	C130-24	Spacer	X	4
5	A130-21	Spacer	X	4
6	C130-25	Spacer	X	4
7	B1000-050-S	Spring Washer	X	4
8	NAS6603-11	Bolt	X	2
9	B249-6	Arm Assembly	X	2
10	C315-7	Weldment – Aft Support Assembly	X	1
11	NAS6604-2	Bolt	X	4
12	D210-4	Nut	X	11
13	NAS1149F0463P	Washer	X	6
14	NAS1149F0432P	Washer	X	15
15	B330-19	Palnut	X	2
16	D210-6	Nut	X	1
17	NAS1149F0663P	Washer	X	2
18	B250-11	Journal	X	1
19	NAS6606-17	Bolt	X	1
20	B330-13	Palnut	X	7
21	C038	Collective Spring Assembly (Ref, see Figure 67-25)		
22	NAS6604-105	Bolt (alternate part no. C311-1)	X	1
23	A141-11	Washer	X	4
24	NAS6604-11	Bolt	X	2
25	C343-1	Push-Pull Tube Assembly (Ref, see Figure 67-89)		
26	B316-4	Rod End	X	1
27	AN316-4R	Nut	X	1
28	A127-4	Rod End	X	1
29	NAS6604-8	Bolt	X	2
30	A141-3	Washer	X	2
31	A105-3	Journal	X	2

NOTES

Continues

FIGURE AND INDEX NUMBER	PART NUMBER	DESCRIPTION	PARTS AVAIL	QTY PER ASSY
AFT SUPPORT ASSEMBLY (Cont'd)				
67-45-32	C317-1	Bellcrank Assembly	X	1
33	C121-9	Push-Pull Tube Assembly (Ref, see Figure 67-85)		
34	NAS6604-7	Bolt	X	1
35	A205-5	Fork Assembly	X	1
36	C130-12	Spacer	X	1
37	AN316-6R	Nut	X	1
38	D173-1	Rod End	X	1
39	C121-19	Push-Pull Tube Assembly (Incl items 43 thru 45)	X	1
40	A130-47	Spacer	X	2
41	NAS1304-38	Bolt	X	1
42	C326-7	Bellcrank	X	1
43	AN316-5R	Nut	X	2
44	B330-16	Palnut	X	2
45	A101-4	Rod End	X	2
46	C958-5	Bellcrank (Ref, see Figure 67-35)		
NOTES				

Intentionally Blank

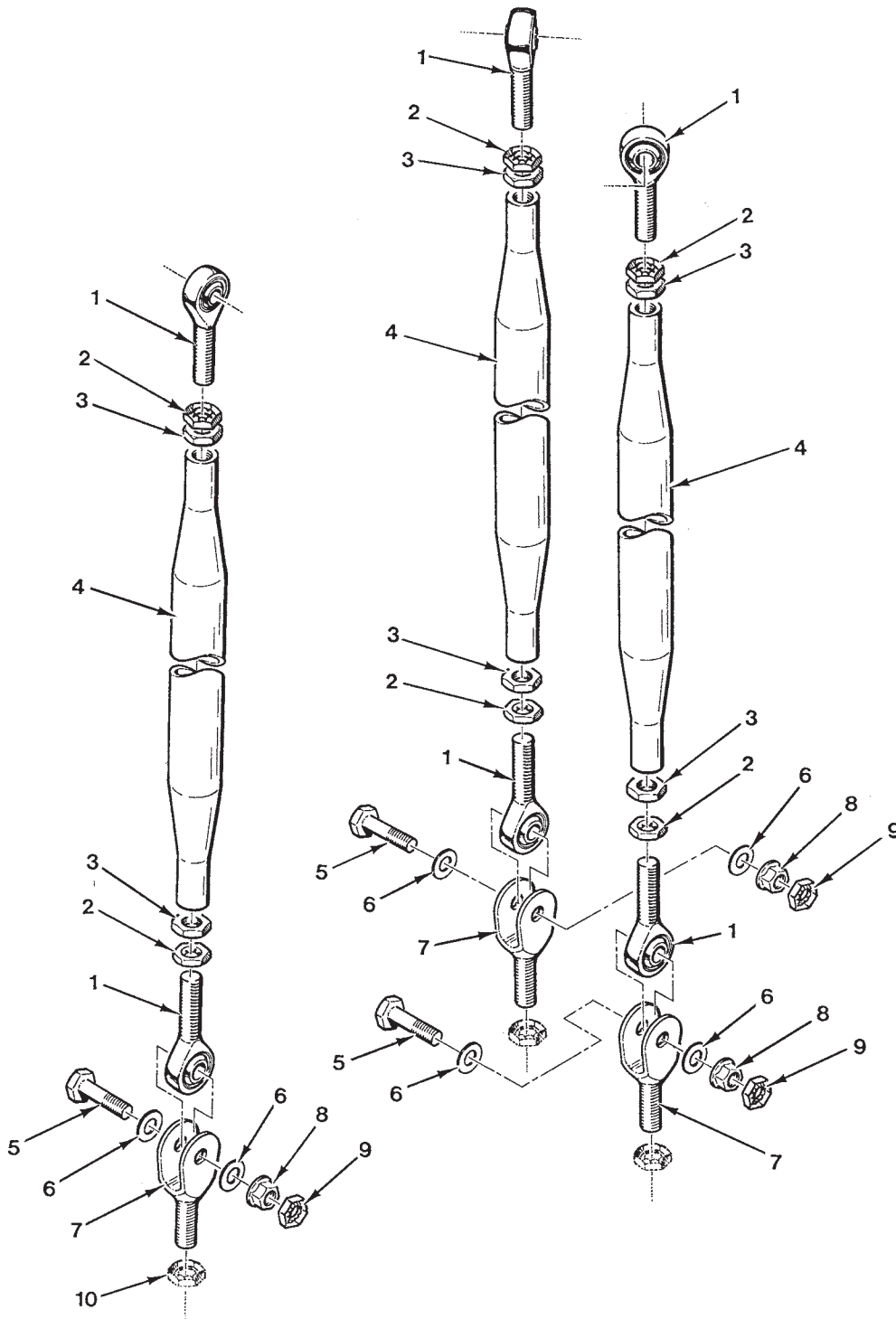

FIGURE AND INDEX NUMBER	PART NUMBER	DESCRIPTION	PARTS AVAIL	QTY PER ASSY
PUSH-PULL TUBE ASSEMBLIES				
67-49-1	D173-2	Rod End	X	2
2	B330-19	Palnut	X	2
3	AN316-6R	Nut	X	2
4	C121-31	Push-Pull Tube Assembly (Includes items 1 thru 3. Supersedes C121-25; must use C121-31 on R44 II.)	X	3
5	NAS6605-9	Bolt	X	3
6	NAS1149F0532P	Washer	X	6
7	D200-1 *	Clevis (Ref)	X	3
8	D210-5	Nut	X	3
9	B330-16	Palnut	X	3
10	B330-19*	Palnut (Ref)		

NOTES * See also Figure 29-3 and Figure 29-1.

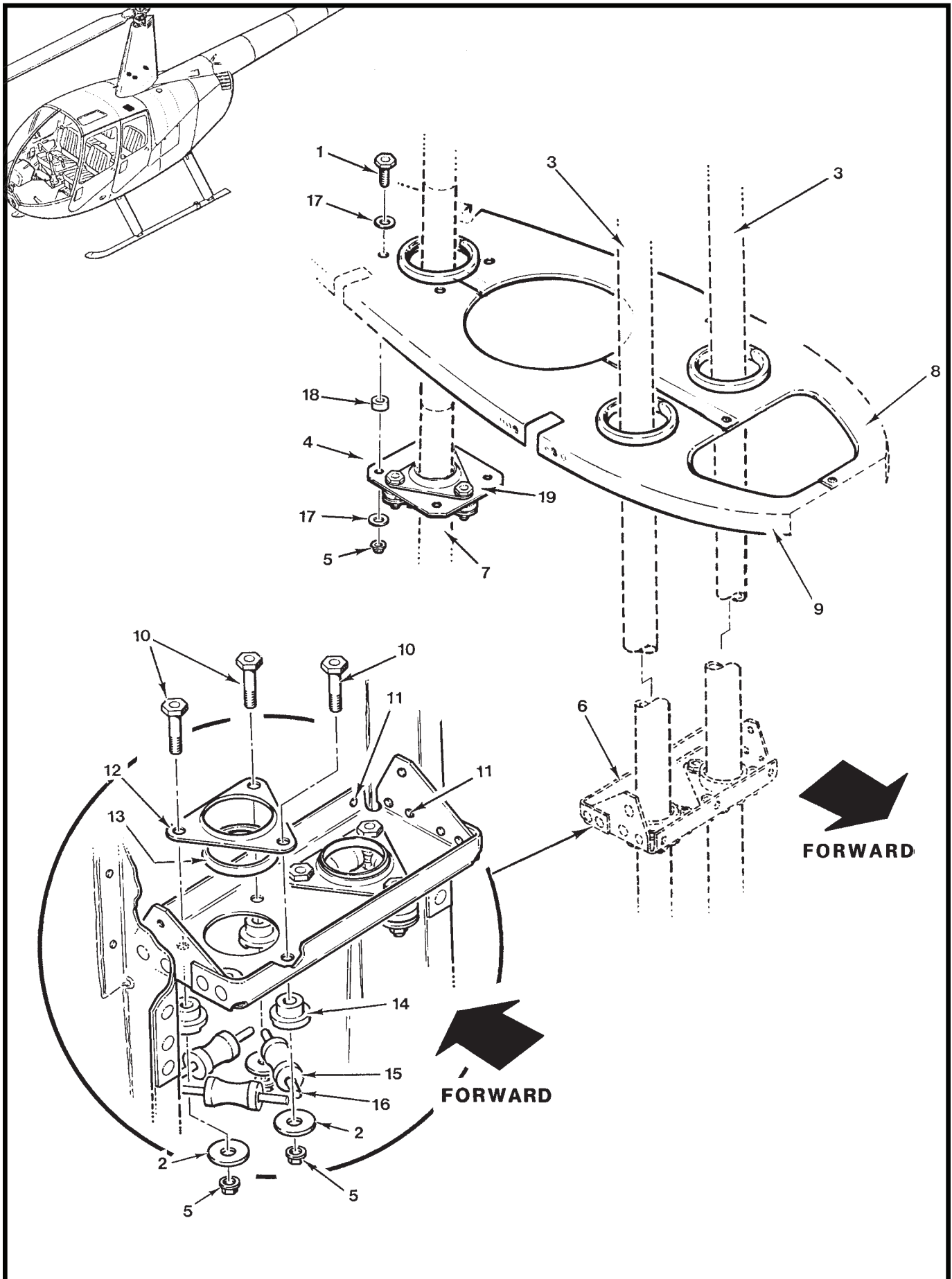

FIGURE AND INDEX NUMBER	PART NUMBER	DESCRIPTION	PARTS AVAIL	QTY PER ASSY
PUSH-PULL TUBE GUIDE INSTALLATION*				
67-51-1	NAS6603-4	Bolt	X	4
2	A141-17	Washer	X	6
3	C121-7**	Push-Pull Tube Assembly (Ref)		
4	B439-2	Guide Assembly – Aft (Ship S/N 0430 and on. Includes items 2 [3], 5 [3], 10 [3], 12 [1], 13 [1], 14 [3], 15 [3], 16 [3], and 19. Ship S/N 0429 and prior, order KI-128 Upgrade Kit [item 20].)	X	1
5	MS21042L3	Nut	X	10
6	C439-7	Push-Pull Tube Guide Assembly (Incl items 2, 5, 10, and 12 thru 16)	X	1
7	C121-5	Push-Pull Tube Assembly (Ref)		
8	C261-7	Rib (LH, see Figure 53-11	X	1
9	C261-8	Rib (RH, see Figure 53-11)	X	1
10	NAS6603-7	Bolt	X	6
11	MS20470AD4-4	Rivet	X	9
12	C439-8	Retainer	X	2
13	C439-9	Bushing	X	2
14	C439-3	Spacer	X	6
15	C439-4	Roller	X	6
16	C439-5	Pin	X	6
17	NAS1149F0332P	Washer	X	8
18	A130-21	Spacer	X	4
19	B439-4	Plate	X	1
* * *				
20	KI-128	Aft Push-Pull Tube Guide Assembly Upgrade Installation Kit*** (Incl items 1, 4, 5 [4], 17, 18, and 21)	X	1
21	KI-128-1	Template (not shown)	O	1

NOTES * Manual controls.
 ** No longer available. See Figure 67-35, item 41.
 *** Ship S/N 0001 thru 0429.

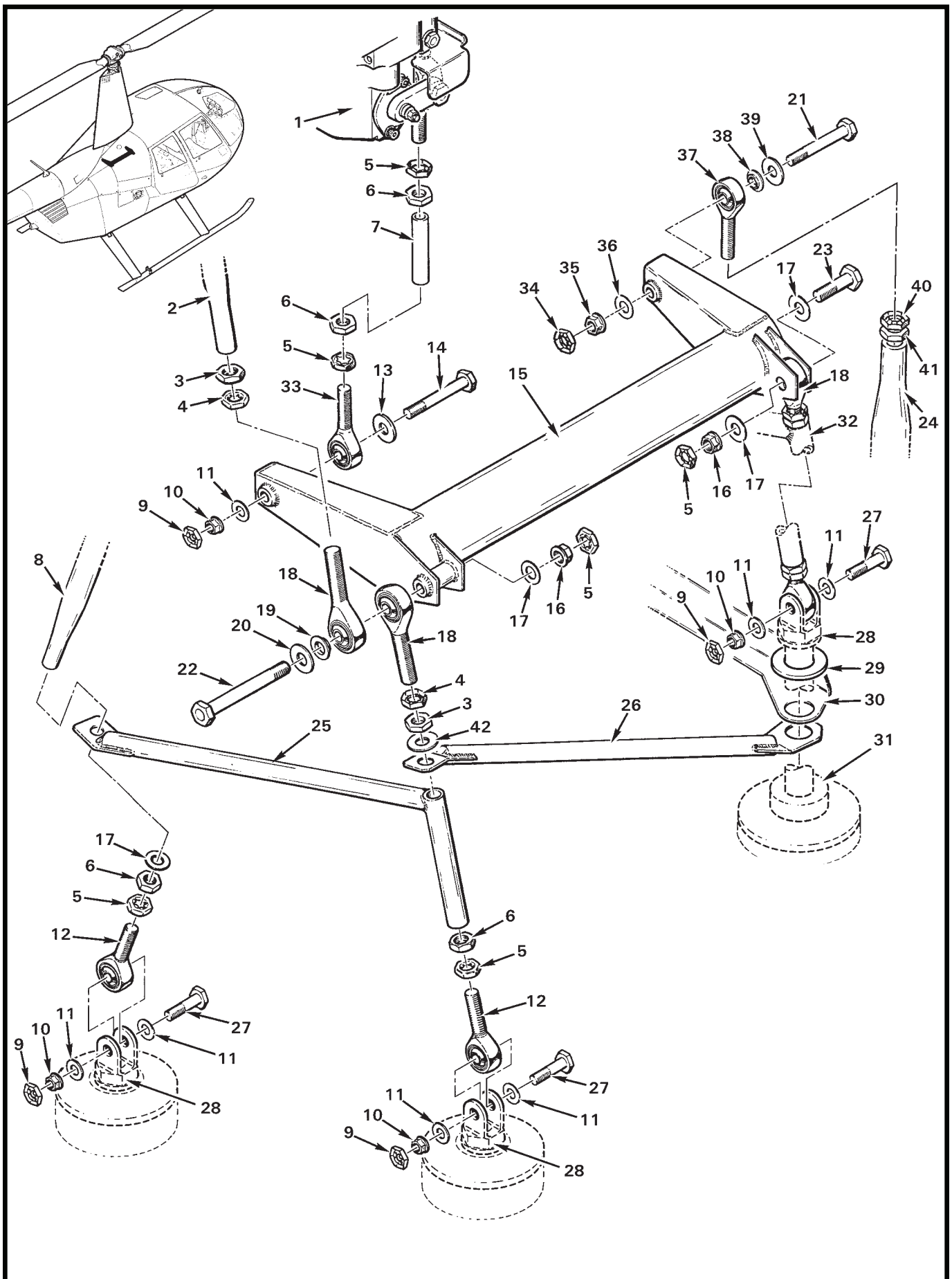

FIGURE AND INDEX NUMBER	PART NUMBER	DESCRIPTION	PARTS AVAIL	QTY PER ASSY
		JACKSHAFT INSTALLATION		
67-53-1	D212-1	Servo Assembly (aft; Ref)		
2	D204-8	Support Assembly – RH (Ref, see Figure 29-3)		
3	AN316-6R	Nut	X	2
4	B330-19	Palnut	X	3
5	B330-16	Palnut	X	6
6	AN316-5R	Nut	X	4
7	C343-8	Tube	X	1
8	D203-1	Support Assembly – LH (Ref, see Figure 29-3)		
9	B330-13	Palnut	X	4
10	D210-4	Nut	X	7
11	NAS1149F0432P	Washer	X	7
12	A101-4	Rod End	X	2
13	A214-3	Washer	X	1
14	NAS6604-21	Bolt	X	1
15	C339-10*	Jackshaft Weldment	X	1
	C339-1**	Jackshaft Weldment	X	1
16	D210-5	Nut	X	3
17	NAS1149F0532P	Washer	X	4
18	D173-1	Rod End	X	4
19	C115-1	Spacer	X	3
20	C141-1	Washer	X	2
21	NAS6604-23*	Bolt	X	1
	NAS6605-23**	Bolt	X	1
22	NAS6605-33	Bolt	X	1
23	NAS6605-8	Bolt	X	1
24	C121-30*	Push-Pull Tube (Ref, see Figure 67-27)		
	C121-3**	Push-Pull Tube Assembly (Ref, see Figure 67-31)		
25	D208-1	Weldment – Aft	X	1
26	C345-5	Weldment	X	1
27	NAS6604-8	Bolt	X	3
28	A650-4	Fitting (Ref, see Figure 67-59)		
29	NAS1149F1063P	Washer	X	1

NOTES * Ship S/N 1001 and subsequent.
 ** Ship S/N 1000 and prior.

Continues

FIGURE AND INDEX NUMBER	PART NUMBER	DESCRIPTION	PARTS AVAIL	QTY PER ASSY
JACKSHAFT INSTALLATION (Cont'd)				
67-53-30	C559-6	Brace (Ref, see Figure 67-57)		
31	C130-21	Spacer (Ref, see Figure 67-59)		
32	D207-1	Weldment (Ref, see Figure 67-57)		
33	B163-2	Rod End	X	1
34	B330-13*	Palnut	X	1
	B330-16**	Palnut	X	1
35	D210-4*	Nut	X	1
	D210-5**	Nut	X	1
36	NAS1149F0432P*	Washer	X	1
	NAS1149F0532P**	Washer	X	1
37	B163-2*	Rod End	X	1
	D173-1**	Rod End	X	1
38	A115-1*	Spacer	X	1
	C115-1**	Spacer	X	1
39	A214-3*	Washer	X	1
	C141-1**	Washer	X	1
40	B330-16*	Palnut	X	1
	B330-19**	Palnut	X	1
41	AN316-5R*	Nut	X	1
	AN316-6R**	Nut	X	1
42	NAS1149F0632P	Washer	X	1

NOTES * Ship S/N 1001 and subsequent.
 ** Ship S/N 1000 and prior.

Intentionally Blank

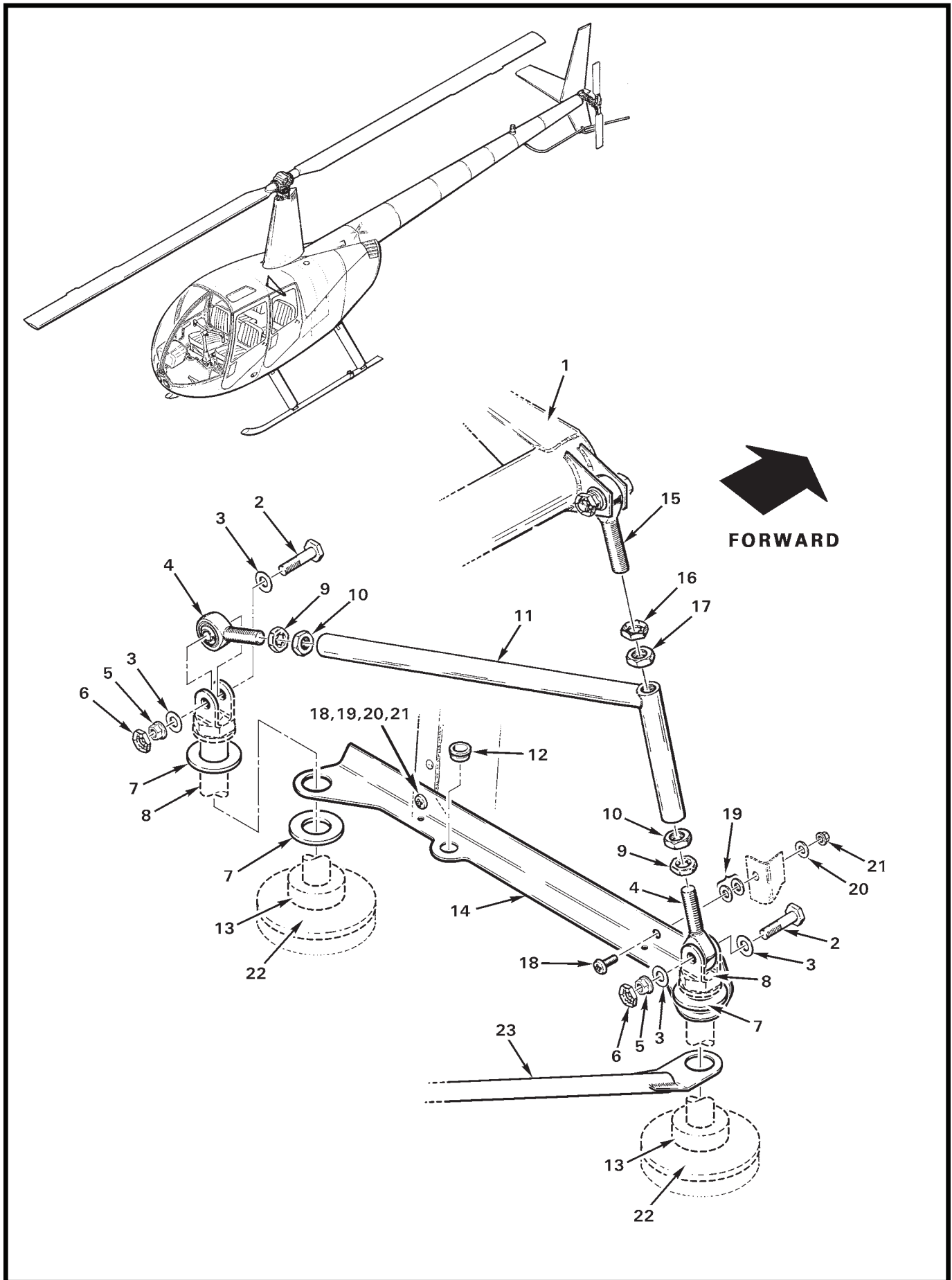

FIGURE AND INDEX NUMBER	PART NUMBER	DESCRIPTION	PARTS AVAIL	QTY PER ASSY
JACKSHAFT SUPPORT WELDMENT INSTALLATION				
67-57-1	C339	Jackshaft Weldment (Ref, see Figure 67-53)		
2	NAS6604-8	Bolt	X	2
3	NAS1149F0432P	Washer	X	4
4	A101-4	Rod End	X	2
5	D210-4	Nut	X	2
6	B330-13	Palnut	X	2
7	NAS1149F1063P	Washer (Ref, see Figure 63-1)		
8	A650-4	Fitting (Ref, see Figure 67-59)		
9	B330-16	Palnut	X	2
10	AN316-5R	Nut	X	2
11	D207-1	Weldment (forward)	X	1
12	2813	Bushing	X	1
13	C130-21	Spacer (Ref)		
14	C559-6	Brace	X	1
15	D173-1	Rod End (Ref, see Figure 67-53)		
16	B330-19	Palnut	X	1
17	AN316-6R	Nut	X	1
18	MS27039C0806	Screw (or MS27039C0807 as required)	X	2
19	NAS1149FN832P	Washer (as required at this location for shimming)	X	A/R
20	NAS1149FN832P	Washer ([1] required at this location)	X	2
21	MS21042L08	Nut	X	2
22	A267-1	Washer (Ref)		
23	C345-5	Weldment (Ref, see Figure 67-53)		

NOTES

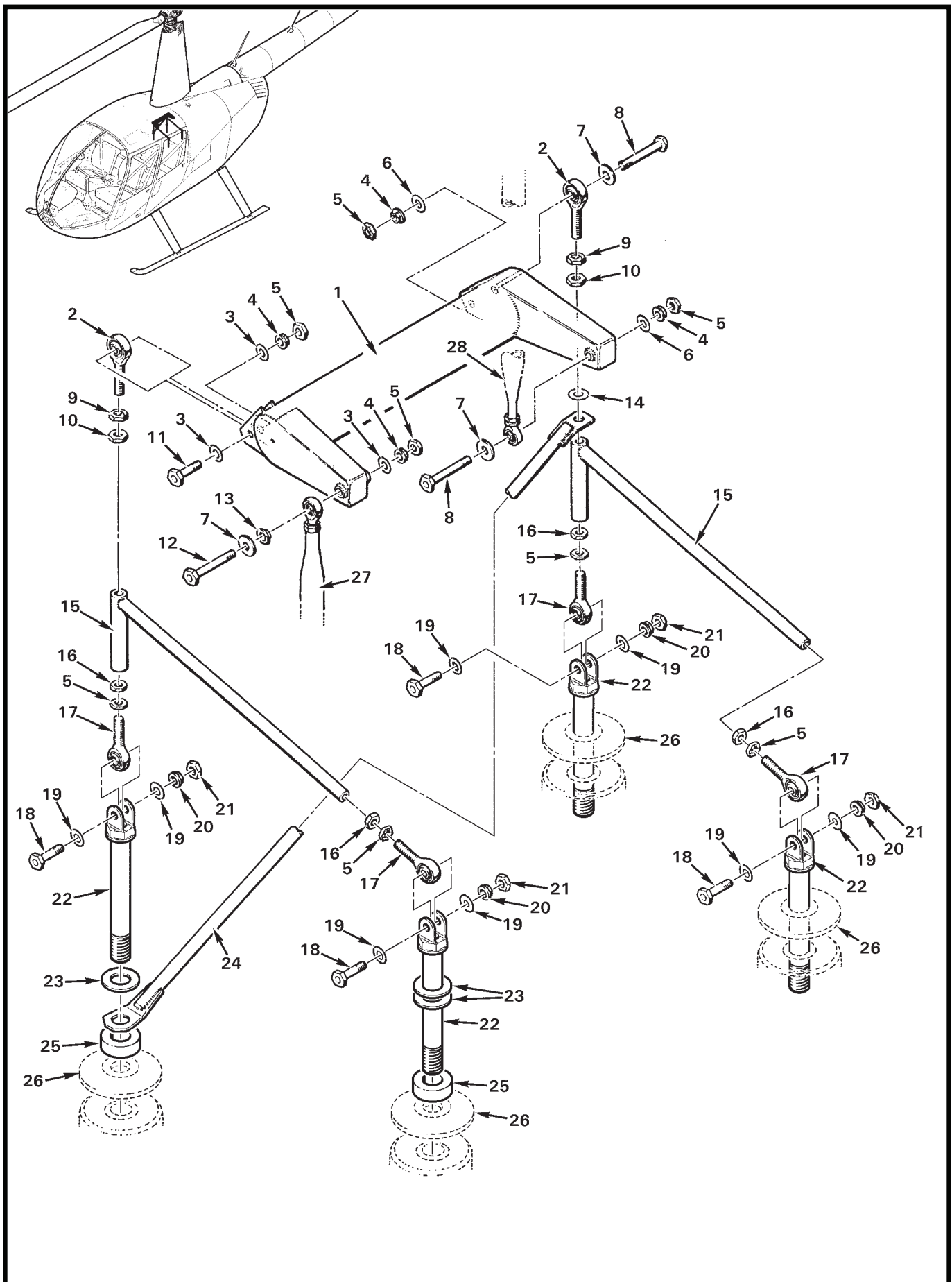

FIGURE AND INDEX NUMBER	PART NUMBER	DESCRIPTION	PARTS AVAIL	QTY PER ASSY
JACKSHAFT INSTALLATION				
67-59-1	C337-1	Jackshaft Assembly	X	1
2	D173-1	Rod End	X	2
3	NAS1149F0532P	Washer	X	3
4	D210-5	Nut	X	4
5	B330-16	Palnut	X	8
6	AN960-516	Washer	X	2
7	C141-1	Washer	X	3
8	NAS6605-25	Bolt	X	2
9	B330-19	Palnut	X	2
10	AN316-6R	Nut	X	2
11	NAS6605-8	Bolt	X	1
12	NAS6605-26	Bolt	X	1
13	C115-1	Spacer	X	1
14	NAS1149F0632P	Washer	X	1
15	C344-1	Tube Weldment	X	2
16	AN316-5R	Nut	X	4
17	A101-4	Rod End	X	4
18	NAS6604-8	Bolt	X	4
19	NAS1149F0432P	Washer	X	8
20	D210-4	Nut	X	4
21	B330-13	Palnut	X	4
22	A650-4*	Fitting (supersedes A650-2)	X	4
23	NAS1149F1063P	Washer	X	3
24	C345-1	Strut Weldment	X	1
25	C130-21	Spacer	X	2
26	A267-1	Washer (Ref)		
27	C121-3	Push-Pull Tube Assembly (Ref)		
28	C121-5	Push-Pull Tube Assembly (Ref)		

NOTES * Refer to Figure 63-1 for nut.

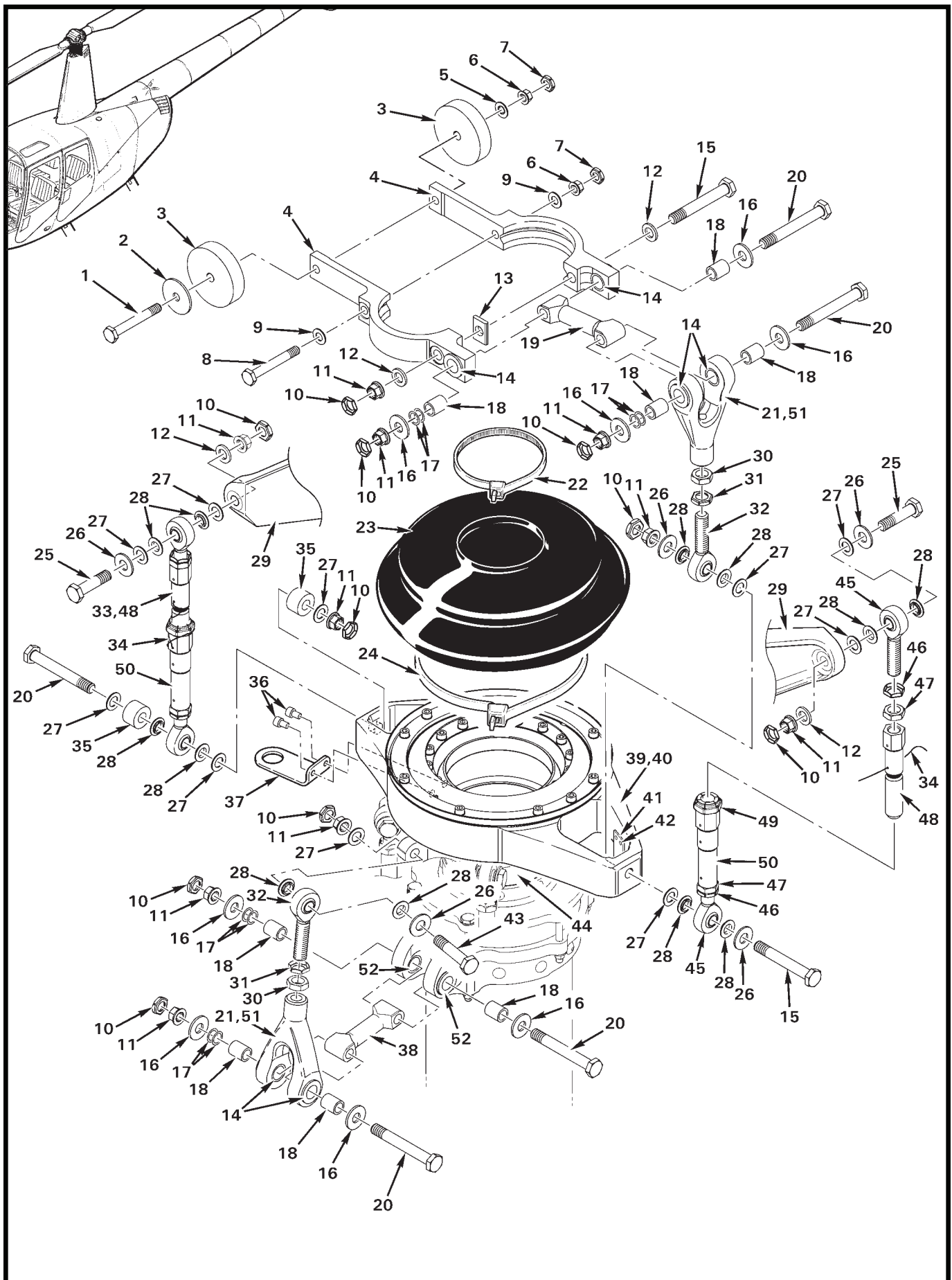

FIGURE AND INDEX NUMBER	PART NUMBER	DESCRIPTION	PARTS AVAIL	QTY PER ASSY
SWASHPLATE INSTALLATION				
67-61-1	NAS6604-24	Bolt (Determine proper bolt length per R44 Maintenance Manual, Section 1.310)	X	1
2	AN970-4	Washer (A/R for balance)	X	A/R
3	A255-1 or A255-2	Counter Weight (1.10 in. O.D.) Counter Weight (1.90 in. O.D.)	X X	A/R A/R
4	C203-5	Yoke Assembly (includes item 13)	X	2
5	NAS1149F0432P	Washer (or NAS1149F0463P as required for correct nut engagement)	X	A/R
6	D210-4	Nut	X	2
7	B330-13	Palnut	X	2
8	NAS6604-24	Bolt	X	1
9	NAS1149F0432P	Washer	X	2
10	B330-16	Palnut	X	13
11	D210-5	Nut	X	13
12	NAS1149F0563P	Washer	X	2
13	A210-1	Key	X	1
14	C648-2	Bearing – Journal	X	1
15	NAS6605-28	Bolt	X	2
16	C141-19	Washer	X	8
17	C117-67 C117-68 C117-69	Shim (thickness = 0.016 in.) Shim (thickness = 0.020 in.) Shim (thickness = 0.025 in.)	X X X	A/R A/R A/R
18	C105-6	Journal	X	8
19	C204-3	Arm (upper 2.87 inches long)	X	1
20	NAS6605-31	Bolt	X	4
21	A205-7	Fork Assembly (includes item 14 [2], install using item 51)	X	2
22	MS3367-7-9	Ty-Rap	X	1
23	C480-1	Boot	X	1
24	MS3367-6-0	Ty-Rap	X	1
25	NAS6605-18	Bolt	X	2
26	C141-1	Washer	X	6
27	NAS1149F0532P	Washer	X	9
28	C115-1	Spacer	X	14
29	C016	Blade Assembly – Main Rotor (Ref)		
30	AN316-6R	Nut	X	2

NOTES

Continues

FIGURE AND INDEX NUMBER	PART NUMBER	DESCRIPTION	PARTS AVAIL	QTY PER ASSY
SWASHPLATE INSTALLATION (Cont'd)				
67-61-31	B330-19	Palnut	X	2
32	D173-3	Rod End	X	2
33	C258-1	Pitch Link Assembly (Incl items 34 thru 49, and 50)	X	2
34	MS20995C32	0.032 in. dia. Safety Wire	X	A/R
35	A255-3	Counter Weight	X	2
36	NAS1352N08-4	Screw	X	2
37	B769-2	Bracket	X	1
38	C204-2	Arm – Lower (2.520 inches long)	X	1
39	C017-6	Swashplate Assembly (Incl items 36, 37,40, 41, 42, 44, and 53)	X	1
	C017-6R	Swashplate Assembly – Overhaul Exchange (Ref)		
40	C199-2	Swashplate Assembly – Upper (Ref)		
41	C769-2	Interrupter	X	1
42	MS20470AD3	Rivet	X	2
43	NAS6605-17	Bolt	X	4
44	F198-1	Swashplate Assembly – Lower (Ref)		
45	D173-3	Rod End	X	1
46	B330-19	Palnut	X	1
47	AN316-6R	Nut	X	1
48	C258-2	Fitting	X	1
49	21FKF-813	Nut	X	1
50	C258-4	Link Assembly (includes C258-3 link and items 45 thru 47)	X	1
51	B270-13	Sealant (to fill cavity in item 21)	X	A/R
52	C648-2	Bearing (Ref)		
53	C647-12	Bearing Set (life-limited component, see MM § 3.100; not shown)	O	1

NOTES

Intentionally Blank

FIGURE AND INDEX NUMBER	PART NUMBER	DESCRIPTION	PARTS AVAIL	QTY PER ASSY
SWASHPLATE INSTALLATION*				
67-65-1	NAS6604-24	Bolt (Determine proper bolt length per R44 Maintenance Manual, § 1.310)	X	1
2	AN970-4	Washer (A/R for balance)	X	A/R
3	A255-1 or A255-2	Counter Weight (1.10 in. O.D.) Counter Weight (1.90 in. O.D.)	X X	A/R A/R
4	C203-5	Yoke Assembly (incl item 13)	X	2
5	NAS1149F0432P	Washer (or NAS1149F0463P as required for correct nut engagement)	X	A/R
6	D210-4	Nut	X	2
7	B330-13	Palnut	X	2
8	NAS6604-24	Bolt	X	1
9	NAS1149F0432P	Washer	X	2
10	B330-16	Palnut	X	13
11	D210-5	Nut	X	13
12	NAS1149F0563P	Washer	X	4
13	A210-1	Key	X	1
14	C648-2	Bearing – Journal	X	1
15	NAS6605-28	Bolt	X	2
16	C141-19	Washer	X	8
17	C117-67 C117-68 C117-69	Shim (thickness = 0.016 in.) Shim (thickness = 0.020 in.) Shim (thickness = 0.025 in.)	X X X	A/R A/R A/R
18	C105-6	Journal	X	8
19	C204-3	Arm – Upper (2.87 inches long)	X	1
20	NAS6605-31	Bolt	X	5
21	A205-7	Fork Assembly (includes item 14 [2], install using item 51) . .	X	2
22	MS3367-7-9	Ty-Rap	X	1
23	C480-1	Boot	X	1
24	MS3367-6-0	Ty-Rap	X	1
25	NAS6605-18	Bolt	X	2
26	C141-1	Washer	X	6
27	NAS1149F0532P	Washer	X	9
28	C115-1	Spacer	X	18
29	C016	Blade Assembly – Main Rotor (Ref)		
30	AN316-6R	Nut	X	2

NOTES * No longer available. Superseded by C017-6 Swashplate Assembly, see Figure 67-61.

Continues

FIGURE AND INDEX NUMBER	PART NUMBER	DESCRIPTION	PARTS AVAIL	QTY PER ASSY
SWASHPLATE INSTALLATION (Cont'd)				
67-65-31	B330-19	Palnut	X	2
32	D173-2	Rod End	X	2
33	C258-1	Pitch Link Assembly (Incl items 34, 45 thru 47, 49, and 50)	X	2
34	MS20995C32	0.032 in. dia. Safety Wire	X	A/R
35	A255-3	Counter Weight	X	2
36	MS20995C20	0.020 in. dia. Safety Wire	X	A/R
37	AN503-8-4	Screw	X	2
38	B769-1	Bracket	X	1
39	C204-2	Arm – Lower (2.00 inches long)	X	1
40	C199-1	Swashplate Assembly – Upper	O	1
41	C769-2	Interrupter	X	1
42	MS20470AD3	Rivet	X	2
43	NAS6605-20	Bolt	X	4
44	C198-1	Swashplate Assembly – Lower	O	1
45	D173-3	Rod End	X	1
46	B330-19	Palnut	X	1
47	AN316-6R	Nut	X	1
48	C258-2	Fitting	X	1
49	21FKF-813	Nut	X	1
50	C258-4	Link Assembly (includes C258-3 link and items 45 thru 47) . .	X	1
51	B270-13	Sealant (to fill cavity in item 21)	X	A/R
52	C648-2	Bearing (Ref)		
53	C017-4*	Swashplate Assembly (Ref, includes item 54)		
54	C647-12	Bearing Set (life-limited component, see MM § 3.100; not shown)	O	1

NOTES * No longer available.

Intentionally Blank

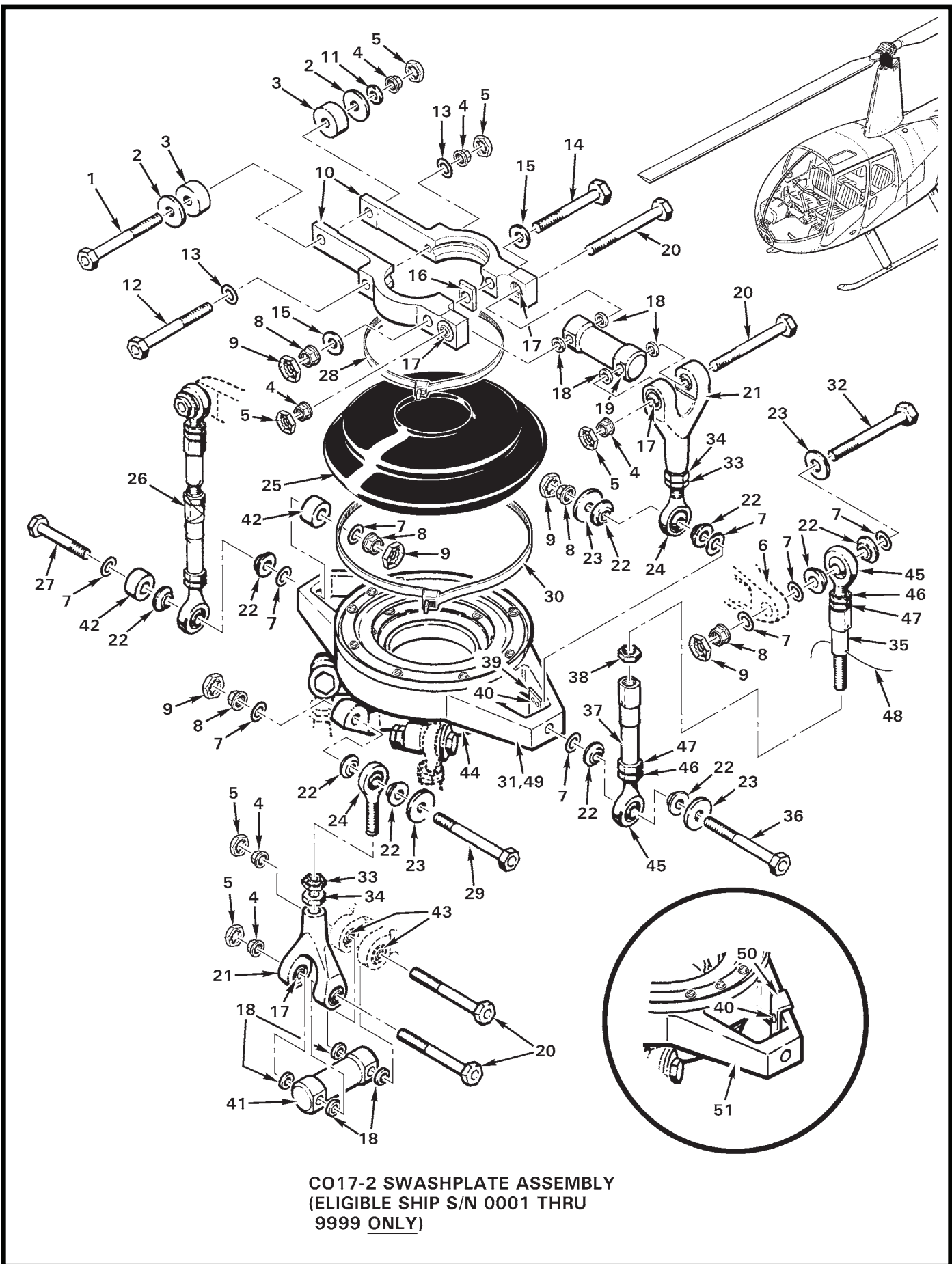

FIGURE AND INDEX NUMBER	PART NUMBER	DESCRIPTION	PARTS AVAIL	QTY PER ASSY
SWASHPLATE INSTALLATION*				
67-69-1	NAS6604-24	Bolt (Determine proper bolt length per R44 Maintenance Manual, Section 1.310)	X	1
2	AN970-4	Washer (A/R for balance)	X	A/R
3	A255-1 or	Counter Weight (1.10 in. O.D.)	X	A/R
	A255-2	Counter Weight (1.90 in. O.D.)	X	A/R
4	D210-4	Nut	X	6
5	B330-13	Palnut	X	6
6	C016	Blade Assembly – Main Rotor (Ref)		
7	NAS1149F0532P	Washer	X	17
8	D210-5	Nut	X	9
9	B330-16	Palnut	X	9
10	C203-2	Yoke Assembly (Incl item 17)	X	2
11	NAS1149F0463P	Washer (or NAS1149F0432P as required for correct engagement)	X	A/R
12	NAS6604-24	Bolt	X	1
13	NAS1149F0432P	Washer	X	2
14	NAS6605-28	Bolt	X	1
15	NAS1149F0563P	Washer	X	2
16	A210-1	Key	X	1
17	B115-1	Bearing	X	1
18	A130-47	Spacer	X	8
19	C204-1	Arm (upper, 2.850 inches long)	X	1
20	NAS1304-28	Bolt (do not substitute with NAS6604-28)	X	4
21	A205-5	Fork Assembly (Incl item 17, [2 each])	X	2
22	C115-1	Spacer	X	18
23	C141-1	Washer	X	8
24	D173-2	Rod End	X	2
25	C480-1	Boot	X	1
26	C258-1	Pitch Link Assembly (Incl items 37, 38, and 45 thru 47)	X	2
27	NAS6605-32	Bolt	X	1
28	MS3367-7-9	Ty-Rap	X	1
29	NAS6605-19	Bolt	X	4

NOTES * Ship S/N 0001 thru 9999. No longer available. Superseded by C017-6 Swashplate Assembly, see Figure 67-61.

Continues

FIGURE AND INDEX NUMBER	PART NUMBER	DESCRIPTION	PARTS AVAIL	QTY PER ASSY
SWASHPLATE INSTALLATION* (Cont'd)				
67-69-30	MS3367-6-0	Ty-Rap	X	1
31	C017-2	Swashplate Assembly (Ref)		
32	NAS6605-17	Bolt	X	2
33	B330-19	Palnut	X	2
34	AN316-6R	Nut	X	2
35	C258-2	Fitting	X	2
36	NAS6605-28	Bolt	X	1
37	C258-4	Link Assembly (Includes C258-3 link and items 45 thru 47) . .	X	1
38	21FKF-813	Nut	X	1
39	C769-2	Interrupter	X	1
40	MS20470AD3	Rivet	X	2
41	A204-1	Arm (lower, 2.350 inches long)	X	1
42	A255-3	Counter Weight (0.70 in. O.D.)	X	2
43	B115-1	Bearing (Ref)		
44	C198-1	Swashplate Assembly – Lower (Ref)		
45	D173-3	Rod End	X	1
46	B330-19	Palnut	X	1
47	AN316-6R	Nut	X	1
48	MS20995C32	0.032 in. dia. Safety Wire	X	A/R
49	C199-1	Swashplate – Upper (Ref, Revision "G")		
50	C769-1	Interrupter (use only with item 51)	X	1
51	C199-1	Swashplate – Upper (Ref, Revision "F" and Prior)		

NOTES * Ship S/N 0001 thru 9999. No longer available. Superseded by C017-6 Swashplate Assembly, see Figure 67-61.

Intentionally Blank

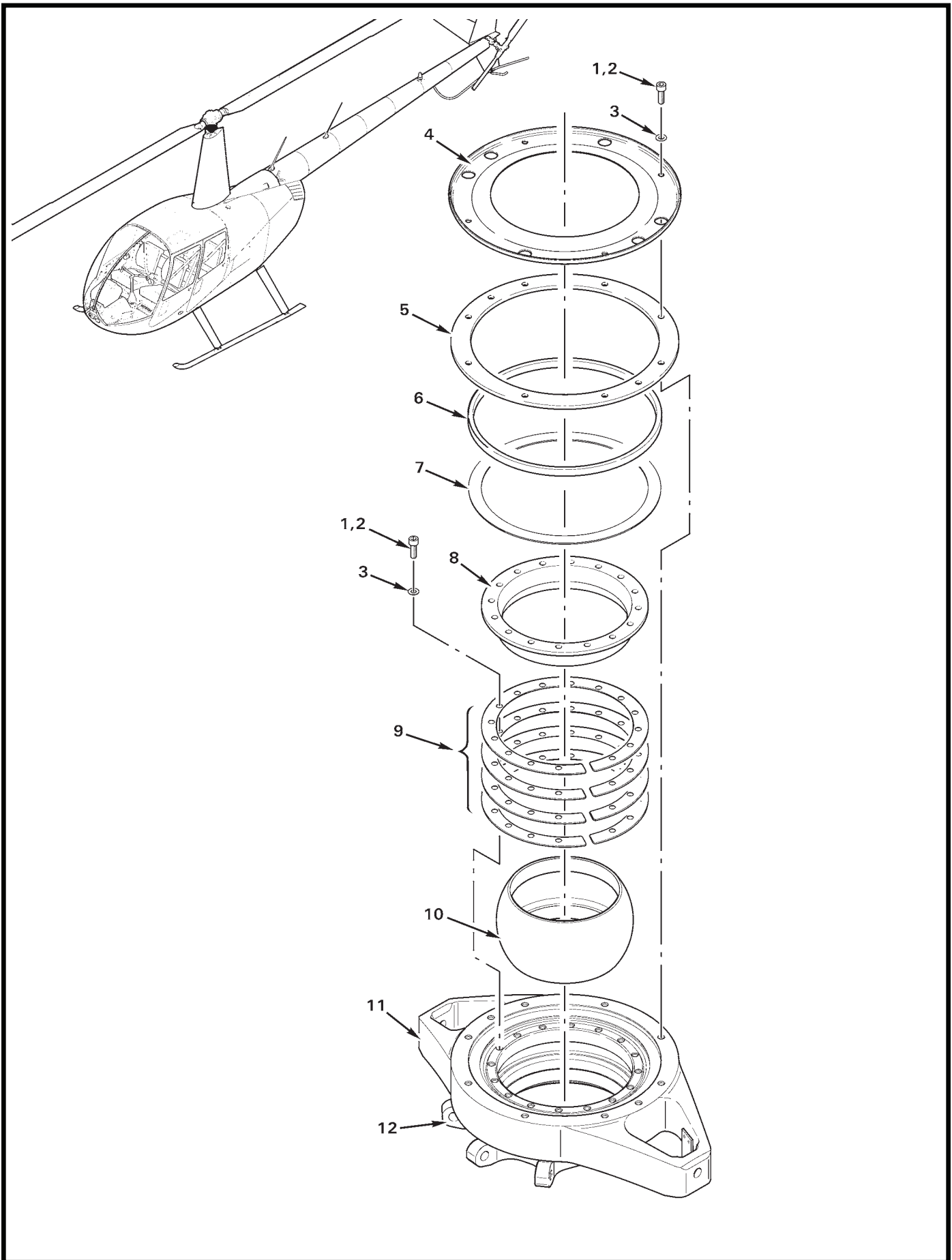

FIGURE AND INDEX NUMBER	PART NUMBER	DESCRIPTION	PARTS AVAIL	QTY PER ASSY
SWASHPLATE BALL INSTALLATION*				
67-73-1	NAS1352N08-8	Screw (install using item 2)	X	26
2	A257-9	Anti-Seize	X	A/R
3	NAS620-8L	Washer	X	26
4	C206-2	Retainer	X	1
5	C200-3	Retainer	X	1
6	C219-3	Spacer	X	1
7	C217-1	Seal	X	1
8	C205-1	Sleeve Assembly	X	1
9	C197-1 *	Spacer (thickness = 0.016 in.)	X	A/R
	C197-2 *	Spacer (thickness = 0.020 in.)	X	A/R
	C197-3 *	Spacer (thickness = 0.025 in.)	X	A/R
	C197-4 *	Spacer (thickness = 0.032 in.)	X	A/R
	C197-5 *	Spacer (thickness = 0.040 in.)	X	A/R
	C197-6 *	Spacer (thickness = 0.050 in.)	X	A/R
10	C201-1	Ball Assembly	X	1
11	C199-2	Swashplate Assembly - Upper (Ref)		
12	F198-1	Swashplate Assembly - Lower (Ref)		

NOTES * C017-6 revision "AD" and higher.

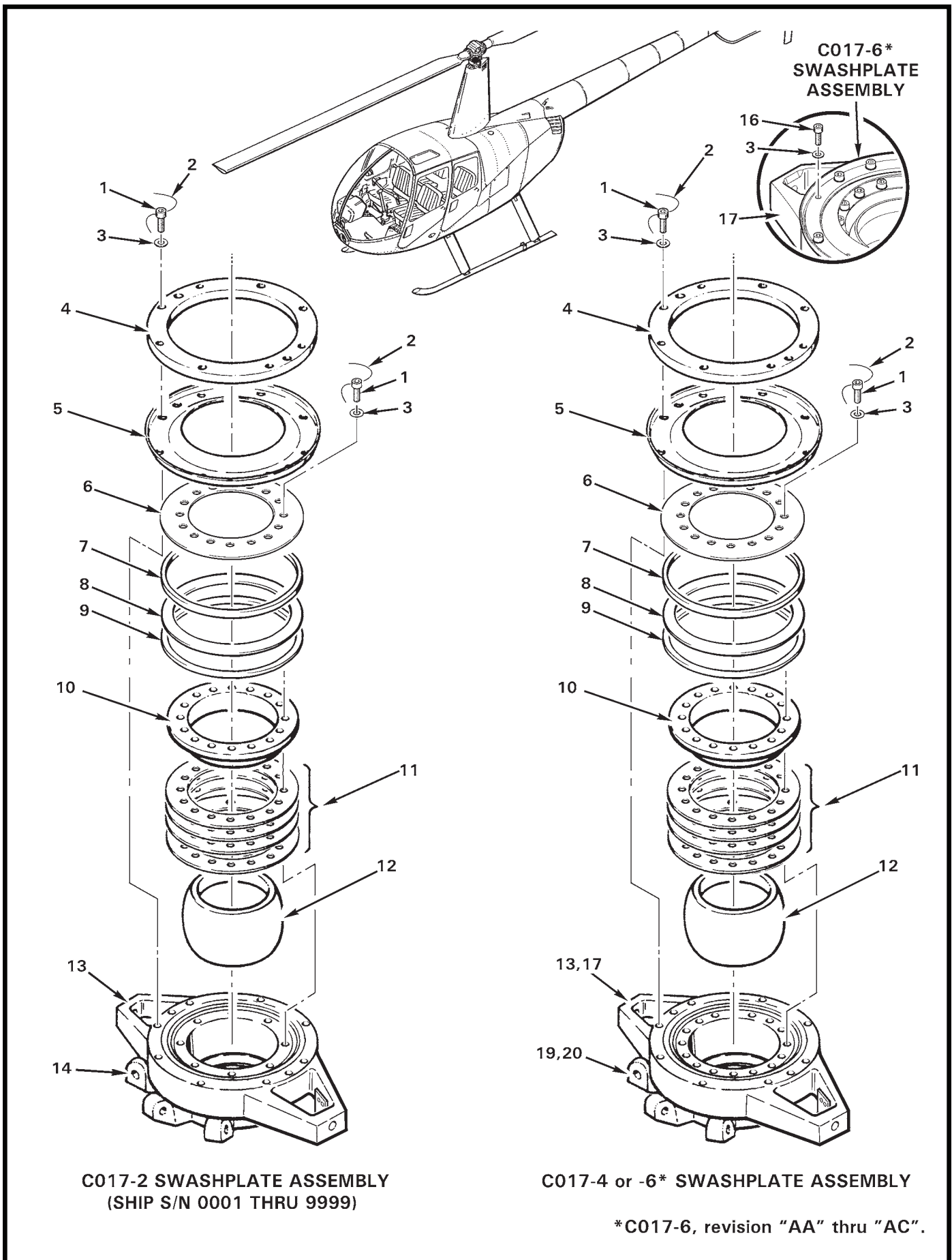

FIGURE AND INDEX NUMBER	PART NUMBER	DESCRIPTION	PARTS AVAIL	QTY PER ASSY
SWASHPLATE BALL INSTALLATION				
67-75-1	NAS1352N08H8	Screw ([26] used with item 18)	X	18
2	MS20995C20	0.020 in. dia. Safety Wire (use with item 1)	X	A/R
3	NAS620-8L	Washer	X	A/R
4	C200-1	Retainer	X	1
5	C206-1	Retainer	X	1
6	C218-1	Shield	X	1
7	C219-2	Spacer	X	1
8	C218-2	Shield	X	1
9	C219-1	Spacer	X	1
10	C205-1 *	Sleeve Assembly	X	1
11	C197-1 *	Spacer (thickness = 0.016 in.)	X	A/R
	C197-2 *	Spacer (thickness = 0.020 in.)	X	A/R
	C197-3 *	Spacer (thickness = 0.025 in.)	X	A/R
	C197-4 *	Spacer (thickness = 0.032 in.)	X	A/R
	C197-5 *	Spacer (thickness = 0.040 in.)	X	A/R
	C197-6 *	Spacer (thickness = 0.050 in.)	X	A/R
12	C201-1	Ball Assembly	X	1
13	C199-1	Swashplate - Upper (Ref)		
14	C198-1	Swashplate - Lower (Ref)		
15	C017-2	Swashplate Sub-Assembly (Ref, no longer available; ship S/N 0001 thru 9999. Includes items 13 and 14. See also Figure 67-61.)		
16	NAS1352N08-8	Screw (use only with items 17 and 20; item 2 not required). . .	X	26
17	C199-2	Swashplate - Upper (Ref)		
18	C017-4	Swashplate Sub-Assembly (Ref; ship S/N 10001 and higher. Includes items 13 and 19. See also Figure 67-61.)		
	C017-6 **	Swashplate Sub-Assembly (Ref; ship S/N 10001 and higher. Includes items 17 and 20. See also Figure 67-61.)		
19	C198-2	Swashplate - Lower (Ref, serialized, installed in C017-4 swashplate assembly.)		
20	F198-1	Swashplate - Lower (Ref, <u>not</u> serialized, installed in C017-6 swashplate assembly.)		
21	A257-9	Anti-Seize	X	A/R

NOTES * Revision "B" or later required with item 16.
 ** C017-6, revision "AA thru "AC".

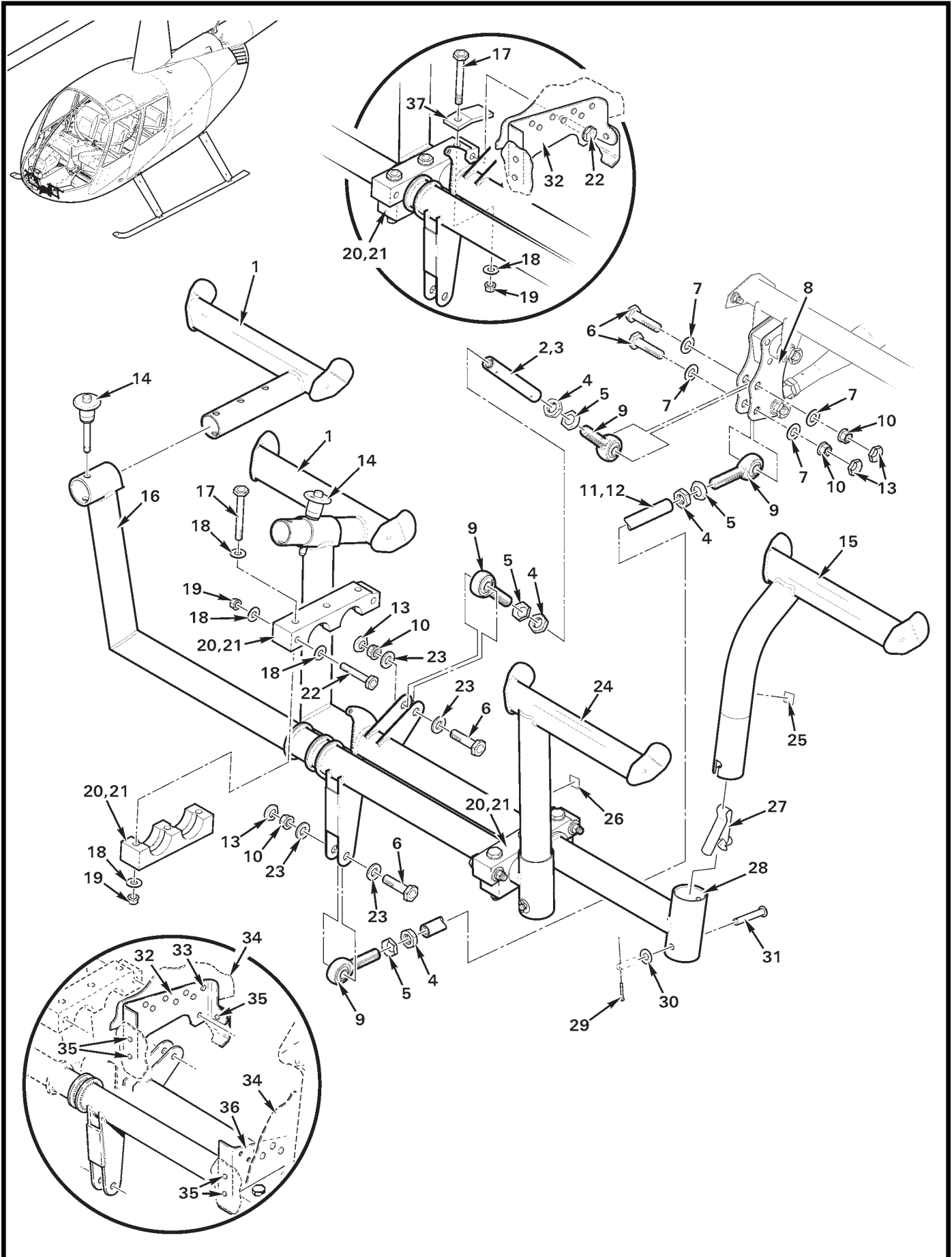

FIGURE AND INDEX NUMBER	PART NUMBER	DESCRIPTION	PARTS AVAIL	QTY PER ASSY
		TAIL ROTOR CONTROLS – PEDALS INSTALLATION*		
67-77-1	F755-1	Pedal – Left/Right Foot, Pilot	X	2
2	C343-9	Tube Assembly (Incl items 3 thru 5, and 9)	X	1
3	C343-10	Tube (Ref)	O	1
4	AN316-5R	Nut	X	2
5	B330-16	Palnut	X	2
6	NAS6604-9	Bolt	X	4
7	NAS1149FN432P	Washer	X	4
8	C317-5	Bellcrank Assembly (Ref; see Figure 67-85)	X	1
9	A101-4	Rod End	X	4
10	D210-4	Nut	X	4
11	C343-11	Tube Assembly (Incl items 4, 5, 9 and 12)	X	1
12	C343-12	Tube (Ref)	O	1
13	B330-13	Palnut	X	4
14	B232-1	Pin (Locking; button handle)	X	2
15	F755-2	Pedal Assembly – Left Foot Co-Pilot (Incl item 27)	X	1
16	D755-2	Pedal Assembly – Right Foot (Incl items 24, and 29 thru 31)	X	1
17	NAS6603-20	Bolt	X	6
18	NAS1149F0332P	Washer	X	20
19	MS21042L3	Nut	X	10
20	A318-1-2	Bearing Block Set	X	2
21	A257-1	Grease (for bearing block grooves)	X	A/R
22	NAS6603-13	Bolt	X	4
23	NAS1149F0463P	Washer	X	4
24	F755-3	Pedal Assembly – Right Foot Co-Pilot (Incl item 27)	X	1
25	A654-50	Decal – “L” (for earlier R44s)	X	1
26	A654-51	Decal – “R” (for earlier R44s)	X	1
27	A795-4	Pin	X	1
28	D755-1	Pedal Assembly – Left Feet (Incl items 15, and 29 thru 31) . .	X	1
29	MS24665-132	Cotter Pin	X	2
30	NAS1149D0316J	Washer (or AN960PD10L)	X	2
31	MS20392-2C33	Flathead Pin	X	2

NOTES * Ship S/N 0761 and subsequent.

Continues

FIGURE AND INDEX NUMBER	PART NUMBER	DESCRIPTION	PARTS AVAIL	QTY PER ASSY
TAIL ROTOR CONTROLS – PEDALS INSTALLATION* (Cont'd)				
67-77-32	A359-2	Support – RH	X	1
33	MS20470AD4	Rivet	X	18
34	C033	Lower Console Assembly (Ref)		
35	MS20470AD3	Rivet	X	6
36	A359-1	Support – LH	X	1
37	B831-1**	Tab	X	1

NOTES * Ship S/N 0761 and subsequent.
 ** Earlier R44s. Refer to R44 Service Bulletin SB-63.

Intentionally Blank

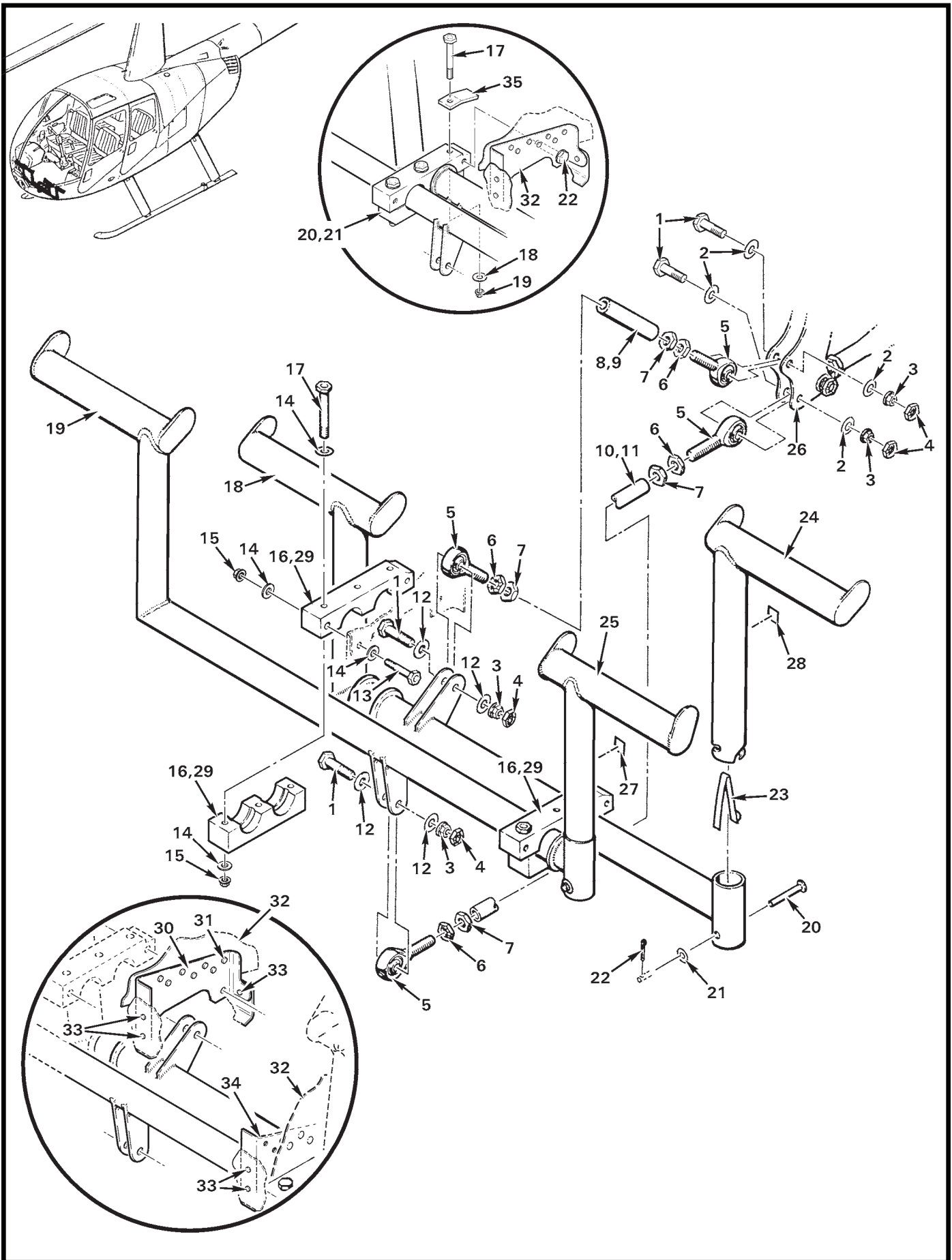

FIGURE AND INDEX NUMBER	PART NUMBER	DESCRIPTION	PARTS AVAIL	QTY PER ASSY
TAIL ROTOR CONTROLS – PEDALS INSTALLATION*				
67-81-1	NAS6604-9	Bolt	X	4
2	NAS1149F0432P	Washer	X	4
3	D210-4	Nut	X	4
4	B330-13	Palnut	X	4
5	A101-4	Rod End	X	4
6	B330-16	Palnut	X	4
7	AN316-5R	Nut	X	4
8	C343-4	Tube (Ref)	O	1
9	C343-3	Push-Pull Tube Assembly (Incl items 5 thru 8)	X	1
10	C343-6	Tube	O	1
11	C343-5	Push-Pull Tube Assembly (Incl items 5 thru 7, and 10)	X	1
12	NAS1149F0463P	Washer	X	4
13	NAS6603-13	Bolt	X	4
14	NAS1149F0332P	Washer	X	20
15	MS21042L3	Nut	X	10
16	A318-1-2	Bearing Block Set	X	2
17	NAS6603-20	Bolt	X	6
18	A755-5	Pedal Assembly – Left Foot (Incl items 21 thru 23)	X	1
19	A755-6	Pedal Assembly – Right Foot (Incl items 21 thru 23)	X	1
20	MS20392-2C33	Flat-Head Pin	X	2
21	NAS1149D0316J	Washer (or AN960PD10L)	X	2
22	MS24665-132	Cotter Pin	X	2
23	A795-4	Pin Assembly	X	2
24	A755-3	Pedal Assembly – Co-Pilot, Left Foot (Incl item 23)	X	1
25	A755-4	Pedal Assembly – Co-Pilot, Right Foot (Incl item 23)	X	1
26	C317-2	Bellcrank Assembly (Ref; see Figure 67-85)	X	1
27	A654-51	Decal – “R” (for earlier R44s)	X	1
28	A654-50	Decal – “L” (for earlier R44s)	X	1
29	A257-1	Grease (for bearing block grooves)	X	A/R
30	A359-2	Support – RH	X	1
31	MS20470AD4	Rivet	X	18

NOTES * Ship S/N 0760 and prior.

Continues

FIGURE AND INDEX NUMBER	PART NUMBER	DESCRIPTION	PARTS AVAIL	QTY PER ASSY
TAIL ROTOR CONTROLS – PEDALS INSTALLATION* (Cont'd)				
67-81-32	C033	Lower Console Assembly (Ref)		
33	MS20470AD3	Rivet	X	6
34	A359-1	Support – LH	X	1
35	B831-1**	Tab	X	1

NOTES * Ship S/N 0760 and prior.
 ** Earlier R44s. Refer to R44 Service Bulletin SB-63.

Intentionally Blank

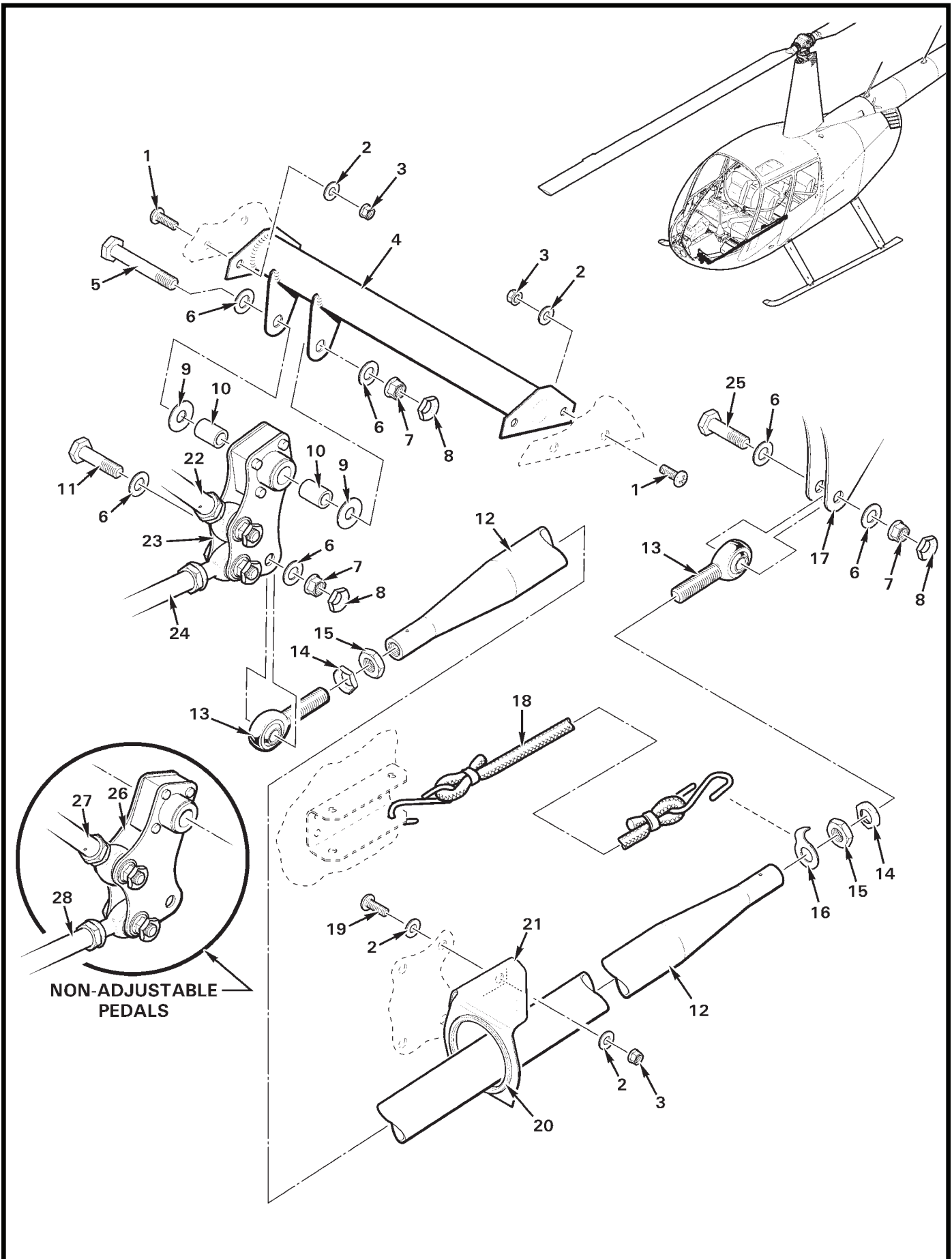

FIGURE AND INDEX NUMBER	PART NUMBER	DESCRIPTION	PARTS AVAIL	QTY PER ASSY
TAIL ROTOR CONTROLS – C317 BELLCRANK				
67-85-1	MS27039C0807	Screw	X	4
2	NAS1149FN832P	Washer	X	12
3	MS21042L08	Nut	X	8
4	C349-1	Support Assembly	X	1
5	NAS6604-19	Bolt	X	1
6	NAS1149F0432P	Washer	X	6
7	D210-4	Nut	X	3
8	B330-13	Palnut	X	3
9	A141-3	Washer	X	2
10	A105-3	Journal	X	2
11	NAS6604-9	Bolt	X	1
12	C121-9	Push-Pull Tube Assembly (Incl items 13 thru 16)	X	1
13	A101-4	Rod End	X	2
14	B330-16	Palnut	X	2
15	AN316-5R	Nut	X	2
16	A697-6	Tab	X	1
17	C317-1	Bellcrank Assembly (Ref)		
18	A918-1	Elastic Cord Assembly (6 lb)	X	1
	A918-2	Elastic Cord Assembly (8 lb)	X	1
	A918-3	Elastic Cord Assembly (10 lb)	X	1
	A918-4	Elastic Cord Assembly (12 lb)	X	1
	A918-5	Elastic Cord Assembly (14 lb)	X	1
	A918-6	Elastic Cord Assembly (16 lb)	X	1
	A918-7	Elastic Cord Assembly (18 lb)	X	1
	A918-8	Elastic Cord Assembly (20 lb)	X	1
19	MS27039C0806	Screw	X	4
20	NAS557-22A	Grommet	X	1
21	C346-1	Restraint	X	1
22	C343-9	Push-Pull Tube Assembly (Ref, see Figure 67-81)		
23	C317-5	Bellcrank Assembly (Ship S/N 0761 and higher. Use only with items 22 and 24.)	X	1
24	C343-11	Push-Pull Tube Assembly (Ref, see Figure 67-81)		

NOTES

Continues

FIGURE AND INDEX NUMBER	PART NUMBER	DESCRIPTION	PARTS AVAIL	QTY PER ASSY
TAIL ROTOR CONTROLS – C317 BELLCRANK (Cont'd)				
67-85-25	NAS6604-8	Bolt	X	1
26	C317-2	Bellcrank Assembly (Ship S/N 0001 thru 0760. Use only with items 27 and 28.)	X	1
27	C343-3	Push-Pull Tube Assembly (Ref, see Figure 67-81)		
28	C343-5	Push-Pull Tube Assembly (Ref, see Figure 67-81)		
NOTES				

Intentionally Blank

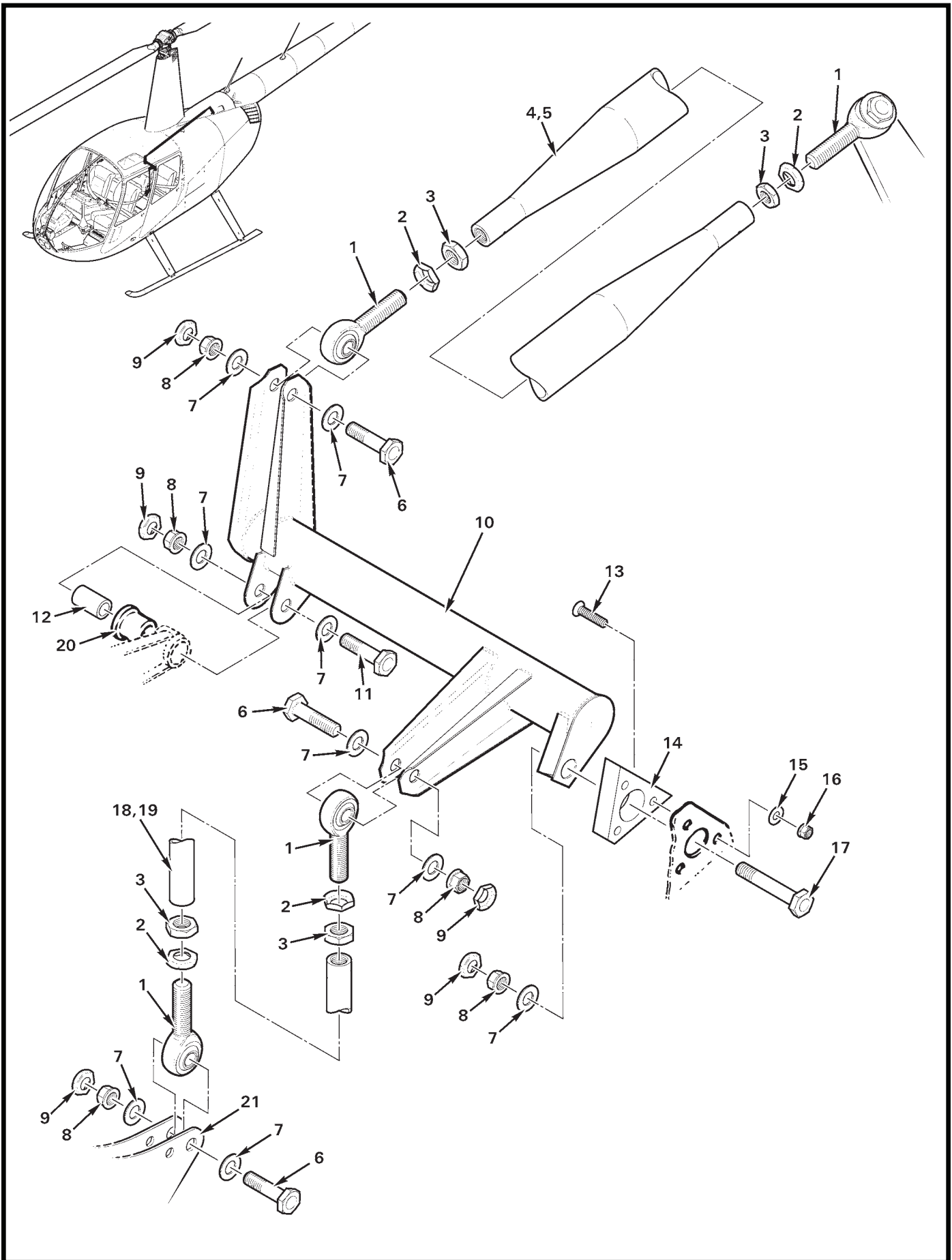

FIGURE AND INDEX NUMBER	PART NUMBER	DESCRIPTION	PARTS AVAIL	QTY PER ASSY
TAIL ROTOR CONTROLS – C316 BELLCRANK				
67-89-1	A101-4	Rod End	X	4
2	B330-16	Palnut	X	4
3	AN316-5R	Nut	X	4
4	—	Tube (Ref)		
5	C121-15	Push-Pull Tube Assembly (Incl items 1 thru 4)	X	1
6	NAS6604-8	Bolt	X	3
7	NAS1149F0432P	Washer	X	9
8	D210-4	Nut	X	5
9	B330-13	Palnut	X	5
10	C316-1	Bellcrank Assembly	X	1
11	NAS6604-11	Bolt	X	1
12	A105-6	Journal	X	1
13	MS24694-S8	Screw	X	3
14	C329-1	Bearing Assembly	X	1
15	NAS1149FN816P	Washer	X	3
16	MS21042L08	Nut	X	3
17	NAS1304-17	Bolt	X	1
18	C343-2	Tube	O	1
19	C343-1	Push-Pull Tube Assembly (Incl items 1 thru 3, and 18)	X	1
20	A139-1	Bearing	X	1
21	C317-1	Bellcrank Assembly (Ref)		

NOTES

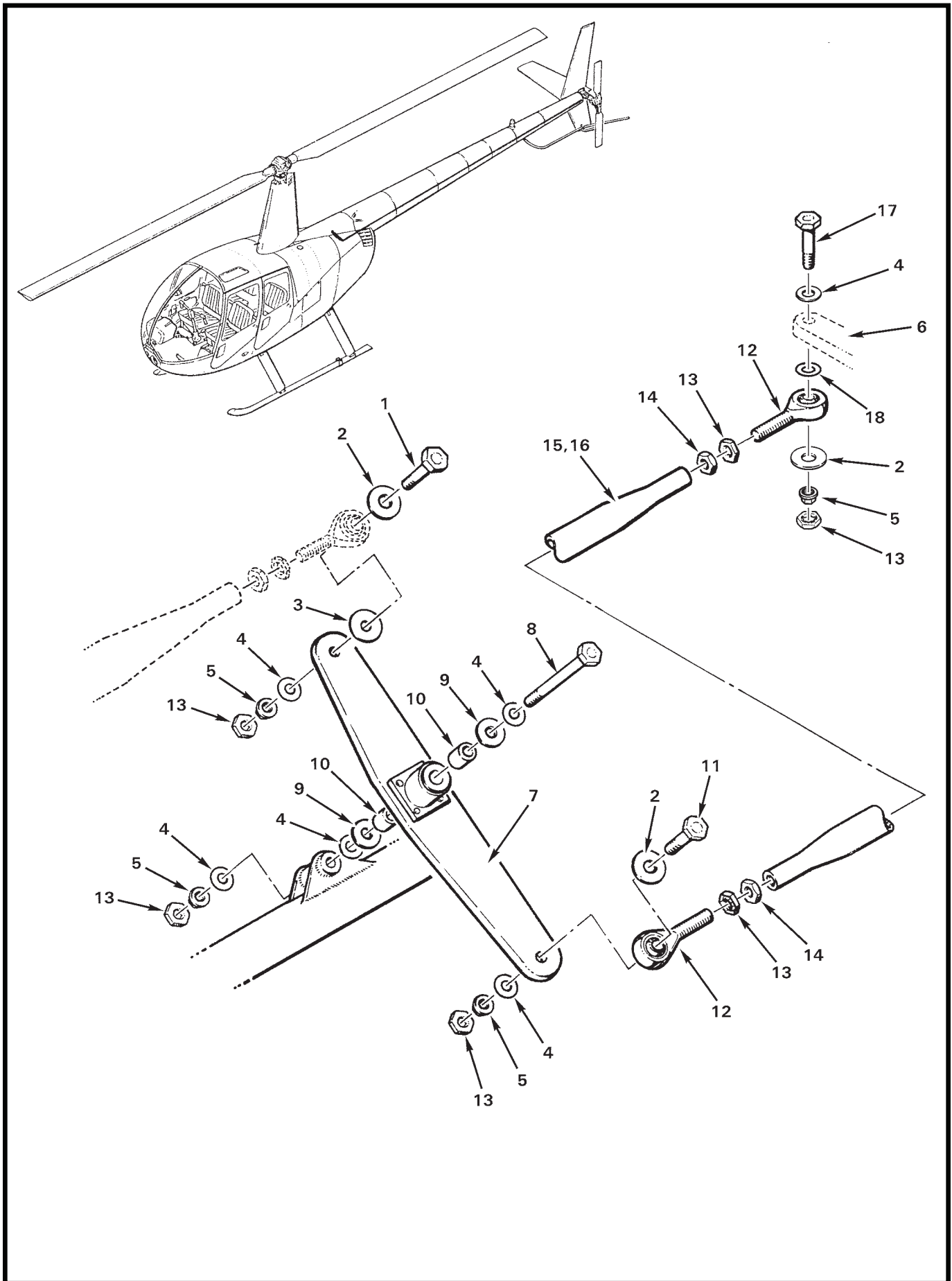

FIGURE AND INDEX NUMBER	PART NUMBER	DESCRIPTION	PARTS AVAIL	QTY PER ASSY
TAIL ROTOR CONTROLS – C331 BELLCRANK				
67-91-1	NAS6604-11	Bolt	X	1
2	A214-3	Washer	X	3
3	MS20002-4	Washer	X	1
4	NAS1149F0432P	Washer	X	6
5	D210-4	Nut	X	4
6	A120-3	Bellcrank (Ref)		
7	A331-4	Bellcrank Assembly	X	1
8	NAS1304-35	Bolt	X	1
9	A141-3	Washer	X	2
10	A105-3	Journal	X	2
11	NAS6604-9	Bolt	X	1
12	A127-4	Rod End	X	2
13	B330-13	Palnut	X	6
14	AN316-4R	Nut	X	2
15	—	Tube (Ref)		
16	C121-17	Push-Pull Tube Assembly (Incl items 12 thru 15)	X	1
17	NAS6604-10	Bolt (or NAS6604-11)	X	1
18	NAS1149F0432P	Washer (or NAS1149F0463P as required for minimum 0.050 inch clearance between push-pull tube and aft tailcone bulkhead casting)	X	A/R

NOTES

Intentionally Blank

CHAPTER 71**POWERPLANT**

<i>Figure</i>	<i>Title</i>	<i>Page</i>
71-1	Forward Engine Mounts	71.0
71-3	Aft Engine Support Assembly	71.2
71-5	O-540 Powerplant Components	71.4
71-9	IO-540 Powerplant Components	71.8
71-13	Air Induction System	71.12
71-17	Air Induction System	71.16
71-21	Exhaust Muffler Assembly	71.20
71-25	Exhaust Muffler Shield Assembly	71.24
71-27	Scroll Assembly	71.26
71-29	Scroll Assembly	71.28
71-31	Left Side Cooling Panels	71.30
71-35	Left Side Cooling Panels	71.34
71-37	Left Side Cooling Panels	71.36
71-41	Right Side Cooling Panels	71.40
71-45	Right Side Cooling Panels	71.44
71-49	Main Rotor Gearbox Cooling Hoses	71.48
71-49B	Alternator Installation (24V)	71.49A
71-51	Alternator and Starter Installation	71.50
71-55	Starter Installation	71.54
71-59	130-Amp 28V Alternator Installation	71.58
71-63	Alternator Control Unit Installation	71.62
71-65	D174 Fanwheel Assembly	71.65

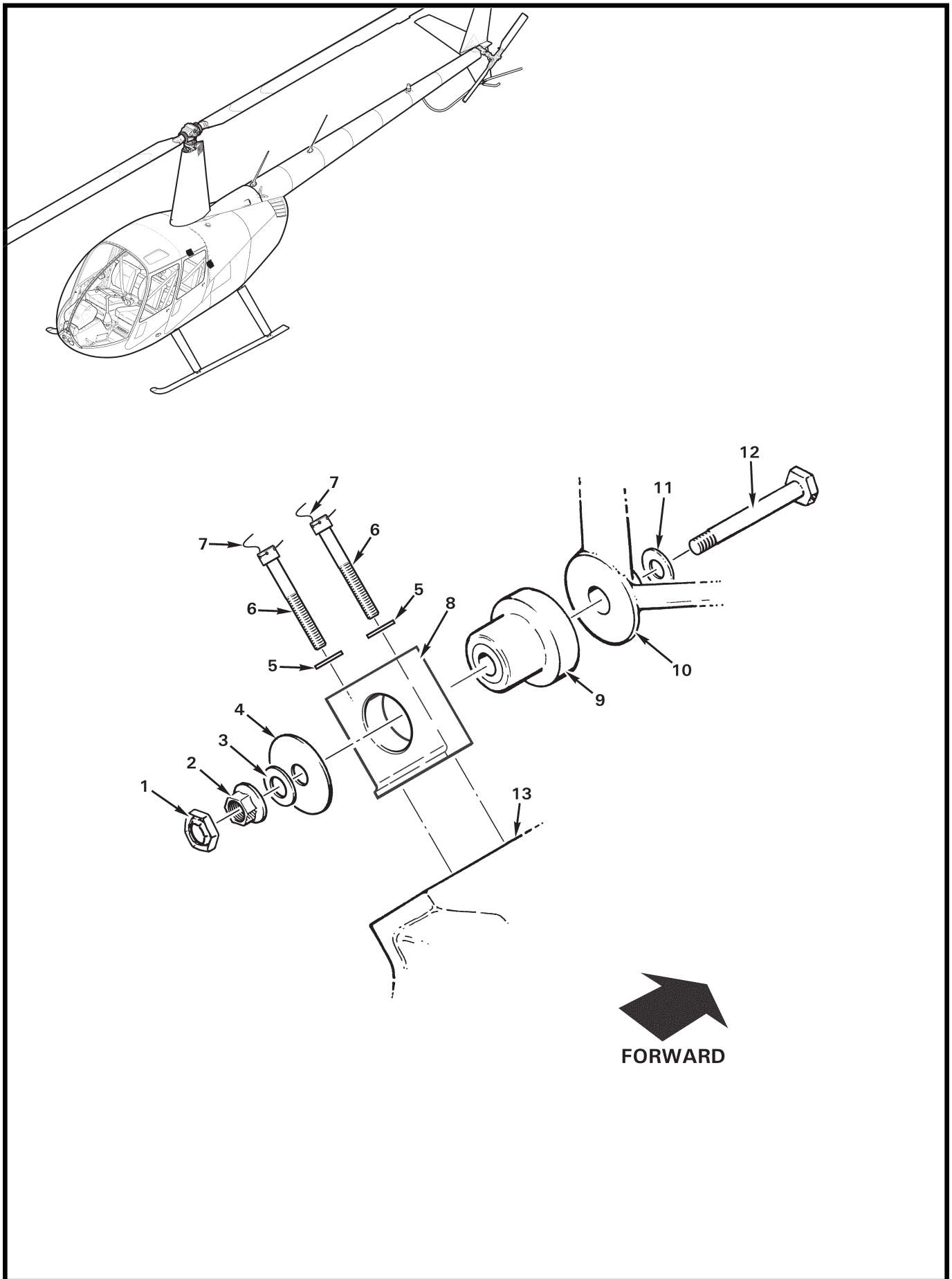

FIGURE AND INDEX NUMBER	PART NUMBER	DESCRIPTION	PARTS AVAIL	QTY PER ASSY
FORWARD ENGINE MOUNTS				
71-1-1	B330-24	Palnut	X	2
2	D210-8	Nut	X	2
3	NAS1149F0832P	Washer	X	2
4	C141-9	Washer	X	2
5	NAS1149F0632P	Washer	X	4
6	NAS1352-6H48P	Screw	X	4
7	MS20995C32	0.032 in. dia. Safety Wire	X	A/R
8	C593-3	Engine Mount Assembly (Incl item 9)	X	2
9	C653-2	Mount	X	2
10	C046	Lower Frame Assembly (Ref)		
11	MS20002C8	Washer	X	2
12	NAS6608-39	Bolt (or AN8-31A)	X	2
13	—	Engine (Ref)		
NOTES				

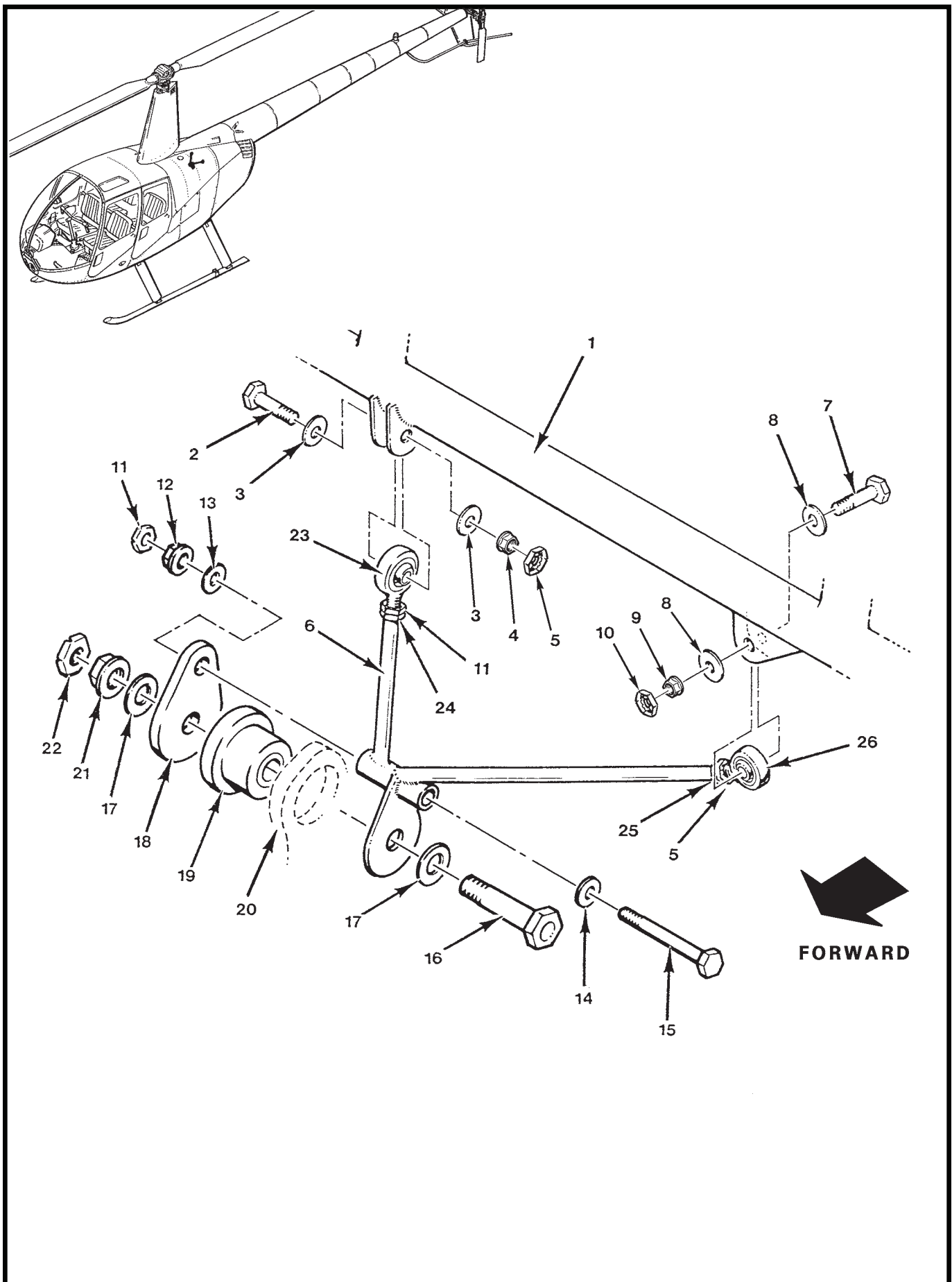

FIGURE AND INDEX NUMBER	PART NUMBER	DESCRIPTION	PARTS AVAIL	QTY PER ASSY
AFT ENGINE SUPPORT ASSEMBLY				
71-3-1	C020-1	Upper Frame Assembly (Ref)		
2	NAS6605-9	Bolt	X	1
3	NAS1149F0532P	Washer	X	2
4	D210-5	Nut	X	1
5	B330-16	Palnut	X	1
6	C174-1	Support	X	1
7	NAS6604-8	Bolt	X	1
8	NAS1149F0432P	Washer	X	2
9	D210-4	Nut	X	1
10	B330-13	Palnut	X	1
11	B330-19	Palnut	X	2
12	D210-6	Nut	X	1
13	NAS1149F0632P	Washer	X	1
14	A141-23	Washer	X	1
15	NAS6606-30	Bolt (or AN6-23A)	X	1
16	NAS6608-20	Bolt (or AN8-20A)	X	1
17	NAS1149F0832P	Washer	X	2
18	C592-2	Link	X	1
19	C653-1	Mount	X	1
20	C592-3	Engine Mount (Ref, includes item 19. See also Figure 71-5 and 71-9.)		
21	D210-8	Nut	X	1
22	B330-24	Palnut	X	1
23	D173-2	Rod End	X	1
24	AN316-6R	Nut	X	1
25	AN316-5R	Nut	X	1
26	A101-4	Rod End	X	1
NOTES				

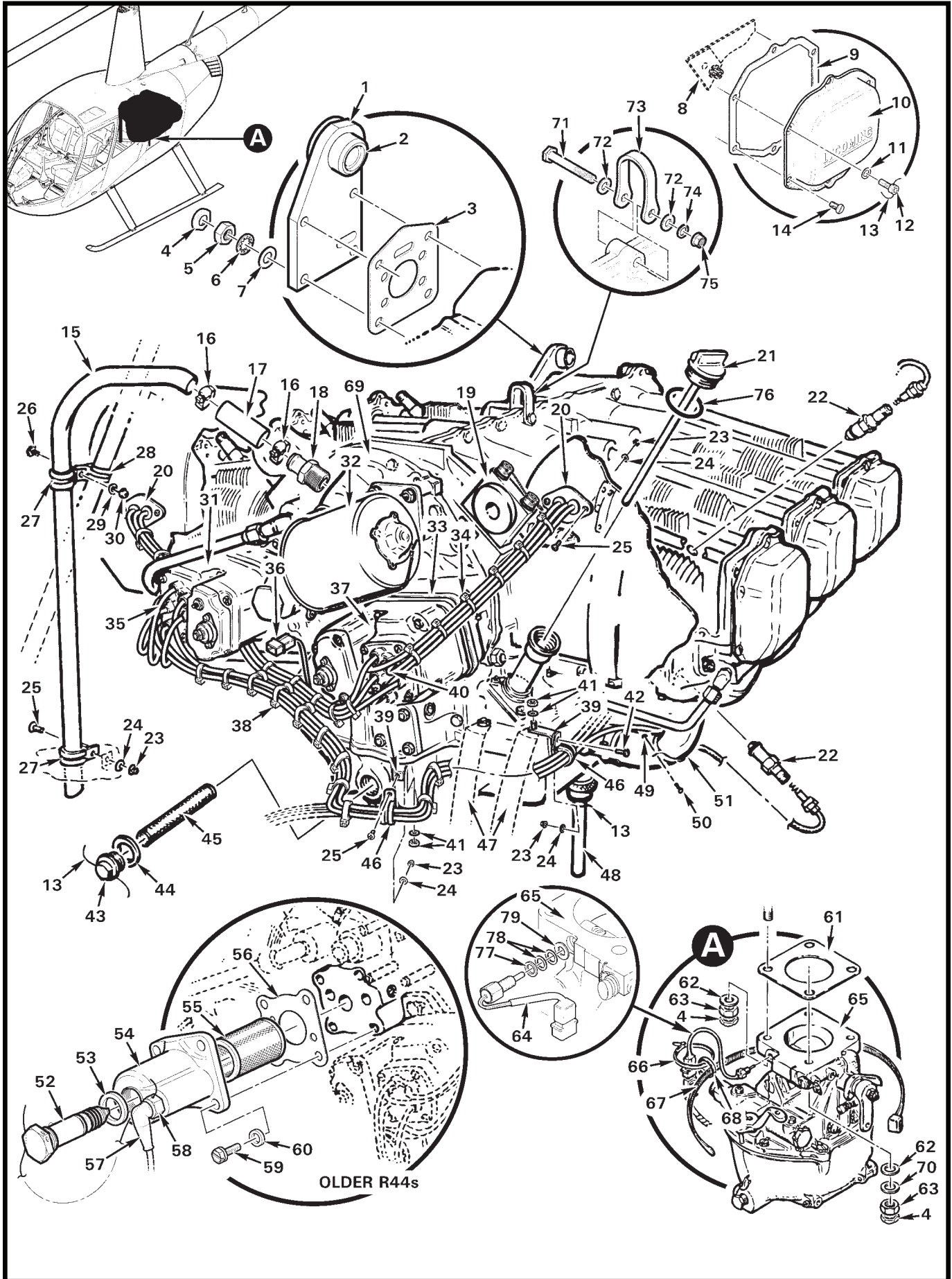

FIGURE AND INDEX NUMBER	PART NUMBER	DESCRIPTION	PARTS AVAIL	QTY PER ASSY
O-540 POWERPLANT COMPONENTS*				
71-5-1	C592-3	Engine Mount Assembly (Incl item 2)	X	1
2	C653-1	Mount (install using A257-8 lubricant)	X	1
3	72053**	Gasket	X	1
4	B330-15	Palnut	X	8
5	STD-1410**	Nut	X	4
6	STD-475**	Washer (internal teeth)	X	4
7	STD-35**	Washer	X	4
8	A305-7	Panel Assembly (Ref)		
9	06B26669**	Gasket (or RG-75906-SP)	X	6
10	61247**	Cover – Rocker Box	X	6
11	NAS1149F0432P	Washer	X	22
12	NAS1352-4H10P	Screw	X	22
13	MS20995C32	0.032 in. dia. Safety Wire	X	A/R
14	STD-1925**	Screw	X	24
15	C727-2	Breather Tube (0.75 in. dia.)	X	1
	C727-1	Breather Tube (1.00 in. dia.; Ref. No longer available, not shown. To replace, order C727-2 tube, A729-31 tube, LW-18575** Nipple and [2] MS21919WDG12 clamps.)		
16	B277-12	Clamp	X	2
17	A729-31	Tube	X	1
18	LW-18575**	Nipple (0.75 in. dia. hose to 0.825 in. dia.)	X	1
19	C593-3	Engine Mount Assembly (Ref, see Figure 71-1)		
20	LW-M-2376**	Harness Plate	X	2
21	LW-16783-17P**	Dip Stick (9-quarts marking)	X	1
22	UREM38E	Spark Plug (or UREM40E, Unison part no.; Ref Lycoming SI 1042)	X	12
	REM38E	Spark Plug (or REM40E, Champion part no.; Ref Lycoming SI 1042)	X	12
23	MS21042L08	Nut	X	7
24	NAS1149FN816P	Washer	X	7
25	MS27039C0806	Screw	X	6
26	AN3-3A	Bolt	X	1
27	MS21919WDG14	Clamp	X	2
28	MS21919WDG12	Clamp	X	1
29	NAS1149F0332P	Washer	X	1
30	MS21042L3	Nut	X	1

NOTES * Ship S/N 0001 thru 9999.
 ** Lycoming part no.

Continues

FIGURE AND INDEX NUMBER	PART NUMBER	DESCRIPTION	PARTS AVAIL	QTY PER ASSY
O-540 POWERPLANT COMPONENTS* (Cont'd)				
71-5-31	10-600616-3*	Magneto (retard; TCM type S6LSC-200)	X	1
	R7567	BL-600616-3* Magneto, retard, overhauled	X	1
32	B123-1 / -2	Oil Filter (Ref, see Figure 79-9)		
33	MS3367-6-0	Ty-Rap (large, black; around magneto)	X	1
34	MS3367-5-9	Ty-Rap (small, around item 33 and wires)	X	2
35	M2463**	Ignition Harness (for retard magneto part no. 10-600616-3*)	X	1
36	B263-12	Housing	X	1
	B263-1	Pin	X	2
37	10-600646-201*	Magneto (tachometer; TCM type S6LSC-204T; Ref)		
	R8265	10-600646-201* Magneto, tachometer, with tachometer connector pins, housing, and heat shrink	X	1
38	MS3367-4-9	Ty-Rap (around ignition wires)	X	A/R
39	C357-1	Clip (one each side and front)	X	3
40	M2464**	Ignition Harness (for tachometer magneto part no. 10-600646-201*)	X	1
41	—	Existing Engine Hardware (Ref)		
42	MS27039C0807	Screw	X	2
43	LW-12545***	Plug	X	1
44	06E19769-1.00***	Gasket	X	1
45	70484***	Screen (oil suction)	X	1
46	MS21919WDG9	Clamp (engine front and right side)	X	2
	MS21919WDG10	Clamp (engine left side, not shown)	X	1
47	A212-2	Ground Strap (Ref, see Figure 96-79)		
48	B367-1	Drain Valve – Oil	X	1
49	MS21044N06	Nut	O	6
50	STD-553***	Screw	X	6
51	LW-18959-175-25***	Clamp	X	6
	B444-3	Clamp	X	6
52	53E22144***	Thermostatic Oil Cooler Bypass Valve	X	1
53	76510***	Gasket – Valve Assembly	X	1
54	69510*	Housing	X	1
55	62817*	Screen Assembly – Oil	X	1
56	61173*	Gasket	X	1
57	MS25171-1S	Nipple	X	1

NOTES * Continental Motors part no.
 ** Slick part no.
 *** Lycoming part no.

Continues

FIGURE AND INDEX NUMBER	PART NUMBER	DESCRIPTION	PARTS AVAIL	QTY PER ASSY
O-540 POWERPLANT COMPONENTS* (Cont'd)				
71-5-58	A760-1	Oil Temperature Sender (Ref; single, see also Figure 96-49)		
	A760-3	Oil Temperature Sender (Ref; dual, see also Figure 96-49)		
59	STD-1856*	Screw (supplied with engine)	X	4
60	STD-8*	Washer	X	4
61	66224*	Gasket	X	1
62	STD-35*	Washer	X	4
63	STD-1410*	Nut	X	4
64	A058-10**	Carb Air Temp Probe (Incl items 77 and 78)	X	1
65	AV10-6035-11	Carburetor (alternate part no. 61C26050*)	X	1
66	MS3367-5-9	Ty-Rap (around connector)	X	1
67	MS3367-6-0	Ty-Rap (around carburetor)	X	1
68	MS3367-4-9	Ty-Rap (around item 66)	X	1
69	C145-1	Engine Assembly (Ref, O-540-F1B5)		
70	NAS1149F0532P	Washer (may be installed at forward left position as required)	X	1
71	LW-25-1.75*	Bolt	X	1
72	NAS1149F0463P	Washer	X	2
73	B200-4	Lug	X	1
74	STD-160*	Lockwasher	X	1
75	—	Nut	O	1
76	74068*	O-Ring – Oil Level Gauge Plug	X	1
77	—	Spacer (thick)	O	1
78	—	Spacer (thin)	O	A/R
79	NAS620-416L	Washer	X	A/R

NOTES * Lycoming part no.
 ** Proper probe position set at RHC, reuse spacer and washer stack up when reinstalling.

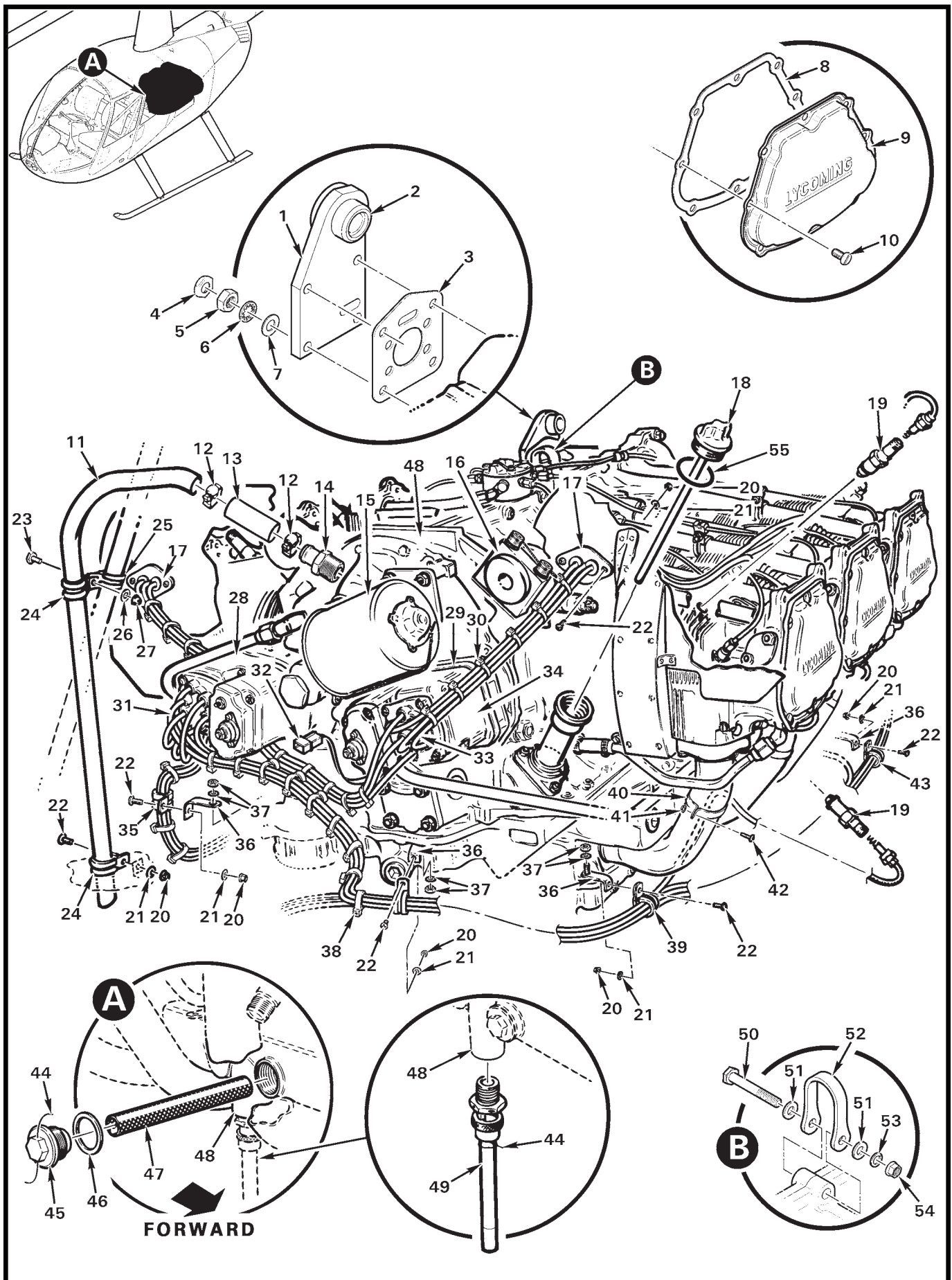

FIGURE AND INDEX NUMBER	PART NUMBER	DESCRIPTION	PARTS AVAIL	QTY PER ASSY
IO-540 POWERPLANT COMPONENTS*				
71-9-1	C592-3	Engine Mount Assembly (Incl item 2)	X	1
2	C653-1	Mount (install using A257-8 lubricant)	X	1
3	72053**	Gasket	X	1
4	B330-15	Palnut	X	4
5	STD-1410**	Nut	X	4
6	STD-475**	Washer (internal teeth)	X	4
7	STD-35**	Washer	X	4
8	RG-67193	Gasket	X	6
9	68795**	Cover Assembly – Rocker Box	X	6
10	STD-1925**	Screw	X	48
11	C727-2	Breather Tube (0.75 in. dia.)	X	1
	C727-1	Breather Tube (Ref; 1.00 in. dia. No longer available, not shown. To replace, order C727-2 tube, A729-31 tube, LW-18575** nipple and [2] MS21919WDG12 clamps.)		
12	B277-12	Clamp	X	2
13	A729-31	Tube (use with C727-2 tube)	X	1
	A729-10	Tube (use with C727-1 tube)	X	1
14	LW-18575**	Nipple	X	1
15	B123-1 / -2	Oil Filter (Ref, see Figure 79-9)		
16	C593-3	Engine Mount Assembly (Ref, see Figure 71-1)		
17	LW-M-2376**	Harness Plate	X	2
18	LW-16783-30P**	Dipstick (9 quarts marking)	X	1
19	UREM38E***	Spark Plug (or UREM40E***)	X	12
20	MS21042L08	Nut	X	11
21	NAS1149FN816P	Washer	X	11
22	MS27039C0806	Screw	X	11
23	AN3-3A	Bolt	X	1
24	MS21919WDG12	Clamp (use with C727-2 tube)	X	2
	MS21919WDG16	Clamp (use with C727-1 tube)	X	2
25	MS21919WDG14	Clamp	X	1
26	NAS1149FO332P	Washer	X	1
27	MS21042L3	Nut	X	1

NOTES * Ship S/N 10001 and subsequent.
 ** Lycoming part no.
 *** Unison part no.

Continues

FIGURE AND INDEX NUMBER	PART NUMBER	DESCRIPTION	PARTS AVAIL	QTY PER ASSY
IO-540 POWERPLANT COMPONENTS (Cont'd)				
71-9-28	10-600616-9*	Magneto (retard; TCM type S6LSC-200)	X	1
29	MS3367-6-0	Ty-Rap (large, black; around magneto)	X	1
30	MS3367-5-9	Ty-Rap (small, around item 29 and wires)	X	2
31	M2463**	Ignition Harness (for retard magneto part no. 10-600616-9*) . .	X	1
32	B263-12	Housing	X	1
	B263-1	Pin	X	2
33	M2464**	Ignition Harness (for tachometer magneto part no. 10-600646-201**)	X	1
34	10-600646-201*	Magneto (tachometer; TCM type S6LSC-204T; Ref)		
	R8265	10-600646-201* Magneto (tachometer, with tachometer connector pins, housing and heat shrink)	X	1
35	MS21919WDG7	Clamp	X	1
36	C357-1	Clip	X	6
37	—	Existing Engine Hardware (Ref)		
38	MS3367-4-9	Ty-Rap (around ignition wires)	X	A/R
39	MS21919WDG12	Clamp (engine right side and front)	X	2
	MS21919WDG6	Clamp (engine left side, not shown)	X	1
40	B444-2 or -3	Clamp	X	6
	LW-18959-163-25***	Clamp	X	6
41	AN365-632A	Nut (supplied with engine)	O	6
42	STD-533***	Screw	O	6
43	MS21919WDG9	Clamp (engine right side)	X	1
	MS21919WDG3	Clamp (engine left side, not shown)	X	1
44	MS20995C32	0.032 in. dia. Safety Wire	X	A/R
45	LW-12545***	Plug	X	1
46	06E19769-1.00***	Gasket	X	1
47	60422***	Screen (oil suction)	X	1
48	C145-2	Engine Assembly (Ref, IO-540-AE1A5)		
49	B367-1	Drain Valve (oil)	X	1
50	LW-25-1.75***	Bolt	O	1
51	NAS1149F0463P	Washer	X	2
52	B200-4	Lug	X	1

NOTES * Continental Motors part no.
 ** Slick part no.
 *** Lycoming part no.

Continues

FIGURE AND INDEX NUMBER	PART NUMBER	DESCRIPTION	PARTS AVAIL	QTY PER ASSY
IO-540 POWERPLANT COMPONENTS (Cont'd)				
71-9-53	STD-160*	Lockwasher	O	1
54	—	Nut	O	1

NOTES * Lycoming part no.

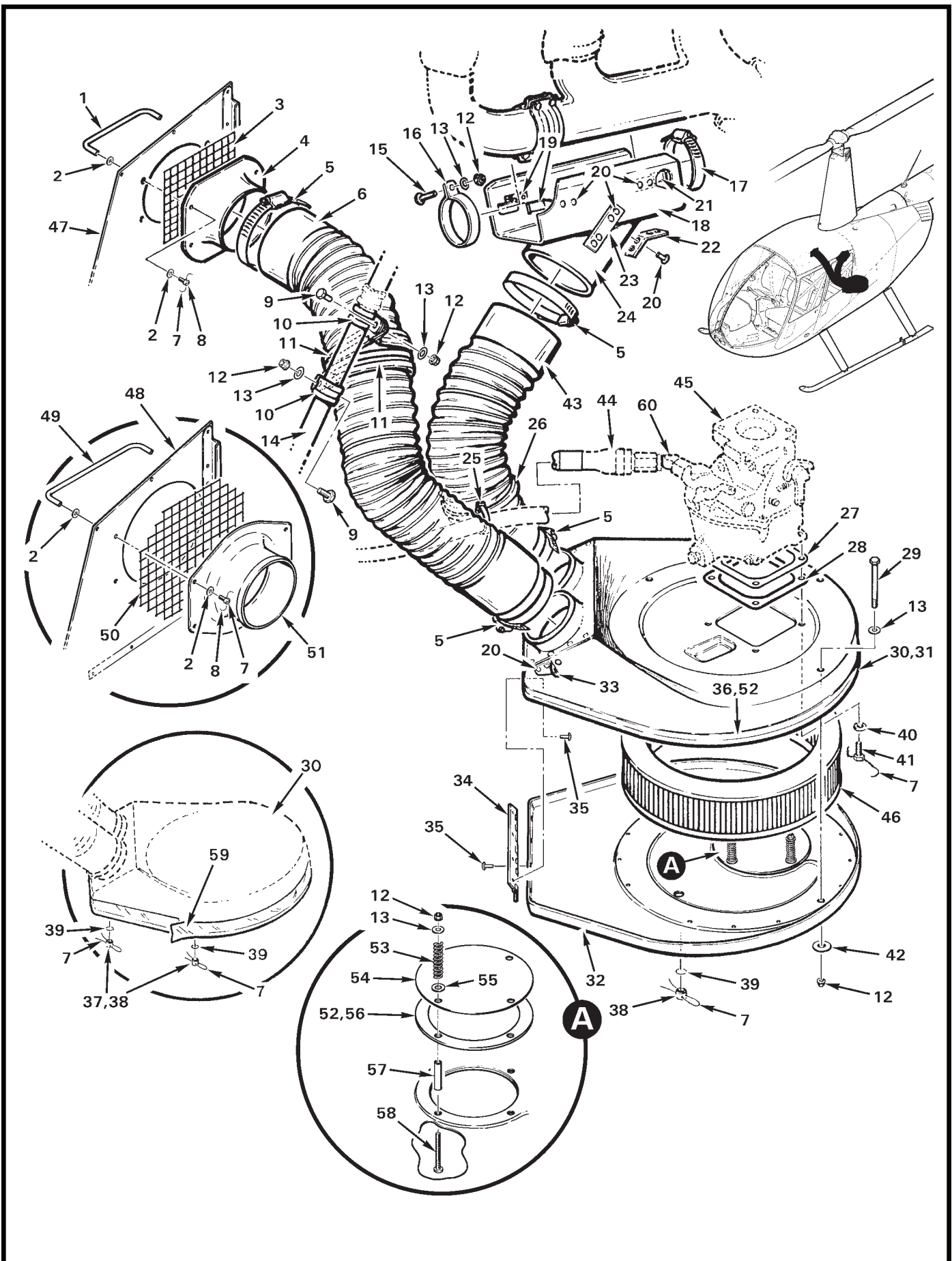

FIGURE AND INDEX NUMBER	PART NUMBER	DESCRIPTION	PARTS AVAIL	QTY PER ASSY
AIR INDUCTION SYSTEM				
71-13-1	A580-2*	Guard	X	2
2	NAS1149FN416P	Washer	X	8
3	A640-2*	Screen	X	1
4	C579-1*	Inlet (small)	X	1
5	B277-56	Clamp	X	4
6	A785-11	Hose	X	1
7	MS20995C32	0.032 in. dia. Safety Wire	X	A/R
8	AN503-8-6	Screw	X	4
9	AN3-4A	Bolt	X	2
10	MS21919WDG14	Clamp	X	2
11	MS21919DG56	Clamp	X	2
12	MS21042L3	Nut	X	11
13	NAS1149F0332P	Washer	X	11
14	C046-2	Frame Tube (Ref)		
15	MS27039C1-09	Screw	X	1
16	A694-1	Clamp	X	1
17	B277-36	Clamp	X	1
18	C568-1	Scoop Assembly (Incl C568-2 scoop and items 19 thru 24) . . .	X	1
	C568-2	Scoop (scoop only)	X	1
19	C568-4	Clip	X	2
20	MS20470AD4	Rivet	X	20
21	C568-5	Clip	X	2
22	C568-7	Clip	X	1
23	C568-6	Clip	X	2
24	C568-3	Tube (tube only)	X	1
25	MS3367-7-9	Ty-Rap (around fuel hose)	X	1
26	MS3367-6-0	Ty-Rap (around air hose)	X	1
27	C615-2	Gasket (aluminum, [2] maximum)	X	A/R
28	C615-1	Gasket (rubber)	X	1
29	AN3-30A	Bolt	X	4
30	C057-5	Air Box Assembly (Incl items 31, 32, 36, and 52)	X	1
31	C957-1	Air Box (Ref, includes items 20 and 33)		
32	C057-8	Bottom Cover Assembly (Incl items 12 [4], 13 [4], 34, 35, 37, and 52 thru 58)	X	1
33	A696-2	Angle (install using item 20)	X	1

NOTES * Ship S/N 0001 thru 1300.

Continues

FIGURE AND INDEX NUMBER	PART NUMBER	DESCRIPTION	PARTS AVAIL	QTY PER ASSY
AIR INDUCTION SYSTEM (Cont'd)				
71-13-34	A516-1	Hinge	X	1
35	MS20470AD3	Rivet	X	4
36	A226-8	Seal (neoprene, 4-ft length; attach using item 52)	X	1
37	A290-1	Drain Valve (Incl items 7, 38, and 39)	X	2
38	A290-2	Body	O	1
39	A290-3	Disc	O	1
40	NAS1149F0463P	Washer	X	4
41	MS20074-04-04	Bolt	X	4
42	AN970-3	Washer	X	4
43	A785-10	Hose	X	1
44	B283-3	Hose Assembly (gascolator-to-carburetor, Ref)		
45	61C22451	Carburetor (Ref, see also Figure 71-5. Lycoming part no.)		
46	B771-2*	Air Filter (supersedes C771-1 air filter).	X	1
47	C378-1	Cowling Assembly – RH (Ref, small hole. Ship S/N 0001 thru 1300. No longer available.)		
48	C378-3**	Cowling Assembly – RH (Ref, large hole. Ship S/N 1301 and higher.)		
49	A580-3**	Guard	X	2
50	A640-4**	Screen	X	1
51	C579-3**	Inlet (large)	X	1
52	B270-18	Adhesive	X	A/R
53	D774-7	Spring	X	4
54	C565-2	Door	X	1
55	NAS1149F0432P	Washer	X	4
56	B425-1	Gasket (attach using item 52)	X	1
57	C130-41	Spacer	X	4
58	MS27039DD1-26	Screw	X	4
59	A701-1	Tape – Aluminum (seal around bottom cover, 180-foot roll)	X	A/R
60	AN823-6D	Elbow (Ref; 45°)		

NOTES * Refer to R44 SB-87. (Revision D and subsequent).
 ** Ship S/N 1301 and higher.

Intentionally Blank

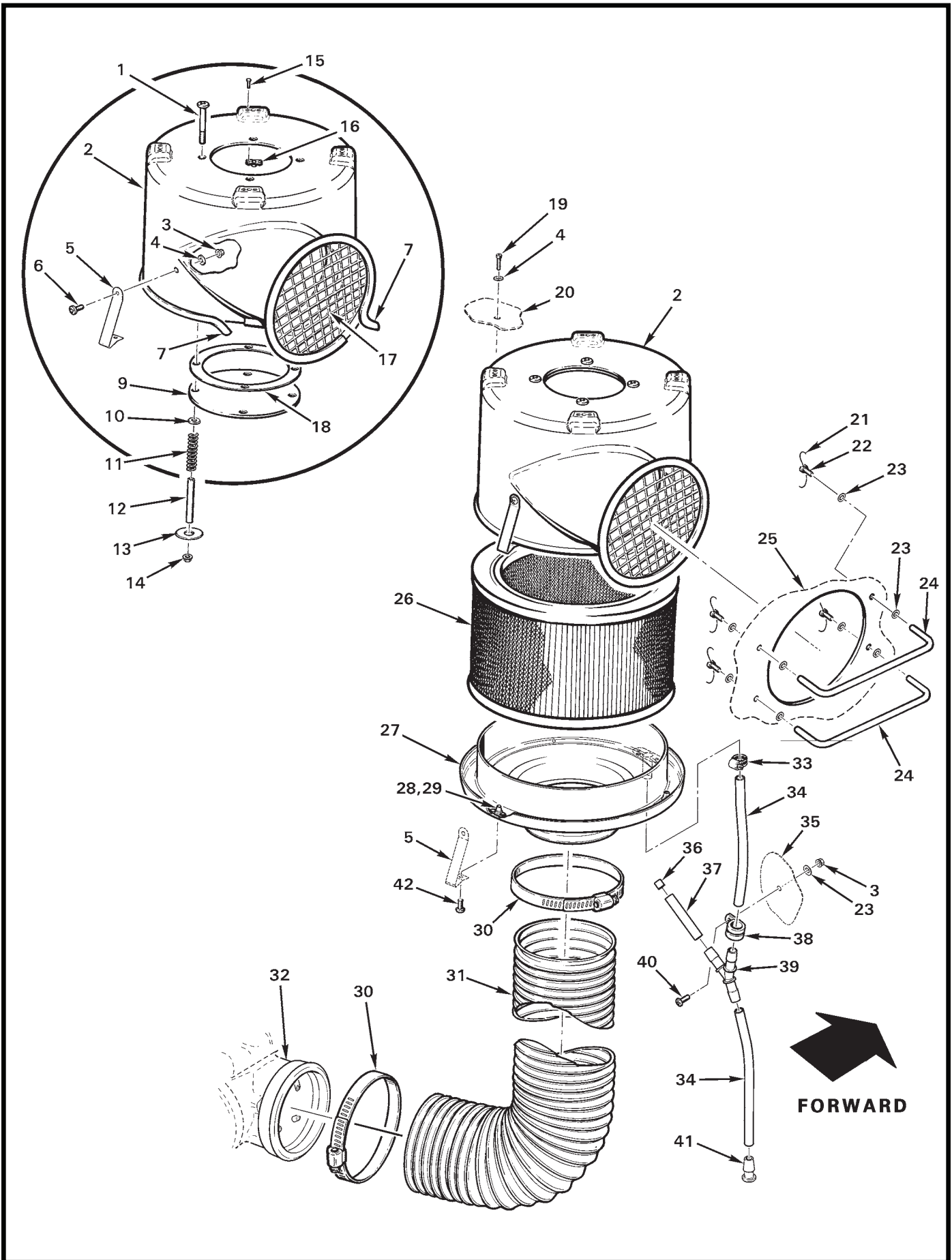

FIGURE AND INDEX NUMBER	PART NUMBER	DESCRIPTION	PARTS AVAIL	QTY PER ASSY
AIR INDUCTION SYSTEM*				
71-17-1	MS27039DD1-26	Screw (or AN3-15A)	X	4
2	D057-2	Airbox Assembly (Incl items 1, and 3 thru 18)	X	1
3	MS21042L08	Nut	X	3
4	NAS1149FN832P	Washer	X	7
5	D738-1	Clip	X	3
6	MS27039C0805	Screw	X	3
7	A226-10	Seal (neoprene; install using item 8)	X	A/R
8	B270-18	Sealant	X	A/R
9	C565-2	Door	X	1
10	NAS1149F0432P	Washer	X	8
11	D774-7	Spring	X	4
12	C130-41	Spacer	X	4
13	C141-18	Washer	X	4
14	MS21042L3	Nut	X	4
15	MS20605R3W4	Rivet	X	8
16	MS21075L08E	Nutplate	X	4
17	A640-3	Screen (install using item 8)	X	1
18	B425-1	Gasket (install using item 8)	X	1
19	NAS1352-08-8P	Screw	X	4
20	C234-1	Firewall - Horizontal (Ref)		
21	MS20995C20	0.020 in. dia. Safety Wire	X	A/R
22	AN503-8-6	Screw	X	4
23	NAS1149FN816P	Washer	X	8
24	A580-3	Guard	X	2
25	C378-3	Cowling Assembly (Ref)		
26	C771-2	Filter - Air	X	1
27	D737-3	Cover Assembly (Incl items 28 and 29)	X	1
28	MS21069L08	Nutplate (install using item 29)	X	3
29	NAS1097AD3	Rivet (not shown)	X	6
30	B277-56	Clamp	X	2
31	A785-31	Hose	X	1

NOTES * Ship S/N 10001 and subsequent.

Continues

FIGURE AND INDEX NUMBER	PART NUMBER	DESCRIPTION	PARTS AVAIL	QTY PER ASSY
AIR INDUCTION SYSTEM* (Cont'd)				
71-17-32	2576630-4**	Control - Fuel (Ref)		
33	B277-4	Clamp	X	1
34	A729-39	Tube	X	2
35	D020	Firewall Assembly - Vertical (Ref)		
36	93657A083	Spacer	X	1
37	A729-40	Tube	X	1
38	MS21919WDG9	Clamp	X	1
39	A457-2	Wye	X	1
40	MS27039C0807	Screw	X	1
41	A457-3	Plug	X	1
42	MS27039C0806	Screw	X	3

NOTES * Ship S/N 10001 and subsequent.
 ** Precision Airmotive part no.

Intentionally Blank

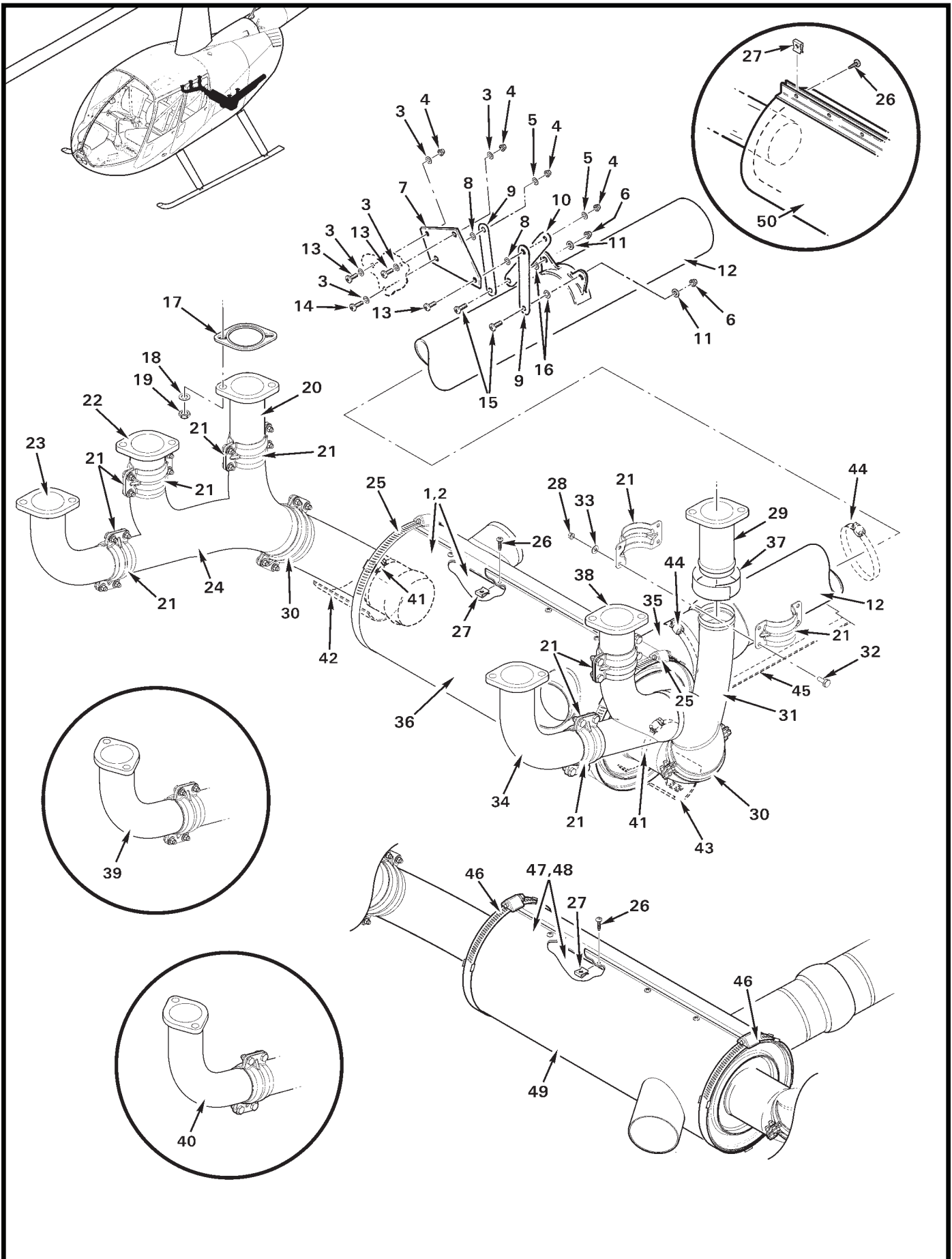

FIGURE AND INDEX NUMBER	PART NUMBER	DESCRIPTION	PARTS AVAIL	QTY PER ASSY
		EXHAUST MUFFLER ASSEMBLY		
71-21-1	C169-37*	Exhaust Muffler Assembly (Includes C169-38 assembly, items 6, 12, 20 thru 25, 29 thru 34, 36, and 38. 7.2-in. dia.)	X	1
	C169-38*	Muffler Assembly (Incl items 32 and 33)	X	1
2	C169-35**	Exhaust Muffler Assembly (Includes C169-36 assembly, items 6, 12, 20 thru 22, 24, 25, 29 thru 33, 36, and 38 thru 40. 7.2-in. dia.)	X	1
	C169-36**	Muffler Assembly (Incl items 32 and 33)	X	1
3	NAS1149FN816P	Washer	X	5
4	MS21042L08	Nut	X	4
5	NAS1149FN832P	Washer	X	2
6	MS21042L3	Nut	X	2
7	C173-1	Bracket	X	1
8	NAS1149FN816P	Washer (as required for proper offset, 1 min, 4 max)	X	A/R
9	C173-2	Strap	X	2
10	C173-3	Strap	X	1
11	NAS1149F0363P	Washer	X	2
12	C169-18	Tail Pipe (Ref)		
13	MS27039C0806	Screw	X	3
14	MS27039C0807	Screw	X	1
15	MS27039C1-06	Screw (or MS27039C1-07)	X	2
16	NAS1149F0332P	Washer (as required for proper offset, 1 min, 3 max)	X	A/R
17	77611	Gasket	X	6
18	NAS1149F0532P	Washer	X	12
19	21FKF-518	Nut	X	12
20	C169-8	Riser (cylinder #2)	X	1
21	A169-14	Bead Clamp	X	12
22	C169-10	Riser (cylinder #4)	X	1
23	C169-30*	Riser (cylinder #6)	X	1
24	C169-6	Collector (RH)	X	1
25	C169-44	Clamp	X	2
26	MS51861-35	Screw	X	9
27	A6052-8Z-1	Nut (or A6052-8Z-1)	X	4
28	MS21043-3	Nut (or MS21042L3)	X	32
29	C169-7	Riser (cylinder #1)	X	1
30	C169-25	Bead Clamp	X	4
31	C169-5	Collector (LH)	X	1

NOTES * IO-540 Engine.
 ** O-540 Engine.

Continues

FIGURE AND INDEX NUMBER	PART NUMBER	DESCRIPTION	PARTS AVAIL	QTY PER ASSY
EXHAUST MUFFLER ASSEMBLY (Cont'd)				
71-21-31	C169-5	Collector (LH)	X	1
32	AN3-4A	Bolt (or AN3C4A)	X	32
33	NAS1149F0332P	Washer	X	32
34	C169-29*	Riser (cylinder #5)	X	1
35	C169-17	Exhaust Pipe (Ref)		
36	C169-39	Shroud Assembly (Revision T and higher. Includes items 30, 31, and 39.)	X	1
37	A701-10	Tape (1" stainless steel; under each bead clamp)	X	A/R
38	C169-9	Riser (cylinder #3)	X	1
39	C169-12**	Riser (cylinder #6)	X	1
40	C169-11**	Riser (cylinder #5)	X	1
41	B277-036	Clamp (Ref, see Figure 71-25)		
42	D314-2	Shield Assembly (Ref, see Figure 71-25)		
43	D314-1	Shield Assembly (Ref, see Figure 71-25)		
44	B277-48	Clamp (Ref, see Figure 71-25)		
45	D317-1	Shield Assembly (Ref, see Figure 71-25)		
46	C169-34	Clamp	X	2
47	C169-1**	Exhaust Muffler Assembly (Includes C169-3 assembly, items 6 thru 10, and 21 thru 29. 6.0-in. dia.)	X	1
	C169-3**	Muffler Assembly (Incl items 12 and 35)	O	1
48	C169-31*	Exhaust Muffler Assembly (Includes C169-32 assembly, items 6, 7, 9, 10, 21 thru 26, 28, 29, 37, and 38. 6.0-in. dia.)	X	1
	C169-32*	Muffler Assembly (Incl items 12 and 35)	O	1
49	C169-2	Shroud Assembly (revision K thru S; 6.0-in. dia.)	X	1
50	C169-2	Shroud Assembly (revision J and prior; 6.0-in. dia.)	O	1

NOTES * IO-540 Engine.
 ** O-540 Engine.

Intentionally Blank

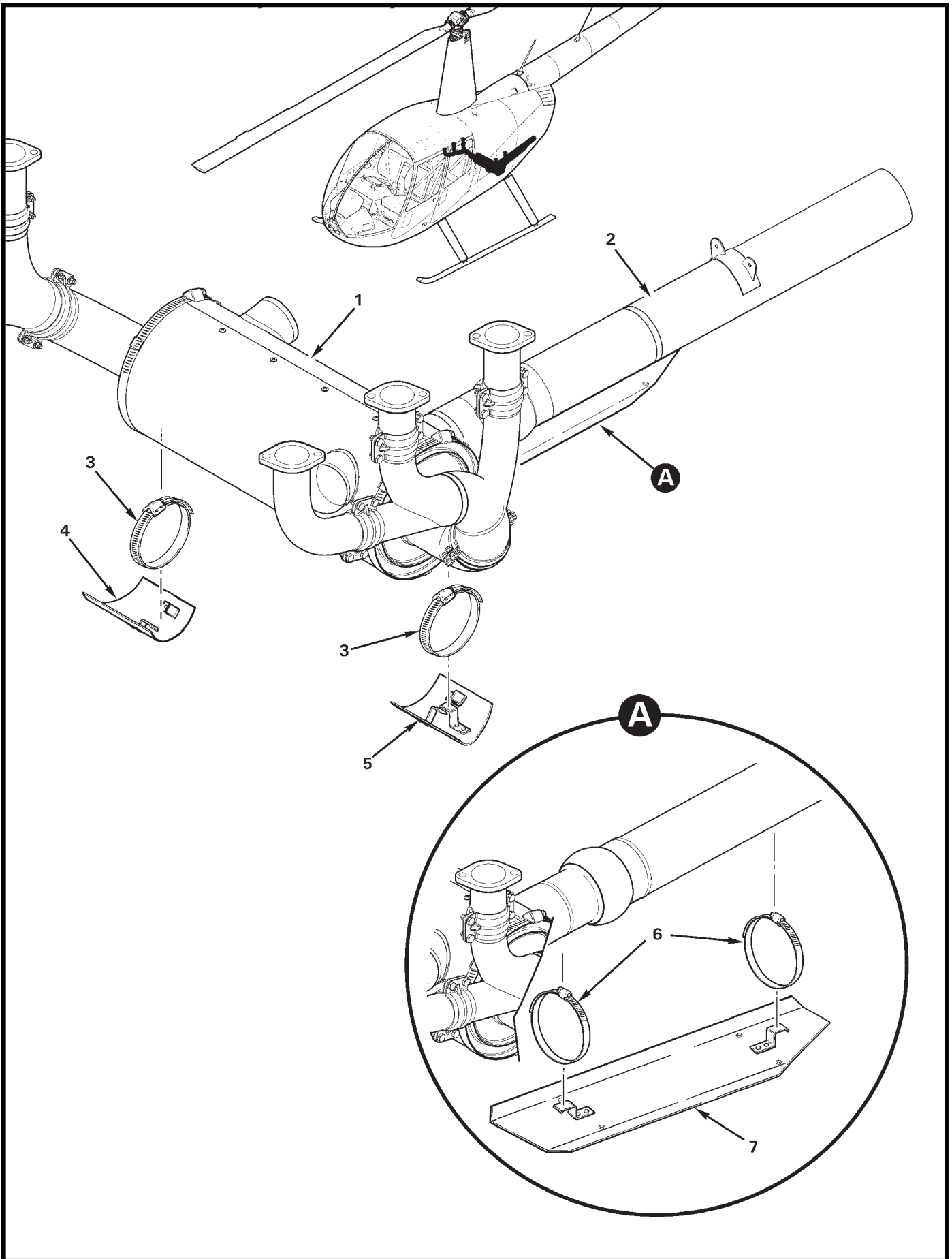

FIGURE AND INDEX NUMBER	PART NUMBER	DESCRIPTION	PARTS AVAIL	QTY PER ASSY
EXHAUST MUFFLER SHIELD ASSEMBLY				
71-25-1	C169-35	Exhaust Muffler Assembly (Ref)		
	C169-37	Exhaust Muffler Assembly (Ref, not shown)		
	C169-1 *	Exhaust Muffler Assembly (Ref, not shown)		
	C169-31 *	Exhaust Muffler Assembly (Ref, not shown)		
	2 C169-18	Tail Pipe (Ref)		
	3 B277-036	Clamp	X	2
	4 D314-2	Shield Assembly (RH)	X	1
5 D314-1	Shield Assembly (LH)	X	1	
6 B277-48	Clamp	X	2	
7 D317-1	Shield Assembly	X	1	

NOTES * Earlier R44s.

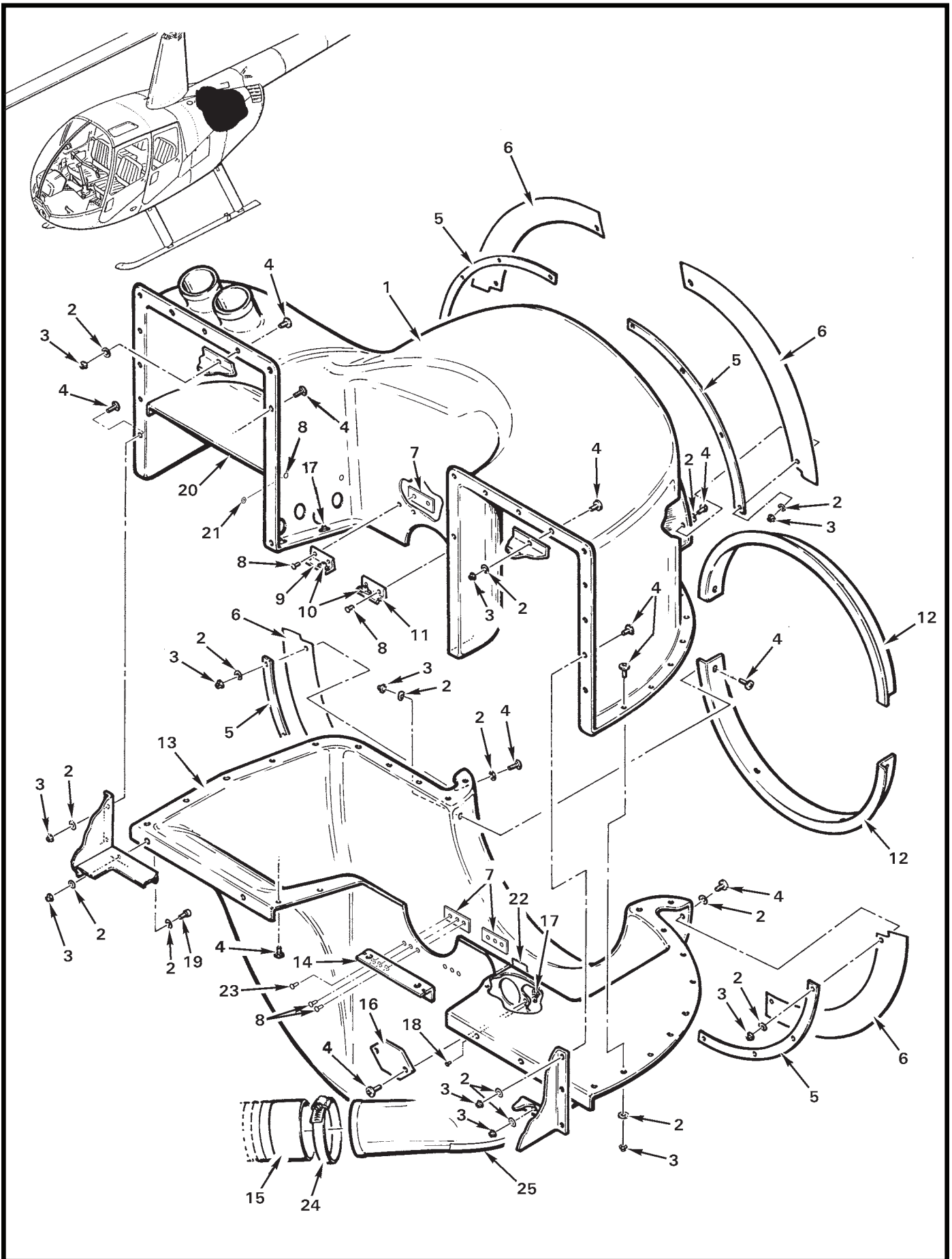

FIGURE AND INDEX NUMBER	PART NUMBER	DESCRIPTION	PARTS AVAIL	QTY PER ASSY
SCROLL ASSEMBLY*				
71-27-1	C236-1	Scroll Assembly - Upper (Includes items 7 thru 11, 17, 20, 21 and 23. Not available; to replace order item 26.)	X	1
2	NAS1149FN816P	Washer	X	66
3	MS21042L08	Nut	X	66
4	MS27039C0806	Screw	X	63
5	D229-2	Retainer	X	4
6	D229-3	Seal	X	4
7	A185-3	Plate	X	4
8	MS20470AD4	Rivet	X	8
9	A185-2	Bracket	X	1
10	MS21075L3E	Nutplate (install using item 18)	X	2
11	A185-5	Bracket	X	1
12	D229-1	Lip	X	2
13	C236-2	Scroll Assembly - Lower (Incl items 7, 8, 14, 17, 18, 22, 23, and 25)	X	1
14	A185-1	Bracket	X	1
15	A785-12	Hose (scroll-to-muffler shroud, Ref; see Figure 21-37)		
16	D229-4	Cover	X	1
17	MS21069L08	Nutplate	X	4
18	MS20426AD3	Rivet	X	16
19	NAS1352-08-8P	Screw	X	5
20	D168-1	Vane Assembly (install using item 8)	X	1
21	NAS620-5	Washer (for shimming between items 1 and 20, [2] places inboard)	X	A/R
22	A701-1	Tape - Aluminum (1 in. width)	X	A/R
23	MS20426AD4	Rivet (at outboard positions)	X	2
24	B277-36	Clamp (Ref, see Figure 21-37)		
25	A701-2	Tape-Aluminum (6 in. width)	X	A/R
26	C027-2A	Scroll Set (Incl items 1, 4, 13, and 16)	X	1

NOTES * Ship S/N 0001 thru 9999.

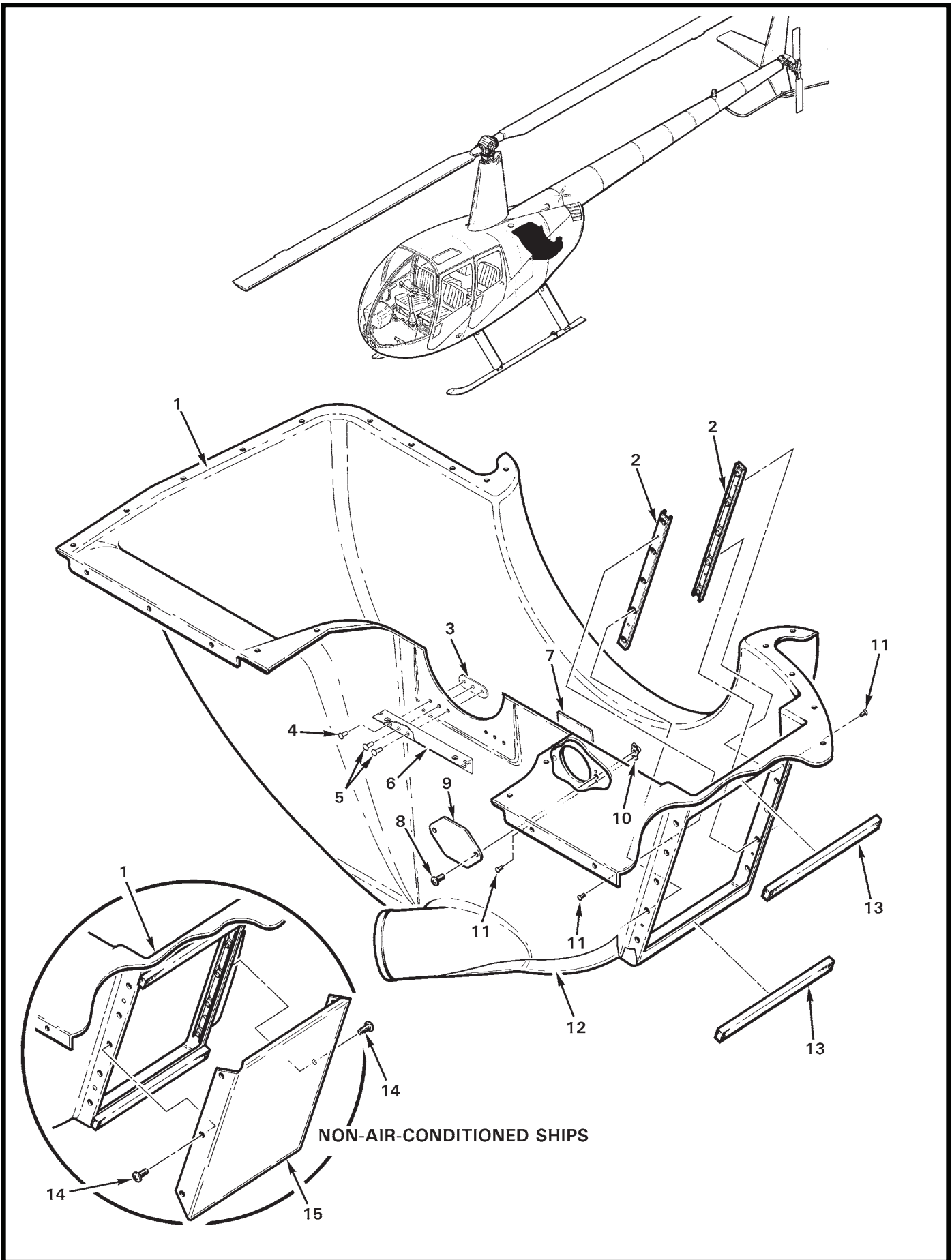

FIGURE AND INDEX NUMBER	PART NUMBER	DESCRIPTION	PARTS AVAIL	QTY PER ASSY
SCROLL ASSEMBLY*				
71-29-1	C236-5	Scroll Assembly - Lower (Incl items 2 thru 7, and 10 thru 13) . .	X	1
2	A738-35	Gang Channel	X	2
3	A185-3	Plate	X	2
4	MS20426AD4	Rivet (at outboard locations)	X	2
5	MS20470AD4	Rivet	X	4
6	A185-1	Bracket	X	1
7	A701-1	Tape	X	A/R
8	MS27039C0806	Screw	X	2
9	D229-4	Cover	X	1
10	MS21069L08	Nutplate	X	2
11	MS20426AD3	Rivet	X	8
12	A701-2	Tape - Aluminum (6 in. width)	X	A/R
13	A260-11	Tape	X	2
14	MS27039C1-07	Screw	X	6
15	D854-1	Cover (non-air-conditioned ships only)	X	1
16	C027-3A/C	Scroll Set (Includes items 1, 8, 9, and item 1 from Figure 71-29.) .	X	1

NOTES * Ship S/N 10001 and subsequent.

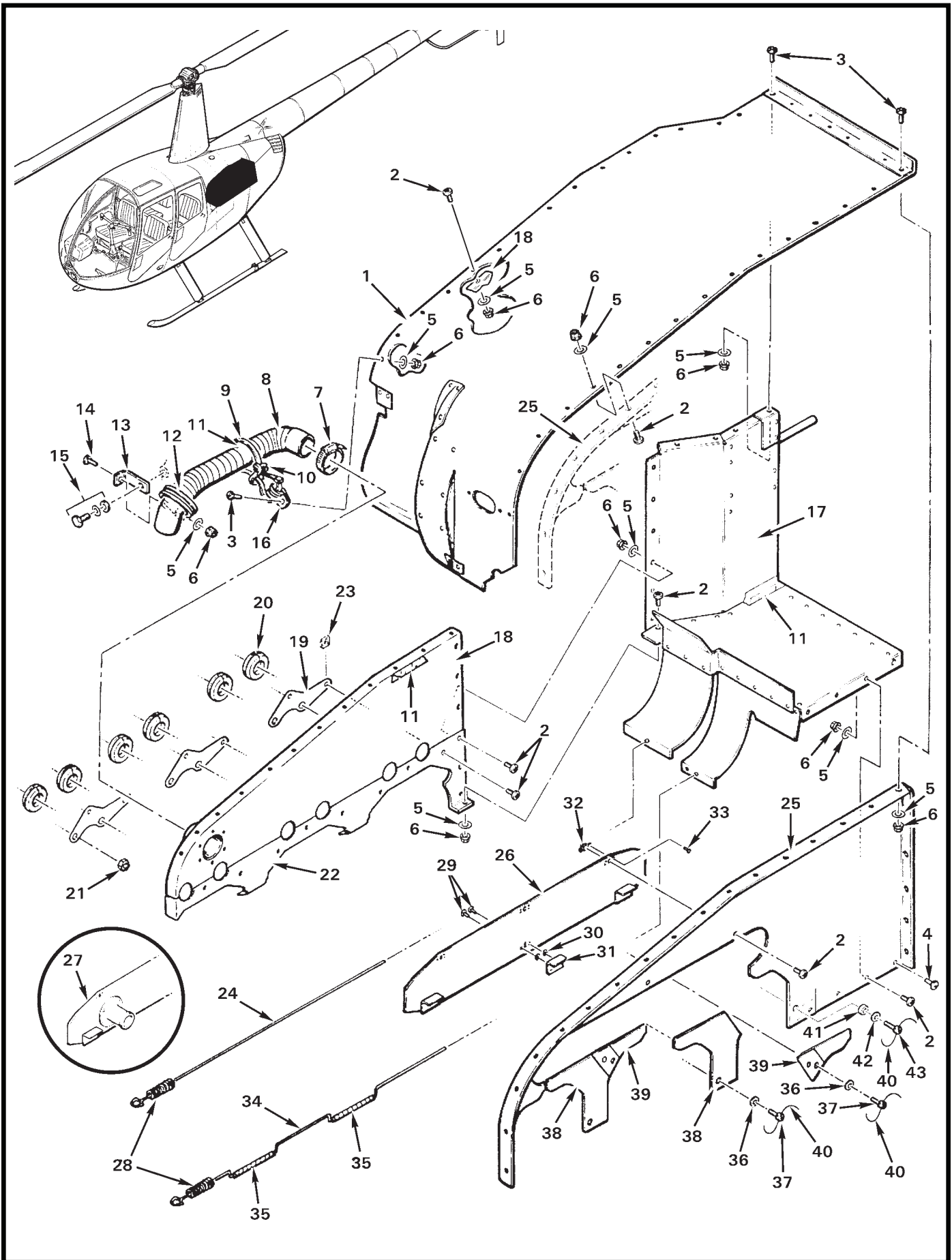

FIGURE AND INDEX NUMBER	PART NUMBER	DESCRIPTION	PARTS AVAIL	QTY PER ASSY
		LEFT SIDE COOLING PANELS*		
71-31-1	C312-1	Cover Assembly	X	1
2	MS27039C0806	Screw	X	3
3	MS27039C0805	Screw	X	50
4	MS27039C0806	Screw (aft location as shown)	X	1
5	NAS1149FN816P	Washer	X	51
6	MS21042L08	Nut	X	51
7	B277-16	Clamp	X	4
8	A785-19	Hose	X	1
9	MS3367-7-9	Ty-Rap	X	1
10	MS3367-5-9	Ty-Rap	X	1
11	A701-1	Tape - Aluminum	X	A/R
12	MS21919WDG20	Clamp	X	1
13	C357-1	Clip	X	1
14	MS27039C0807	Screw	X	1
15	—	Existing Engine Hardware (Ref)		
16	MS21919WDG2	Clamp	X	1
17	C313-7	Panel Assembly	X	1
18	C310-1	Panel	X	1
19	A484-3	Attach Plate	X	3
20	B401-1	Grommet	X	6
21	—	Nut (Ref, existing)		
22	C310-2	Panel	X	1
23	B162-2	Clipnut	X	6
24	C487-1	Retainer (straight)	X	1
25	C305-11	Panel	X	1
26	C449-1	Cover Assembly (Incl items 29 thru 33)	X	1
27	C449-3	Cover Assembly (For ships with frame-mounted battery. Includes items 29 thru 33.)	X	1
28	D774-13	Spring (alternate part no. C0420-042-1250S)	X	2
29	MS20470AD4	Rivet	X	6
30	NAS620-5	Washer	X	6
31	A449-4	Clip	X	3

NOTES * Ship S/N 0001 thru 9999.

Continues

FIGURE AND INDEX NUMBER	PART NUMBER	DESCRIPTION	PARTS AVAIL	QTY PER ASSY
LEFT SIDE COOLING PANELS* (Cont'd)				
71-31-32	MS21069L08	Nutplate	X	3
33	NAS1097AD3	Rivet	X	6
34	C487-2	Retainer (bent)	X	1
35	B161-102	Spirap	X	A/R
36	NAS1149F0432P	Washer	X	11
37	NAS1352-4H10P	Screw	X	11
38	A305-8	Panel	X	2
39	A305-7	Cover	X	2
40	MS20995C32	0.032 in. dia. Safety Wire	X	A/R
41	C130-9	Spacer	X	1
42	A141-11	Washer	X	1
43	NAS1352-4H14P	Screw	X	1

NOTES * Ship S/N 0001 thru 9999.

Intentionally Blank

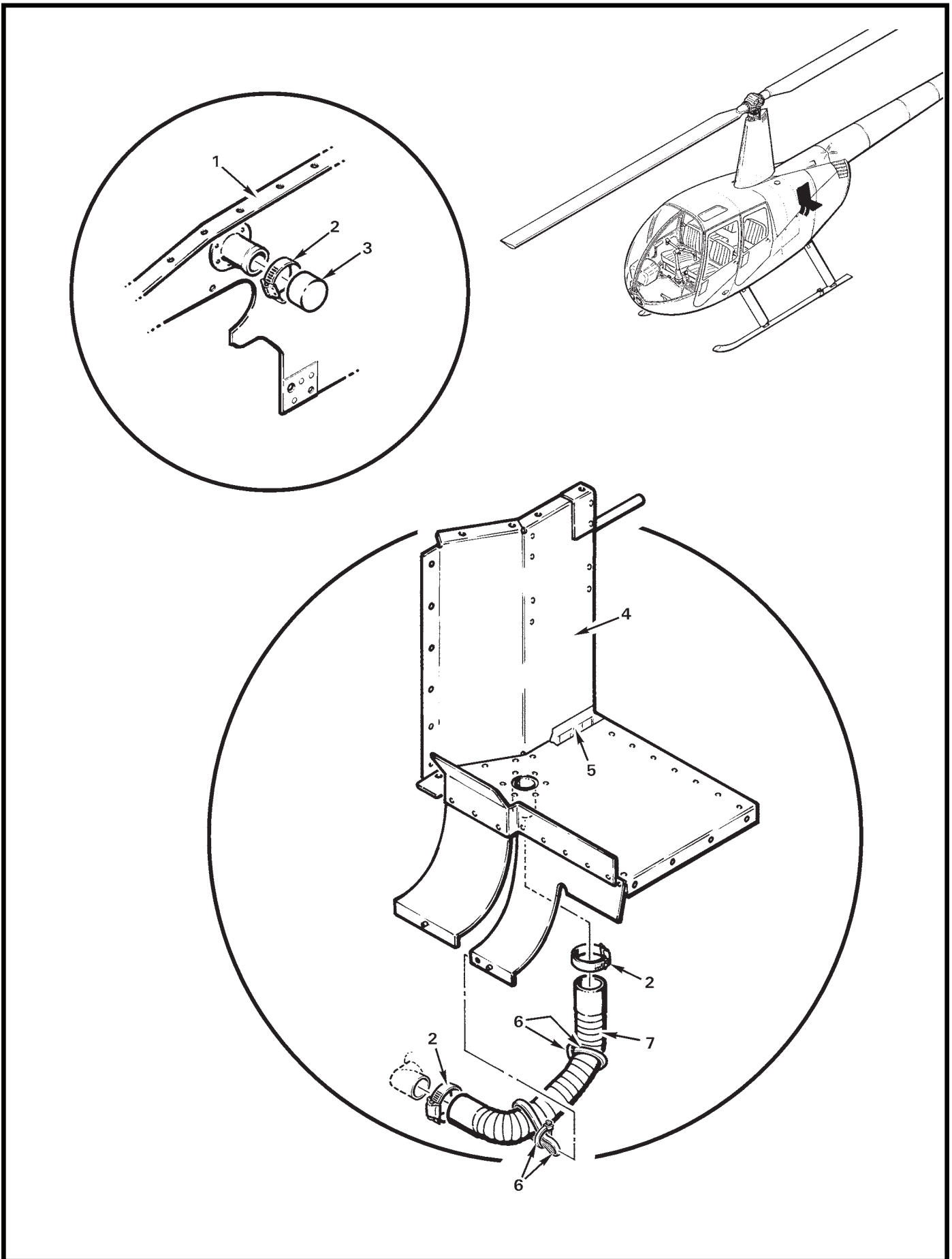

FIGURE AND INDEX NUMBER	PART NUMBER	DESCRIPTION	PARTS AVAIL	QTY PER ASSY
		LEFT SIDE COOLING PANELS*		
71-35-1	C305-7	Panel Assembly (Ref, no longer available. Superseded by C305-11 panel assembly; see Figure 71-31.)		
2	B277-16	Clamp	X	2
3	A959-5	Cap (for R44s with forward or tailcone battery)	X	1
4	C313-1	Panel Assembly (for earlier R44s)	X	1
5	A701-1	Tape - Aluminum	X	A/R
6	MS3367-4-9	Ty-Rap	X	4
7	A785-7	Hose (alternator cooling; 1.00 inch dia., 15.00 inch length) . . .	X	1

NOTES * Ship S/N 0001 thru 9999.

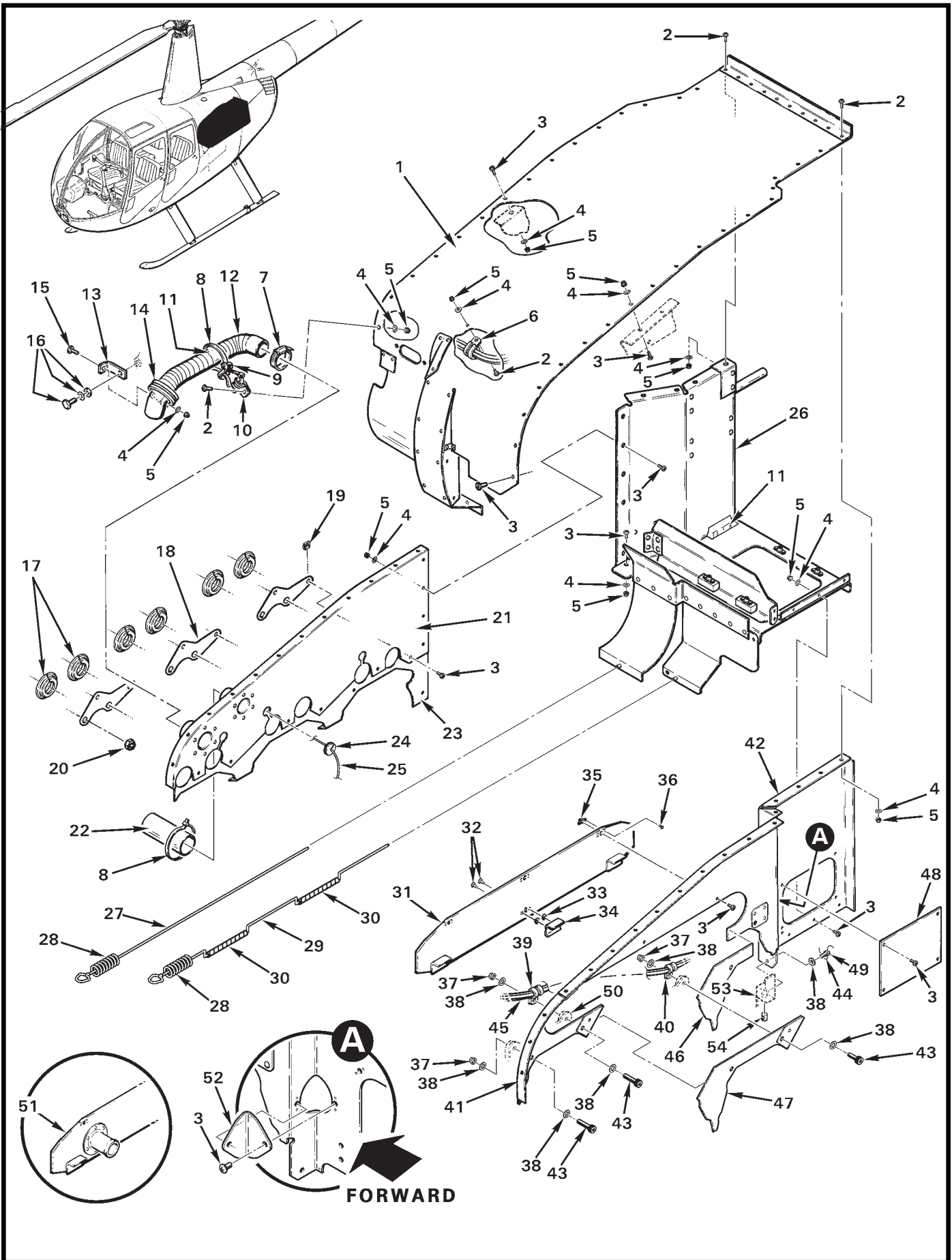

FIGURE AND INDEX NUMBER	PART NUMBER	DESCRIPTION	PARTS AVAIL	QTY PER ASSY
		LEFT SIDE COOLING PANELS*		
71-37-1	D381-1	Cover	X	1
2	MS27039C0806	Screw	X	5
3	MS27039C0805	Screw	X	58
4	NAS1149FN816P	Washer	X	48
5	MS21042L08	Nut	X	48
6	MS21919WDG7	Clamp	X	1
7	B277-16	Clamp	X	1
8	MS3367-7-9	Ty-Rap (large)	X	2
9	MS3367-5-9	Ty-Rap (small)	X	1
10	MS21919WDG2	Clamp	X	1
11	A701-1	Tape - Aluminum	X	A/R
12	A785-19	Hose	X	1
13	C357-1	Clip	X	1
14	MS21919WDG20	Clamp	X	1
15	MS27039C0807	Screw	X	1
16	—	Existing Engine Hardware (Ref)		
17	B401-2	Grommet	X	6
18	A484-3	Plate	X	3
19	B162-2	Clipnut	X	6
20	383-B	Nut (Ref, supplied with engine)	X	6
21	C310-4	Panel (upper)	X	1
22	A729-10	Tube	X	1
23	C310-5	Panel (lower)	X	1
24	MS35489-2	Grommet	X	3
25	—	Injector Line (Ref)		
26	D751-1	Panel Assembly	X	1
27	C487-1	Retainer (straight)	X	1
28	D774-13	Spring (alternate part no. C0420-042-1250S)	X	2
29	C487-2	Retainer (bent)	X	1
30	B161-102	Spirap	X	A/R
31	C449-1	Cover Assembly (Incl items 32 thru 36)	X	1

NOTES * Ship S/N 10001 and subsequent.

Continues

FIGURE AND INDEX NUMBER	PART NUMBER	DESCRIPTION	PARTS AVAIL	QTY PER ASSY
LEFT SIDE COOLING PANELS* (Cont'd)				
71-37-32	MS20470AD4	Rivet	X	6
33	NAS620-5	Washer	X	6
34	A449-4	Clip	X	3
35	MS21069L08K	Nutplate	X	6
36	NAS1097AD3	Rivet	X	6
37	MS21042L3	Nut	X	6
38	NAS1149F0332P	Washer	X	12
39	MS21919WDG6	Clamp	X	1
40	MS21919WDG4	Clamp	X	1
41	D380-7	Panel (forward, small)	X	1
42	D380-1	Panel (aft, large)	X	1
43	NAS1351-3-16P	Screw	X	6
44	MS20995C32	0.032 in. dia. Safety Wire	X	A/R
45	—	Ignition Harness (Ref)		
46	D380-9	Panel Assembly	X	1
47	D380-3	Panel	X	1
48	A412-1	Cover	X	1
49	NAS1351-3-6P	Screw	X	1
50	—	Engine Cylinder (Ref)		
51	C449-3	Cover Assembly (For ships with engine-compartment battery. Includes items 32 thru 36.)	X	1
52	D695-6	Cover	X	1
53	C145	Engine Assembly (Ref; IO-540-AE1A5)		
54	D143-1	Nut Assembly (cylinder head)	X	1

NOTES * Ship S/N 10001 and subsequent.

Intentionally Blank

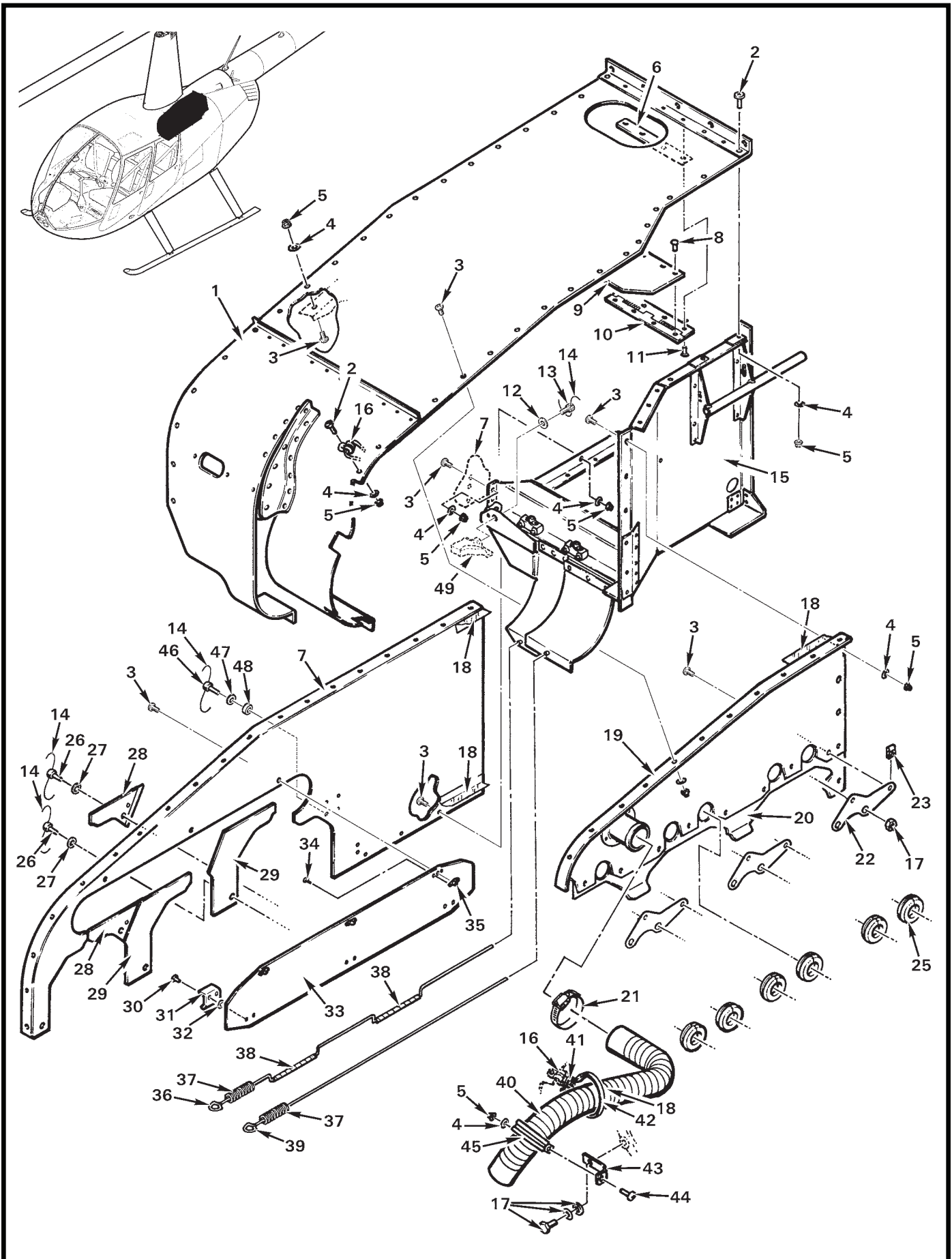

FIGURE AND INDEX NUMBER	PART NUMBER	DESCRIPTION	PARTS AVAIL	QTY PER ASSY
RIGHT SIDE COOLING PANELS*				
71-41-1	C308-1	Cover Assembly	X	1
2	MS27039C0806	Screw	X	3
3	MS27039C0805	Screw	X	52
4	NAS1149FN816P	Washer	X	51
5	MS21042L08	Nut	X	51
6	A775-3	Spacer	X	1
7	C305-8	Panel Assembly (use with C649-2 large oil cooler only)	X	1
	C305-2	Panel Assembly (use with C649-1 small oil cooler, not shown)	X	1
8	MS20426AD3	Rivet	X	4
9	A775-1	Cover Assembly (Incl items 8 and 10)	X	1
10	A775-2	Hinge	X	1
11	MS20470AD3	Rivet	X	4
12	NAS1149F0332P	Washer	X	1
13	NAS1352-3H6P	Screw (secures item 15 to cylinder head)	X	1
14	MS20995C32	0.032 in. dia. Safety Wire	X	A/R
15	C309-5	Panel Assembly (use with C649-2 large oil cooler only)	X	1
	C309-1	Panel Assembly (use with C649-1 small oil cooler, not shown)	X	1
16	MS21919WDG2	Clamp	X	1
17	—	Existing Engine Hardware (Ref)		
18	A701-1	Tape - Aluminum	X	A/R
19	C306-1	Panel Assembly (upper; includes tube)	X	2
20	C306-2	Panel Assembly (lower)	X	2
21	B277-16	Clamp	X	1
22	A484-3	Attach Plate	X	3
23	B162-2	Clipnut	X	6
24	—	Existing Engine Nut (Ref)		
25	B401-1	Grommet	X	6
26	NAS1352-4H10P	Screw	X	11
27	NAS1149F0432P	Washer	X	11
28	A305-7	Panel Assembly	X	2
29	A305-8	Panel	X	2

NOTES * Ship S/N 0001 thru 9999.

Continues

FIGURE AND INDEX NUMBER	PART NUMBER	DESCRIPTION	PARTS AVAIL	QTY PER ASSY
RIGHT SIDE COOLING PANELS* (Cont'd)				
71-41-30	MS20470AD4	Rivet	X	6
31	A449-4	Clip	X	3
32	NAS620-5	Washer	X	6
33	C449-1	Cover Assembly (Includes items 30 thru 32, and 34)	X	1
34	NAS1097AD3	Rivet (flush head)	X	6
35	MS21069L08	Nutplate	X	3
36	C487-2	Retainer (bent)	X	1
37	D774-13	Spring (alternate part no. C0420-042-1250S)	X	2
38	B161-102	Spirap	X	A/R
39	C487-1	Retainer (straight)	X	1
40	A785-19	Hose (magneto cooling)	X	1
41	MS3367-5-9	Ty-Rap (around item 42)	X	1
42	MS3367-7-9	Ty-Rap	X	1
43	C357-1	Clip	X	1
44	MS27039C0807	Screw	X	1
45	MS21919WDG20	Clamp	X	1
46	NAS1352-4H14P	Screw	X	1
47	A141-11	Washer	X	1
48	C130-9	Spacer	X	1
49	C145	Engine Assembly (Ref; O-540-F1B5)		

NOTES * Ship S/N 0001 thru 9999.

Intentionally Blank

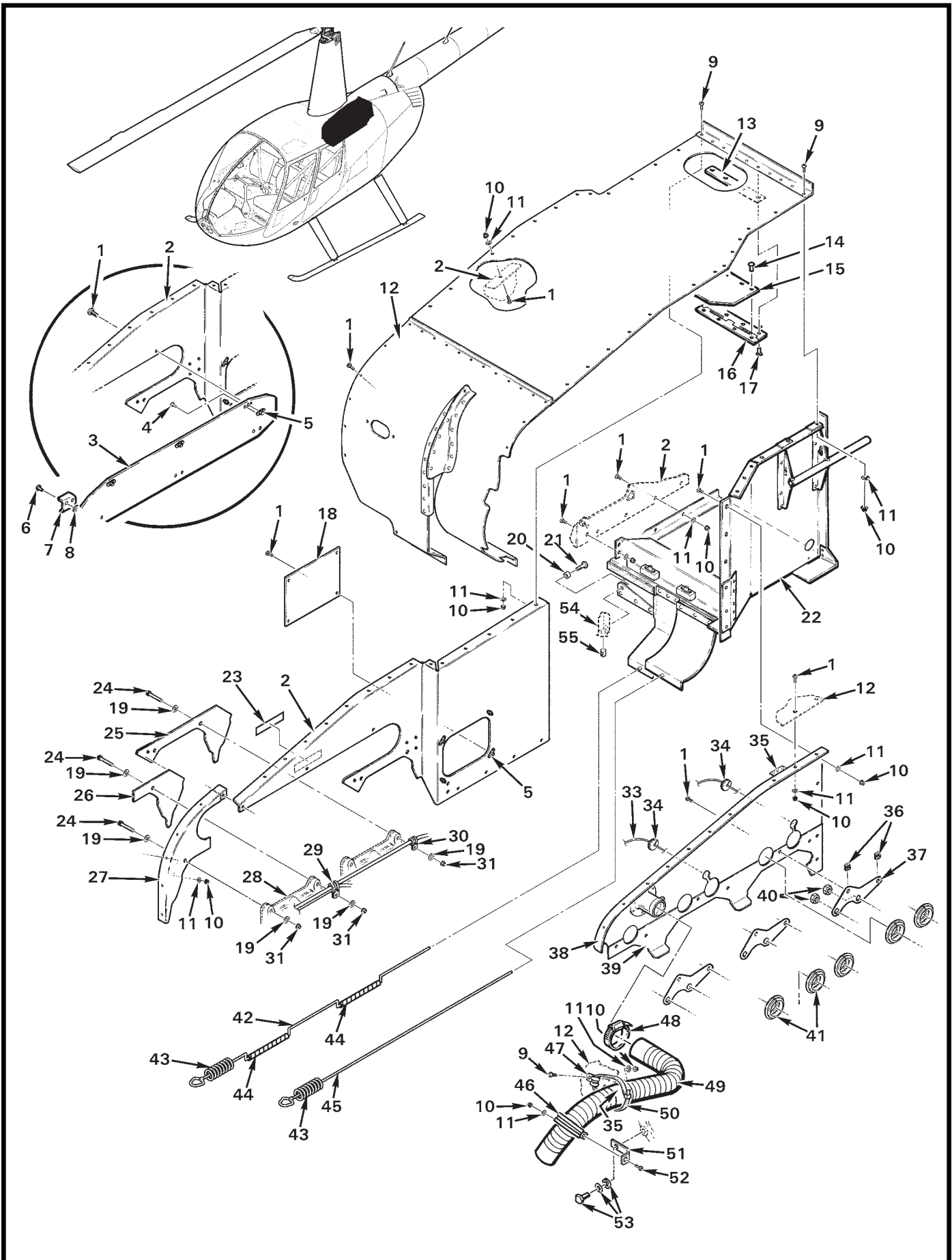

FIGURE AND INDEX NUMBER	PART NUMBER	DESCRIPTION	PARTS AVAIL	QTY PER ASSY
RIGHT SIDE COOLING PANELS*				
71-45-1	MS27039C0805	Screw	X	56
2	D380-10	Panel Assembly (Incl items 5 and 23)	X	1
3	C449-1	Cover Assembly (Incl items 4 thru 8)	X	1
4	NAS1097AD3	Rivet (flush head)	X	6
5	MS21069L08	Nutplate	X	3
6	MS20470AD4	Rivet	X	6
7	A449-4	Clip	X	3
8	NAS620-5	Washer	X	6
9	MS27039C0806	Screw	X	3
10	MS21042L08	Nut	X	52
11	NAS1149FN816P	Washer	X	52
12	D382-1	Cover Assembly (Incl items 13 and 15)	X	1
13	A775-3	Spacer	O	1
14	MS20426AD3	Rivet	X	4
15	A775-1	Cover Assembly (Incl items 14 and 16)	X	1
16	A775-2	Hinge	X	1
17	MS20470AD3	Rivet	X	4
18	A412-1	Cover	X	1
19	NAS1149F0332P	Washer	X	13
20	A130-51	Spacer	X	1
21	NAS6603-5	Bolt	X	1
22	C309-6	Panel Assembly	X	1
23	D682-18	Decal (spark plug requirements)	X	1
24	NAS1351-3-16P	Screw	X	6
25	D380-3	Panel Assembly	X	1
26	D380-9	Panel	X	1
27	D380-12	Panel	X	1
28	—	Engine Cylinder (Ref)		
29	MS21919WDG6	Clamp	X	1
30	MS21919WDG4	Clamp	X	1
31	MS21042L3	Nut	X	6

NOTES * Ship S/N 10001 and subsequent.

Continues

FIGURE AND INDEX NUMBER	PART NUMBER	DESCRIPTION	PARTS AVAIL	QTY PER ASSY
RIGHT SIDE COOLING PANELS* (Cont'd)				
71-45-32	—	Ignition Harness (Ref)		
33	—	Injector Line (Ref)		
34	MS35489-2	Grommet	X	3
35	A701-1	Tape - Aluminum	X	A/R
36	B162-2	Clipnut	X	6
37	A484-3	Plate	X	3
38	C306-4	Panel	X	1
39	C306-5	Panel	X	1
40	383-B**	Nut (supplied with engine)	X	6
41	B401-2	Grommet	X	5
42	C487-2	Retainer (bent)	X	1
43	D774-13	Spring (alternate part no. C0420-042-1250S)	X	2
44	B161-102	Spirap	X	A/R
45	C487-1	Retainer (straight)	X	1
46	MS21919WDG20	Clamp	X	1
47	MS21919WDG2	Clamp	X	1
48	B277-16	Clamp	X	1
49	A785-19	Hose	X	1
50	MS3367-7-9	Ty-Rap	X	1
51	C357-1	Clip	X	1
52	MS27039C0807	Screw	X	1
53	—	Existing Engine Hardware (Ref)		
54	C145	Engine Assembly (Ref; IO-540-AE1A5)		
55	D143-1	Nut Assembly (cylinder head)	X	1

NOTES * Ship S/N 10001 and subsequent.
 ** Lycoming part no.

Intentionally Blank

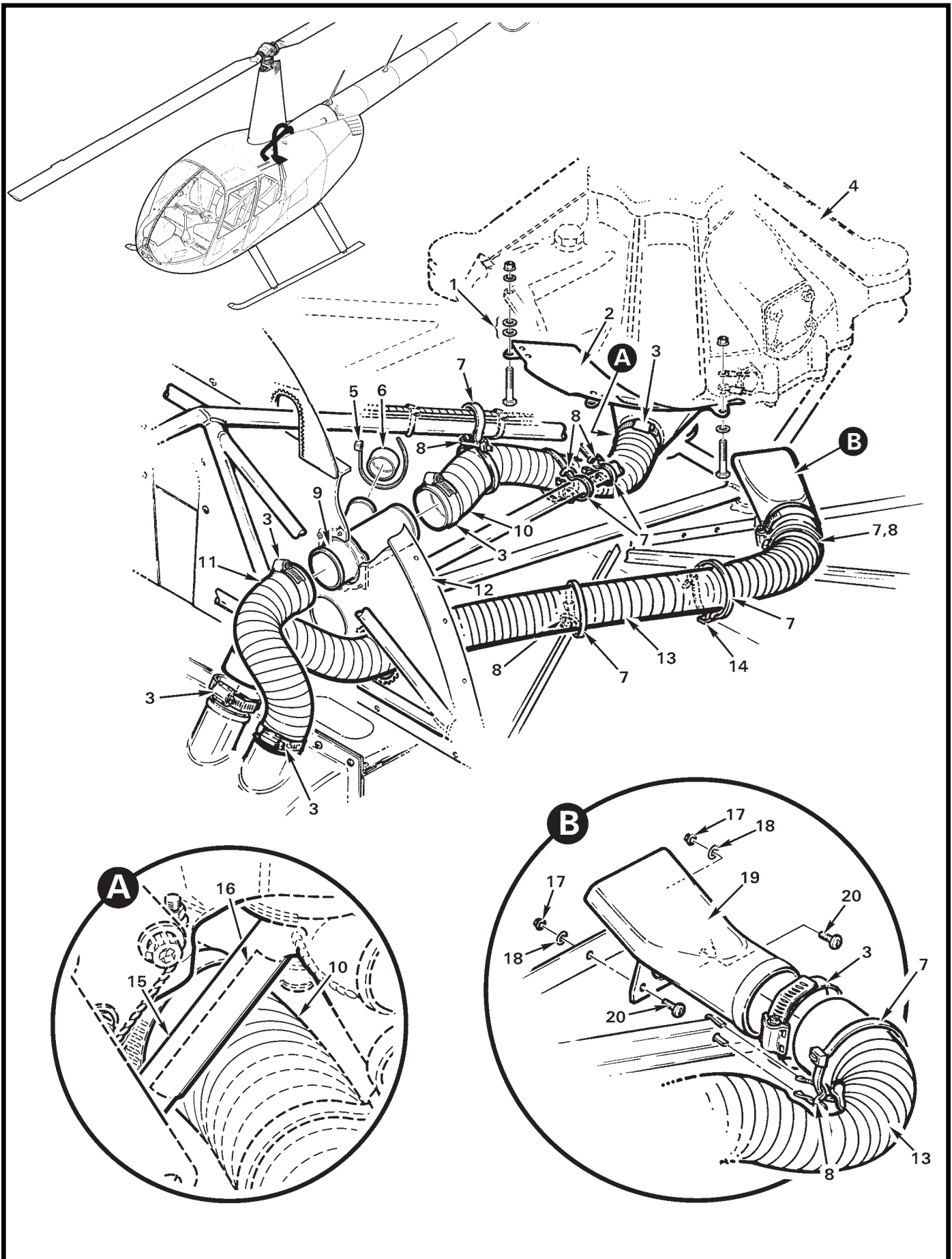

FIGURE AND INDEX NUMBER	PART NUMBER	DESCRIPTION	PARTS AVAIL	QTY PER ASSY
MAIN ROTOR GEARBOX COOLING HOSES				
71-49-1	NAS1149F0432P	Washer (or NAS1149F0463P as required to fill gap between item 2 and sump; [2] NAS1149F0463P washers maximum)	X	A/R
2	C747-1	Baffle Assembly	X	1
3	B277-28	Clamp	X	6
4	C006	Main Rotor Gearbox (Ref, see Figure 63-1)		
5	MS3367-7-9	Ty-Rap	X	A/R
6	A959-4	Cap (manual controls only)	X	1
7	MS3367-3-9	Ty-Rap	X	A/R
8	MS3367-5-9	Ty-Rap	X	A/R
9	C371-1	Tube Assembly	X	1
10	A785-6	Hose (to main rotor gearbox)	X	1
11	A785-17	Hose (to scroll)	X	1
12	C723-1	Bulkhead (Ref, see Figure 53-15)		
13	A785-16	Hose (air supply)	X	1
14	MS21919WDG4	Clamp	X	1
15	C020-1	Upper Frame Assembly (Ref, see Figure 52-19)		
16	A701-3	Tape (0.5 in. wide polyethylene)	X	A/R
17	MS21042L08	Nut	X	1
18	NAS1149FN816P	Washer	X	2
19	C749-1	Nozzle Assembly	X	1
20	MS27039C0806	Screw	X	2

NOTES

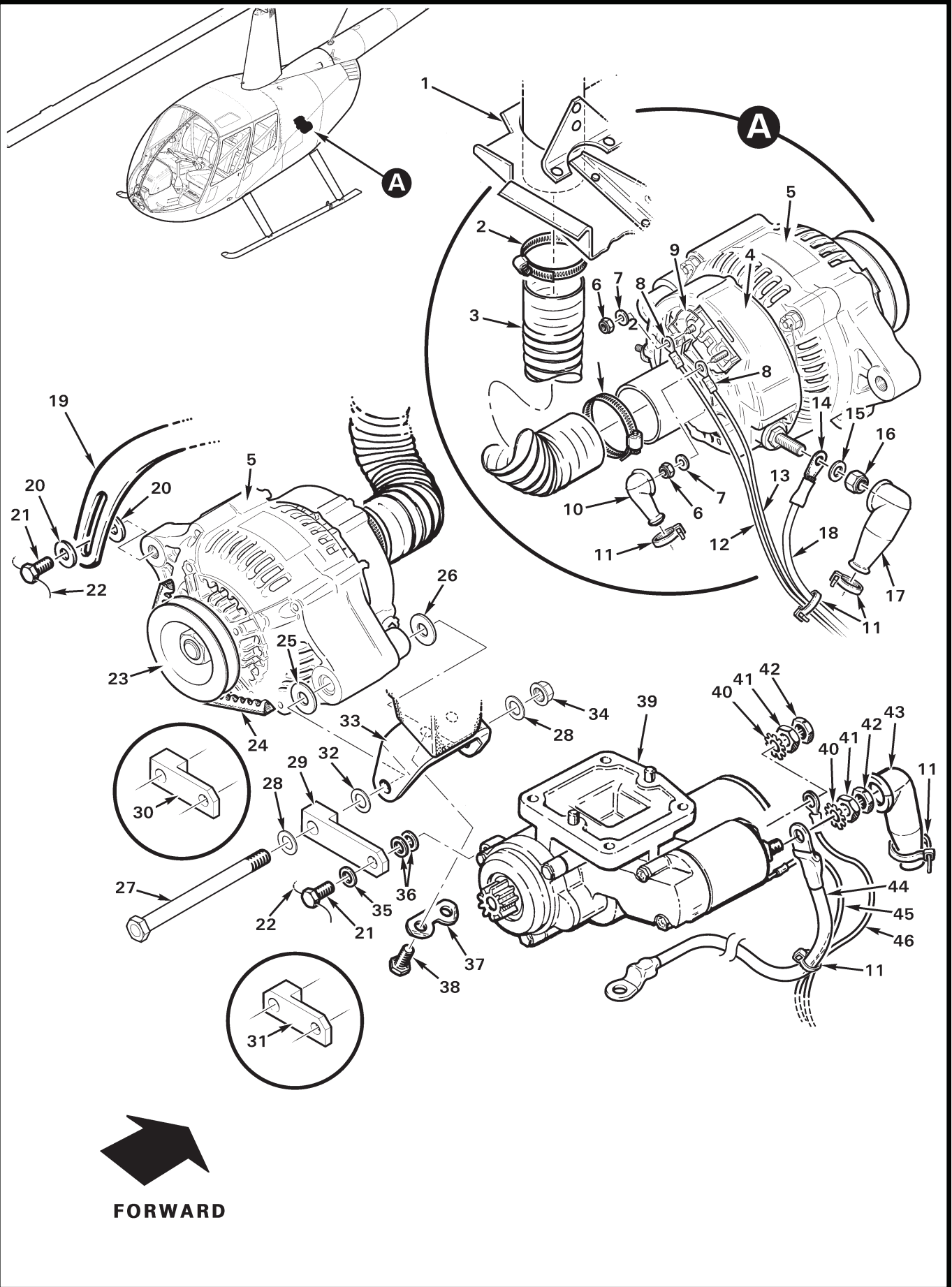

FIGURE AND INDEX NUMBER	PART NUMBER	DESCRIPTION	PARTS AVAIL	QTY PER ASSY
ALTERNATOR AND STARTER INSTALLATION				
71-49B-1	D754-4	Baffle Assembly (O-540 ships)	X	1
	D754-1	Baffle Assembly (IO-540 ships)	X	1
2	B277-24	Clamp	X	2
3	A785-32	Hose (1.5-in. dia., 8.25-in. length; see also Figure 71-39) . . .	X	1
4	—	Shroud Weldment	O	1
5	D748-5*	Alternator Assembly – 70 Amp (14-volt ships; lightweight. Incl items 4, 9, and 23.)	X	1
	D748-6*	Alternator Assembly – 70 Amp (28-volt ships; lightweight. Incl items 4, 9, and 23.)	X	1
6	90576A103	Nut	X	1
7	NAS1149FN816P	Washer	X	1
8	B260-3	Terminal	X	1
9	—	Jumper Wire Assembly	O	1
10	MS25171-1S	Nipple	X	1
11	MS3367-4-9	Ty-Rap	X	A/R
12	C859-23	Wire (Ref)		
13	C859-68	Wire (Ref)		
14	B260-26	Terminal	X	1
15	NAS1149F0432P	Washer	X	1
16	94645A205	Nut	X	1
17	MS25171-2S	Nipple	X	1
18	A780-36	Cable Assembly (aft and tailcone batteries)	X	1
	A780-68	Cable Assembly (under seat battery)	X	1
19	B200-3	Arm	X	1
20	STD-1727**	Washer	X	2
21	NAS6605-5	Bolt	X	2
22	MS20995C32	0.032-in. dia. Safety Wire	X	A/R
23	B200-5	Pulley	X	1
24	B173-6***	V-Belt	X	1
25	STD-690**	Washer	X	1
26	STD-690**	Washer (NAS1149F0632P, NAS1149F0663P, and/or NAS1149F0663P as required to fill gap)	X	A/R

NOTES * RH-24-70 (24V) and RH12-70A (12V) alternators; Hartzell Engine Technologies, formerly Plane Power.
 ** Lycoming part no.
 *** Use with 31M22972* ring gear. Use B173-1 v-belt with 31M21951* ring gear. Continues

FIGURE AND INDEX NUMBER	PART NUMBER	DESCRIPTION	PARTS AVAIL	QTY PER ASSY
ALTERNATOR AND STARTER INSTALLATION (Cont'd)				
71-49B-27	AN6-42A	Bolt	X	1
28	NAS1149F0632P	Washer	X	2
29	B299-3	Link (2.240 inches, center-to-center; for use with Sky-Tech Starters)	X	1
30	B299-1	Link (1.600 inches, center-to-center; for use with B&C Starters)	X	1
31	B299-2	Link (1.530 inches, center-to center; earlier R44s)	X	1
32	NAS1149F0632P	Washer (or NAS1149D0616J as required to fill gap)	X	A/R
33	B200-1	Bracket	X	1
34	D210-7	Nut	X	2
35	STD-35*	Washer	X	1
36	NAS1149F0532P	Washer (or NAS1149F0516P, as required to fill gap)	X	A/R
37	73383*	Lockplate	X	1
38	LW-31-0.94*	Bolt (supplied with engine)	X	2
39	BC315-100-2**	Starter (14-volt ships; includes items 40 and 41.)	X	1
	BC315-100-2R	BC315-100-2** Starter (overhaul exchange)	X	1
	BC315-100-4**	Starter (28-volt ships; includes items 40 and 41.)	X	1
	BC315-100-4R	BC315-100-4** Starter (overhaul exchange)	X	1
40	—	Lockwasher (Ref)		
41	—	Nut (Ref)		
42	B330-16	Palnut (14-volt ships only)	X	2
43	MS25171-2S	Nipple (14-volt aft battery and all 28-volt ships)	X	1
	MS25171-4S	Nipple (14-volt under seat battery, not shown)	X	1
44	A780-65	Cable Assembly (14/28-volt aft battery; 53.5 inches, center-to-center. Includes B274-704 wire, [1] B260-20 and B260-22 terminal, and B158-8 heat shrink.)	X	1
	A780-24	Cable Assembly (28-volt ENG tailcone battery; IO-540 ships. Includes B274-704 wire, [1] B260-20 terminal, and B158-8 heat shrink)	X	1
45	C059-582	Wire (Ref)		
46	B304-20	Fuse Assembly (mates to C859-3115)	X	1

NOTES * Lycoming part no.
 ** B&C Specialty Products part no.

Intentionally Blank

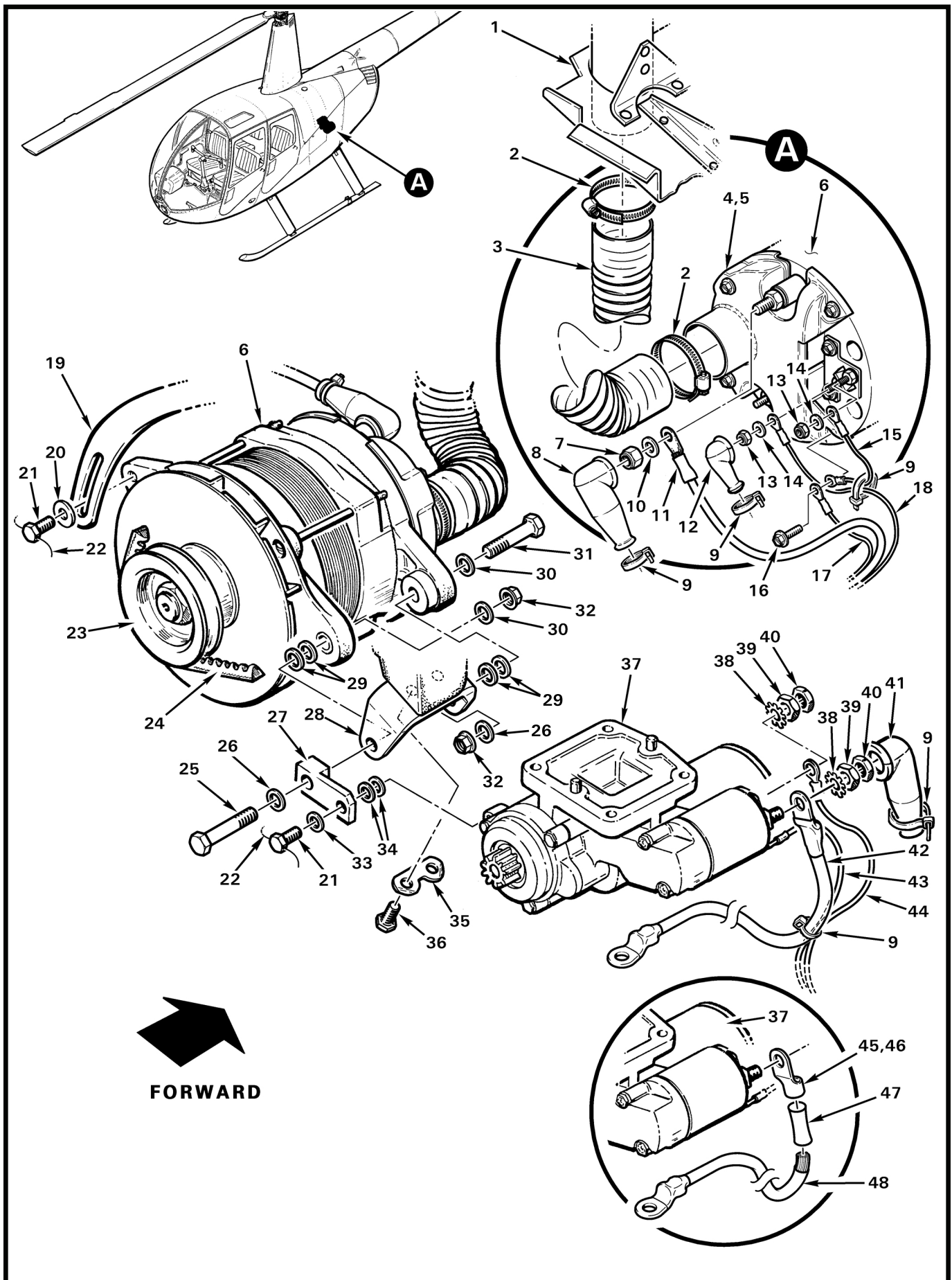

FORWARD

FIGURE AND INDEX NUMBER	PART NUMBER	DESCRIPTION	PARTS AVAIL	QTY PER ASSY
ALTERNATOR AND STARTER INSTALLATION				
71-51-1	D754-4	Baffle Assembly (O-540 ships)	X	1
	D754-1	Baffle Assembly (IO-540 ships)	X	1
2	B277-24	Clamp	X	2
3	A785-32	Hose (1.5 in. dia., 8.25 in. length; also see Figure 71-39)	X	1
4	D747-5	Shroud Weldment (install using item 5)	X	1
5	B270-20	Adhesive	X	A/R
6	D748-2	Alternator Assembly, 70-Amp (14-volt ships. Incl items 4, 5, 7, 10, 13, 14, and 23.)	X	1
	D748-2R	D748-2 Alternator Assembly (overhaul exchange)	X	1
	D748-1	Alternator Assembly, 70-Amp (28-volt ships. Incl items 4, 5, 7, 10, 13, 14, and 23.)	X	1
	D748-1R	D748-1 Alternator Assembly (overhaul exchange)	X	1
7	MS21044N4	Nut	X	1
8	MS25171-2S	Nipple	X	2
9	MS3367-4-9	Ty-Rap	X	3
10	NAS1149F0432P	Washer	X	1
11	A780-36	Cable Assembly (aft and tailcone battery)	X	1
	A780-37	Cable Assembly (forward and under seat battery)	X	1
12	MS25171-1S	Nipple	X	1
13	MS21044N06	Nut	X	2
14	NAS1149FN616P	Washer	X	2
15	C059-24	Wire (Ref)		
16	—	Screw (supplied with alternator)	O	4
17	C059-33	Wire (Ref)		
18	C059-23	Wire (Ref)		
19	B200-3	Arm	X	1
20	STD-1727*	Washer	X	1
21	LW-31H0.75*	Bolt (Ref; supplied with engine)		
22	MS20995C32	0.032 in. dia. Safety Wire	X	A/R
23	36B19484*	Pulley	X	1
24	B173-3**	V-Belt	X	1

NOTES * Lycoming part no.
 ** Use with 31M22972* ring gear. Use B173-1 v-belt with 31M21951* ring gear.

Continues

FIGURE AND INDEX NUMBER	PART NUMBER	DESCRIPTION	PARTS AVAIL	QTY PER ASSY
ALTERNATOR AND STARTER INSTALLATION (Cont'd)				
71-51-25	AN6-17A	Bolt (AN6-16A or AN6-20A may be used to obtain 2-4 threads beyond nut.)	X	1
26	NAS1149F0632P	Washer	X	4
27	B299-1	Link (1.600 inch center-to-center)	X	1
	B299-2	Link (1.530 inch center-to-center)	X	1
28	B200-1	Bracket	X	1
29	NAS1149F0663P	Washer (NAS1149F0632P or NAS1149D0616J as required for shimming; IO-540 ships only)	X	A/R
	STD-690*	Washer (76534* shim, as required for shimming; O-540 ships only)	X	A/R
30	NAS1149F0632P	Washer (IO-540 ships only)	X	2
	STD-690*	Washer (O-540 ships only)	X	2
31	AN6-15A	Bolt	X	1
32	MS21042L6	Nut	X	2
33	STD-35*	Washer	X	1
34	NAS1149F0532P	Washer (or NAS1149F0516P, as required for shimming)	X	A/R
35	73383*	Lockplate	X	1
36	LW-31-0.94*	Bolt (supplied with engine)	X	2
37	BC315-100-2**	Starter (14-volt ships. Includes items 38 and 39.)	X	1
	BC315-100-2R	BC315-100-2** Starter (overhaul exchange)	X	1
	BC315-100-4**	Starter (28-volt ships. Includes items 38 and 39.)	X	1
	BC315-100-4R	BC315-100-4** Starter (overhaul exchange)	X	1
38	—	Lockwasher (Ref)		
39	—	Nut (Ref)		
40	B330-16	Palnut (14-volt ships only)	X	2
41	MS25171-2S	Nipple (14-volt aft battery and all 28-volt ships)	X	1
	MS25171-4S	Nipple (14-volt forward/under seat battery not shown)	X	1
42	A780-26	Cable Assembly (14/28-volt aft battery [O-540 ships])	X	1
	A780-24	Cable Assembly (28-volt ENG tailcone battery [O-540 ships])	X	1
	A780-39	Cable Assembly (28-volt aft, ENG/Police tailcone battery [IO-540 ships])	X	1
43	C059-582	Wire (Ref)		

NOTES * Lycoming part no.
 ** B&C Specialty Products part no.

Continues

FIGURE AND INDEX NUMBER	PART NUMBER	DESCRIPTION	PARTS AVAIL	QTY PER ASSY
ALTERNATOR AND STARTER INSTALLATION (Cont'd)				
71-51-44	C059-591	Wire (Ref; O-540 ships)		
	C059-1602	Wire (Ref; IO-540 ships)		
45	B260-23	Terminal	X	2
46	B260-20	Terminal	X	2
47	B158-8	Heat Shrink	X	A/R
48	C067-587	Wire (Ref; 14-volt forward/under seat battery; includes items 45 [1] and 47)	X	1
	C067-1386	Wire (Ref; 28-volt forward/under seat battery; includes items 46 [1] and 47)	X	1
NOTES				

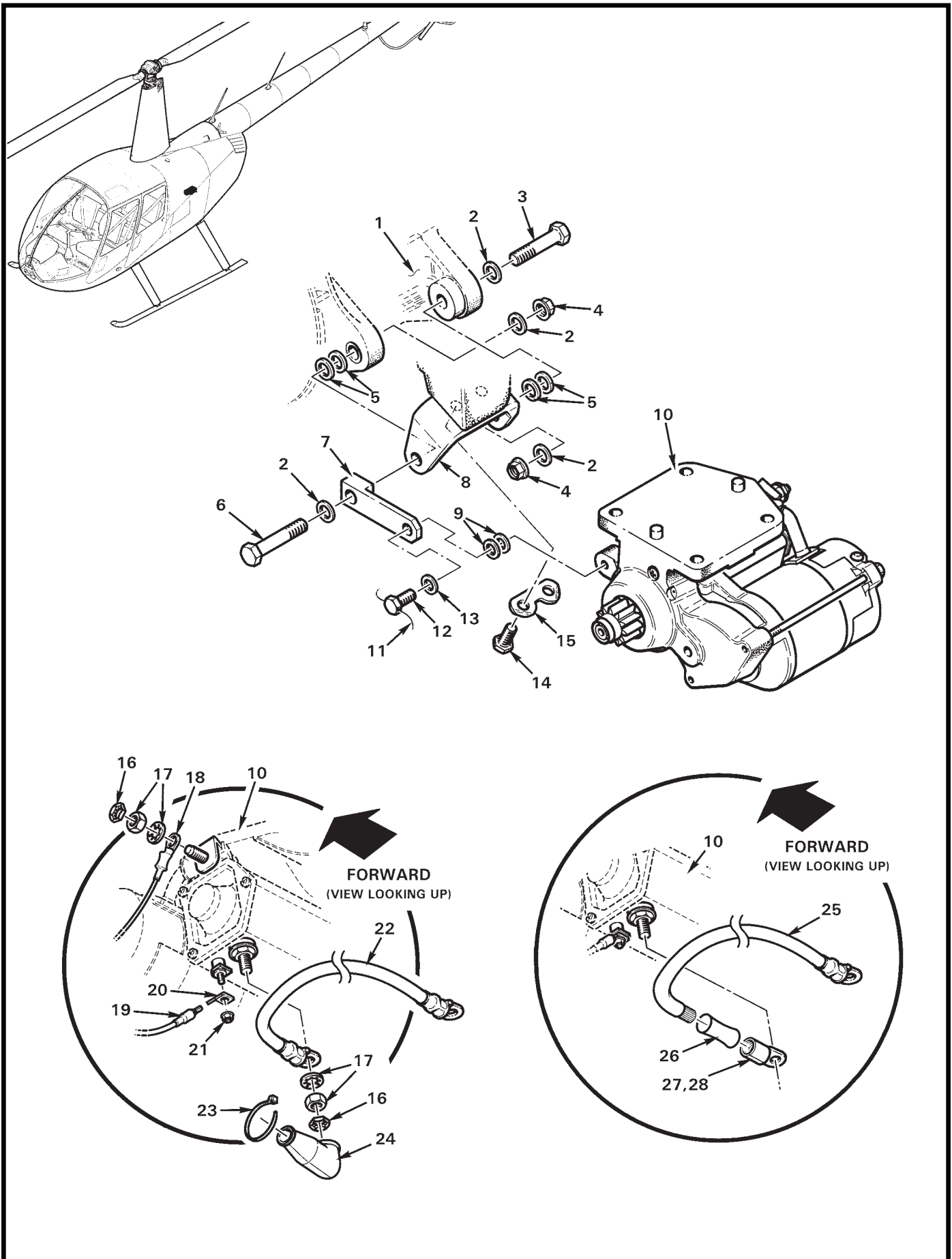

FIGURE AND INDEX NUMBER	PART NUMBER	DESCRIPTION	PARTS AVAIL	QTY PER ASSY
STARTER INSTALLATION				
71-55-1	D748	Alternator Assy (Ref; see Figure 71-51)		
2	NAS1149F0632P	Washer	X	4
3	AN6-15A	Bolt	X	1
4	MS21042L6	Nut	X	2
5	NAS1149F0663P	Washer (NAS1149F0632P, NAS1149D0616J as required for shimming)	X	A/R
6	AN6-17A	Bolt (AN6-16A or AN6-20A may be used to obtain 2-4 threads beyond nut)	X	1
7	B299-3	Link	X	1
8	B200-1	Bracket	X	1
9	NAS1149F0532P	Washer (or NAS1149F0516P as required for shimming)	X	A/R
10	149-12HT/H*	Starter (14-volt ships. Includes items 17, 20, and 21.)	O	1
	149-24HT/H*	Starter (28-volt ships. Includes items 17, 20, and 21.)	O	1
11	MS20995C32	0.032 in. dia. Safety Wire	X	A/R
12	LW-31H0.75**	Bolt (Ref; supplied with engine)		
13	STD-35**	Washer	X	1
14	LW-31-0.94**	Bolt	X	1
15	73383**	Lockplate	X	1
16	B330-16	Palnut	X	2
17	—	Washer and Nut (Ref, supplied with starter)		
18	C059-591	Wire (Ref; O-540 ships. C059-1602, IO-540 ships)		
19	C059-582	Wire (Ref)		
20	—	Terminal (Ref)		
21	—	Nut (Ref)		
22	A780-26	Cable Assy (14/28-volt aft battery [O-540 ships])	X	1
	A780-24	Cable Assy (28-volt ENG tailcone battery [O-540 ships])	X	1
	A780-39	Cable Assy (28-volt, ENG/Police tailcone battery [IO-540 ships])	X	1
23	MS3367-4-9	Ty-Rap	X	3
24	MS25171-2S	Nipple (14-volt aft battery and all 28-volt ships)	X	1
	MS25171-4S	Nipple (14-volt forward/under seat battery; not shown)	X	1
25	C067-587	Wire (14-volt forward/under seat battery; incl item 27 [1])	X	1
	C067-1386	Wire (28-volt forward/under seat battery; incl item 28 [1])	X	1

NOTES * Sky-Tec part no.
 ** Lycoming part no.

Continues

FIGURE AND INDEX NUMBER	PART NUMBER	DESCRIPTION	PARTS AVAIL	QTY PER ASSY
STARTER INSTALLATION (Cont'd)				
71-55-26	B158-8	Heat Shrink	X	A/R
27	B260-23	Terminal (for C067-587 wire)	X	2
28	B260-20	Terminal (for C067-1386 wire)	X	2

NOTES

Intentionally Blank

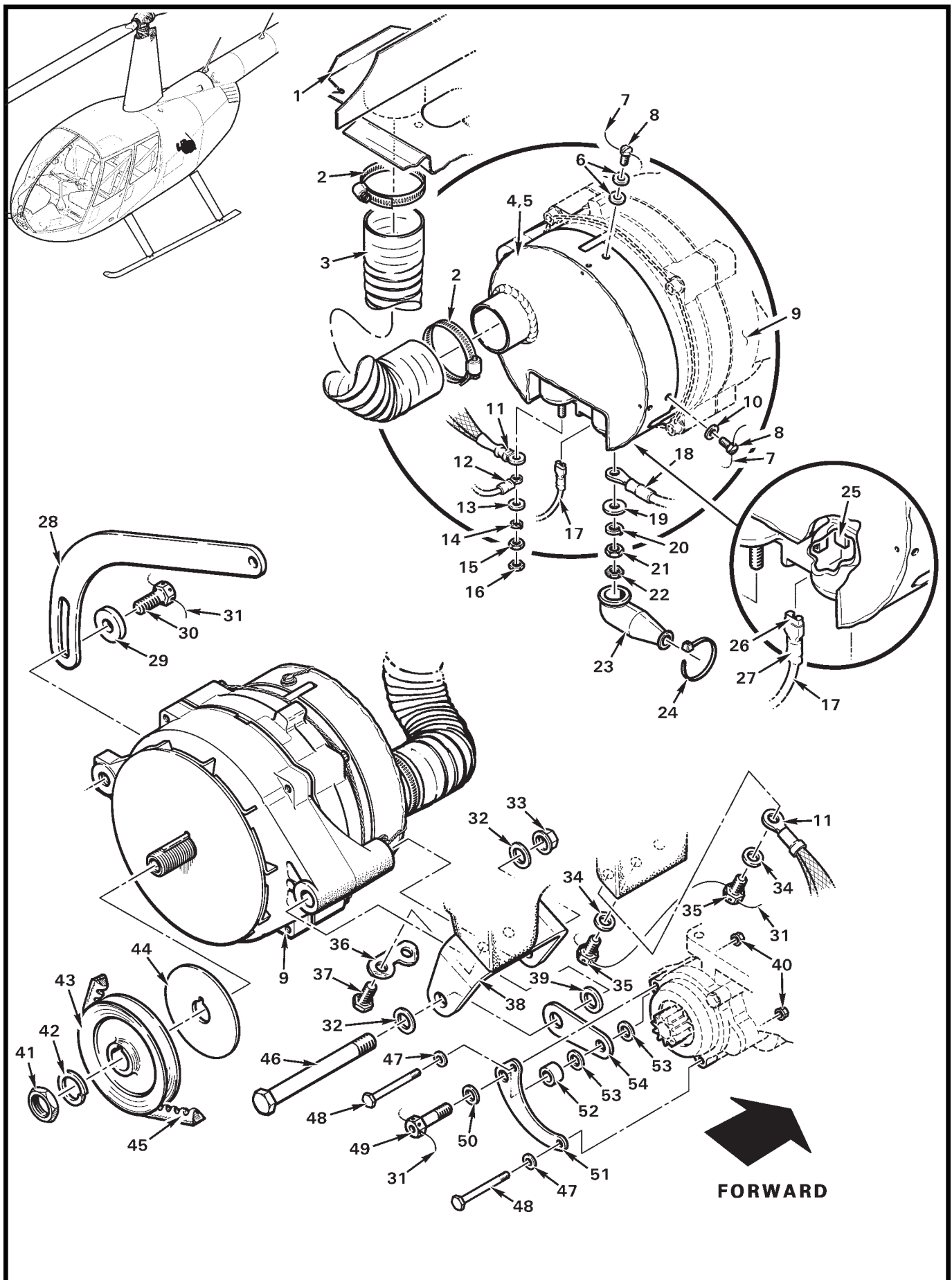

FIGURE AND INDEX NUMBER	PART NUMBER	DESCRIPTION	PARTS AVAIL	QTY PER ASSY
130-AMP 28V ALTERNATOR INSTALLATION				
71-59-1	D754-1	Baffle Assembly	X	1
2	B277-24	Clamp	X	2
3	A785-32	Hose (1.5 inch dia., 8.25 inch length)	X	1
4	D726-1	Shroud Weldment (Used with item 39 [D729-1; O-540], for spares; not shown.)	X	1
5	D726-8	Shroud Weldment (Used with item 39 [D729-2; IO-540], for spares; not shown.)	X	1
6	NAS1149F0363P	Washer	X	2
7	MS20995C20	0.020 in. dia. Safety Wire	X	A/R
8	AN503-10-6	Screw	X	3
9	D729-2	Alternator Assembly – 130-Amp (28-volt; IO-540 ships. Includes items 5, 7, 8, 10, 13 thru 16, 19 thru 22, 25, and 41 thru 44.)	X	1
	D729-1	Alternator Assembly - 130-Amp (28-volt; O-540 ships. Includes items 4, 7, 8, 10, 13 thru 16, 19 thru 22, 25, and 41 thru 44.)	X	1
10	NAS1149F0332P	Washer	X	2
11	A780-38	Cable Assembly (ground)	X	1
12	C059-33	Wire (Ref)		
13	—	Flat Washer	O	1
14	—	Lockwasher	O	1
15	—	Nut	O	1
16	B330-8	Palnut	X	1
17	C059-23	Wire (Ref)		
18	A780-36	Cable Assembly (aft and tailcone battery)	X	1
	A780-37	Cable Assembly (forward and under seat battery)	X	1
19	—	Flat Washer	O	1
20	—	Lockwasher	O	1
21	—	Nut	O	1
22	B330-12	Palnut	X	1
23	MS25171-2S	Nipple	X	1
24	MS3367-4-9	Ty-Rap	X	1
25	—	Terminal (“FLD”; Ref)		

NOTES

Continues

FIGURE AND INDEX NUMBER	PART NUMBER	DESCRIPTION	PARTS AVAIL	QTY PER ASSY
130-AMP 28V ALTERNATOR INSTALLATION (Cont'd)				
71-59-26	B262-4	Receptacle	X	1
27	B158-4	Heat Shrink	X	A/R
28	D728-1	Arm	X	1
29	A141-9	Washer	X	1
30	MS20074-06-07	Bolt	X	1
31	MS20995C32	0.032 in. dia. Safety Wire	X	A/R
32	NAS1149F0732P	Washer	X	2
33	NAS1291-7	Nut	X	1
34	NAS1149F0563P	Washer	X	2
35	MS20074-05-04	Bolt	X	2
36	73383*	Lockplate	X	1
37	LW-31-0.94*	Bolt	X	2
38	D728-3	Bracket	X	1
39	NAS1149F0763P	Washer	X	1
40	—	Nut (Ref; supplied with starter)	O	3
41	—**	Nut	O	1
42	—**	Lockwasher	O	1
43	D727-1	Pulley	X	1
44	D728-2	Spacer	X	1
45	B173-2	V-Belt	X	1
46	AN7-40A	Bolt	X	1
47	—	Washer (Ref; supplied with starter)	O	3
48	NAS6603-25	Bolt	X	2
49	MS20074-05-11	Bolt	X	1
50	NAS1149F0532P	Washer	X	1
51	D728-6	Plate	X	1
52	C130-42	Spacer	X	1
53	NAS1149F0532P	Washer	X	A/R
54	D728-5	Link	X	1

NOTES * Lycoming part no.
 ** Items 41 and 42 may be obtained from Kelly Aerospace as part no. 90-33.

Intentionally Blank

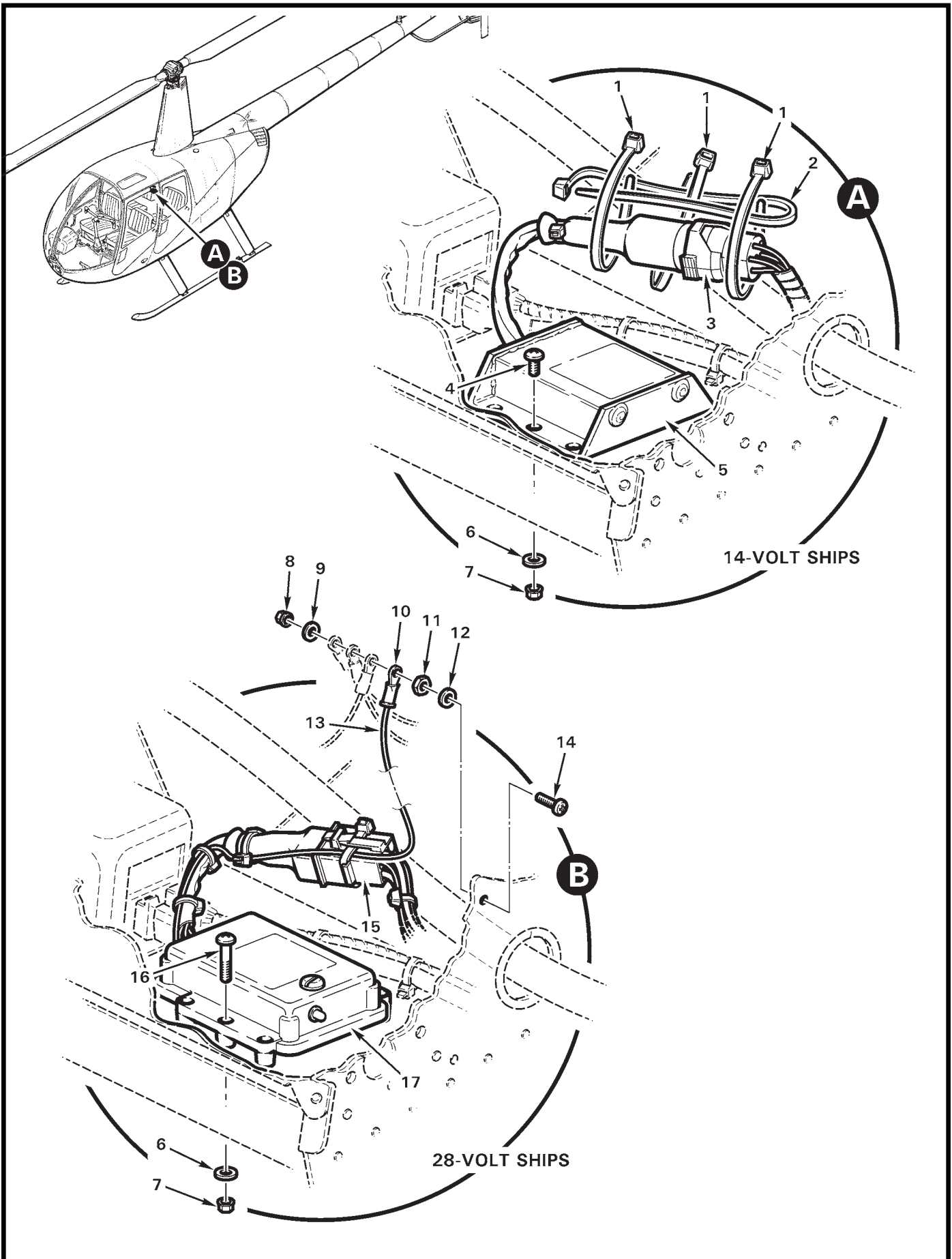

FIGURE AND INDEX NUMBER	PART NUMBER	DESCRIPTION	PARTS AVAIL	QTY PER ASSY
ALTERNATOR CONTROL UNIT INSTALLATION				
71-63-1	MS3367-5-9	Ty-Rap	X	3
2	MS3367-7-9	Ty-Rap	X	1
3	B264-23	Housing	X	1
	B264-2	Socket	X	2
	B264-4	Socket	X	3
4	MS27039C1-06	Screw	X	2
5	A942-3	Alternator Control Unit (14-volt ships; includes housing)	X	1
6	NAS1149F0332P	Washer	X	2
7	MS21042L3	Nut	X	2
8	MS21042L08	Nut	X	1
9	NAS1149FN816P	Washer	X	1
10	—	Terminal – Stud (no. 8)	O	1
11	B301-8	Nut (Brass)	X	1
12	NAS1149DN832H	Washer	X	1
13	—	Wire (ground; Ref)		
14	AN515UB8R10	Screw	X	1
15	B263-19	Housing	X	1
	B263-2	Socket	X	2
	B263-4	Socket	X	3
16	MS27039C1-14	Screw	X	1
17	A942-4	Alternator Control Unit (28-volt ships; includes items 10, 13, and housing)	X	1

NOTES

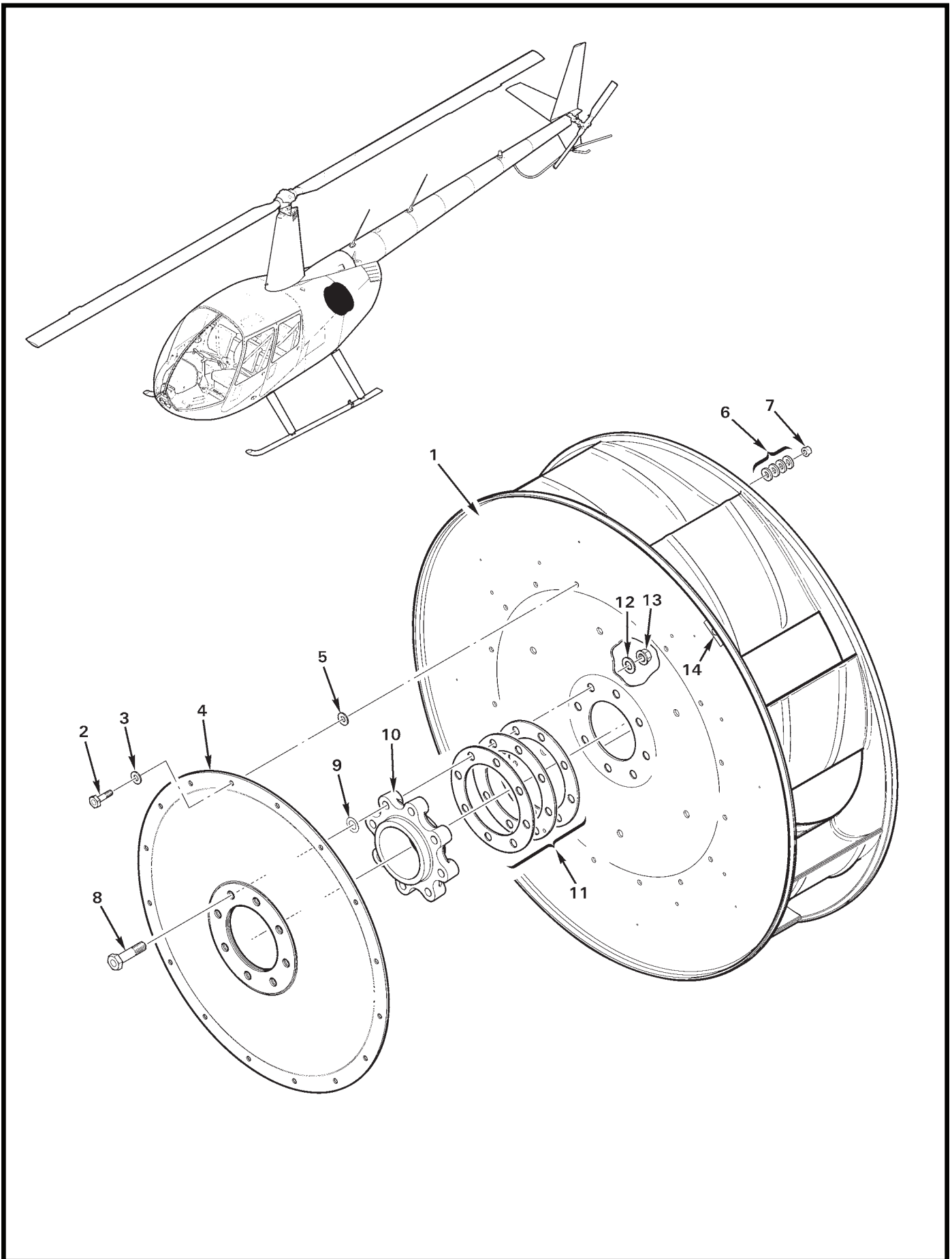

FIGURE AND INDEX NUMBER	PART NUMBER	DESCRIPTION	PARTS AVAIL	QTY PER ASSY
D174 FANWHEEL ASSEMBLY				
71-65-1	D174-2*	Fanwheel Assembly (Incl items 2 thru 14)	X	1
2	NAS6603-6	Bolt	X	16
3	NAS1149F0332P	Washer	X	16
4	C187-3	Cone Assembly	O	1
5	NAS1149F0316P	Washer	X	16
6	NAS1149D0363J**	Washer	X	64
7	MS21042L3	Nut	X	16
8	NAS6605-12	Bolt (or NAS6605-13 or -14 as required for proper thread engagement)	X	8
9	NAS1149C0516R	Washer	X	8
10	C186-1	Hub	X	1
11	C178-2	Spacer (one, two, or three required for shimming)	X	A/R
12	NAS1149F0532P	Washer	X	8
13	MS21042L5	Nut	X	8
14	NAS620-5	Washer (Ref; installed for balance)		
	B171-1	Weight (Ref; or B171-2 thru B171-6 as required for balance)		

NOTES * Must be used with C007-5 shaft and bearing assembly; incompatible with C007-3 or C007-4.
 ** See R44 MM § 6.240 for fan dynamic balance procedure.

Intentionally Blank

CHAPTER 76
ENGINE CONTROLS

<i>Figure</i>	<i>Title</i>	<i>Page</i>
76-1	Throttle Control Installation	76.0
76-5	Throttle Control Installation	76.4
76-9	Carb Heat and Mixture Controls	76.8
76-13	Carb Heat Assist Installation	76.12
76-17	Mixture Control Installation	76.16

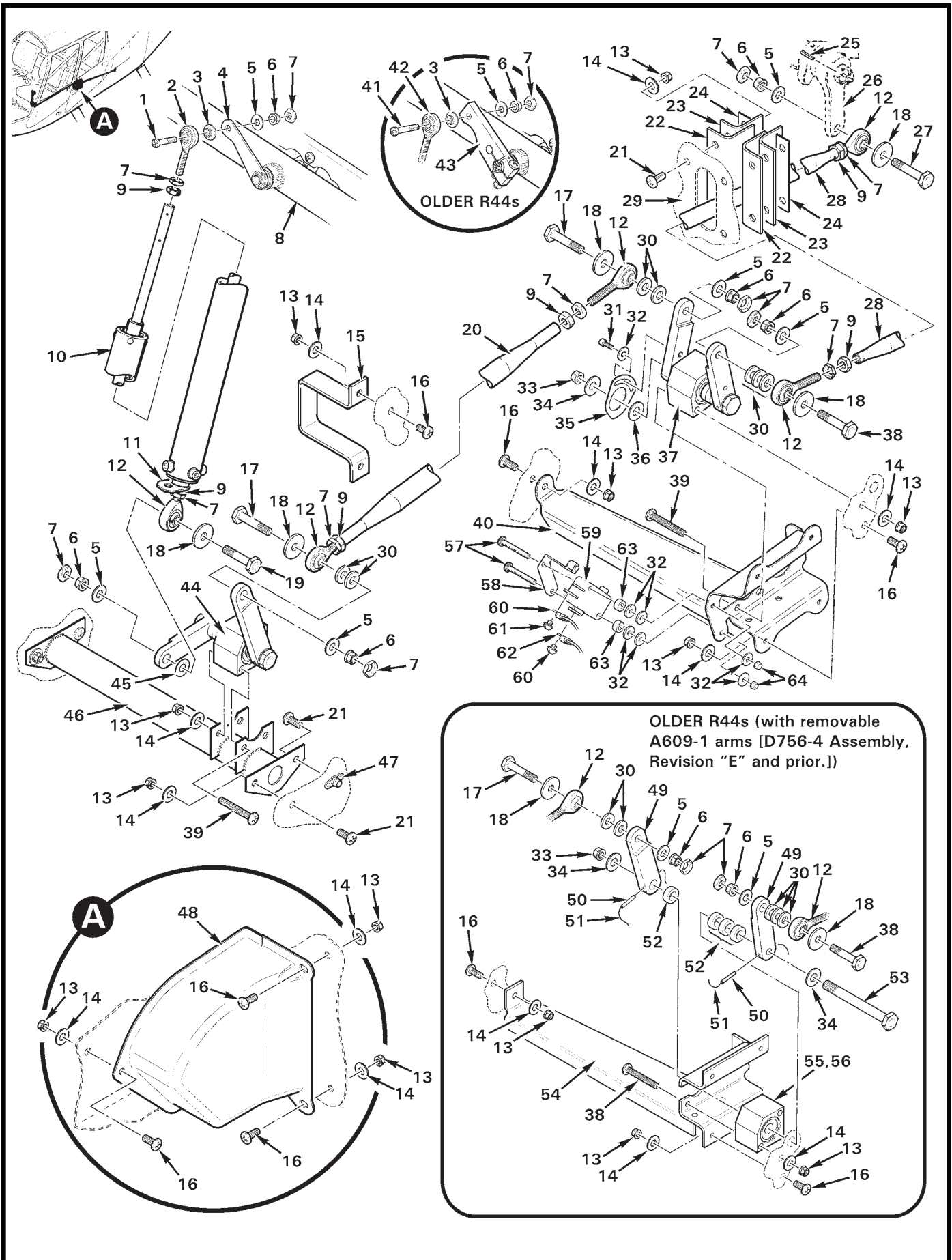

FIGURE AND INDEX NUMBER	PART NUMBER	DESCRIPTION	PARTS AVAIL	QTY PER ASSY
THROTTLE CONTROL INSTALLATION*				
76-1-1	A486-4	Screw	X	1
2	A127-3	Rod End	X	1
3	A341-1	Spacer	X	1
4	C341-3	Arm Weldment (Ref)		
5	NAS1149F0332P	Washer	X	6
6	D210-3	Nut	X	6
7	B330-7	Palnut	X	7
8	C758-1	Collective Assembly (Ref)		
9	AN315-3R	Nut	X	2
10	A327-1	Overtravel Spring Assembly (Incl items 2, 7, 9, 11, and 12) . .	X	1
11	A697-2	Plate (Ref)		
12	A933-3	Rod End	X	4
13	MS21042L08	Nut	X	22
14	NAS1149FN816P	Washer	X	22
15	C737-1	Restraint	X	1
16	MS27039C0805	Screw	X	2
17	NAS6603-10	Bolt	X	2
18	A141-17	Washer	X	5
19	NAS6603-8	Bolt	X	1
20	C121-21	Push-Pull Tube Assembly (Incl items 7, 9, and 12)	X	1
21	MS27039C0806	Screw	X	15
22	A595-2	Seal (white)	X	2
23	A595-1	Seal (black)	X	2
24	A597-1	Cover	X	2
25	MS24665-132	Cotter Pin	X	1
26	—	Arm – Carburetor (Ref)		
27	NAS6603-9	Bolt	X	1
28	C336-1	Push-Pull Tube	X	1
29	NAS1149F0363P	Washer	X	7
30	C233-1	Firewall – Vertical (Ref)		
31	91251A107	Screw	X	1

NOTES * Ship S/N 0001 thru 9999.

Continues

FIGURE AND INDEX NUMBER	PART NUMBER	DESCRIPTION	PARTS AVAIL	QTY PER ASSY
THROTTLE CONTROL INSTALLATION* (Cont'd)				
76-1-32	NAS1149FN432P	Washer	X	7
33	MS21042L4	Nut	X	1
34	NAS1149F0432P	Washer	X	2
35	A607-2	Cam	X	1
36	NAS620-416L	Washer	X	1
37	D756-4	Bellcrank Assembly – Aft	X	1
38	NAS6603-11	Bolt	X	1
39	MS27039C0818	Screw	X	7
40	C607-1	Support (Revision “E” and subsequent)	X	1
41	A486-1**	Screw	X	1
42	A759-1	Rod End	X	1
43	C342-1**	Arm	X	1
44	D756-3	Bellcrank Assembly – Forward	X	1
45	NAS1149D0316J	Washer	X	1
46	C608-1	Support	X	1
47	MS21069L08	Nutplate	X	2
48	C606-5	Cover (clear; earlier covers were black)	X	1
49	A609-1	Arm (Ref)		
50	MS16562-15	Roll Pin	O	2
51	MS20995C32	0.032 in. dia. Safety Wire	X	A/R
52	A130-29	Spacer	O	4
53	NAS6604-31	Bolt	X	1
54	C607-1**	Support Assembly (Ref; Revision “D” and prior. Used with item 56.)		
55	A605-1	Housing	O	1
	C647-17	Bearing	O	1
56	D756-4**	Bellcrank Assembly – Aft (Ref; Revision “E” and prior. Used with item 54.)		
57	MS35206-220	Screw	X	2
58	JV-5	Actuator	X	1
59	V3-1	Switch (full throttle light; includes item 60)	X	1
60	—	Screw (includes lockwasher)	O	2

NOTES * Ship S/N 0001 thru 9999.
 ** Installed on earlier R44s.

Continues

FIGURE AND INDEX NUMBER	PART NUMBER	DESCRIPTION	PARTS AVAIL	QTY PER ASSY
THROTTLE CONTROL INSTALLATION* (Cont'd)				
76-1-61	C859-2488	Wire (Ref)		
	B260-1	Terminal	X	1
62	C859-2487	Wire (Ref)		
	B260-1	Terminal	X	1
63	A130-14	Spacer	X	2
64	MS21042L04	Nut	X	2

NOTES * Ship S/N 0001 thru 9999.

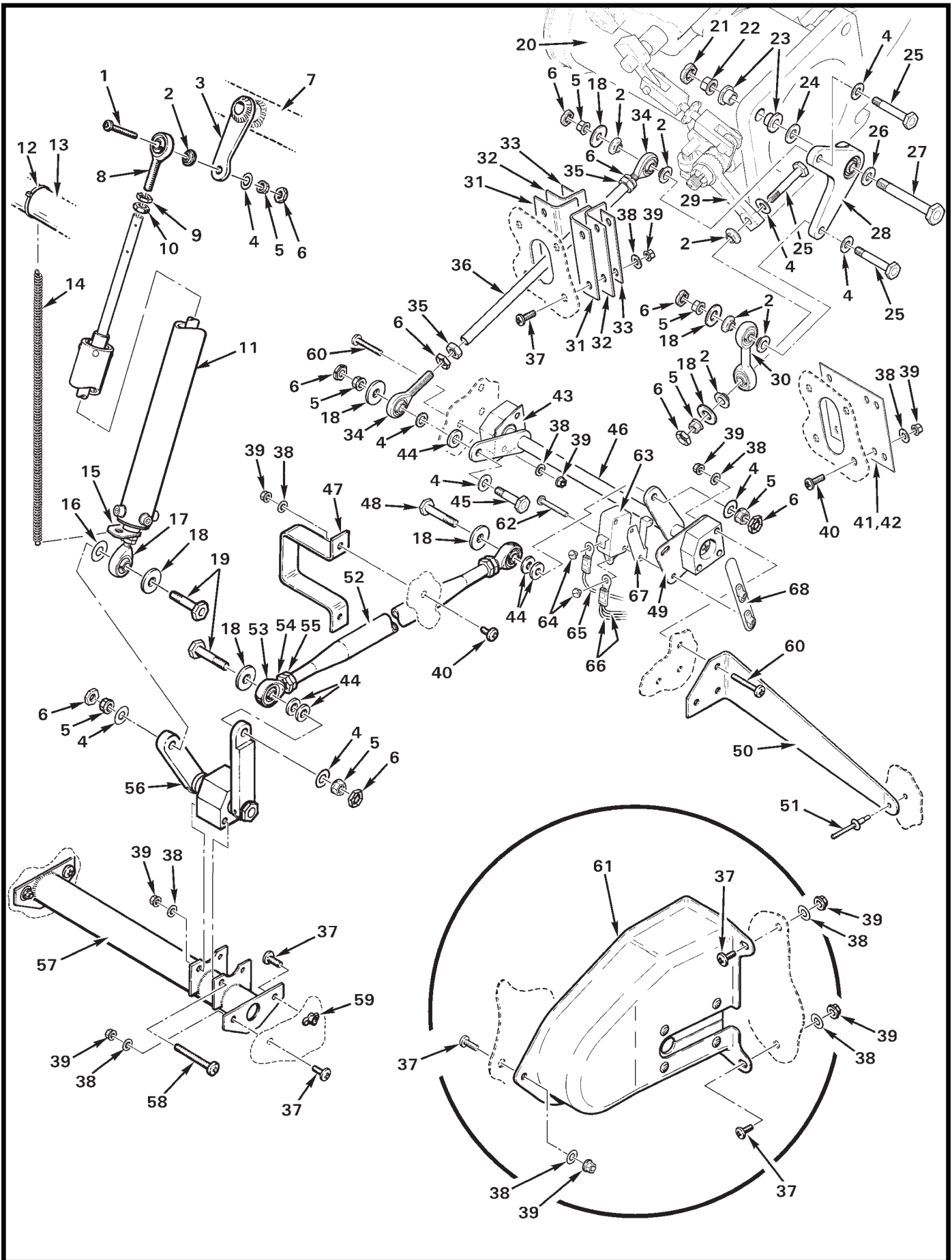

FIGURE AND INDEX NUMBER	PART NUMBER	DESCRIPTION	PARTS AVAIL	QTY PER ASSY
THROTTLE CONTROL INSTALLATION*				
76-5-1	A486-4	Screw	X	1
2	A341-1	Spacer	X	7
3	C341-1	Arm Assembly (Ref)		
4	NAS1149F0332P	Washer	X	8
5	D210-3	Nut	X	8
6	B330-7	Palnut	X	10
7	C758-3	Collective Stick Assembly (Ref)		
8	A127-3	Rod End	X	1
9	B330-7	Palnut	X	2
10	AN315-3R	Nut	X	2
11	A327-1	Overtravel Spring Assembly (Incl items 8 thru 10, 15, and 17) . .	X	1
12	MS3367-4-9	Ty-Rap	X	1
13	C348-1	Anchor (Ref)		
14	B774-2	Spring	X	1
15	A697-2	Plate (Ref)		
16	NAS1149D0316J	Washer	X	1
17	A933-3	Rod End	X	1
18	A141-17	Washer	X	7
19	NAS6603-10	Bolt	X	2
20	2576630-4**	Fuel Control (Ref, see Figure 28-1)		
21	B330-13	Palnut	X	1
22	D210-4	Nut	X	1
23	D543-2	Spacer	X	2
24	NAS1149F0463P	Washer	X	1
25	NAS6603-13	Bolt	X	3
26	NAS1149F0432P	Washer	X	1
27	NAS6604-22	Bolt	X	1
28	D731-9	Bellcrank Assembly	X	1
29	—	Arm – Fuel Control (Ref)		
30	B564-2	Link	X	1
31	A595-2	Seal (white)	X	2
32	A595-1	Seal (black)	X	2
33	A597-1	Cover	X	2
34	A127-3	Rod End	X	2
35	AN315-3R	Nut	X	2

NOTES * Ship S/N 10001 and subsequent.
 ** Avstar Fuel Systems part no.

Continues

FIGURE AND INDEX NUMBER	PART NUMBER	DESCRIPTION	PARTS AVAIL	QTY PER ASSY
THROTTLE CONTROL INSTALLATION* (Cont'd)				
76-5-36	A336-6	Push-Pull Tube (6.25-inch length)	X	1
	A336-9	Push-Pull Tube (5.90-inch length)	X	1
37	MS27039C0806	Screw	X	12
38	NAS1149FN816P	Washer	X	23
39	MS21042L08	Nut	X	23
40	MS27039C0805	Screw	X	6
41	D731-6	Cover	X	1
42	B270-1	Sealant (2-oz tube)	X	A/R
43	D731-5	Retainer (Ref)		
44	NAS1149F0363P	Washer	X	5
45	NAS6603-8	Bolt	X	2
46	D731-1	Bellcrank Assembly	X	1
47	C737-1	Restraint	X	1
48	NAS6603-9	Bolt	X	1
49	D731-8	Retainer (Ref)		
50	D731-7	Strut	X	1
51	NAS9301B-4-02	Rivet	X	1
52	C121-21	Push-Pull Tube Assembly (Incl items 53 thru 55)	X	1
53	A933-3	Rod End	X	2
54	B330-7	Palnut	X	2
55	AN315-3R	Nut	X	2
56	D756-1	Bellcrank Assembly	X	1
57	C608-1	Support Weldment	X	1
58	MS27039C0818	Screw	X	2
59	MS21069L08	Nutplate (Ref)		
60	MS27039C0813	Screw	X	6
61	C606-2	Cover Assembly (Rev. K and subsequent [clear], Rev. J and prior [black])	X	1
62	MS35206-219	Screw	X	2
63	V3-1	Switch (full throttle light; includes item 64)	X	1
64	—	Screw (includes lockwasher)	O	2
65	C859-2487	Wire (Ref)		
	B260-1	Terminal	X	1

NOTES * Ship S/N 10001 and subsequent.

Continues

FIGURE AND INDEX NUMBER	PART NUMBER	DESCRIPTION	PARTS AVAIL	QTY PER ASSY
THROTTLE CONTROL INSTALLATION* (Cont'd)				
76-5-66	C859-2488	Wire (Ref)		
	C859-2490	Wire (Ref)		
	B260-1	Terminal	X	1
67	JV-5	Actuator	X	1
68	D731-11	Plate Assembly	X	1

NOTES * Ship S/N 10001 and subsequent.

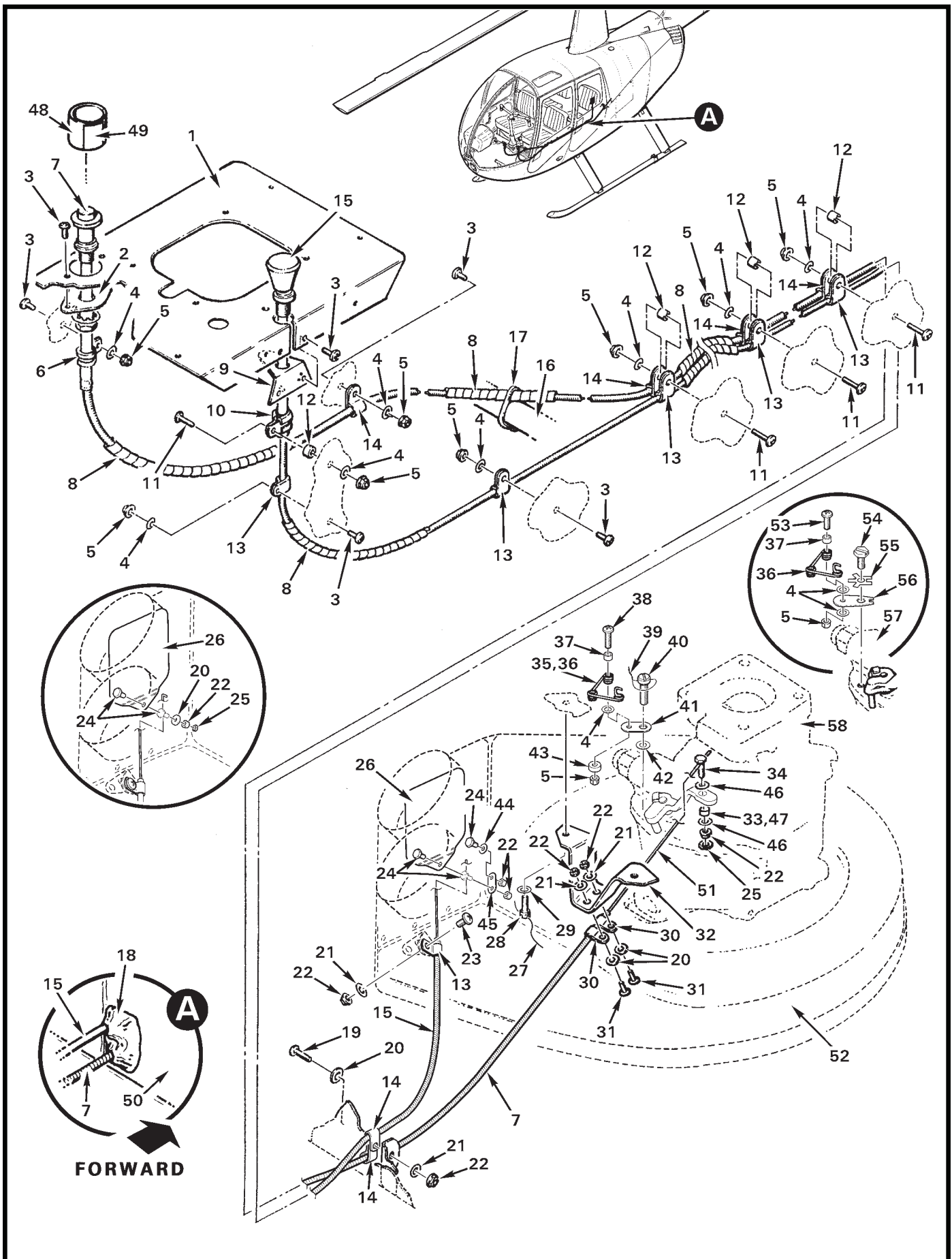

FIGURE AND INDEX NUMBER	PART NUMBER	DESCRIPTION	PARTS AVAIL	QTY PER ASSY
		CARB HEAT AND MIXTURE CONTROLS		
76-9-1	C444-1	Cover Assembly (Ref, see Figure 67-1)		
2	A518-2	Cover Assembly	X	1
3	MS27039C0806	Screw	X	9
4	NAS1149FN816P	Washer	X	9
5	MS21042L08	Nut	X	9
6	MS21919WDG6	Clamp	X	1
7	A522-7	Control – Mixture (Incl item 51)	X	1
8	B161-4	Spirap	X	A/R
9	C518-1	Cover Assembly	X	1
10	MS21919WDG4	Clamp	X	1
11	MS27039C0809	Screw	X	4
12	A130-21	Spacer	X	4
13	AN742-3	Clamp	X	7
14	AN742-4	Clamp	X	5
15	A522-6	Control – Carb Heat (ship S/N 0001 thru 0201)	X	1
16	C608-1	Support (Ref; see Figure 76-1)		
17	MS3367-7-9	Ty-Rap	X	1
18	B270-5	Sealant (White, 7.5-oz tube; also used around wire harness at firewall [not shown])	X	A/R
19	MS27039C1-08	Screw	X	1
20	NAS1149F0363P	Washer	X	4
21	NAS1149F0332P	Washer	X	4
22	D210-3	Nut	X	7
23	MS27039C1-06	Screw	X	1
24	A462-1	Fitting	X	2
25	B330-7	Palnut	X	2
26	C562-1	Slider Valve	X	1
27	MS20995C32	0.032 in. dia. Safety Wire	X	A/R
28	NAS1352-4H6P	Screw	X	2
29	NAS1149F0432P	Washer	X	2
30	AN735-4	Clamp	X	2
31	MS27039C1-07	Screw	X	2

NOTES

Continues

FIGURE AND INDEX NUMBER	PART NUMBER	DESCRIPTION	PARTS AVAIL	QTY PER ASSY
CARB HEAT AND MIXTURE CONTROLS (Cont'd)				
76-9-32	C577-2	Bracket	X	1
33	A130-48	Spacer	X	1
34	A462-4	Fitting	X	1
35	C071-1	Spring Assembly (Incl items 4 [1], 5 [1], 36 thru 38, 41, and 43)	X	1
36	A930-1	Spring	X	1
37	A130-13	Spacer	X	1
38	MS27039C0810	Screw	X	1
39	MS20995C20	0.020 in. dia. Safety Wire	X	A/R
40	AV15-B98*	Screw (supplied with item 58)	O	1
41	C071-3	Bracket	X	1
42	—	Washer (supplied with item 58)	O	1
43	A130-37	Spacer	X	1
44	NAS1149F0316P	Washer	X	1
45	A696-3	Plate	X	1
46	NAS1149E0363R	Washer	X	2
47	A257-1	Grease	X	A/R
48	A950-1	Guard – Mixture Control (Incl item 49)	X	1
49	A654-45	Decal	X	1
50	—	Firewall (Ref)		
51	A-641R1	Inner Wire	X	1
52	C057-5	Air Box Assembly (Ref, see Figure 71-13)		
53	MS27039C0807	Screw	X	1
54	AV15-B126	Screw (Ref; used with item 57)		
55	AV78-A97*	Locking Tab (one-time-use part)	X	1
56	C071-2	Bracket (used with item 57)	X	1
57	10-6035-11**	Carburetor (Ref; Lycoming part no. 62C22451; installed on earlier R44s)		
58	AV10-6035-11*	Carburetor (Ref; Lycoming part no. 61C26050)		

NOTES * Avstar Fuel Systems, Inc. part no.
 ** Precision Airmotive part no.

Intentionally Blank

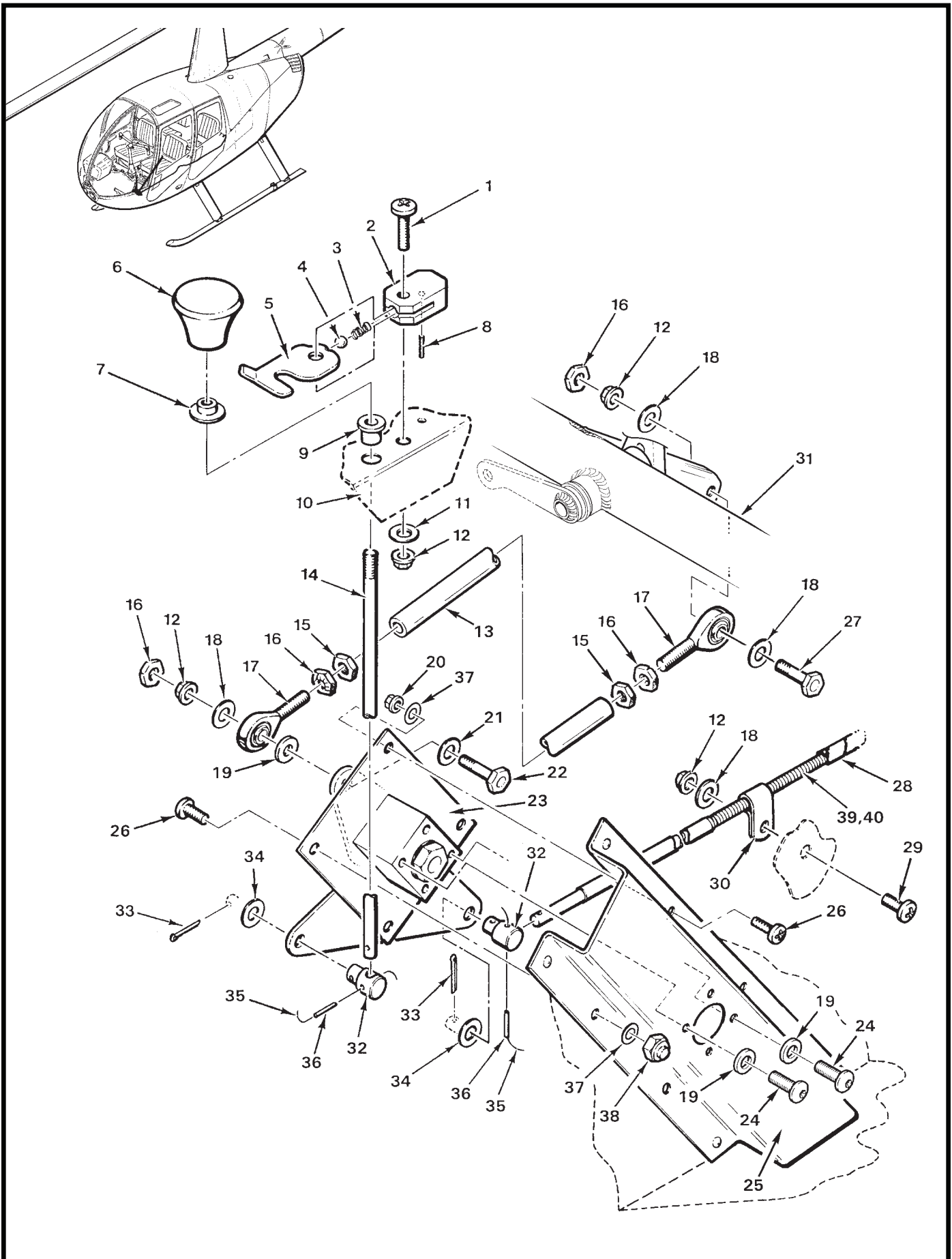

FIGURE AND INDEX NUMBER	PART NUMBER	DESCRIPTION	PARTS AVAIL	QTY PER ASSY
CARB HEAT ASSIST INSTALLATION*				
76-13-1	MS27039C1-11	Screw	X	1
2	D333-8	Block	X	1
3	D774-3	Spring	X	1
4	9529K13	Ball	X	1
5	D333-6	Catch	X	1
6	3704-SE	Knob	X	1
7	D333-5	Collar	X	1
8	MS16562-23	Spring Pin	X	1
9	2010	Bushing	X	1
10	C444-3	Cover Assembly - Cyclic (Ref)		
11	NAS620-10L	Washer	X	1
12	MS21042L3	Nut	X	4
13	A336-3	Push-Pull Tube	X	1
14	A587-3	Stem	X	1
15	AN315-3R	Nut	X	2
16	B330-7	Palnut	X	4
17	A933-3	Rod End	X	2
18	NAS1149F0332P	Washer	X	8
19	NAS1149F0363P	Washer	X	1
20	MS21042L08	Nut	X	4
21	AN960PD10L	Washer	X	5
22	NAS6603-8	Bolt	X	1
23	D334-3	Bellcrank Assembly (Incl items 12, 14, 16, 18, 19, 21, 22, 24, and 32 thru 36)	X	1
24	A142-4	Screw	X	2
25	D335-2	Stiffener (Ref)		
26	MS27039C0806	Screw	X	3
27	NAS6603-6	Bolt	X	1
28	B161-4	Spirap	X	A/R
29	MS27039C1-06	Screw	X	1
30	AN742-3	Clamp	X	1
31	C758	Collective Stick Assembly (Ref)		

NOTES * Ship S/N 0202 thru 9999.

Continues

FIGURE AND INDEX NUMBER	PART NUMBER	DESCRIPTION	PARTS AVAIL	QTY PER ASSY
CARB HEAT ASSIST INSTALLATION* (Cont'd)				
76-13-32	D333-3	Fitting	X	2
33	MS24665-210	Cotter Pin	X	2
34	NAS1149F0432P	Washer	X	2
35	MS20995C20	0.020 in. dia. Safety Wire	X	A/R
36	MS16562-4	Spring Pin	X	2
37	NAS1149FN816P	Washer	X	3
38	B340-4	Nut	X	3
39	C522-7	Control Assembly (Includes item 40. See Figure 76-9 for complete installation.)	X	1
40	A-912R	Inner Wire (not shown)	X	1

NOTES * Ship S/N 0202 thru 9999.

Intentionally Blank

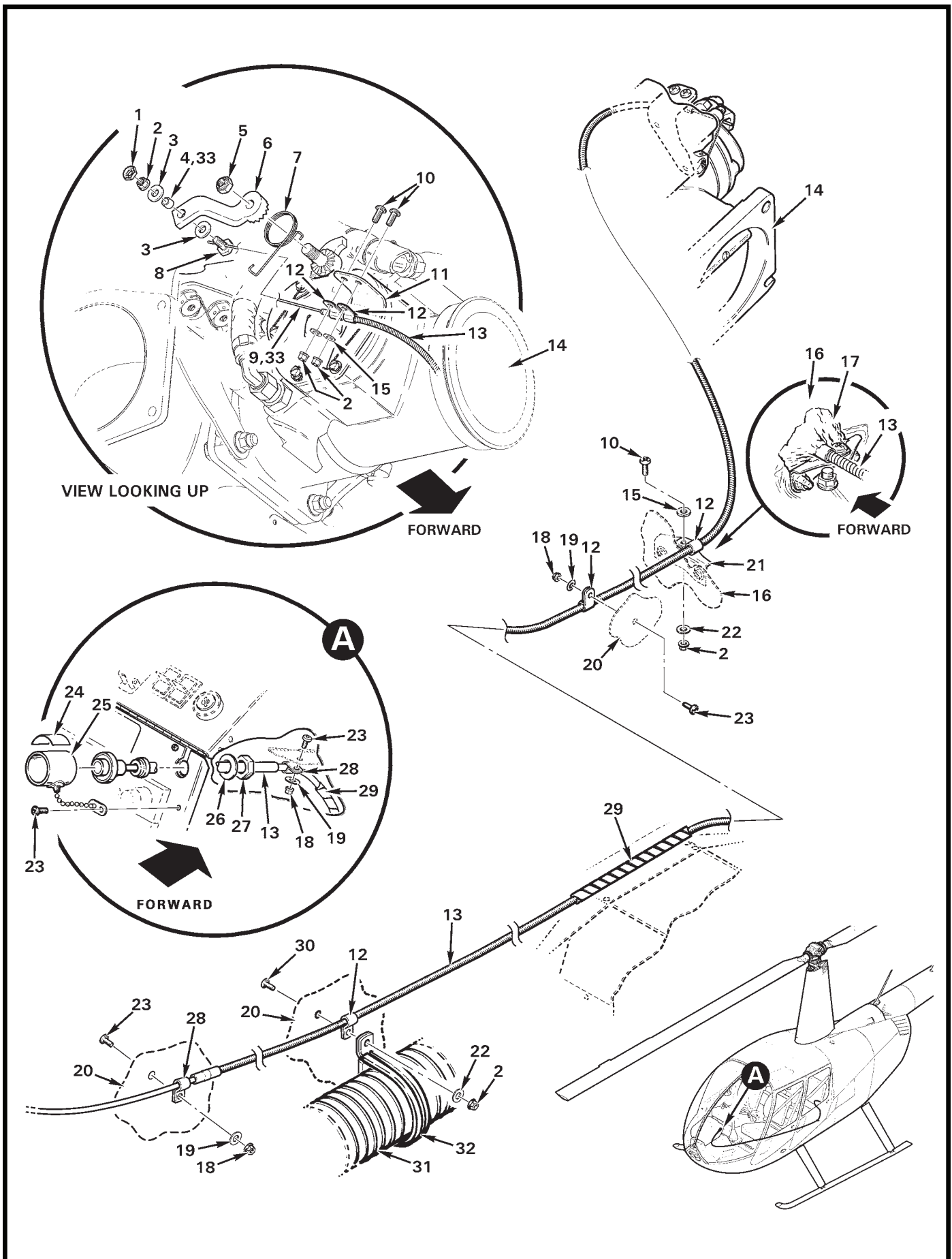

FIGURE AND INDEX NUMBER	PART NUMBER	DESCRIPTION	PARTS AVAIL	QTY PER ASSY
MIXTURE CONTROL INSTALLATION*				
76-17-1	B330-7	Palnut	X	1
2	D210-3	Nut	X	4
3	NAS1149E0363R	Washer	X	2
4	A130-48	Spacer (install using item 33)	X	1
5	—	Locknut**	O	1
6	—	Arm**	O	1
7	D930-1	Spring	X	1
8	A462-4	Fitting	X	1
9	A-641R1	Inner Wire	X	1
10	MS27039C1-07	Screw	X	3
11	D732-11**	Bracket (Ref)		
12	AN742-4	Clamp	X	5
13	A522-13	Control – Mixture (Supersedes A522-7; Incl items 9, 26, and 27)	X	1
14	2576630-4	Control – Fuel (Ref)		
15	NAS1149F0363P	Washer	X	3
16	—	Firewall – Vertical (Ref)		
17	B270-5	Sealant (at firewall)	X	A/R
18	MS21042L08	Nut	X	3
19	NAS1149FN816P	Washer	X	3
20	—	Keel Panel (Ref)		
21	D732-10	Angle	X	1
22	NAS1149F0332P	Washer	X	2
23	MS27039C0806	Screw	X	4
24	A654-45	Decal (guard instruction)	X	1
25	A950-3	Guard Assembly (Incl item 24)	X	1
26	—	Washer	O	1
27	—	Nut	O	1
28	AN742-3	Clamp	X	2
29	B161-4	Spirap	X	A/R
30	MS27039C1-08	Screw	X	1
31	A785-29	Hose – Heater (Ref, see Figure 21-37)		
32	MS21919WDG48	Clamp (Ref)		

NOTES * Ship S/N 10001 and subsequent.
 ** Supplied with fuel control.

Continues

FIGURE AND INDEX NUMBER	PART NUMBER	DESCRIPTION	PARTS AVAIL	QTY PER ASSY
76-17-33	A257-1	<p style="text-align: center;">MIXTURE CONTROL INSTALLATION*</p> <p>Grease</p>	X	A/R

NOTES * Ship S/N 10001 and subsequent.

CHAPTER 79
ENGINE OIL SYSTEM

<i>Figure</i>	<i>Title</i>	<i>Page</i>
79-1	Oil Cooler Installation	79.0
79-3	Oil System	79.2
79-7	Oil System	79.6
79-9	Oil Filter Installation	79.8
79-11	Oil Filter Installation	79.10

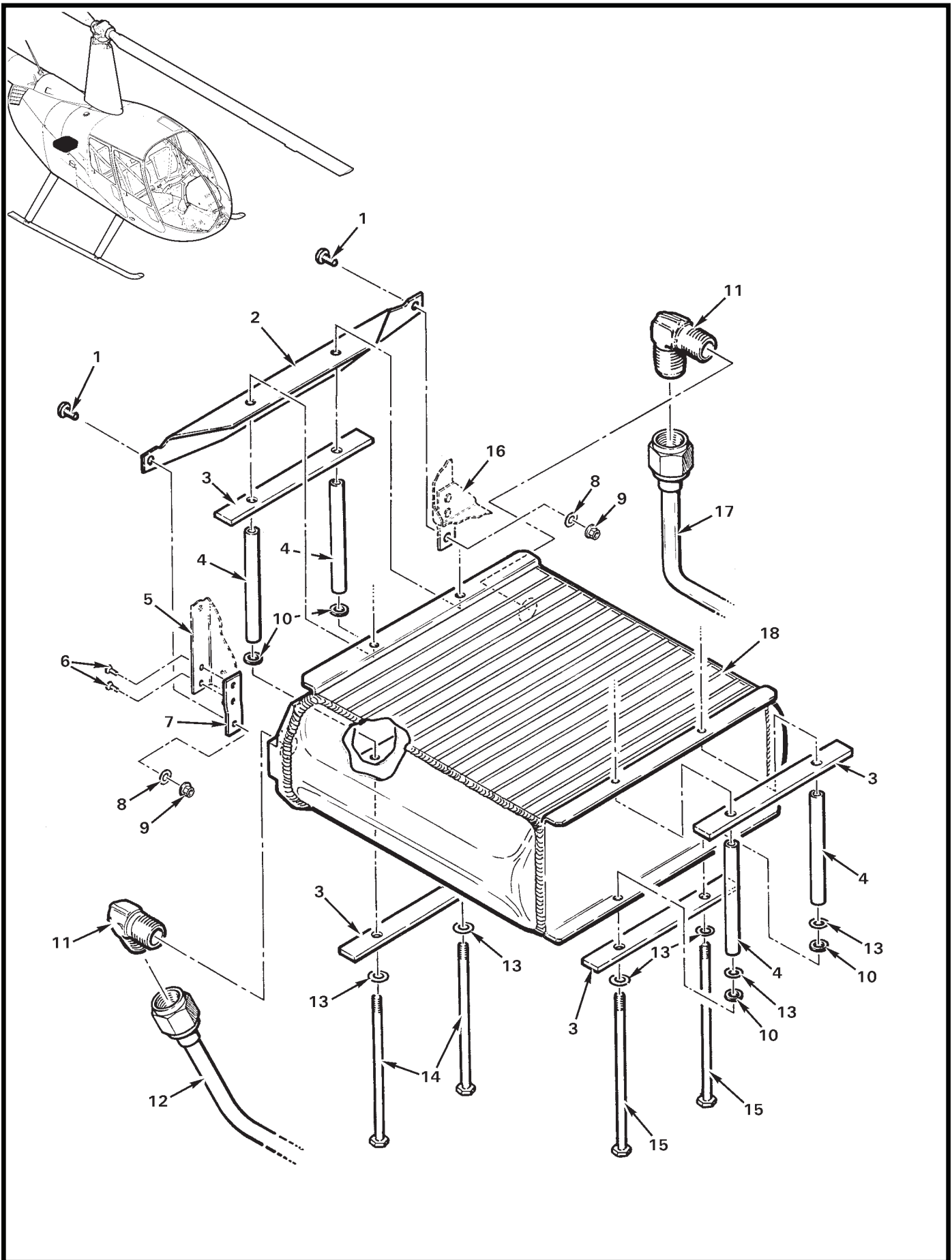

FIGURE AND INDEX NUMBER	PART NUMBER	DESCRIPTION	PARTS AVAIL	QTY PER ASSY
LARGE OIL COOLER INSTALLATION				
79-1-1	MS27039C0806	Screw	X	2
2	D636-1	Support	X	1
3	A668-1	Doubler	X	4
4	A130-49	Spacer	X	4
5	C305-8	Panel Assembly (Ref, see Figure 71-41)		
6	NAS1097AD4-4S	Rivet	X	2
7	D664-2	Strap	X	1
8	NAS1149FN816P	Washer	X	2
9	MS21042L08	Nut	X	2
10	NAS1149F0363P	Washer	X	4
11	MS20822-8	Elbow (install using item 19 on threads)	X	2
12	A723-15	Oil Line (outboard, helicopter-right; for ships with D723-1 oil filter adapter assembly, see Figure 79-9)	X	1
	A723-17	Oil Line (outboard, helicopter-right; for ships with 54J21208* oil filter adapter assembly; see Figure 79-11)	X	1
13	NAS1149F0332P	Washer	X	4
14	NAS6603-60	Bolt (or AN3-41A)	X	2
15	NAS6603-68	Bolt (or AN3-44A)	X	2
16	C309-5	Panel Assembly – RH Inboard (Ref, see Figure 71-41)		
17	A723-16	Oil Line (inboard, helicopter-right)	X	1
18	C649-2**	Oil Cooler – Large	X	1
19	B270-6	Sealant	X	A/R

20	KI-147	Large Oil Cooler Retrofit Kit (Replaces item 7 from Figure 79-3. Includes items 2, 6, 7, 12 [A723-15], 17 thru 19, and 21 thru 24.)	X	1
21	A701-1	Foil Tape (5-foot length)	X	1
22	C309-5	Panel Assembly – RH	X	1
23	C487-1	Retainer (straight)	X	1
24	C487-2	Retainer (bent)	X	1

NOTES * Lycoming part no.
 ** Width of oil cooler is 8.43-inches from bolt hole centerline to bolt hole center line.

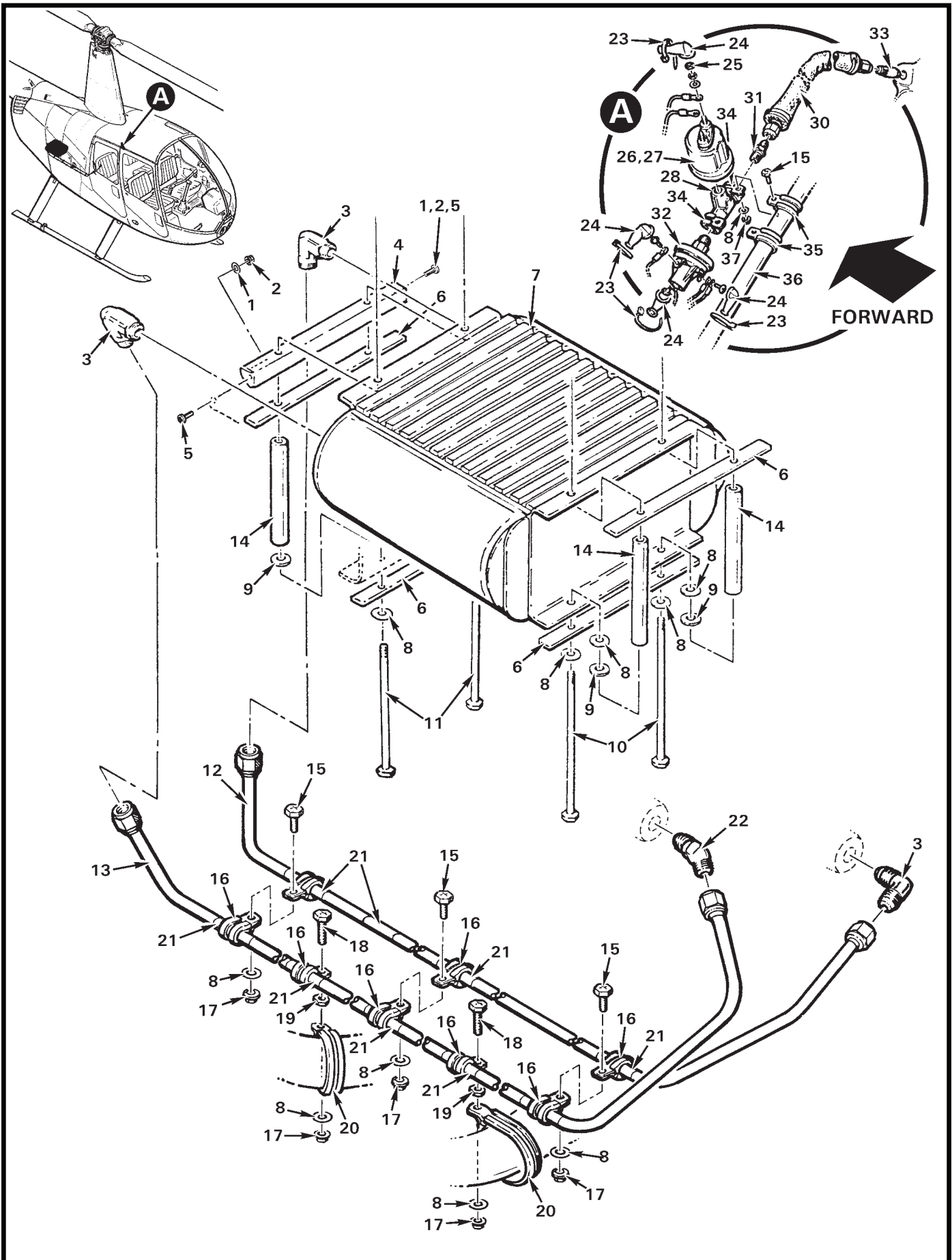

FIGURE AND INDEX NUMBER	PART NUMBER	DESCRIPTION	PARTS AVAIL	QTY PER ASSY
OIL SYSTEM*				
79-3-1	NAS1149FN816P	Washer	X	2
2	MS21042L08	Nut	X	2
3	MS20822-8	Elbow (use item 29 on threads)	X	3
4	C636-1	Support	X	1
5	MS27039C0806	Screw	X	2
6	A668-1	Doubler	X	4
7	C649-1*	Oil Cooler – Small (To replace, order KI-147 Large Oil Cooler Retrofit Kit. See Figure 79-1.)	X	1
8	NAS1149F0332P	Washer	X	6
9	NAS1149F0363P	Washer	X	4
10	NAS6603-60	Bolt	X	2
11	NAS6603-68	Bolt	X	2
12	A723-10	Oil Line	O	1
13	A723-9	Oil Line	O	1
14	A130-49	Spacer	X	4
15	AN3-3A	Bolt	X	7
16	MS21919WCH8	Clamp	X	8
17	MS21042L3	Nut	X	5
18	NAS428-3A6	Bolt	X	2
19	AN345-10	Nut	X	2
20	MS21919WDG28	Clamp (forward and aft intake tubes)	X	2
21	B158-212	Heat Shrink (9 places)	X	A/R
22	MS20823-8	Elbow (use item 29 on threads)	X	1
23	MS3367-4-9	Ty-Rap	X	5
24	MS25171-1S	Nipple	X	5
25	B330-6	Palnut	X	2
26	A058-3	Oil Pressure Sender and Line Assembly (Incl items 27 thru 32)	X	1
27	B308-1	Oil Pressure Sender	X	1
28	AN917-1D	Tee (use item 29 on threads)	X	1
29	B270-6	Sealant (4-oz tube)	X	A/R
30	B283-1	Hose Assembly	X	1
31	AN816-3D	Nipple	X	1
32	B426-1	Oil Pressure Switch (Hobbs part no. 76083-30)	X	1
33	A571-1	Fitting Assembly (install using item 29)	X	1
34	MS21919WDG9	Clamp	X	2

NOTES * Width of oil cooler is 7.94-inches from bolt hole centerline to bolt hole center line.

Continues

FIGURE AND INDEX NUMBER	PART NUMBER	DESCRIPTION	PARTS AVAIL	QTY PER ASSY
OIL SYSTEM (Cont'd)				
79-3-35	MS21919WDG14	Clamp	X	2
36	C046-1	Lower Frame Assembly, LH (Ref; replace with C046-21 and D046-2, see Figure 53-23)		
37	D210-3	Nut	X	2

NOTES

Intentionally Blank

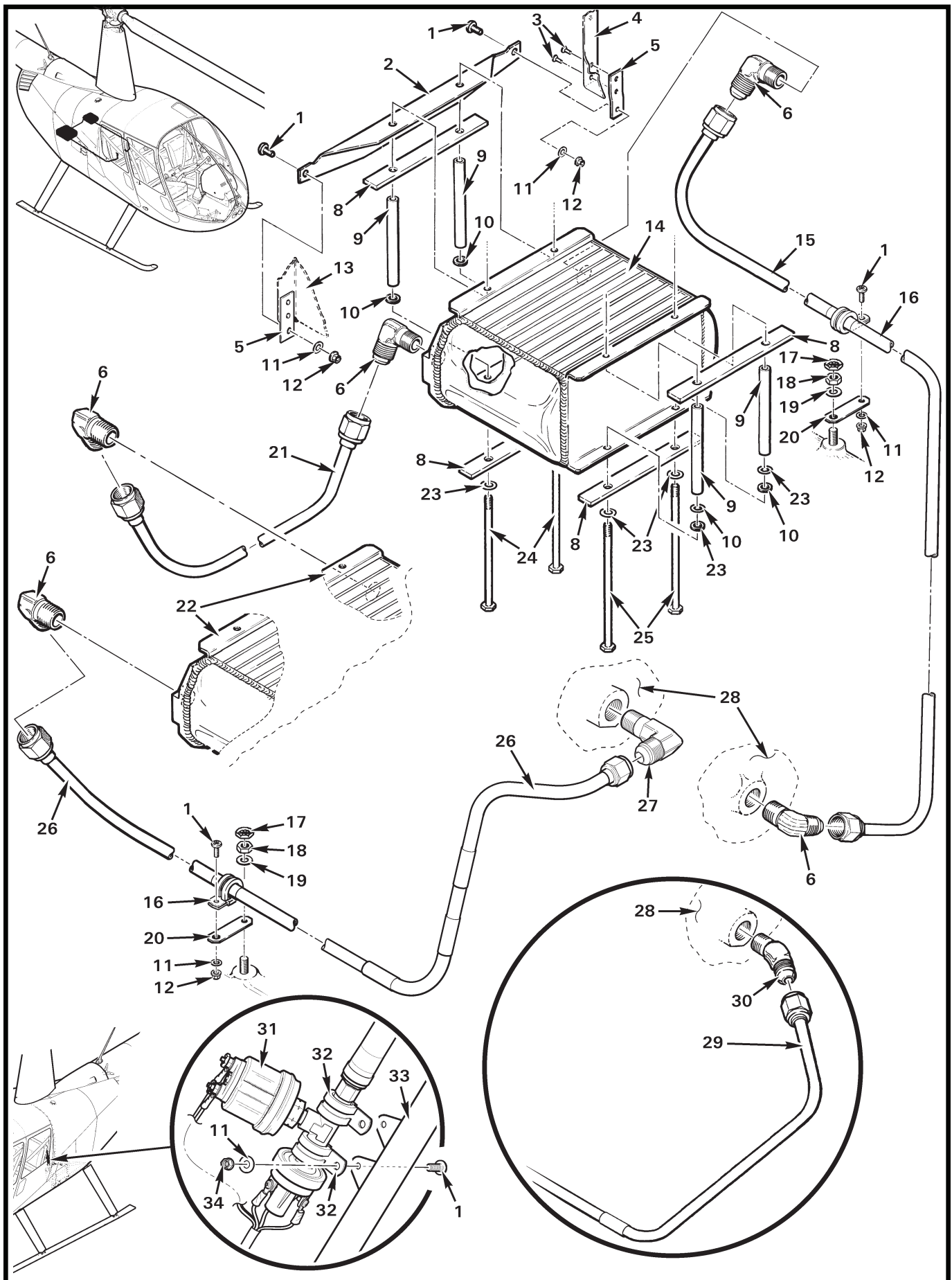

FIGURE AND INDEX NUMBER	PART NUMBER	DESCRIPTION	PARTS AVAIL	QTY PER ASSY
OIL SYSTEM*				
79-7-1	MS27039C0806	Screw	X	6
2	D636-2	Support	X	1
3	NAS1097AD4	Rivet	X	2
4	D380-1	Panel (Ref, see also Figure 71-37)		
5	D664-2	Strap	X	2
6	A880-668	Elbow (install using item 7)	X	5
7	B270-6	Sealant	X	A/R
8	A668-1	Doubler	X	4
9	A130-49	Spacer	X	4
10	NAS1149F0363P	Washer	X	4
11	NAS1149FN816P	Washer	X	6
12	MS21042L08	Nut	X	4
13	C310-4	Panel Assembly (Ref, see also Figure 71-37)		
14	C649-3	Oil Cooler (auxiliary)	X	1
15	D753-2	Line Assembly (helicopter-left)	X	1
16	NAS1715C8SW	Clamp	X	2
17	B330-12	Palnut	X	2
18	STD-1411	Nut	X	2
19	NAS1149F0432P	Washer	X	2
20	C357-3	Clip	X	2
21	D753-1	Line Assembly (cooler to cooler)	X	1
22	C649-2	Oil Cooler – Large (main; Ref, see also Figure 79-1)		
23	NAS1149F0332P	Washer	X	4
24	AN3-41A	Bolt (or NAS6603-60)	X	2
25	AN3-44A	Bolt (or NAS6603-68)	X	2
26	A723-18	Line Assembly (outboard, helicopter-right)	X	1
27	A457-21	Elbow (for use with item 26; install using item 7)	X	1
28	C145-2	Engine Assembly (Ref, IO-540-AE1A5)		
29	A723-15	Line Assembly (outboard, helicopter-right)	O	1
30	MS20823-8	Elbow (for use with item 29; install using item 7)	X	1
31	A058-3	Sender Assembly	X	1
32	MS21919WDG9	Clamp	X	2
33	C046	Lower Frame (Ref)		
34	MS21042L08	Nut	X	2

NOTES * Ship S/N 10001 thru 29999.

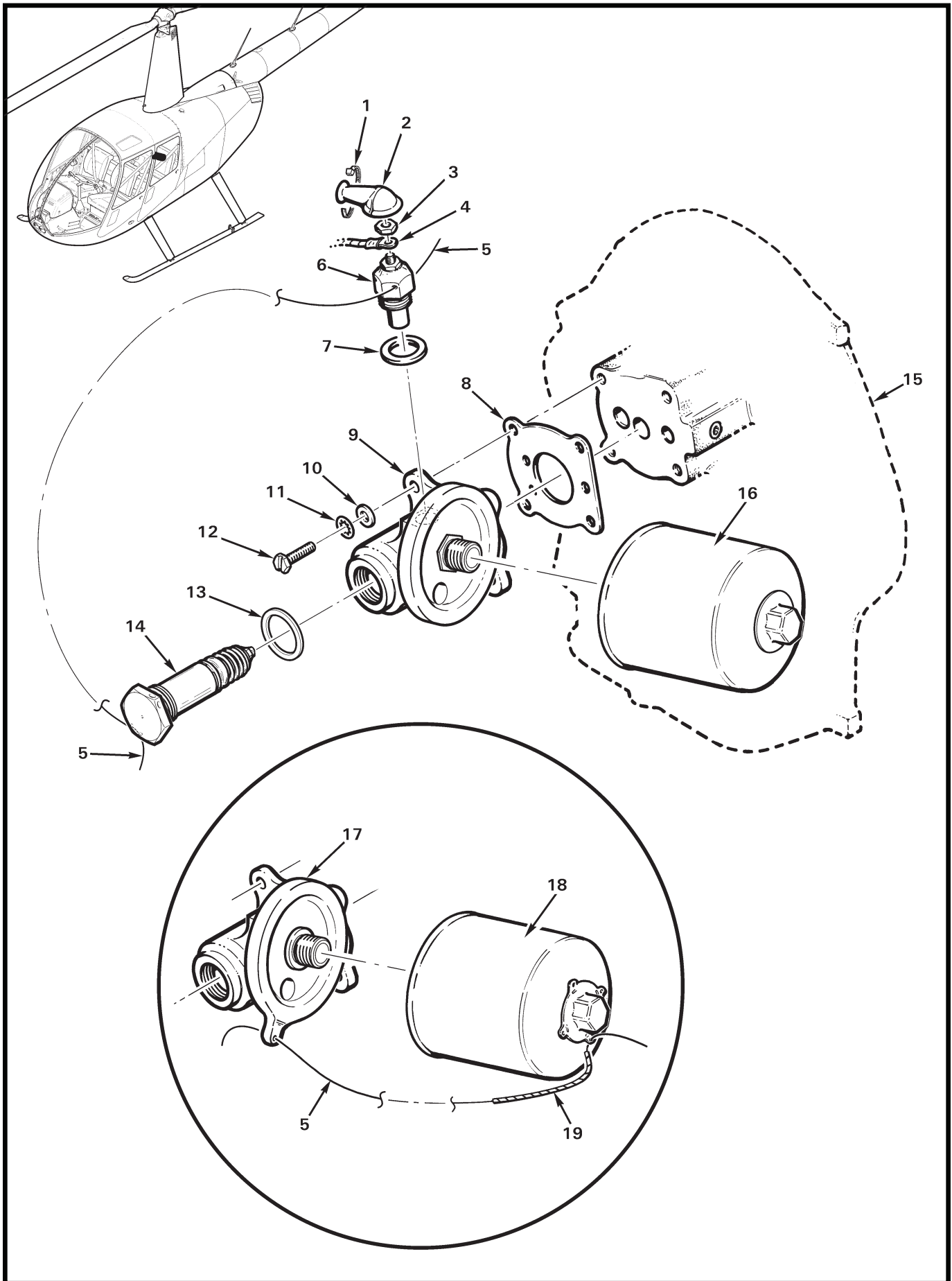

FIGURE AND INDEX NUMBER	PART NUMBER	DESCRIPTION	PARTS AVAIL	QTY PER ASSY
OIL FILTER INSTALLATION				
79-9-1	MS3367-4-9	Ty-rap	X	1
2	MS25171-1S	Nipple	X	1
3	—	Nut (Ref)		
4	C049-8	Harness Assembly	X	1
5	MS20995C32	0.032-in. dia. Safety Wire	X	A/R
6	A760	Oil Temperature Sender (Ref; see also Figure 96-49)		
7	15-724	Gasket (Ref; see also Figure 96-49)		
8	61173*	Gasket – Oil Filter Adapter	X	1
9	D723-1	Adapter – Oil Filter (revision “H” and subsequent)	X	1
10	STD-8*	Washer	X	4
11	STD-160*	Lockwasher	X	4
12	STD-1856*	Screw	X	4
13	76510*	Gasket	X	1
14	53E22144*	Thermostatic Oil Cooler Bypass Valve	X	1
15	—	Accessory Housing (Ref)		
16	B123-2	Oil Filter	X	1
17	D723-1	Adapter – Oil Filter (Revision “G” and prior, provisions for safety wire. Ref; no longer available.)		
18	B123-1	Oil Filter (provision for safety wire)	O	1
19	B161-102	Spirap	X	A/R
* * *				
20	KI-163**	Full-Flow Oil Filter Installation Kit (Incl items 8, 9, 11, 13, and 16)	X	1

NOTES * Lycoming part no.
 ** For R44s without previously installed oil filter.

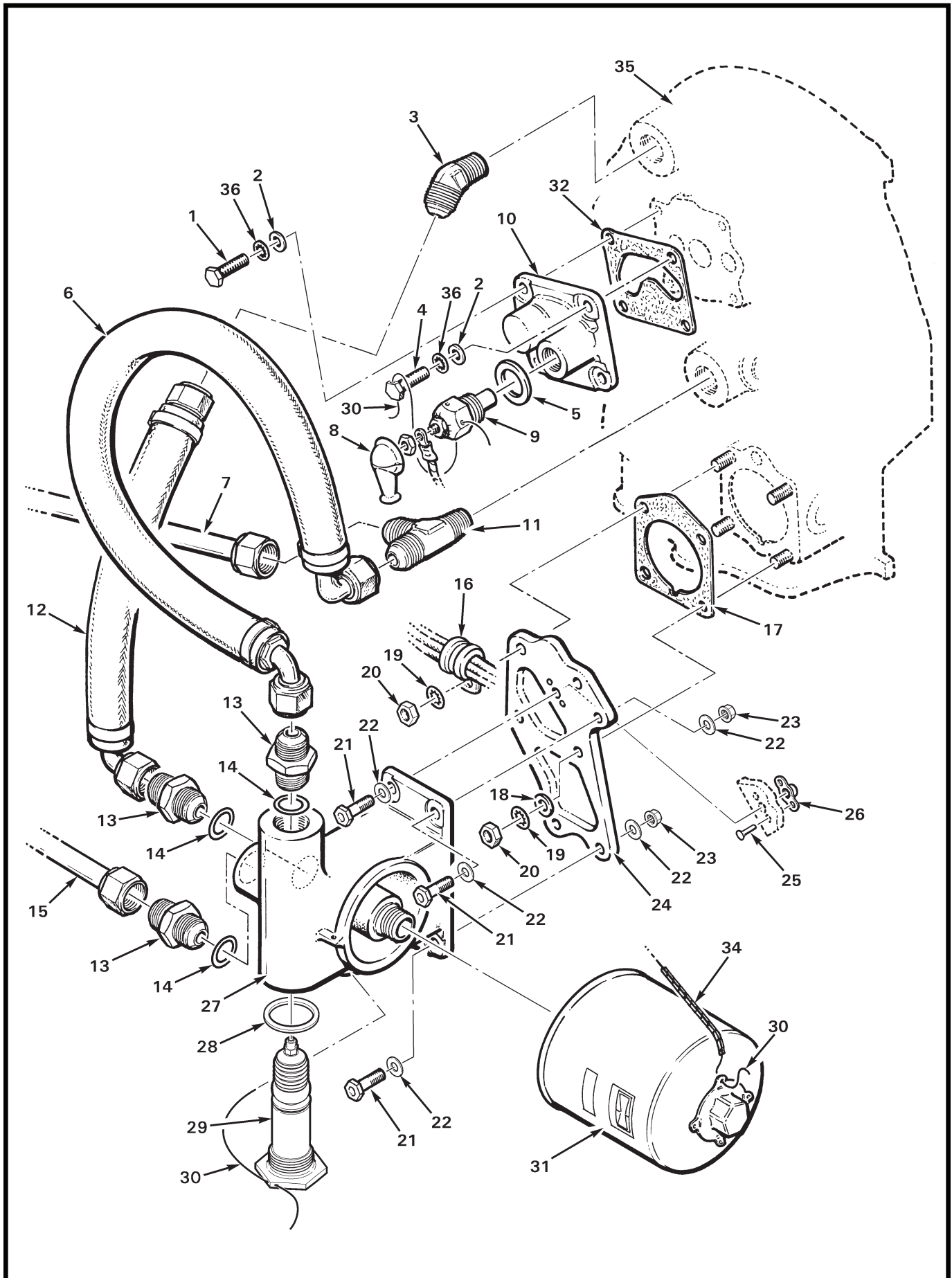

FIGURE AND INDEX NUMBER	PART NUMBER	DESCRIPTION	PARTS AVAIL	QTY PER ASSY
OIL FILTER INSTALLATION*				
79-11-1	LW-25-0.94**	Bolt (0.25"-20 x 0.94 in. length)	X	3
2	STD-8**	Washer	X	4
3	MS20823-8	Elbow - 45° (install using item 33)	X	1
4	LW-25H-1.00**	Bolt (0.25"-20 x 1.00 in. length, drilled head)	X	1
5	15-724	Gasket	X	1
6	B283-5	Hose Assembly***	O	1
7	A723-10	Oil Line Assembly*** (return from cooler; use with C649-1 small oil cooler. See also Figure 79-1.)	O	1
	A723-16	Oil Line Assembly (return from cooler; use with C649-2 large oil cooler. See also Figure 79-1.)	X	1
8	MS25171-1S	Nipple	X	1
9	A760-1	Oil Temperature Sender (includes nuts and item 5)	X	1
10	21M21643**	Port Cover - Oil Screen	O	1
11	A880-1168	Tee (install using item 33)	X	1
12	B283-4	Hose Assembly***	O	1
13	A880-968	Union	X	3
14	MS28778-8	Packing	X	3
15	A723-13	Oil Line Assembly*** (out to cooler; use with C649-1 small oil cooler and item 27. See also Figure 79-1.)	O	1
	A723-17	Oil Line Assembly*** (out to cooler; use with C649-2 large oil cooler and item 27. See also Figure 79-1.)	O	1
16	MS21333-113	Clamp	X	1
17	69551**	Gasket	X	1
18	STD-35**	Washer (Ref, supplied with engine)	X	3
19	STD-475**	Washer (Ref, internal teeth, one-time use)	X	4
20	STD-1410**	Nut (Ref, supplied with engine)	X	4
21	NAS6604-8	Bolt	X	4
22	NAS1149F0432P	Washer	X	7
23	D210-4	Nut	X	3
24	B354-1	Plate Assembly (Incl items 25 and 26)	X	1
25	MS20426AD4	Rivet	X	2
26	MS21075L4E	Nutplate	X	1
27	54J21208**	Oil Filter Adapter Assembly***	O	1

NOTES * Ship S/N 1150 and prior.
 ** Lycoming part no.
 *** Order KI-163 Full-Flow Oil Filter Installation Kit; see Figure 79-9.

Continues

FIGURE AND INDEX NUMBER	PART NUMBER	DESCRIPTION	PARTS AVAIL	QTY PER ASSY
OIL FILTER INSTALLATION* (Cont'd)				
79-11-28	06E19769-0.63**	Gasket	X	1
29	53E22144**	Bypass Valve Assembly - Thermostatic Oil Cooler	X	1
30	MS20995C32	0.032-in. dia. Safety Wire	X	A/R
31	CH48103-1	Oil Filter (Champion part no.; alternate part no. CH48103)	X	1
32	06B21644**	Gasket	X	1
33	B270-6	Sealant (4-oz. tube)	X	A/R
34	B161-102	Spirap (0.125 in. dia.)	X	A/R
35	21C21539-02**	Housing - Accessory (Ref)		
36	STD-160**	Lockwasher	X	4

NOTES * Ship S/N 1150 and prior.
 ** Lycoming part no.

CHAPTER 90
POLICE VERSION

<i>Figure</i>	<i>Title</i>	<i>Page</i>
90-1	Camera and Gimbal Installation	90.0
90-3	Camera and Gimbal Fairing and Cover	90.2
90-5	Searchlight and Gimbal Installation	90.4
90-9	Searchlight and Gimbal Support Installation	90.8
90-11	PA/Siren Speaker Assembly	90.10
90-13	PA/Siren System Installation	90.12
90-15	PA/Siren System Installation	90.14
90-17	VCR Installation	90.16
90-19	VCR Wiring Installation	90.18
90-21	HD Microwave System - Nucomm	90.20
90-23	HD Microwave System - Vislink	90.22
90-27	HD Microwave System - POD Antenna	90.26
90-29	Alternator Installation	90.28

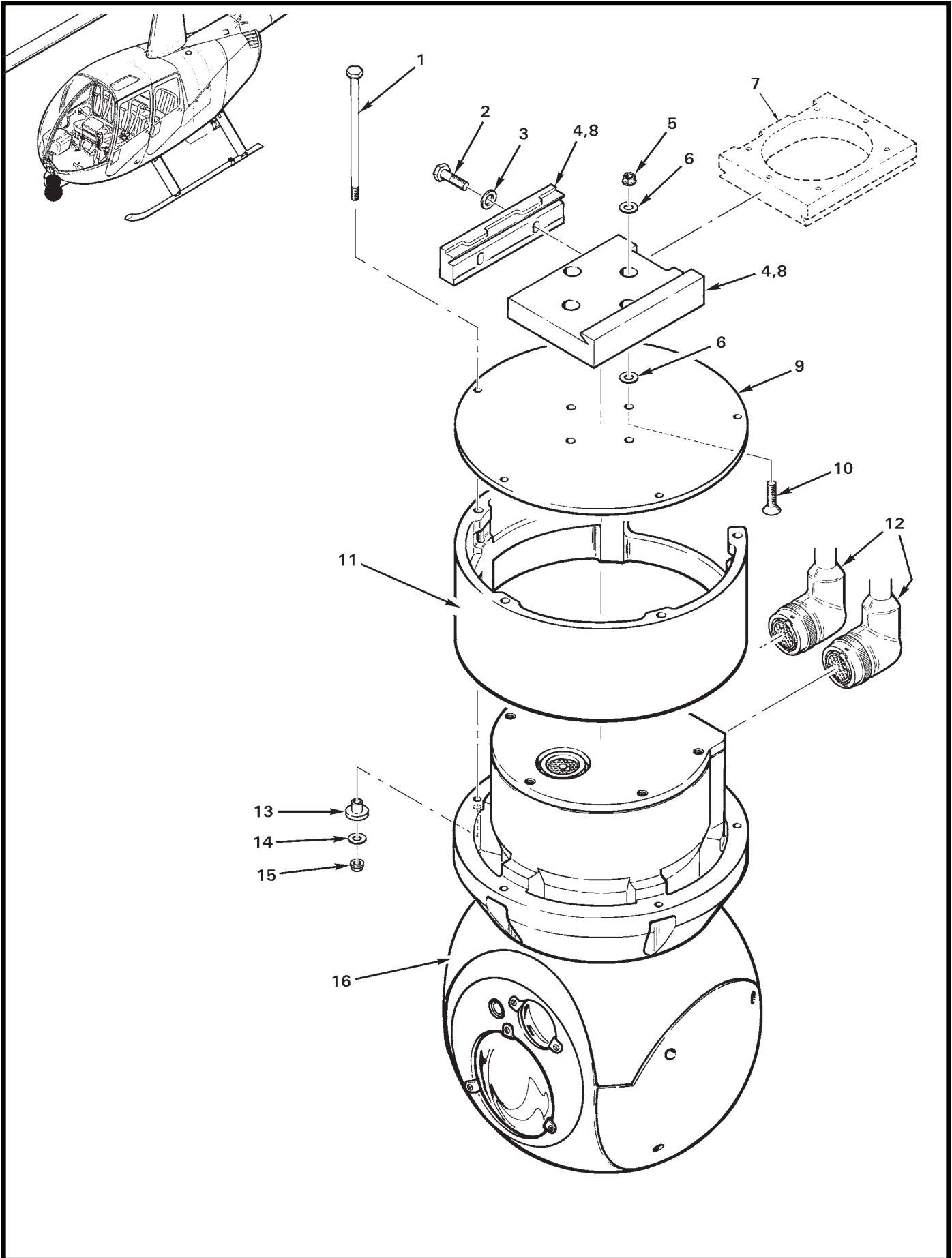

FIGURE AND INDEX NUMBER	PART NUMBER	DESCRIPTION	PARTS AVAIL	QTY PER ASSY
CAMERA AND GIMBAL INSTALLATION				
90-1-1	AN3-040A	Bolt	O	5
2	—	Bolt	O	2
3	—	Washer	O	2
4	IR-4100-1*	Adapter Assembly	O	1
5	MS21042L4	Nut	X	4
6	NAS1149D0463J	Washer	O	8
7	D400-1	Block (Ref, see Figure 90-9)		
8	IR-410*	Adapter Assembly - Gimbal Installation (Incl items 1 thru 6, 9 thru 11, and 13 thru 15)	X	1
9	IR-610-1*	Mount Plate	O	1
10	MS24693S297	Screw	O	4
11	IR-630-1*	Spacer	O	1
12	10349-104-1-C1**	Cable Pair (Ref)		
13	IR-620-1*	Bushing	O	5
14	NAS1149D0363J	Washer	O	5
15	MS21042L3	Nut	X	5
16	10369-202**	Gimbal Assembly (NTSC, Model No. FSI MK II; Ref)		

NOTES * Paravion Tech, Inc. part no.
 ** Inframetrics part no.

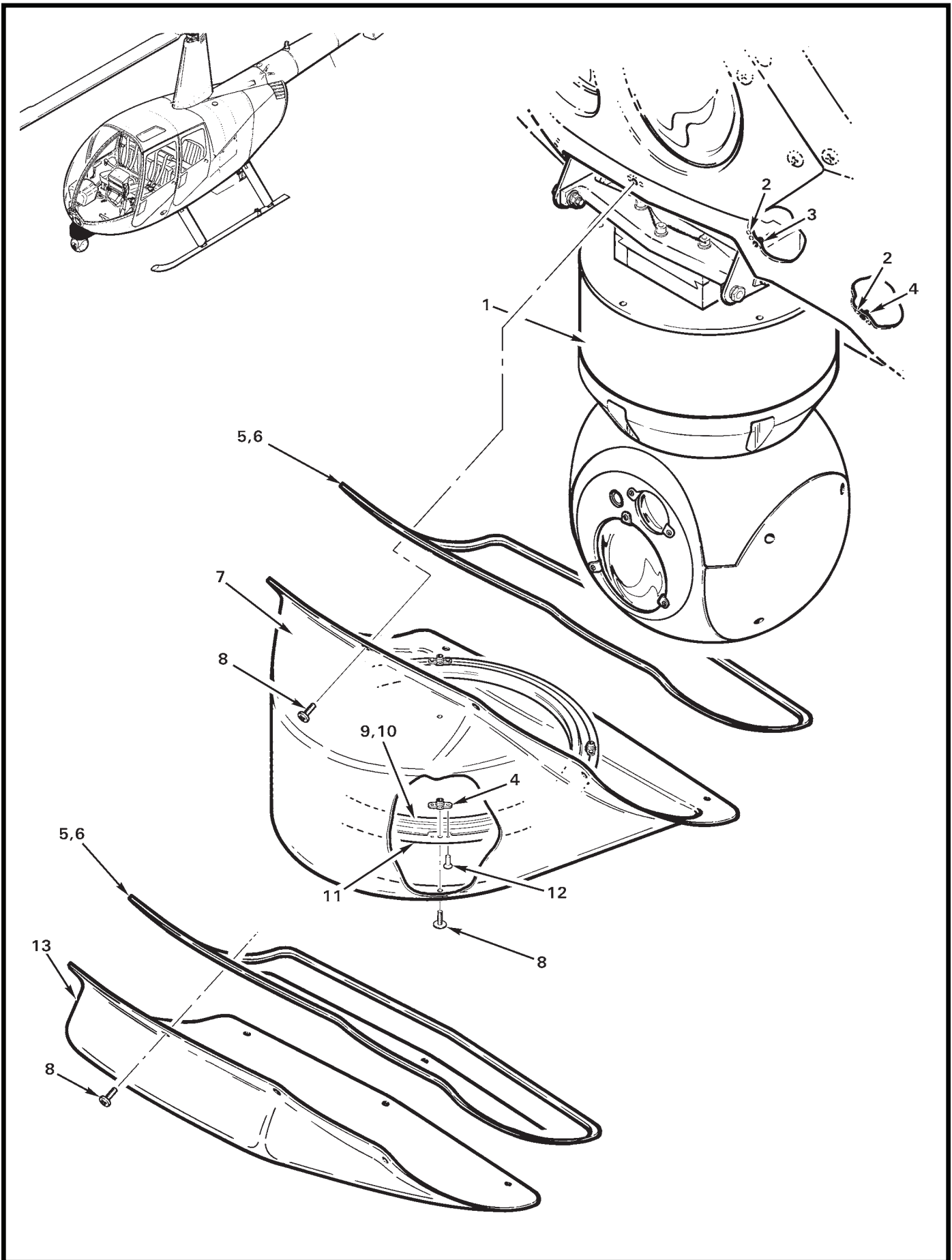

FIGURE AND INDEX NUMBER	PART NUMBER	DESCRIPTION	PARTS AVAIL	QTY PER ASSY
CAMERA AND GIMBAL FAIRING AND COVER				
90-3-1	10369-202*	Gimbal Assembly (Ref; Model No. FSI MK II, see Figure 90-1)		
2	NAS1097AD3	Rivet	X	24
3	MS21071L08	Nutplate	X	2
4	MS21069L08	Nutplate ([10] on helicopter chin, [4] on item 11)	X	A/R
5	A226-3	Seal (install using item 6)	X	A/R
6	B270-4	Sealant (silicone)	X	A/R
7	D412-1	Fairing	X	1
8	AN526C832R7	Screw	X	12
9	507P-SP	Seal (install using item 10)	X	A/R
10	B270-10	Adhesive	X	A/R
11	D350-6	Ring Assembly (Incl items 4 [4] and 12)	X	1
12	MS20470AD3	Rivet	X	8
13	D412-2	Cover (for use when item 1 is removed)	X	1

NOTES * Inframetrics part no.

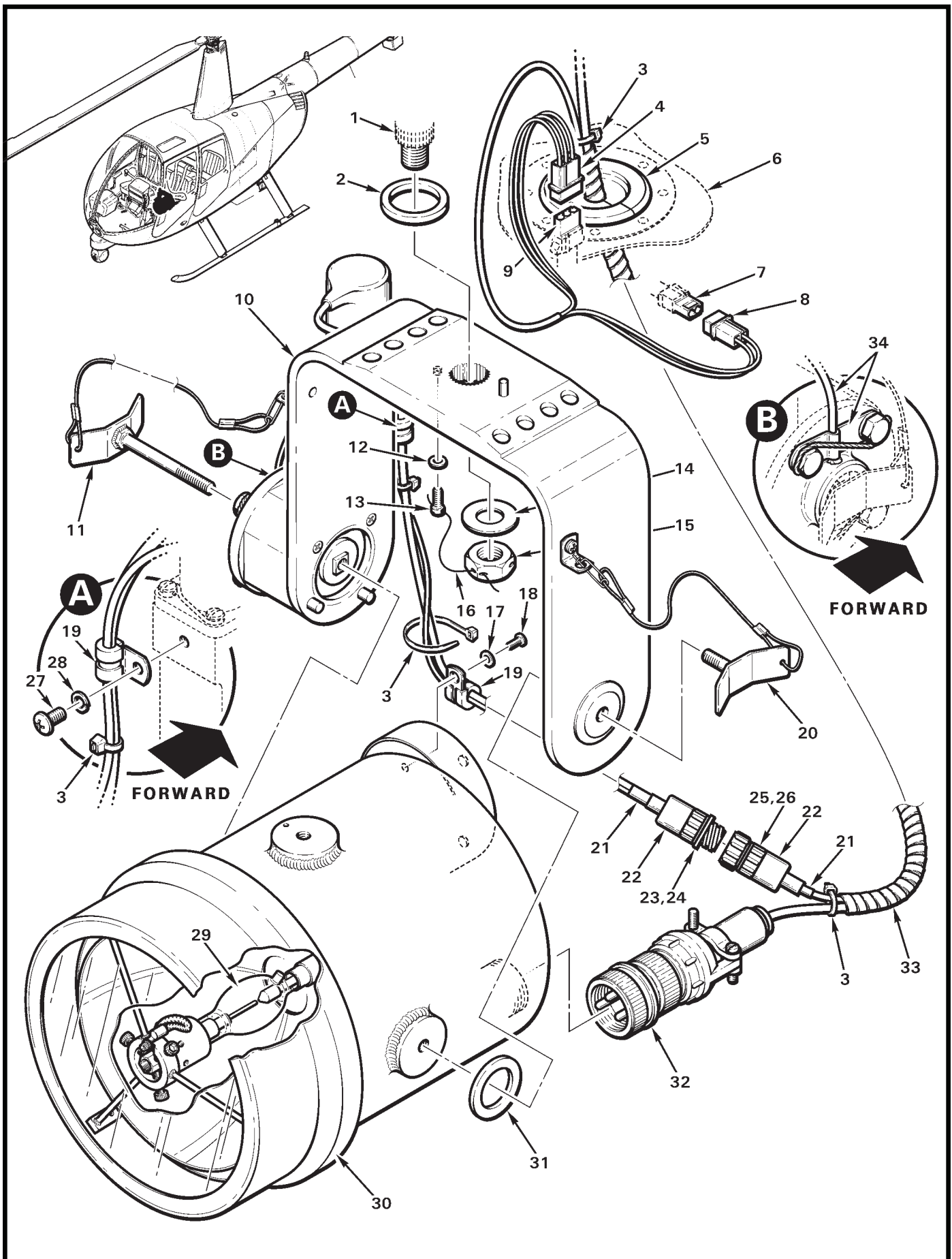

FIGURE AND INDEX NUMBER	PART NUMBER	DESCRIPTION	PARTS AVAIL	QTY PER ASSY
SEARCHLIGHT AND GIMBAL INSTALLATION				
90-5-1	D432-4	Gearmotor Assembly - Elevation (Ref; includes items 14 and 15)		
2	D405-4	Washer (optional)	X	1
3	MS3367-4-9	Ty-Rap	X	4
4	B263-34	Housing	X	1
	B263-1	Pin	X	3
5	D402-1	Grommet	X	1
6	C015-4	Skin (RH, Ref)		
7	B263-33	Housing (Ref)	X	1
	B263-2	Socket (Ref)	X	2
8	B263-32	Housing	X	1
	B263-1	Pin	X	2
9	B263-35	Housing	X	1
	B263-2	Socket	X	3
10	D432-3	Gimbal Assembly - Manual (Includes items 11 thru 13, 20, and elevation gearmotor assembly.)	X	1
	D432-1	Gimbal Assembly - Slaved (Includes items 11 thru 13, 20, 34, and elevation gearmotor assembly.)	X	1
11	017821-105*	Wing Bolt Assembly (Includes cable, clip, bracket, screw, and washer as shown.)	O	1
12	—	Washer	O	1
13	MS51960-65	Screw	O	1
14	MS15795-820	Washer	O	1
15	NAS509-10	Nut	O	1
16	MS20995C32	0.032 in. dia. Safety Wire	X	A/R
17	—	Washer	O	1
18	MS35206-328	Screw	X	1
19	MS21919WDG3	Clamp (slaved Gimbal)	X	2
	MS21919WDG2	Clamp (manual Gimbal)	X	2
20	017821-101*	Wing Bolt Assembly (Includes cable, clip, bracket, screw, and washer as shown.)	O	1
21	B158-3	Heat Shrink	X	A/R
22	54010-1	Seal (cable entry)	X	A/R

NOTES * Spectrolab, Inc., part no.

Continues

FIGURE AND INDEX NUMBER	PART NUMBER	DESCRIPTION	PARTS AVAIL	QTY PER ASSY
SEARCHLIGHT AND GIMBAL INSTALLATION (Cont'd)				
90-5-23	205841-2	Receptacle	X	1
	66506-9	Pin ([5] required for slaved Gimbal, [2] required for manual Gimbal)	X	A/R
	206403-1	Seal - Peripheral (inside receptacle, not shown; install using item 24)	X	1
24	B270-17	Adhesive	X	A/R
25	D403-2	Harness Assembly (Includes items 4, 8, 21, 22, 26, and wires as an assembled unit.)	X	1
26	205838-1	Plug	X	1
	66504-9	Socket	X	5
27	MS27039C1-06	Screw	X	1
28	B332-43	Lockwasher	X	1
29	030060-1 *	Lamp - Xenon (500-watt)	X	1
30	024711-31 *	Searchlight Assembly (Incl items 17 and 29)	X	1
31	D405-6	Washer (attached to item 30 with adhesive back)	X	1
32	D599-3/-9	Harness	X	1
33	B161-8	Spirap	X	A/R
34	6105	Slass Sensor - Gimbal (Ref; installed in slaved Gimbal only)	O	1

NOTES * Spectrolab, Inc., part no.

Intentionally Blank

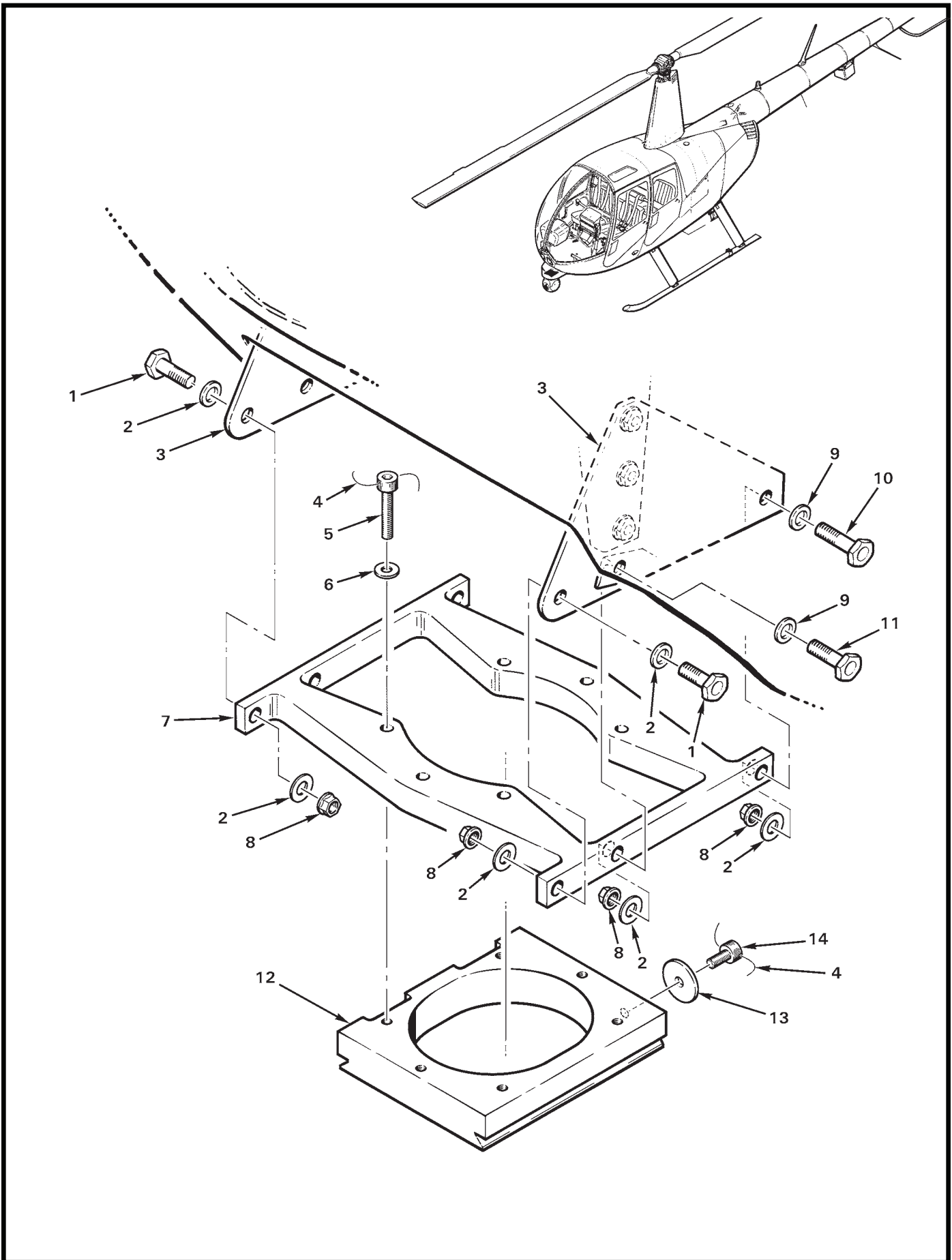

FIGURE AND INDEX NUMBER	PART NUMBER	DESCRIPTION	PARTS AVAIL	QTY PER ASSY
SEARCHLIGHT AND GIMBAL SUPPORT INSTALLATION				
90-9-1	NAS6604-4	Bolt	X	2
2	NAS1149F0432P	Washer	X	8
3	D349-1	Support (Ref)		
4	MS20995C32	0.032 in. dia. Safety Wire	X	A/R
5	NAS1352-3H16P	Screw	X	6
6	NAS1149F0332P	Washer	X	6
7	D349-3	Plate	X	1
8	MS21042L4	Nut	X	6
9	A141-11	Washer	X	4
10	NAS6604-7	Bolt	X	2
11	NAS6604-5	Bolt	X	2
12	D400-1	Block	X	1
13	A141-18	Washer	X	1
14	NAS1352-3H6P	Screw	X	1

NOTES

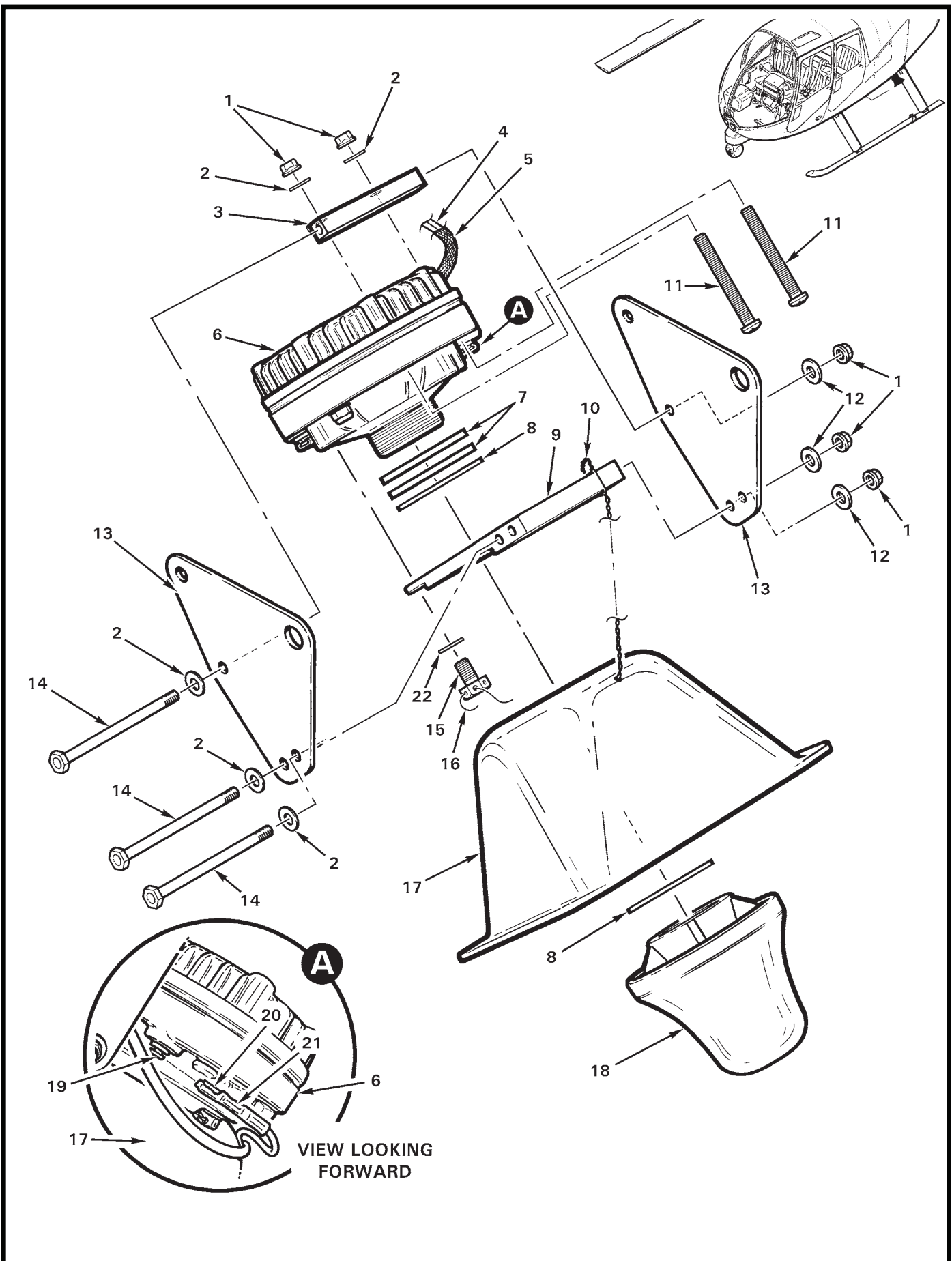

FIGURE AND INDEX NUMBER	PART NUMBER	DESCRIPTION	PARTS AVAIL	QTY PER ASSY
PA/SIREN SPEAKER ASSEMBLY				
90-11-1	MS21042L3	Nut	X	5
2	NAS1149F0332P	Washer	X	5
3	C644-1	Support	X	1
4	- 400	Wire (Ref, terminal no. 1)		
	- 401	Wire (Ref, terminal no. 2)		
5	B266-4	Sleeving	X	A/R
6	SA340TS*	Speaker - Siren (Incl items 4, 7, 8, 17, and 18)	X	1
7	—	Washer (thick)	O	2
8	—	Washer (thin)	O	1
9	A644-3	Support	X	1
10	MS20995C20	0.020 in. dia. Safety Wire	X	A/R
11	NAS603-32P	Screw	X	2
12	NAS1149F0363P	Washer	X	2
13	C663-1	Plate	X	2
14	NAS6603-44	Bolt	X	3
15	MS20074-04-03	Bolt	X	3
16	MS20995C41	0.041 in. dia. Safety Wire	X	A/R
17	—	Horn (Ref)		
18	—	Retainer - Horn (Ref)		
19	—	Terminal (no. 2, for -401 wire. Terminal no. 1 for -400 wire [not shown].)		
20	B262-4	Receptacle	X	2
21	MS25171-1S	Nipple	X	2
22	NAS1149F0432P	Washer	X	3

NOTES * Whelen Engineering part no.

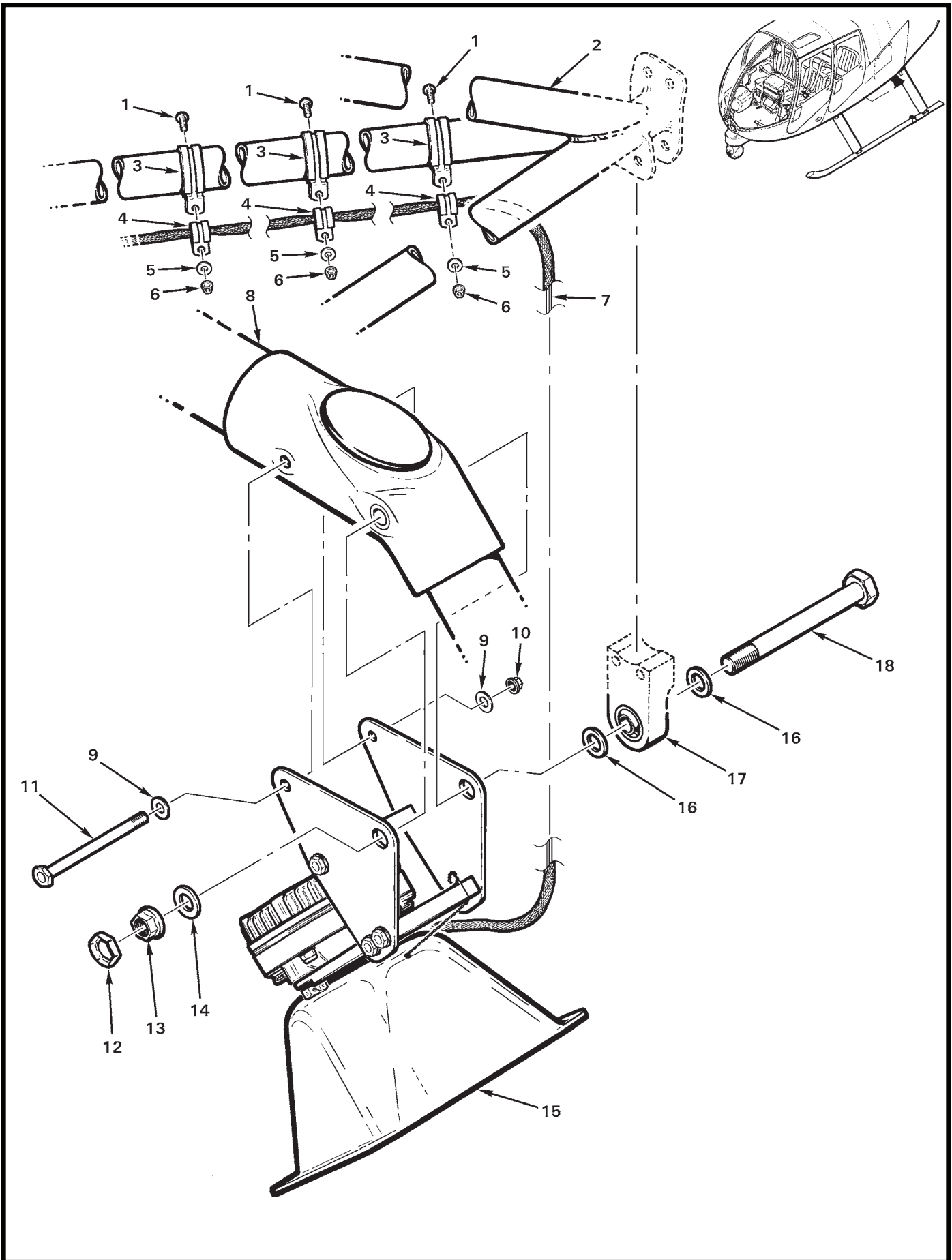

FIGURE AND INDEX NUMBER	PART NUMBER	DESCRIPTION	PARTS AVAIL	QTY PER ASSY
PA/SIREN SYSTEM INSTALLATION				
90-13-1	MS27039C0807	Screw	X	3
2	C046	Lower Frame - (LH, Ref)		
3	MS21919WDG16	Clamp	X	3
4	MS21919WDG2	Clamp	X	3
5	NAS1149FN816P	Washer	X	3
6	MS27042L08	Nut	X	3
7	- 400	Wire (Ref, see Figure 90-11)		
	- 401	Wire (Ref, see Figure 90-11)		
8	C014	Landing Gear Assembly (Ref)		
9	NAS1149F0432P	Washer	X	2
10	MS21042L4	Nut	X	1
11	NAS6604-43	Bolt	X	1
12	B330-21	Palnut	X	12
13	NAS1291-7	Nut	X	1
14	NAS1149F0763P	Washer	X	1
15	SA340TS	Siren Speaker (Ref, see Figure 90-11)		
16	C141-4	Washer	X	2
17	C574-1	Bearing (Ref)		
18	NAS6607-54	Bolt	X	1

NOTES

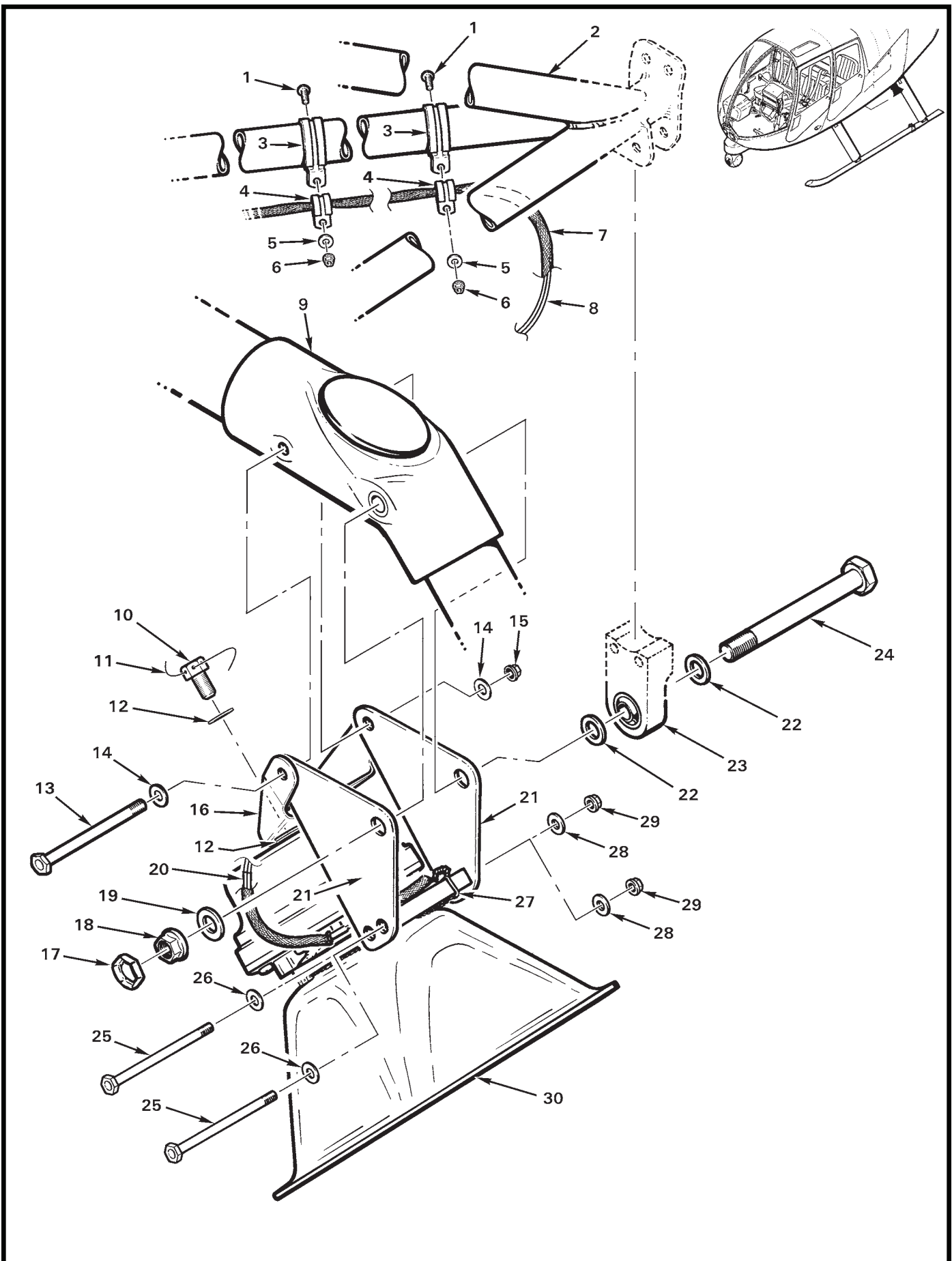

FIGURE AND INDEX NUMBER	PART NUMBER	DESCRIPTION	PARTS AVAIL	QTY PER ASSY
PA/SIREN SYSTEM INSTALLATION*				
90-15-1	MS27039C0807	Screw	X	2
2	C046	Lower Frame - (LH, Ref)		
3	MS21919WDG16	Clamp	X	2
4	MS21919WDG2	Clamp	X	2
5	NAS1149FN816P	Washer	X	2
6	MS21042L08	Nut	X	2
7	B266-4	Sleeving	X	A/R
8	- 400	Wire (red, Ref)		
	- 401	Wire (black, Ref)		
9	C014	Landing Gear Assembly (Ref)		
10	MS20074-05-05	Bolt	X	1
11	MS20995C32	0.032 in. dia. Safety Wire	X	A/R
12	NAS1149F0563P	Washer	X	3
13	NAS6604-45	Bolt	X	1
14	NAS1149F0432P	Washer	X	2
15	MS21042L4	Nut	X	1
16	C663-2	Bracket	X	1
17	B330-21	Palnut	X	1
18	NAS1291-7	Nut	X	1
19	NAS1149F0763P	Washer	X	1
20	B261-2	Splice - Wire	X	2
21	C663-1	Plate	X	2
22	C141-4	Washer	X	2
23	C574-1	Bearing (Ref)		
24	NAS6607-54	Bolt	X	1
25	NAS6603-44	Bolt	X	2
26	NAS1149F0332P	Washer	X	2
27	MS20995C20	0.020 in. dia. Safety Wire	X	A/R
28	NAS1149F0363P	Washer	X	2
29	MS21042L3	Nut	X	2
30	SA340TS	Siren Speaker	X	1

NOTES * Earlier Police ships.

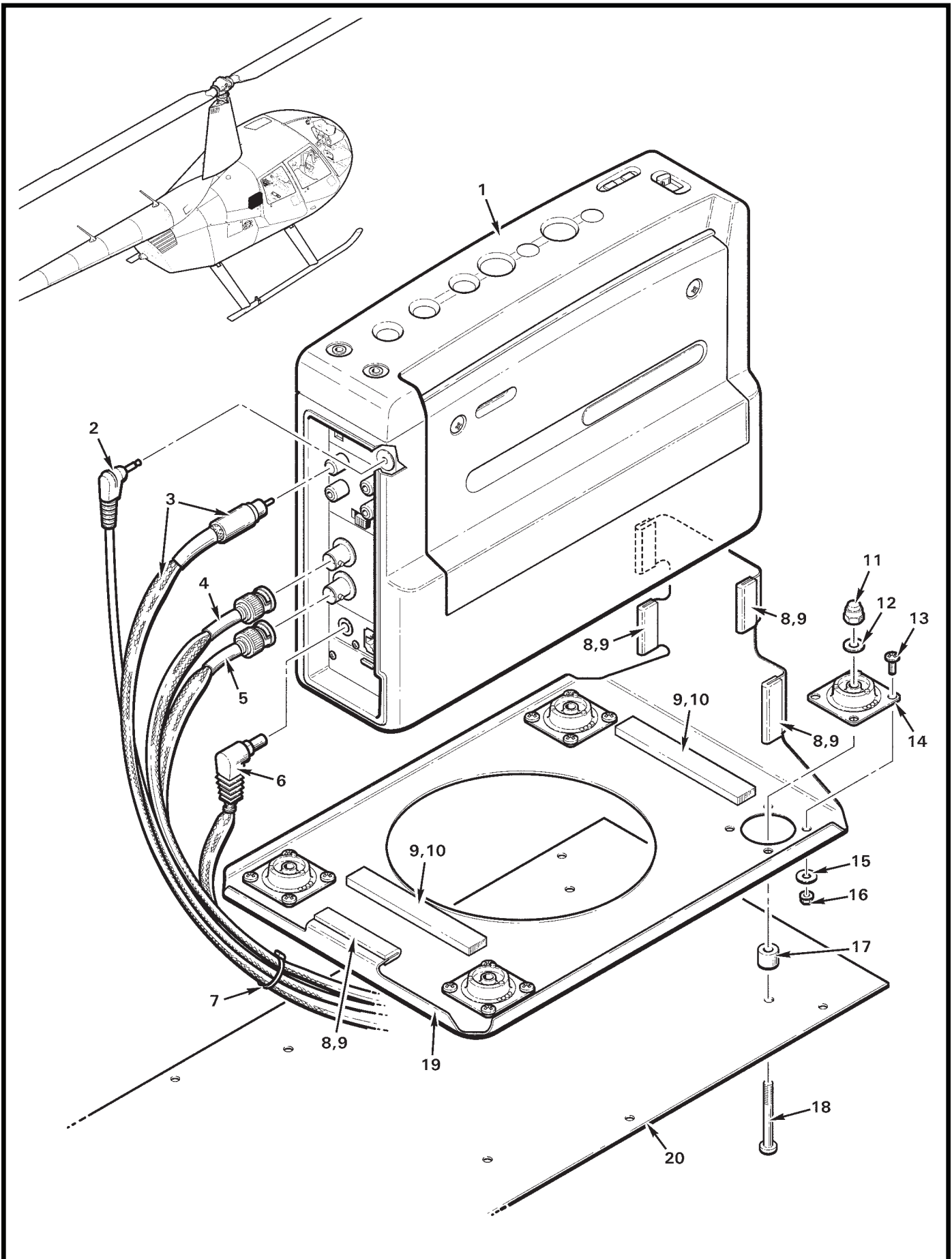

FIGURE AND INDEX NUMBER	PART NUMBER	DESCRIPTION	PARTS AVAIL	QTY PER ASSY
VCR INSTALLATION				
90-17-1	AG-720P*	VCR (VHS, Ref)		
	AG-750P*	VCR (SVHS, Ref)		
2	D421-2	Cable Assembly (Ref)		
3	174-4356	Plug	X	1
	—	Wire (Ref, no. 1388, white)		
	—	Wire (Ref, no. 1389, blue)		
4	D431-794	Cable Assembly (video in)	X	1
5	D431-789	Cable Assembly (video out)	X	1
6	VJAW0037*	Cable - DC (Ref, supplied with VCR)		
7	MS3367-5-9	Ty-Rap	X	A/R
8	A226-9	Moulding (install using item 9)	X	A/R
9	B270-14	Adhesive (or B270-8qt)	X	A/R
10	A226-4	Seal (install using item 9)	X	A/R
11	B340-4	Nut	X	4
12	NAS1149FN832P	Washer	X	4
13	MS35206-227	Screw	X	16
14	106PL-1	Mount	X	4
15	NAS1149FN616P	Washer	X	16
16	MS21042L06	Nut	X	16
17	A130-33	Spacer	X	4
18	MS27039C0822	Screw	X	4
19	D439-1	Tray Assembly (Ref; Includes items 8, 9, 10, 13 thru 16. No longer available.)		
20	C474-2	Cover (Ref)		

NOTES * Panasonic part no.

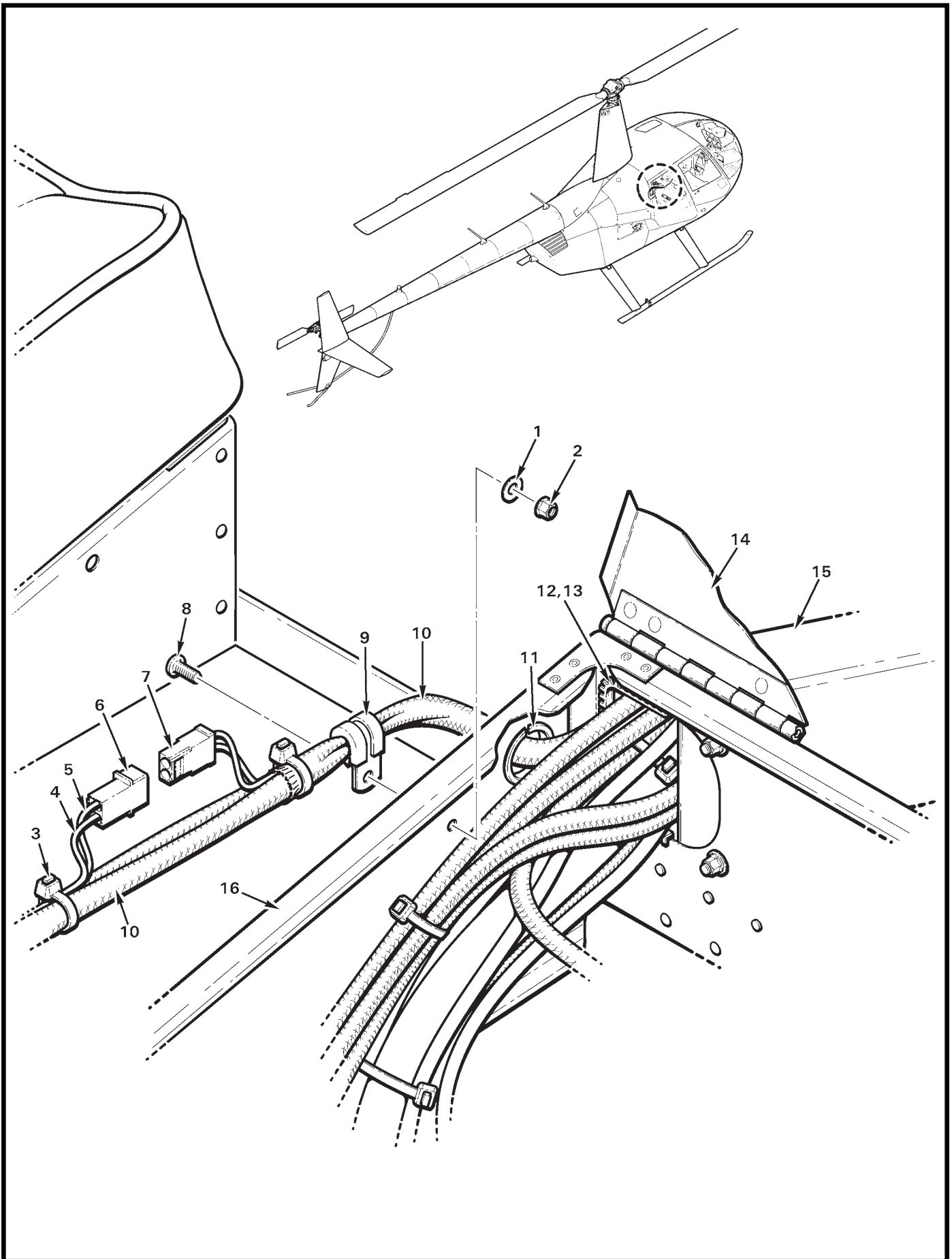

FIGURE AND INDEX NUMBER	PART NUMBER	DESCRIPTION	PARTS AVAIL	QTY PER ASSY
VCR WIRING INSTALLATION				
90-19-1	NAS1149FN832P	Washer	X	1
2	MS21042L08	Nut	X	1
3	MS3367-5-9	Ty-Rap	X	A/R
4	—	Wire (Ref, no. 774)		
5	—	Wire (Ref, no. 773)		
6	B263-12	Housing	X	1
	B263-1	Pin	X	2
7	B263-13	Housing	X	1
	B263-2	Socket	X	2
8	MS27039C0806	Screw	X	1
9	MS21919WDG4	Clamp	X	1
10	B266-4	Sleeving (expandable; 0.25 in. inside dia., nominal)	X	A/R
	B266-8	Sleeving (expandable; 0.50 in. inside dia., nominal)	X	A/R
	B266-12	Sleeving (expandable; 0.75 in. inside dia., nominal)	X	A/R
	B266-20	Sleeving (expandable; 1.25 in. inside dia., nominal)	X	A/R
11	NAS557-12A	Grommet	X	1
12	MS21266-1N	Grommet (install using item 13)	X	1
13	B270-14	Adhesive (or B270-8qt)	X	A/R
14	D670-1	Cover Assembly (Ref, includes C928-5 hinge and D428-8 pin) .	X	1
15	D440	Cover - Auxiliary Wiring (Aft tunnel, Ref)		
16	C291	Support Assembly - Seat Aft (RH, Ref)		

NOTES

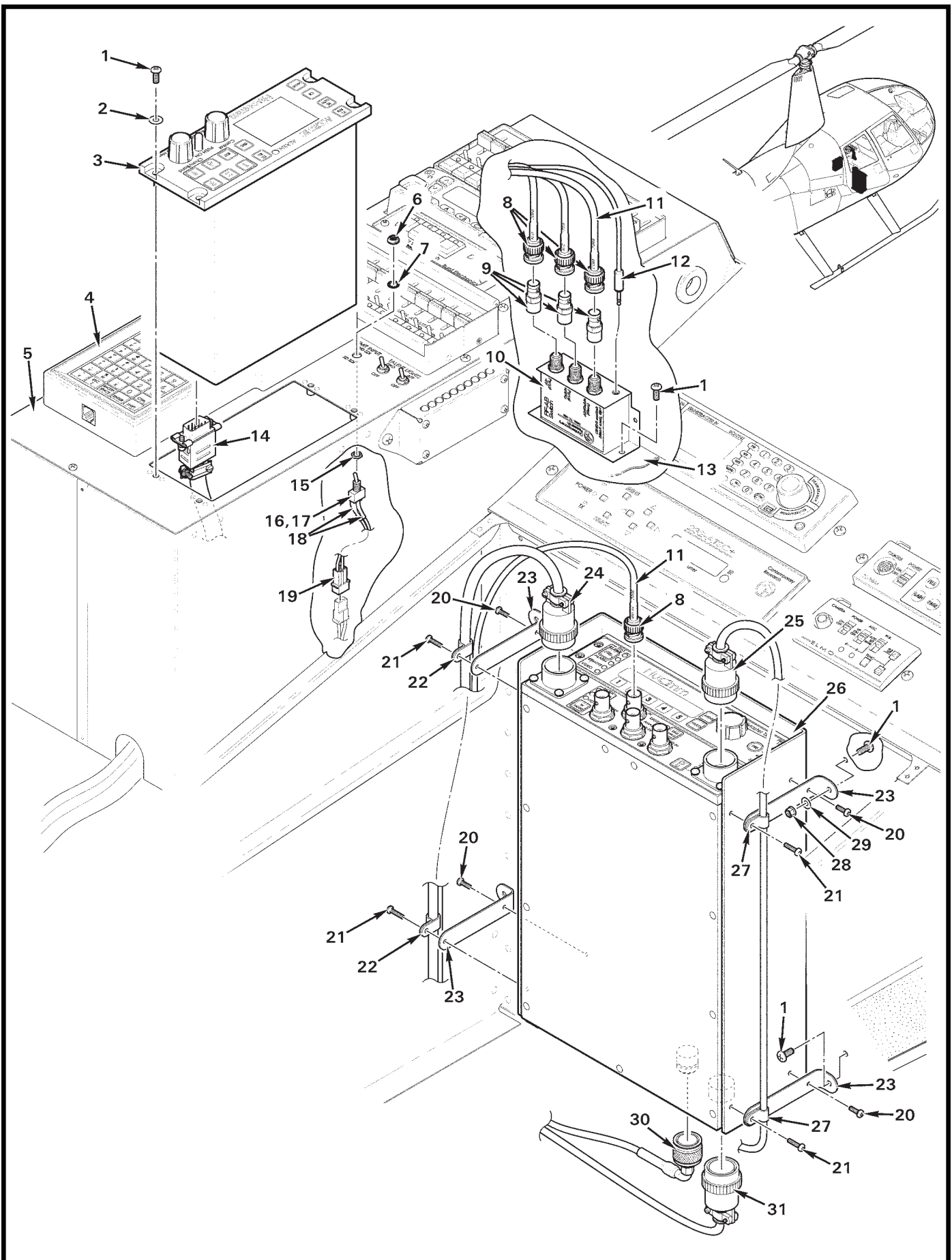

FIGURE AND INDEX NUMBER	PART NUMBER	DESCRIPTION	PARTS AVAIL	QTY PER ASSY
HD MICROWAVE SYSTEM - NUCOMM				
90-21-1	MS27039C0806	Screw	X	10
2	NAS1149FN832P	Washer	X	4
3	ARC-CM-TX-RX-CR-01	Controller	X	1
4	D588-5	Controller (Ref)		
5	D360-1	Console (Ref)		
6	B227-4	Dress Nut	X	1
7	B227-3	Lockwasher	X	1
8	20605-11-9	Plug (Ref)		
9	242199	Adapter	X	3
10	RF-AB	Video Switch	X	1
11	- 2066	Cable (Ref)		
12	171-2035	Plug (Ref)		
13	D650-4	Cover (Ref)		
14	B269	Plug (Ref)		
15	-	Hex Nut	O	1
16	B049-9	Switch Assembly (Includes items 6, 7, 15, 17 thru 19 and wires.)	X	1
17	A123S1YZQ	Switch	X	1
18	B158-1	Heat Shrink	X	A/R
19	B263-12	Housing	X	1
	B263-1	Pin	X	2
20	MS33206-217	Screw	X	4
21	MS35206-215	Screw	X	4
22	8876T18	Clamp	X	2
23	D429-12	Angle	X	4
24	MS316F14-18S	Plug (Ref)		
25	MS316F14-15S	Plug (Ref)		
26	CMTX7-LITE	Transmitter	X	1
27	7622	Clamp	X	2
28	MS21042L08	Nut	X	2
29	NAS1149FN816P	Washer	X	2
30	D766-2379	Cable Assembly (Includes SMA straight plug, Type "N" 90° plug, heat shrink, and microflex 165 cable.)	X	1
31	MS316F14-12S	Plug (Ref)		

NOTES

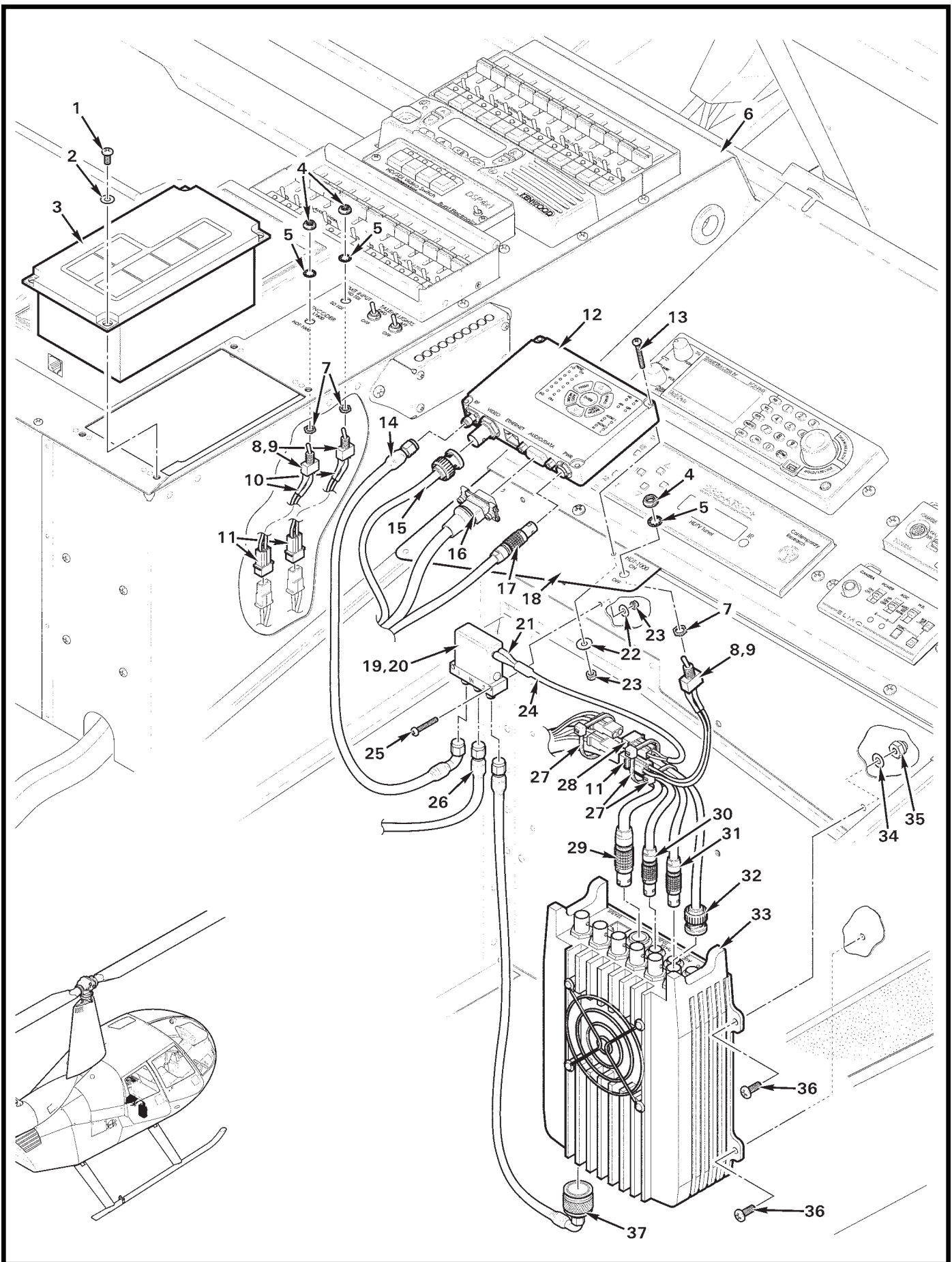

FIGURE AND INDEX NUMBER	PART NUMBER	DESCRIPTION	PARTS AVAIL	QTY PER ASSY
HD MICROWAVE SYSTEM - VISLINK				
90-23-1	MS27039C0806	Screw	X	4
2	NAS1149FN832P	Washer	X	4
3	L1260	Control Panel	X	1
4	B227-3	Lockwasher	X	1
5	B227-4	Dress Nut	X	1
6	D360-1	Console (Ref)		
7	—	Hex Nut	O	1
8	B049-9	Switch Assembly (Includes items 4, 5, 7, 9, 10, 11, and wires.)	X	1
9	A123S1YZQ	Switch	X	1
10	B158-1	Heat Shrink	X	A/R
11	B263-12	Housing	X	1
	B263-1	Pin	X	2
12	HDT-1000	Encoder Transmitter	X	1
13	MS35206-220	Screw	X	3
14	D766-2390	Cable Assembly (Includes 2 SMA 90° plugs, heat shrink, and microflex 165 cable.)	X	1
15	— 2068	Wire (Ref)		
16	MDM-21PH003A	Plug (Ref)		
17	FGG0B304CLAD52	Plug (Ref)		
18	D429-13	Plate	X	1
19	D551-1	Switch Assembly (Includes items 20, 21, 24, 28, and wires.)	X	1
20	D1-413A30	Switch	X	1
21	B158-2	Heat Shrink	X	A/R
22	NAS1149FN416P	Washer	X	5
23	B269	Nut	X	5
24	B158-3	Heat Shrink	X	A/R
25	MS35206-219	Screw	X	2
26	D766-1631	Cable Assembly (Includes SMA straight plug, SMA 90° plug, heat shrink, A729-5 tube, and microflex 165 cable.)	X	1
27	MS3367-5-0	Ty-Rap	X	A/R
28	B263-12	Housing	X	1
	B263-1	Pin	X	2

NOTES

Continues

FIGURE AND INDEX NUMBER	PART NUMBER	DESCRIPTION	PARTS AVAIL	QTY PER ASSY
HD MICROWAVE SYSTEM - VISLINK (Cont'd)				
90-23-29	FGG1B304CLAD62	Plug - 14-volt (Ref)		
30	FGF0B306CLAD52	Plug - Data (Ref)		
31	FGG0B305CLAD52	Plug - Audio (Ref)		
32	D431-754	Cable Assembly (Includes B274-525 video coax, heat shrink, and [2] 2065-11-9 BNC plugs.)	X	1
33	L1600	Encoder Transmitter	X	1
34	NAS1149FN816P	Washer	X	2
35	B340-4	Nut	X	2
36	MS27039C0807	Screw	X	4
37	D766-2379	Cable Assembly (Includes SMA straight plug, Type "N" 90° plug, heat shrink, and microflex 165 cable.)	X	1

NOTES

Intentionally Blank

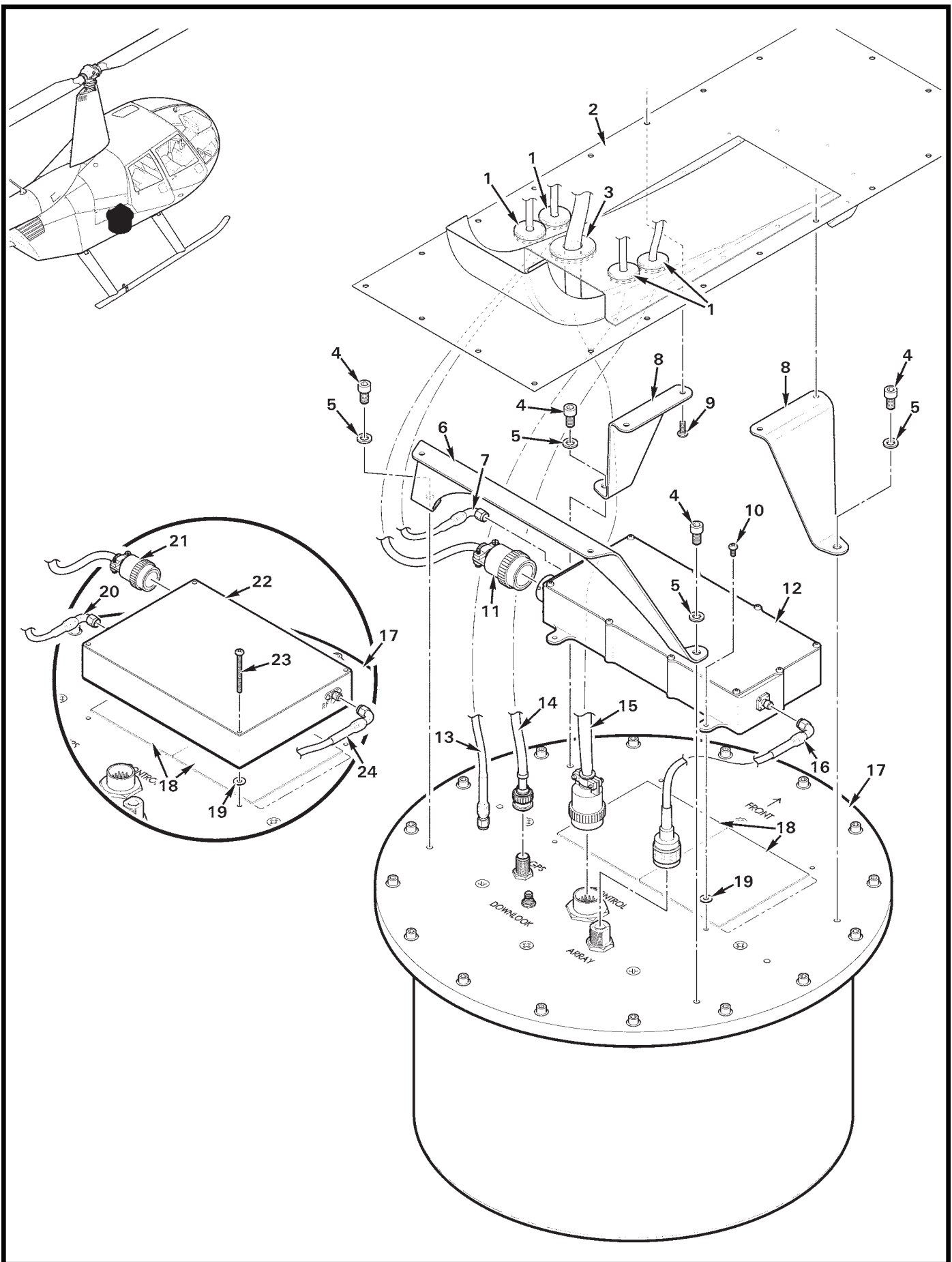

FIGURE AND INDEX NUMBER	PART NUMBER	DESCRIPTION	PARTS AVAIL	QTY PER ASSY
HD MICROWAVE SYSTEM - POD ANTENNA				
90-27-1	MS35489-7	Grommet	X	4
2	C794-3	Panel (Ref)		
3	MS35489-18	Grommet	X	1
4	—	Screw (supplied with item 17)	O	4
5	—	Washer (supplied with item 17)	O	4
6	D586-6	Bracket	X	1
	D586-4	Bracket (Used on D053-3 installation, not shown)	X	1
7	D766-2379	Cable Assembly (includes type "N" 90° plug, SMA plug, heat shrink, and microflex 165 cable.)	X	1
8	D586-5	Bracket	X	2
	D586-3	Bracket (Used on D053-3, not shown.)	X	2
9	MS27039C0807	Screw	X	6
10	MS35206-227	Screw	X	4
11	MS3116F14-12S	Plug (Ref)		
12	D618-1	Amp Assembly (Ref, D056-1 Installation)		
13	D766-1616	Cable Assembly (Ref)		
14	D766-1621	Cable Asssembly - GPS (Ref)		
15	D588-4	Cable Assembly (Ref)		
16	D766-2378	Cable Assemby (Includes SMA 90° plug, type "N" straight plug, and microflex 165 cable)	X	4
17	PA16-__	Pod Antenna	X	1
	PA8-__	Pod Antenna (Used on D053-3 installation, not shown.)	X	1
18	GP1500-0.040-02-0404	Thermal Pad	X	2
19	NAS1149FN632P	Washer	X	4
20	D766-1631	Cable Assembly (Ref)		
21	—	Plug (supplied with item 22)	O	1
22	DPA-200-250-10-43-1228	Power Amp (Ref, D056-2 Installation)	X	1
23	MS35206-236	Screw	X	4
24	D766-1876	Cable Assembly (Includes SMA 90° plug, Type "N" straight plug, heat shrink, and microflex 165 cable.)	X	1

NOTES

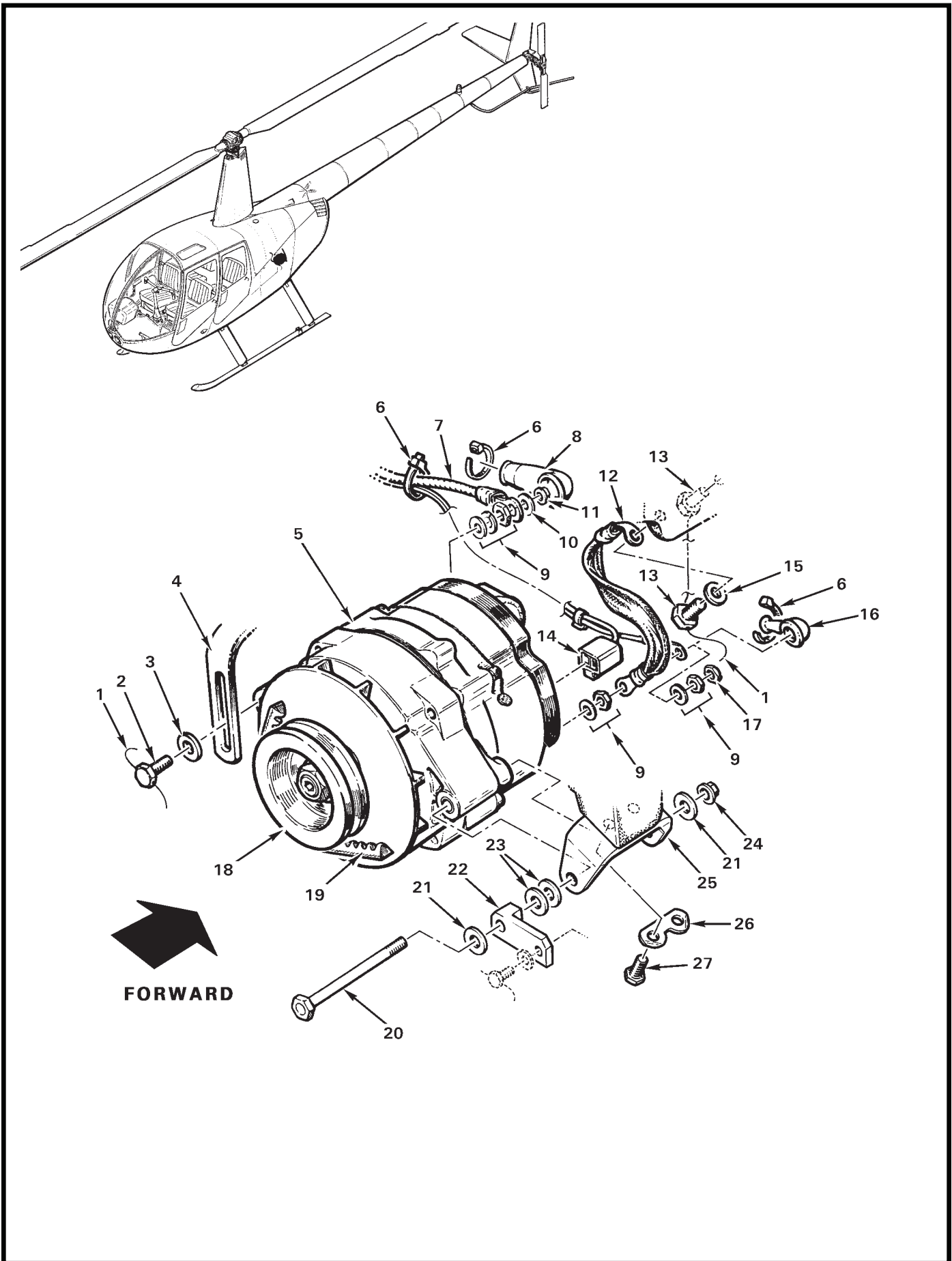

FIGURE AND INDEX NUMBER	PART NUMBER	DESCRIPTION	PARTS AVAIL	QTY PER ASSY
ALTERNATOR INSTALLATION				
90-29-1	MS20995C32	Safety Wire (0.032 in. dia.)	X	A/R
2	LW-31H0.75*	Bolt (Ref; supplied with engine)		
3	STD-1727*	Washer	X	1
4	—	Arm (black; supplied with item 5)	O	1
5	N300P324R(L)	Alternator 70-Amp (Ref; 28-volt Police ships only. National Airparts part no. Incl items 4, 9, and 18. Superseded; for Police ships see Figure 71-59 [D729-1; 130-Amp], for ENG Figure 71-51 [D748-1; 70-Amp Kelly Aerospace].)	O	1
6	MS3367-4-9	Ty-Rap	X	3
7	A780-36	Cable Assembly (aft and tailcone battery)	X	1
	A780-37	Cable Assembly (forward and under seat battery)	X	1
8	MS25171-2S	Nipple	X	1
9	—	Hardware (supplied with item 5)	O	1
10	NAS1149F0432P	Washer	X	1
11	MS21042L4	Nut	X	1
12	A780-13	Cable Assembly (ground; Ref)		
13	MS20074-05-04	Bolt	X	2
14	N502	Housing (Ref, no longer available)		
	N1340	Receptacle (Ref, no longer available)		
15	NAS1149F0532P	Washer	X	2
16	MS25171-1S	Nipple	X	1
17	B330-12	Palnut	X	1
18	—	Pulley (supplied with item 5)	X	1
19	B173-1**	V-Belt	X	1
20	NAS6606-50	Bolt	X	2
21	—	Washer (supplied with engine)	O	2
22	B299-2	Link (use only with item 5)	X	1
23	—	Washer (as required for shimming; supplied with engine)	X	A/R
24	MS21042L6	Nut	X	2
25	74324*	Bracket	X	1
26	73383*	Lockplate	X	1
27	LW-31-0.94*	Bolt	X	2

NOTES * Lycoming part no.
 ** Use with 31M21951* ring gear.

Intentionally Blank

CHAPTER 92

ELECTRONIC NEWS GATHERING (ENG) VERSION

<u>Figure</u>	<u>Title</u>	<u>Page</u>
92-1	Camera and Gimbal Installation	92.0
92-3	Camera and Gimbal Fairing and Cover	92.2
92-5	Camera and Gimbal Installation	92.4
92-7	Camera and Gimbal Fairing and Cover	92.6
92-9	Micro Camera Installation – Windshield	92.8
92-11	Micro Camera Installation – Mid Cabin	92.10
92-13	Micro Camera Installation – Aft Cabin	92.12
92-15	Micro Camera Installation – Horizontal Stabilizer	92.14
92-17	Aft Monitors Installation	92.16
92-17B	Aft Monitors Installation	92.17A I
92-19	Microwave Antenna Installation	92.18
92-21	Geneva Audio – Pilot Audio Panel	92.20
92-23	Geneva Audio – Co-Pilot Audio Panel	92.22
92-25	Geneva Audio – Aft Audio Panels	92.24
92-27	Geneva Audio – Digital Router	92.26
92-29	Geneva Audio – Transmit Switch	92.28
92-31	Geneva Audio – Backplane Installation	92.30
92-35	Geneva Audio – Backplane Components	92.34
92-37	Forward Monitors Installation	92.36

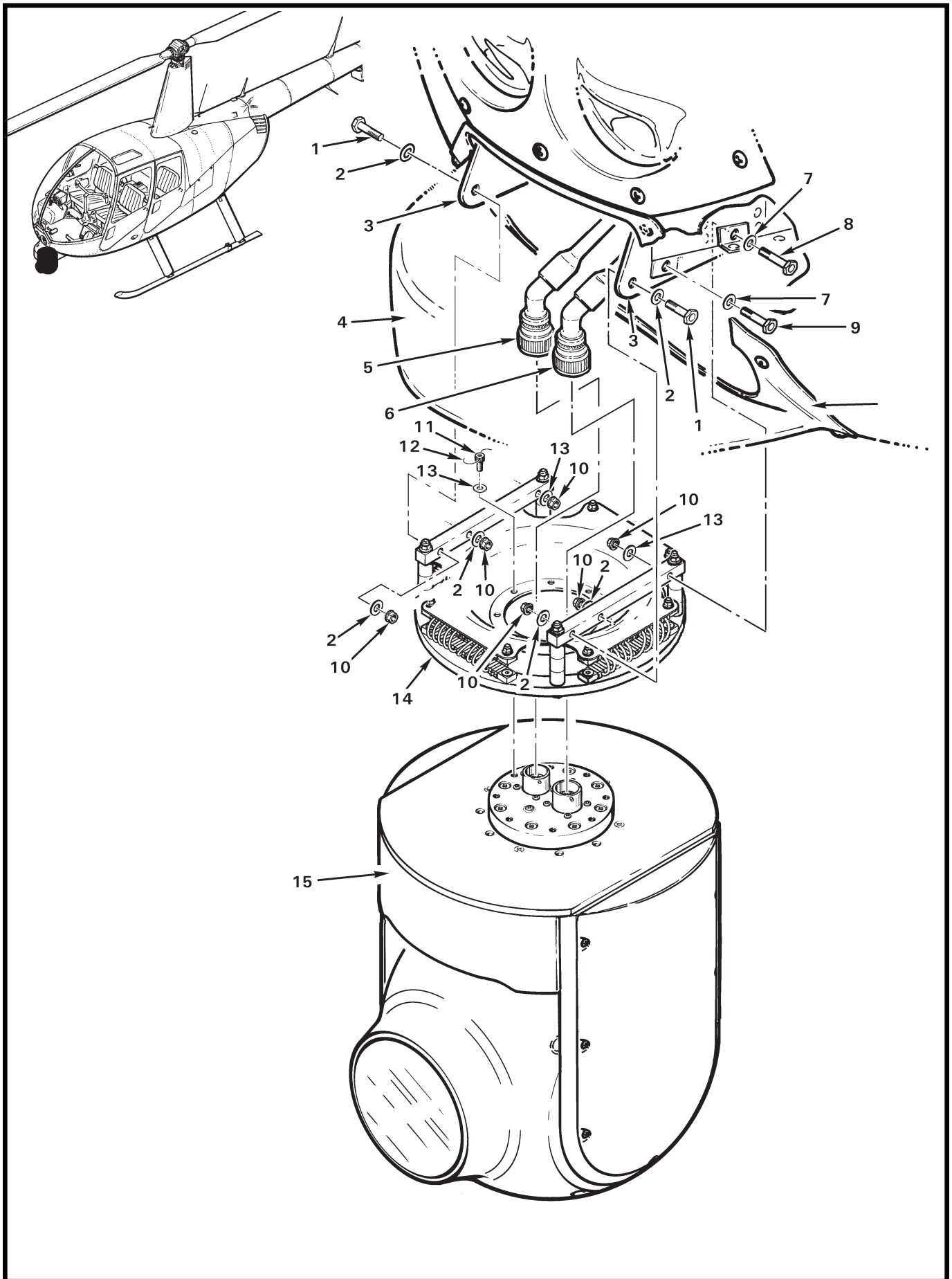

FIGURE AND INDEX NUMBER	PART NUMBER	DESCRIPTION	PARTS AVAIL	QTY PER ASSY
CAMERA AND GIMBAL INSTALLATION				
92-1-1	NAS6604-8	Bolt	X	2
2	NAS1149F0432P	Washer	X	6
3	D349-1	Support	X	2
4	D427-1	Fairing (Ref, see Figure 92-3)		
5	E204-1	Cable (camera)	X	1
6	E195-1	Cable (turret)	X	1
7	A141-11	Washer	X	4
8	NAS6604-12	Bolt	X	2
9	NAS6604-11	Bolt	X	2
10	MS21042L4	Nut	X	6
11	NAS1351-3H6P	Screw	X	8
12	MS20995C32	0.032 in. dia. Safety Wire	X	A/R
13	NAS1149F0332P	Washer	X	8
14	D385-1	Mount Assembly	X	1
15	E001-1	Gimbal Assembly (Ref)		

NOTES

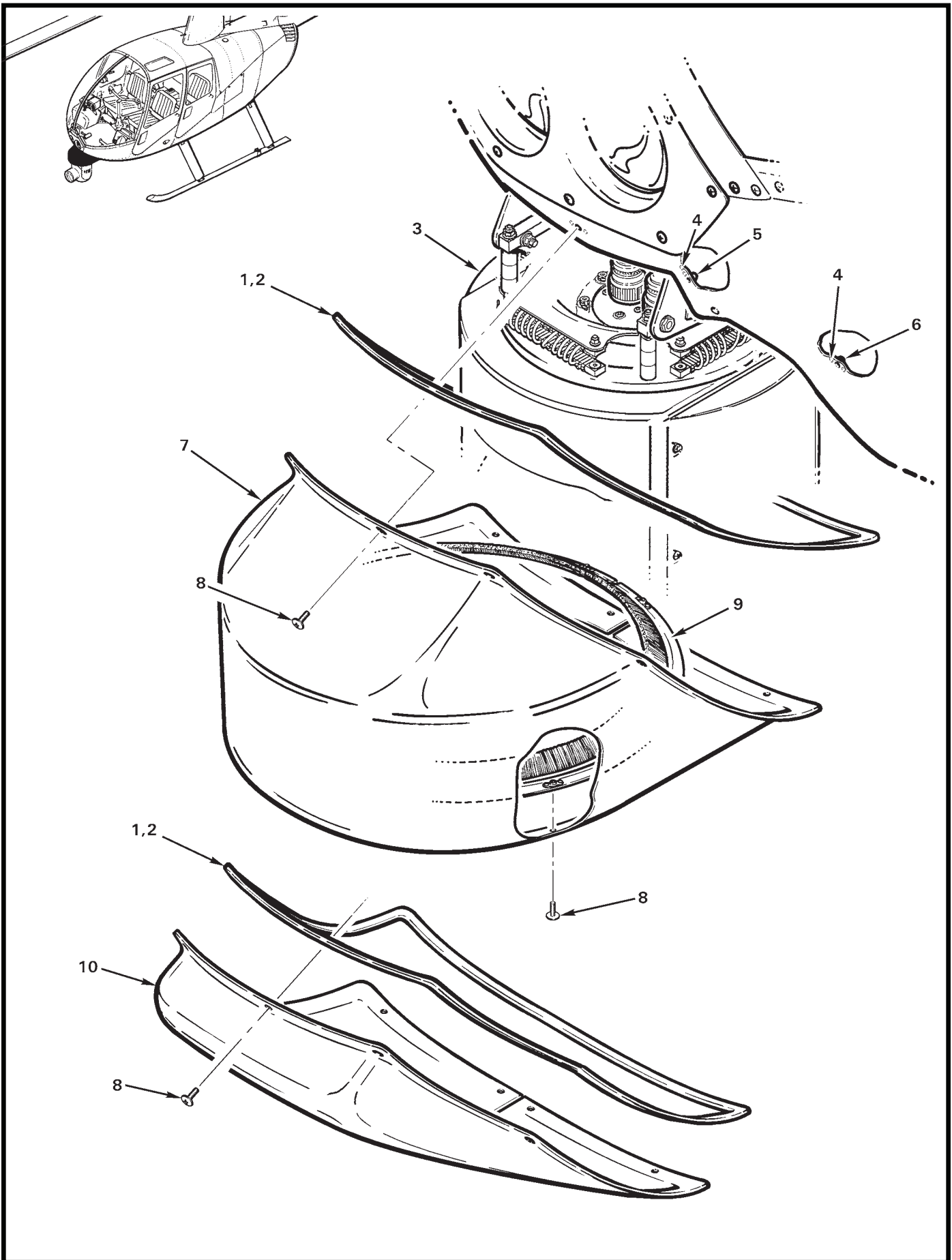

FIGURE AND INDEX NUMBER	PART NUMBER	DESCRIPTION	PARTS AVAIL	QTY PER ASSY
CAMERA AND GIMBAL FAIRING AND COVER				
92-3-1	A226-3	Seal (install using item 2)	X	A/R
2	B270-4	Sealant (silicone)	X	A/R
3	—	Gimbal Assembly (Ref)		
4	NAS1097AD3	Rivet	X	24
5	MS21071L08	Nutplate	X	2
6	MS21069L08	Nutplate	X	10
7	D427-1	Fairing	X	1
8	AN526C832R7	Screw	X	20
9	D351-1	Seal Assembly	X	1
10	D427-2	Cover (for use when item 3 is removed)	X	1

NOTES

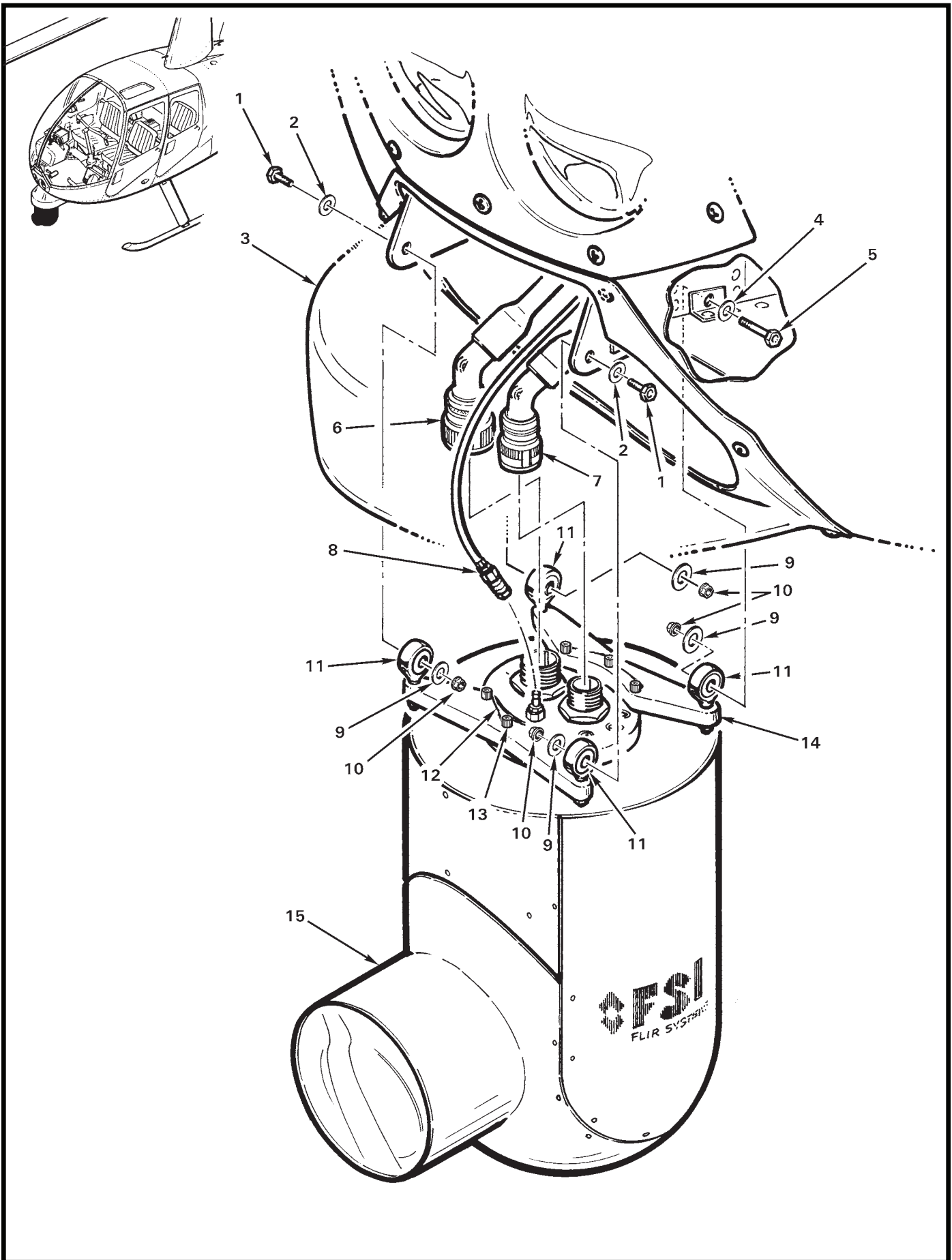

FIGURE AND INDEX NUMBER	PART NUMBER	DESCRIPTION	PARTS AVAIL	QTY PER ASSY
CAMERA AND GIMBAL INSTALLATION				
92-5-1	NAS6604-8	Bolt	X	2
2	NAS1149F0432P	Washer	X	2
3	D347-1	Fairing (Ref, see Figure 92-7)		
4	A141-11	Washer	X	2
5	NAS6604-12	Bolt	X	2
6	24607080-2/100	Cable - Gimbal Control/Power (Ref)		
7	24607070-2/100	Cable - Gimbal Camera (Ref)		
8	—	Tube (Ref, to desiccant canister)		
9	A214-3	Washer	X	4
10	MS21042L4	Nut	X	4
11	D597-1	Rod End (red dot)	X	4
	D597-2	Rod End (yellow dot)	X	4
	D597-4	Rod End (blue dot)	X	4
12	MS20995C32	0.032 in. dia. Safety Wire	X	A/R
13	NAS1351-3H14P	Screw (drilled head)	X	6
14	D558-1	Plate	X	2
15	94001002-1	Gimbal Assembly (Ref, NTSC system)		
	94001002-2	Gimbal Assembly (Ref, PAL system)		

NOTES

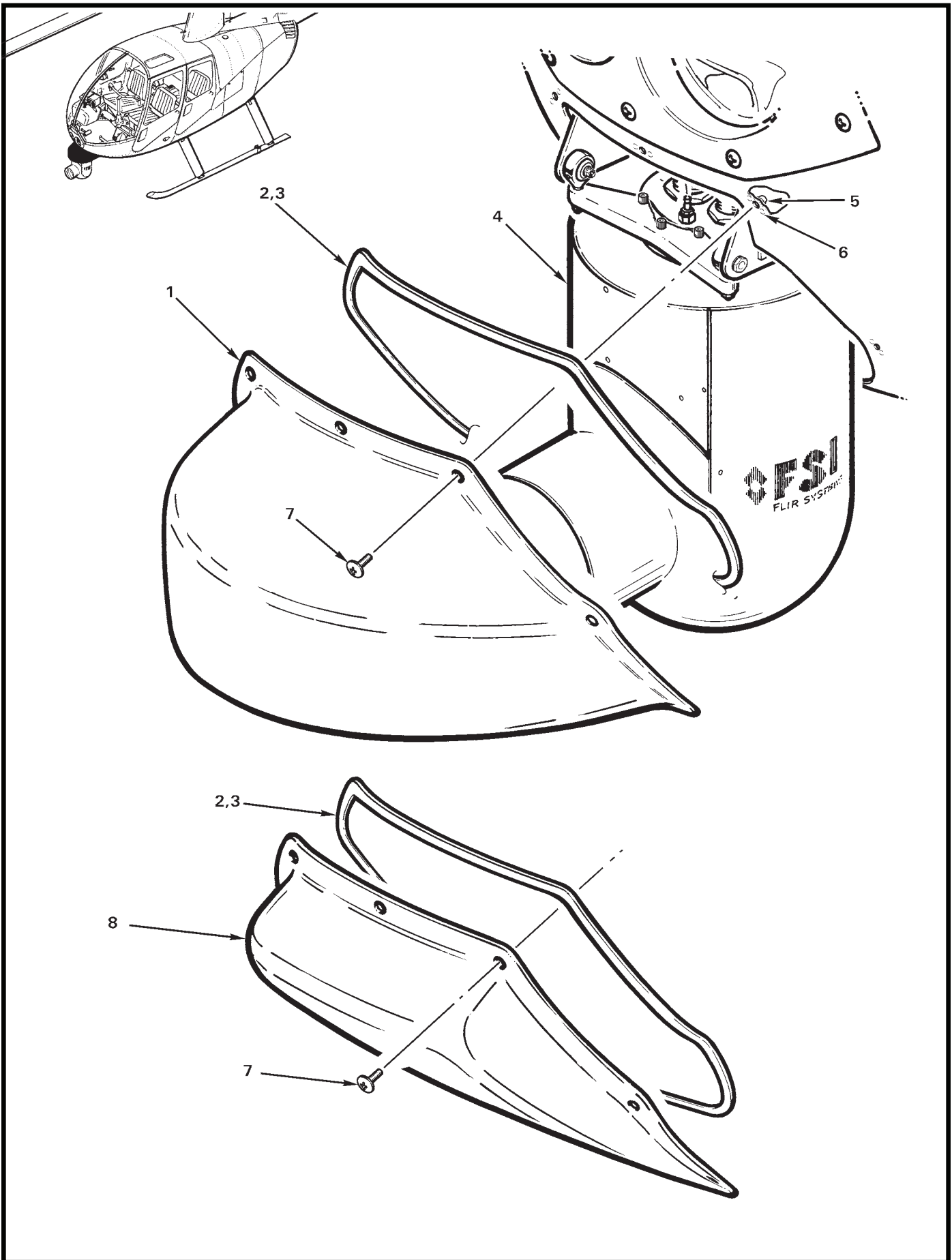

FIGURE AND INDEX NUMBER	PART NUMBER	DESCRIPTION	PARTS AVAIL	QTY PER ASSY
CAMERA AND GIMBAL FAIRING AND COVER				
92-7-1	D347-1	Fairing	X	1
2	A226-3	Seal (install using item 3)	X	A/R
3	B270-4	Sealant (silicone)	X	A/R
4	—	Gimbal Assembly (FSI; Ref)		
5	MS21069L08	Nutplate	X	12
6	MS20426AD3	Rivet	X	24
7	AN526C832R7	Screw	X	12
8	D347-2	Cover (for use when item 4 is removed)	X	1

NOTES

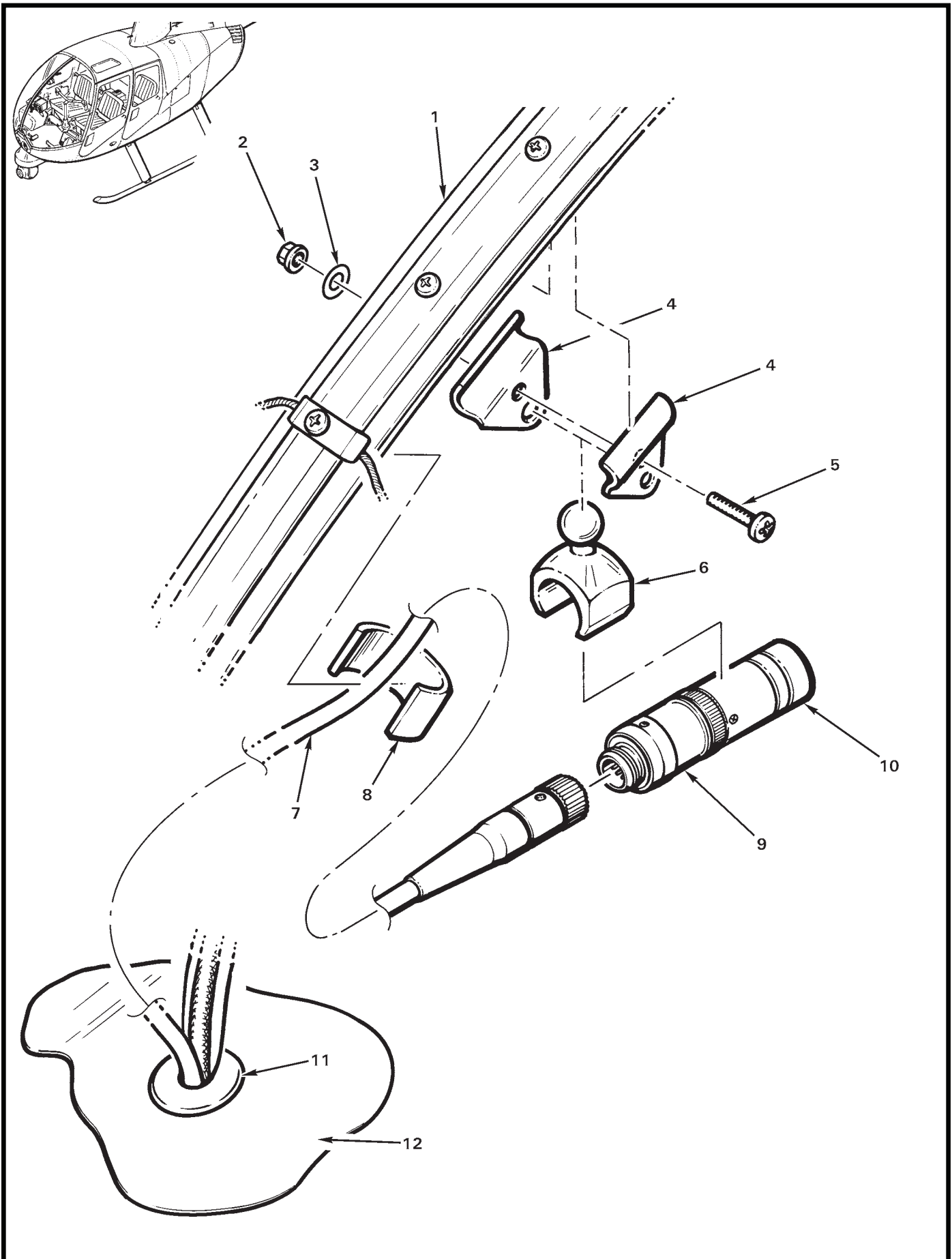

FIGURE AND INDEX NUMBER	PART NUMBER	DESCRIPTION	PARTS AVAIL	QTY PER ASSY
MICRO CAMERA INSTALLATION - WINDSHIELD				
92-9-1	C238	Bow - Windshield (Ref)		
2	MS21042L08	Nut	X	1
3	NAS1149FN816P	Washer	X	1
4	D368-2	Clamp	X	2
5	MS27039C0811	Screw	X	1
6	D368-1	Clip	X	1
7	D572-3	Cable - Camera	X	1
8	D368-6	Clip (as required, 4 maximum)	X	A/R
9	MN43H	Camera	X	1
10	9250	Lens - Camera	X	1
11	MS35489-16	Grommet	X	1
12	B050	Console Assembly (Ref)		

NOTES

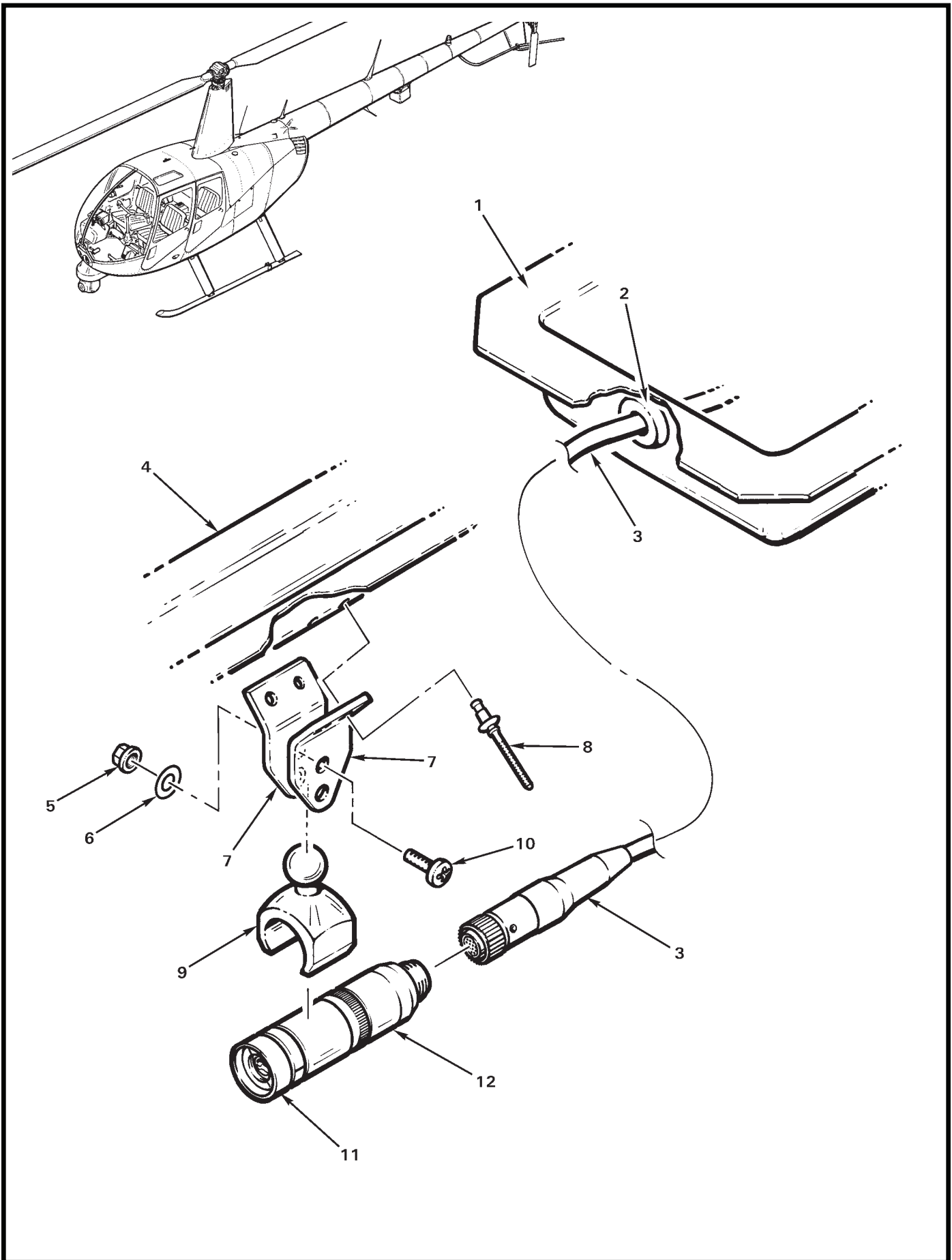

FIGURE AND INDEX NUMBER	PART NUMBER	DESCRIPTION	PARTS AVAIL	QTY PER ASSY
MICRO CAMERA INSTALLATION - MID CABIN				
92-11-1	A712	Cover (Ref)		
2	MS35489-6	Grommet	X	1
3	EMC-03H	Cable - Camera	X	1
4	C238-23	Support (Ref)		
5	MS21042L08	Nut	X	1
6	NAS1149FN816P	Washer	X	1
7	D368-7	Clamp	X	2
8	NAS1919B04S02	Rivet	X	4
9	D368-1	Clip	X	1
10	MS27039C0811	Screw	X	1
11	9264	Lens - Camera	X	1
12	MN43H	Camera	X	1
NOTES				

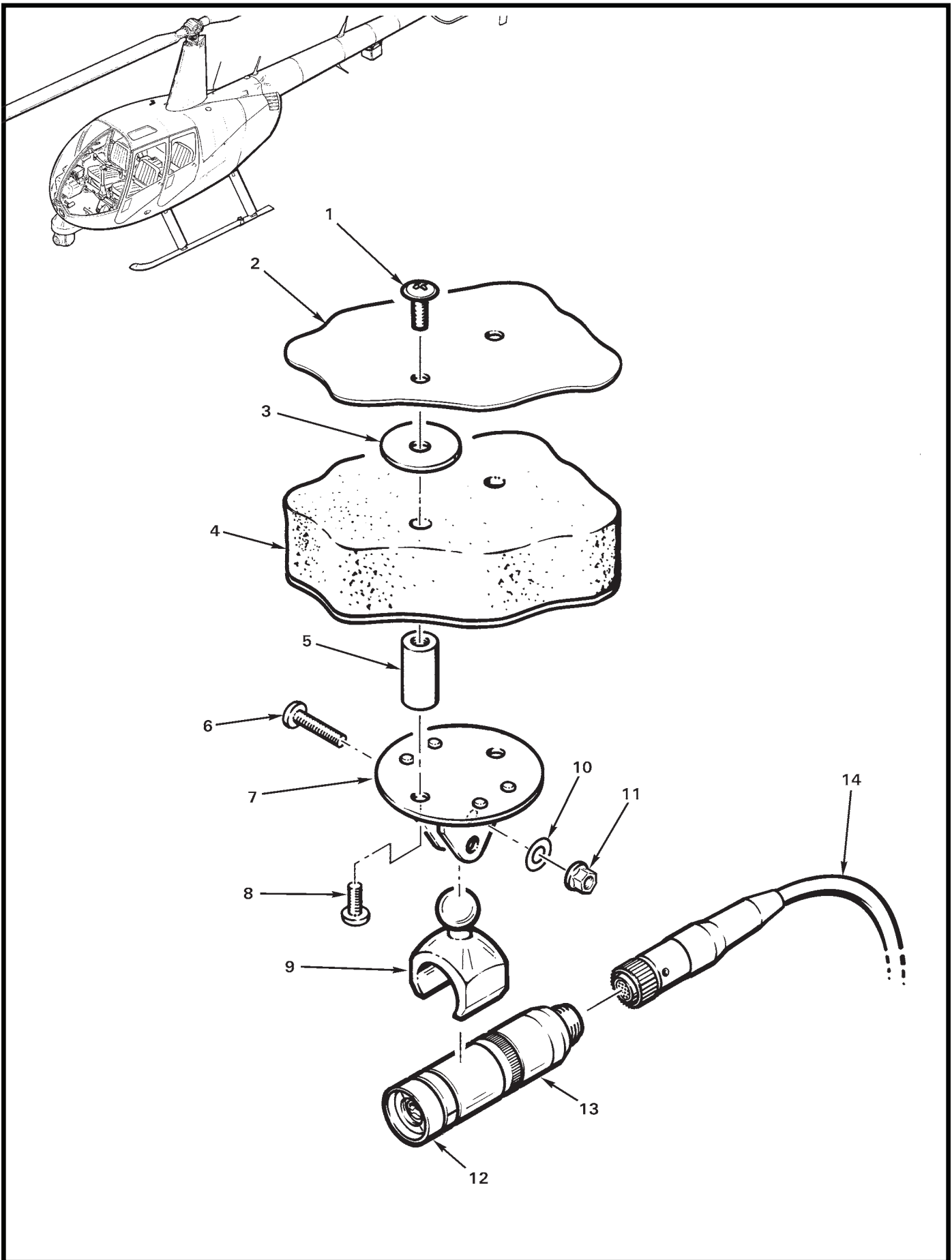

FIGURE AND INDEX NUMBER	PART NUMBER	DESCRIPTION	PARTS AVAIL	QTY PER ASSY
MICRO CAMERA INSTALLATION - AFT CABIN				
92-13-1	AN526C832R7	Screw	X	2
2	—	Panel - Roof (Ref)		
3	AN970-3	Washer	X	2
4	B298	Foam Insulation (Ref)		
5	C710-3	Spacer	X	2
6	MS27039C0810	Screw	X	1
7	D368-3	Mount Assembly	X	1
8	MS27039C0805	Screw	X	2
9	D368-1	Clip	X	1
10	NAS1149FN816P	Washer	X	1
11	MS210421L08	Nut	X	1
12	9250	Lens - Camera	X	1
13	MN43H	Camera	X	1
14	EMC-03H	Cable - Camera	X	1

NOTES

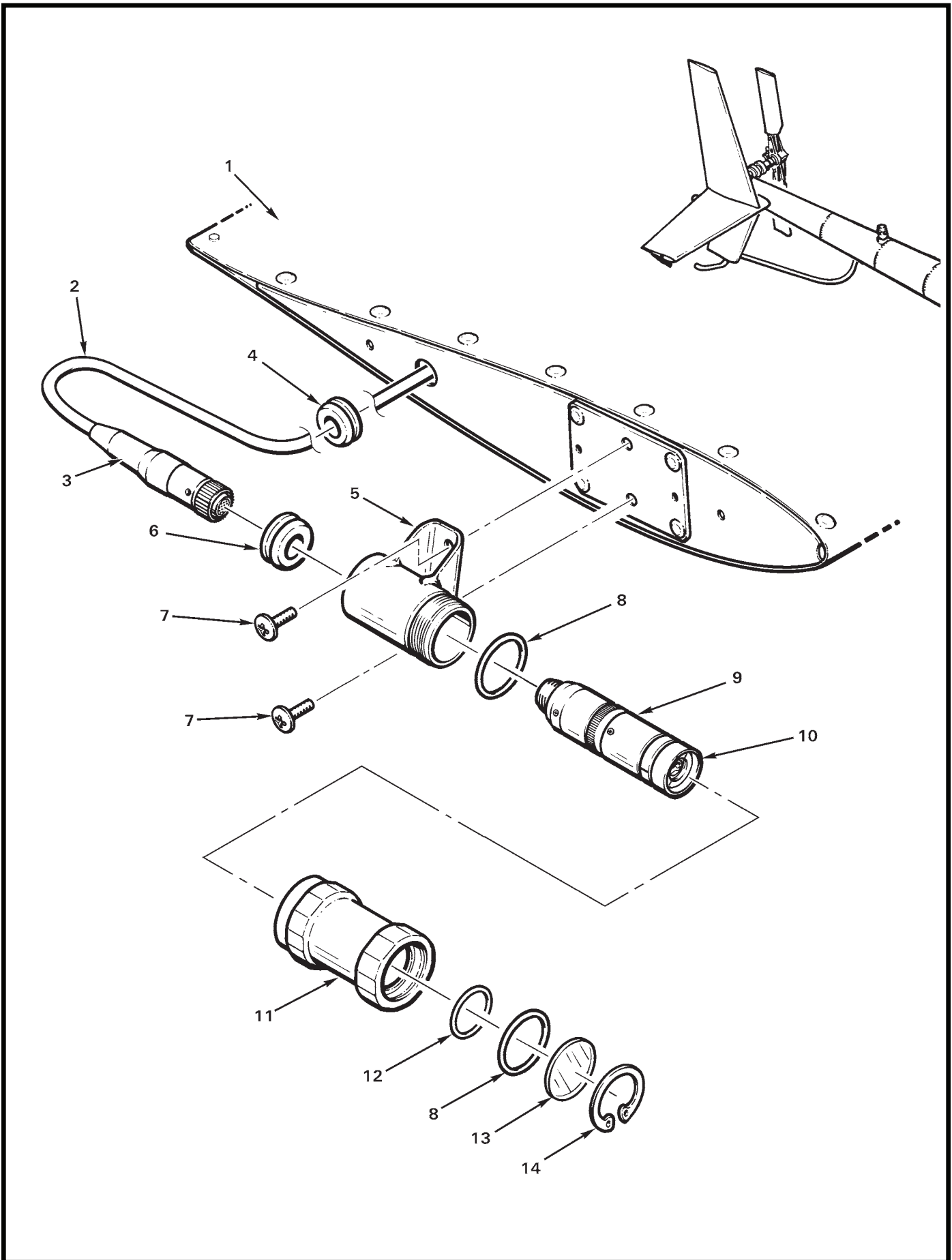

FIGURE AND INDEX NUMBER	PART NUMBER	DESCRIPTION	PARTS AVAIL	QTY PER ASSY
		MICRO CAMERA INSTALLATION* - HORIZONTAL STABILIZER		
92-15-1	D097-11	Stabilizer Assembly - Horizontal (Ref, see Figure 53-33)		
2	D572-4	Cable - Camera (Ref)		
3	B158-6	Heat Shrink	X	A/R
4	MS35489-9	Grommet (Ref)	X	1
5	D397-15	Base Assembly	X	1
6	MS35489-147X	Grommet	X	1
7	AN526C832R7	Screw	X	2
8	A215-017	O-Ring	X	2
9	IK-M44H	Camera (Ref; Contact RHC Technical Support for replacement)		
	MN43H	Camera (for earlier ENG R44s)	X	1
10	9250	Lens	X	1
11	D397-16	Cap	X	1
12	A215-016	O-Ring	X	1
13	A43368	Window	X	1
14	WHT-81-S02	Retaining Ring	X	1

NOTES * Standard defintion camera installation shown.

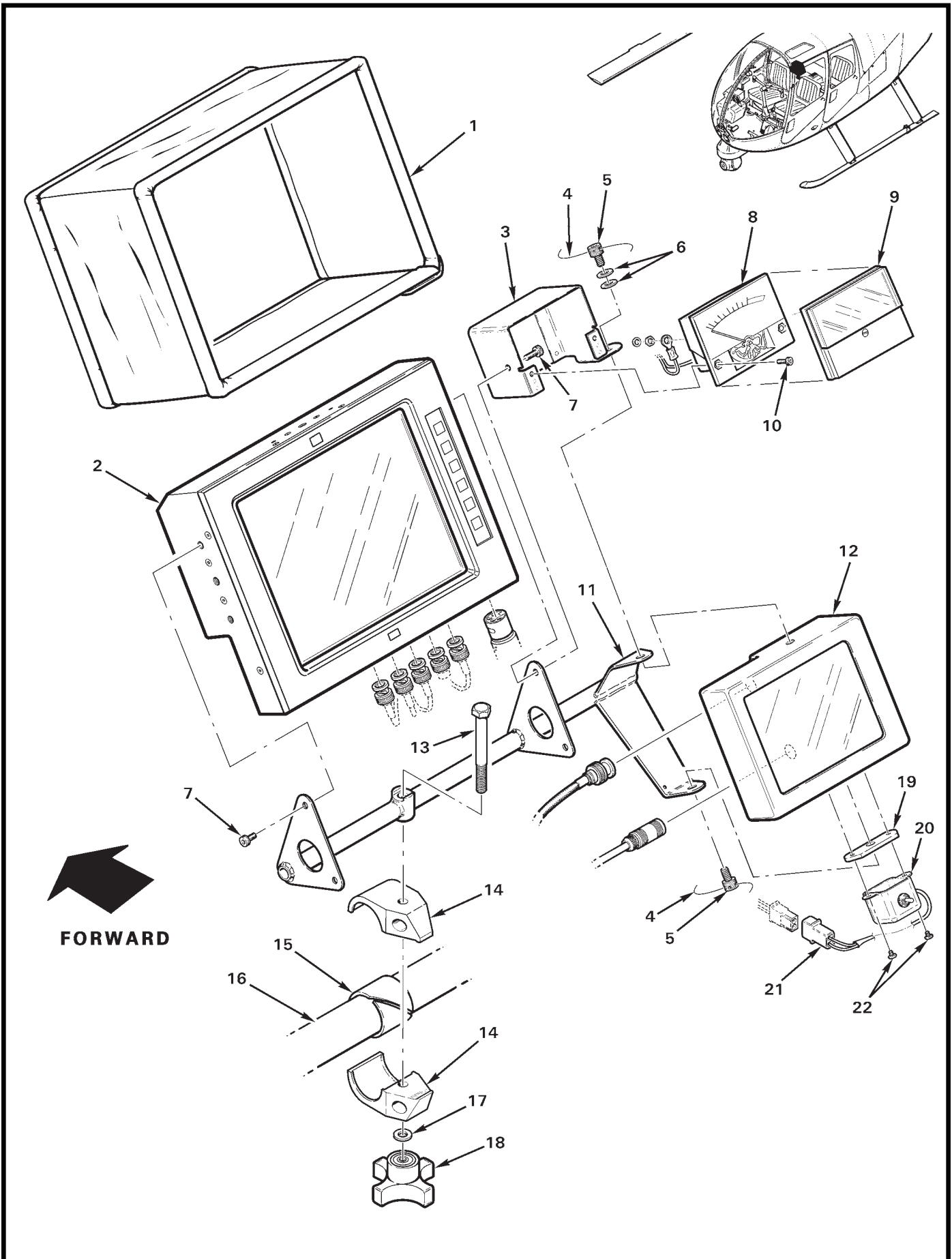

FIGURE AND INDEX NUMBER	PART NUMBER	DESCRIPTION	PARTS AVAIL	QTY PER ASSY
AFT MONITORS INSTALLATION				
92-17-1	9HOOD8S	Hood (8.40 inch, black)	X	1
2	FPM8R300	Monitor (7.00 inch)	X	1
3	D448-5	Box Assembly	X	1
	D448-7*	Box Assembly	X	1
4	MS20995C20	0.020 in. dia. Safety Wire	X	A/R
5	NAS1352-4H6P	Screw	X	16
6	NAS1149F0463P	Washer (one or two, A/R)	X	A/R
7	91290A140	Screw	X	4
8	R5457	VU Meter (analog, vendor part no. 2LLAS-AVU-000-BW-Z; includes item 9)	X	1
9	—	Cover – Meter (Ref)		
10	NAS1352-06H6P	Screw	X	2
11	D444-7	Weldment	X	1
	D444-11*	Weldment	X	1
12	D656-1	Monitor (5.00 inch)	X	1
	D656-2*	Monitor (5.00 inch)	X	1
13	91257A553	Cap Screw	X	1
14	D345-1	Clamp	X	2
15	20L18-D	Bearing	X	1
16	C423-1	Tube – Seat Back (forward; Ref)		
17	NAS1149F0463P	Washer	X	1
18	2830	Knob	X	1
19	D565-7	Mount	X	1
20	D565-5	Switch Assembly	X	1
21	B263-32	Housing (black)	X	1
	B263-1	Pin	X	2
22	MS35206-211	Screw	X	2

NOTES * Not shown. Used with PAL components.

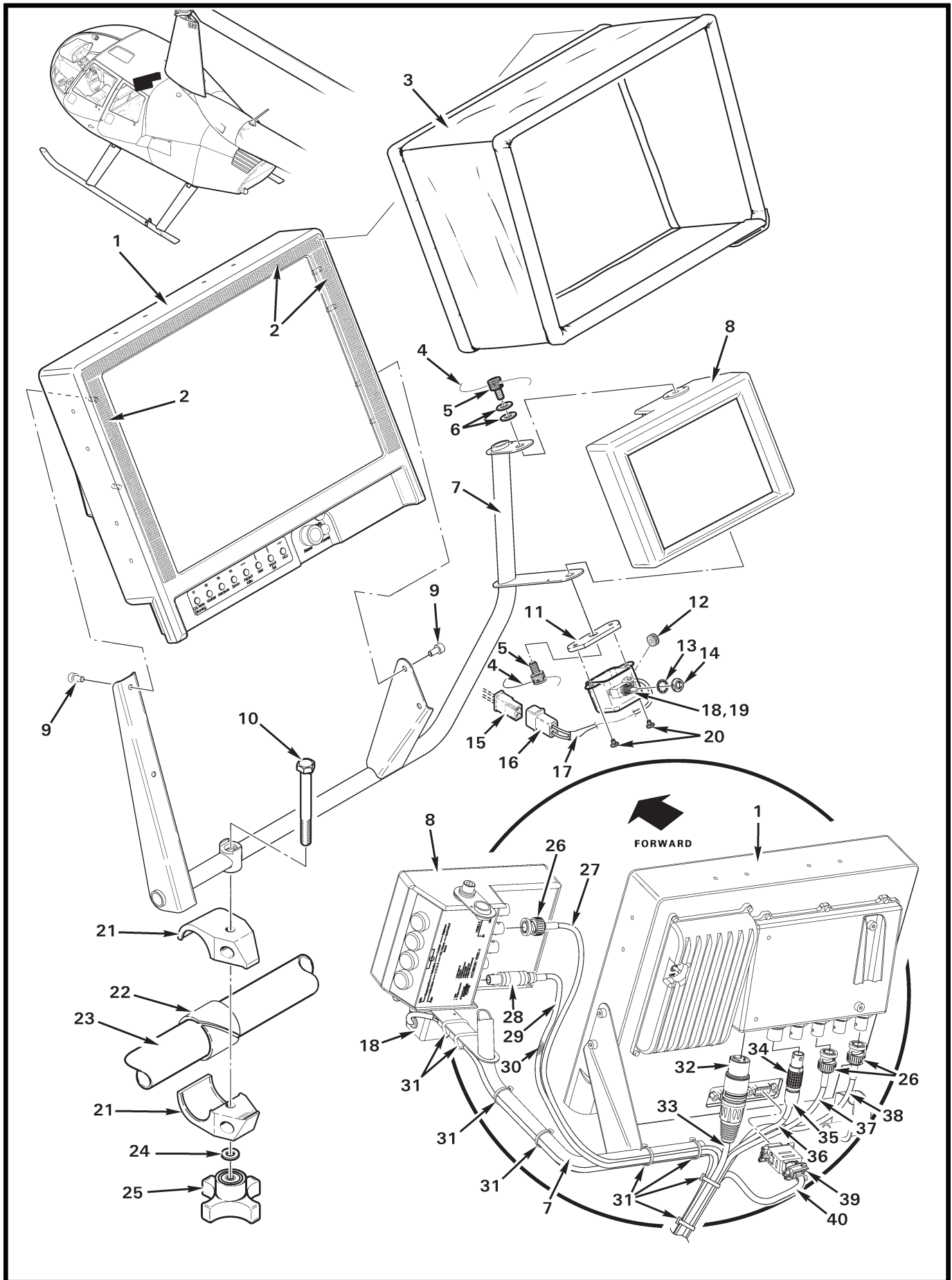

FIGURE AND INDEX NUMBER	PART NUMBER	DESCRIPTION	PARTS AVAIL	QTY PER ASSY
AFT MONITORS INSTALLATION				
92-17B-1	HD10CINEROB	Monitor (10.00 inch)	X	1
2	—	Hook Tape (velcro, self adhesive)	O	1
3	H10R	Visor (Incl item 2)	X	1
4	MS20995C20	0.020 in. dia Safety Wire	X	A/R
5	NAS1352-4H6P	Screw	X	2
6	NAS1149F0463P	Washer (2 maximum)	X	A/R
7	D444-25	Support Weldment	X	1
8	D656-4	Monitor (6.50 inch)	X	1
9	91290A140	Screw	X	4
10	91257A553	Cap Screw	X	1
11	D565-7	Mount	X	1
12	MS35489-1	Grommet	X	1
13	—	Lockwasher	X	1
14	B227-4	Dress Nut	X	1
15	B263-33	Housing	X	1
	B263-2	Socket	X	2
16	B263-32	Housing	X	1
	B263-1	Pin	X	2
17	B158-2	Heat Shrink	X	A/R
18	D565-5	Switch Assembly (Incl items 12, 16, 17, and 19)	X	1
19	B300-3	Switch (Incl items 13 and 14)	X	1
20	MS35206-211	Screw	X	2
21	D345-1	Clamp	X	2
22	20L18-D	Bearing	X	1
23	C423-1	Tube Weldment (Ref, forward seat backs)		
24	NAS1149F0463P	Washer	X	1
25	2830	Knob	X	1
26	2065-11-9	Plug (or 2025-47-9; BNC)	X	2
27	D059-1835	Wire (Ref; "COMPOS IN")		
28	FFAIS302CLAC57	Connector	X	1
	B158-1	Heat Shrink (not shown)	X	A/R
	B267-2	Terminator (not shown)	X	2
NOTES				
Continues				

FIGURE AND INDEX NUMBER	PART NUMBER	DESCRIPTION	PARTS AVAIL	QTY PER ASSY
AFT MONITORS INSTALLATION (Cont'd)				
92-17B-29	D059-909	Wire (Ref)		
	D059-976	Wire (Ref)		
30	B266-4	Sleeving	X	A/R
31	MS3367-4-0	Ty-rap (black)	X	A/R
32	NC4FX	Plug	X	1
	B158-2	Heat Shrink (not shown)	X	A/R
	B267-2	Terminator (not shown)	X	2
33	D059-897	Wire (Ref)		
	D059-975	Wire (Ref)		
34	FGG1B308CLAD62	Plug	X	1
	2843/19	Wire (drain; not shown)	O	1
35	B158-8	Heat Shrink (1.50-inch length)	X	1
36	D059-1622	Wire (Ref)		
	D059-1623	Wire (Ref)		
	D059-1624	Wire (Ref)		
37	D059-760	Wire (Ref; SDI 1)		
38	D059-765	Wire (Ref; SDI 2)		
39	B269-1	Plug (9-pin)	X	1
	B269-21	Backshell	X	1
40	D059-2350	Wire (Ref)		
	D059-2351	Wire (Ref)		
	D059-2352	Wire (Ref)		

NOTES

Intentionally Blank

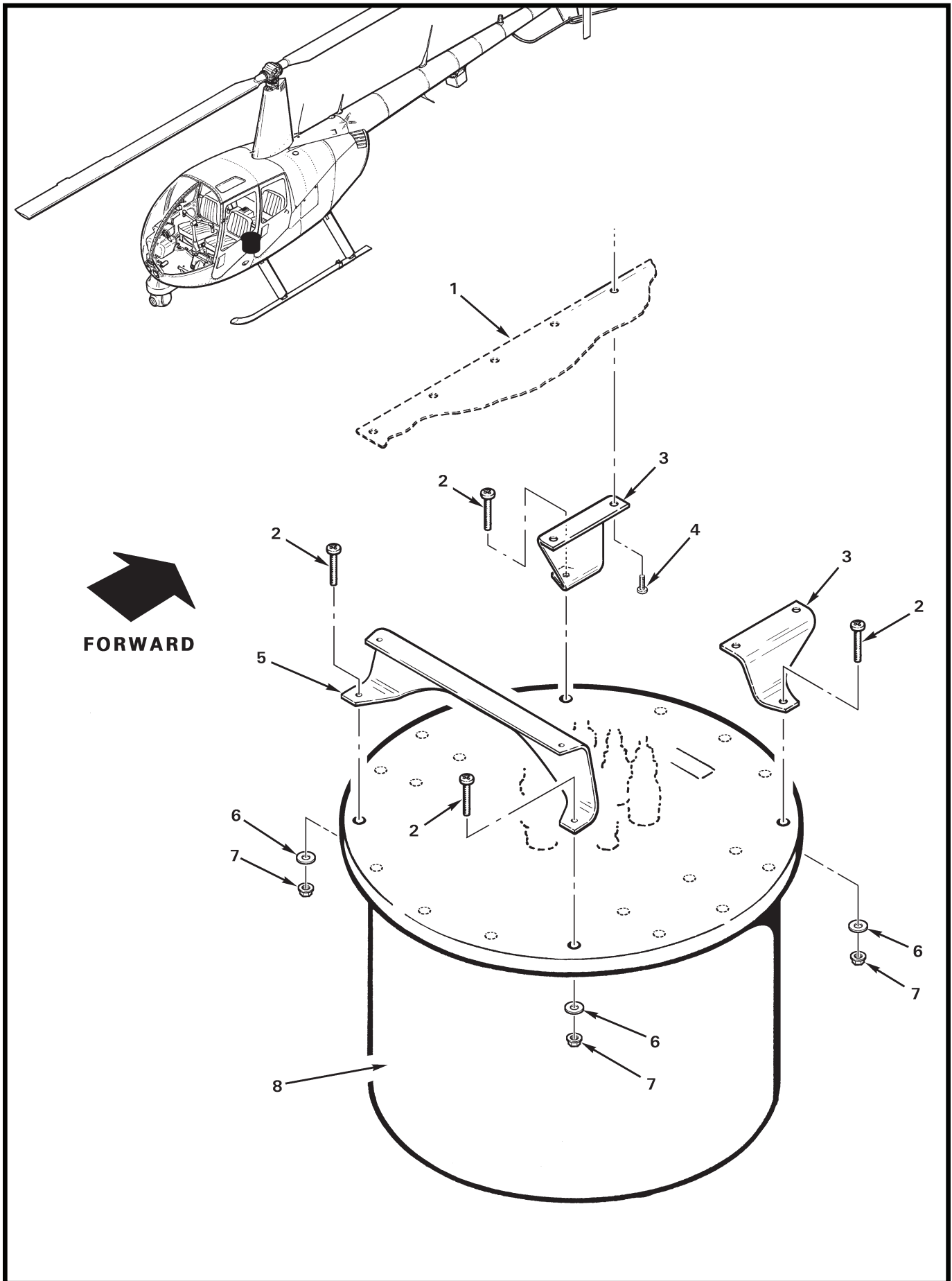

FIGURE AND INDEX NUMBER	PART NUMBER	DESCRIPTION	PARTS AVAIL	QTY PER ASSY
MICROWAVE ANTENNA INSTALLATION				
92-19-1	C794	Panel Assembly (Ref)		
2	MS27039C1-15	Screw	X	4
3	D586-3	Bracket (PA8, Auto-Pod-2 pod antenna)	X	2
	D586-5	Bracket (PA16)	X	2
4	MS27039C0807	Screw	X	6
5	D586-4	Bracket (PA8, Auto-Pod-2 pod antenna)	X	1
	D586-6	Bracket (PA16)	X	1
6	NAS1149F0316P	Washer	X	4
7	MS21042L3	Nut	X	4
8	PA8*	Antenna – Microwave (Ref, not shown)		
	PA16*	Antenna – Microwave (Ref, not shown)		
	Auto-Pod-2**	Antenna – Microwave (2 GHz; Ref, older ships)		

NOTES * Peak Antennas part no.
 ** Microwave Radio Communications part no.

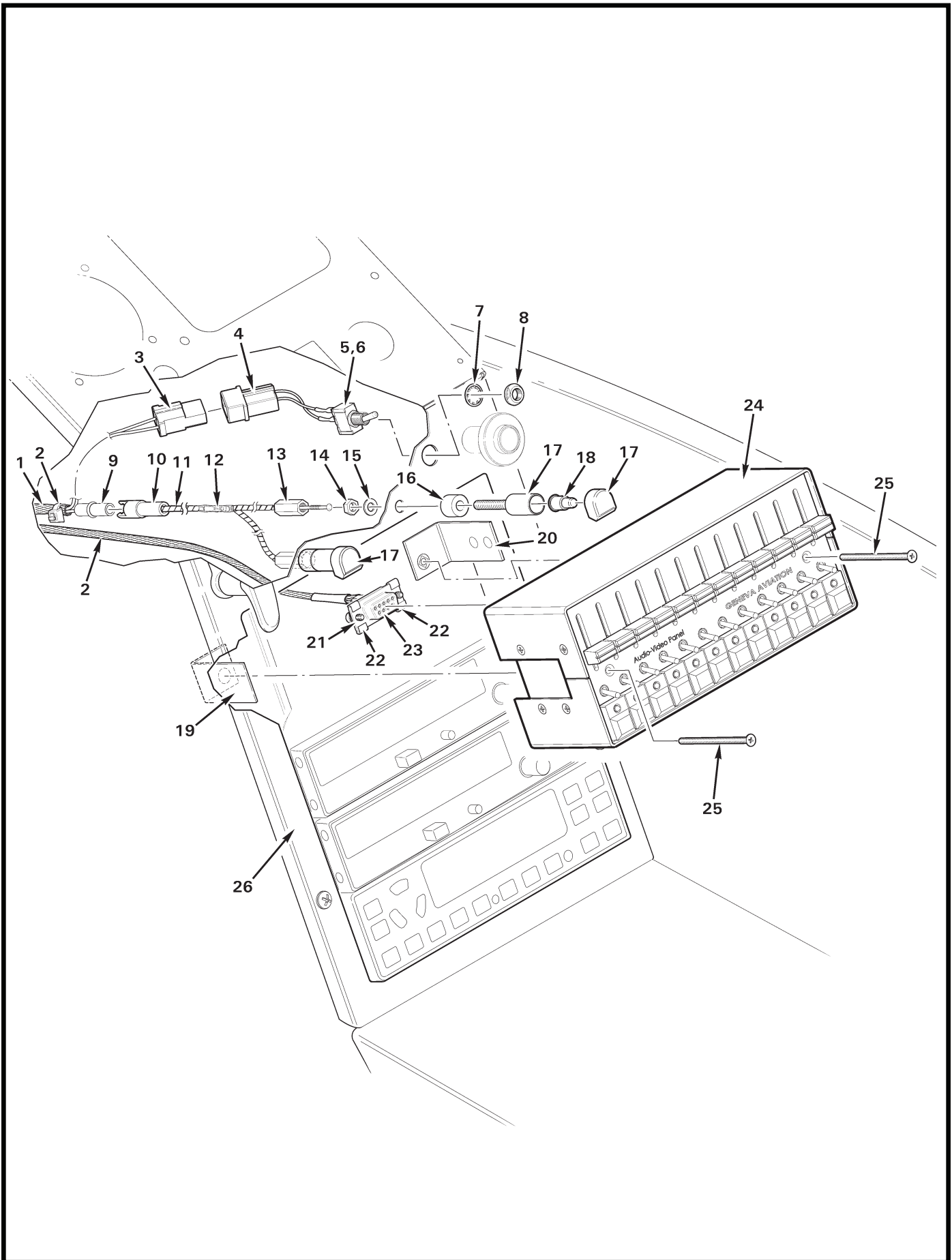

FIGURE AND INDEX NUMBER	PART NUMBER	DESCRIPTION	PARTS AVAIL	QTY PER ASSY
		GENEVA AUDIO - PILOT AUDIO PANEL		
92-21-1	B266-4	Sleeving	X	A/R
2	MS3367-5-9	Ty-Rap	X	A/R
3	B263-13	Housing	X	1
	B263-2	Socket	X	2
4	B263-12	Housing	X	1
	B263-1	Pin	X	2
5	B049-4	Switch Assembly (includes items 4 and 6)	X	1
6	B300-1	Switch Assembly (Incl items 7 and 8)	X	1
7	B227-3	Lockwasher	X	1
8	B227-4	Dress Nut	X	1
9	B263-11	Housing (Ref)	X	1
	B263-2	Socket	X	1
10	1-480350-0	Housing (Ref)		
11	B161-2	Spirap	X	A/R
12	B261-2	Wire Splice	X	1
13	—	Connector Nut (Ref)		
14	—	Nut	O	1
15	—	Lockwasher	O	1
16	A130-33	Spacer	X	2
17	B195-16	Post Light Assembly (Incl items 13 thru 16, and 18)	X	2
18	327	Lamp (28-volt)	X	1
19	D579-5	Bracket (LH, Ref)		
20	D579-6	Bracket (RH, Ref)		
21	B269-21	Backshell	X	1
22	B269-31	Male Screw Lock	X	2
23	B269-4	Receptacle	X	1
24	D579-8	Audio Panel (pilot; includes item 25)	X	1
25	—	Screw	O	1
26	D225-10	Face Assembly	X	1

NOTES

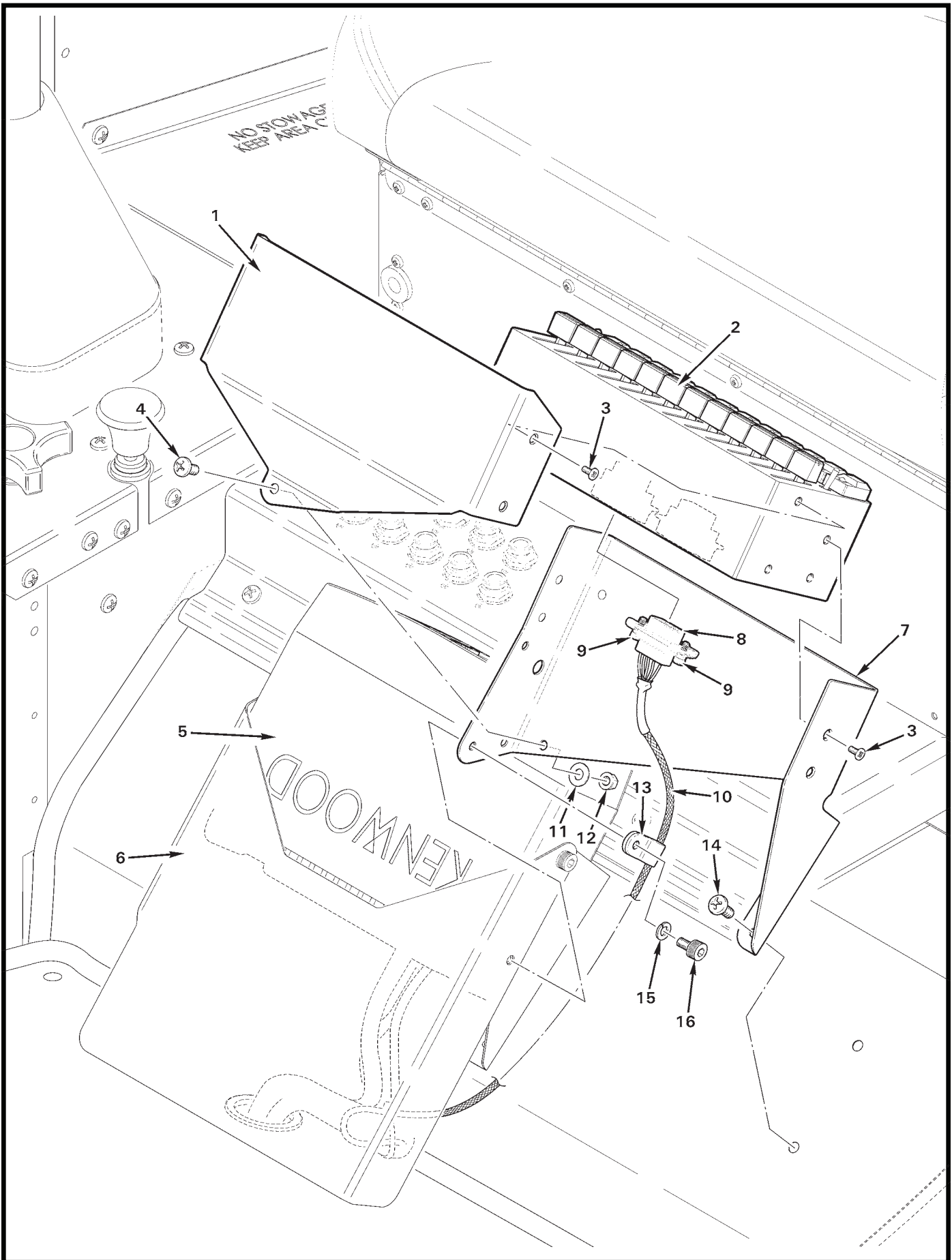

FIGURE AND INDEX NUMBER	PART NUMBER	DESCRIPTION	PARTS AVAIL	QTY PER ASSY
GENEVA AUDIO - CO-PILOT AUDIO PANEL				
92-23-1	D557-2	Cover	X	1
2	D579-7	Audio Panel (Incl item 3)	X	1
3	—	Screw	O	8
4	MS27039C0805	Screw	X	1
5	A824	FM Transceiver (Ref)		
6	D651-15	Guard (Ref)		
7	D592-1	Mount	X	1
8	B269-4	Receptacle	X	2
9	B269-31	Screw Lock (male)	X	2
10	B266-4	Sleeving	X	A/R
11	NAS1149FN816P	Washer	X	1
12	MS21042L08	Nut	X	1
13	7622	Clamp	X	1
14	MS27039C0806	Screw	X	2
15	—	Lockwasher (Ref, included with item 5)		
16	—	Screw (Ref, included with item 5)		

NOTES

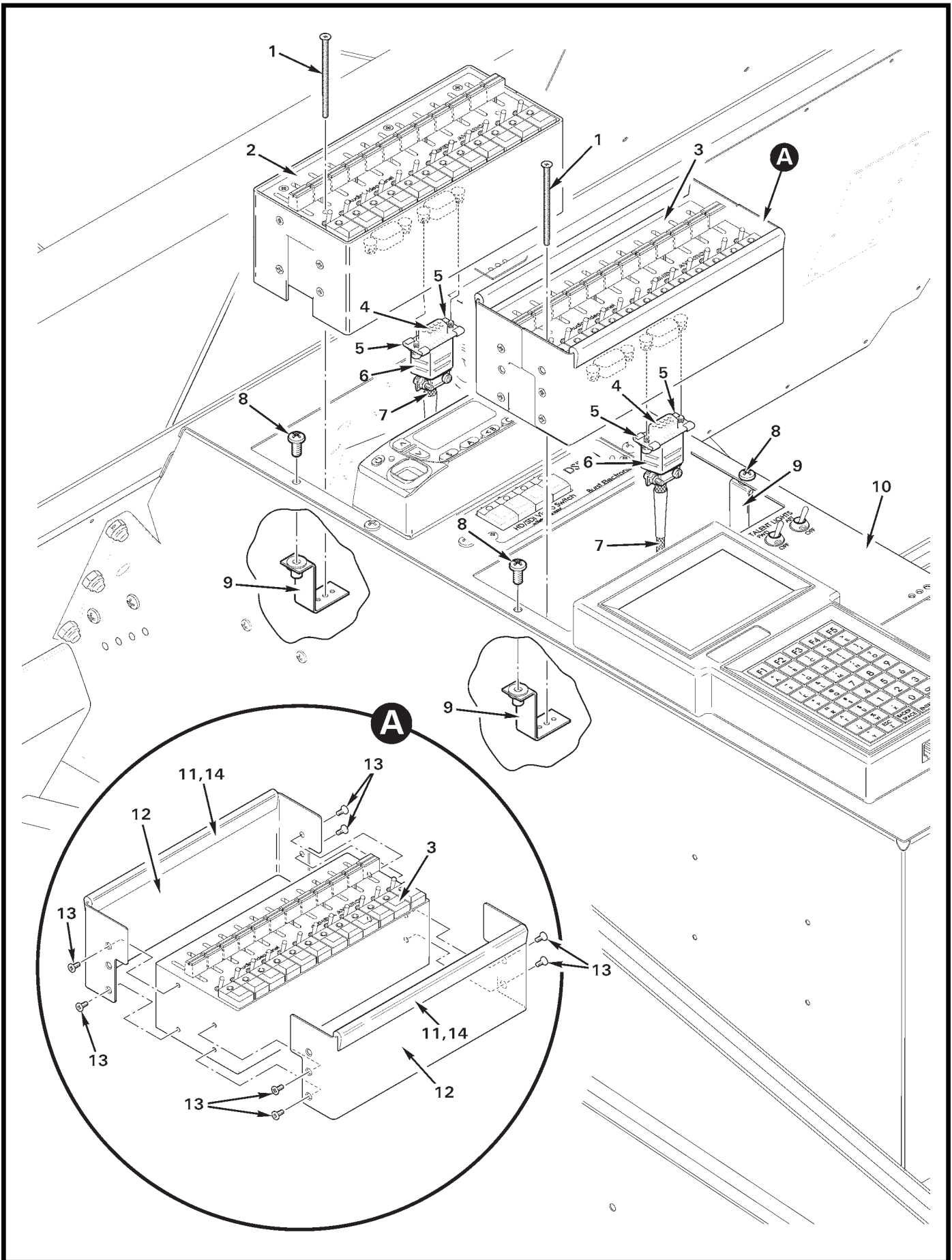

FIGURE AND INDEX NUMBER	PART NUMBER	DESCRIPTION	PARTS AVAIL	QTY PER ASSY
GENEVA AUDIO - AFT AUDIO PANELS				
92-25-1	—	Screw	O	2
2	D579-7	Audio Panel (photo, includes item 1)	X	1
3	D579-9	Audio Panel (microwave, includes items 1 and 13)	X	1
4	B269-4	Receptacle	X	1
5	B269-31	Screw Lock (male)	X	2
6	B269-21	Backshell	X	1
7	B266-4	Sleeving	X	A/R
8	MS27039C0806	Screw	X	4
9	D344-4	Angle Assembly	X	4
10	D383-5	Face (aft cabin console, Ref)		
11	4869A1	Molding (install using item 14)	X	A/R
12	D557-4	Cover Assembly (Incl item 11)	X	2
13	—	Screw	O	8
14	B270-4	Adhesive (or B270-13)	X	A/R

NOTES

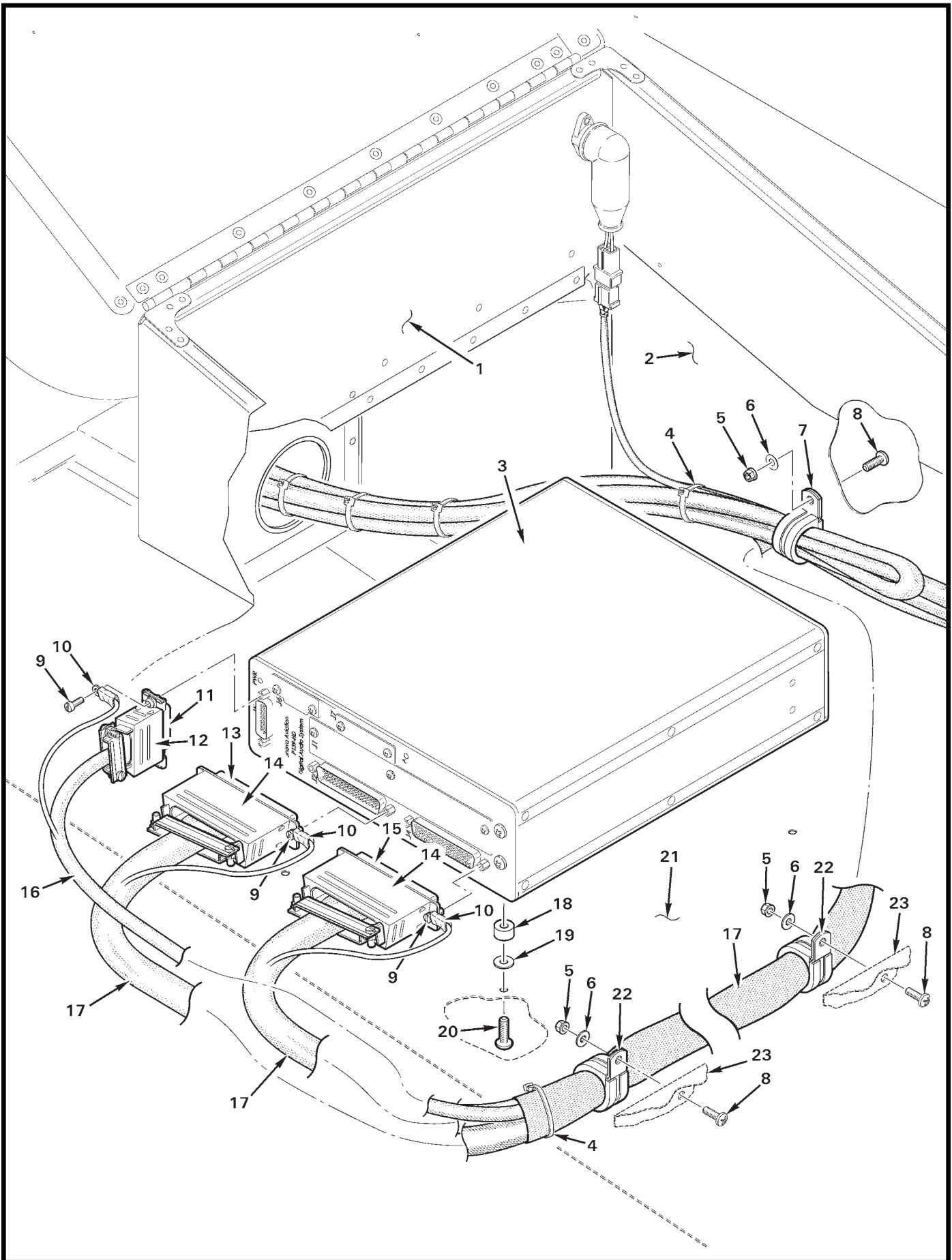

FIGURE AND INDEX NUMBER	PART NUMBER	DESCRIPTION	PARTS AVAIL	QTY PER ASSY
GENEVA AUDIO - DIGITAL ROUTER				
92-27-1	C297	Seat Support Assembly (LH Ref)		
2	C293-3	Keel Panel (LH, Ref)		
3	G13000	Router (P139HD Digital)	X	1
4	MS3367-5-0	Ty-Rap (black)	X	A/R
5	MS21042L08	Nut	X	3
6	NAS1149FN816P	Washer	X	3
7	MS21919WDG12	Clamp	X	1
8	MS27039C0806	Screw	X	3
9	—	Screw	O	2
10	B260-1	Terminal	X	3
11	B269-6	Receptacle	X	1
	B267-2*	Terminator	X	3
12	B269-22	Backshell	X	1
13	B269-20	Receptacle	X	1
	B267-3*	Terminator	X	12
14	B269-25	Backshell	X	2
15	B269-19	Plug	X	1
	B267-3*	Terminator	X	14
16	B266-4	Sleeving	X	A/R
17	B266-8	Sleeving	X	A/R
18	C130-50	Spacer	X	4
19	NAS1149F0332P	Washer	X	4
20	MS27039C1-10	Screw	X	4
21	C272	Chin (Ref)		
22	MS21919WDG14	Clamp	X	2
23	C390-5	Panel (LH, Ref)		

NOTES * Not shown.

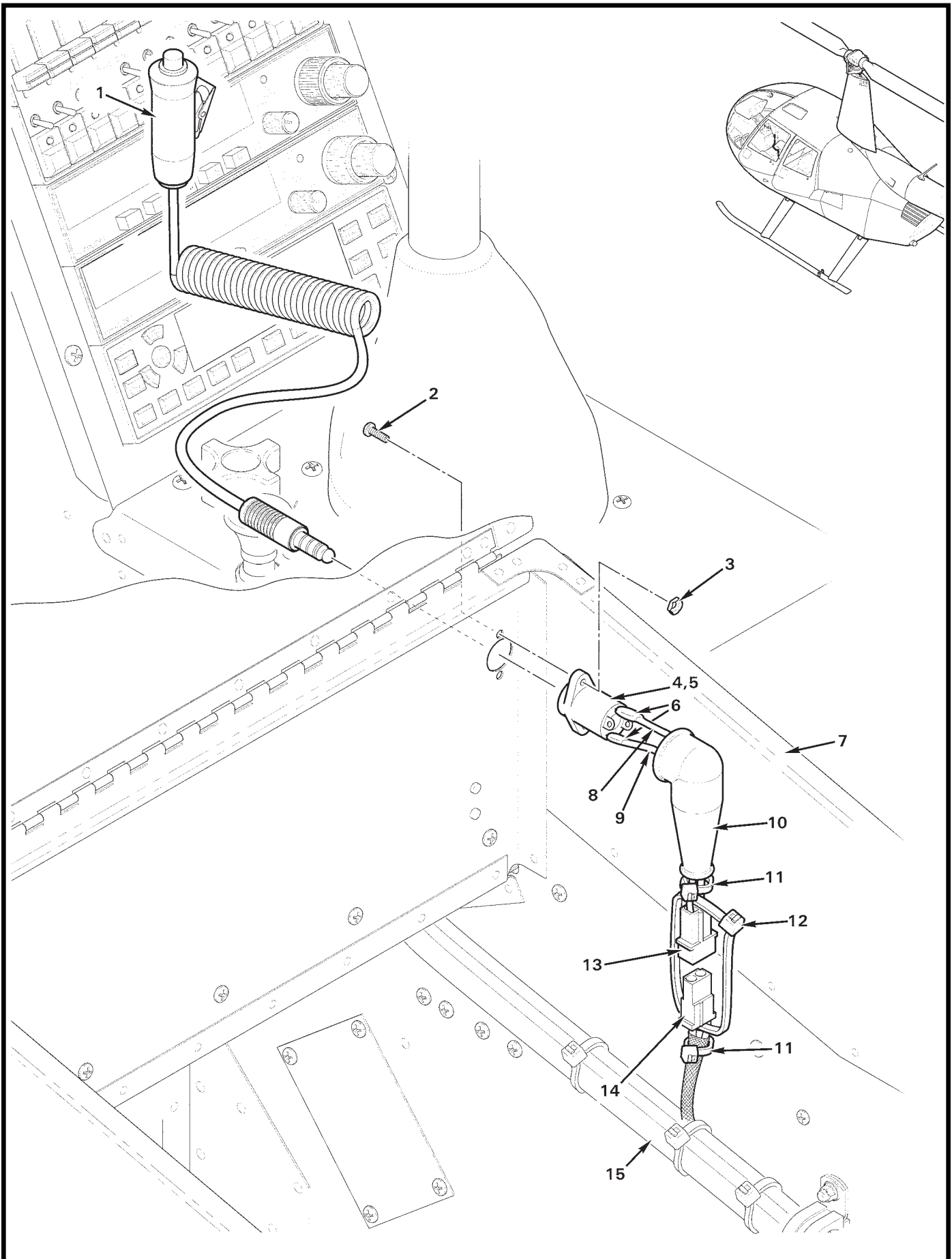

FIGURE AND INDEX NUMBER	PART NUMBER	DESCRIPTION	PARTS AVAIL	QTY PER ASSY
GENEVA AUDIO - TRANSMIT SWITCH				
92-29-1	B121-1	Transmit Switch Assembly	X	1
2	MS35206-215	Screw	X	2
3	B330-2	Palnut	X	2
4	C060-5	Transmit Switch Assembly (Includes items 1 thru 3, 5, 6, and 8 thru 14.)	X	1
5	TJ-120	Jack	X	1
6	B158-3	Heat Shrink	X	A/R
7	C297-5	Seat Support (Ref)		
8	- 162	Wire	X	1
9	- 163	Wire	X	1
10	MS25171-2S	Nipple	X	1
11	MS3367-4-9	Ty-Rap	X	A/R
12	MS3367-5-0	Ty-Rap	X	A/R
13	B263-12	Housing	X	1
	B263-1	Pin	X	2
14	B263-13	Housing	X	1
	B262-2	Socket	X	2
15	D059	Wire Harness (Ref)		

NOTES

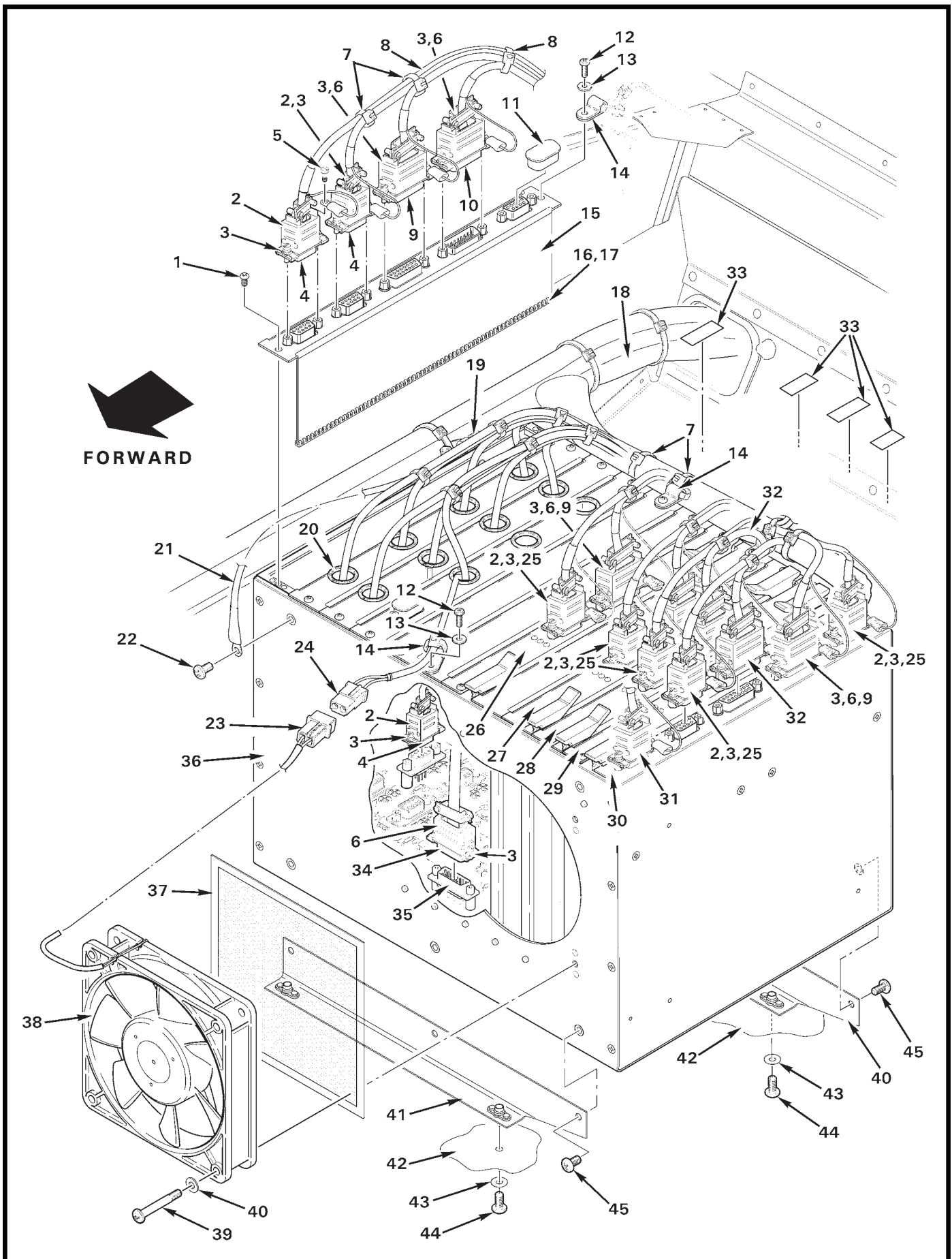

FIGURE AND INDEX NUMBER	PART NUMBER	DESCRIPTION	PARTS AVAIL	QTY PER ASSY
GENEVA AUDIO - BACKPLANE INSTALLATION				
92-31-1	—	Screw (Ref, Incl with item 36)	O	17
2	B269-21	Backshell	X	16
3	B269-31	Male Screw Lock (Incl item 5)	X	2
4	B269-3	Plug (9-pin)	X	11
5	—	Screw	O	2
6	B269-22	Backshell	X	5
7	MS3367-5-9	Ty-Rap	X	A/R
8	B161-4	Spirap	X	A/R
9	B269-8	Receptacle	X	4
10	B269-7	Plug (15-pin)	X	1
11	DE-60-20	Cover	X	A/R
12	MS35206-215	Screw	X	5
13	NAS1149FN432P	Washer	X	5
14	7622	Clamp	X	5
15	G11430	Audio Expander Board (Incl items 16 and 17)	X	1
16	MS21266-1N	Grommet (install using item 17)	X	A/R
17	B270-8	Adhesive (or B270-14)	X	A/R
18	D059-1	Harness Assembly (Ref)		
19	MS21919WDG2	Clamp (Ref, see Figure 90-35)		
20	—	Grommet	O	11
21	—	Wire (no. 1140, ground; Ref)		
22	MS27039C0805	Screw	X	1
23	B263-12	Housing	X	1
	B263-1	Pin	X	2
24	B263-13	Housing	X	1
	B263-2	Socket	X	2
25	B269-4	Receptacle (9-socket)	X	5
26	G11428	Microwave Audio Control Board	X	1
27	G11428	Photo Audio Control Board	X	1
28	G11428	Co-pilot Audio Control Board	X	1
29	G11428	Pilot Audio Control Board	X	1

NOTES

Continues

FIGURE AND INDEX NUMBER	PART NUMBER	DESCRIPTION	PARTS AVAIL	QTY PER ASSY
GENEVA AUDIO - BACKPLANE INSTALLATION (Cont'd)				
92-31-30	G11430	Com Direct Board	X	1
31	D393-4	Harness Assembly (item 30 "J1" connector-to-backplane attenuator "J1")	X	1
32	D393-2	Harness Assembly (item 30 "J3" connector-to-item 29 "J2" connector)	X	1
33	C654-35	Decal ("M/WAVE, PHOTO, COPILOT, and PILOT"; one label) . .	X	1
34	B269-6	Receptacle (15-socket; to backplane power connector [item 35])	X	1
35	—	Backplane "Power" Connector (Ref)		
36	D579-2	Backplane (STD MIC, includes items 1 and 45; Ref)		
	D579-3	Backplane (HOT MIC, includes items 1 and 45; Ref)		
37	D578-1	Screen Assembly	X	1
38	D580-1	Fan Assembly (Incl item 23)	X	1
39	MS27039C0821	Screw	X	4
40	NAS1149FN832P	Washer	X	4
41	D429-4	Bracket Assembly	X	2
42	F272	Chin (Ref)		
43	NAS1149FN816P	Washer	X	4
44	MS27039C0806	Screw	X	4
45	—	Screw (included with item 36)	O	4

NOTES

Intentionally Blank

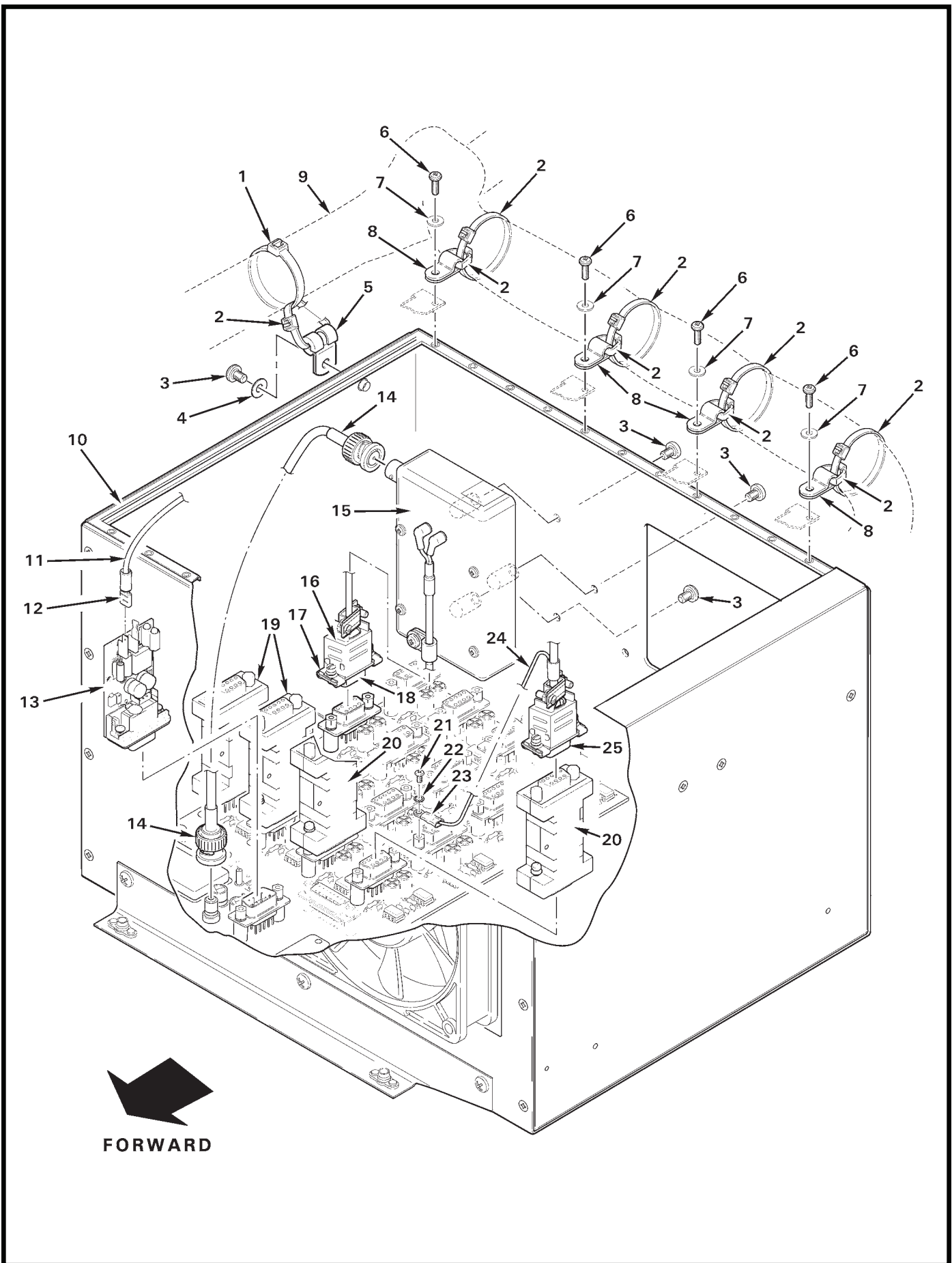

FIGURE AND INDEX NUMBER	PART NUMBER	DESCRIPTION	PARTS AVAIL	QTY PER ASSY
GENEVA AUDIO – BACKPLANE COMPONENTS				
92-35-1	MS3367-7-0	Ty-Rap	X	1
2	MS3367-5-0	Ty-Rap	X	9
3	MS35206-241	Screw	X	4
4	NAS1149FN816P	Washer	X	1
5	MS21919WDG2	Clamp	X	1
6	MS35206-215	Screw	X	4
7	NAS1149FN432P	Washer	X	4
8	7622	Clamp	X	4
9	D059	Harness Assembly (Ref)		
10	D579	Backplane (Ref, see also Figure 90-31)		
11	—	Wire (no. 1152; Ref)		
12	B262-2	Terminal	X	1
13	G12266	Module (GNET, Ref)		
14	D431-1315	Cable Assembly	X	1
15	D654-3	Tone Generator Assembly (Incl items 16 thru 18)	X	1
16	B269-21	Backshell	X	1
17	B269-31	Male Screw Lock	X	1
18	B269-3	Plug (9-pin)	X	1
19	G11432-2	Attenuator (at backplane connectors "J3" and "J2")	X	2
20	G11432-1	Attenuator (at backplane connectors "J1" and "J2")	X	2
21	MS35206-211	Screw	X	8
22	MS35333-36	Washer	X	8
23	B260-1	Terminal	X	20
24	—	Wire (ground, Ref)		
25	B269-3	Plug (9-pin, Ref)		

NOTES

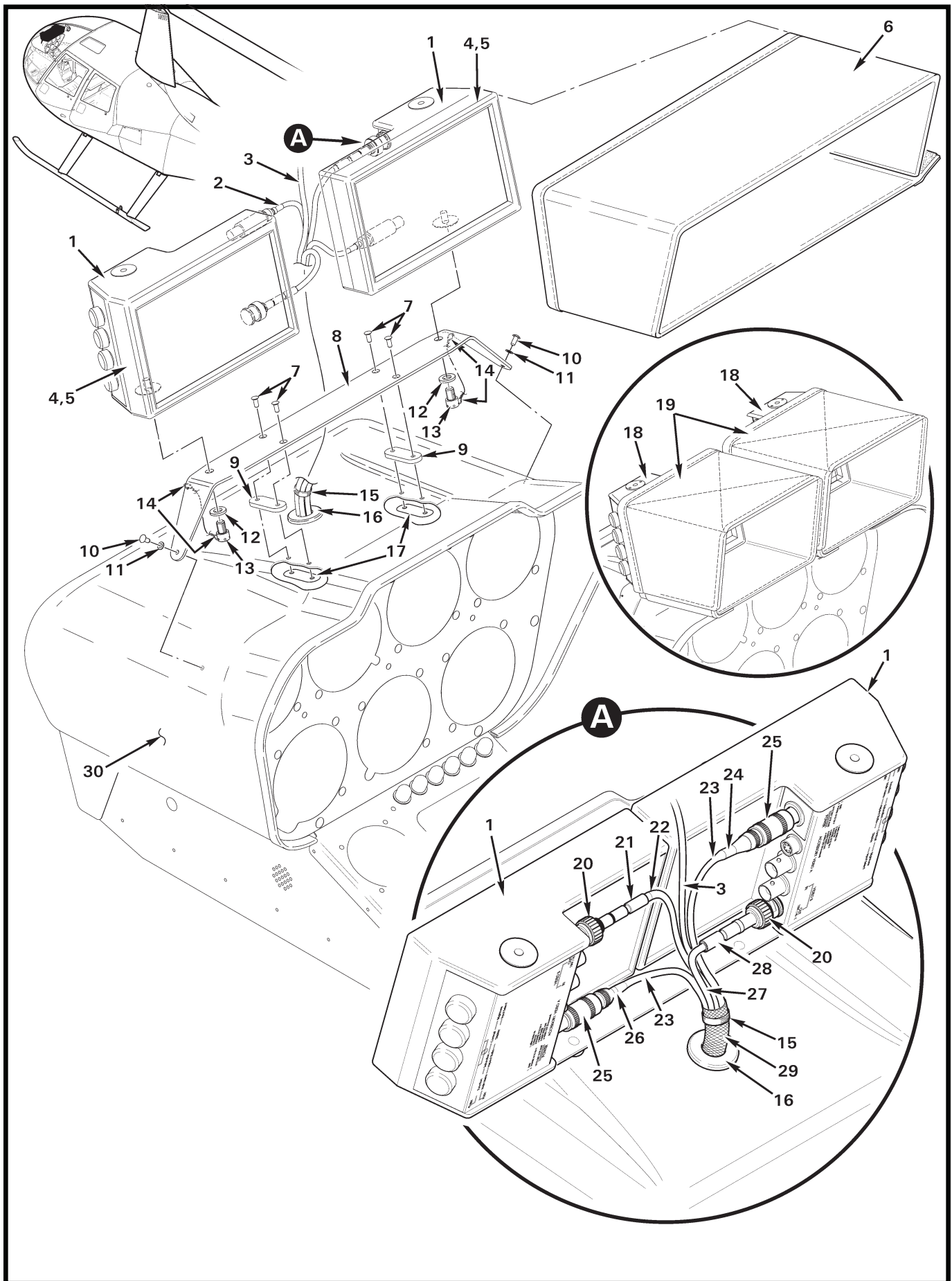

FIGURE AND INDEX NUMBER	PART NUMBER	DESCRIPTION	PARTS AVAIL	QTY PER ASSY
FORWARD MONITORS INSTALLATION				
92-37-1	D656-4	Monitor (NTSC & PAL; 6.5 in. Rainbow II)	X	2
2	D392-6	Harness Assembly (Incl items 18 thru 27)	X	1
3	—	Cable Assembly (Ref; windshield bow camera)		
4	B175-1	Hook Tape (install using item 5)	X	A/R
5	B270-8qt	Adhesive	X	A/R
6	HWDUALR	Visor	X	1
7	MS20426AD4	Rivet	X	4
8	D344-8	Bar (7-hole console)	X	1
	D344-14	Bar (9-hole console; not shown)	X	1
9	D344-9	Spacer	X	2
10	MS20470AD4	Rivet	X	2
11	NAS620-5	Washer	X	2
12	NAS1149F0463P	Washer	X	2
13	NAS1352-4H6P	Screw	X	2
14	MS20995C32	0.032 in.-dia Safety Wire	X	A/R
15	B268-3	Lacing Tape	X	A/R
16	MS35489-16	Grommet	X	1
17	A185-3	Plate	X	2
18	D656-3	Monitor (NTSC & PAL; 5 in. Rainbow II)	X	1
19	9HOODSD	Visor (earlier ships)	X	2
20	2065-11-9	Plug	X	2
21	B158-3	Heat Shrink (labeled "779")	X	A/R
22	D392-779	Wire (Ref)		
23	B266-4	Sleeving	X	A/R
24	D392-979	Wire (Ref)		
	D392-981	Wire (Ref)		
25	FFAIS302CLAC57	Connector	X	2
	B158-1	Heat Shrink (not shown)	X	A/R
26	D392-978	Wire (Ref)		
	D392-980	Wire (Ref)		
27	D392-780	Wire (Ref)		

NOTES

Continues

FIGURE AND INDEX NUMBER	PART NUMBER	DESCRIPTION	PARTS AVAIL	QTY PER ASSY
FORWARD MONITORS INSTALLATION (Cont'd)				
92-37-28	B158-3	Heat Shrink (labeled "780")	X	A/R
29	B266-8	Sleeving	X	A/R
30	B050	Console Assembly (Ref; 7 or 9 hole)		
NOTES				

CHAPTER 94

CADET VERSION

<i>Figure</i>	<i>Title</i>	<i>Page</i>
94-1	Cadet Version	94.0
94-3	Cadet Aft Cabin Components	94.2

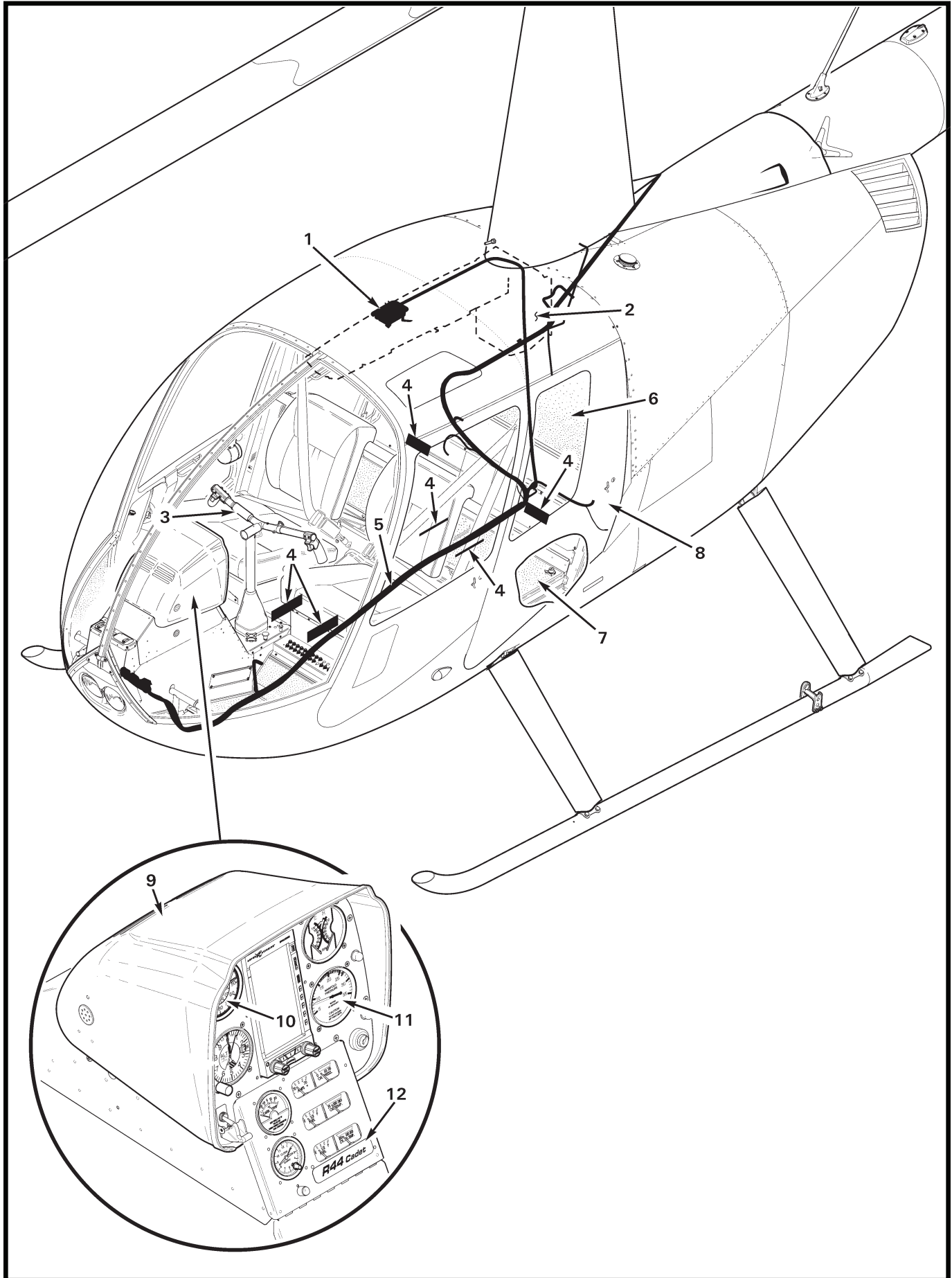

FIGURE AND INDEX NUMBER	PART NUMBER	DESCRIPTION	PARTS AVAIL	QTY PER ASSY
R44 CADET VERSION				
94-1-1	C060	Audio System (Ref; no aft audio jacks)		
2	—	Air Conditioning Installation (Ref, optional. See Figures 21-5, 21-11, 21-15, 21-27, and 21-29)		
3	C654	Decal – Limitations (Ref; see Figure 67-15B)		
4	G682	Decals (Ref, see Figures 11-1, and 94-3)		
5	C859	Wire Harness (Ref)		
6	C003	Interior Furnishings (Ref; see Figures 25-29, and 25-33)		
7	—	Aft Cabin Installation (Ref, see Figures 25-5 and 94-3)		
8	C026	Door Assembly – Aft (Ref; see Figure 52-13)		
9	G050	Console Assembly (Ref; see Figures 95-61, 95-65, and 95-69)		
10	C599	Airspeed Indicator (Ref; see Figures 95-61 and 95-65)		
11	A600	Manifold Pressure Gage (Ref; see Figure 95-61 and 95-65)		
12	G054	Plate (Ref; see Figure 95-69)		
NOTES				

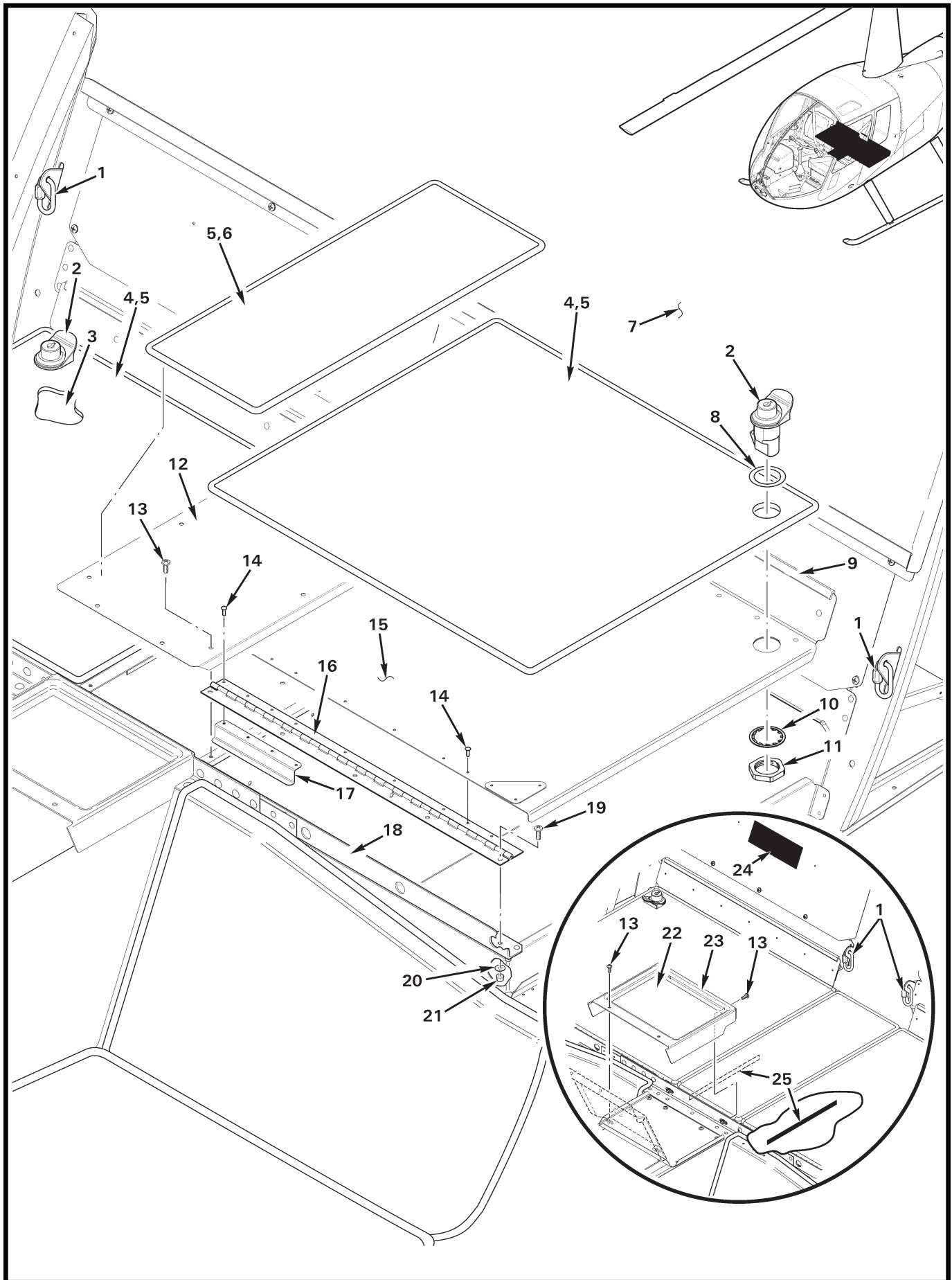

FIGURE AND INDEX NUMBER	PART NUMBER	DESCRIPTION	PARTS AVAIL	QTY PER ASSY
CADET AFT CABIN COMPONENTS				
94-3-1	8947T24	Link	X	4
	3712T31	Link (earlier R44s)	O	4
2	93-313	Latch (Incl items 10 and 11)	X	2
3	C703-2	Cover Assembly (RH; includes items 14, 16, and 17)	X	1
4	C469-54*	Carpet Assembly (RH and LH; bond using item 5)	X	2
5	B270-8QT	Adhesive	X	A/R
6	C469-55*	Carpet Assembly (center; bond using item 5)	X	1
7	C003-24	Insulation (Ref, see Figure 25-33)		
8	90089A420	Washer – Shim	X	A/R
9	A226-15	Trim	X	A/R
10	—	Lockwasher	O	1
11	—	Nut	O	1
12	C474-4	Cover	X	1
13	MS27039C0806	Screw	X	A/R
14	MS20470AD3	Rivet	X	32
15	C703-1	Cover Assembly (LH; includes items 14, 16, and 17)	X	1
16	C704-10	Hinge	X	1
17	C704-8	Stiffener	X	1
18	C704-11	Angle Assembly (Ref; see also Figure 25-5)		
19	MS27039C0807	Screw	X	20
20	NAS1149FN816P	Washer	X	20
21	MS21042L08	Nut	X	20
22	C464-3	Pad	X	1
23	C464-1	Tray (Incl item 22)	X	1
24	G682-34	Decal – “DO NOT OCCUPY...” (RH and LH; aft loading instructions)	X	2
25	G682-35	Decal – “COMPARTMENT LOAD LIMIT...”	X	2

NOTES * Available in dark charcoal only.

Intentionally Blank

CHAPTER 95
INSTRUMENT SYSTEM

<i>Figure</i>	<i>Title</i>	<i>Page</i>
95-1	Garmin G500H Console – Instruments	95.0
95-5	Garmin G500H Console – GDU 620 Display	95.4
95-7	Garmin G500H Console – Pitot/Static Tubes	95.6
95-9	Garmin G500H Console – Components	95.8
95-13	Aspen PFD Installation	95.12
95-15	Aspen PFD and MFD Installation	95.14
95-17	Aspen PFD Installation – Pitot/Static Lines	95.16
95-19	Aspen PFD Installation – Pitot/Static Lines	95.18
95-21	Aspen PFD and MFD Installation – Pitot/Static Lines	95.20
95-23	Seven-Instrument Console Assembly	95.22
95-27	Seven-Instrument Console Assembly	95.26
95-33	Nine-Instrument Console Assembly	95.32
95-35	Ten-Instrument Console Assembly (IFR Trainer)	95.34
95-41	Ten-Instrument Console Assembly (IFR Trainer)	95.40
95-45	Compass Installation	95.44
95-47	Digital Clock Installation	95.46
95-49	Pitot/Static Lines Installation	95.48
95-53	Heated Pitot Installation	95.52
95-55	Radar Altimeter Indicator Installation	95.54
95-57	Radar Altimeter Indicator Installation	95.56
95-59	Radar Altimeter Installation	95.58
95-61	Six-Instrument Console Assembly	95.60
95-65	Eight-Instrument Console Assembly	95.64
95-69	Instrument Console Assembly – Lower Panel (R44)	95.68
95-73	Instrument Console Assembly – Lower Panel (R44 II)	95.72

CHAPTER 95

INSTRUMENT SYSTEM (Cont'd)

<i>Figure</i>	<i>Title</i>	<i>Page</i>
95-77	Six-Instrument Console Assembly – Components	95.76
95-81	Eight-Instrument Console Assembly – Components (R44)	95.80
95-83	Eight-Instrument Console Assembly – Components (R44 II)	95.82

Intentionally Blank

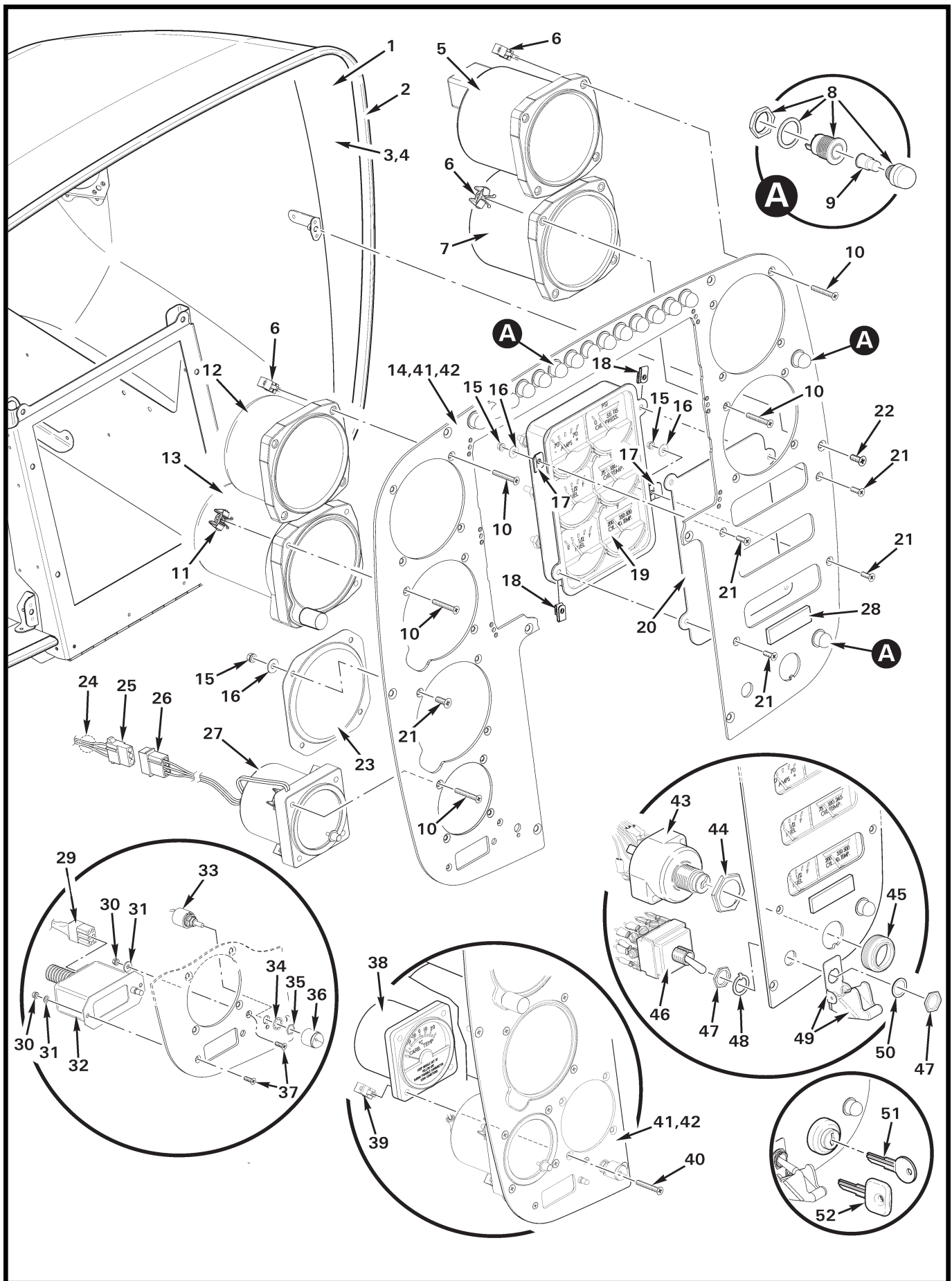

FIGURE AND INDEX NUMBER	PART NUMBER	DESCRIPTION	PARTS AVAIL	QTY PER ASSY
GARMIN G500H CONSOLE – INSTRUMENTS				
95-1-1	G061	Shell Assembly (Ref)		
2	A226-11	Trim	X	A/R
3	G061-4	Liner (install using item 4)	X	1
4	B270-8qt	Adhesive	X	A/R
5	C792-4	Dual Tachometer	X	1
6	MS33737-15C	Nut	X	12
7	A600-4*	Manifold Pressure Gage	X	1
	A600-6**	Manifold Pressure Gage	X	1
8	B198-1	Light – Caution (Amber; clutch actuator, main rotor temperature, main rotor chip, carbon monoxide, starter, tail rotor chip, low fuel, low rotor rpm, alternator, fuel filter***, aux fuel pump***, gov off, throttle, and brake. Order item 9 when replacing lamp.)	X	A/R
	B198-2	Light – Warning (Red; engine fire, oil pressure. Order item 9 when replacing lamp.)	X	2
9	B196-21	Lamp (28-volt)	X	16
	B196-1	Lamp (14-volt)	X	14
10	MS24693-S32	Screw	X	19
11	MS33737-13C	Nut	X	3
12	C599-1	Airspeed Indicator (130 knot V _{NE})	X	1
13	A613-1	Altimeter	X	1
14	G065-13	Face Assembly (R44 II, standard; not shown; GDU 620)	X	1
	G065-14	Face Assembly (R44 II, optional VSI installed; GDU 620)	X	1
	G065-16	Face Assembly (R44 II, standard; not shown; GDU 1060)	X	1
	G065-19	Face Assembly (R44 II, optional VSI installed; GDU 1060)	X	1
15	MS21042L06	Nut	X	6
16	NAS1149FN616P	Washer	X	6
17	B181-8	Retainer	X	2
18	B162-1	Clipnut	X	2
19	B144-4	Instrument Cluster (Incl items 18 and 20)	X	1
20	0003-00434	Window Crystal (clear plastic)	X	1
	0015-00723	Gasket (not shown)	X	1
21	MS24693-S27	Screw	X	A/R
22	MS24694-S4	Screw	X	8
23	B190-6	Cover	X	A/R

NOTES * Ship S/N 0001 thru 9999.
 ** Ship S/N 10001 and subsequent.
 *** If installed.

Continues

FIGURE AND INDEX NUMBER	PART NUMBER	DESCRIPTION	PARTS AVAIL	QTY PER ASSY
GARMIN G500H CONSOLE – INSTRUMENTS (Cont'd)				
95-1-24	G717-133	Wire (Ref)		
	G717-134	Wire (Ref)		
	G717-137	Wire (Ref)		
25	B263-15	Housing	X	1
	B263-2	Socket	X	3
26	B263-14	Housing	X	1
	B263-1	Pin	X	3
27	A072-13	Clock Assembly (Incl item 26)	X	1
28	A743-1	Call Letters Plate (please specify call letters)	X	1
	A701-7	Tape	X	A/R
29	B341-4	Probe Assembly (OAT)	X	1
30	MS21042L04	Nut	X	2
31	NAS1149FN432P	Washer	X	2
32	B341-1	Gage (OAT)	X	1
33	B398-1	Potentiometer (Ref)		
34	—	Lockwasher	O	1
35	—	Nut	O	1
36	MS91528-OC1B	Knob	X	1
37	MS24693-S4	Screw (install using B270-20 adhesive)	X	2
38	C604-8	Carb Air Temp Gage (Incl item 37)	X	1
39	MS33737-12C	Nut	X	4
40	MS24693-S32	Screw	X	4
41	G065-12	Face Assembly (R44, optional VSI installed; GDU 620)	X	1
	G065-11	Face Assembly (R44, standard; not shown, GDU 620)	X	1
42	G065-15	Face Assembly (R44, optional VSI installed; GDU 1060)	X	1
	G065-18	Face Assembly (R44, standard; not shown, GDU 1060)	X	1
43	A661-2	Switch – Ignition (Incl items 41, 42, and two keys)	X	1
44	—	Nut	O	1
45	—	Nut	O	1
46	MS25068-23	Switch – Clutch (Incl items 47, 48, and 50)	X	1
47	—	Nut	O	2
48	—	Keywasher	O	1
49	MS25224-1	Guard	X	1
50	—	Lockwasher	O	1

NOTES

Continues

FIGURE AND INDEX NUMBER	PART NUMBER	DESCRIPTION	PARTS AVAIL	QTY PER ASSY
GARMIN G500H CONSOLE – INSTRUMENTS (Cont'd)				
95-1-51	R8096	Key – Duplicate (Specify ship S/N and “PK” numbers when ordering.)	X	1
52	D768-2	Key (blank; black plastic-coated “R44” Logo)	X	1
NOTES				

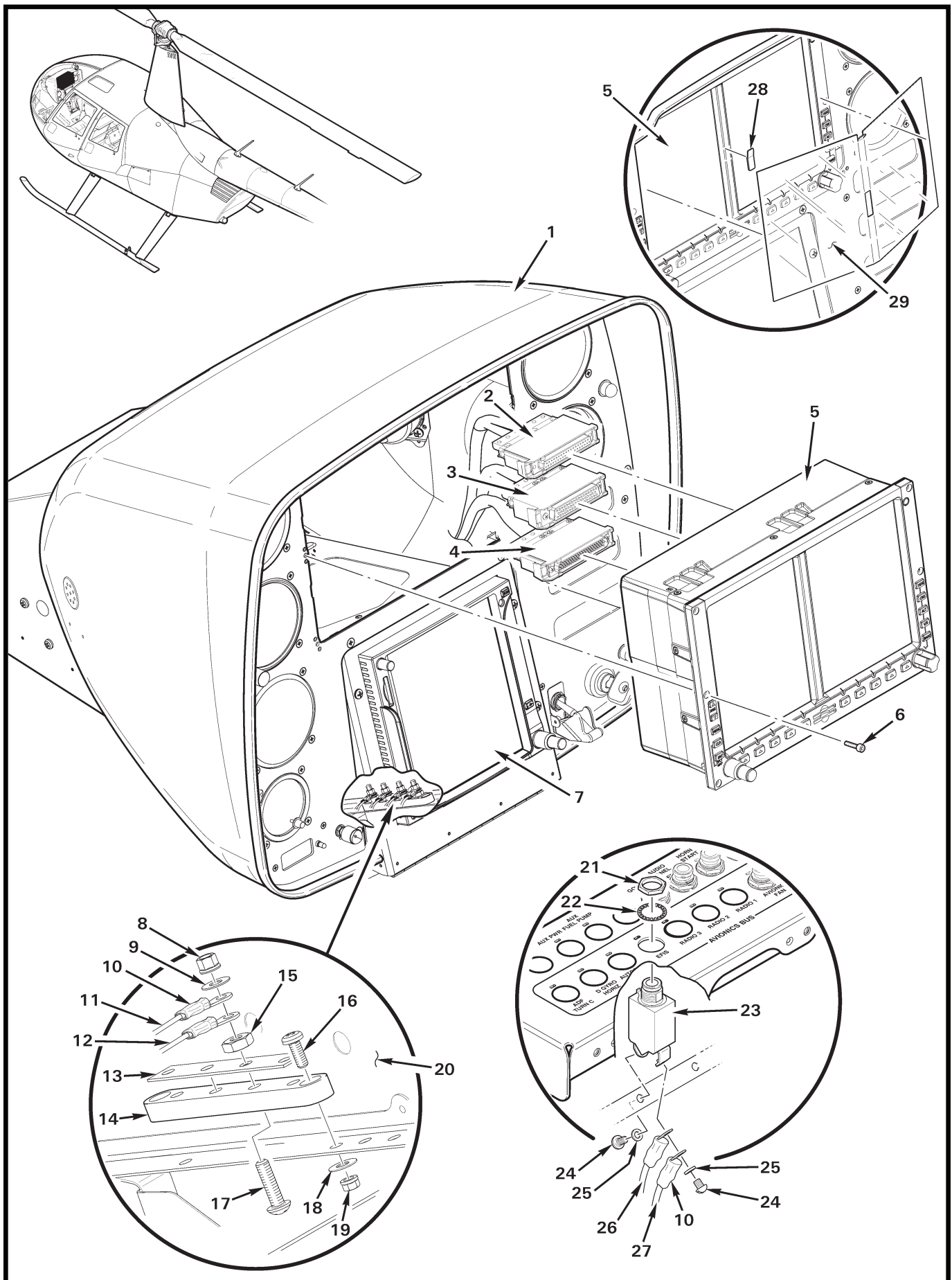

FIGURE AND INDEX NUMBER	PART NUMBER	DESCRIPTION	PARTS AVAIL	QTY PER ASSY
		GARMIN G500H CONSOLE – GDU 620 DISPLAY		
95-5-1	G060	Console Assembly (Ref)		
2	P6201	Connector (Ref)		
3	P6202	Connector (Ref)		
4	P6203	Connector (Ref)		
5	GDU 620*	Display (PFD and MFD; includes items 2 thru 4, and 6)	X	1
6	211-64307-14*	Screw (or NAS1352-06-10)	O	6
7	GTN 7XX*	GPS Navigator Display (Ref, or GTN 600-series display [not shown]. See Figure 97-1 for installation.)		
8	MS21042L08	Nut	X	A/R
9	NAS1149FN816P	Washer	X	A/R
10	B260-3	Terminal	X	A/R
11	F817-2564	Wire (Ref; ground, GDU 620 Display)		
12	F817-2589	Wire (Ref; ground, GSU 75 ADAHRS)		
13	A448-10	Bus Bar (4 holes)	X	1
14	C448-2	Block Assembly (Incl block and items 13, 15, and 17)	X	1
	C448-5	Block (4 holes)	X	1
15	B301-8	Nut	X	1
16	MS35206-228	Screw	X	2
17	B567-43	Screw	X	1
18	NAS1149FN616P	Washer	X	2
19	MS21042L06	Nut	X	2
20	F033-1	Lower Console Assembly (Ref)		
21	—	Nut	O	1
22	—	Washer	O	1
23	B297-5	Circuit Breaker (5 amp, includes items 21, 22, 24, and 25) . .	X	1
24	—	Screw	O	2
25	—	Washer	O	2
26	F817-2563	Wire (Ref; power, GDU 620 Display)		
27	F817-2695	Wire (Ref; ground, GSU 75 ADAHRS)		
28	D327-2	Retainer	X	1
29	D327-1	Shield – Glare (optional)	X	1

NOTES * Garmin part no.



FIGURE AND INDEX NUMBER	PART NUMBER	DESCRIPTION	PARTS AVAIL	QTY PER ASSY
GARMIN G500H CONSOLE – PITOT/STATIC TUBES				
95-7-1	G060	Console Assembly (Ref)		
2	A600-4	Manifold Pressure Gage (Ref)		
3	10-4-2-N-0	Fitting	X	3
4	A729-52	Tube	X	3
5	C599-1	Airspeed Indicator (Ref)		
6	A729-67	Tube	X	1
7	70-4-N-0	Tee	X	1
8	A729-70	Tube	X	A/R
9	A613-1	Altimeter (Ref)		
10	60-4-2-N-0	Tee	X	1
11	40-4-2-N-0	Elbow	X	1
12	A602	Rate-of-Climb Indicator (Ref)		
13	15-4-N-0	Union	X	3
14	A729-15	Tube (Ref)		
15	A729-6	Tube (Ref)		
16	A729-11	Tube (Ref)		
NOTES				

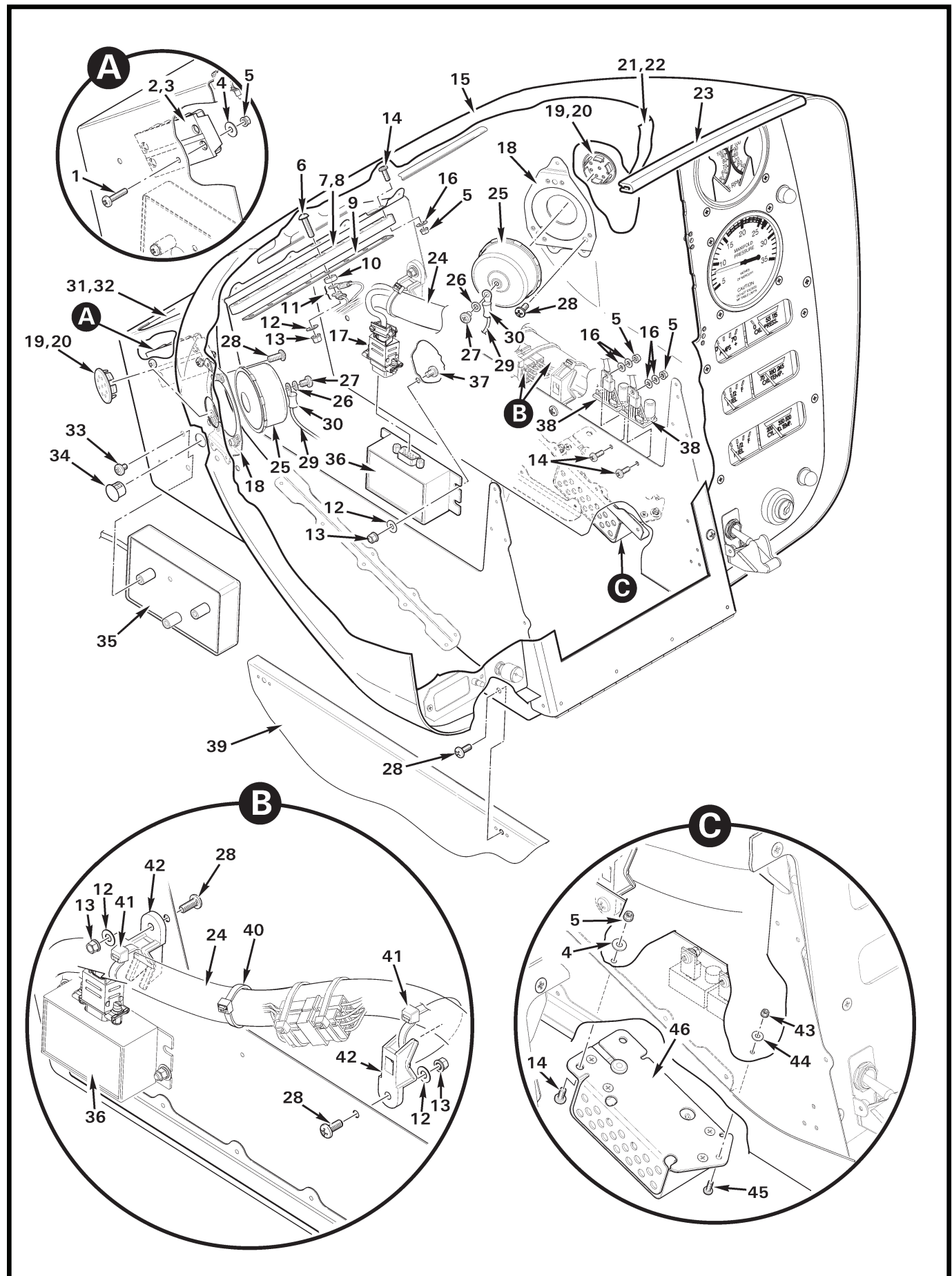

FIGURE AND INDEX NUMBER	PART NUMBER	DESCRIPTION	PARTS AVAIL	QTY PER ASSY
GARMIN G500H CONSOLE – COMPONENTS				
95-9-1	MS35206-231	Screw	X	2
2	38TB04F	Terminal Block (warning lights)	X	1
3	J601	Tab (not shown)	X	3
4	NAS1149FN616P	Washer	X	2
5	MS21042L06	Nut	X	4
6	B567-43	Screw (install using B270-9 adhesive)	X	8
7	C448-3	Block Assembly (Incl items 6, 8,9, and 10)	X	1
8	C448-6	Block (eight holes)	X	1
9	A448-14	Bus Bar (8 holes)	X	1
10	B301-8	Nut	X	8
11	B260-2	Terminal	X	18
12	NAS1149FN816P	Washer	X	9
13	MS21042L08	Nut	X	9
14	MS35206-228	Screw	X	6
15	G061-6	Shell Assembly (R44, Garmin GTN 6XX GPS installed. Includes items 18, 19 and 21 thru 23.)	X	1
	G061-9	Shell Assembly (R44 II, Garmin GTN 6XX GPS installed. Includes items 18, 19 and 21 thru 23.)	X	1
	G061-7	Shell Assembly (R44, [Dual] Garmin GTN 6XX GPS installed. Includes items 18, 19 and 21 thru 23.)	X	1
	G061-10	Shell Assembly (R44 II, [Dual] Garmin GTN 6XX GPS installed. Includes items 18, 19 and 21 thru 23.)		
	G061-8	Shell Assembly (R44, Garmin GTN 7XX GPS installed. Includes items 18, 19 and 21 thru 23.)	X	1
	G061-11	Shell Assembly (R44, Garmin GTN 7XX GPS installed. Includes items 18, 19 and 21 thru 23.)	X	1
16	NAS620-6	Washer	X	6
17	B269-4	Receptacle (Ref)		
	B269-21	Backshell (Ref)		
18	C479-1	Mount Assembly (Ref)		
19	9688K643	Hole Plug (install using item 20)	X	2
20	B270-18	Adhesive (or B270-8)	X	A/R
21	G061-4	Liner (vinyl, install using item 22)	X	1
22	B270-8qt	Adhesive	X	A/R
23	A226-11	Trim	X	A/R

NOTES

Continues

FIGURE AND INDEX NUMBER	PART NUMBER	DESCRIPTION	PARTS AVAIL	QTY PER ASSY
GARMIN G500H CONSOLE – COMPONENTS (Cont'd)				
95-9-24	D717-015	Wire Harness Assembly (R44, Ref; includes items 11, 17, 38 and 40)		
	G717-016	Wire Harness Assembly (R44 II, Ref; includes items 11, 17, 38 and 40)		
25	B320-3	Horn Assembly (includes items 26 thru 30, and 1-pin connector)	X	2
26	B332-42	Lockwasher	X	1
27	MS35206-241	Screw	X	1
28	MS27039C0806	Screw	X	11
29	B320-79	Wire (Ref)		
30	B260-3	Terminal	X	2
31	A226-3	Seal (install using item 27)	X	A/R
32	B270-13	Sealant	X	A/R
33	MS35206-241	Screw	X	6
34	2633	Hole Plug	X	1
35	A569-11	Low RPM Warning Unit (includes connector)	X	1
36	046L0210	Dimmer Assembly (includes connector)	X	1
37	MS27039C0805	Screw	X	2
38	D359-1	Regulator Assembly	X	2
39	C033	Lower Console Assembly (Ref)		
40	MS3367-5-0	Ty-Rap	X	A/R
41	MS3367-7-9	Ty-Rap	X	2
42	D268-2	Support	X	2
43	MS21042L04	Nut	X	1
44	NAS1149FN416P	Washer	X	1
45	MS35206-214	Screw	X	1
46	C696-1	CO Detector Assembly (includes connector)	X	1

NOTES

Intentionally Blank

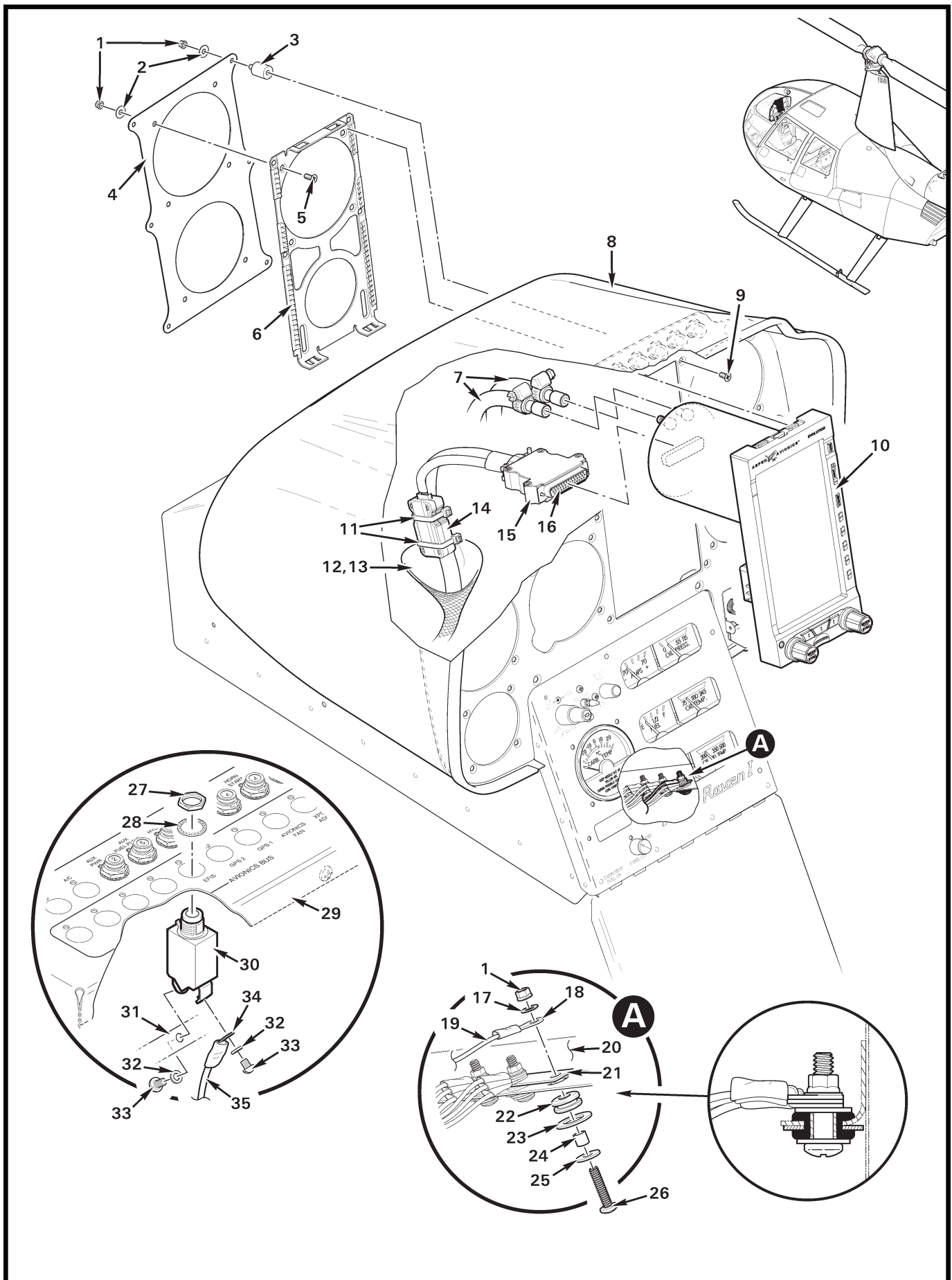

FIGURE AND INDEX NUMBER	PART NUMBER	DESCRIPTION	PARTS AVAIL	QTY PER ASSY
ASPEN PFD INSTALLATION				
95-13-1	MS21042L06	Nut	X	13
2	NAS1149FN616P	Washer	O	12
3	248-00002-001*	Isolator	X	6
4	C801-1	Panel	X	1
5	MS24693-S26	Screw	X	6
6	403-0003-001*	Bracket	O	1
7	A729-48	Tube (Ref, see Figure 95-69)		
8	G050	Console (Ref)		
9	MS24693-S24	Screw	X	6
10	EFD1000H*	PFD Display	O	1
11	MS3367-4-9	Ty-Rap	X	2
12	B247-607	Braid	X	A/R
13	7861K46	Heat Shrink	X	A/R
14	920-00004-117*	Module	O	1
15	116-00022-002*	Connector	O	1
16	116-00026-006*	Backshell	O	1
17	NAS620-6L	Washer	X	1
18	B260-3	Terminal	X	1
19	-2557	Wire (Ref)		
20	C033	Console Assembly – Lower (Ref)		
21	A448-15	Bus Bar (3-hole)	X	1
22	MS35489-4	Grommet	X	1
23	NAS1149F0532P	Washer (install in grommet groove; see detail showing parts assembled)	X	1
24	C130-59	Spacer (install in grommet bore; see detail showing parts assembled)	X	1
25	NAS1149FN632P	Washer	X	1
26	B567-28	Screw	X	1
27	—	Nut	O	1
28	—	Lockwasher	O	1
29	C490-12	Circuit Breaker Panel (Ref)		
30	B297-7	Circuit Breaker (7.5 amp; includes items 27, 28, 32, & 33) . . .	X	1
31	A448	Bus Bar (Ref)		
32	—	Washer	O	2
33	—	Screw	O	2
34	B260-2	Terminal	X	1
35	-2555	Wire (Ref)		

NOTES * Aspen Avionics part no.

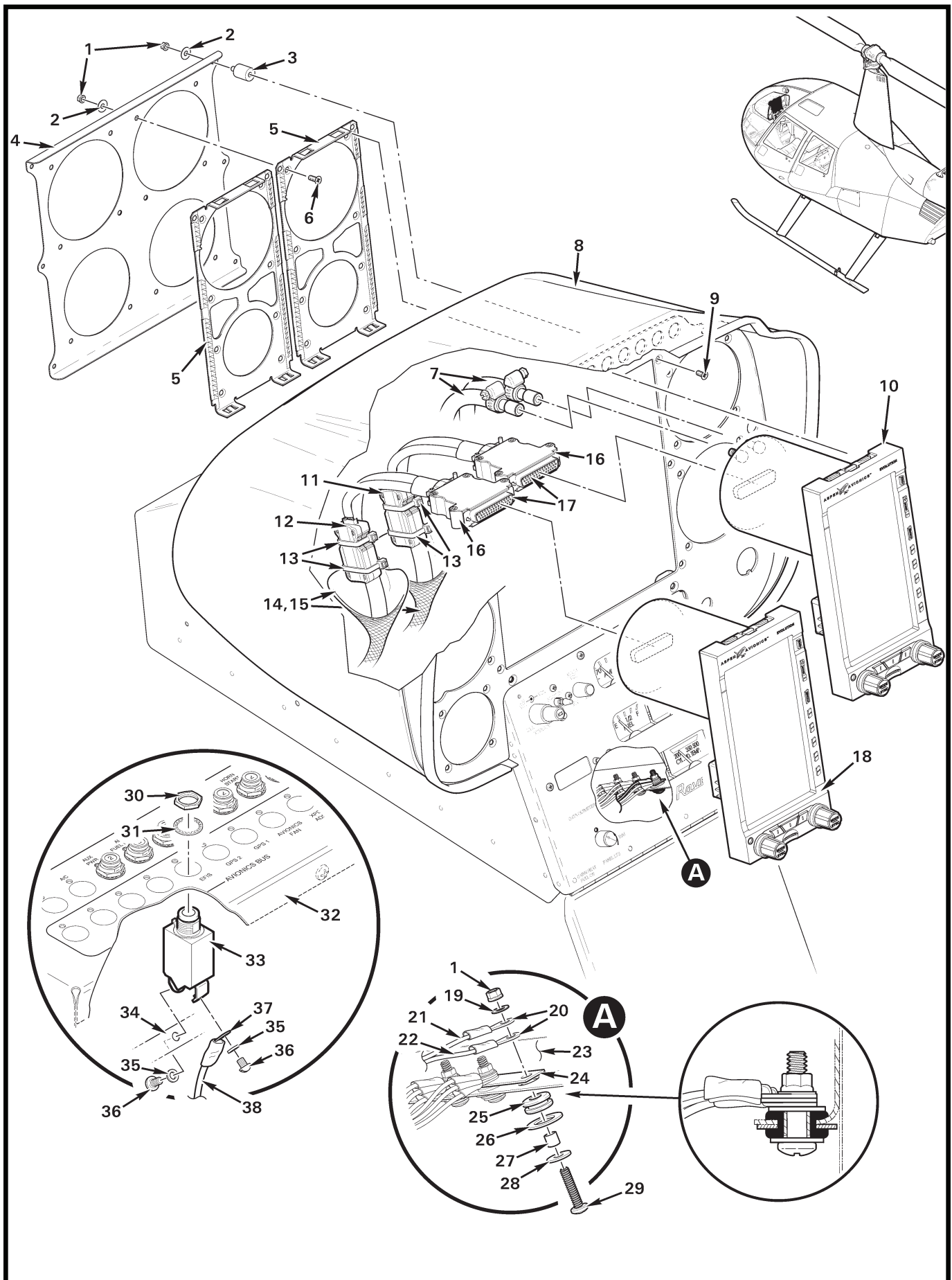

FIGURE AND INDEX NUMBER	PART NUMBER	DESCRIPTION	PARTS AVAIL	QTY PER ASSY
ASPEN PFD AND MFD INSTALLATION*				
95-15-1	MS21042L06	Nut	X	19
2	NAS1149FN616P	Washer	X	18
3	248-00002-001**	Isolator	X	6
4	C801-3	Panel	X	1
5	403-0003-001**	Bracket	O	2
6	MS24693-S26	Screw	X	12
7	A729-48	Tube (Ref, see Figure 95-71)		
8	G050	Console Assembly (Ref)		
9	MS24693-S24	Screw	X	6
10	EFD1000H**	PFD Display	O	1
11	920-00004-117**	Module	O	1
12	920-00004-105**	Module	O	1
13	MS3367-4-9	Ty-Rap	X	4
14	B247-607	Braid	X	A/R
15	7861K46	Heat Shrink	X	A/R
16	116-00022-002**	Connector	O	2
17	116-00026-006**	Backshell	O	2
18	910-00001-102**	MFD Display	O	1
19	NAS620-6L	Washer	X	1
20	B260-3	Terminal	X	2
21	-2557	Wire (Ref)		
22	-2616	Wire (Ref)		
23	C033	Console Assembly – Lower (Ref)		
24	A448-15	Bus Bar (3-hole)	X	1
25	MS35489-4	Grommet	X	1
26	NAS1149F0532P	Washer (install in grommet groove***)	X	1
27	C130-59	Spacer (install in grommet bore***)	X	1
28	NAS1149FN632P	Washer	X	1
29	B567-28	Screw	X	1
30	—	Nut	O	1
31	—	Lockwasher	O	1
32	C490-12	Circuit Breaker Panel (Ref)		
33	B297-7	Circuit Breaker (7.5 amp; includes items 30, 31, 35, and 36) . .	X	1
34	A448	Bus Bar (Ref)		
35	—	Washer	O	2
36	—	Screw	O	2
37	B260-2	Terminal	X	1
38	-2555	Wire (Ref; spliced with wire -2615 for MFD)		

NOTES * Eight-instrument console assembly only.
 ** Aspen Avionics part no.
 *** See detail showing assembled parts.

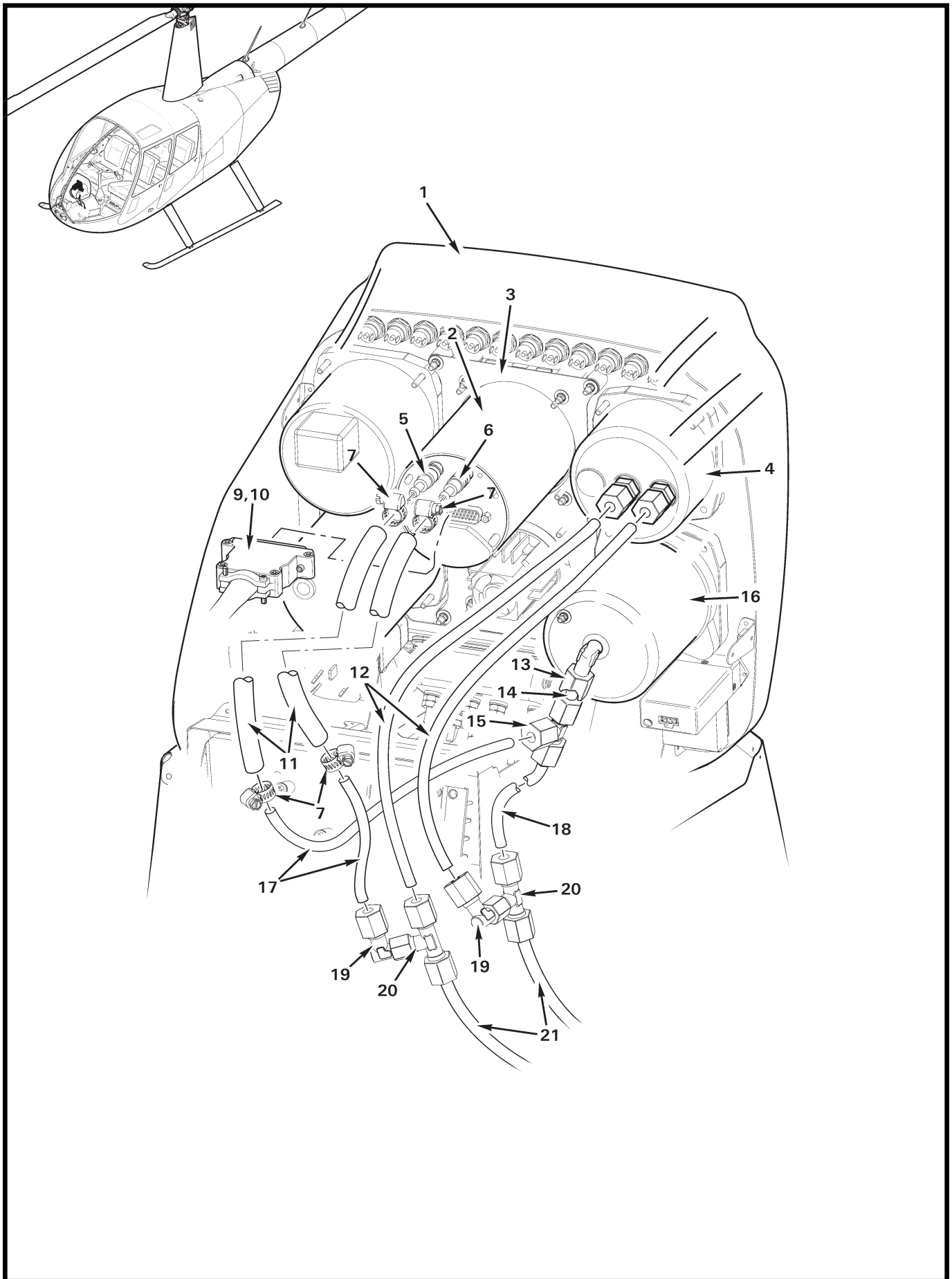

FIGURE AND INDEX NUMBER	PART NUMBER	DESCRIPTION	PARTS AVAIL	QTY PER ASSY
ASPEN PFD INSTALLATION – PITOT/STATIC LINES*				
95-17-1	G050-10	Console Assembly (Ref)		
2	EFD1000H**	PFD Display	O	1
3	C801-1	Plate (Ref)		
4	C599-2	Airspeed Indicator (Ref)		
5	275-00001-001**	Coupler (static)	O	1
6	275-00001-002**	Coupler (pitot)	O	1
7	271-00001-001	Clamp	X	4
8	10-4-2-N-0	Fitting	X	2
9	116-00022-002**	Connector (Ref, see Figure 95-63)		
10	116-00026-006**	Backshell (Ref, see Figure 95-63)		
11	A729-48	Tube	X	2
12	A729-23	Tube	X	2
13	40-4-2-N-0	Elbow	X	1
14	A729-27	Tube	X	1
15	70-4-N-0	Tee	X	1
16	A613	Altimeter (Ref)		
17	A729-52	Tube	X	2
18	A729-25	Tube	X	1
19	45-4-2-N-0	Elbow	X	2
20	60-4-2-N-0	Tee	X	2
21	A729-28	Tube (Ref)		

NOTES * Six-instrument console assembly.
 ** Aspen Avionics part no.

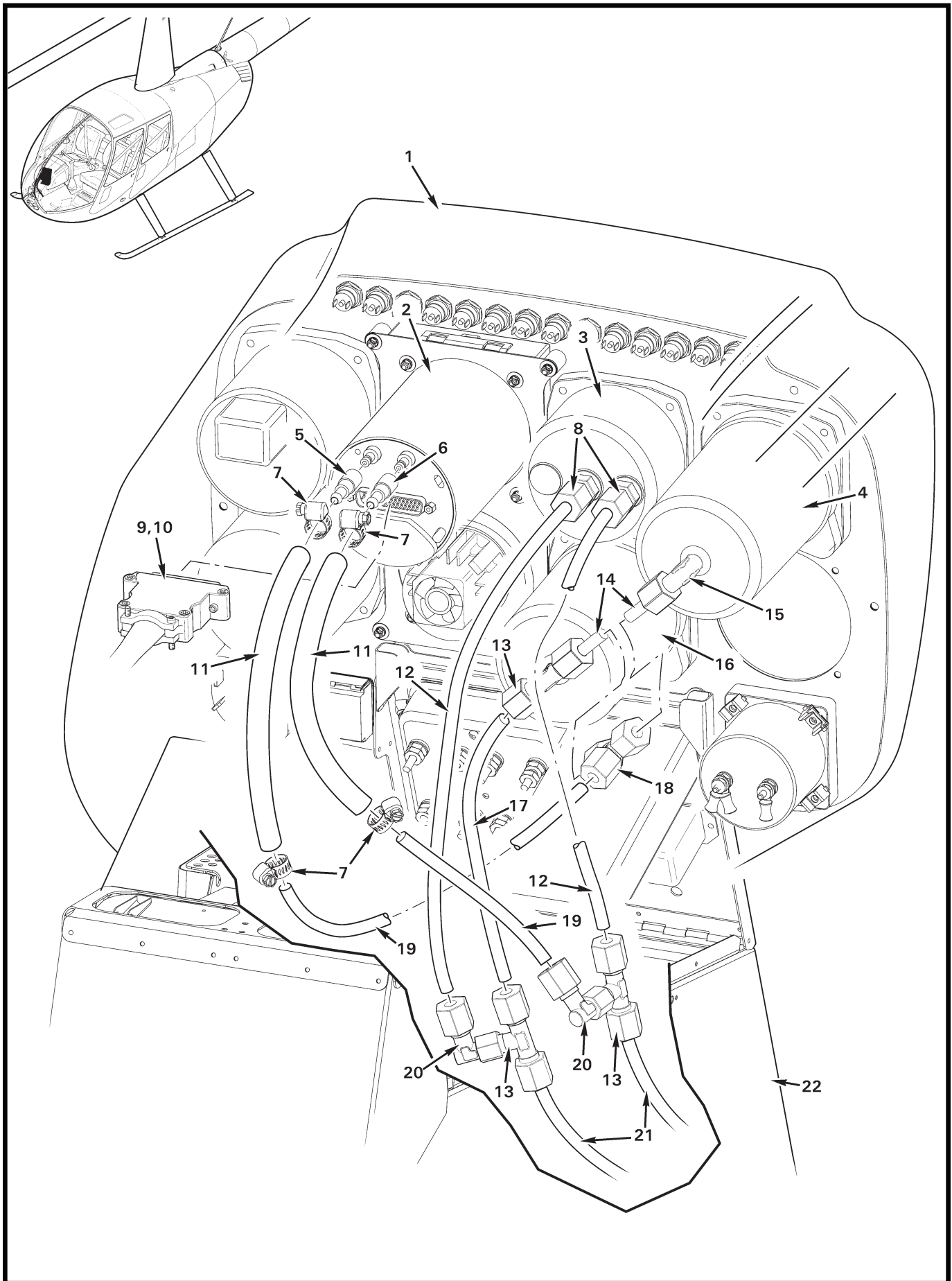

FIGURE AND INDEX NUMBER	PART NUMBER	DESCRIPTION	PARTS AVAIL	QTY PER ASSY
ASPEN PFD INSTALLATION – PITOT/STATIC LINES*				
95-19-1	G050-3	Console Assembly (Ref)		
2	EFD1000H**	PFD Display	O	1
3	C599-2	Airspeed Indicator (Ref)		
4	A602-1	Rate-of-Climb Indicator (Ref)		
5	275-00001-001**	Coupler (static)	O	1
6	275-00001-002**	Coupler (pitot)	O	1
7	271-00001-001**	Clamp	X	4
8	10-4-2-N-0	Fitting	X	2
9	116-00022-002**	Connector (Ref, see Figure 95-63)		
10	116-00026-006**	Backshell (Ref, see Figure 95-63)		
11	A729-48	Tube	X	2
12	A729-23	Tube	X	2
13	60-4-2-N-0	Tee	X	3
14	A729-27	Tube	X	2
15	40-4-2-N-0	Elbow	X	1
16	A613	Altimeter (Ref, see Figure 95-43)		
17	A729-25	Tube	X	1
18	70-4-N-0	Tee	X	1
19	A729-52	Tube	X	2
20	45-4-2-N-0	Elbow	X	2
21	A729-28	Tube (Ref)		
22	C033-1	Console Assembly (Ref)		

NOTES * Eight-instrument console assembly.
 ** Aspen Avionics part no.

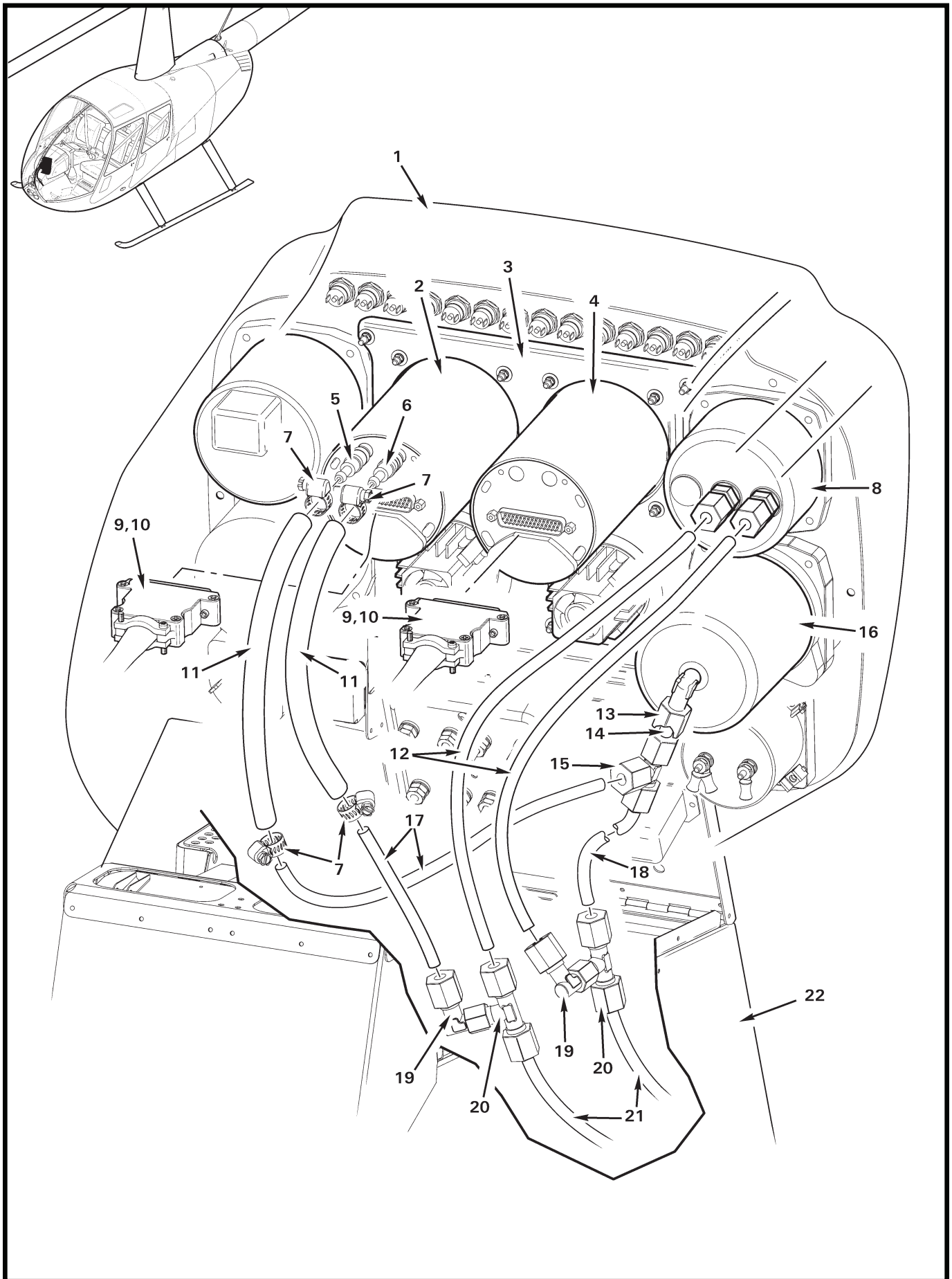

FIGURE AND INDEX NUMBER	PART NUMBER	DESCRIPTION	PARTS AVAIL	QTY PER ASSY
ASPEN PFD AND MFD INSTALLATION – PITOT/STATIC LINES*				
95-21-1	G050-3	Console Assembly (Ref)		
2	EFD1000H**	PFD Display	O	1
3	C801-2	Plate (Ref)		
4	EFD500H	MFD Display	O	1
5	275-00001-001**	Coupler (static)	O	1
6	275-00001-002**	Coupler (pitot)	O	1
7	271-00001-001**	Clamp	O	1
8	C599-2	Airspeed Indicator (Ref)		
9	116-00022-002**	Connector (Ref, see Figure 95-65)		
10	116-00026-006**	Backshell (Ref, see Figure 95-65)		
11	A729-48	Tube	X	2
12	A729-23	Tube	X	2
13	40-4-2-N-0	Elbow	X	1
14	A729-27	Tube	X	1
15	70-4-N-0	Tee	X	1
16	A613	Altimeter (Ref, see Figure 95-43)		
17	A729-52	Tube	X	1
18	A729-25	Tube	X	1
19	45-5-2-N-0	Elbow	X	2
20	60-4-2-N-0	Tee	X	2
21	A729-28	Tube (Ref)		
22	C033-1	Console Assembly (Ref)		

NOTES * Eight-instrument console assembly.
 ** Aspen Avionics part no.

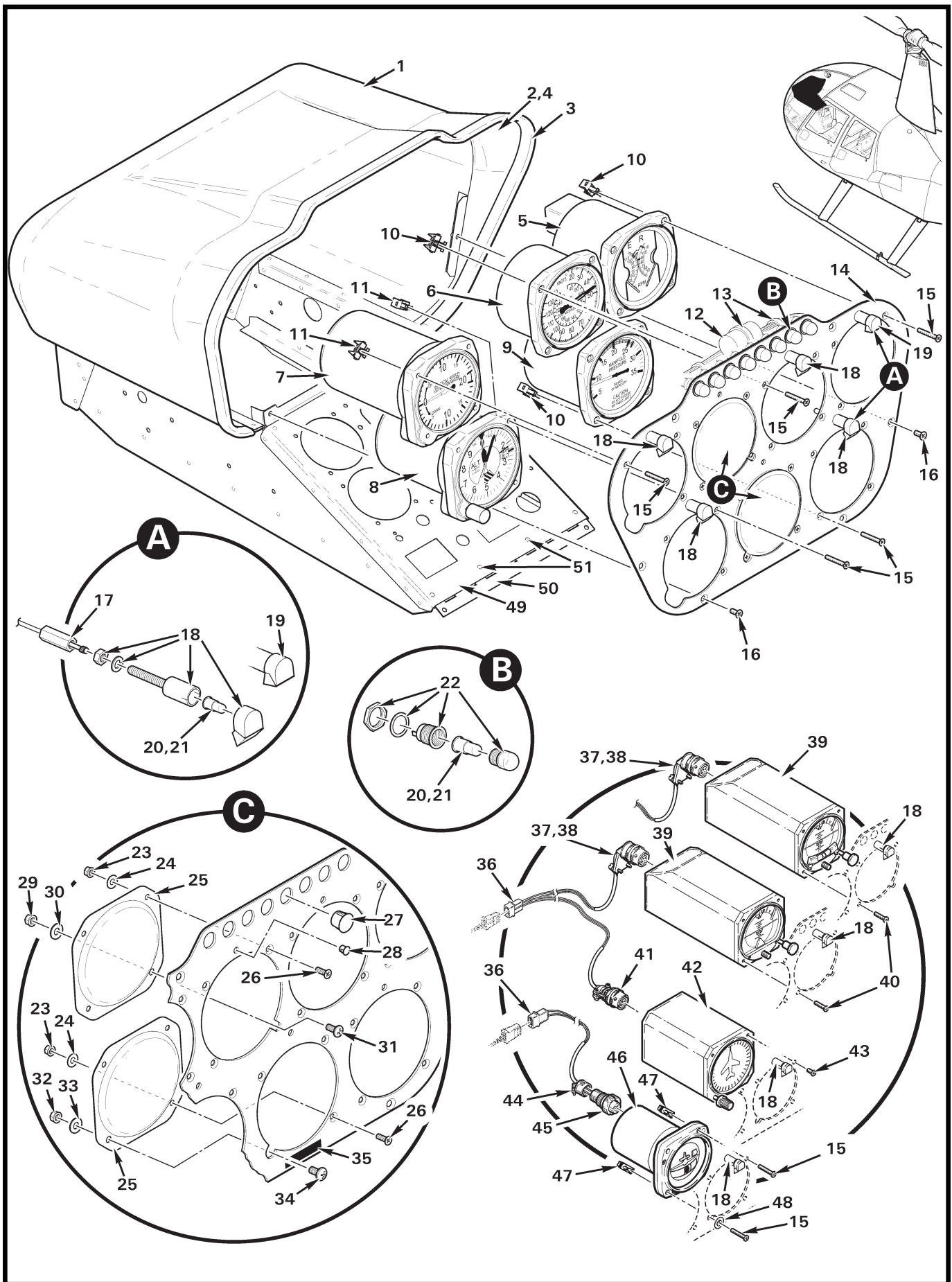

FIGURE AND INDEX NUMBER	PART NUMBER	DESCRIPTION	PARTS AVAIL	QTY PER ASSY
SEVEN-INSTRUMENT CONSOLE ASSEMBLY				
95-23-1	B051-3*	Console Assembly (Incl items 2 thru 4, and 49 thru 51)	X	1
	B051-9**	Console Assembly (Incl items 2 thru 4, and 49 thru 51)	X	1
2	B051-4	Visor Liner (install using item 4)	X	1
3	A226-11	Trim	X	A/R
4	B270-8qt	Adhesive	X	A/R
5	C792-2*	Engine/Rotor Tachometer (Ref, no longer available. To replace, order C792-4.)		
	C792-4	Engine/Rotor Tachometer	X	1
	C792-4R	Engine/Rotor Tachometer (overhaul exchange)	X	1
6	C599-1	Airspeed Indicator	X	1
7	A602-1	Rate-of-Climb Indicator	X	1
8	A613-1	Altimeter (In.-Hg)	X	1
	A613-2	Altimeter (Millibar, optional)	X	1
	A613-4	Altimeter (Metric, optional)	X	1
9	A600-4*	Manifold Pressure Gage	X	1
	A600-6**	Manifold Pressure Gage	X	1
10	MS33737-15C	Nut – Instrument	X	12
11	MS33737-13C	Nut – Instrument	X	6
12	A655-1	Time Delay – Low Fuel Warning	X	1
13	MS3367-4-9	Ty-Rap	X	3
14	B197-1	Face	X	1
15	MS24693-S32	Screw	X	A/R
16	MS24694-S4	Screw	X	6
17	B195-9	Connector Nut	X	A/R
18	B195-10	Post Light (14-volt, includes item 20)	X	A/R
	B195-11	Post Light (28-volt, includes item 21)	X	A/R
19	B195-14	Post Light (14-volt, narrow beam, tach only; includes item 20)	X	1
	B195-15	Post Light (28-volt, narrow beam, tach only; includes item 21)	X	1
20	B196-1	Lamp (14-volt ships)	X	A/R
21	B196-21	Lamp (28-volt ships)	X	A/R
22	B198-1	Light – Warning (Yellow; clutch actuator, main rotor temperature, main rotor chip, carbon monoxide***, starter, tail rotor chip, low fuel, and low rotor rpm. Order item 20 or 21 when replacing lamp.)	X	8

NOTES * Ship S/N 0001 thru 9999.
 ** Ship S/N 10001 and subsequent.
 *** If installed.

Continues

FIGURE AND INDEX NUMBER	PART NUMBER	DESCRIPTION	PARTS AVAIL	QTY PER ASSY
SEVEN-INSTRUMENT CONSOLE ASSEMBLY (Cont'd)				
95-23-23	MS21042L06	Nut	X	A/R
24	NAS1149FN616P	Washer	X	A/R
25	B190-6	Cover	X	A/R
26	MS24693-S27	Screw	X	A/R
27	2633	Hole Plug (if equipped)	X	1
28	2590	Hole Plug	X	A/R
29	MS21042L08	Nut	X	A/R
30	NAS1149FN816P	Washer	X	A/R
31	MS27039C0806	Screw	X	A/R
32	MS21042L3	Nut	X	A/R
33	NAS1149F0332P	Washer	X	A/R
34	MS27039C1-06	Screw	X	A/R
35	A743-1	Call Letters Plate (please specify call letters)	X	A/R
36	B263-12	Housing	X	1
	B263-1	Pin	X	2
37	11141L08-03B	Strain Relief (for Castleberry Indicator only)	X	1
38	MS3116F8-4S	Connector	X	1
39	B823-10	Attitude Indicator (optional; supersedes B823-1 and B823-4)	X	1
	B823-12	Attitude Indicator with inclinometer (optional; supersedes B823-3 and B823-6)	X	1
40	MS24693-S30	Screw	X	3
41	—	Connector (optional; supplied with item 42)	O	1
42	B823-11	Directional Gyro (optional; supersedes B823-2 and B823-5)	X	1
43	MS24693-S26	Screw	X	3
44	MS3057-4A	Strain Relief	X	1
45	MS3106A-10SL-3S	Connector	X	1
46	B329-1	Turn Coordinator	X	1
47	MS33737-12C	Instrument Nut	X	4
48	A3135-017-24A	Washer (countersunk; alternate part no. A3135-017-935)	X	1
49	B051-7	Face Assembly (O-540)	X	1
	B051-11	Face Assembly (IO-540)	X	1
50	A356-2	Hinge	X	1
51	MS20426AD3	Rivet	X	4

NOTES

Intentionally Blank

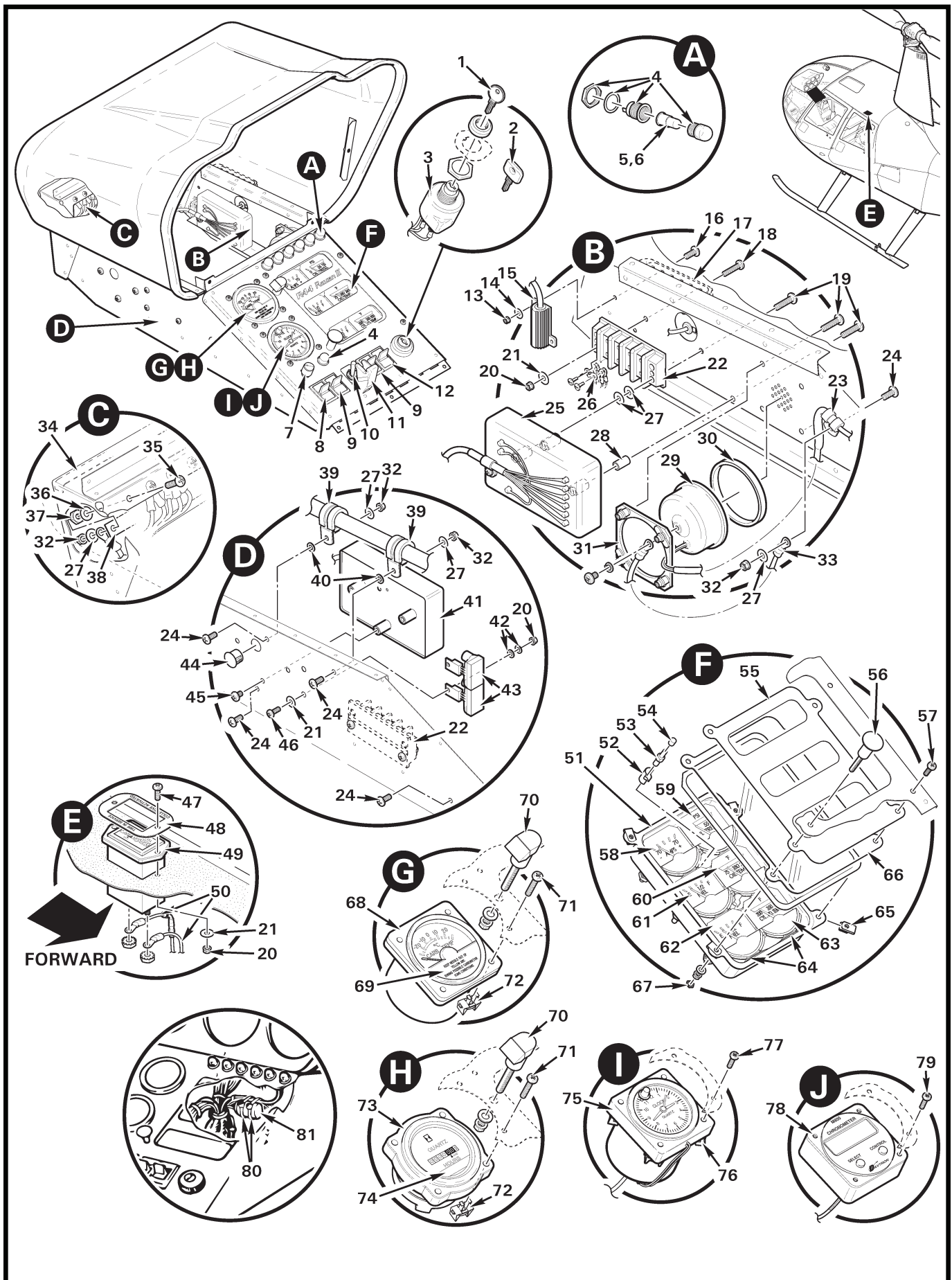

FIGURE AND INDEX NUMBER	PART NUMBER	DESCRIPTION	PARTS AVAIL	QTY PER ASSY
		SEVEN-INSTRUMENT CONSOLE ASSEMBLY		
95-27-1	R8096	Key – Duplicate (specify ship S/N and “PK” number when ordering)	X	1
2	D768-2	Key (blank; black plastic-coated, “R44” logo)	X	1
3	A661-1	Switch – Ignition (10-357200-1)	X	1
4	B198-1	Light – Warning (yellow; fuel filter, aux fuel pump, alternator, gov off, rotor brake; order with item 5 or 6 when replacing.) . .	X	1
	B198-2	Light – Warning (red; engine fire, oil pressure; order with item 5 or 6 when replacing.)	X	1
5	B196-1	Lamp (14-volt ships)	X	1
6	B196-21	Lamp (28-volt ships)	X	1
7	B398-1	Potentiometer	X	1
	MS91528-0C1B	Knob – Dimmer (supersedes 50-1WD-1G)	X	1
8	B184-3	Switch Assembly – Navigation Lights	X	1
9	B184-1	Switch Assembly – Alternator and Strobe	X	2
10	MS25068-23	Switch – Clutch	X	1
11	MS25224-1	Guard – Clutch Switch	X	1
12	B184-2	Switch Assembly – Battery	X	1
13	MS21042L04	Nut	X	2
14	NAS1149FN416P	Washer	X	2
15	RH25	Resistor (1.5Ω, 14 volt; earlier ships only)	X	1
16	MS35206-215	Screw	X	2
17	C696-1	Carbon Monoxide Detector (Ref, see Figure 96-59)		
18	MS35206-231	Screw	X	1
19	MS27039C0810	Screw	X	6
20	MS21042L06	Nut	X	5
21	NAS1149FN616P	Washer	X	5
22	601716-4	Terminal Block	X	2
23	MS21919WDG2	Clamp (14-volt ships)	X	1
	MS21919WDG4	Clamp (28-volt ships)	X	1
24	MS27039C0806	Screw	X	5
25	B395-1	Dimmer Assembly	X	1
26	601985-2	Jumper Tab (3 per terminal block)	X	6
27	NAS1149FN816P	Washer	X	13
28	A130-34	Spacer	X	2

NOTES

Continues

FIGURE AND INDEX NUMBER	PART NUMBER	DESCRIPTION	PARTS AVAIL	QTY PER ASSY
SEVEN-INSTRUMENT CONSOLE ASSEMBLY (Cont'd)				
95-27-29	B320-1	Horn – Low RPM Warning (14-volt ships)	X	1
	B320-3	Horn – Low RPM Warning (28-volt ships)	X	1
30	A479-2	Ring	X	1
31	A479-1	Plate	X	1
32	MS21042L08	Nut	X	11
33	B320-79	Wire – Jumper	O	1
34	A226-3	Seal (install using B270-4 or -13 adhesive)	X	A/R
35	B567-43	Screw	X	8
36	NAS1149DN832H	Washer	X	8
37	B301-8	Nut	X	8
38	A448-14	Bus Bar (8-hole)	X	1
39	MS21919WDG8	Clamp	X	2
40	NAS620-8	Washer	X	2
41	A569-6	Warning Unit – Low RPM (14-volt ships)	X	1
	A569-6R	A569-6 Warning Unit – Low RPM (overhaul exchange)	X	1
	A569-9	Warning Unit – Low RPM (28-volt ships)	X	1
	A569-9R	A569-9 Warning Unit – Low RPM (overhaul exchange)	X	1
42	NAS629-6	Washer	X	4
43	D359-1	Regulator – Voltage (28-volt ships only)	X	2
44	2633	Hole Plug	X	1
45	MS35206-241	Screw	X	3
46	MS35206-228	Screw	X	2
47	MS35206-229	Screw	X	2
48	B417-2	Faceplate	X	1
49	D830-2	Hourmeter (includes locknuts)	X	1
50	C059	Harness Assembly (Ref; wires -750, and -42)		
51	B144-3	Instrument Cluster (14-volt ships, includes items 52 thru 55, 58 thru 66, and 0015-00723 gasket)	X	1
	B144-4	Instrument Cluster (28-volt ships, includes items 52 thru 55, 58 thru 66, and 0015-00723 gasket)	X	1
52	A700-1	Barrier	X	2
53	100057017	Lamp (14-volt, gray base)	X	2
	100057022	Lamp (28-volt, red base)	X	2

NOTES

Continues

FIGURE AND INDEX NUMBER	PART NUMBER	DESCRIPTION	PARTS AVAIL	QTY PER ASSY
		SEVEN-INSTRUMENT CONSOLE ASSEMBLY (Cont'd)		
95-27-54	17P47	Cap (white)	X	2
55	D193-1	Plate – “R44 Astro” (7 or 9 hole panel)	X	1
	D193-2	Plate – “R44 Astro” (10 hole panel)	X	1
	D193-3	Plate – “R44 Cliper I” (7 or 9 hole panel)	X	1
	D193-4	Plate – “R44 Cliper I” (10 hole panel)	X	1
	D193-5	Plate – “R44 Raven I” (7 or 9 hole panel)	X	1
	D193-6	Plate – “R44 Raven I” (10 hole panel)	X	1
	D193-7*	Plate – “R44 Cliper II” (7 or 9 hole panel)	X	1
	D193-8*	Plate – “R44 Cliper II” (10 hole panel)	X	1
	D193-9*	Plate – “R44 Raven II” (7 or 9 hole panel)	X	1
	D193-10*	Plate – “R44 Raven II” (10 hole panel)	X	1
	D193-11*	Plate – “R44 Cliper I” (7 or 9 hole panel, bladder)	X	1
	D193-12*	Plate – “R44 Cliper I” (10 hole panel, bladder)	X	1
	D193-13*	Plate – “R44 Cliper II” (7 or 9 hole panel, bladder)	X	1
	D193-14*	Plate – “R44 Cliper II” (10 hole panel, bladder)	X	1
	D193-15*	Plate – “R44 Raven I” (7 or 9 hole panel, bladder)	X	1
	D193-16*	Plate – “R44 Raven I” (10 hole panel, bladder)	X	1
	D193-17*	Plate – “R44 Raven II” (7 or 9 hole panel, bladder)	X	1
	D193-18*	Plate – “R44 Raven II” (10 hole panel, bladder)	X	1
	D193-19*	Plate – “R44 Astro” (7 or 9 hole panel, bladder)	X	1
	D193-20*	Plate – “R44 Astro” (10 hole panel, bladder)	X	1
56	B195-17	Post Light – Switch Panel (14-volt ships, includes item 5) . . .	X	1
	B195-18	Post Light – Switch Panel (28-volt ships, includes item 6) . . .	X	1
57	MS35206-230	Screw	X	3
58	6246-00468	Ammeter	X	1
59	6246-00647	Oil Pressure Meter (14-volt ships)	X	1
	6246-00715	Oil Pressure Meter (28-volt ships)	X	1
60	6246-00090	Oil Temperature Meter (14-volt ships)	X	1
	6246-00717	Oil Temperature Meter (28-volt ships)	X	1
61	6246-00473	Fuel Quantity Meter (main tank, 14-volt ships)	X	1
	6246-00716	Fuel Quantity Meter (main tank, 28-volt ships)	X	1
62	6246-00473	Fuel Quantity Meter (aux tank, 14-volt ships)	X	1
	6246-00716	Fuel Quantity Meter (aux tank, 28-volt ships)	X	1
63	6246-00088	Cylinder Head Temp Meter (14-volt ships)	X	1
	6246-00718	Cylinder Head Temp Meter (28-volt ships)	X	1

NOTES * Ship S/N 10001 and subsequent.

Continues

FIGURE AND INDEX NUMBER	PART NUMBER	DESCRIPTION	PARTS AVAIL	QTY PER ASSY
SEVEN-INSTRUMENT CONSOLE ASSEMBLY (Cont'd)				
95-27-64	—	Desiccant Bag	O	2
65	B162-1	Clipnut	X	3
66	0003-00434	Crystal (clear plastic)	X	1
67	B330-6	Palnut	X	1
68	C604-6	Gage – Carb Air Temp (14-volt ships, includes item 69 and connector)	X	1
	C604-8	Gage – Carb Air Temp (28-volt ships, includes item 69 and connector)	X	1
69	—	Placard (carb heat instructions)	X	1
70	B195-10	Post Light Assembly (14-volt ships, includes item 5)	X	1
	B195-11	Post Light Assembly (28-volt ships, includes item 6)	X	1
71	MS35206-232	Screw	X	1
72	MS33737-12C	Nut – Instrument	X	4
73	D830-1	Hourmeter	X	1
74	B387-3	Decal – “Collective Activated”	X	1
75	A072-7	Clock Assembly (14-volt; bottom LTS; includes item 76 and light tray assembly; not shown)	X	1
	A072-8	Clock Assembly (28-volt; bottom LTS; includes item 76 and light tray assembly)	X	1
	A072-12	Clock Assembly (14-volt; top LTS; includes item 76 and light tray assembly; not shown)	X	1
	A072-13	Clock Assembly (28-volt; top LTS; includes item 76 and light tray assembly; not shown)	X	1
76	6-32	Nut – Instrument	O	4
77	MS35206-234	Screw	X	4
78	A064-3	Chronometer Assembly (14-volt; Davtron 800)	X	1
	A064-4	Chronometer Assembly (28-volt; Davtron 800)	X	1
79	—	Screw (supplied with item 78)	O	4
80	MS3367-5-9	Ty-Rap	X	2
81	B280-4	Relay – Governor “OFF” Warning (location for earlier ships only)	X	1

NOTES

Intentionally Blank

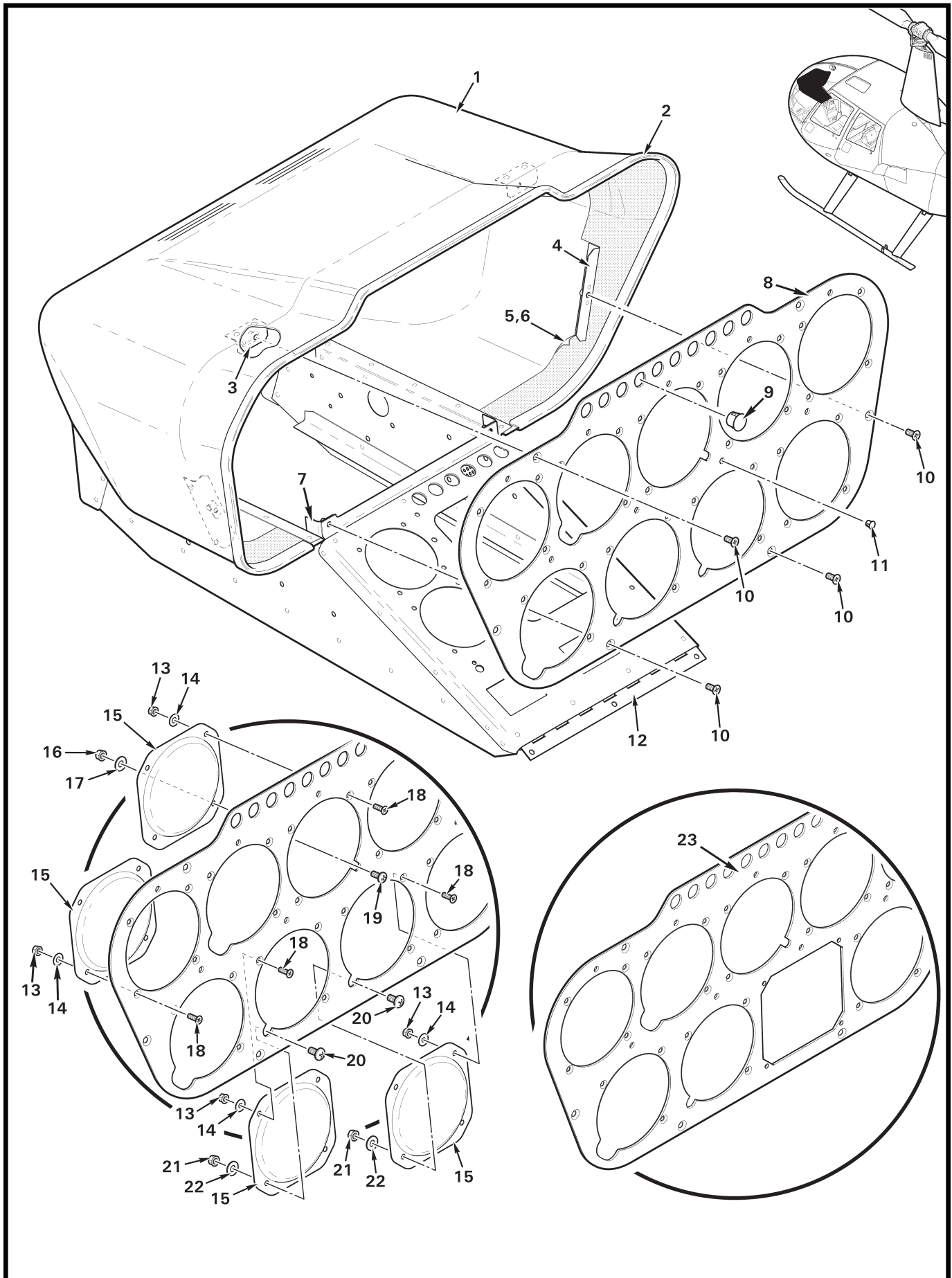

FIGURE AND INDEX NUMBER	PART NUMBER	DESCRIPTION	PARTS AVAIL	QTY PER ASSY
NINE-INSTRUMENT CONSOLE ASSEMBLY				
95-33-1	B051-10*	Console Assembly (Incl items 2 thru 7, 12, and lower panels; IO-540 ships)	X	1
	B051-6*	Console Assembly (Incl items 2 thru 7, 12, and lower panels); O-540 ships [not shown])	X	1
2	A226-11	Trim	X	A/R
3	B181-2	Angle	X	2
4	B181-3	Angle	X	2
5	B051-8	Liner (vinyl)	X	1
6	B270-8qt	Adhesive (to attach items 2 and 10; 8-oz can)	X	A/R
7	A365-11	Angle	X	2
8	B206-1	Face	X	1
9	2633	Hole Plug	X	A/R
10	MS24694-S4	Screw	X	6
11	2590	Hole Plug (if no post light installed)	X	A/R
12	A356-2	Hinge	X	1
13	MS21042L06	Nut	X	A/R
14	NAS1149FN616P	Washer	X	A/R
15	B190-6	Cover	X	A/R
16	MS21042L08	Nut	X	A/R
17	NAS1149FN816P	Washer	X	A/R
18	MS24693-S27	Screw	X	A/R
19	MS27039C0806	Screw	X	A/R
20	MS27039C1-06	Screw	X	A/R
21	MS21042L3	Nut	X	A/R
22	NAS1149F0332P	Washer	X	A/R
23	B206-3	Face (used when HSI is installed)	X	1

NOTES * For instrument and other component installation, see Figure 95-1 and Figure 95-5.

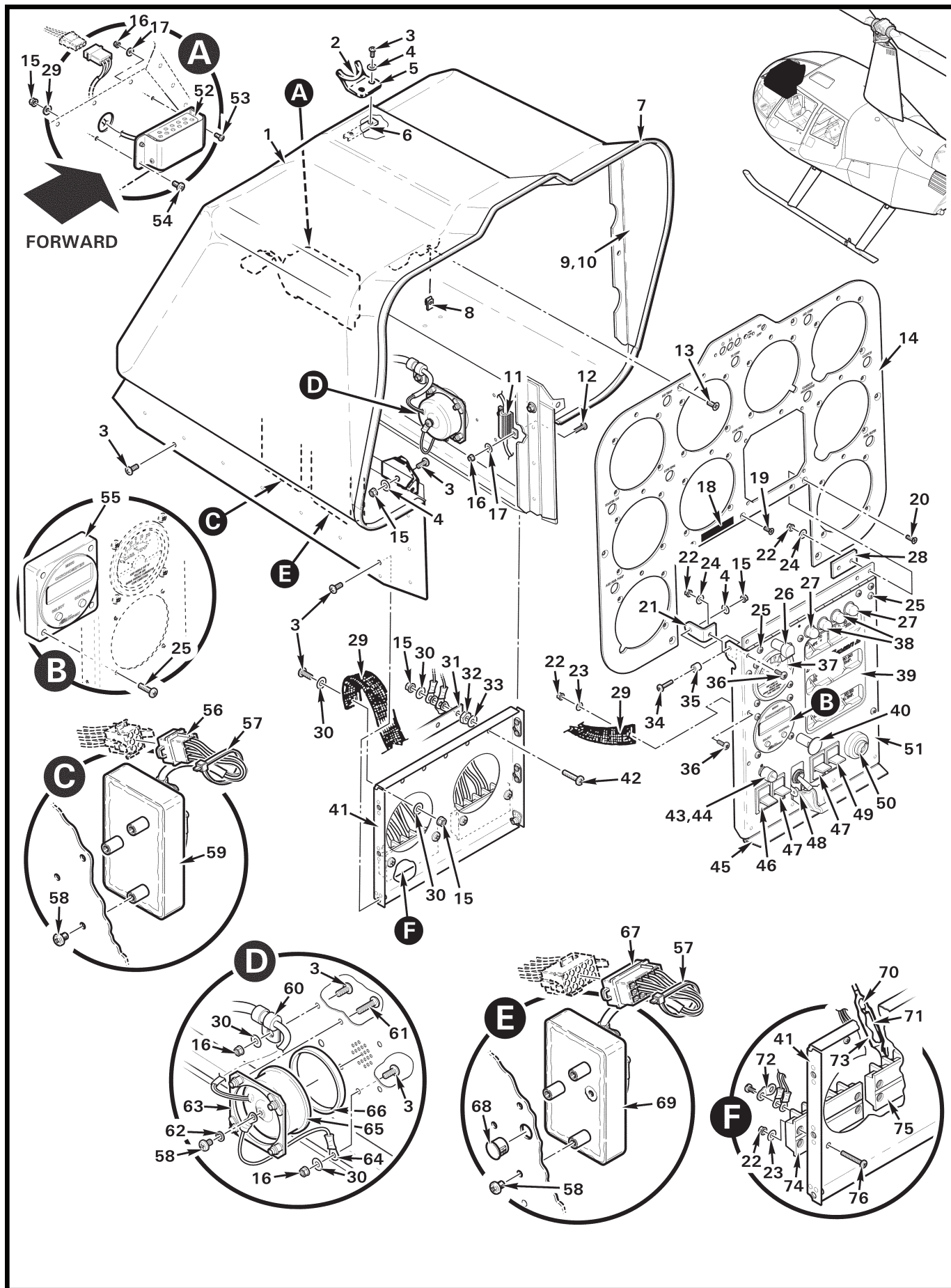

FIGURE AND INDEX NUMBER	PART NUMBER	DESCRIPTION	PARTS AVAIL	QTY PER ASSY
		TEN-INSTRUMENT CONSOLE ASSEMBLY (IFR TRAINER)		
95-35-1	A077-3	Shell Assembly (Incl items 3, 4, 7, 9, 15, and 41)	X	1
2	MS35489-16	Grommet	X	1
3	MS27039C0806	Screw	X	16
4	NAS1149FN832P	Washer	X	4
5	B255-3	Console Support Assembly (Incl item 2)	X	1
6	A738-21	Gang Channel	X	1
7	A226-11	Trim	X	A/R
8	B162-2	Clipnut	X	6
9	A077-2	Liner (install using item 10)	X	1
10	B270-8qt	Adhesive	X	A/R
11	RH25	Resistor (1.5 Ω, 14-volt ships)	X	1
	D359-1	Regulator Assembly (28-volt ships; not shown)	X	1
12	MS35206-215	Screw	X	2
13	MS24694-S3	Screw (see Figure 95-19 for instruments and post lights)	X	6
14	A981-1	Face	X	1
15	MS21042L08	Nut	X	13
16	MS21042L04	Nut	X	2
17	NAS1149FN416P	Washer	X	2
18	A743-1	Call Letters Plate (domestic ships only; please specify call letters)	X	1
19	MS24693-S26	Screw (center)	X	1
20	MS24693-S27	Screw (outboard)	X	4
21	A963-1	Angle	X	2
22	MS21042L06	Nut	X	17
23	NAS1149FN616P	Washer	X	6
24	NAS1149FN632P	Washer	X	11
25	MS35206-228	Screw	X	5
26	B195-10	Post Light (14-volt ships; includes item 77)	X	1
	B195-11	Post Light (28-volt ships; includes item 77)	X	1
27	B198-1*	Warning Light (yellow; low voltage and governor off)	X	2
28	A988-1	Doubler	X	2
29	A989-1	Strap	X	2
30	NAS1149FN816P	Washer	X	13

NOTES * Order item 77 when replacing.

Continues

FIGURE AND INDEX NUMBER	PART NUMBER	DESCRIPTION	PARTS AVAIL	QTY PER ASSY
		TEN-INSTRUMENT CONSOLE ASSEMBLY (IFR TRAINER) (Cont'd)		
95-35-31	A448-8	Bus Bar	X	1
32	AN340B8	Nut	X	5
33	NAS1149DN832H	Washer	X	5
34	MS27039C0808	Screw	X	2
	MS24694-23	Screw (if DME installed)	X	1
35	A130-37	Spacer	X	2
	B220-1	Spacer (if DME installed)	X	2
36	MS35206-229	Screw	X	4
37	C604-6	Carb Air Temp Gage (includes Connector)	X	1
38	B198-2*	Warning Light (red; oil pressure and engine fire)	X	1
39	B144-3	Instrument Cluster Assembly (14-volt ships; see also Figure 95-1)	X	1
	B144-4	Instrument Cluster Assembly (28-volt ships; see also Figure 95-1)	X	1
	D193-2	Plate – "R44 Astro"	X	1
	D193-4	Plate – "R44 Clipper"	X	1
	D193-6	Plate – "R44 Raven"	X	1
	D193-8	Plate – "R44 Clipper II"	X	1
	D193-10	Plate – "R44 Raven II"	X	1
	0003-00434	Crystal (clear plastic)	X	1
40	B195-1	Post Light – Switch Panel (14-volt ships; replace lamp with item 77)	X	1
	B195-18	Post Light – Switch Panel (14-volt ships; replace lamp with item 77)	X	1
41	A974-1	Web Assembly	X	1
42	MS35206-247	Screw	X	5
43	MS91528-OC1B	Knob – Dimmer (supersedes 50-1WD-1G)	X	1
44	B398-1	Potentiometer	X	1
45	A033-12	Hinge	X	1
46	B184-3	Switch Assembly – NAV Lights	X	1
47	B184-1	Switch Assembly – Alternator and Strobe Light	X	2
48	MS25068-23	Switch – Clutch (7664K5)	X	1
	MS25224-1	Guard (red plastic)	X	1
49	B184-2	Switch – Battery	X	1

NOTES * Order item 77 when replacing.

Continues

FIGURE AND INDEX NUMBER	PART NUMBER	DESCRIPTION	PARTS AVAIL	QTY PER ASSY
		TEN-INSTRUMENT CONSOLE ASSEMBLY (IFR TRAINER) (Cont'd)		
95-35-50	A661-1	Switch – Ignition (see also Figure 95-1)	X	1
51	A980-4	Face Assembly (Ref)		
52	C696-1	Carbon Monoxide Detector Assembly (includes wires, housing, and pins)	X	1
53	MS35206-214	Screw	X	1
54	MS35206-232	Screw	X	1
55	A064-3*	Chronometer (14-volt ships; see also Figure 95-5)	X	1
	A064-4*	Chronometer (28-volt ships; see also Figure 95-5)	X	1
56	B263-18	Housing	X	1
	B263-1	Pin	X	6
57	MS3367-5-9	Ty-Rap	X	2
58	MS35206-241	Screw	X	7
59	B395-1	Dimmer Assembly (includes item 56)	X	1
60	MS21919WDG2	Clamp	X	1
61	MS27039C0810	Screw	X	4
62	B332-42	Lockwasher	X	1
63	A479-1	Plate	X	1
64	B320-79	Wire – Jumper	X	1
65	B320-1	Horn Assembly – Low RPM Warning (14-volt ships)	X	1
	B320-1	Horn Assembly – Low RPM Warning (28-volt ships)	X	1
66	A479-2	Ring	X	1
67	B263-22	Housing (14-volt ships)	X	1
	B263-1	Pin	X	11
	B263-24	Housing (28-volt ships)	X	1
	B263-1	Pin	X	11
68	2633	Hole Plug	X	1
69	A569-6	Low RPM Warning Unit (14-volt ships; includes item 67)	X	1
	A569-9	Low RPM Warning Unit (28-volt ships; includes item 67)	X	1
70	B261-2	Splice	X	1
71	R5277	Resistor (20Ω, 14-volt ships only)	X	1
72	601985-2	Jumper Tab	X	6
73	B158-6	Heat Shrink	X	A/R

NOTES * Chronometer (digital) standard on IFR Trainer, optional on Ten-Instrument panel. For Clock Assembly (analog) Installation, see Figure 95-5.

Continues

FIGURE AND INDEX NUMBER	PART NUMBER	DESCRIPTION	PARTS AVAIL	QTY PER ASSY
TEN-INSTRUMENT CONSOLE ASSEMBLY (IFR TRAINER) (Cont'd)				
95-35-74	601716-4	Terminal Block (warning lights; includes item 72)	X	1
75	601716-4	Terminal Block (instrument lights; includes item 72)	X	1
76	MS35206-231	Screw (two for each terminal block)	X	4
77	B196-1	Lamp (14-volt; not shown)	X	5
	B196-21	Lamp (28-volt; not shown)	X	5
NOTES				

Intentionally Blank

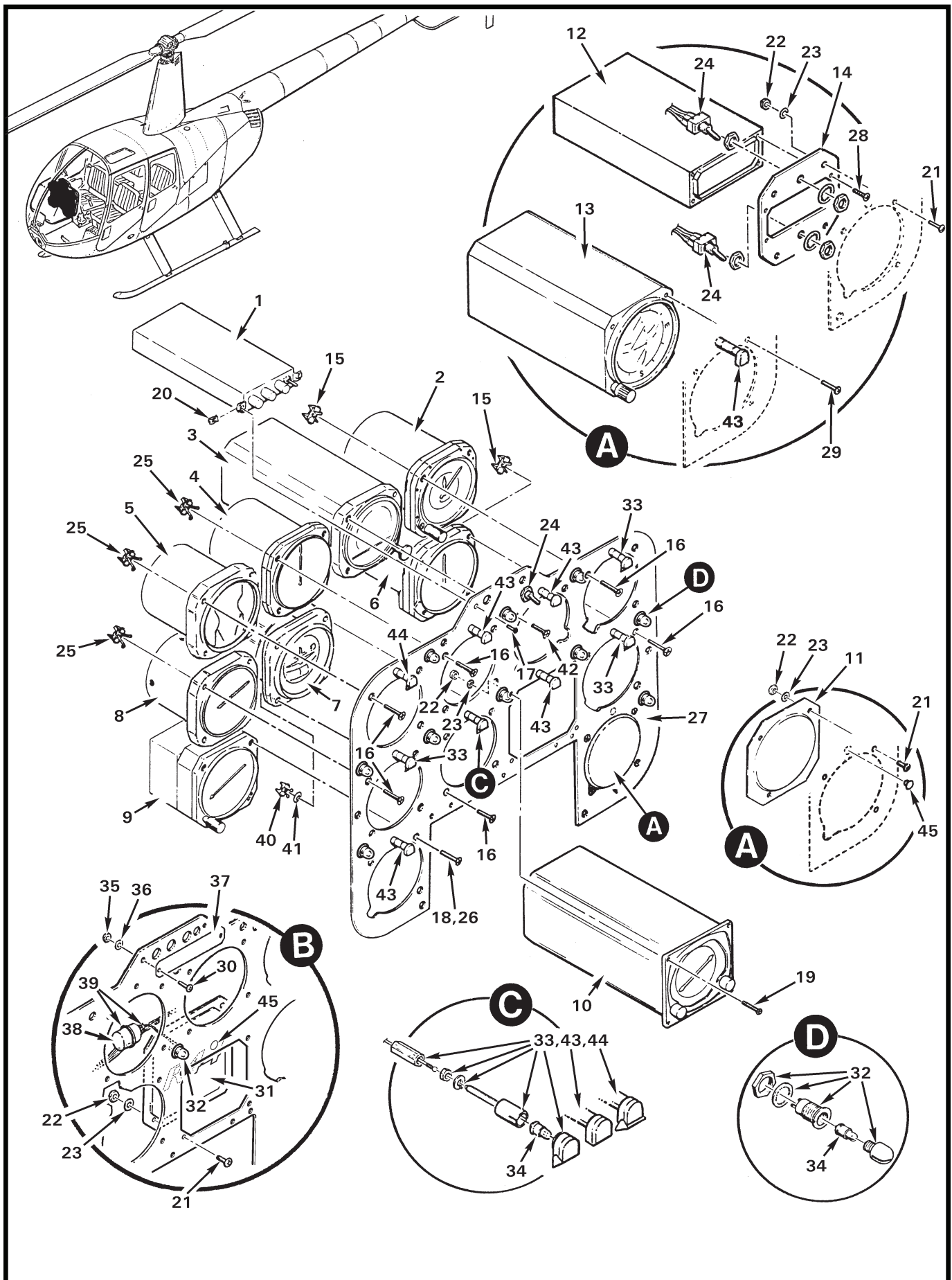

FIGURE AND INDEX NUMBER	PART NUMBER	DESCRIPTION	PARTS AVAIL	QTY PER ASSY
		TEN-INSTRUMENT CONSOLE ASSEMBLY (IFR TRAINER)		
95-41-1	KR 22	Marker Beacon (Bendix/King includes items 17 and 20)	O	1
2	KEA 129	Altimeter (encoding, Bendix/King)	O	1
3	B191-3	Attitude Gyro (14-volt, optional)	O	1
	B191-7	Attitude Gyro (14-volt, optional, with inclinometer)	O	1
	B191-8	Attitude Gyro (28-volt, optional)	O	1
	B191-12	Attitude Gyro (28-volt; optional, with inclinometer)	O	1
4	C599-1	Airspeed Indicator	X	1
5	C792-2*	Engine/Rotor Tachometer (Ref, no longer available. To replace, order C792-4.)		
	C792-4	Engine/Rotor Tachometer	X	1
	C792-4R	C792-4 Engine/Rotor Tachometer (overhaul exchange)	X	1
6	A602-1	Rate-of-Climb Indicator	X	1
	A602-2	Rate-of-Climb Indicator (IVSI, optional)	X	1
7	B329-1	Turn Coordinator (1394-T100-7Z)	X	1
8	A600-4*	Manifold Pressure Gage	X	1
	A600-6**	Manifold Pressure Gage	X	1
9	KI 227-01	ADF Indicator (Bendix/King, includes item 26)	O	1
	KI 227-00	ADF Indicator (Bendix/King, includes item 26)	O	1
10	KI 525A	Pictorial Nav Indicator (Bendix/King, includes item 19)	O	1
11	B190-6	Cover	X	A/R
12	KDI 574	DME Indicator (Bendix/King, includes item 28)	O	1
13	KI 203	VOR Indicator (TSO'd, Bendix/King; includes item 29)	O	1
	KI 204	VOR Indicator (Bendix/King, includes item 29)	O	1
14	A590-1	Cover Plate (required if item 12 is installed)	X	1
15	MS33737-13C	Instrument Nut	X	6
16	MS24693-S32	Screw	X	A/R
17	—	Screw	X	2
18	MS24693-S27	Screw (use with items 11, 22, and 23 when no instrument is installed)	X	A/R
19	—	Screw	O	4
20	—	Clipnut	O	2
21	MS24693-S27	Screw	X	4

NOTES * Ship S/N 0001 thru 9999.
 ** Ship S/N 10001 and subsequent.

Continues

FIGURE AND INDEX NUMBER	PART NUMBER	DESCRIPTION	PARTS AVAIL	QTY PER ASSY
		TEN-INSTRUMENT CONSOLE ASSEMBLY (IFR TRAINER) (Cont'd)		
95-41-22	MS21042L06	Nut	X	A/R
23	NAS1149FN616P	Washer	X	A/R
24	B300-1	Switch (on-off; includes B227-3 lockwasher and B227-4 dress nut)	X	A/R
25	MS33737-15C	Instrument Nut	X	12
26	—	Screw	O	3
27	A981-1*	Face (see also Figure 95-13)	X	1
	A981-2**	Face (see also Figure 95-13)	X	1
28	—	Screw	O	4
29	—	Screw	O	3
30	MS35206-215	Screw	X	2
31	B190-4	Cover (Ref, no longer available)		
32	B198-1*	Warning Light (yellow; order item 34 when replacing)	X	10
33	B195-10	Post Light (14-volt ships; includes item 34)	X	A/R
	B195-11	Post Light (28-volt ships; includes item 34)	X	A/R
34	B196-1	Lamp (14-volt)	X	A/R
	B196-21	Lamp (28-volt)	X	A/R
35	MS21042L04	Nut	X	2
36	NAS1149FN416P	Washer	X	2
37	A173-2	Cover (required if item 1 is not installed)	X	1
38	A655-1	Time Delay – Low Fuel Warning	X	1
39	MS3367-4-9	Ty-Rap	X	1
40	MS33737-12C	Instrument Nut	X	4
41	A3135-017-935	Washer (countersunk)	X	4
42	MS24693-S30	Screw	X	3
43	B195-12	Post Light (14-volt ships; includes item 34)	X	5
	B195-13	Post Light (28-volt ships; includes item 34)	X	5
44	B195-14	Post Light (14-volt ships; narrow beam, tach only. Includes item 34.)	X	1
	B195-15	Post Light (28-volt ships; narrow beam, tach only. Includes item 34.)	X	1
45	2590	Hole Plug (if no post light installed)	X	A/R

NOTES * Ship S/N 0001 thru 9999.
** Ship S/N 10001 and subsequent.

Intentionally Blank

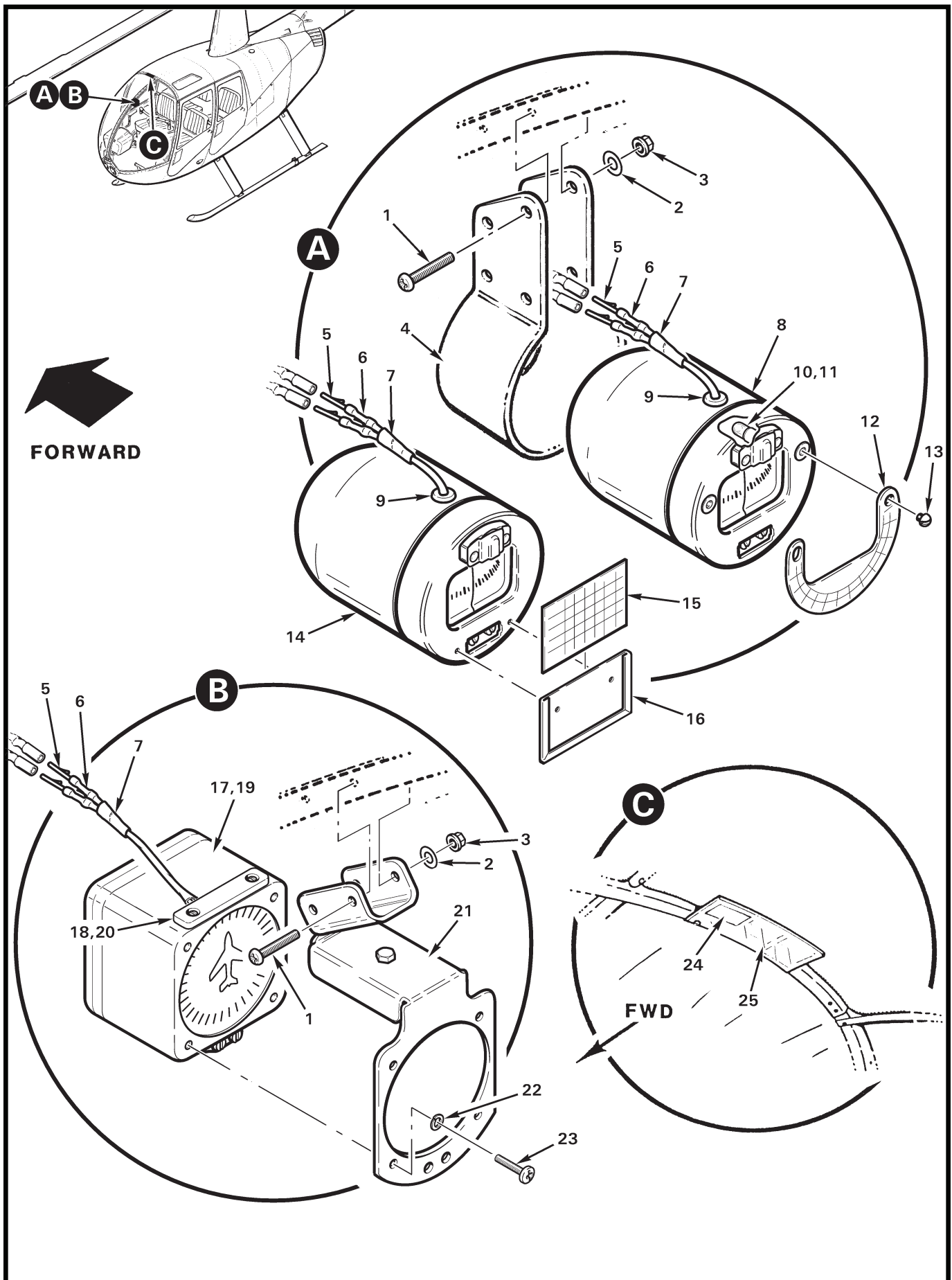

FIGURE AND INDEX NUMBER	PART NUMBER	DESCRIPTION	PARTS AVAIL	QTY PER ASSY
COMPASS INSTALLATION				
95-45-1	AN515UB8R20	Screw	X	4
2	NAS1149DN816J	Washer	X	4
3	NAS1291C08M	Nut	X	4
4	C685-1	Mount – Compass	X	1
5	B263-1	Pin	X	2
6	B158-2	Heat Shrink (0.125 in. dia., black)	X	A/R
7	B158-3	Heat Shrink (0.187 in. dia., black)	X	A/R
8	A022-3	Compass Assembly (14-volt ships. Includes items 5 thru 7, 9, 10, 12, and 13.)	X	1
	A022-4	Compass Assembly (28-volt ships. Includes items 5 thru 7, 9 and 11 thru 13.)	X	1
9	MS35489-4	Grommet	X	1
10	B196-1	Lamp (14-volt ships)	X	1
11	B196-21	Lamp (28-volt ships)	X	1
12	—	Deviation Plate	O	1
13	—	Screw	O	2
14	A022	Compass Assembly (Ref, no longer available. Superseded by item 8. For earlier R44s with items 15 and 16 installed.)		
15	C23-807	Deviation Card	X	1
16	C23-805M	Mount – Deviation Card	X	1
17	B148-2*	Compass Assembly – Vertical Card (14-volt ships. Includes items 5 thru 7, 18 and 23.)	X	1
18	—	Light Bar (14-volt; Ref)	O	1
19	B148-5*	Compass Assembly – Vertical Card (28-volt ships. Includes items 5 thru 7, 20 and 23.)	X	1
20	PAI-28V	Light Bar (28-volt; Ref)	O	1
21	B339-2	Mount (vertical card compass)	X	1
22	MS35338-136B	Lockwasher	X	4
23	—	Screw	O	4
24	PAI-DE-CARD	Deviation Placard (vertical card compass)	X	1
25	A725-3	Mount (Ref, see Figure 11-5)		

NOTES * Optional.

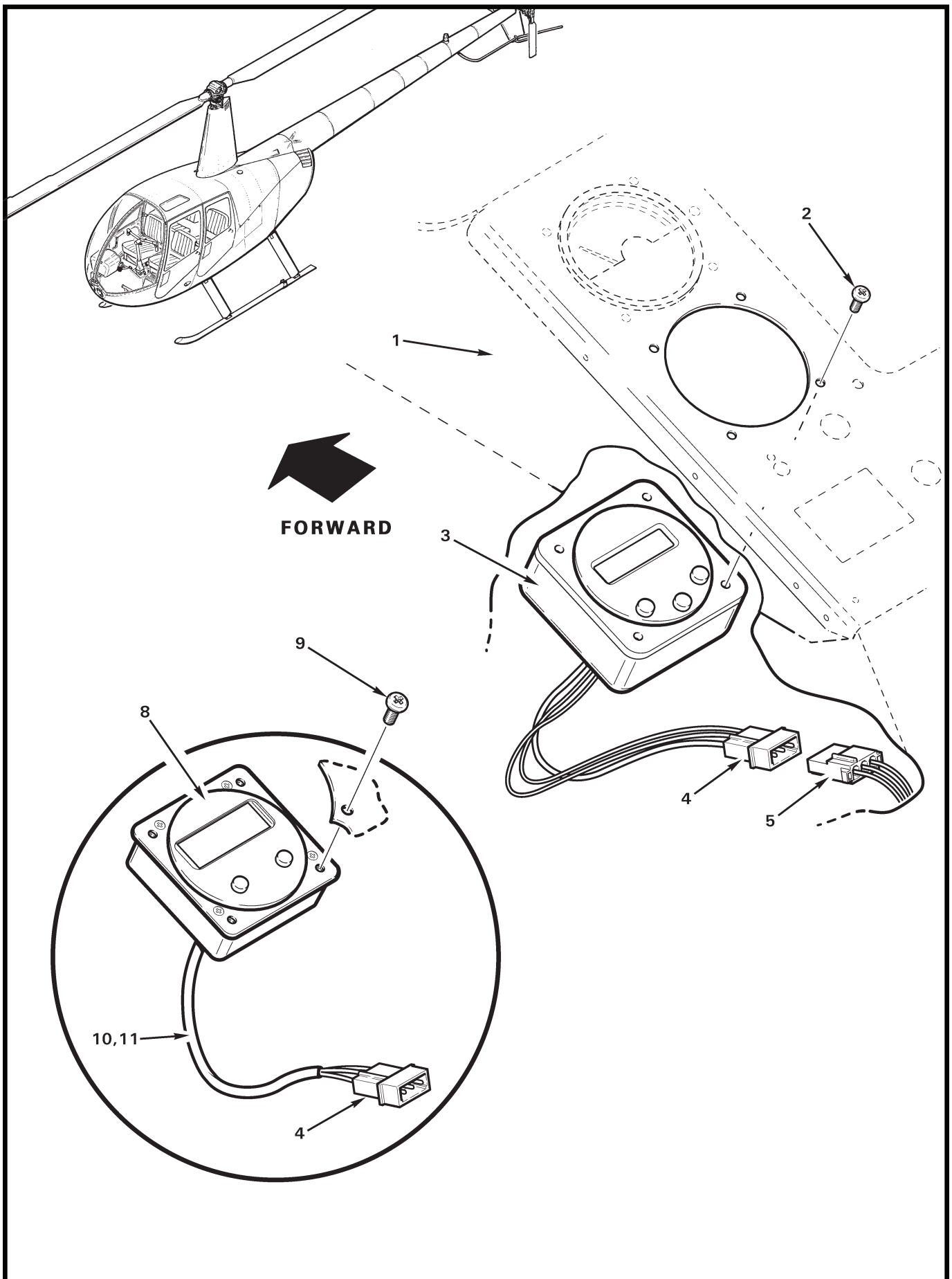

FIGURE AND INDEX NUMBER	PART NUMBER	DESCRIPTION	PARTS AVAIL	QTY PER ASSY
DIGITAL CLOCK INSTALLATION				
95-47-1	B050	Console Assembly (Ref)		
2	MS35206-228	Screw	X	4
3	A064-3	Chronometer Assembly (14-volt; Astrotech part no. AT4210R0. Includes items 4, 6, and wiring.)	X	1
	A064-4	Chronometer Assembly (28-volt; Astrotech part no. AT4220R0. Includes items, 4, 7, and wiring.)	X	1
4	B263-14	Housing	X	1
	B263-1	Pin	X	3
5	B263-15	Housing	X	1
	B263-2	Socket	X	3
6	B196-5	Lamp (14-volt, not shown)	X	1
7	B196-25	Lamp (28-volt, not shown)	X	1
8	A064-3*	Chronometer Assembly (14-volt; Davtron part no. 800-14-volt. Includes items 4, 9, 10, and wiring.)	X	1
	A064-4*	Chronometer Assembly (28-volt; Davtron part no. 800-28-volt. Includes items 4, 9, 11, and wiring.)	X	1
9	—	Screw (4-40 x 3/8)	O	4
10	B158-2	Heat Shrink	X	A/R
11	B158-402	Heat Shrink	X	A/R

NOTES * If equipped.

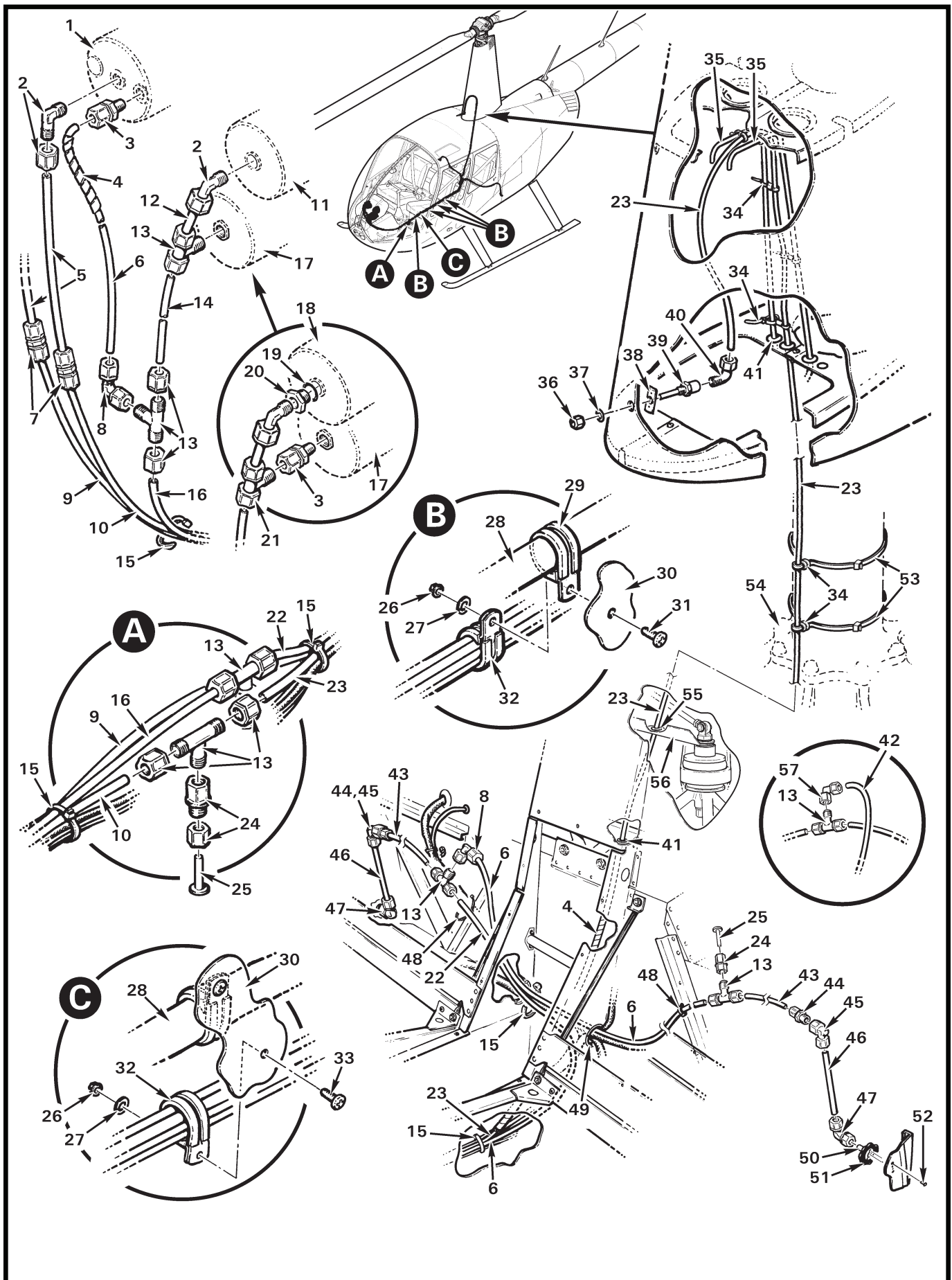

FIGURE AND INDEX NUMBER	PART NUMBER	DESCRIPTION	PARTS AVAIL	QTY PER ASSY
PITOT/STATIC LINES INSTALLATION*				
95-49-1	C599-1	Airspeed Indicator (Ref)		
2	40-4-2-N-0	Elbow	X	2
3	10-4-2-N-0	Fitting ([2] per ship required when item 18 is installed)	X	1
4	B161-4	Spirap	X	A/R
5	A729-21	Tube	X	2
6	A729-23	Tube	X	2
7	15-4-N-0	Union	X	2
8	45-4-2-N-0	Elbow	X	2
9	A729-15	Tube (Ref, to manifold pressure gage; see Figure 96-37)		
10	A729-6	Tube (7-hole console)	X	1
	A729-13	Tube (9-hole console)	X	1
11	A602-1	Rate-of-Climb Indicator (Ref)		
12	A729-26	Tube	X	1
13	60-4-2-N-0	Tee	X	6
14	A729-25	Tube	X	1
15	MS3367-5-9	Ty-Rap (or MS3367-4-9)	X	A/R
16	A729-11	Tube	X	1
17	A613	Altimeter (Ref, see Figure 95-1)		
18	A602-2	Rate-of-Climb Indicator (Ref, IVSI; optional)		
19	MS28778-6	Packing (o-ring)	X	1
20	A763-1	Adapter	X	1
21	70-4-N-0	Tee (7-hole console)	X	1
	60-4-2-N-0	Tee (10-hole console)	X	1
22	A729-18	Tube	X	1
23	A729-14	Tube (pitot)	X	1
24	25-4-2-N-0	Fitting	X	2
25	PI0808S	Plug	X	2
26	MS21042L08	Nut	X	6
27	NAS1149FN816P	Washer	X	6
28	C059	Wire Harness (Ref)		
29	MS21919WDG12	Clamp	X	6

NOTES * Seven-hole console installation shown.

Continues

FIGURE AND INDEX NUMBER	PART NUMBER	DESCRIPTION	PARTS AVAIL	QTY PER ASSY
PITOT/STATIC LINES INSTALLATION* (Cont'd)				
95-49-30	C293	Keel Panel – (Ref, LH)		
31	MS27039C0806	Screw	X	5
32	MS21919WDG9	Clamp	X	6
33	MS27039C0806	Screw	X	5
34	MS3367-4-9	Ty-Rap	X	12
35	C731-1	Fuel Vent Line (Ref, see also Figure 28-1)		
36	MS21083-N5	Nut	X	1
37	AN960PD516L	Washer	X	1
38	A246-3	Spacer	X	1
39	A262-1	Fitting – Pitot Tube	X	1
40	A596-1	Elbow	X	1
41	NAS557-4A	Grommet	X	1
42	A729-25	Tube (Use with B240-1 Blind Encoder. See Figure 97-23.)	X	1
43	A729-12	Tube (static)	X	2
44	10-4-6-N-0	Fitting	X	2
45	45-6-6-N-0	Elbow	X	2
46	A729-32	Tube	X	2
47	50-6-N-0	Elbow	X	2
48	MS3367-5-9	Ty-Rap	X	2
49	NAS557-22A	Grommet	X	2
50	C262-2	Fitting (install using items 51 and 52)	X	1
51	B270-1	Sealant (2-oz tube)	X	A/R
52	NAS1097AD3	Rivet	X	2
53	MS3367-7-9	Ty-Rap (use [2] of item 34 as “stand off”)	X	2
54	C006	Main Rotor Gearbox (Ref)		
55	2813	Bushing (Ref, see Figure 67-57)		
56	C559-6	Brace (Ref, see Figure 67-57)		
57	45-4-2-N-0	Elbow (Use with B240-1 Blind Encoder. See Figure 97-23.)	X	1

NOTES * Seven-hole console installation shown.

Intentionally Blank

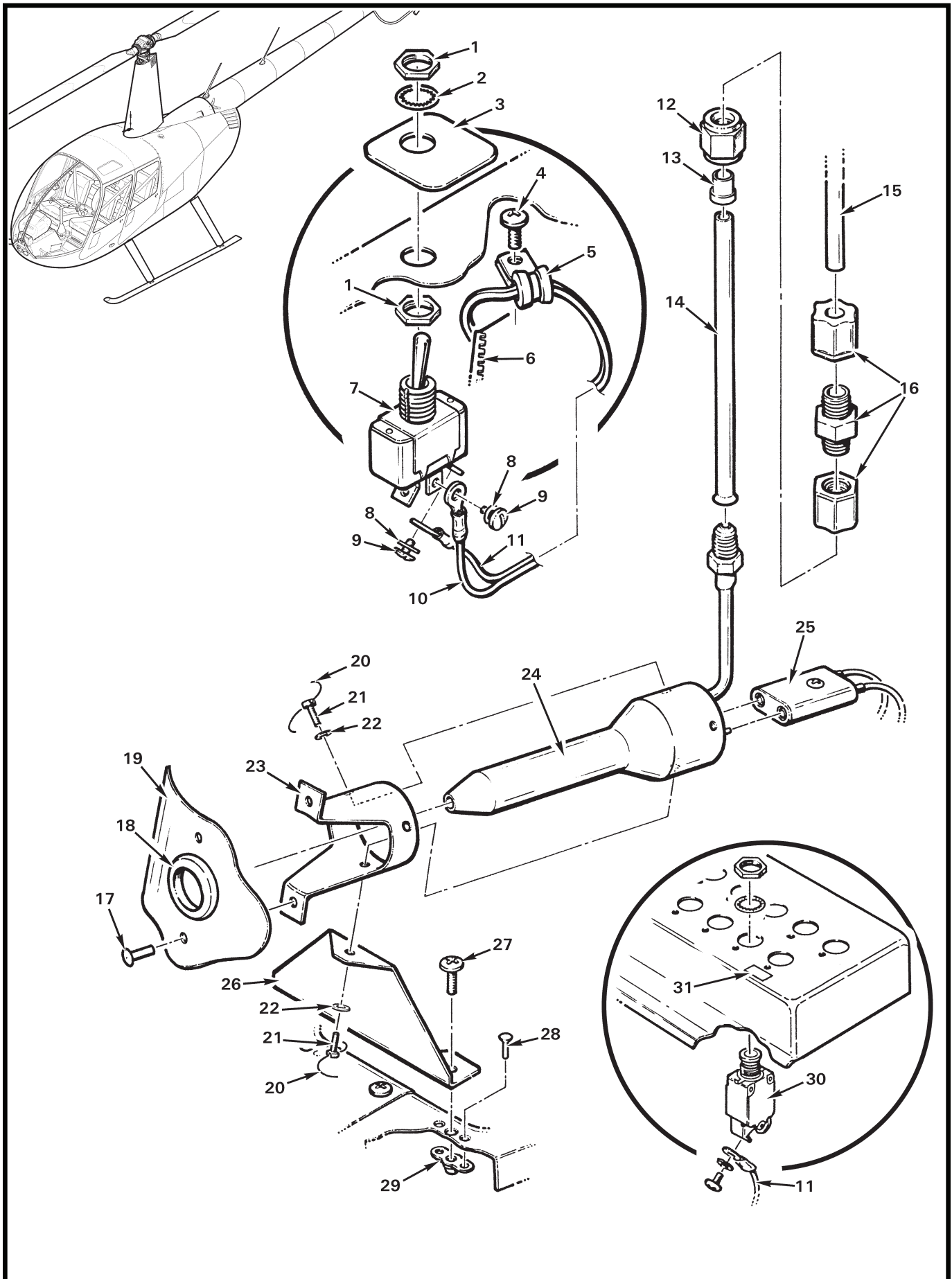

FIGURE AND INDEX NUMBER	PART NUMBER	DESCRIPTION	PARTS AVAIL	QTY PER ASSY
HEATED PITOT INSTALLATION				
95-53-1	—	Nut	O	2
2	—	Lockwasher	O	1
3	D339-3	Nameplate	X	1
4	MS27039C0806	Screw (Ref)	X	1
5	MS21919WDG2	Clamp	X	1
6	MS21266-1N	Grommet (install using B270-8qt adhesive)	X	A/R
	B270-8qt	Adhesive (one-quart can)	X	A/R
7	B300-4	Switch (Incl items 1, 2, 8, and 9)	X	1
8	—	Washer	O	2
9	—	Screw	O	2
10	-709	Wire (Ref)		
11	-710	Wire (Ref)		
12	AN818-4D	Nut	X	1
13	MS20819-4D	Sleeve	X	1
14	D339-4	Tube	X	1
15	A729-14	Tube (Ref; see also Figure 95-27)		
16	15-4-N-0	Union	X	1
17	MS20470AD4	Rivet	X	2
18	MS35489-17X	Grommet	X	1
19	C261-2	Skin (Mast Fairing; Ref)		
20	MS20995C20	0.020 in .dia. Safety Wire	X	A/R
21	AN502-6-6	Screw	X	3
22	NAS620-6	Washer	X	3
23	D339-1	Mount	X	1
24	D340-1	Pitot Tube Assembly (14-volt ships; includes item 25)	X	1
	D340-2	Pitot Tube Assembly (28-volt ships; includes item 25)	X	1
25	—	Connector (with sockets)	O	1
26	D339-2	Brace	X	1
27	MS27039C0806	Screw	X	2
28	MS20426AD3	Rivet (flush head)	X	2
29	MS21069L08	Nutplate	X	2
30	B297-10	Circuit Breaker (10-amp)	X	1
31	C654-26	Decal – "Pitot Heat" (for earlier R44s)	X	1
NOTES				

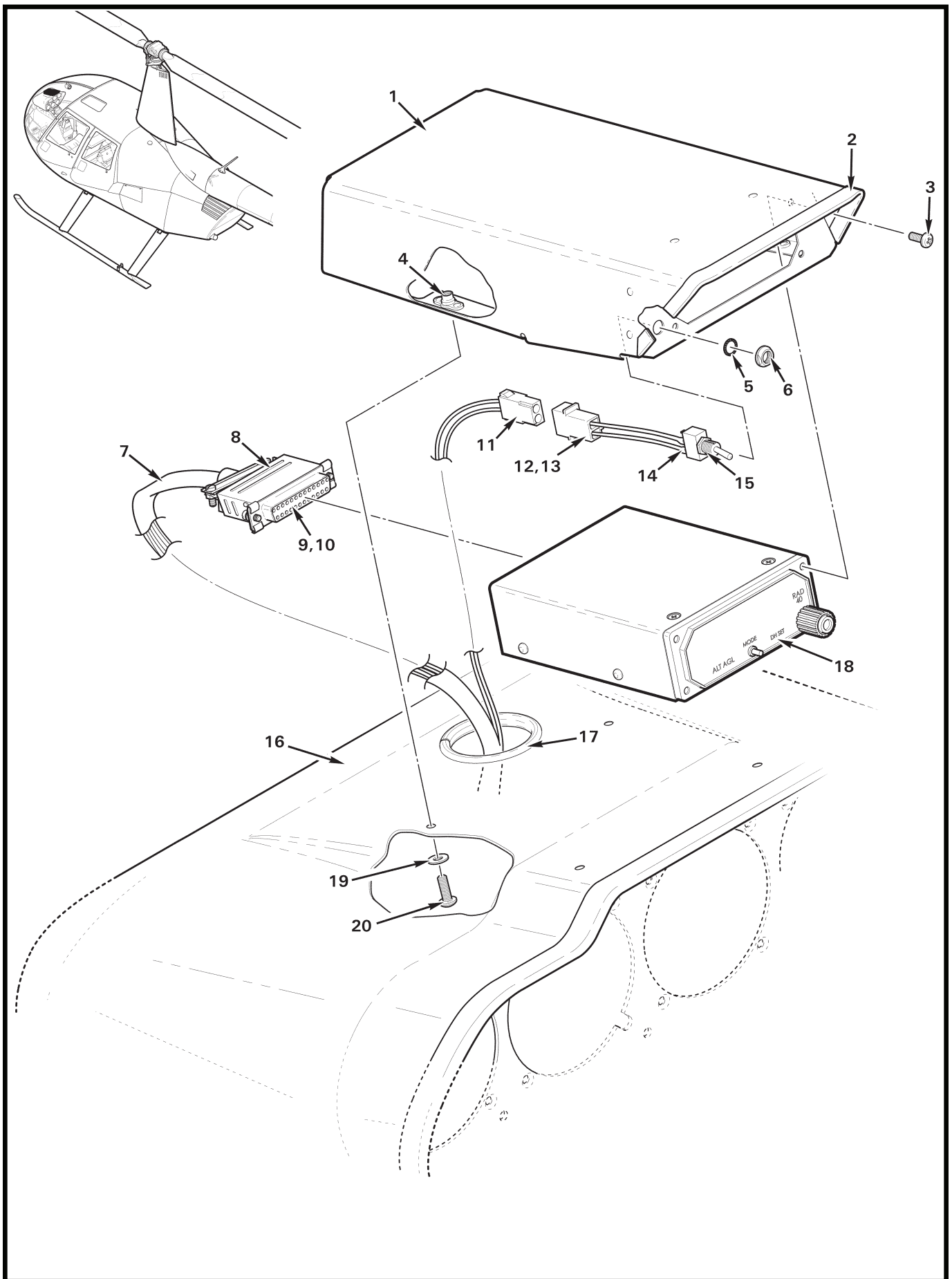

FIGURE AND INDEX NUMBER	PART NUMBER	DESCRIPTION	PARTS AVAIL	QTY PER ASSY
RADAR ALTIMETER INDICATOR INSTALLATION				
95-55-1	B560-1	Enclosure Assembly (Incl items 2 and 4)	X	1
2	A226-15	Trim	X	A/R
3	9-2804-068-10*	Screw	O	4
4	MS21069L08	Nutplate	X	4
5	B227-3	Lockwasher	X	1
6	B227-4	Dress Nut	X	1
7	B266-8	Sleeving	X	A/R
8	9-2190-188-20**	Hood	O	1
9	9-2190-188-10**	Connector	O	1
10	B158-2	Heat Shrink (around wires; not shown)	X	A/R
11	B263-13	Housing	X	1
	B263-2	Socket	X	2
12	B049-9	Wire Harness Assembly (Incl items 13 thru 15)	X	1
13	B263-12	Housing	X	1
	B263-1	Pin	X	2
14	B158-1	Heat Shrink	X	A/R
15	B300-1	Switch Assembly (Incl items 5 and 6)	X	1
16	B051-1	Console Assembly (Ref)		
17	NAS557-24A	Grommet	X	1
18	B422-1	Indicator Assembly (Incl item 3)	X	1
19	NAS1149FN832P	Washer	X	4
20	MS27039C0807	Screw	X	4

NOTES * Above console location.
 ** Free-Flight Systems part no.

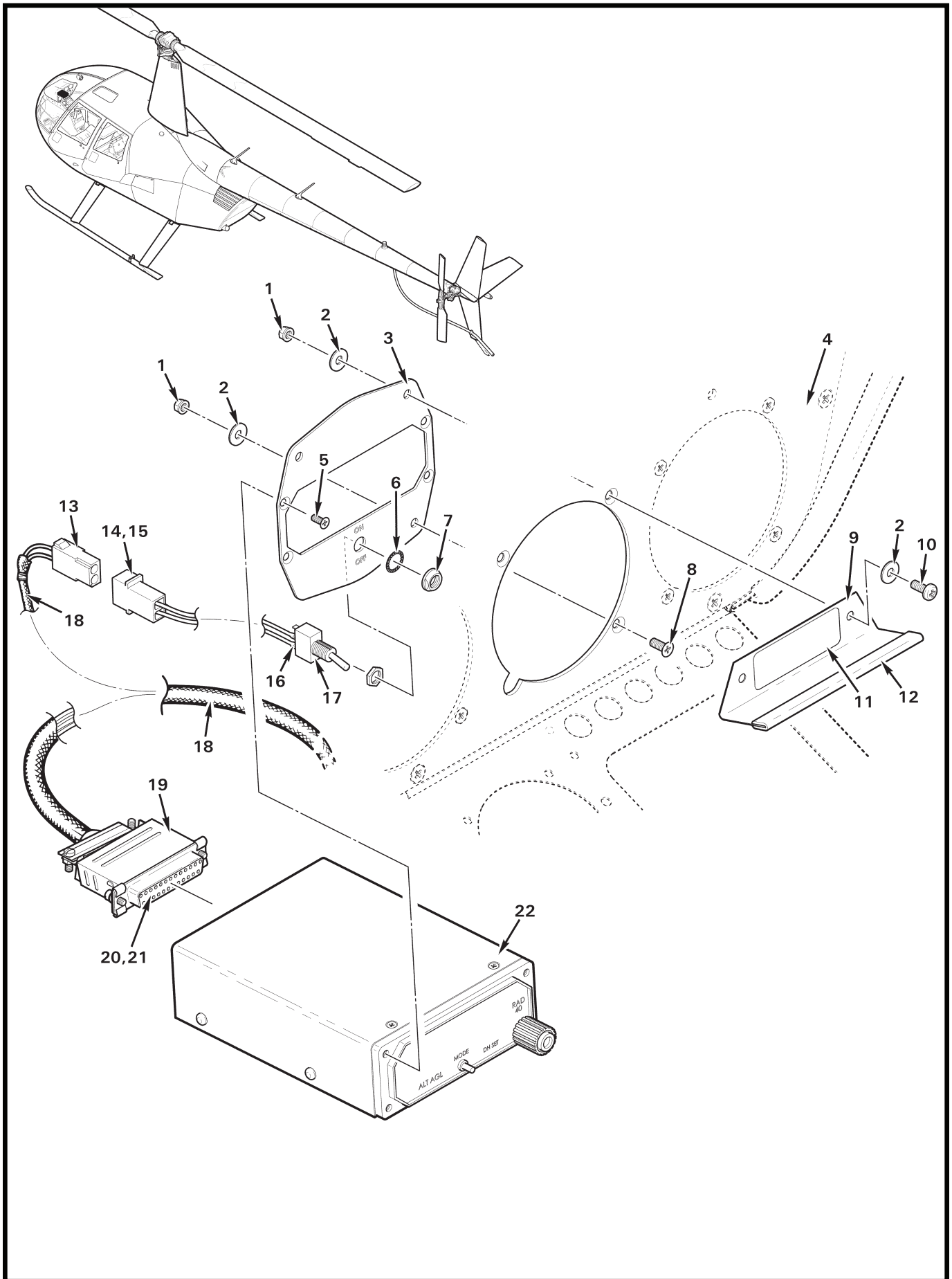

FIGURE AND INDEX NUMBER	PART NUMBER	DESCRIPTION	PARTS AVAIL	QTY PER ASSY
RADAR ALTIMETER INDICATOR INSTALLATION				
95-57-1	MS21042L06	Nut	X	3
2	NAS1149FN632P	Washer	X	5
3	A590-4	Plate	X	1
4	B051	Console Assembly (Ref)		
5	9-2804-068-10*	Screw	O	4
6	B227-3	Lockwasher	X	1
7	B227-4	Dress Nut	X	1
8	MS24693-S26	Screw	X	1
9	B421-1	Visor Assembly (Incl items 11 and 12)	X	1
10	MS35206-229	Screw	X	2
11	C654-46	Decal – Caution (altimeter instructions)	X	1
12	A226-11	Trim	X	A/R
13	B263-13	Housing	X	1
	B263-2	Socket	X	2
14	B049-9	Wire Harness Assembly (Incl items 15 thru 17)	X	1
15	B263-12	Housing	X	1
	B263-1	Pin	X	2
16	B158-1	Heat Shrink	X	A/R
17	B300-1	Switch Assembly (Incl items 6 and 7)	X	1
18	B266-8	Sleeving	X	A/R
19	9-2190-188-20**	Hood	O	1
20	9-2190-188-10**	Connector	O	1
21	B158-2	Heat Shrink (not shown)	X	A/R
22	B422-1	Indicator Assembly (Incl item 5)	X	1

NOTES * Console location.
 ** FreeFlight Systems part no.

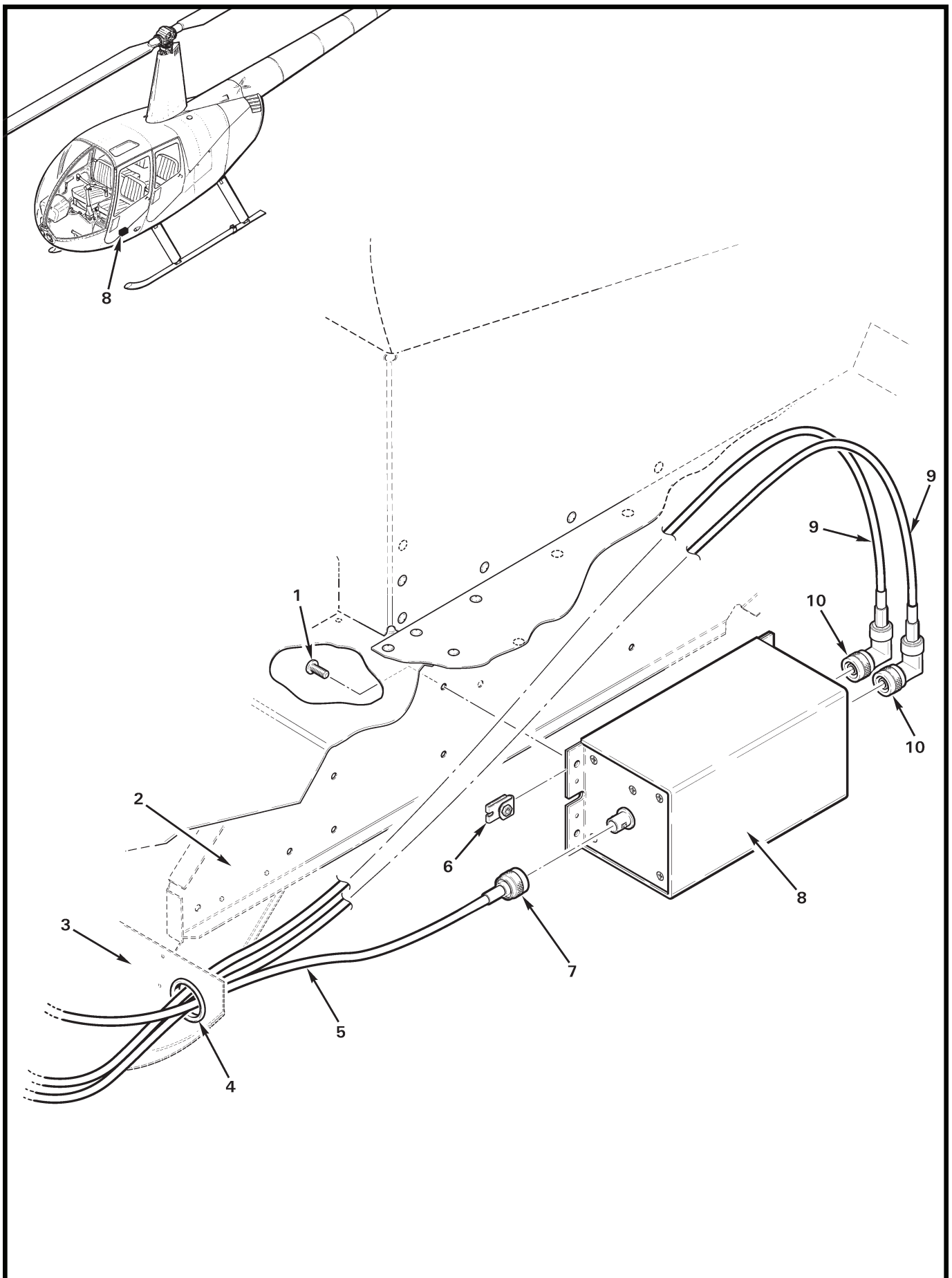

FIGURE AND INDEX NUMBER	PART NUMBER	DESCRIPTION	PARTS AVAIL	QTY PER ASSY
RADAR ALTIMETER INSTALLATION				
95-59-1	MS20739C0807	Screw	X	4
2	C531	Support (Ref)		
3	D230	Bulkhead (Ref)		
4	NAS557-14A	Grommet	X	1
5	—	Cable (wire no. 1329; to indicator)	O	1
6	B162-3	Clipnut	X	4
7	9-2122-102-00*	Connector (BNC)	O	1
8	1901-3500-00*	Radar Altimeter (Model no. TRA-3500)	O	1
9	—	Cable (to antennas; supplied with item 8)	O	2
10	—	Connector (BNC)	O	2

NOTES * FreeFlight Systems part no.

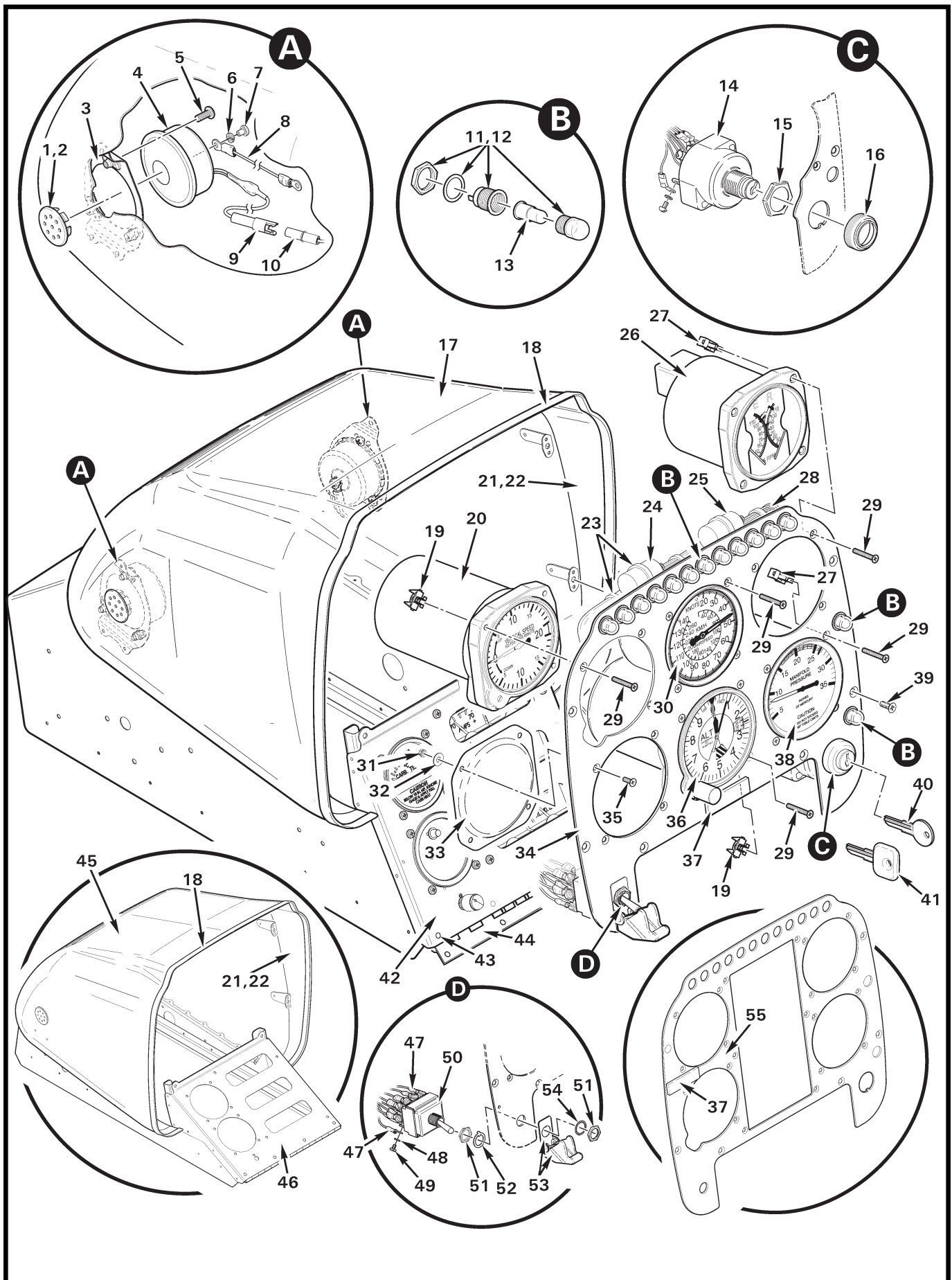

FIGURE AND INDEX NUMBER	PART NUMBER	DESCRIPTION	PARTS AVAIL	QTY PER ASSY
SIX-INSTRUMENT CONSOLE ASSEMBLY				
95-61-1	9688K643	Hole Plug (install using item 2)	X	2
2	B270-18	Adhesive	X	A/R
3	C479-1	Mount Assembly (Ref)		
4	B320-1	Horn Assembly (RH and LH, 14-volt; includes items 6 thru 9)	X	2
	B320-3	Horn Assembly (RH and LH, 28-volt; includes items 6 thru 9)	X	2
5	MS27039C0806	Screw	X	6
6	B332-42	Lockwasher	X	1
7	MS35206-241	Screw	X	1
8	B320-79	Wire (to ground)	X	1
9	B263-10	Housing	X	1
	B263-1	Pin	X	1
10	B263-11	Housing (Ref)		
	B263-2	Socket (Ref)		
11	B198-1	Light (amber; includes washer, nut, and amber lens as shown)	X	12
12	B198-2	Light (red; includes washer, nut, and red lens as shown)	X	2
13	B196-1	Lamp (14-volt)	X	1
	B196-21	Lamp (28-volt)	X	1
14	A661-1	Switch – Ignition (Incl items 15, 16, and two keys)	X	1
15	—	Nut	O	1
16	—	Nut	O	1
17	G051-18	Shell Assembly (“High”; includes items 1, 2, 18, 21, 22, and 42)	X	1
18	A226-11	Trim	X	A/R
19	MS33737-13C	Nut – Instrument	X	6
20	A602-1	Rate-of-Climb Indicator	X	1
21	G051-13	Visor Liner (install using item 22)	X	A/R
22	B270-8QT	Adhesive	X	A/R
23	MS3367-5-9	Ty-Rap	X	A/R
24	A655-1	Time Delay – Low Fuel Warning	X	1
25	B280-4	Relay Assembly (governor off lamp)	X	1
26	C792-4	Engine/Rotor Tachometer (14-volt, without alert; superseded by C792-5)	O	1
	C792-5	Engine/Rotor Tachometer (14/28-volt, with alert; not shown)	X	1
	B792-2*	Harness Assembly – Dual Tach (not shown)	X	1
27	MS33737-15C	Nut – Instrument	X	12

NOTES * Required to connect C792-5 tachometer to airframe wiring on R44 ship S/N 2624 and prior, R44 II S/N 10001 thru 14411, except 14364, and R44 Cadet S/N 30001 thru 30070, except 30061.

Continues

FIGURE AND INDEX NUMBER	PART NUMBER	DESCRIPTION	PARTS AVAIL	QTY PER ASSY
SIX-INSTRUMENT CONSOLE ASSEMBLY (Cont'd)				
95-61-28	D716-010	Harness Assembly – Console (Ref; includes items 14, 23 thru 25, 49, and 52)	X	1
29	MS24693-S32	Screw	X	18
30	C599-1	Airspeed Indicator (130 knot VNE, KM/H)	X	1
	C599-7*	Airspeed Indicator (120 knot VNE, MPH)	X	1
	C599-8*	Airspeed Indicator (120 knot VNE, KM/H; superseded by C599-7)	O	1
31	MS21042L06	Nut	X	4
32	NAS1149FN616P	Washer	X	4
33	B190-6	Cover	X	1
34	G055-10	Face (standard)	X	1
35	MS24693-S27	Screw	X	4
36	A613-1	Altimeter	X	1
37	A743-1	Call Letters Plate (please specify call letters)	X	1
38	A600-4	Manifold Pressure Gage	X	1
	A600-7**	Manifold Pressure Gage	X	1
39	MS24694-S4	Screw	X	6
40	R8096	Key – Duplicate (specify ship S/N and “PK” number when ordering)	X	1
41	D768-2	Key (blank; black plastic-coated “R44” logo)	X	1
42	G054-16	Face Assembly (Incl items 43 and 44)	X	1
43	MS20426AD3	Rivet	X	4
44	A356-2	Hinge (install using item 43)	X	1
45	G051-12	Shell Assembly (“Low”, for earlier R44s. Includes items 1, 2, 18, 21, 22, and 46.)	O	1
46	G054-17	Face Assembly (Incl items 43 and 44)	O	1
47	B260-2	Terminal	X	16
48	—	Washer (Ref)		
49	—	Screw (Ref)		
50	MS25068-23	Switch – Clutch (Incl items 48, 49, 51, 52, and 54)	X	1
51	—	Nut	O	2
52	—	Keywasher	O	1
53	MS25224-1	Guard	X	1
54	—	Lockwasher	O	1
55	G055-11	Face (optional)	X	1

NOTES * Ship S/N 30001 and subsequent.
 ** Ship S/N 30009 and subsequent.

Intentionally Blank

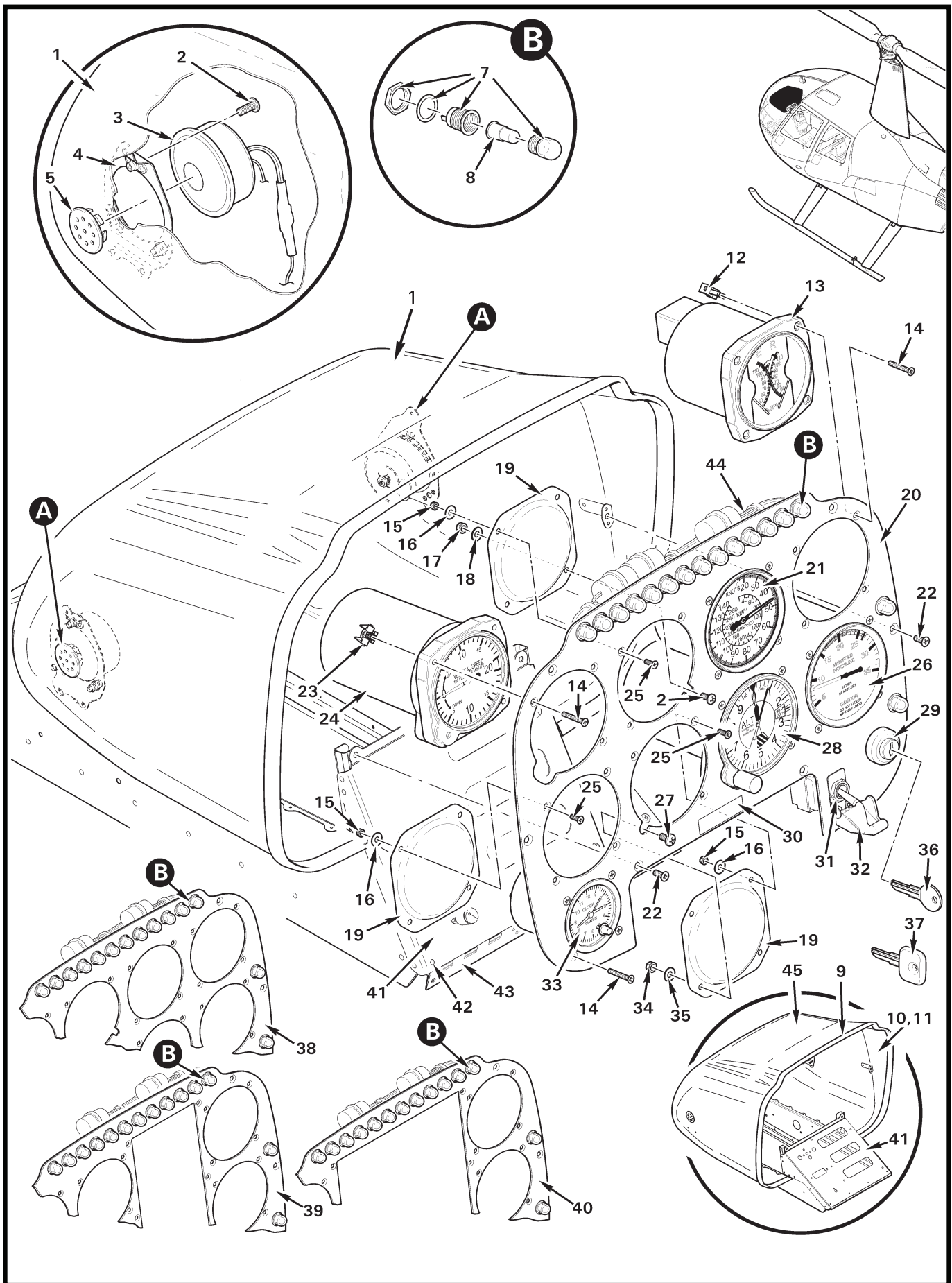

FIGURE AND INDEX NUMBER	PART NUMBER	DESCRIPTION	PARTS AVAIL	QTY PER ASSY
		EIGHT-INSTRUMENT CONSOLE ASSEMBLY		
95-65-1	G051-3*	Shell Assembly ("High"; includes items 4 thru 6, 9 thru 11, and 41 thru 43.)	X	1
	G051-4**	Shell Assembly ("High"; includes items 4 thru 6, 9 thru 11, and 41 thru 43.)	X	1
	G051-16**	Shell Assembly ("High"; Clipper II, includes items 4 thru 6, 9 thru 11, and 41 thru 43.)	X	1
2	MS27039C0806	Screw	X	7
3	B320-1	Horn Assembly (14-volt)	X	2
	B320-3	Horn Assembly (28-volt)	X	2
4	C479-1	Mount Assembly	X	2
5	9688K643	Plug (install using item 6)	X	2
6	B270-18	Adhesive	X	A/R
7	B198-1	Light – Caution (Amber; clutch actuator, main rotor temperature, main rotor chip, carbon monoxide, starter, tail rotor chip, low fuel, low rotor rpm, alternator, fuel filter***, aux fuel pump***, gov off, throttle, and brake. Order item 8 when replacing lamp.)	X	A/R
	B198-2	Light – Warning (Red; engine fire, oil pressure. Order item 8 when replacing lamp.)	X	2
8	B196-21	Lamp (28-volt)	X	16
	B196-1	Lamp (14-volt)	X	14
9	A226-11	Trim	X	A/R
10	G051-10	Visor Liner (install using item 11)	X	1
11	B270-8qt	Adhesive	X	A/R
12	MS33737-15C	Nut	X	12
13	C792-4	Engine/Rotor Tachometer	X	1
	R9602	Engine/Rotor Tachometer (overhaul-exchange)	X	1
14	MS24693-S32	Screw	X	22
15	MS21042L08	Nut	X	10
16	NAS1149FN616P	Washer	X	10
17	MS21042L08	Nut	X	1
18	NAS1149FN816P	Washer	X	1
19	B190-6	Cover	X	3
20	G055-5**	Face	X	1
21	C599-1	Airspeed Indicator (130 knot VNE, KM/H)	X	1
	C599-7	Airspeed Indicator (120 knot VNE, MPH; R44 Cadet)	X	1
	C599-8	Airspeed Indicator (120 knot VNE, KM/H; R44 Cadet)	X	1

NOTES * Ship S/N 0001 thru 9999.
 ** Ship S/N 10001 and subsequent.
 *** If installed.

Continues

FIGURE AND INDEX NUMBER	PART NUMBER	DESCRIPTION	PARTS AVAIL	QTY PER ASSY
EIGHT-INSTRUMENT CONSOLE ASSEMBLY (Cont'd)				
95-65-22	MS24694-S4	Screw	X	6
23	MS33737-13C	Nut	X	6
24	A602-1	Rate-of-Climb Indicator (VSI)	X	1
25	MS24693-S27	Screw	X	10
26	A600-4*	Manifold Pressure Gage	X	1
	A600-6**	Manifold Pressure Gage	X	1
	A600-7***	Manifold Pressure Gage	X	1
27	MS27039C1-06	Screw	X	1
28	A613-1	Altimeter (In.-Hg)	X	1
	A613-2	Altimeter (Millibar, optional)	X	1
	A613-4	Altimeter (Metric, optional)	X	1
29	A661-1	Switch – Ignition	X	1
30	A743-1	Call Letters Plate (specify call letters)	X	1
31	MS25068-23	Switch – Clutch	X	1
32	MS25224-1	Guard – Clutch Switch	X	1
33	A072-12*	Clock Assembly (14-volt)	X	1
	A072-13**	Clock Assembly (28-volt)	X	1
34	MS21042L3	Nut	X	1
35	NAS1149F0332P	Washer	X	1
36	R8069	Key – Duplicate (specify ship S/N and “PK” number when ordering)	X	1
37	D768-2	Key (blank; black plastic-coated, “R44” logo)	X	1
38	G055-4*	Face	X	1
39	G055-1*	Face	X	1
	G055-2**	Face (not shown)	X	1
40	G055-7*	Face	X	1
	G055-8**	Face (not shown).	X	1
41	G054	Face Assembly (Ref, see Figure 95-47 or 95-51)		
42	MS20426AD3	Rivet	X	4
43	A356-2	Hinge	X	1
44	D716-010	Harness Assembly – Console (Ref)		

NOTES * Ship S/N 0001 thru 9999.
 ** Ship S/N 10001 and subsequent.
 *** Ship S/N 30001 and subsequent.

Continues

FIGURE AND INDEX NUMBER	PART NUMBER	DESCRIPTION	PARTS AVAIL	QTY PER ASSY
95-65-45	G051-7*	EIGHT-INSTRUMENT CONSOLE ASSEMBLY (Cont'd) Shell Assembly ("Low"; includes items 4 thru 6, 9 thru 11, and 41 thru 43. Restricted availability. Contact RHC Customer Service before ordering.)	X	1
	G051-8**	Shell Assembly ("Low"; includes items 4 thru 6, 9 thru 11, and 41 thru 43. Restricted availability. Contact RHC Customer Service before ordering.)	X	1
	G051-17**	Shell Assembly ("Low", Clipper II. Includes items 4 thru 6, 9 thru 11, and 41 thru 43. Restricted availability. Contact RHC Customer Service before ordering.)	X	1
<p>NOTES * Ship S/N 0001 thru 9999. ** Ship S/N 10001 and subsequent.</p>				

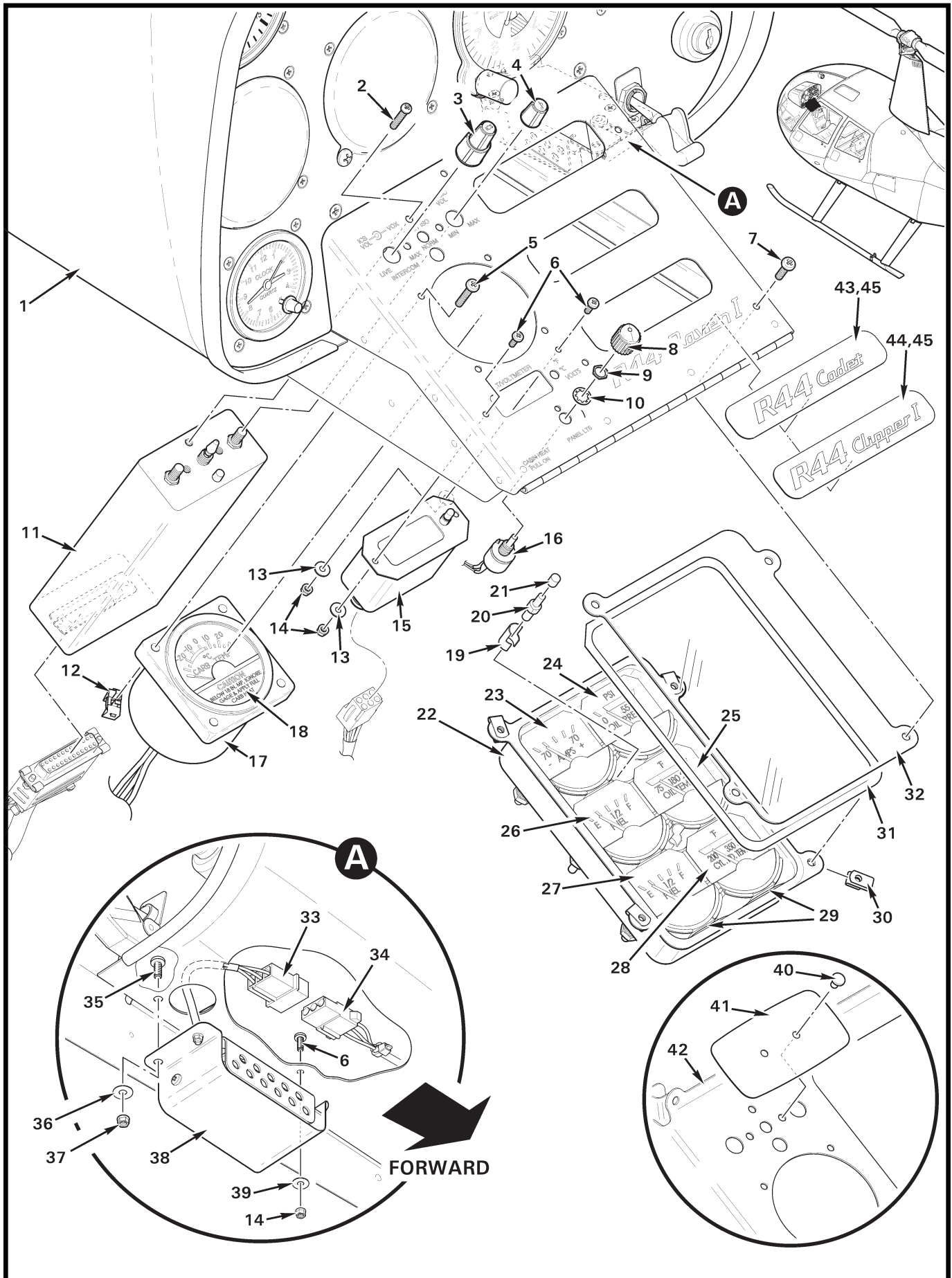

FIGURE AND INDEX NUMBER	PART NUMBER	DESCRIPTION	PARTS AVAIL	QTY PER ASSY
		INSTRUMENT CONSOLE ASSEMBLY – LOWER PANEL (R44)		
95-69-1	G051-7	Shell Assembly (Ref)		
	G051-12	Shell Assembly (Ref, not shown. Six-instrument console; item 39 location does not apply.)		
2	—	Screw	O	3
3	—	Knob	O	1
4	—	Knob	O	1
5	MS35206-232	Screw	X	4
6	MS35206-214	Screw	X	3
7	MS35206-230	Screw	X	4
8	MS91528-0C1B	Knob	X	1
9	—	Nut	O	1
10	—	Lockwasher	O	1
11	B338-2	Intercom System Unit (Incl items 2 thru 4)	X	1
12	MS33737-12C	Nut – Instrument	X	4
13	NAS1149FN432P	Washer	X	2
14	MS21042L04	Nut	X	3
15	B341-1	Outside Air Temperature Gage (does not include B341-4 probe)	X	1
16	B398-1	Potentiometer (Incl items 9 and 10)	X	1
17	C604-6	Carb Air Temp Gage (Incl item 18)	X	1
18	A654-66	Decal (carb heat instructions)	X	1
19	A700-1	Barrier	X	2
20	100057017	Lamp (gray base)	X	2
21	6P47	Cap (for red lighting requirement)	X	2
	17P47	Cap (for white lighting requirement)	X	2
22	B144-3	Instrument Cluster (14-volt; includes items 19 thru 21 and 23 thru 32)	X	1
23	6246-00468	Ammeter	X	1
24	6246-00647	Oil Pressure Meter (14-volt)	X	1
25	6246-00090	Oil Temperature Meter (14-volt)	X	1
26	6246-00473	Fuel Quantity Meter (main tank, 14-volt)	X	1
27	6246-00473	Fuel Quantity Meter (aux tank, 14-volt)	X	1
28	6246-00088	Cylinder Head Temperature Meter (14-volt)	X	1
29	—	Desicant Bag (1-gram bag, Ref)	O	2
30	B162-1	Clipnut	X	4
31	0015-00723	Gasket	X	1

NOTES

Continues

FIGURE AND INDEX NUMBER	PART NUMBER	DESCRIPTION	PARTS AVAIL	QTY PER ASSY
INSTRUMENT CONSOLE ASSEMBLY – LOWER PANEL (R44; Cont’d)				
95-69-32	0003-00434	Window Crystal (clear plastic)	X	1
33	B263-14	Housing	X	1
	B263-1	Pin	X	3
34	B263-15	Housing	X	1
	B263-2	Socket	X	3
35	MS35206-228	Screw	X	1
36	NAS1149FN616P	Washer	X	1
37	MS21042L06	Nut	X	1
38	C696-1	CO Detector Assembly (includes item 33; eight-instrument console location shown)	X	1
39	NAS1149FN416P	Washer	X	1
40	SR-3535B	Rivet	X	1
41	B181-7	Cover	X	1
42	G054-6	Cluster Panel – Face Assembly (Ref)		
43	G054-23	Plate – “R44 Cadet”	X	1
44	G054-15	Plate – “R44 Clipper I”	X	1
45	A701-7	Tape (black foam, adhesive both sides)	X	A/R
NOTES				

Intentionally Blank

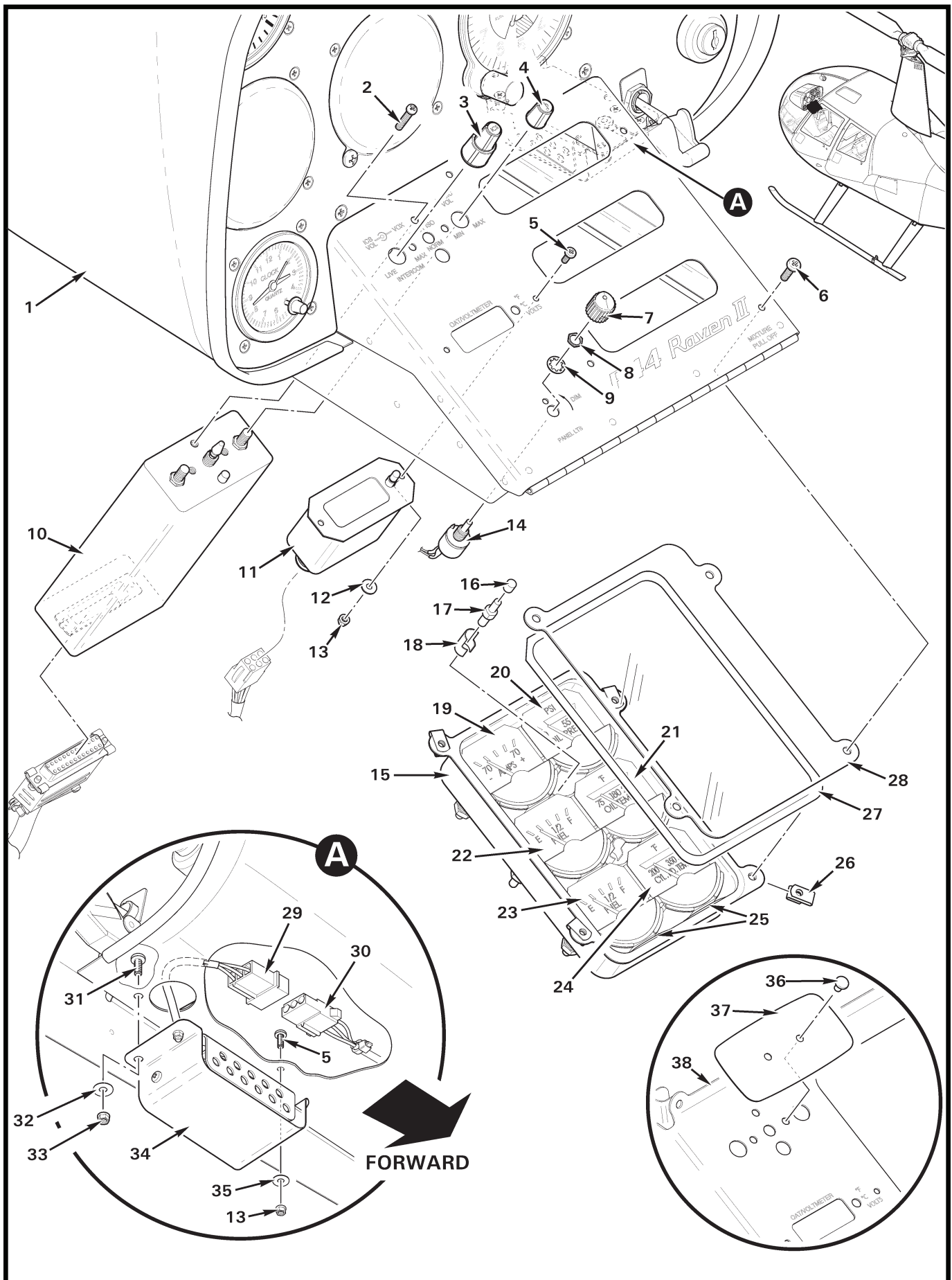

FIGURE AND INDEX NUMBER	PART NUMBER	DESCRIPTION	PARTS AVAIL	QTY PER ASSY
		INSTRUMENT CONSOLE ASSEMBLY – LOWER PANEL (R44 II)		
95-73-1	G051-8	Shell Assembly (Ref)		
2	—	Screw	O	3
3	—	Knob	O	1
4	—	Knob	O	1
5	MS35206-214	Screw	X	3
6	MS35206-230	Screw	X	4
7	MS91528-0C1B	Knob	X	1
8	—	Nut	O	1
9	—	Lockwasher	O	1
10	B338-2	Intercom System Unit (Incl items 2 thru 4)	X	1
11	B341-1	Outside Air Temperature Gage (does not include B341-4 probe)	X	1
12	NAS1149FN432P	Washer	X	2
13	MS21042L04	Nut	X	3
14	B398-1	Potentiometer (Incl items 9 and 10)	X	1
15	B144-4	Instrument Cluster (28-volt; includes items 16 thru 28)	X	1
16	6P47	Cap (for red lighting requirement)	X	2
	17P47	Cap (for white lighting requirement)	X	2
17	100057022	Lamp (28-volt, red base)	X	2
18	A700-1	Barrier	X	2
19	6246-00468	Ammeter	X	1
20	6246-00715	Oil Pressure Meter (28-volt)	X	1
21	6246-00717	Oil Temperature Meter (28-volt)	X	1
22	6246-00716	Fuel Quantity Meter (main tank, 28-volt)	X	1
23	6246-00716	Fuel Quantity Meter (aux tank, 28-volt)	X	1
24	6246-00718	Cylinder Head Temp Meter (28-volt)	X	1
25	—	Desicant Bag (1-gram bag, Ref)	O	2
26	B162-1	Clipnut	X	4
27	0015-00723	Gasket	X	1
28	0003-00434	Window Crystal (clear plastic)	X	1
29	B263-14	Housing	X	1
	B263-1	Pin	X	3
30	B263-15	Housing	X	1
	B263-2	Socket	X	3
31	MS35206-228	Screw	X	1
32	NAS1149FN616P	Washer	X	1

NOTES

Continues

FIGURE AND INDEX NUMBER	PART NUMBER	DESCRIPTION	PARTS AVAIL	QTY PER ASSY
INSTRUMENT CONSOLE ASSEMBLY – LOWER PANEL (R44 II; Cont’d)				
95-73-33	MS21042L06	Nut	X	1
34	C696-1	CO Detector Assembly (Incl item 29)	X	1
35	NAS1149FN416P	Washer	X	1
36	SR-3535B	Rivet	X	1
37	B181-7	Cover	X	1
38	G054-7	Cluster Panel – Face Assembly (Ref)		

NOTES

Intentionally Blank

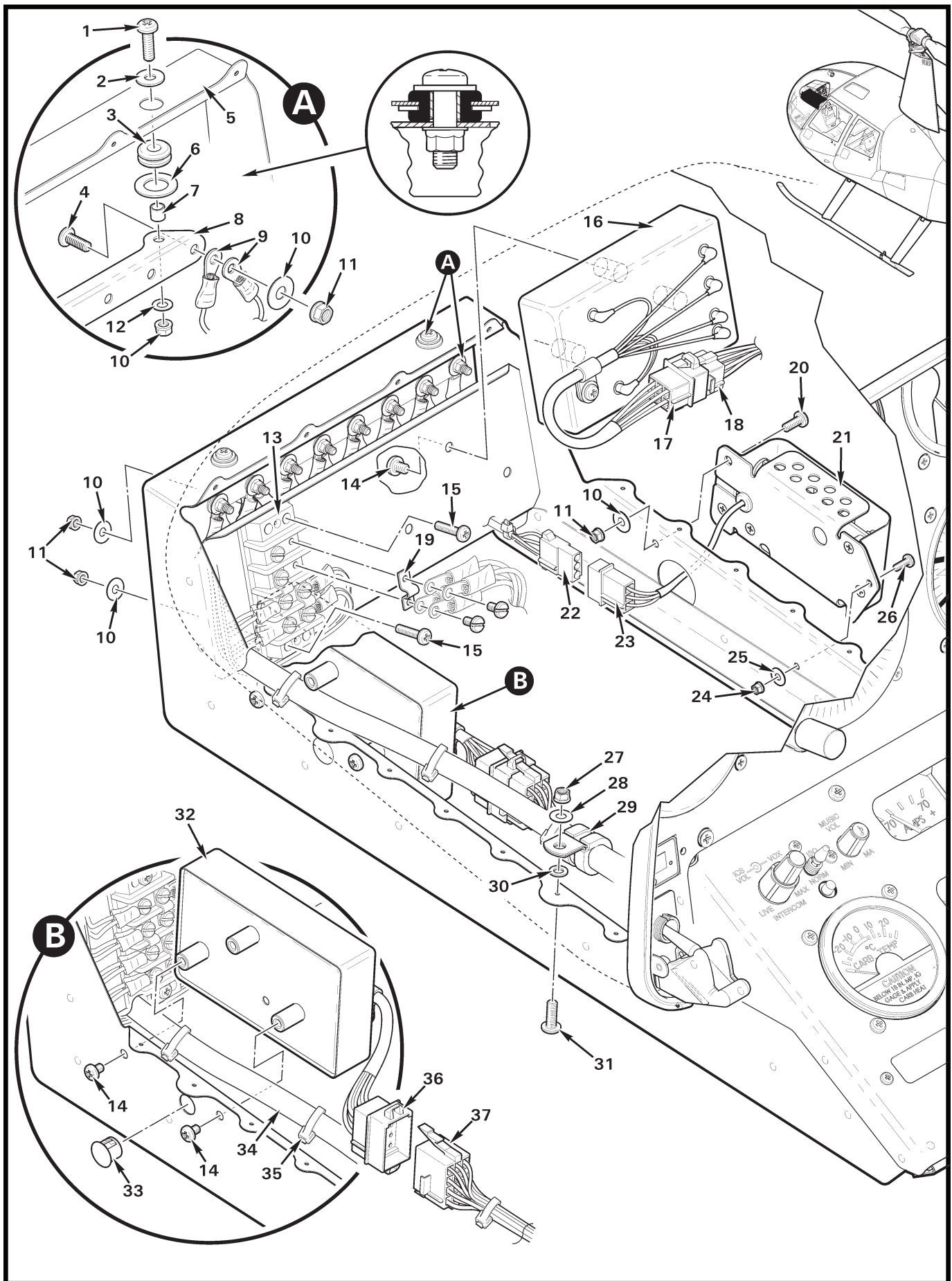

FIGURE AND INDEX NUMBER	PART NUMBER	DESCRIPTION	PARTS AVAIL	QTY PER ASSY
		SIX-INSTRUMENT CONSOLE ASSEMBLY – COMPONENTS		
95-77-1	MS35206-230	Screw	X	2
2	NAS1149FN632P	Washer	X	2
3	MS35489-4	Grommet	X	2
4	B567-25	Screw	X	8
5	G051-12	Shell Assembly – Upper Console (Ref)		
6	NAS1149F0532P	Washer (install in grommet groove; see detail showing parts assembled)	X	2
7	C130-59	Spacer (install in grommet bore; see detail showing parts assembled)	X	2
8	A448-18	Bus Bar	X	1
9	B260-2	Terminal	X	A/R
10	NAS1149FN616P	Washer	X	11
11	MS21042L06	Nut	X	13
12	NAS620-6L	Washer	X	2
13	38TB04	Terminal Block	X	1
14	MS21919WDG7	Screw	X	2
15	MS35206-241	Screw	X	5
16	B395-1	Dimmer Assembly (Incl item 17)	X	1
17	B263-18	Housing	X	1
	B263-1	Pin	X	6
18	B263-19	Housing	X	1
	B263-2	Socket	X	6
19	601985-2	Jumper Tab (or J601)	X	3
20	MS35206-228	Screw	X	1
21	C696-1	Carbon Monoxide Assembly (includes item 23 and wires)	X	1
22	B263-15	Housing	X	1
	B263-2	Socket	X	3
23	B263-14	Housing	X	1
	B263-1	Pin	X	3
24	MS21042L04	Nut	X	1
25	NAS1149FN416P	Washer	X	1
26	MS35206-214	Screw	X	1
27	MS21042L08	Nut	X	1
28	NAS1149FN816P	Washer	X	1
29	MS21919WDG7	Clamp	X	1

NOTES

Continues

FIGURE AND INDEX NUMBER	PART NUMBER	DESCRIPTION	PARTS AVAIL	QTY PER ASSY
SIX-INSTRUMENT CONSOLE ASSEMBLY – COMPONENTS (Cont'd)				
95-77-30	NAS620-8	Washer	X	1
31	MS27039C0807	Screw	X	1
32	A569-6	Low RPM Warning Unit (Incl item 36)	X	1
33	2633	Hole Plug	X	1
34	D716	Harness Assembly (Ref)		
35	MS3367-5-9	Ty-Rap	X	A/R
36	B263-22	Housing	X	1
	B263-1	Pin	X	11
37	B263-23	Housing	X	1
	B263-2	Socket	X	11

NOTES

Intentionally Blank

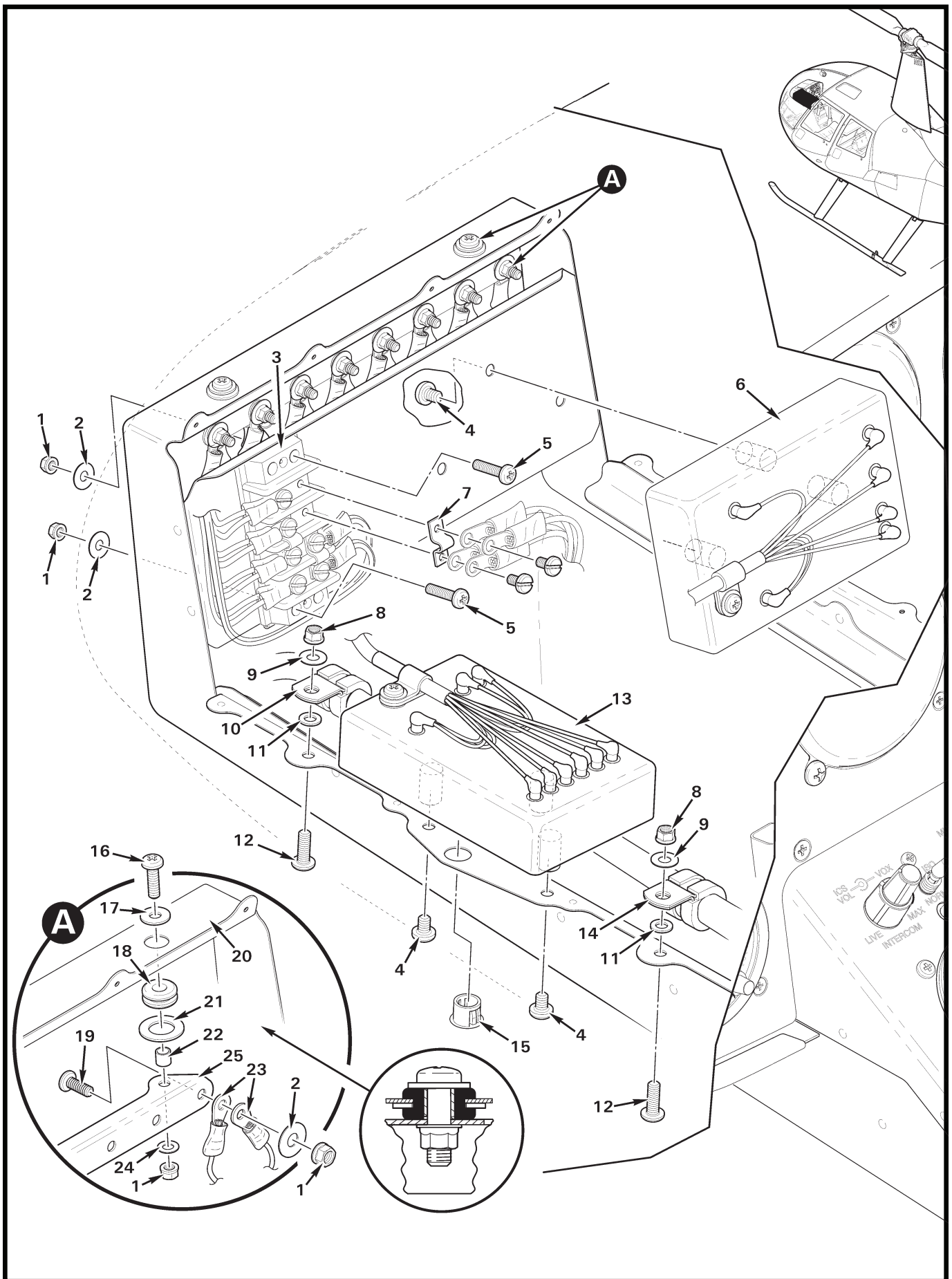

FIGURE AND INDEX NUMBER	PART NUMBER	DESCRIPTION	PARTS AVAIL	QTY PER ASSY
EIGHT-INSTRUMENT CONSOLE ASSEMBLY – COMPONENTS (R44)				
95-81-1	MS21042L06	Nut	X	12
2	NAS1149FN616P	Washer	X	10
3	601716-4	Terminal Block	X	1
4	MS35206-241	Screw	X	5
5	MS35206-231	Screw	X	2
6	B395-1	Dimmer Assembly (includes connector and wires)	X	1
7	601985-2	Jumper Tab	X	3
8	MS21042L08	Nut	X	2
9	NAS1149FN816P	Washer	X	2
10	MS21919WDG6	Clamp	X	1
11	NAS620-8	Washer	X	2
12	MS27039C0807	Screw	X	2
13	A569-6	Low RPM Warning Unit (includes connector and wires)	X	1
14	MS21919WDG7	Clamp	X	1
15	2633	Hole Plug	X	1
16	MS35206-230	Screw	X	2
17	NAS1149FN632P	Washer	X	2
18	MS35489-4	Grommet	X	2
19	B567-25	Screw	X	8
20	G051-7	Shell Assembly – Upper Console (Ref)		
21	NAS1149F0532P	Washer (install in grommet groove; see detail showing parts assembled)	X	2
22	C130-59	Spacer (install in grommet bore; see detail showing parts assembled)	X	2
23	B260-2	Terminal	X	A/R
24	NAS620-6L	Washer	X	2
25	A448-18	Bus Bar (8-hole)	X	1
NOTES				

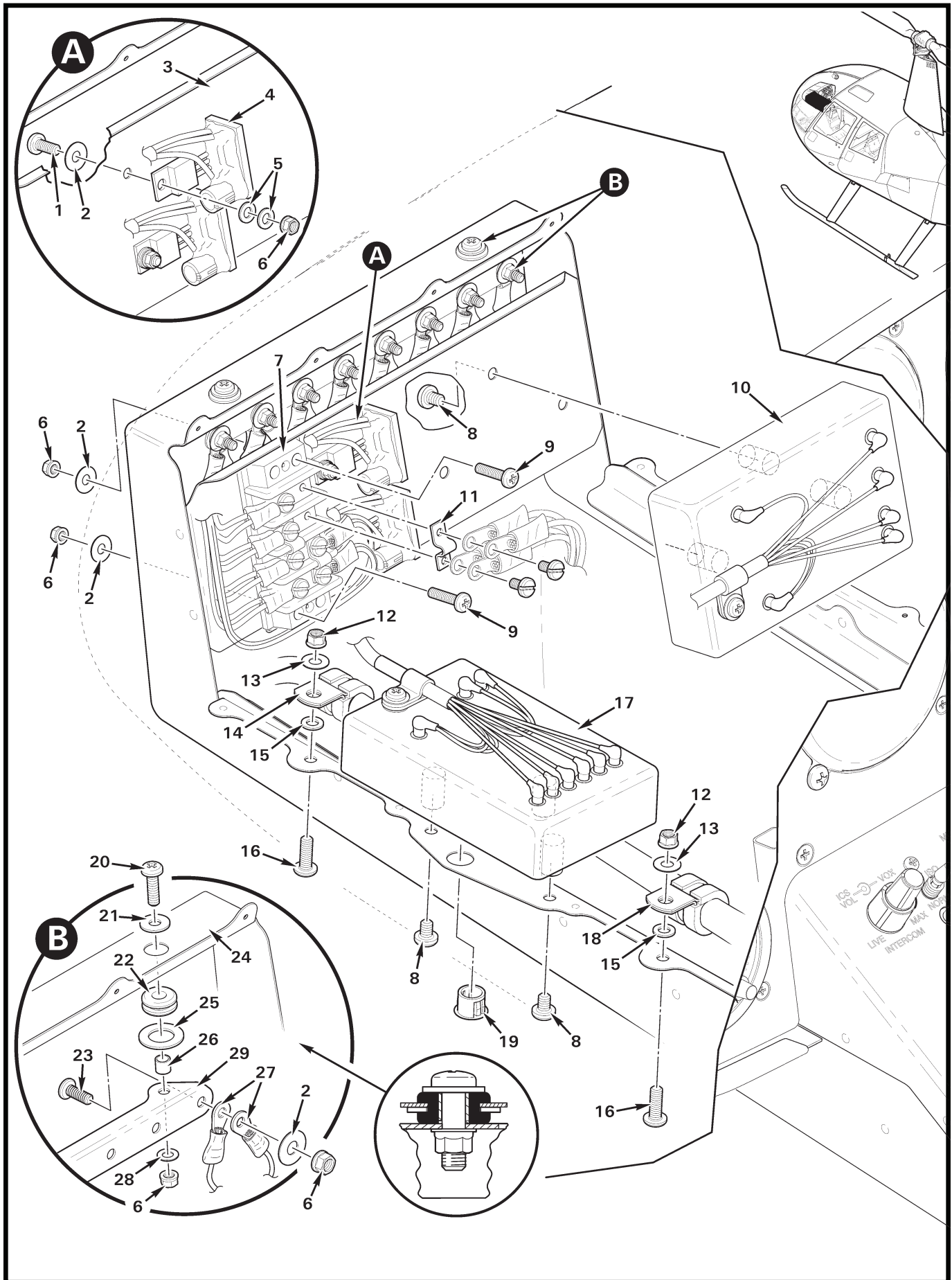

FIGURE AND INDEX NUMBER	PART NUMBER	DESCRIPTION	PARTS AVAIL	QTY PER ASSY
		EIGHT-INSTRUMENT CONSOLE ASSEMBLY – COMPONENTS (R44 II)		
95-83-1	MS35206-228	Screw	X	2
2	NAS1149FN616P	Washer	X	12
3	A365-3	Panel (Ref)		
4	D359-1	Regulator (28V to 14V)	X	2
5	NAS620-6	Washer	X	4
6	MS21042L06	Nut	X	14
7	601716-4	Terminal Block	X	1
8	MS35206-241	Screw	X	5
9	MS35206-231	Screw	X	2
10	B395-1	Dimmer Assembly (includes connector and wires)	X	1
11	601985-2	Jumper Tab	X	3
12	MS21042L08	Nut	X	2
13	NAS1149FN816P	Washer	X	2
14	MS21919WDG6	Clamp	X	1
15	NAS620-8	Washer	X	2
16	MS27039C0807	Screw	X	2
17	A569-9	Low RPM Warning Unit (includes connector and wires)	X	1
18	MS21919WDG7	Clamp	X	1
19	2633	Hole Plug	X	1
20	MS35206-230	Screw	X	2
21	NAS1149FN632P	Washer	X	2
22	MS35489-4	Grommet	X	2
23	B567-25	Screw	X	8
24	G051-8	Shell Assembly – Upper Console (Ref)		
25	NAS1149F0532P	Washer (install in grommet groove; see detail showing parts assembled)	X	2
26	C130-59	Spacer (install in grommet bore; see detail showing parts assembled)	X	2
27	B260-2	Terminal	X	A/R
28	NAS620-6L	Washer	X	2
29	A448-18	Bus Bar (8-hole)	X	1

NOTES

Intentionally Blank

CHAPTER 96**ELECTRICAL SYSTEM**

<i>Figure</i>	<i>Title</i>	<i>Page</i>
96-1	Aft Battery Installation (14V)	96.0
96-5	Aft Battery Installation (14V)	96.4
96-9	Aft Battery Installation (28V)	96.8
96-12A	Aft Battery Installation (28V)	96.12
96-13A	Aft Battery Installation (28V Lithium-Ion)	96.13
96-15	Aft Battery Installation (28V)	96.14
96-19	Nose Battery Installation (14V)	96.18
96-23	Nose Battery Installation (28V)	96.22
96-27	Nose Battery Installation (28V)	96.26
96-29	Tailcone Battery Installation	96.28
96-31	Tailcone Battery Installation	96.30
96-33	Aft Battery Relay Installation	96.32
96-37	Aft Battery Relay Installation	96.36
96-41	Nose Battery Relay (14V)	96.40
96-43	Tailcone Battery Relay Installation	96.42
96-47	Circuit Breaker Panel	96.46
96-49	Test Switches and Gage Probes	96.48
96-53	Test Switches and Gage Probes	96.52
96-55	Belt Tension Actuator Time Delay and Test Plug	96.54
96-57	Collective-Activated Switch Installation	96.56
96-59	Carbon Monoxide Detector and Dimmer Installation	96.58
96-61	Electrical Components	96.60
96-63	Electrical Components	96.62
96-63B	Electrical Components	96.63A
96-65	Electrical Components	96.64
96-69	Power Booster Installation (14V to 28V)	96.68
96-71	Power Converter Installation (28V to 14V)	96.70
96-73	Power Converter Installation (28V to 14V)	96.72
96-75	Power Converter Installation (28V to 14V)	96.74
96-77	Battery Charging Post Installation	96.76
96-79	Engine Ground Straps Installation	96.78

Intentionally Blank

Intentionally Blank

FIGURE AND INDEX NUMBER	PART NUMBER	DESCRIPTION	PARTS AVAIL	QTY PER ASSY
		AFT BATTERY INSTALLATION (14V)*		
96-1-1	B415-1	Battery Relay (14-volt, Ref; see Figure 96-33 and 96-37 for complete installation)		
2	A780-22	Cable Assembly - Battery Negative	X	1
3	STD-1411**	Nut (Ref)		
4	STD-160**	Lockwasher (Ref)		
5	STD-8**	Washer (Ref)		
6	LW-25-1.13**	Bolt (Ref)		
7	95390A317	Circle Cotter	X	2
8	94924A009	Wingnut	X	2
9	A785-33	Hose	X	1
10	B277-12	Clamp	X	2
11	C449-3	Cover Assembly (Ref, see also Figure 71-31)		
12	MS21919WDG8	Clamp	X	1
13	AN3-4A	Bolt	X	1
14	MS21042L3	Nut	X	5
15	NAS1149F0332P	Washer	X	1
16	MS21919WDG18	Clamp	X	1
17	C654-44	Decal - "+ 12V"	X	1
18	C654-45	Decal - "- "	X	1
19	R5556	Seal (install using item 20)	X	A/R
20	B270-8qt	Adhesive (or B270-8qt)	X	A/R
21	C654-21	Decal - "Caution; Install Only Sealed Maintenance-Free Battery"	X	1
22	C955-9	Cover Assembly (14-volt ships; includes items 17 thru 21)	O	1
23	—	Bolt (M8)	O	2
24	—	Washer - Conical (M8)	O	2
25	MS35489-40	Grommet	X	2
26	A780-25	Cable Assembly - Battery Positive	X	1
27	B237-6	Battery (Sealed case, 12-volt; includes items 23 and 24. Concorde part no. RG25XC.)	X	1
28	NAS1149F0363P	Washer	X	8
29	A130-15	Spacer	X	4

NOTES * When C046-21 lower frame is installed.
 ** Lycoming part no.

Continues

FIGURE AND INDEX NUMBER	PART NUMBER	DESCRIPTION	PARTS AVAIL	QTY PER ASSY
AFT BATTERY INSTALLATION (14V)* (Cont'd)				
96-1-30	A954-1	Shield	X	1
31	A923-8	Rod (inboard)	X	1
32	C955-8	Battery Box Assembly (14-volt ships; includes items 14, 20, 22, 28 thru 30, and 33 thru 35)	X	1
33	C955-12	Pad (install using item 20)	X	1
34	MS27039C1-24	Screw	X	4
35	A955-4	Pad (install using item 20)	X	2
36	MS21042L08	Nut	X	4
37	NAS620-8L	Washer	X	4
38	A923-7	Rob (outboard)	X	1
39	C046-21	Lower Frame - (LH, Ref)		

NOTES * When C046-21 lower frame is installed.

Intentionally Blank

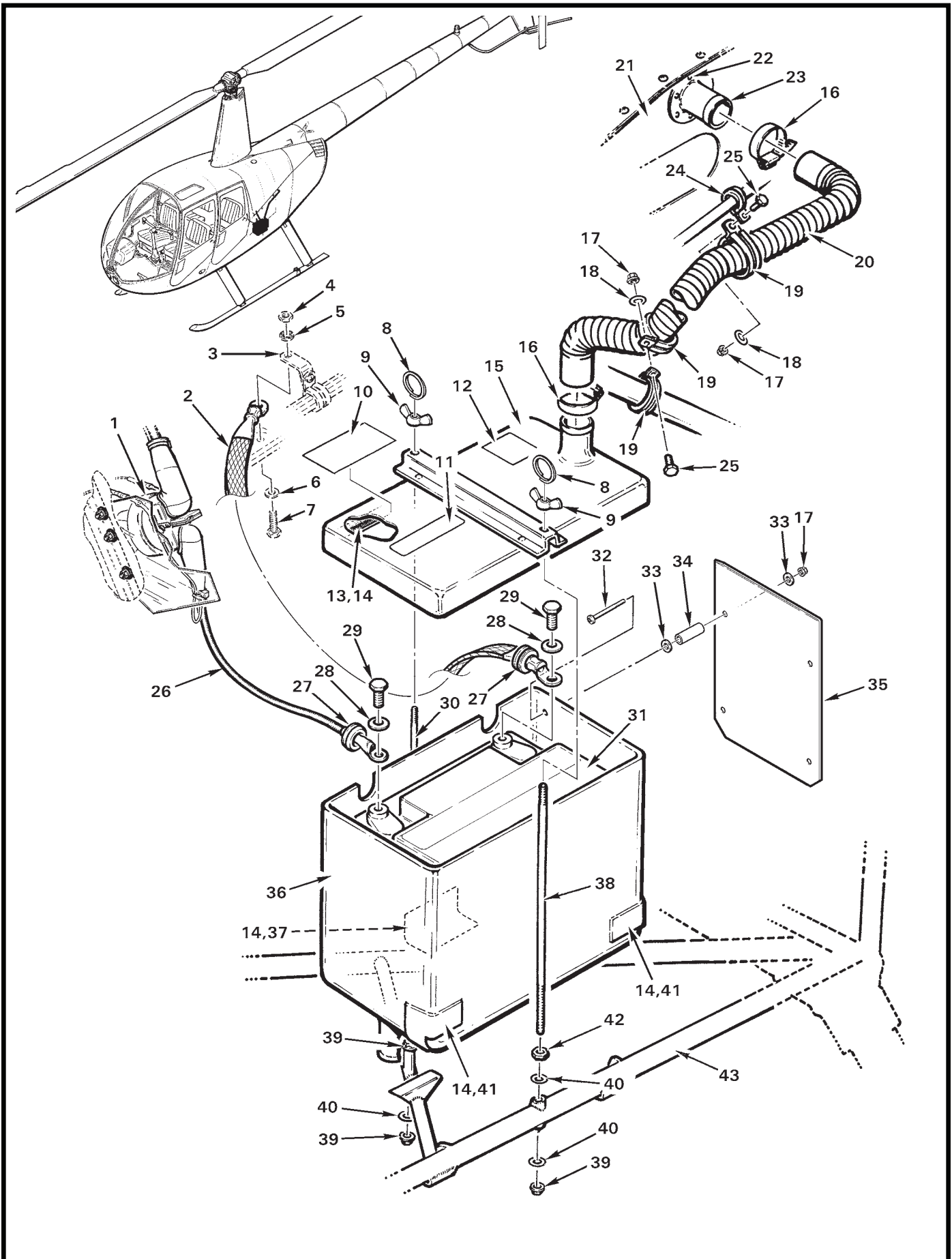

FIGURE AND INDEX NUMBER	PART NUMBER	DESCRIPTION	PARTS AVAIL	QTY PER ASSY
		AFT BATTERY INSTALLATION (14V)*		
96-5-1	B415-1**	Relay (Ref, 14-volt ships; see Figure 96-33 and Figure 96-37 for complete relay installation)		
2	A780-2	Cable Assembly - Battery Negative	X	1
3	C357-1	Clip (Ref)		
4	STD-1411***	Nut (Ref)		
5	STD-160***	Lockwasher (Ref)		
6	STD-8***	Washer (Ref)		
7	LW-25-1.13***	Bolt (Ref)		
8	95390A317	Circle Cotter	X	2
9	94924A009	Wingnut	X	2
10	C654-44	Decal "12V" (14-volt ships)	X	1
11	C654-21	Decal - "Caution; Install Only Sealed Maintenance-Free Battery"	X	1
12	C654-45	Decal - "—"	X	1
13	R5556	Seal (install using item 14)	X	A/R
14	B270-14	Adhesive (or B270-8qt)	X	A/R
15	C955-7	Cover Assembly (14-volt ships; includes items 10 thru 14)	O	1
16	B277-12	Clamp	X	2
17	MS21042L3	Nut	X	16
18	NAS1149F0332P	Washer	X	4
19	MS21919WDG16	Clamp	X	A/R
20	A785-22	Hose	X	1
21	C305-7	Panel - LH (Ref, see also Figure 71-35)		
22	MS20470AD3-3	Rivet (Ref)		
23	A372-1	Tube (Ref)		
24	MS21919WDG8	Clamp	X	1
25	AN3-4A	Bolt	X	2
26	A780-25	Cable Assembly - Battery Positive	X	1
27	MS35489-40	Grommet	X	2
28	—	Washer - Conical (M8)	O	2
29	—	Bolt (M8)	O	2
30	A923-4	Rod (inboard; for C046-1 and -19 frames)	X	1

NOTES * When C046-1 or -19 lower frame is installed.
 ** Ship S/N 0945 and higher. For ship S/N 0001 thru 0944, see Figure 96-33.
 *** Lycoming part no.

Continues

FIGURE AND INDEX NUMBER	PART NUMBER	DESCRIPTION	PARTS AVAIL	QTY PER ASSY
AFT BATTERY INSTALLATION (14V)* (Cont'd)				
96-5-31	B237-6	Battery (Sealed case, 12-volt; includes items 28 and 29. Ship S/N 0247 and higher. Concorde part no. RG25XC. To replace non-sealed battery, contact RHC.)	X	1
32	MS27039C1-24	Screw	X	4
33	NAS1149F0363P	Washer	X	8
34	A130-15	Spacer	X	4
35	A954-1	Shield	X	1
36	C955-3	Battery Box Assembly (14-volt ships; includes items 14, 15, 17 [4], 32 thru 35, 37, and 41)	X	1
37	A955-3	Pad (install using item 14)	X	1
38	A923-3	Rod (outboard; for C046-1 and -19 frames)	X	1
39	MS21042L08	Nut	X	3
40	NAS1149FN816P	Washer	X	3
41	A955-4	Pad (install using item 14)	X	2
42	AN340-8	Nut	X	1
43	C046-1 or -19	Frame (Ref)		

NOTES * When C046-1 or -19 lower frame is installed.

Intentionally Blank

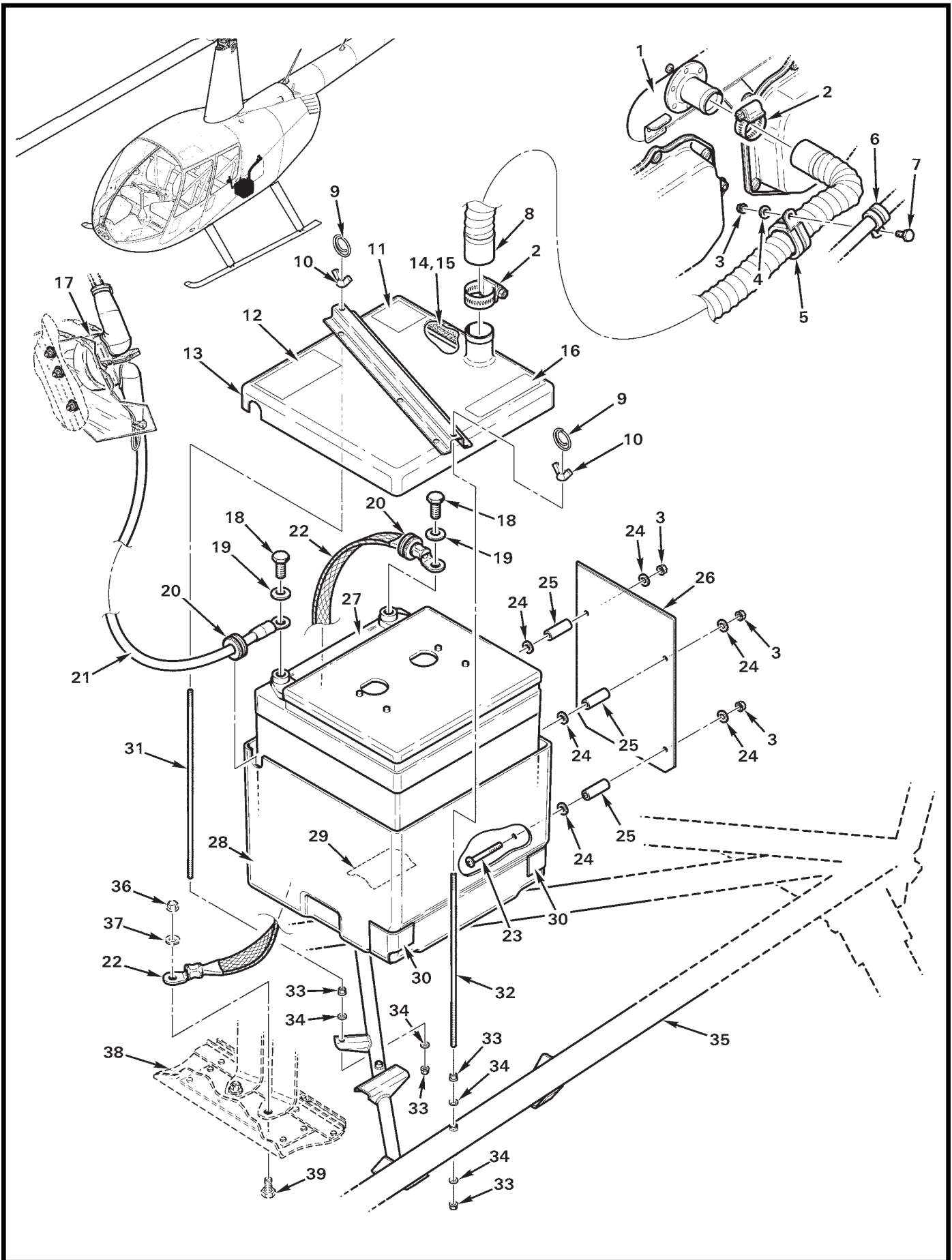

FIGURE AND INDEX NUMBER	PART NUMBER	DESCRIPTION	PARTS AVAIL	QTY PER ASSY
		AFT BATTERY INSTALLATION (28V)*		
96-9-1	C449-3	Cover Assembly (Ref, see also Figure 71-31)		
2	B277-12	Clamp	X	2
3	MS21042L3	Nut	X	5
4	NAS1149F0332P	Washer	X	1
5	MS21919WDG18	Clamp	X	1
6	MS21919WDG8	Clamp	X	1
7	AN3-4A	Bolt	X	1
8	A785-33	Hose	X	1
9	95390A317	Circle Cotter	X	2
10	94924A009	Wingnut	X	2
11	C654-45	Decal - "—"	X	1
12	C654-43	Decal - "+ 24V"	X	1
13	C955-11	Cover Assembly (28-volt ships; includes items 11, 12, and 14 thru 16)	O	1
14	A540-4	Seal (install using item 15)	X	A/R
15	B270-14	Adhesive (or B270-8qt)	X	A/R
16	C654-21	Decal - "Caution; Install Only Sealed Maintenance-Free Battery"	X	1
17	B415-2	Relay (28-volt, Ref; see Figure 96-33 and Figure 96-37)		
18	—	Bolt (M8)	O	2
19	—	Washer - Conical (M8)	O	2
20	MS35489-40	Grommet	X	2
21	A780-25	Cable Assembly - Battery Positive	X	1
22	A780-22	Cable Assembly - Battery Negative	X	1
23	MS27039C1-24	Screw	X	4
24	NAS1149F0363P	Washer	X	8
25	A130-15	Spacer	X	4
26	A954-1	Shield	X	1
27	B237-4	Battery (Sealed case, 24-volt; includes items 18 and 19. Concorde part no. RG24-15.)	X	1
28	C955-10	Battery Box Assembly (28-volt ships; includes items 3, 13, 15, 23 thru 26, 29, and 30)	X	1
29	C955-12	Pad (install using item 15)	X	1

NOTES * When C046-21 lower frame is installed.

Continues

FIGURE AND INDEX NUMBER	PART NUMBER	DESCRIPTION	PARTS AVAIL	QTY PER ASSY
AFT BATTERY INSTALLATION (28V)* (Cont'd)				
96-9-30	A955-4	Pad (install using item 15)	X	2
31	A923-10	Rod (inboard)	X	1
32	A923-9	Rod (outboard)	X	1
33	MS21042L08	Nut	X	4
34	NAS620-8L	Washer	X	4
35	C046-21	Lower Frame - (LH, Ref)		
36	MS21042L4	Nut (Ref)		
37	NAS1149F0432P	Washer (Ref)		
38	C015-3	Skin (LH cabin belly; Ref)		
39	AN4-4A	Bolt (Ref)		

NOTES * When C046-21 lower frame is installed.

Intentionally Blank

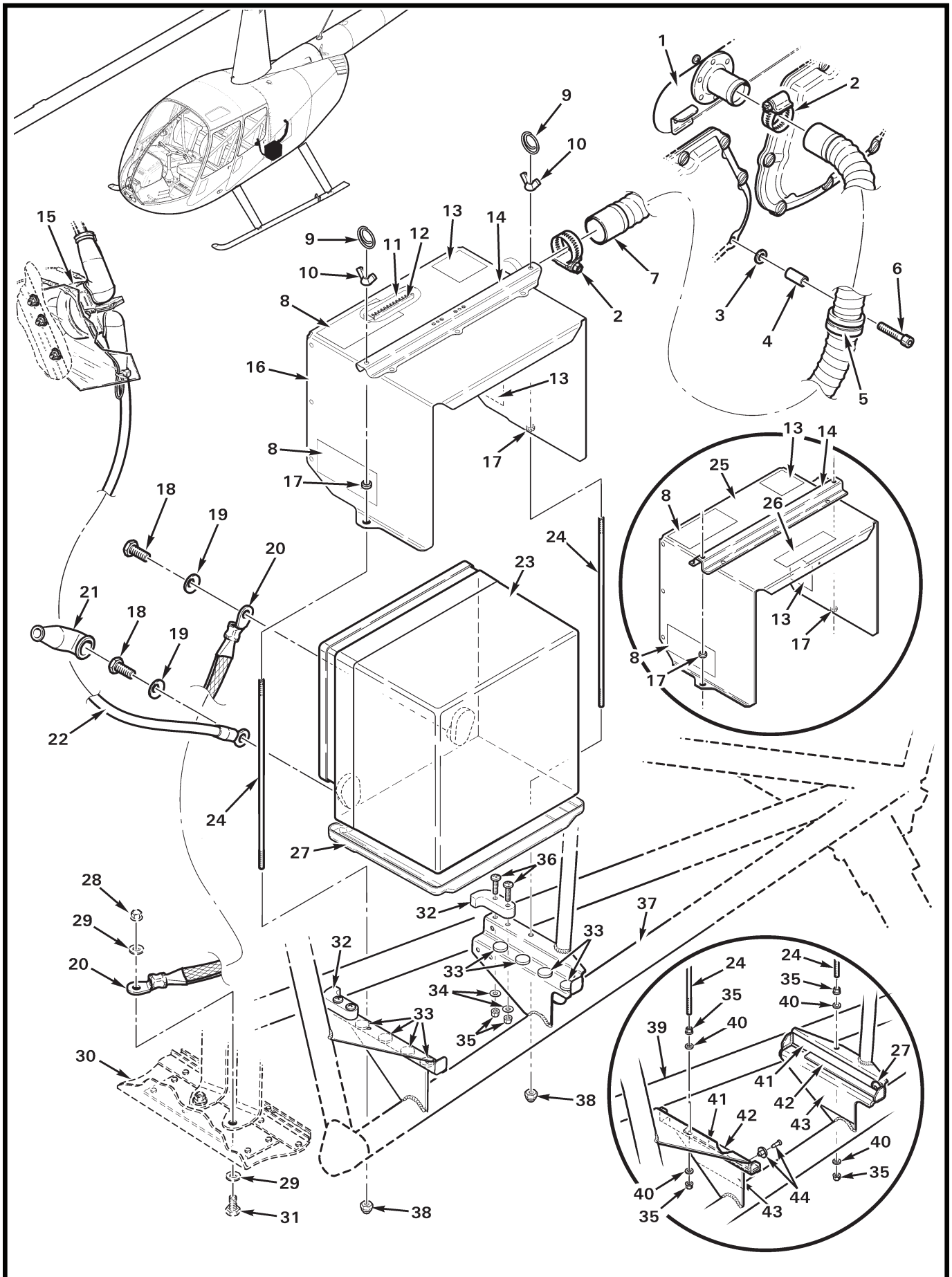

FIGURE AND INDEX NUMBER	PART NUMBER	DESCRIPTION	PARTS AVAIL	QTY PER ASSY
		AFT BATTERY INSTALLATION (28V)		
96-12A-1	C449-3	Cover Assembly (Ref, see also Figure 71-31)		
2	B277-12	Clamp	X	2
3	NAS1149F0432P	Washer	X	1
4	C130-34	Spacer	X	1
5	MS21333-107	Clamp	X	1
6	NAS1352-4H20P	Screw	X	1
7	A785-35	Hose	X	1
8	C654-43	Decal - "+ 24V"	X	2
9	95390A317	Circle Cotter	X	2
10	94924A009	Wing Nut	X	2
11	A409-1	Angle	X	1
12	A225-1	Grommet	X	A/R
13	C654-45	Decal - "-"	X	2
14	A922-6	Channel (Ref)	X	1
15	B415-2	Relay (Ref, see Figures 96-33 and 96-37)		
16	D809-3	Cover Assembly (Incl items 8, 11 thru 14, and 17)	X	1
17	NAS557-3A	Grommet	X	2
18	—	Bolt (M8)	O	2
19	—	Washer - Conical (M8)	O	2
20	A780-22	Cable Assembly - Battery Negative	X	1
21	MS25171-2S	Nipple	X	1
	MS25171-4S	Nipple (superseded by MS25171-2S, this location)	X	1
22	A780-46	Cable Assembly - Battery Positive	X	1
23	B237-4	Battery (Sealed case, 24-volt; includes items 18 and 19. Concorde part no. RG24-15.)	X	1
24	A923-10	Rod	X	2
25	D809-1	Cover Assembly (Incl items 8, 13, 14, 17, and 26)	X	1
26	C654-21	Decal - "Caution; Install Only Sealed Maintenance-Free Battery"	X	1
27	G123-3	Tray (for B237-4 Battery)	X	1
28	D210-4	Nut (Ref)		
29	NAS1149F0432P	Washer (Ref)		
30	C015-3	Skin (LH cabin belly; Ref)		
31	AN4-4A	Bolt (Ref)		
32	D131-2	Retainer	X	2

NOTES

Continues

FIGURE AND INDEX NUMBER	PART NUMBER	DESCRIPTION	PARTS AVAIL	QTY PER ASSY
AFT BATTERY INSTALLATION (28V) (Cont'd)				
96-12A-33	G405-2	Bumper	X	8
34	NAS1149FN816P	Washer	X	4
35	MS21042L08	Nut	X	6
36	MS27039C0810	Screw	X	2
37	C046-26	Frame (Ref)		
38	B340-4	Nut	X	2
39	C046-23	Frame (Ref; see Figure 53-19)		
40	NAS620-8L	Washer	X	4
41	A701-3	Tape (0.5 in. wide polyethylene)	X	A/R
42	D832-1	Strip	X	2
43	PPR-4850B	Push Rivet	X	1

NOTES

Intentionally Blank

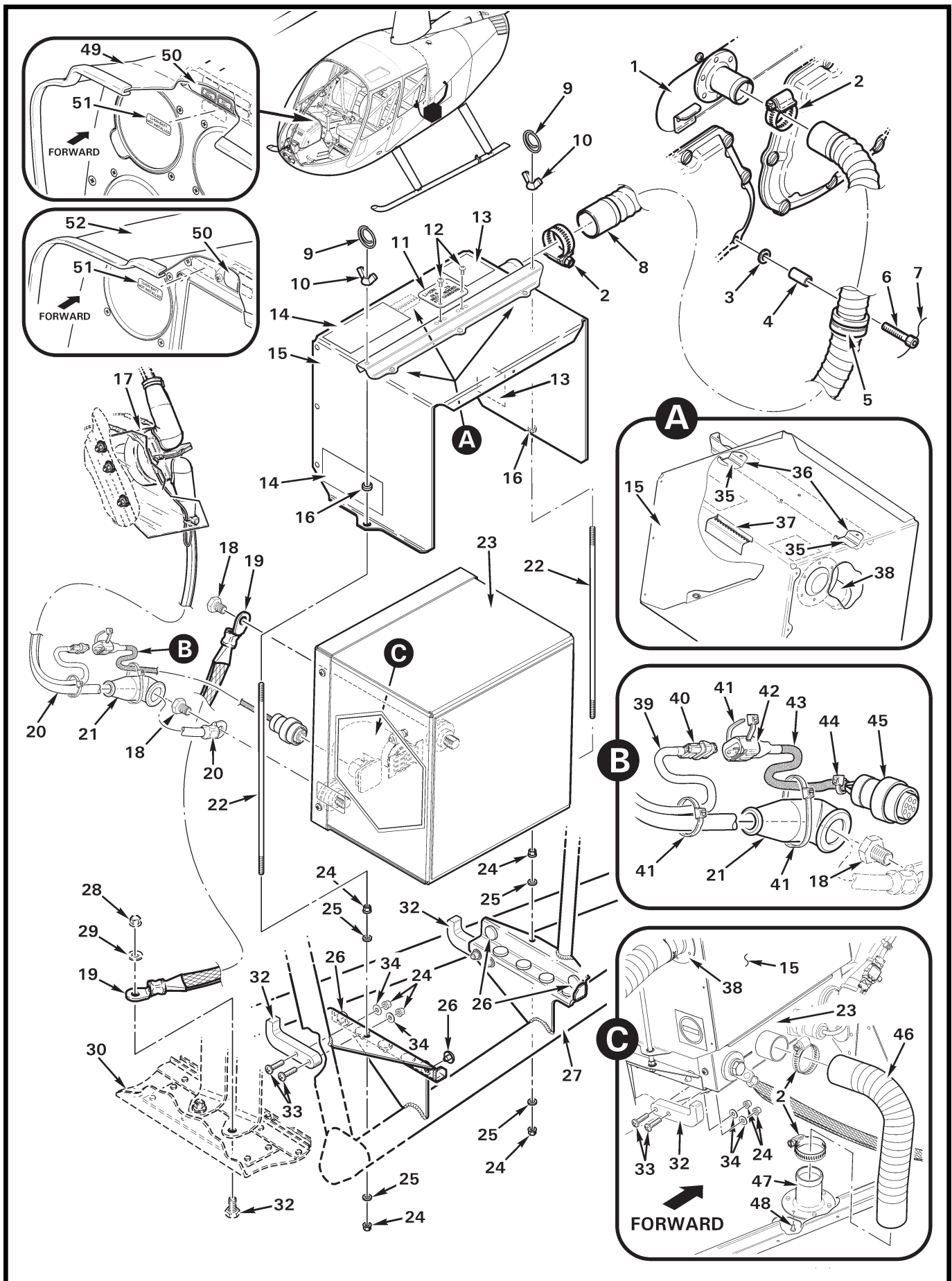

FIGURE AND INDEX NUMBER	PART NUMBER	DESCRIPTION	PARTS AVAIL	QTY PER ASSY
		AFT BATTERY INSTALLATION (28V LITHIUM-ION)		
96-13A-1	C449-3	Cover Assembly (Ref, see also Figure 71-31)		
2	B277-12	Clamp	X	2
3	NAS1149F0432P	Washer	X	1
4	C130-34	Spacer	X	1
5	MS21333-107	Clamp	X	1
6	NAS1352-4H20P	Screw	X	1
7	MS20995C32	0.032-in. dia. Safety Wire	X	A/R
8	A785-35	Hose	X	1
9	95390A317	Circle Cotter	X	2
10	94924A009	Wingnut	X	2
11	G598-4	Cover	X	1
12	MS35206-213	Screw	X	2
13	C654-45	Decal – “ – ”	X	2
14	C654-43	Decal – “ + 24V ”	X	2
15	D809-3	Cover Assembly (Incl items 13, 14, 16, and 35 thru 38)	X	1
16	NAS557-3A	Grommet	X	2
17	B415-2	Relay (Ref, see Figure 96-33 and Figure 96-37)		
18	—	Bolt (M8)	O	2
19	A780-22	Cable Assembly – Battery Negative	X	1
20	A780-46	Cable Assembly – Battery Positive	X	1
21	MS25171-2S	Nipple	X	1
22	A923-10	Rod	X	2
23	D237-2	Battery (Sealed case, Lithium-Ion, 24-volt; includes item 18. Mid-Continent part no. 6430017-2 (TB17).)	X	1
24	MS21042L08	Nut	X	4
25	NAS620-8L	Washer	X	4
26	G405-2	Bumper	X	4
27	C046-26	Frame (Ref)		
28	D210-4	Nut (Ref)		
29	NAS1149F0432P	Washer (Ref)		
30	C015-3	Skin (LH cabin belly; Ref)		
31	AN4-4A	Bolt (Ref)		
32	D131-3	Retainer	X	2

NOTES

Continues

FIGURE AND INDEX NUMBER	PART NUMBER	DESCRIPTION	PARTS AVAIL	QTY PER ASSY
AFT BATTERY INSTALLATION (28V LITHIUM-ION) (Cont'd)				
96-13A-33	MS27039C0810	Screw	X	4
34	NAS1149FN816P	Washer	X	4
35	A701-3	Tape	X	A/R
36	A922-7	Bumper (Ref)		
37	A225-1	Grommet (1.95-inch length)	X	1
38	A372-1	Tube (Ref)		
39	C859	Harness Assembly – Electrical (Ref, cabin; includes item 40)		
40	D269-2	Receptacle (Ref)		
	C859-2819	Wire (Ref)		
	C859-2882	Wire (Ref)		
41	MS3367-5-9	Ty-Rap	X	A/R
42	D269-1	Plug	X	1
43	F693-6	Harness Assembly (Incl items 42, 44, and 45)	X	1
44	MS3367-4-0	Ty-rap	X	1
45	9018048	Plug	X	1
46	A785-42	Hose	X	1
47	A372-1	Tube	X	1
48	MS20470AD3	Rivet	X	6
49	G050	Console Assembly (Ref)		
50	G198	Panel (Ref)		
51	D819-9*	Decal	X	1
52	G060	Console Assembly (Ref)		

NOTES * When D237-2 is not installed.

Intentionally Blank

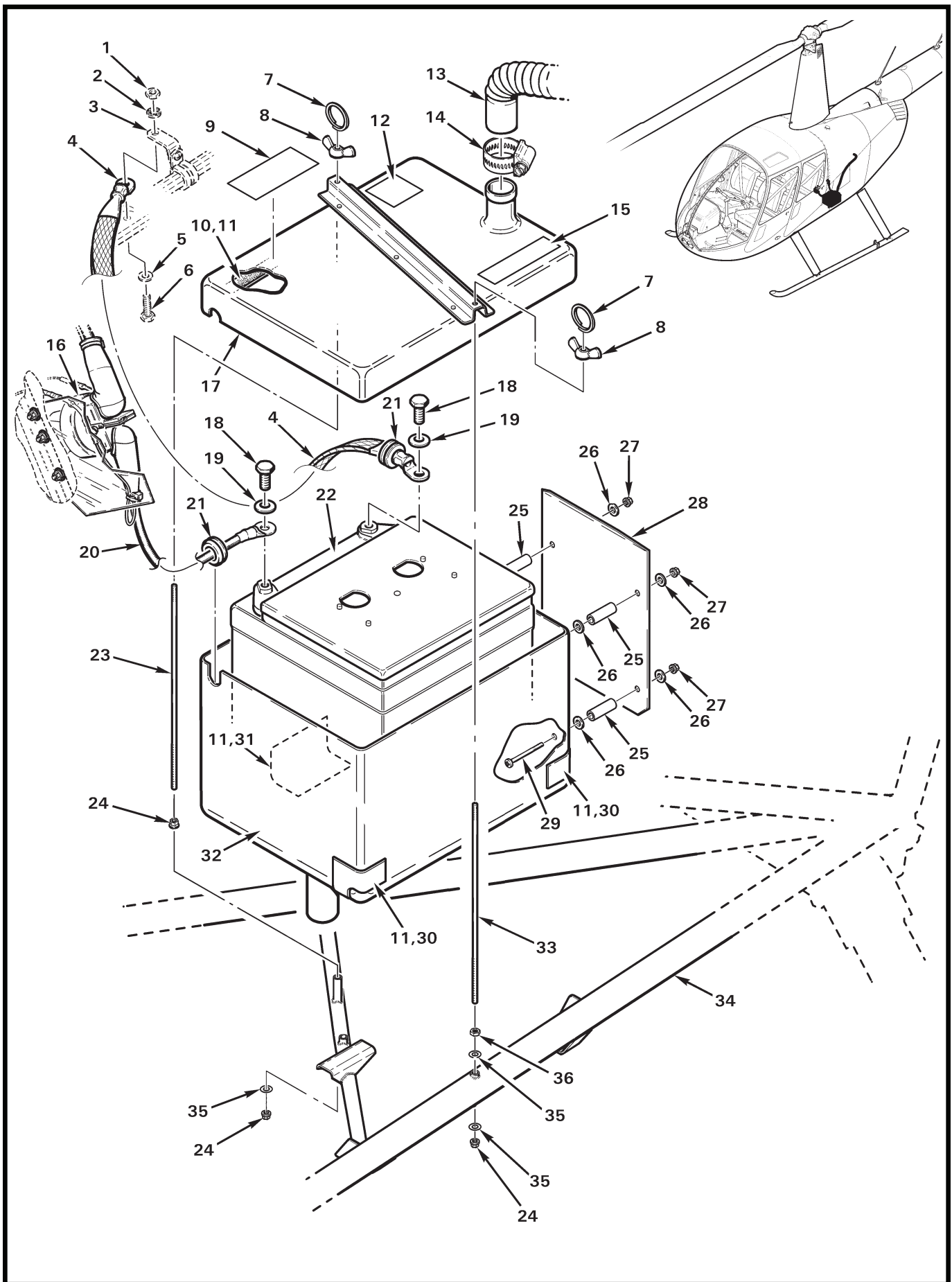

FIGURE AND INDEX NUMBER	PART NUMBER	DESCRIPTION	PARTS AVAIL	QTY PER ASSY
AFT BATTERY INSTALLATION (28V)*				
96-15-1	STD-1411**	Nut (Ref)		
2	STD-160**	Lockwasher (Ref)		
3	C357-1	Clip (Ref)		
4	A780-2	Cable Assembly - Battery Negative	X	1
5	STD-8**	Washer (Ref)		
6	LW-25-1.13**	Bolt (Ref)		
7	95390A317	Circle Cotter	X	2
8	94924A009	Wingnut	X	2
9	C654-43	Decal - "24V" (28-volt ships)	X	1
10	R5556	Seal (install using item 11)	X	A/R
11	B270-8QT	Adhesive	X	A/R
12	C654-45	Decal - "—"	X	1
13	A785-22	Hose	X	1
14	B277-12	Clamp	X	2
15	C654-21	Decal - "Caution; Install Only Sealed Maintenance Free Battery"	X	1
16	B415-2	Relay (Ref, 28-volt ships; see Figure 96-33 and Figure 96-37 for complete installation.)		
17	C955-6	Cover Assembly (28-volt ships; includes items 9, 10, 12 and 15)	O	1
18	—	Bolt (M8)	O	2
19	—	Washer - Conical (M8)	O	2
20	A780-25	Cable Assembly - Battery Positive	X	1
21	MS35489-40	Grommet	X	2
22	B237-4	Battery (Sealed case, 24-volt; includes items 18 and 19. Concorde part no. RG24-15.)	X	1
23	A923-6	Rod (inboard)	X	1
24	MS21042L08	Nut	X	3
25	A130-15	Spacer	X	4
26	NAS1149F0363P	Washer	X	8
27	D210-3	Nut	X	16
28	A954-1	Shield	X	1
29	MS27039C1-24	Screw	X	4

NOTES * When C046-1 or -19 lower frame is installed.
 ** Lycoming part no.

Continues

FIGURE AND INDEX NUMBER	PART NUMBER	DESCRIPTION	PARTS AVAIL	QTY PER ASSY
AFT BATTERY INSTALLATION (28V)* (Cont'd)				
96-15-30	A955-4	Pad (install using item 11)	X	2
31	A955-3	Pad (install using item 11)	X	1
32	C955-5	Battery Box Assembly (28-volt ships; includes items 11, 17, 25 thru 29, 30, and 31)	X	1
33	A923-5	Rod (outboard)	X	1
34	C046-1 or -19	Frame (Ref)		
35	NAS1149FN816P	Washer	X	3
36	AN340-8	Nut	X	1

NOTES * When C046-1 or -19 lower frame is installed.

Intentionally Blank

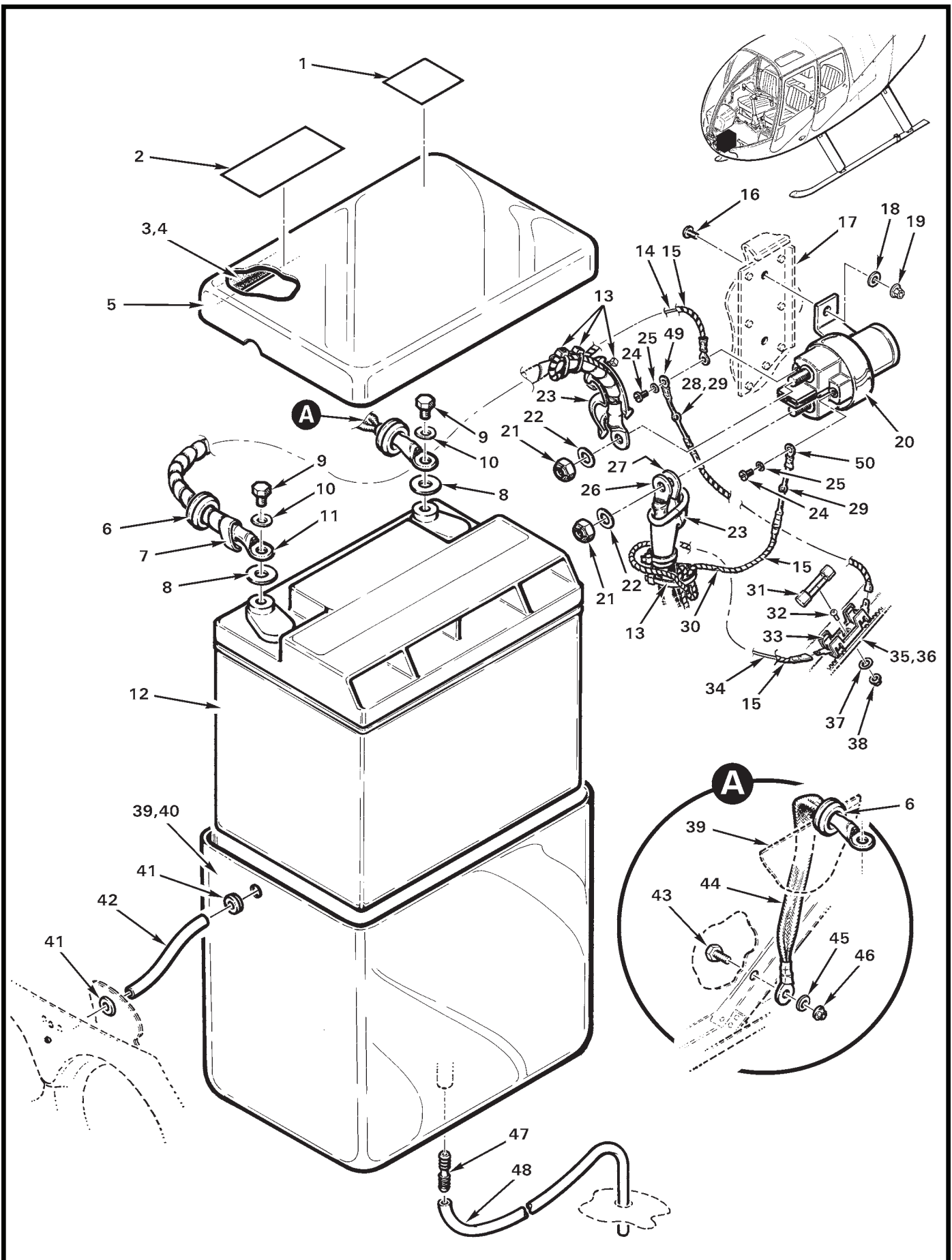

FIGURE AND INDEX NUMBER	PART NUMBER	DESCRIPTION	PARTS AVAIL	QTY PER ASSY
NOSE BATTERY INSTALLATION (14V)				
96-19-1	C654-45	Decal - "—"	X	1
2	C654-44	Decal - "12V +"	X	1
3	R5556	Seal (install using item 4)	X	A/R
4	B270-14	Adhesive (or B270-8qt)	X	A/R
5	A540-10	Cover Assembly (Incl items 1 thru 4)	O	1
6	MS35489-40	Grommet	X	2
7	B161-8	Spirap	X	A/R
8	A141-31	Washer (Ref; no longer available, no longer required.)		
9	—	Bolt (M8)	O	2
10	—	Washer - Conical (M8)	O	2
11	A780-35	Cable Assembly - Battery Positive (Incl item 14)	X	1
12	B237-6	Battery (Sealed case, 12-volt; includes items 9 and 10. Concorde part no. RG25XC.)	X	1
13	MS3367-4-9	Ty-Rap	X	A/R
14	A780-64	Wire (Ref)		
15	B161-2	Spirap	X	A/R
16	MS27039C1-06	Screw	X	2
17	A547-1	Channel Mount (Ref)		
18	NAS1149F0332P	Washer	X	2
19	MS21042L3	Nut	X	2
20	B415-1*	Relay (Incl items 21, 22, 24, and 25)	X	1
21	MS21044B5	Nut	O	2
22	O1000424	Washer (conical)	O	2
23	MS25171-4S	Nipple	X	2
24	O1003621	Screw	O	2
25	O1004635	Washer	O	2
26	A780-20	Cable (to alternator shunt; C067-580 wire)	X	1
27	C067-587	Cable (to starter)	X	1
28	B304-8	Diode Assembly (Includes items 31 thru 33, 37, 38, and 49 as an assembled unit.)	X	1
29	A15A	Diode (cover with B158-103 heat shrink)	X	1
	B158-103	Heat Shrink (clear)	X	A/R

NOTES * Ship S/N 0945 and higher. For ship S/N 0001 thru 0944, see Figure 96-41.

Continues

FIGURE AND INDEX NUMBER	PART NUMBER	DESCRIPTION	PARTS AVAIL	QTY PER ASSY
NOSE BATTERY INSTALLATION (14V) (Cont'd)				
96-19-30	C059-141	Wire (Ref)		
31	AGC-3	Fuse (3-amp)	X	1
32	MS35206-228	Screw	X	1
33	D262-1	Fuse Block (alternate part no. 354601)	X	1
34	C059-142	Wire (Ref)		
35	MS21266-1N	Grommet (Ref; install using item 36)	X	A/R
36	B270-8qt	Adhesive	X	A/R
37	NAS1149FN616P	Washer	X	1
38	MS21042L06	Nut	X	1
39	A540-2	Box Bottom	O	1
40	A540-12	Battery Box Assembly (Incl items 5 and 39)	X	1
41	MS35489-6	Grommet	X	2
42	A691-3	Tube (install using item 36)	X	1
43	AN4-3A	Bolt	X	1
44	A780-2	Cable - Battery Negative	X	1
45	NAS1149F0432P	Washer	X	1
46	MS21042L4	Nut	X	1
47	O705T-015	Connector - Tube	X	1
48	D233-1	Drain Tube Assembly (Incl items 47 and R5022 tube)	X	1
49	B260-3	Terminal	X	1
50	B260-2	Terminal	X	1
* * *				
51	KI-153	Forward Battery Relay Upgrade Kit (For 14-volt ship S/Ns 0001 thru 0944. Includes items 6, 7, 11, 13, 15, 16, 18 thru 20, 23, and 52 thru 56.)	X	1
52	B158-103	Heat Shrink (1 in. length)	X	1
53	B161-4	Spirap	X	1
54	MS3367-5-9	Ty-Rap	X	5
55	MS3367-7-9	Ty-Rap	X	5
56	B260-2	Terminal	X	2

NOTES

Intentionally Blank

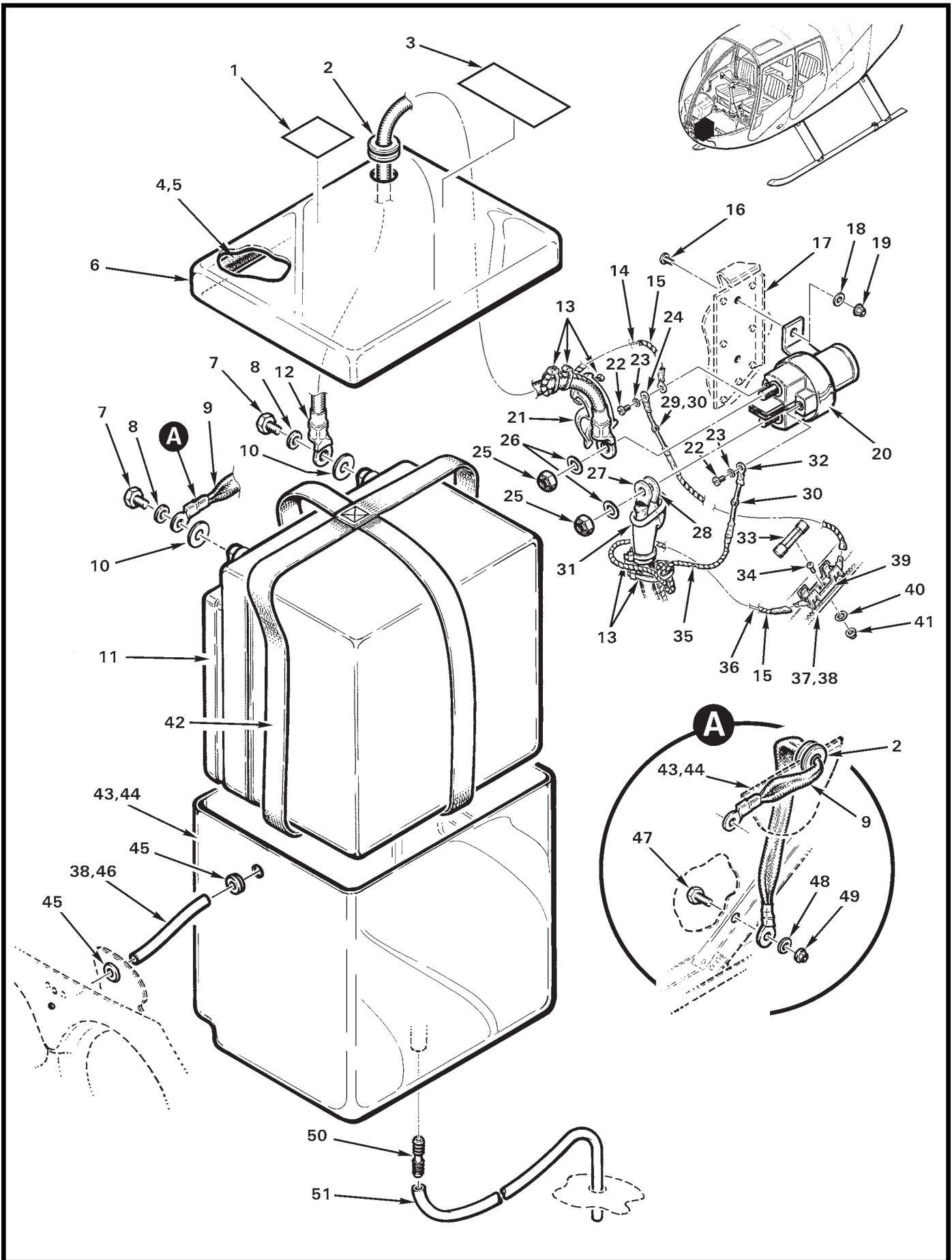

FIGURE AND INDEX NUMBER	PART NUMBER	DESCRIPTION	PARTS AVAIL	QTY PER ASSY
NOSE BATTERY INSTALLATION (28V)				
96-23-1	C654-45	Decal - “-”	X	1
2	MS35489-40	Grommet	X	2
3	C654-43	Decal - “+ 24V”	X	1
4	R5556	Seal (install using item 5)	X	A/R
5	B270-14	Adhesive (or B270-8qt)	X	A/R
6	D689-3	Cover Assembly (Revision “D” and higher)	O	1
7	—	Bolt (M8)	O	2
8	—	Washer - Conical (M8)	O	2
9	A780-22	Cable - Battery Negative	X	1
10	A141-31	Washer (Ref; no longer available, no longer required)		
11	B237-4	Battery (Sealed case; 24-volt, includes items 7 and 8. Concord par no. RG24-15.)	X	1
12	A780-40	Cable - Battery Positive (Includes item 14; use only with item 44.)	X	1
13	MS3367-4-9	Ty-Rap	X	A/R
14	A780-64	Wire (Ref)		
15	B161-2	Spirap (0.125 in. dia.)	X	A/R
16	MS27039C1-06	Screw	X	2
17	A547-1	Channel Mount (Ref)		
18	NAS1149F0332P	Washer	X	2
19	MS21042L3	Nut	X	2
20	B415-2	Relay (Incl items 22, 23, 25, and 26)	X	1
21	MS25171-2S	Nipple	X	1
22	01003621	Screw (M4 x 6)	O	2
23	01004635	Washer (M4)	O	2
24	B260-3	Terminal	X	1
25	MS21044B5	Nut	O	2
26	01000424	Washer (conical)	O	2
27	A780-23	Cable (to shunt)	X	1
28	C067-1386	Cable (to starter)	X	1
29	B304-8	Diode Assembly (Includes items 24, 30, 33, 34, and 39 thru 41 as an assembled unit.)	X	1
30	A15A	Diode (cover with B158-103 heat shrink)	X	1
	B158-103	Heat Shrink	X	A/R

NOTES

Continues

FIGURE AND INDEX NUMBER	PART NUMBER	DESCRIPTION	PARTS AVAIL	QTY PER ASSY
NOSE BATTERY INSTALLATION (28V) (Cont'd)				
96-23-31	MS25171-4S	Nipple	X	1
32	B260-2	Terminal	X	1
33	AGC-3	Fuse (3-amp)	X	1
34	MS35206-228	Screw	X	1
35	C059-141	Wire (Ref)		
36	C059-142	Wire (Ref)		
37	MS21266-1N	Grommet (Ref; install using item 38)	X	1
38	B270-8qt	Adhesive	X	1
39	D262-1	Fuse Block (alternate part no. 354601)	X	1
40	NAS1149FN616P	Washer	X	1
41	MS21042L06	Nut	X	1
42	D693-1	Strap Assembly	X	1
43	D689-2	Box Bottom	O	1
44	D689-5	Battery Box Assembly (Incl items 1, 3 thru 6, and 43)	X	1
45	MS35489-6	Grommet	X	2
46	A691-3	Tube - Vent (install using item 38)	X	1
47	AN4-3A	Bolt	X	1
48	NAS1149F0432P	Washer	X	1
49	MS21042L4	Nut	X	1
50	0705T-015	Connector - Tube	X	1
51	D233-1	Drain Tube Assembly (Incl items 50 and R5022 tube)	X	1

NOTES

Intentionally Blank

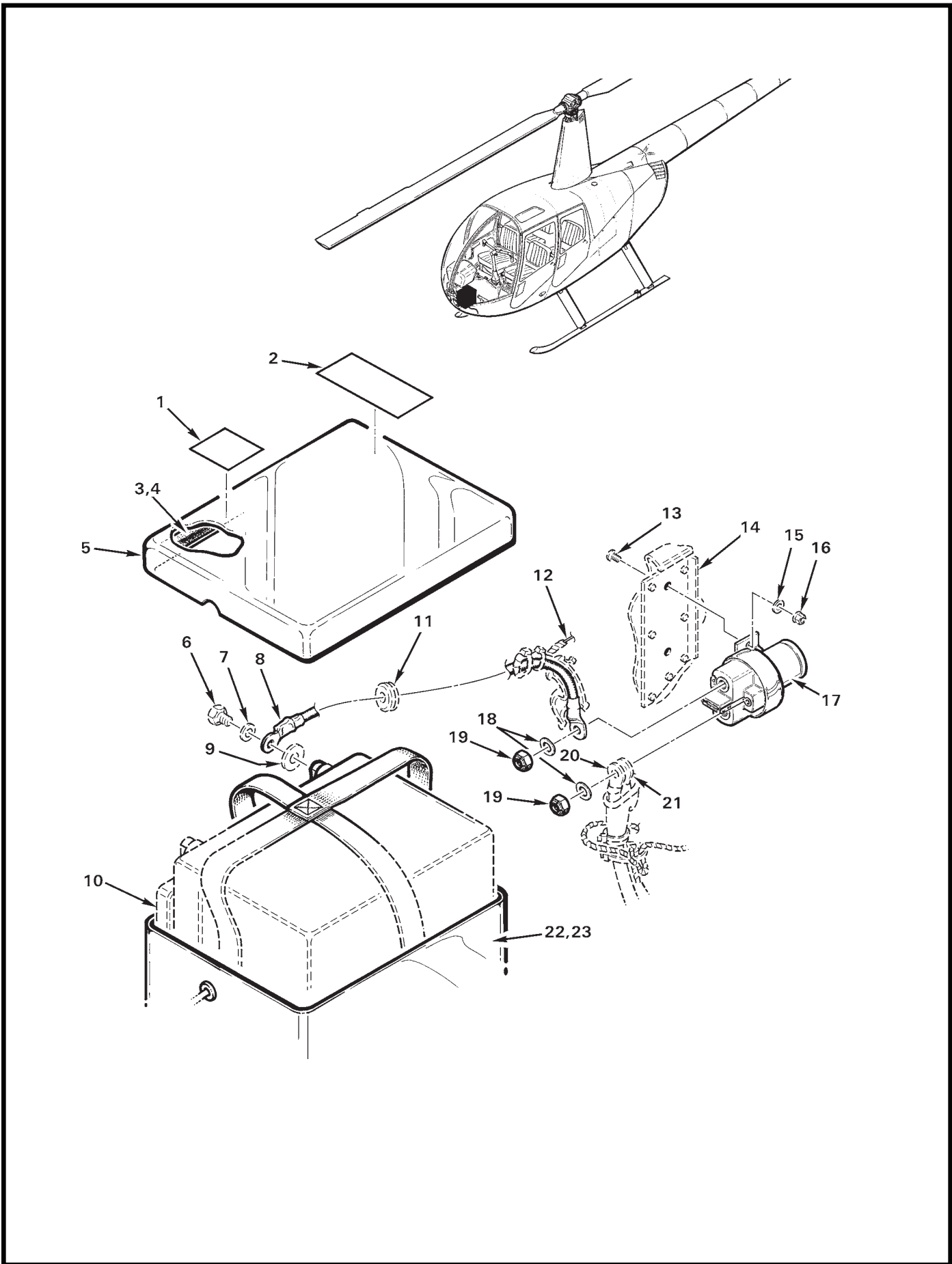

FIGURE AND INDEX NUMBER	PART NUMBER	DESCRIPTION	PARTS AVAIL	QTY PER ASSY
NOSE BATTERY INSTALLATION (28V)				
96-27-1	C654-45	Decal - “-”	X	1
2	C654-43	Decal - “ + 24V”	X	1
3	R5556	Seal (install using item 4)	X	A/R
4	B270-8	Adhesive	X	A/R
5	D689-3	Cover Assembly (Rev “C” and prior, Ref; no longer available. Order items 12 and 44 from Figure 96-23 when replacing.)		
6	—	Bolt (M8)	O	2
7	—	Washer - Conical (M8)	O	2
8	A780-21	Cable - Battery Positive (Incl item 12)	X	1
9	A141-31	Washer (Ref; no longer available, no longer required.)		
10	B237-4	Battery (Sealed case; 24-volt, includes items 6 and 7. Concord part no. RG24-15.)	X	1
11	MS35489-40	Grommet (Ref)		
12	A780-64	Wire (Ref)		
13	MS27039C1-06	Screw	X	2
14	A547-1	Channel Mount (Ref)		
15	NAS1149F0332P	Washer	X	2
16	MS21042L3	Nut	X	2
17	B415-2	Relay (Ref, see Figure 96-33 and Figure 96-37.)		
18	O1000424	Washer (conical)	O	2
19	MS21044B5	Nut	O	2
20	A780-23	Cable (to shunt)	X	1
21	C067-1386	Cable (to starter)	X	1
22	D689-2	Box Bottom (Ref)	O	1
23	D689-5	Battery Box Assembly (Ref, Revision “C” and prior, no longer available. Used with items 5 and 22. Order items 5 and 22. Order items 12 and 44 from Figure 96-19 when replacing.)		

NOTES

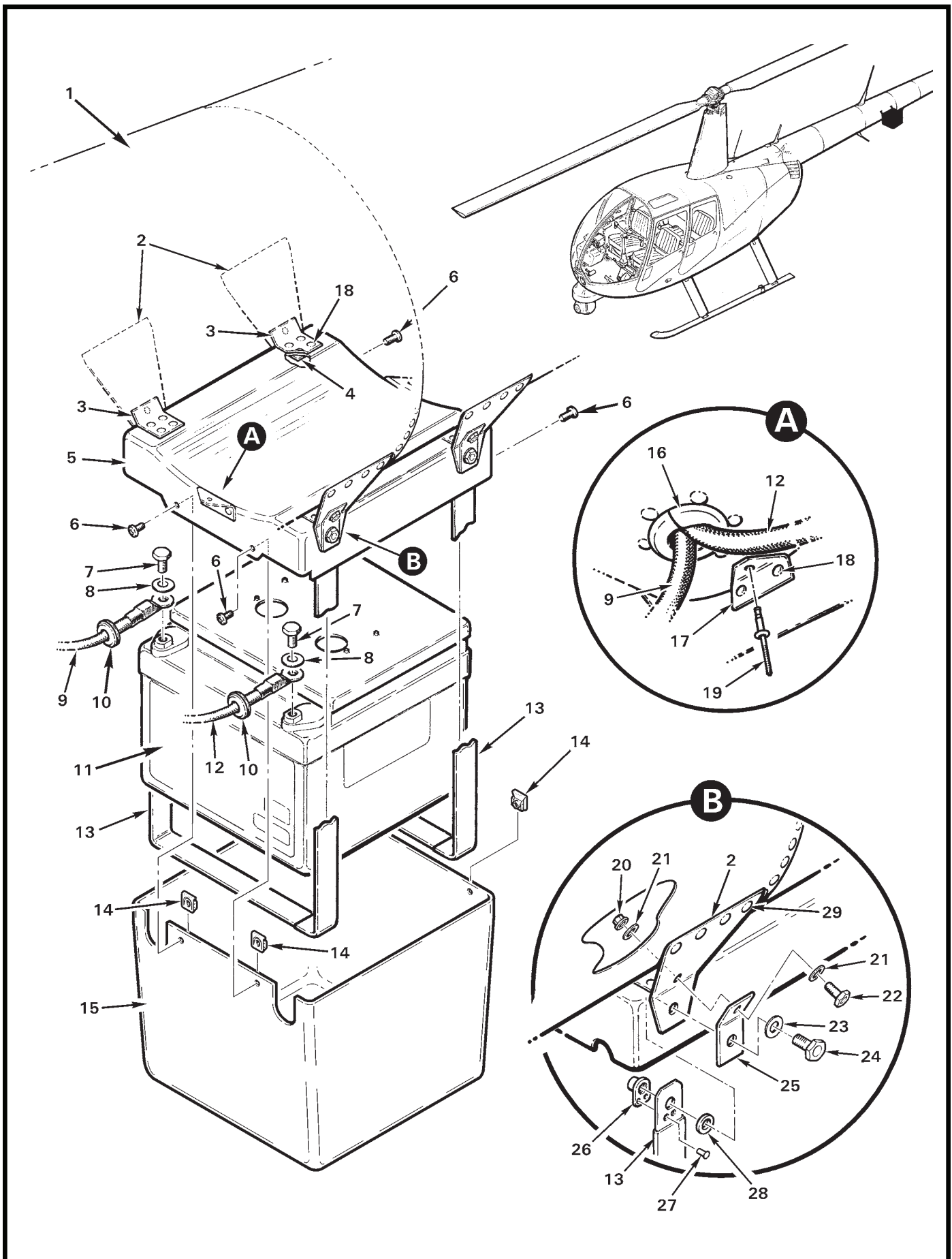

FIGURE AND INDEX NUMBER	PART NUMBER	DESCRIPTION	PARTS AVAIL	QTY PER ASSY
TAILCONE BATTERY INSTALLATION				
96-29-1	C023	Tailcone Assembly (Ref, see Figure 53-25)		
2	D362-7	Strap	X	4
3	D362-9	Angle	X	4
4	D362-5	Doubler	X	4
5	D361-6*	Cover Assembly (Incl items 3, 4, 17, and 18)	X	1
6	MS27039C0806	Screw	X	4
7	—	Bolt (M8)	O	2
8	—	Washer (conical, M8)	O	2
9	A780-12	Cable Assembly - Battery Negative	X	1
10	MS35489-41X	Grommet	X	2
11	B237-4	Battery (Sealed case; 24-volt, includes items 7 and 8. Concord part RG24-15.)	X	1
12	A780-29	Cable Assembly - Battery Positive	X	1
13	D362-10	Strap Assembly (Incl items 26 and 27)	X	2
14	B162-2	Clipnut	X	4
15	D540-5	Box	X	1
16	MS35489-19	Grommet	X	1
17	D362-6	Angle	X	2
18	MS20470AD4	Rivet	X	20
19	NAS9301B-4-02	Rivet	X	2
20	MS21042L3	Nut	X	4
21	NAS1149F0332P	Washer	X	8
22	NAS6603-3	Bolt	X	4
23	NAS1149F0432P	Washer	X	4
24	NAS6604-3	Bolt	X	4
25	D362-8	Angle	X	4
26	MS21086L4	Nutplate	X	4
27	NAS1097AD3	Rivet	X	8
28	A130-47	Spacer	X	4
29	NAS9301B-5-02	Rivet	X	16

NOTES * D361 Revision "G" and higher.

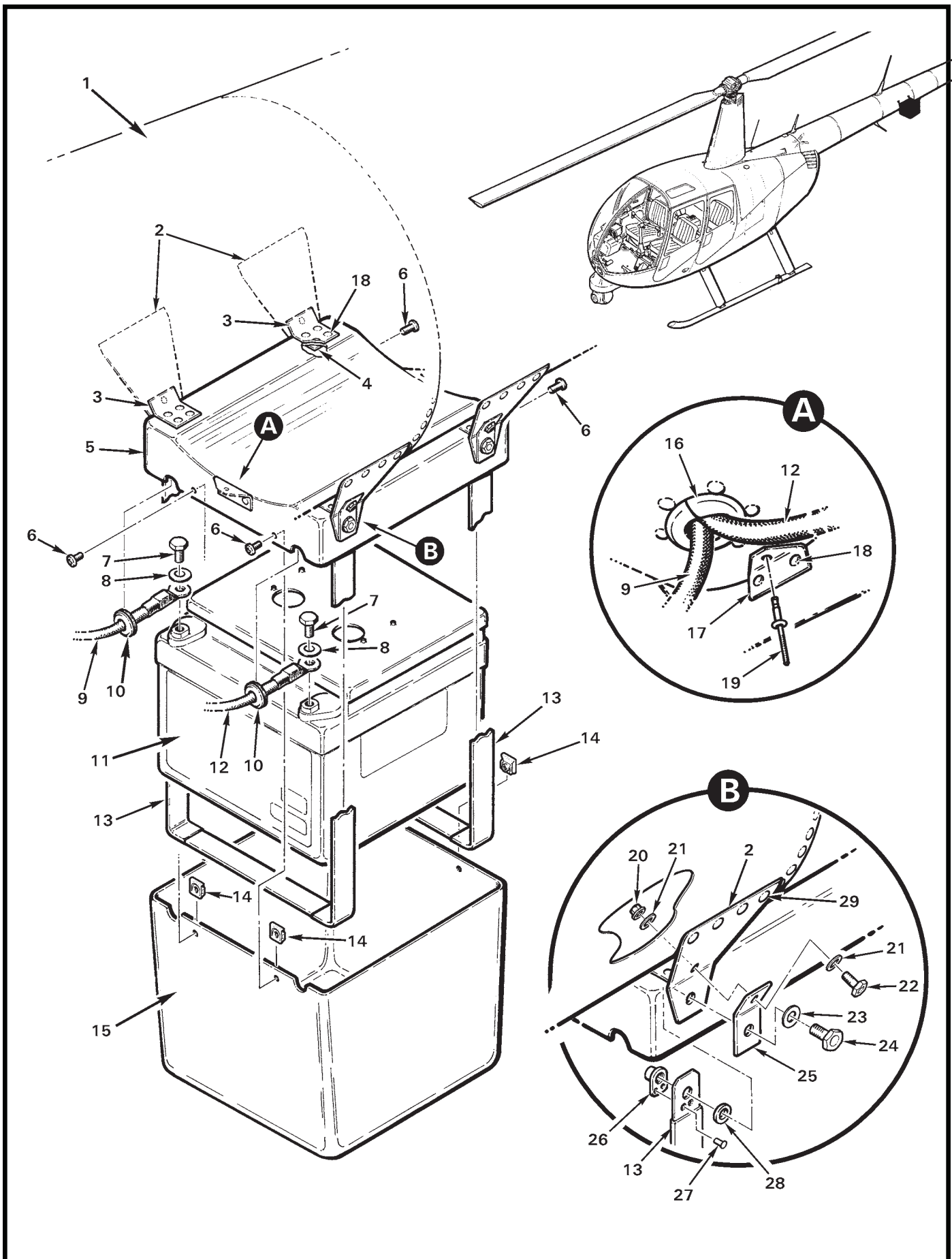

FIGURE AND INDEX NUMBER	PART NUMBER	DESCRIPTION	PARTS AVAIL	QTY PER ASSY
TAILCONE BATTERY INSTALLATION				
96-31-1	C023	Tailcone Assembly (Ref, see Figure 53-25)		
2	D362-7	Strap	X	4
3	D362-9	Angle	X	4
4	D362-5	Doubler	X	4
5	D361-5*	Cover Assembly (Ref; no longer available)		
6	MS27039C0806	Screw	X	4
7	—	Bolt (M8)	O	2
8	—	Washer (conical, M8)	O	2
9	A780-12	Cable Assembly - Battery Negative	X	1
10	MS35489-41X	Grommet	X	2
11	B237-4	Battery (Sealed case; 24-volt, includes items 7 and 8. Concord part no. RG24-15.)	X	1
12	A780-29	Cable Assembly - Battery Positive	X	1
13	D362-10	Strap Assembly (Incl items 26 and 27)	X	2
14	B162-2	Clipnut	X	4
15	D540-3	Box (Ref; no longer available)		
16	MS35489-19	Grommet	X	1
17	D362-6	Angle	X	2
18	MS20470AD4	Rivet	X	20
19	NAS9301B-4-02	Rivet	X	2
20	MS21042L3	Nut	X	4
21	NAS1149F0332P	Washer	X	8
22	NAS6603-3	Bolt	X	4
23	NAS1149F0432P	Washer	X	4
24	NAS6604-3	Bolt	X	4
25	D362-8	Angle	X	4
26	MS21086L4	Nutplate	X	4
27	NAS1097AD3	Rivet	X	8
28	A130-47	Spacer	X	4
29	NAS9301B-5-02	Rivet	X	16

NOTES * D361 Revision "F" and prior.

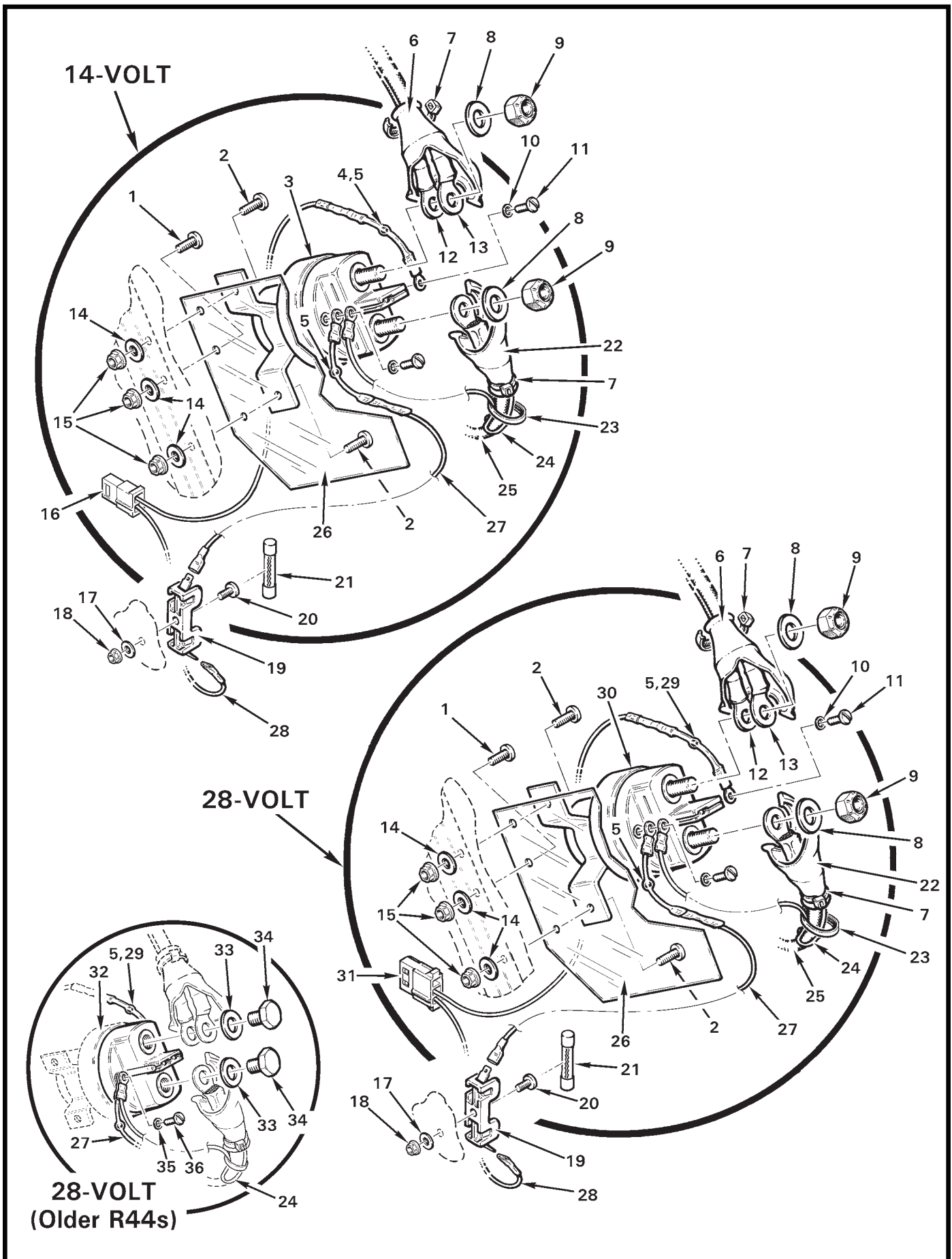

FIGURE AND INDEX NUMBER	PART NUMBER	DESCRIPTION	PARTS AVAIL	QTY PER ASSY
AFT BATTERY RELAY INSTALLATION*				
96-33-1	MS27039C1-06	Screw	X	1
2	MS27039C1-07	Screw	X	2
3	B415-1	Relay (14-volt; includes items 8 thru 11)	X	1
4	B304-4	Diode Assembly (14-volt; includes items 5, 16 thru 21, 27, and 28)	X	1
5	A15A	Diode (cover with B158-103 heat shrink)	X	2
	B158-103	Heat Shrink (0.187 in. dia., clear)	X	A/R
6	MS25171-4S	Nipple	X	1
7	MS3367-4-9	Ty-Rap	X	2
8	01000424	Washer (conical)	O	2
9	MS21044B5	Nut	O	2
10	01004635	Washer	O	2
11	01003621	Screw	O	2
12	A780-27	Cable (wire no. 580, to alternator shunt)	X	1
13	A780-26	Cable (wire no. 581, to starter)	X	1
14	NAS1149F0332P	Washer	X	3
15	MS21042L3	Nut	X	3
16	B263-13	Housing	X	1
	B263-2	Socket	X	2
17	NAS1149FN616P	Washer	X	1
18	MS21042L06	Nut	X	1
19	D262-1	Fuse Block (alternate part no. 354601)	X	1
20	MS35206-228	Screw	X	1
21	AGC-3	Fuse (3-amp)	X	1
22	MS25171-2S	Nipple	X	1
23	MS3367-4-9	Ty-Rap	X	A/R
24	A780-64	Wire (Ref)		
25	A780-25	Cable Assembly - Battery Positive (Includes item 24)	X	1
26	C452-3	Guard (clear plastic)	X	1
27	-65	Wire (Ref)		
28	-66	Wire (Ref)		

NOTES * Ship S/N 0945 and higher.

Continues

FIGURE AND INDEX NUMBER	PART NUMBER	DESCRIPTION	PARTS AVAIL	QTY PER ASSY
AFT BATTERY RELAY INSTALLATION* (Cont'd)				
96-33-29	B304-5	Diode Assembly (28-volt; includes items 5, 17 thru 21, 27, 28, and 31)	X	1
30	B415-2	Relay (28-volt; includes items 8 thru 11)	X	1
31	B263-15	Housing	X	1
	B263-2	Socket	X	2
32	26.57.01	Relay (Ref, 28-volt; for earlier R44s. To replace order item 30.)		
33	—	Washer (M8)	O	2
34	—	Bolt (M8 x 8)	O	2
35	—	Washer (M4)	O	2
36	—	Screw (M4 x 6)	O	2

NOTES * Ship S/N 0945 and higher.

Intentionally Blank

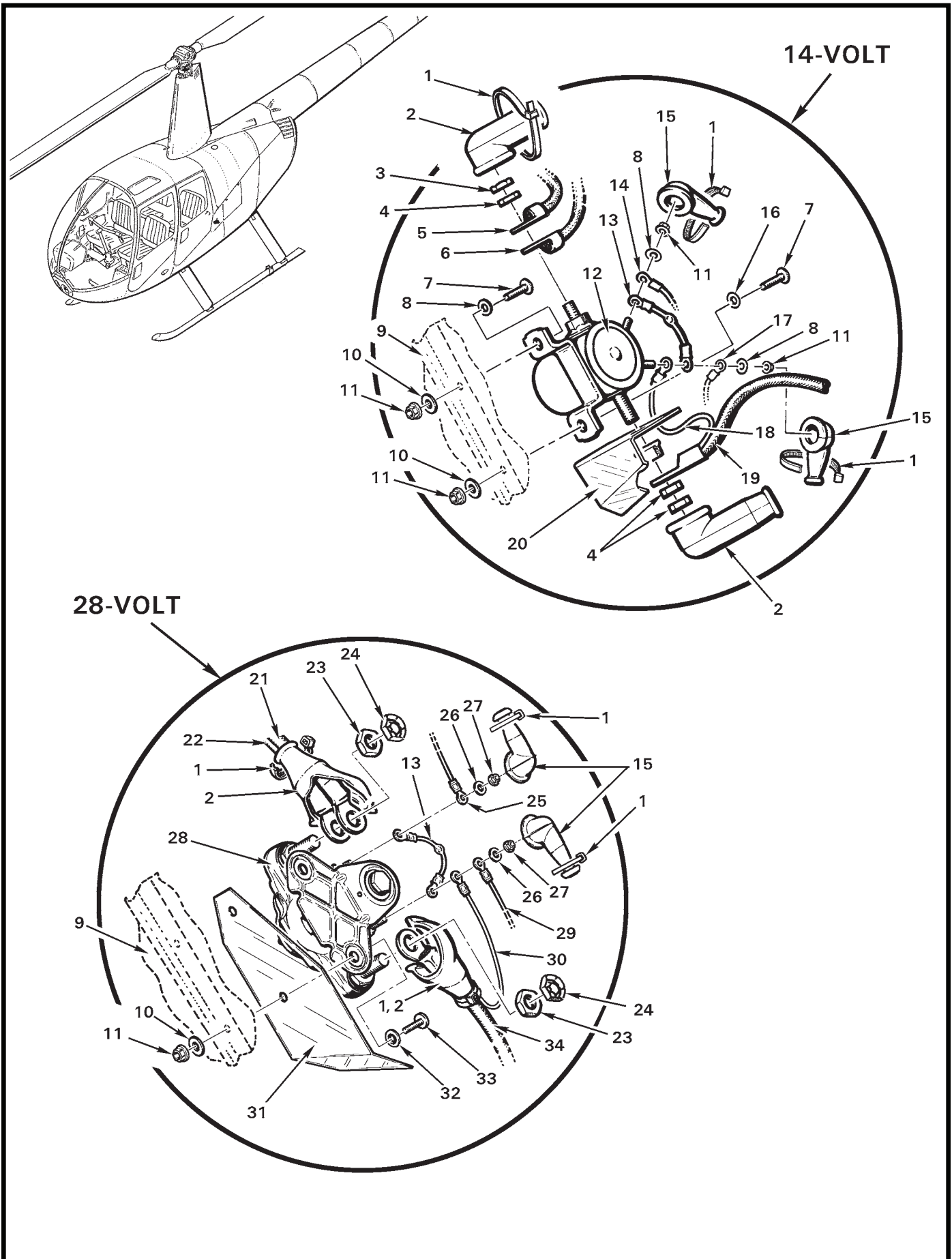

FIGURE AND INDEX NUMBER	PART NUMBER	DESCRIPTION	PARTS AVAIL	QTY PER ASSY
AFT BATTERY RELAY INSTALLATION				
96-37-1	MS3367-4-9	Ty-Rap	X	A/R
2	MS25171-4S	Nipple	X	2
3	B330-16	Palnut	X	1
4	AN316-5R	Nut	X	3
5	A780-9	Cable (wire no. 581, to starter)	X	1
6	C067-580	Cable (wire no. 580, to alternator shunt)	X	1
7	MS27039C1-07	Screw	X	2
8	NAS1149F0363P	Washer	X	2
9	C233-1	Vertical Firewall (Ref)		
10	NAS1149F0332P	Washer	X	2
11	MS21042L3	Nut	X	2
12	70-906*	Relay (14-volt, Ref)		
13	B304-2	Diode Assembly	X	1
14	B304-4	Diode Assembly (Wire no. 65. See also Figure 96-33.)	X	1
15	MS25171-1S	Nipple	X	2
16	A141-17	Washer	X	2
17	B304-4	Diode Assembly (Ref, wire no. 66)	X	1
18	A780-64	Wire (Ref)		
19	A780-8	Cable Assembly - Battery Positive (Include item 18)	X	1
20	C452-1	Guard	X	2
* * *				
21	A780-15**	Cable Assembly (Ref)		
22	A780-16**	Cable Assembly (Ref)		
23	AN316-6R	Nut	X	2
24	B330-19	Palnut	X	2
25	B304-5	Diode Assembly (Wire no. 65. See also Figure 96-33.)	X	1
26	NAS1149FN616P	Washer	X	2
27	MS21042L06	Nut	X	2
28	6041H202*	Relay (28-volt, Ref)		
29	B304-5	Diode Assembly (Wire no. 66. See also Figure 96-33.)	X	1
30	A780-64	Wire (Ref)		

NOTES * Ship S/N 0001 thru 0944.
 ** No longer available. Refer to R44 SL-23.

Continues

FIGURE AND INDEX NUMBER	PART NUMBER	DESCRIPTION	PARTS AVAIL	QTY PER ASSY
AFT BATTERY RELAY INSTALLATION* (Cont'd)				
96-37-31	C452-2	Guard	X	2
32	5745-PH-248-027-194	Shoulder Washer	X	2
33	MS27039C1-07	Screw	X	2
	B270-4	Sealant (for bottom screw head)	X	A/R
34	A780-14	Cable Assembly - Battery Positive (Incl item 30)	X	1

NOTES * Ship S/N 0001 thru 0944.

Intentionally Blank

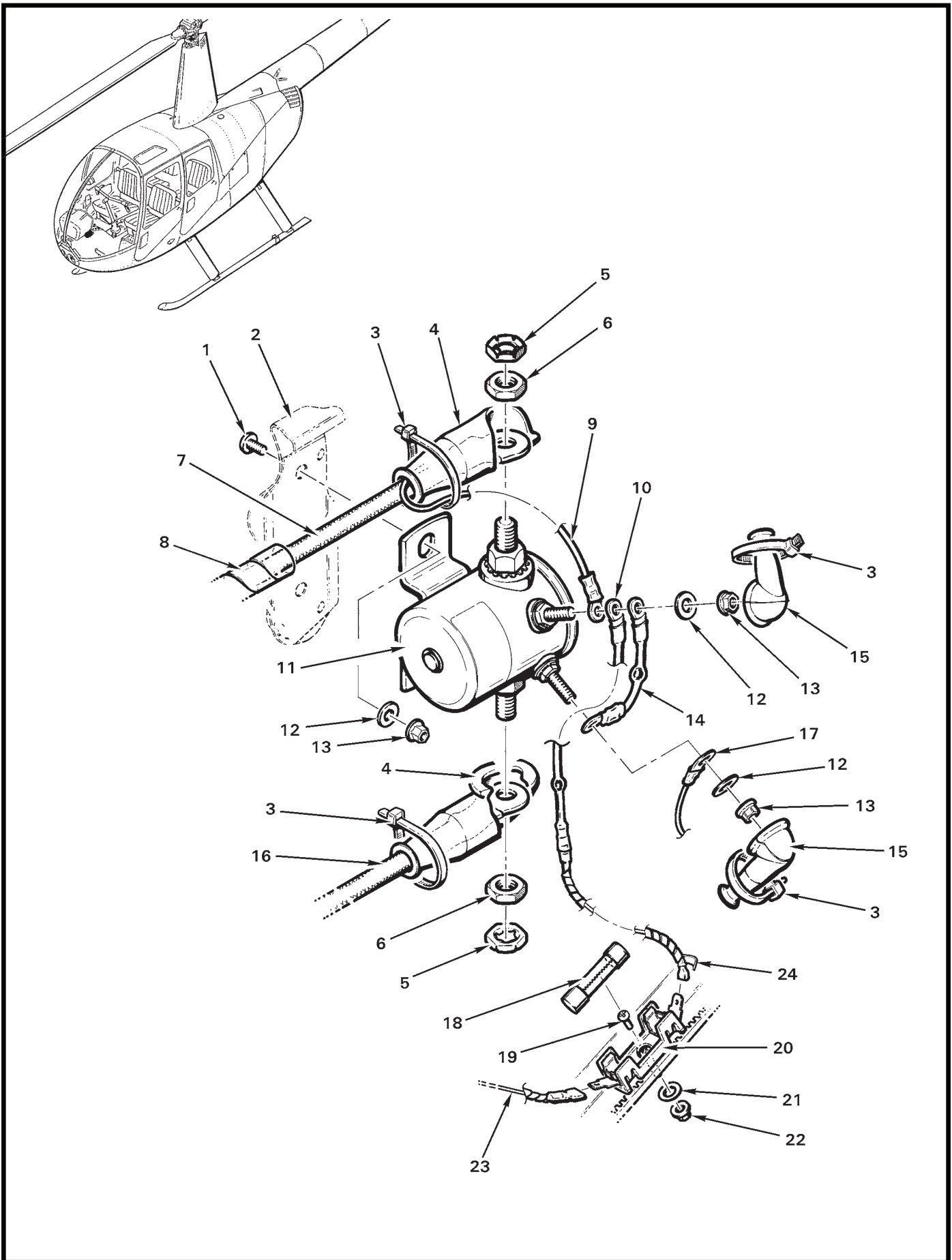

FIGURE AND INDEX NUMBER	PART NUMBER	DESCRIPTION	PARTS AVAIL	QTY PER ASSY
		NOSE BATTERY RELAY (14V)*		
96-41-31	MS27039C1-06	Screw	X	2
2	C359-2	Console Panel (Ref)		
3	MS3367-4-9	Ty-Rap	X	4
4	MS25171-2S	Nipple	X	2
5	B330-16	Palnut	X	2
6	AN316-5R	Nut	X	2
7	A780-6	Cable Assembly - Battery Positive (Incl item 9)	X	1
8	B161-8	Spirap	X	A/R
9	A780-64	Wire (Ref)		
10	B304-3	Diode Assembly (Includes A15A diode and items 18 thru 22) . .	X	1
11	70-906**	Relay (14-volt, Ref)		
12	NAS1149F0363P	Washer	X	4
13	MS21042L3	Nut	X	4
14	B304-2	Diode Assembly	X	1
15	MS25171-1S	Nipple	X	2
16	C067-587	Cable (to starter)	X	1
17	C059-141	Wire (Ref)		
18	AGC-3	Fuse (3-amp)	X	1
19	MS35206-228	Screw	X	1
20	354601	Fuse Block	X	1
21	NAS1149FN616P	Washer	X	1
22	MS21042L06	Nut	X	1
23	C059-142	Wire (Ref)		
24	B161-2	Spirap	X	A/R

NOTES * Ship S/N 0001 thru 0944, no longer available.
 ** Order KI-153 kit to replace relay (see Figure 96-19, item 51).

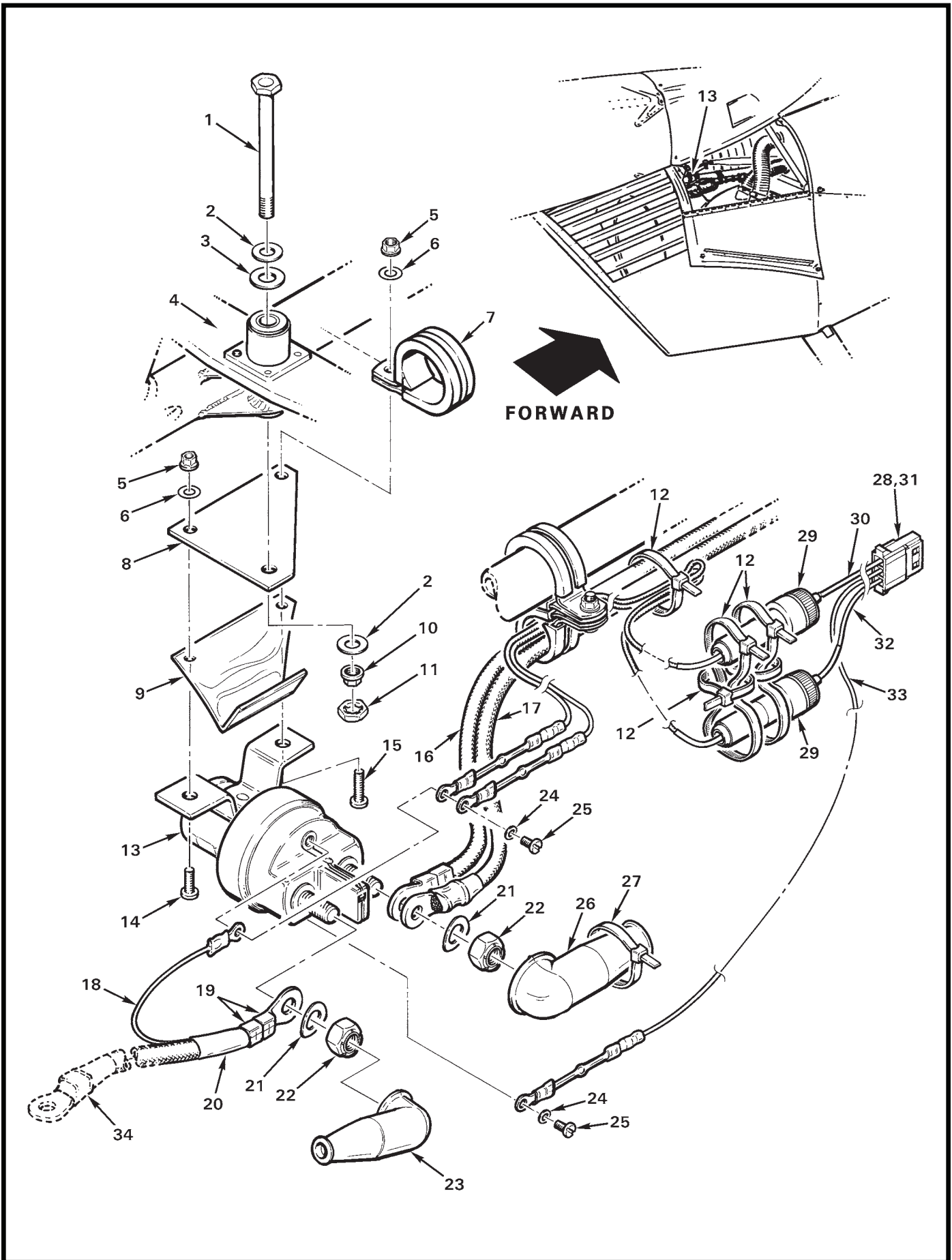

FIGURE AND INDEX NUMBER	PART NUMBER	DESCRIPTION	PARTS AVAIL	QTY PER ASSY
TAILCONE BATTERY RELAY INSTALLATION				
96-43-1	NAS6604-37	Bolt	X	1
2	NAS1149F0432P*	Washer (Ref)		
3	A141-3*	Washer (Ref)		
4	A331-4*	Bellcrank – Tail Rotor Control (Ref)		
5	MS21042L3	Nut	X	2
6	NAS1149F0332P	Washer	X	2
7	MS21919WDG16	Clamp	X	1
8	D399-9	Tab	X	1
9	D399-7	Shield	X	1
10	D210-4*	Nut (Ref)		
11	B330-13*	Palnut (Ref)		
12	MS3367-5-9	Ty-Rap	X	A/R
13	B415-2	Relay (Incl items 21, 22, 24, and 25)	X	1
14	MS27039C1-07	Screw	X	1
15	MS27039C1-09	Screw	X	1
16	A780-24	Cable Assembly	X	1
17	A780-28	Cable Assembly	X	1
18	-64	Wire (Ref)		
19	B260-20	Terminal	X	2
20	B158-8	Heat Shrink	X	A/R
21	01000424	Washer (conical)	X	2
22	MS21044B5	Nut	X	2
23	MS25171-2S	Nipple	X	1
24	01004635	Washer	X	2
25	01003621	Screw	X	2
26	MS25171-4S	Nipple	X	1
27	MS3367-4-9	Ty-Rap	X	1
28	B304-7	Diode Assembly (Includes items 29 thru 33, terminals, heat shrink, and splices as an assembled unit.)	X	1
29	15502	Fuse Holder	X	2
	AGC-3	Fuse (3-amp)	X	2
30	-66	Wire (Ref, housing slot no. 1)		

NOTES * See Figure 67-91.

Continues

FIGURE AND INDEX NUMBER	PART NUMBER	DESCRIPTION	PARTS AVAIL	QTY PER ASSY
TAILCONE BATTERY RELAY INSTALLATION (Cont'd)				
96-43-31	B263-15	Housing	X	1
	B263-2	Socket	X	3
32	-1226	Wire (Ref, housing slot no. 3)		
33	-65	Wire (Ref, housing slot no. 2)		
34	A780-29	Cable Assembly – Battery Positive (Ref, see Figure 96-31. Does not include items 18, 19, or 20.)		
NOTES				

Intentionally Blank

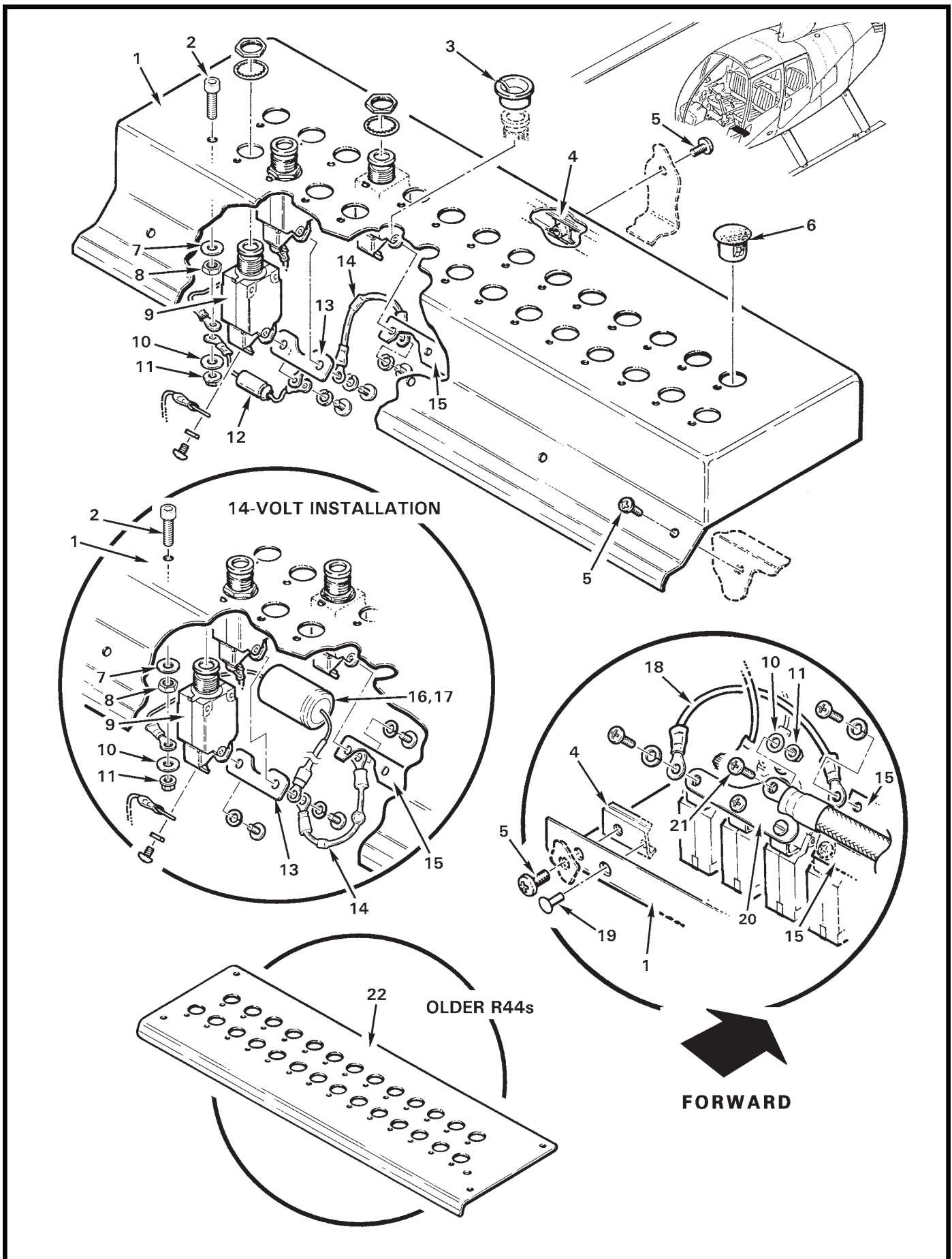

FIGURE AND INDEX NUMBER	PART NUMBER	DESCRIPTION	PARTS AVAIL	QTY PER ASSY
		CIRCUIT BREAKER PANEL		
96-47-1	C490-8	Circuit Breaker Panel Assembly (28 holes, 14/28-volt ships with hydraulic flight controls. Includes items 4 and 19.)	X	1
2	NAS1352-08-10P	Screw	X	1
3	10164-5	Button (red; for "Clutch/Start" breaker)	X	1
4	A738-11	Gang Channel	X	1
5	MS27039C0806	Screw	X	10
6	2633	Hole Plug	X	A/R
7	NAS1149DN832H	Washer (aluminum)	X	1
8	AN340-8	Nut	X	1
9	B297-2	Circuit Breaker (2-amp)	X	A/R
	B297-5	Circuit Breaker (5-amp)	X	A/R
	B297-7	Circuit Breaker (7 1/2-amp; "COM" breaker on earlier R44s)	X	A/R
	B297-10	Circuit Breaker (10-amp)	X	A/R
	B297-20	Circuit Breaker (20-amp)	X	A/R
10	NAS1149FN816P	Washer	X	2
11	MS21042L08	Nut	X	2
12	B304-1	Capacitor Assembly (28-volt, IO-540 ships)	X	1
13	A448-3	Bus Bar (2 breakers)	X	1
14	A045-2	Diode Assembly	X	1
15	A448-1	Bus Bar (6 breakers)	X	A/R
	A448-4	Bus Bar (3 breakers)	X	A/R
	A448-9	Bus Bar (9 breakers)	X	A/R
	A448-10	Bus Bar (4 breakers)	X	A/R
	A448-14	Bus Bar (8 breakers)	X	A/R
16	B304-11	Capacitor Assembly (14-volt, O-540 ships. Install using item 17.)	X	1
17	B270-13	Sealant (clear)	X	A/R
18	C059-102	Jumper Wire (Ref)		
19	MS20426AD3	Rivet	X	3
20	A448-16	Bus Bar (with power tab)	X	1
21	MS27039C0805	Screw	X	1
22	C490-1	Circuit Breaker Panel (27 holes, ship S/N 0001 thru 0270) . . .	X	1
	C490-7	Circuit Breaker Panel Assembly (28 holes, 14-volt ships with manual flight controls. Includes items 4 and 19; not shown.)	X	1
	C490-9	Circuit Breaker Panel Assembly (28 holes, 28-volt ships with manual flight controls. Includes items 4 and 19; not shown.)	X	1

NOTES

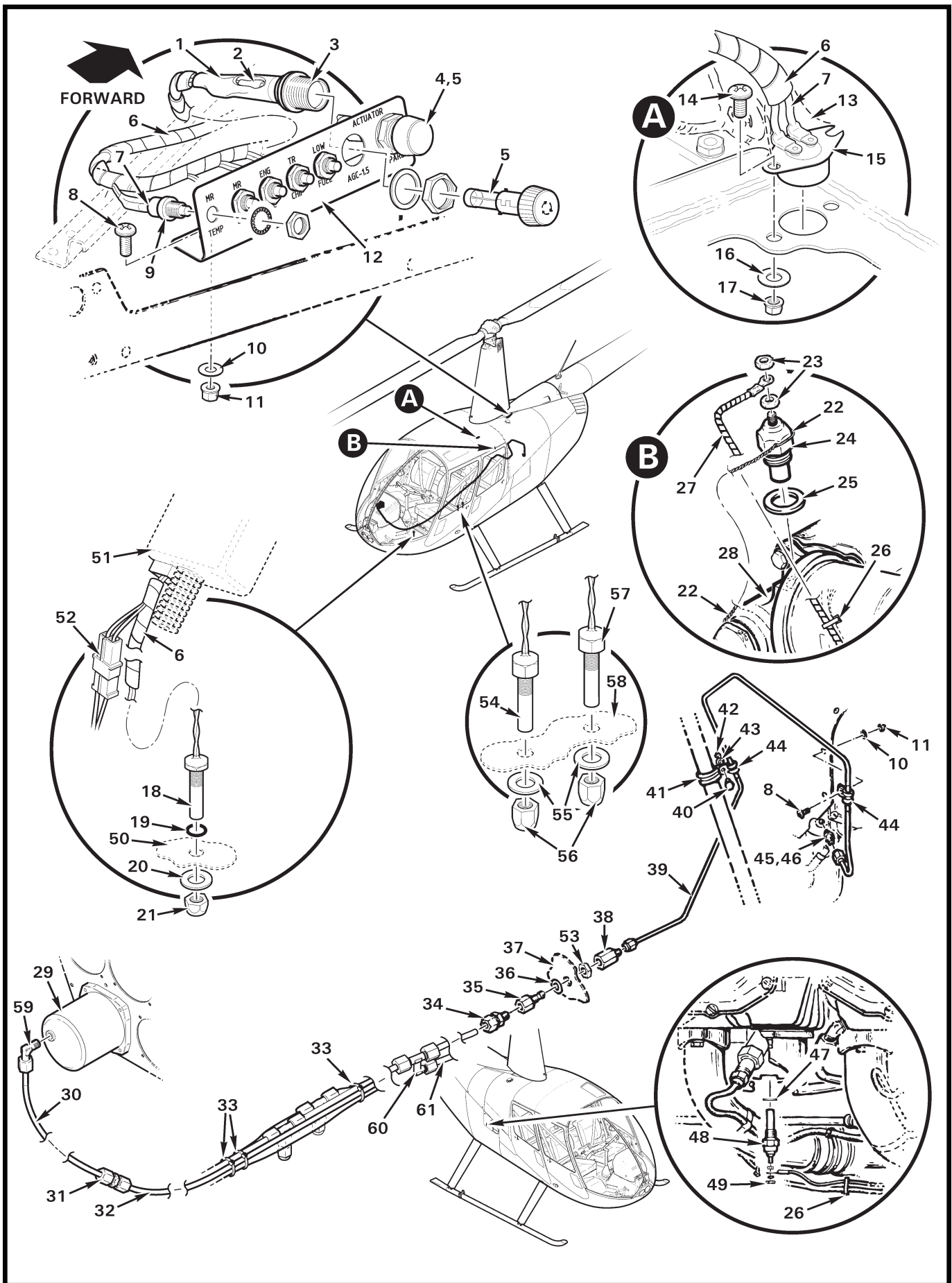

FIGURE AND INDEX NUMBER	PART NUMBER	DESCRIPTION	PARTS AVAIL	QTY PER ASSY
TEST SWITCHES AND GAGE PROBES*				
96-49-1	B158-8	Heat Shrink (around fuse holder)	X	A/R
2	B158-3	Heat Shrink (around wires)	X	A/R
3	D262-11	Fuse Holder (clutch actuator; includes washer and nut)	X	1
4	D262-11	Fuse Holder (spare; includes washer and nut)	X	1
5	D275-203	Fuse (3-amp, 14-volt ships; AGC-3-R)	X	2
	AGC-1-1/2-R	Fuse (1.5-amp, 28-volt ships)	X	2
6	B161-4	Spirap	X	A/R
7	B158-2	Heat Shrink	X	A/R
8	MS27039C0806	Screw	X	3
9	B227-1	Switch – Test (includes washer and nut)	X	5
10	NAS1149FN816P	Washer	X	3
11	MS21042L08	Nut	X	3
12	A938-3	Mount	X	1
13	B270-1	Sealant	X	A/R
14	MS51957-27	Screw	X	2
15	A688-2	Switch – Fire Detection (includes terminals)	X	1
16	NAS1149FN616P	Washer	X	2
17	MS21042L06	Nut	X	2
18	B341-4	Probe Assembly – Outside Air Temperature (includes items 19 thru 21 and item 52)	X	1
19	—	O-Ring	O	1
20	—	Washer	O	1
21	—	Nut	O	1
22	MS20995C32	0.032 in. dia. Safety Wire	O	A/R
23	—	Nut	O	2
24	A760-1	Oil Temperature Sender (Single; includes items 23 and 25. Used with B144-3 instrument cluster on 14-volt ships, and B144-4 instrument cluster on 28-volt ships.)	X	1
	A760-3	Oil Temperature Sender (Dual; includes items 23 and 25. Used with B144-5 10- to 32-volt instrument cluster and D270-1 governor controller.)	X	1
25	15-724**	Gasket	X	1
26	MS3367-4-9	Ty-Rap	X	A/R

NOTES * Ship S/N 0001 thru 9999.
 ** Rochester Gauges part no.

Continues

FIGURE AND INDEX NUMBER	PART NUMBER	DESCRIPTION	PARTS AVAIL	QTY PER ASSY
TEST SWITCHES AND GAGE PROBES* (Cont'd)				
96-49-27	B161-2	Spirap	X	A/R
28	D723	Oil Filter Adapter (Ref)		
29	A600-4	Manifold Pressure Gage (Ref; R44 I O-540 engine, see Figure 95-1)		
	A600-6	Manifold Pressure Gage (Ref; R44 II IO-540 engine, see Figure 95-1)		
	A600-7	Manifold Pressure Gage (Ref; R44 Cadet O-540 engine, see Figure 95-1)		
30	A729-52	Tube	X	1
31	15-4-N-0	Union	X	1
32	A729-15	Tube	X	1
33	MS3367-5-9	Ty-Rap (or MS3367-5-9)	X	A/R
34	10-4-2-N-0	Fitting (install using item 46)	X	1
35	A457-14	Bulkhead Adapter (includes item 53; or O253-2-4)	X	1
36	NAS1149F0732P	Washer	X	2
37	C233-1	Firewall (Ref)		
38	AN894D4-3	Bushing	X	1
39	C740-1	Manifold Pressure Line	X	1
40	AN3-3A	Bolt	X	1
41	MS21919WDG14	Clamp	X	1
42	MS21042L3	Nut	X	1
43	NAS1149F0332P	Washer	X	1
44	MS21919WDG3	Clamp	X	2
45	AN816-3D	Nipple (install using item 46)	X	1
46	B270-6	Sealant (for pipe threads)	X	A/R
47	—	Gasket	O	1
48	A760-2	Sender – Cylinder Head Temperature (Located at no. 2 cylinder, or no. 5 w/AC installed**; includes item 47, and nuts. For use with B144-5 [10- to 32-volt] instrument cluster.)	X	1
	3080-38	Sender – Cylinder Head Temperature (Located at no. 2 cylinder, or no. 5 w/AC installed**; includes item 47, and nuts. For use with B144-3 [14-volt] or B144-1 [28-volt] instrument cluster.)	X	1

NOTES * Ship S/N 0001 thru 9999.
 ** Ship S/N 30001 and subsequent.

Continues

FIGURE AND INDEX NUMBER	PART NUMBER	DESCRIPTION	PARTS AVAIL	QTY PER ASSY
TEST SWITCHES AND GAGE PROBES* (Cont'd)				
96-49-49	B330-2	Palnut	X	1
50	C272-1	Chin (Ref)		
51	B341-1	Gauge – Outside Air Temperature (Ref)		
52	B263-12	Housing	X	1
50	C272-1	Chin (Ref)		
51	B341-4	Gage – Outside Air Temperature (Ref)		
52	B263-12	Housing	X	1
	B263-1	Pin	X	2
53	—	Nut	O	1
54	A760-4	Sender – Outside Air Temperature (Incl items 55 thru 57) . . .	X	1
55	—	Washer (teflon coated)	O	1
56	—	Nut	O	1
57	GTP59*	Sender – Outside Air Temperature (Incl items 55 and 56)	X	1
58	C392	Belly Panel (Ref)		
59	40-4-2-N-O	Elbow	X	1
60	60-4-2-N-O	Tee	X	1
	45-4-2-N-O	Elbow	X	1
61	A729-24	Tube (to D270-1 governor controller/data recorder; see Figure 96-63)	X	1

NOTES * Garmin part number.

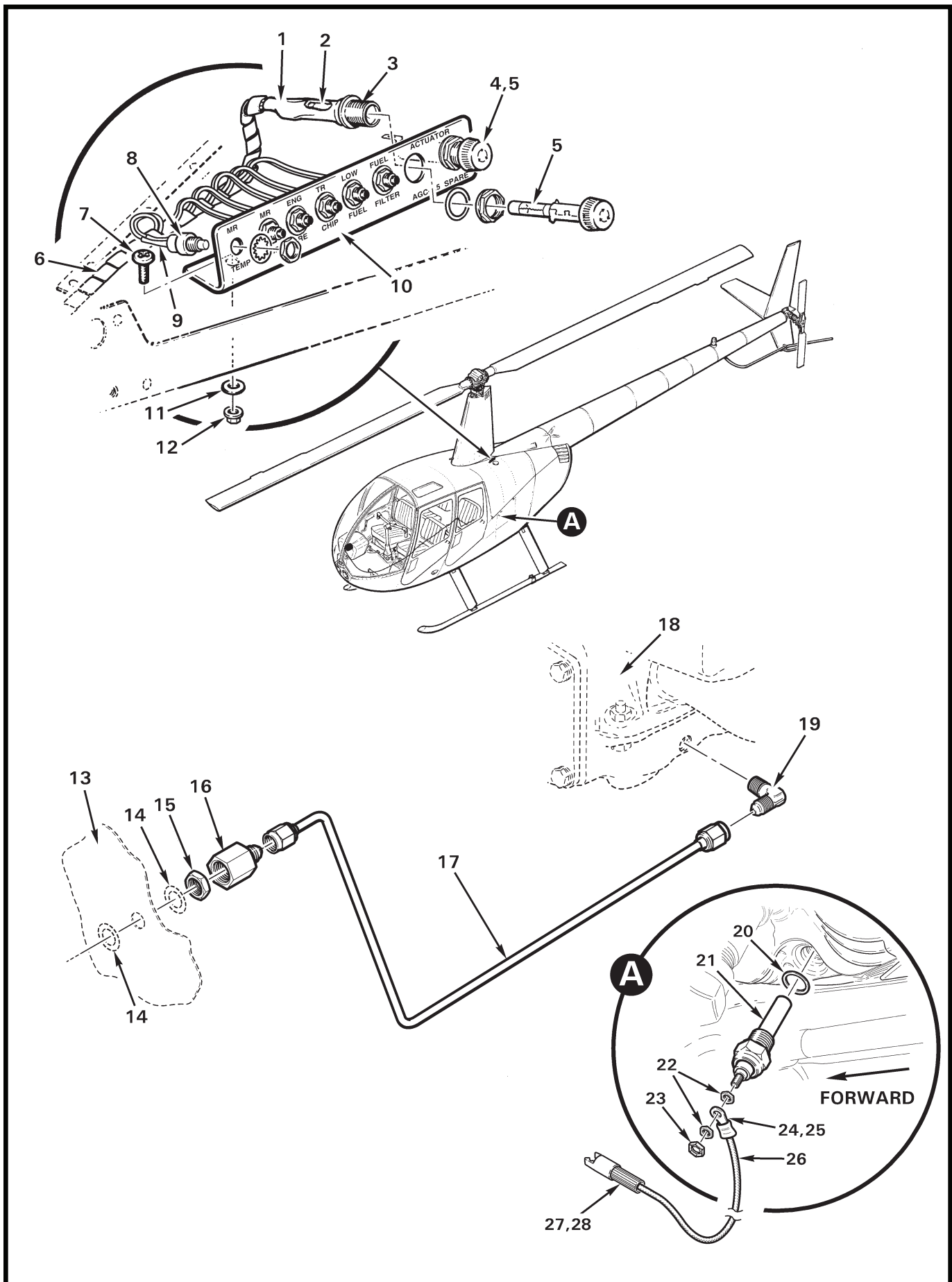

FIGURE AND INDEX NUMBER	PART NUMBER	DESCRIPTION	PARTS AVAIL	QTY PER ASSY
TEST SWITCHES AND GAGE PROBES*				
96-53-1	B158-6	Heat Shrink (around fuse holder)	X	A/R
2	B158-3	Heat Shrink (around wires)	X	A/R
3	D262-11	Fuse Holder (clutch actuator)	X	1
4	D262-11	Fuse Holder (spare)	X	1
5	AGC-1.5	Fuse (1.5-amp)	X	2
6	B161-4	Spirap	X	A/R
7	MS27039C0806	Screw	X	2
8	B227-1	Switch – Test (includes washer and nut)	X	6
9	B158-2	Heat Shrink	X	A/R
10	A938-5	Mount	X	1
11	NAS1149FN816P	Washer	X	3
12	MS21042L08	Nut	X	3
13	—	Firewall – Vertical (Ref)		
14	NAS1149F0732P	Washer** (Ref)		
15	—	Nut** (Ref)		
16	AN894D4-3	Bushing** (Ref)		
17	D740-1	Line Assembly – Manifold Pressure	X	1
18	—	Engine (Ref)	X	1
19	MS20822-3D	Elbow	X	1
20	—	Gasket (supplied with item 21)	O	1
21	A760-2	Sender – Cylinder Head Temperature (Located at no. 5 cylinder; includes items 20 and 22. For use with B144-5 (10- to 32-volt) instrument cluster.)	X	1
	3080-38	Sender – Cylinder Head Temperature (Located at no. 5 cylinder, includes items 20 and 22. For use with B144-3 (14-volt) or B144-1 (28-volt) instrument cluster.)	X	1
22	—	Nut	O	A/R
23	B330-2	Palnut	X	1
24	C049-7	Harness Assy. (Incl items 25 thru 28. Assembled as shown.)	X	1
25	B260-10	Terminal	X	1
26	—	Wire (Ref)		
27	B263-10	Housing	X	1
28	B263-1	Pin	X	1

NOTES * Ship S/N 10001 and subsequent.
 ** See also Figure 95-51.

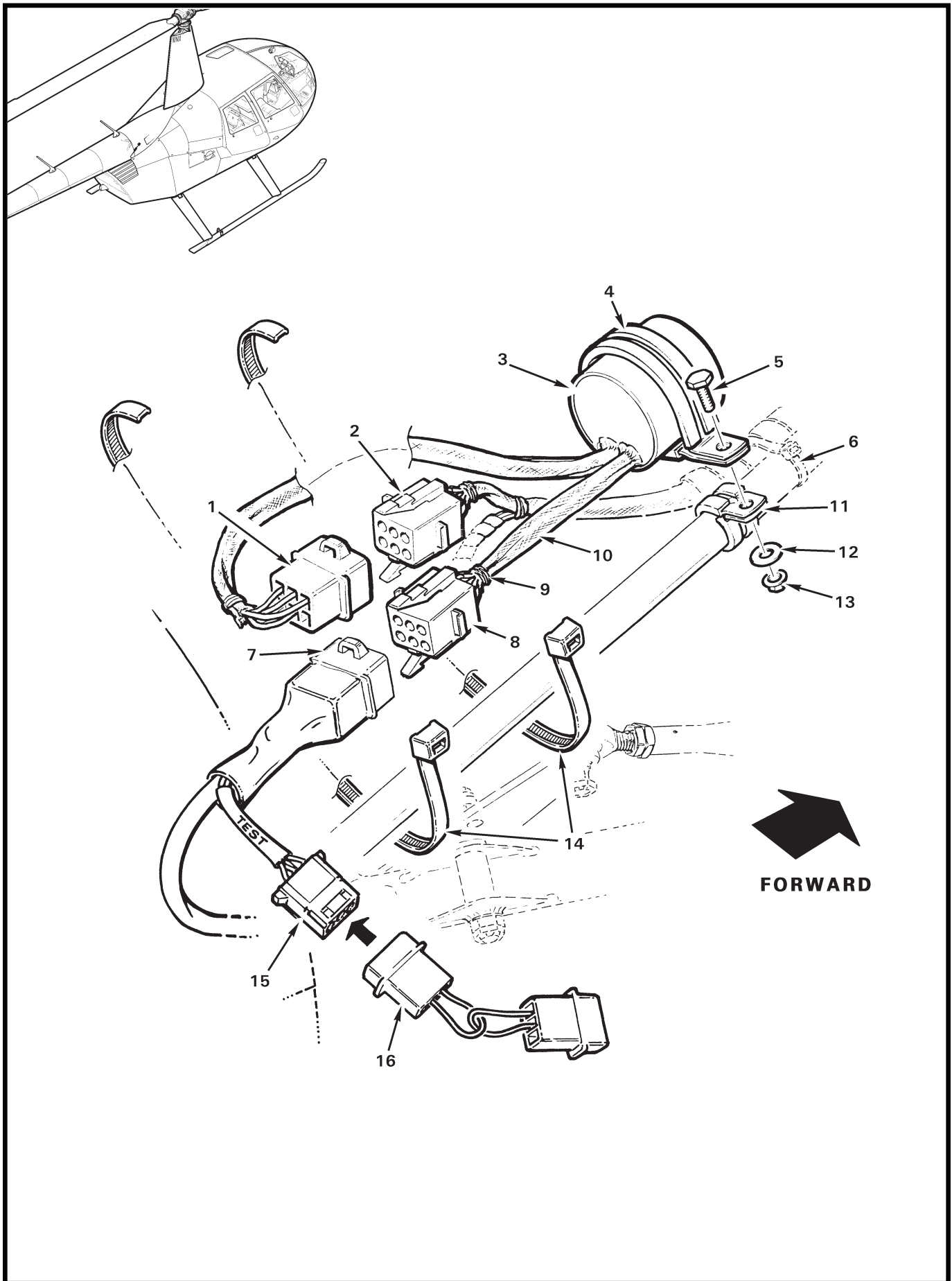

FIGURE AND INDEX NUMBER	PART NUMBER	DESCRIPTION	PARTS AVAIL	QTY PER ASSY
		BELT TENSION ACTUATOR TIME DELAY AND TEST PLUG		
96-55-1	B263-18	Housing	X	1
	B263-1	Pin	X	5
2	B263-19	Housing (Ref, airframe harness)	X	1
	B263-4	Socket	X	5
3	D602-1	Time Delay Assembly - Belt Tension Actuator (Incl items 1, and 8 thru 10)	X	1
4	MS21919WDG20	Clamp	X	1
5	AN3-4A	Bolt	X	1
6	MS3367-5-9	Ty-Rap (Ref)	X	1
7	B263-18	Housing (6-pin)	X	1
	B263-1	Pin (not shown)	X	1
	B263-3	Pin (not shown)	X	4
	A15A	Diode (between pins 3 and 5)	X	1
8	B263-19	Housing	X	1
	B263-2	Socket	X	5
9	B268-3	Tape - Lacing	X	2
10	B266-4	Sleeving (expandable)	X	2
11	MS21919WDG10	Clamp	X	1
12	NAS1149F0332P	Washer	X	4
13	MS21042L3	Nut	X	1
14	MS3367-7-9	Ty-Rap	X	1
		X	1
15	B263-15	Housing	X	1
	B263-2	Socket	X	2
	B263-4	Socket	X	1
16	MT558-1	Actuator Test Plug Assembly	X	1

NOTES

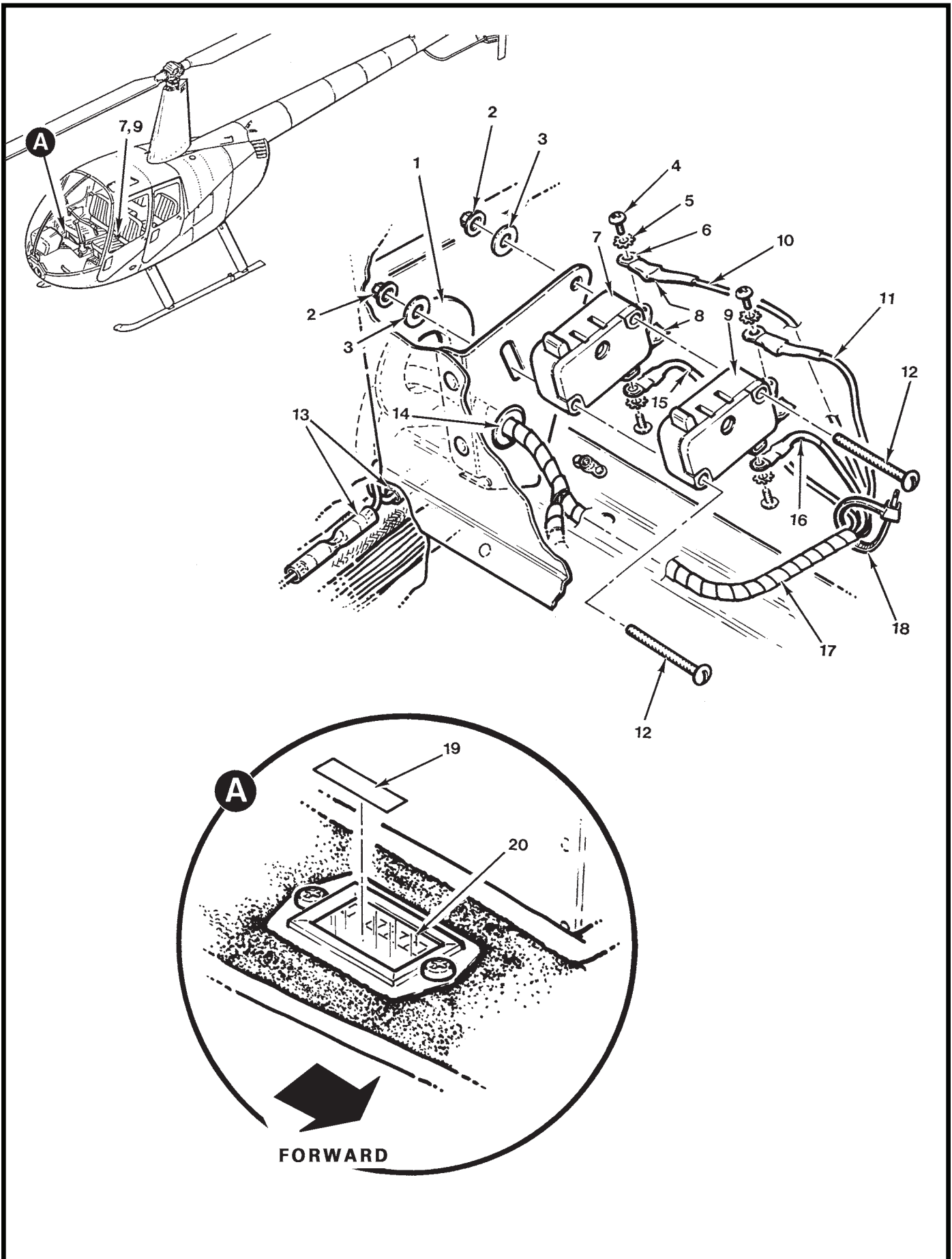

FIGURE AND INDEX NUMBER	PART NUMBER	DESCRIPTION	PARTS AVAIL	QTY PER ASSY
COLLECTIVE-ACTIVATED SWITCH INSTALLATION				
96-57-1	MS35489-19	Grommet	X	1
2	MS21042L04	Nut	X	2
3	NAS1149FN416P	Washer	X	2
4	—	Screw	O	3
5	—	Washer	O	3
6	B260-2	Terminal (4 places)	X	4
7	V3-1	Switch - Micro (Low RPM warning; includes items 4 and 5.) . . .	X	1
8	B158-6	Heat Shrink	1	A/R
9	V3-1	Switch - Micro (Hourmeter, includes items 4 and 5.)	X	1
10	-76	Wire (Ref)		
11	-751	Wire (Ref)		
12	MS35206-222	Screw	X	2
13	B261-2	Splice (used only with item 21)	X	2
14	MS35489-4	Grommet	X	1
15	-75	Wire (Ref)		
16	-750	Wire (Ref)		
17	B161-2	Spirap	X	A/R
18	MS3367-4-9	Ty-Rap	X	1
19	B387-3	Decal - "Collective Activated"	X	1
20	D830-2	Hourmeter (Ref, see Figure 95-5)		
* * *				
21	KI-108	Collective-Activated Hourmeter Switch Installation Kit (Includes items 2, 3, 8, 9, 12, 13, 18, 19, 22, and 23)	X	1
22	B387-750	Wire (includes wire and item 6 [1])	X	1
23	B387-751	Wire (includes wire and item 6 [1])	X	1

NOTES

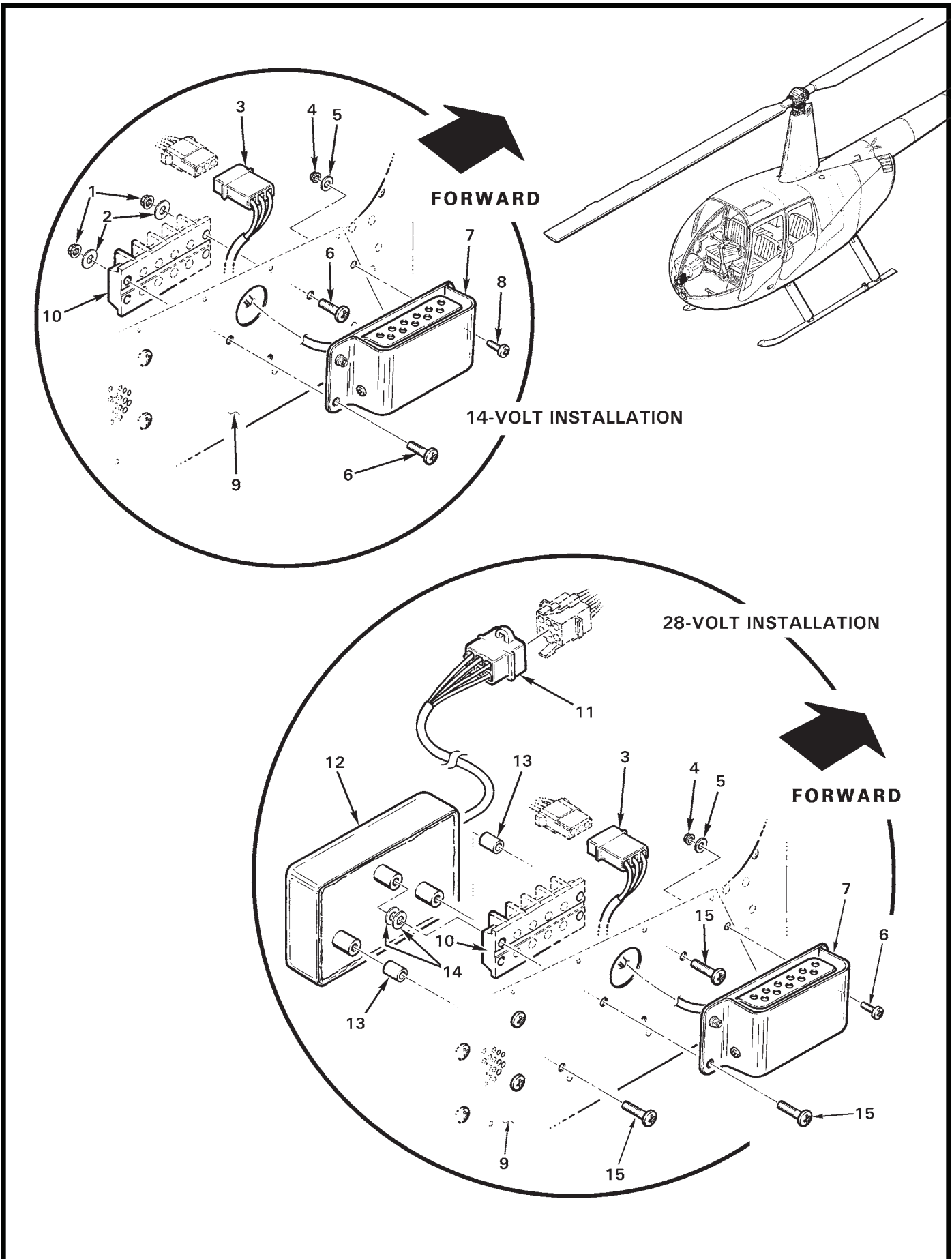

FIGURE AND INDEX NUMBER	PART NUMBER	DESCRIPTION	PARTS AVAIL	QTY PER ASSY
CARBON MONOXIDE DETECTOR AND DIMMER INSTALLATION				
96-59-1	MS21042L06	Nut	X	2
2	NAS1149FN616P	Washer	X	2
3	B263-14	Housing	X	2
	B263-1	Pin	X	2
4	MS21042L04	Nut	X	1
5	NAS1149FN416P	Washer	X	1
6	MS35206-232	Screw	X	2
7	C696-1	Carbon Monoxide Detector Assembly (Incl item 3)	X	1
8	MS35206-215	Screw	X	1
9	—	Panel - Upper Console (RH, Ref)		
10	601716-4	Terminal Block (Ref)		
11	B263-18	Housing	X	1
	B263-1	Pin	X	6
12	B395-1*	Dimmer Assembly (panel lamp; includes item 11)	X	1
13	A130-34*	Spacer	X	2
14	NAS1149FN816P*	Washer	X	2
15	MS27039C0810*	Screw	X	3

NOTES * 28-volt ships only.

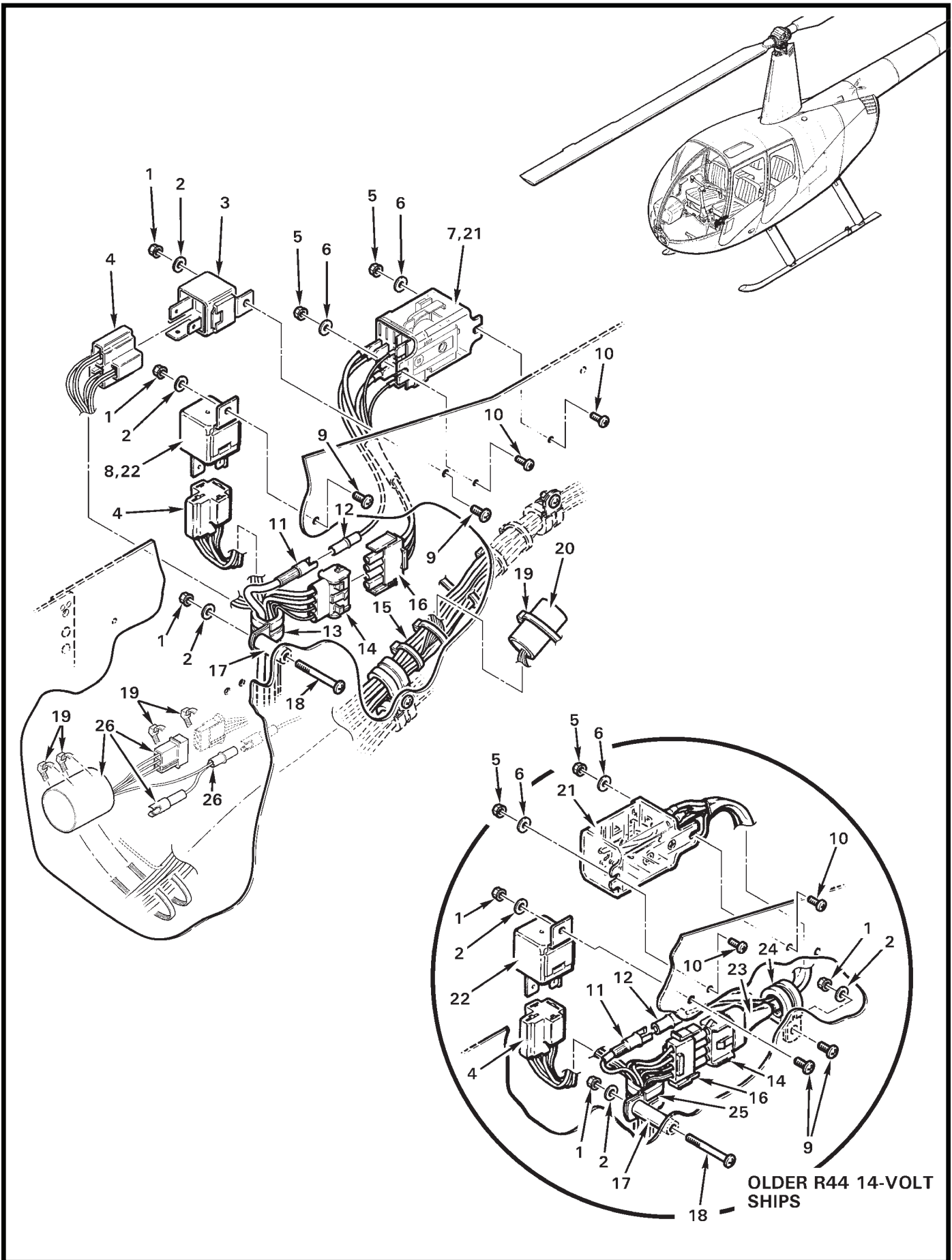

FIGURE AND INDEX NUMBER	PART NUMBER	DESCRIPTION	PARTS AVAIL	QTY PER ASSY
ELECTRICAL COMPONENTS				
96-61-1	MS21042L08	Nut	X	3
2	NAS1149FN816P	Washer	X	3
3	VF7-41H11	Relay - Fuel Pump (ship S/N 10001 and higher, this location)	X	1
4	VCF7-1000	Connector	X	1
	B262-6	Receptacle (small)	X	2
	B262-7	Receptacle (large)	X	2
5	MS21042L06	Nut	X	2
6	NAS1149FN632P	Washer	X	2
7	A999-4	Master Radio Relay Assembly (28-volt ships; Incl items 12 and 16)	X	1
8	VF7-41H11	Relay - Landing Light (28-volt ships)	X	1
9	MS27039C0806	Screw	X	2
10	MS35206-228	Screw	X	2
11	B263-10	Housing	X	1
	B263-1	Pin	X	1
12	B263-11	Housing	X	1
	B263-2	Socket	X	1
13	MS21919WDG8	Clamp (WDG9 or WDG10, as required to secure wire bundle)	X	1
14	B263-68	Housing	X	1
	B263-52	Socket	X	2
	B263-56	Socket	X	2
15	C059	Harness Assembly (Ref)		
16	B263-67	Housing	X	1
	B263-51	Pin	X	2
	B263-55	Pin	X	2
17	C130-17	Spacer (upper aft position shown)	X	4
18	MS27039C0822	Screw (upper aft position shown)	X	4
19	MS3367-5-9	Ty-Rap	X	A/R
20	D767-1	Logic Module Assembly - Fuel Pump	X	1
21	A999-3	Master Radio Relay Assembly (14-volt ships; Incl items 12, 14, and 23)	X	1
22	VF7-41F11	Relay - Landing Light (14-volt ships)	X	1
23	B158-12	Heat Shrink	X	A/R
24	MS21919WDG7	Clamp	X	1
25	MS21919WDG8	Clamp	X	1
26	D880-1 *	Time Delay Assembly - Ignition Starting (assembled as shown)	X	1

NOTES * Ship S/N 10001 and higher only. Refer to R44 Service Letter R44 SL-42 to upgrade earlier R44 IIs.

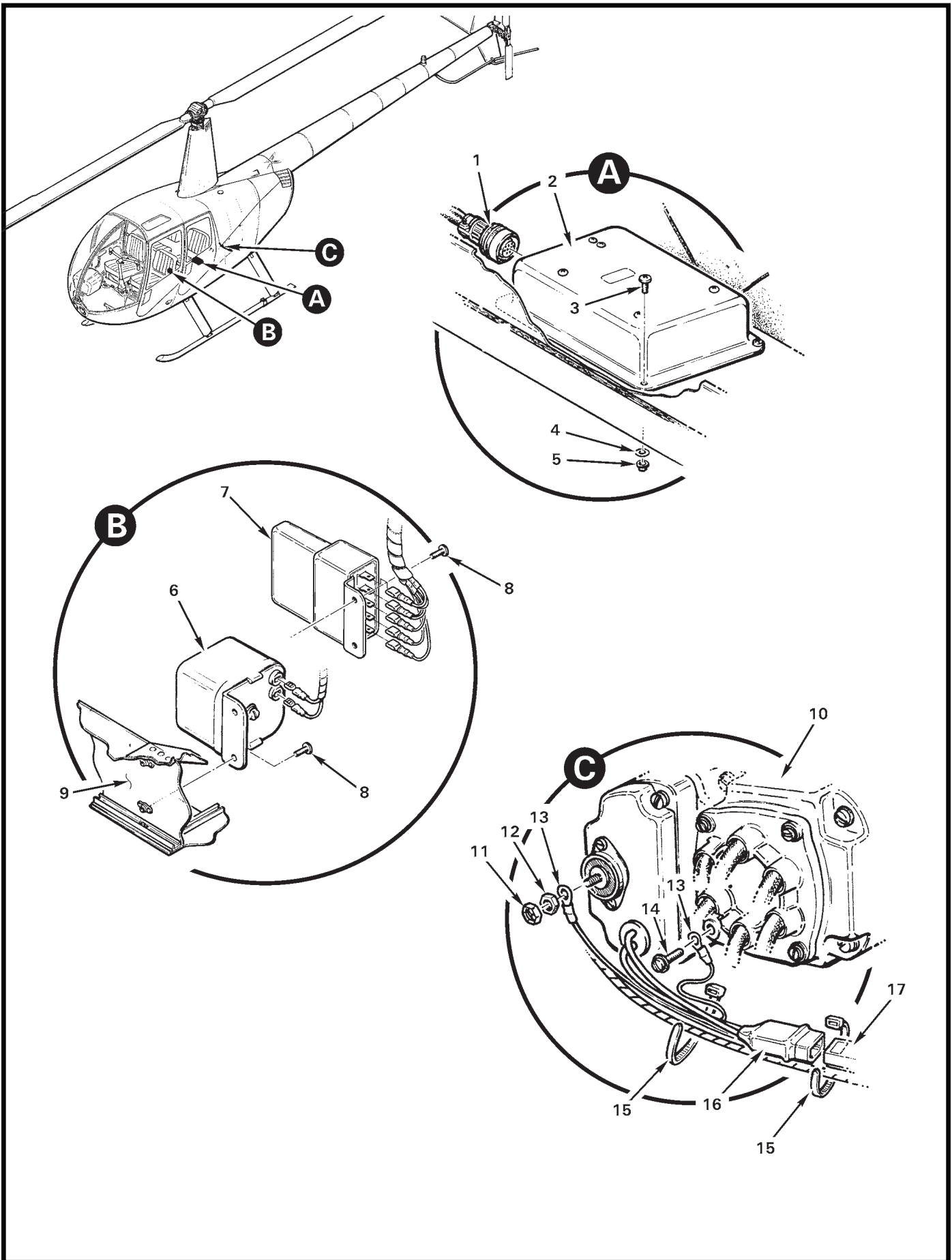

FIGURE AND INDEX NUMBER	PART NUMBER	DESCRIPTION	PARTS AVAIL	QTY PER ASSY
ELECTRICAL COMPONENTS				
96-63-1	MS3116F12-10S	Plug	X	1
2	D278-1	Controller Assembly – Governor (R44 I ship S/N 0001 thru 2624, and R44 Cadet S/N 30001 thru 30060, and 30062 thru 30070)	X	1
	D278-1R	D278-1 Controller Assembly – Governor (overhaul exchange; R7534 core deposit required)	X	1
	D278-2	Controller Assembly – Governor (R44 II ship S/N 10001 thru 14363, and 14365 thru 14411)	X	1
	D278-2R	D278-2 Controller Assembly – Governor (overhaul exchange; R9615 core deposit required)	X	1
3	MS27039C0806	Screw	X	4
4	NAS1149FN816P	Washer	X	4
5	MS21042L08	Nut	X	4
6	10-176487-121*	Starting Vibrator (14-volt ships)	X	1
	10-357487-241*	Starting Vibrator (28-volt ships)	X	1
7	SS1002**	Vibrator Start Booster (ship S/N 10001 and subsequent)	X	1
8	MS27039C1-08	Screw	X	2
9	C296	Bulkhead (Ref)		
10	10-600646-201*	Magneto – Tachometer (Ref)		
11	B330-7	Palnut ([2] required on retard mag, not shown)	X	3
12	MS35650-302	Nut ([2] required on retard mag, not shown)	X	3
13	B260-4	Terminal ([4] required on retard mag, not shown)	X	6
14	10-35937-10	Screw	X	4
15	MS3367-5-9	Ty-Rap	X	A/R
16	B263-12	Housing	X	1
	B263-1	Pin	X	2
	B158-8	Heat Shrink	X	A/R
17	B263-13	Housing	X	1
	B263-2	Socket	X	2

NOTES * Continental Motors part no.
 ** Unison part no.

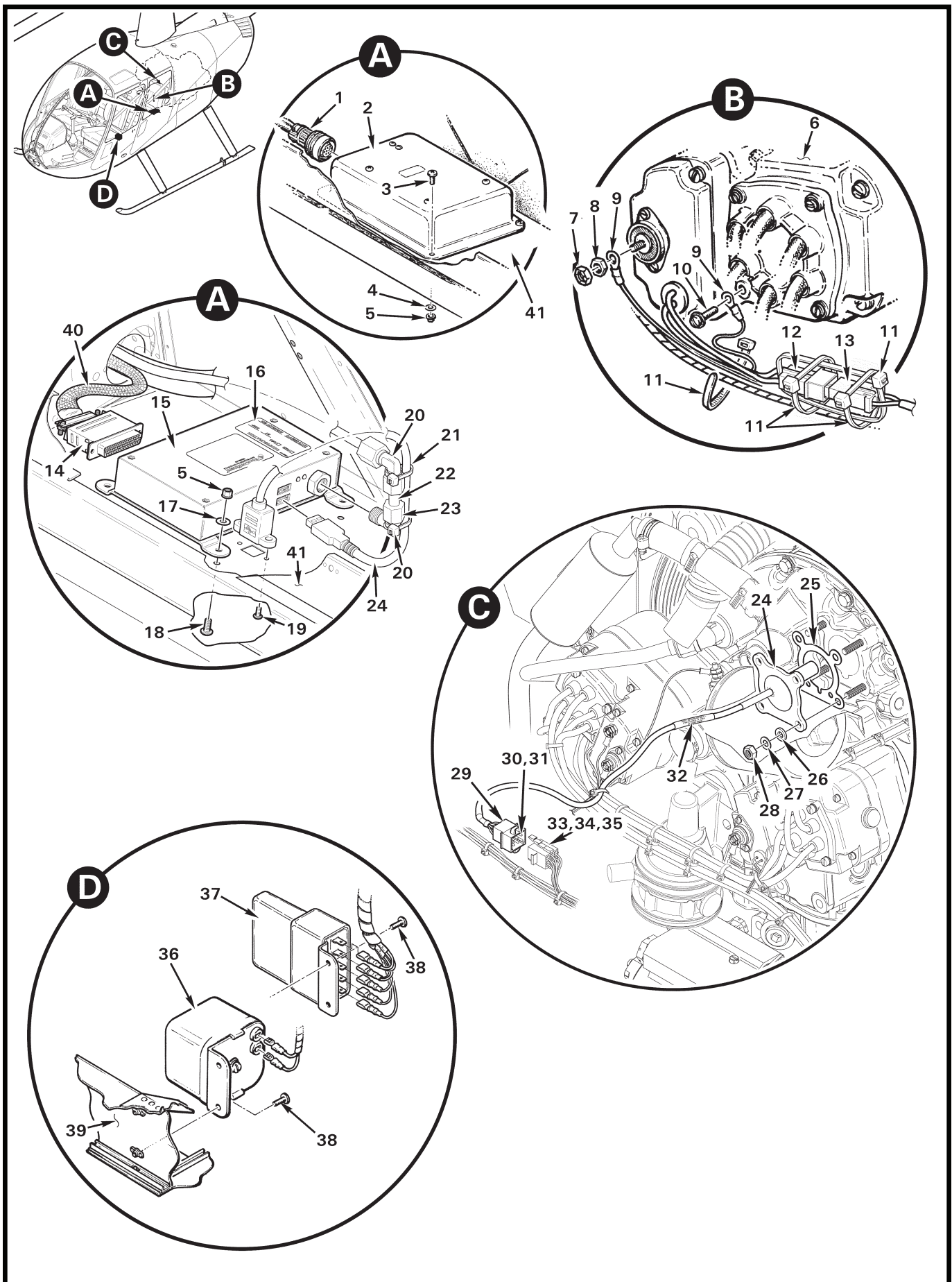

FIGURE AND INDEX NUMBER	PART NUMBER	DESCRIPTION	PARTS AVAIL	QTY PER ASSY
ELECTRICAL COMPONENTS				
96-63B-1	MS3116F12-10S	Plug	X	1
2	D278-1	Controller Assembly – Governor (Earlier R44s)	X	1
	D278-1R	D278-1 Controller Assembly – Governor (overhaul exchange)	X	1
	D278-2	Controller Assembly – Governor (Earlier R44 Raven IIs)	X	1
	D278-2R	D278-2 Controller Assembly – Governor (overhaul exchange)	X	1
3	MS27039C0806	Screw	X	4
4	NAS1149FN816P	Washer	X	4
5	MS21042L08	Nut	X	8
6	10-600646-201*	Magneto – Tachometer (Ref)		
7	B330-7	Palnut ([2] required on retard mag, not shown)	X	3
8	MS35650-302	Nut ([2] required on retard mag, not shown)	X	3
9	B260-4	Terminal (4 required on retard mag, not shown)	X	6
10	10-35937-10	Screw	X	4
11	MS3367-5-9	Ty-Rap	X	A/R
12	B263-12	Housing	X	1
	B263-1	Pin	X	2
	B158-8	Heat Shrink	X	A/R
13	B263-13	Housing	X	1
	B263-2	Socket	X	2
14	B269-82	Receptacle (Ref)		
	B269-23	Backshell (Ref)		
15	D270-1	Controller Assembly – Governor (Digital)	X	1
16	MS27039C0805	Screw	X	4
17	NAS1149FN816P	Washer	X	4
18	—	Screw	O	2
19	1598-01C	Cable	X	1
20	MS3367-4-9	Ty-Rap	X	A/R
21	40-4-2-N-O	Fitting	X	2
22	A729-69	Tube	X	1
23	50-4-N-O	Elbow	X	1
24	C143-2	Sensor Assembly (Engine tachometer; includes items 29 thru 32)	X	1

NOTES * Continental Motors part no.

FIGURE AND INDEX NUMBER	PART NUMBER	DESCRIPTION	PARTS AVAIL	QTY PER ASSY
ELECTRICAL COMPONENTS				
96-63B-25	61183	Gasket, Accessory adapter	X	1
26	STD-8*	Washer (1/4 inch plain)	X	4
27	STD-160*	Lockwasher (internal teeth)	X	4
28	STD-1411*	Nut (1/4-20, plain)	X	4
29	B263-18	Housing	X	1
30	B263-1	Pin	X	6
31	B267-3	Terminator (not shown)	X	1
32	—	Heat Shrink	X	A/R
33	B263-19	Housing (wires -2886, -2887, -2888)	X	1
34	B263-2	Socket	X	4
35	B267-2	Terminator (not shown)	X	1
36	10-176487-121**	Magneto Start Booster (14-volt ships)	X	1
	10-357487-241**	Magneto Start Booster (28-volt ships)	X	1
37	SS1002***	Magneto Start Booster (ship S/N 10001 and subsequent) . . .	X	1
38	MS27039C1-08	Screw	X	2
39	C296	Bulkhead (Ref)		
40	C859	Wire Harness (Ref)		
41	C679-3	Cover – Aft Baggage Compartment (Ref)		

NOTES * Lycoming part no.
 ** Continental Motors part no.
 *** Unison part no.

Intentionally Blank

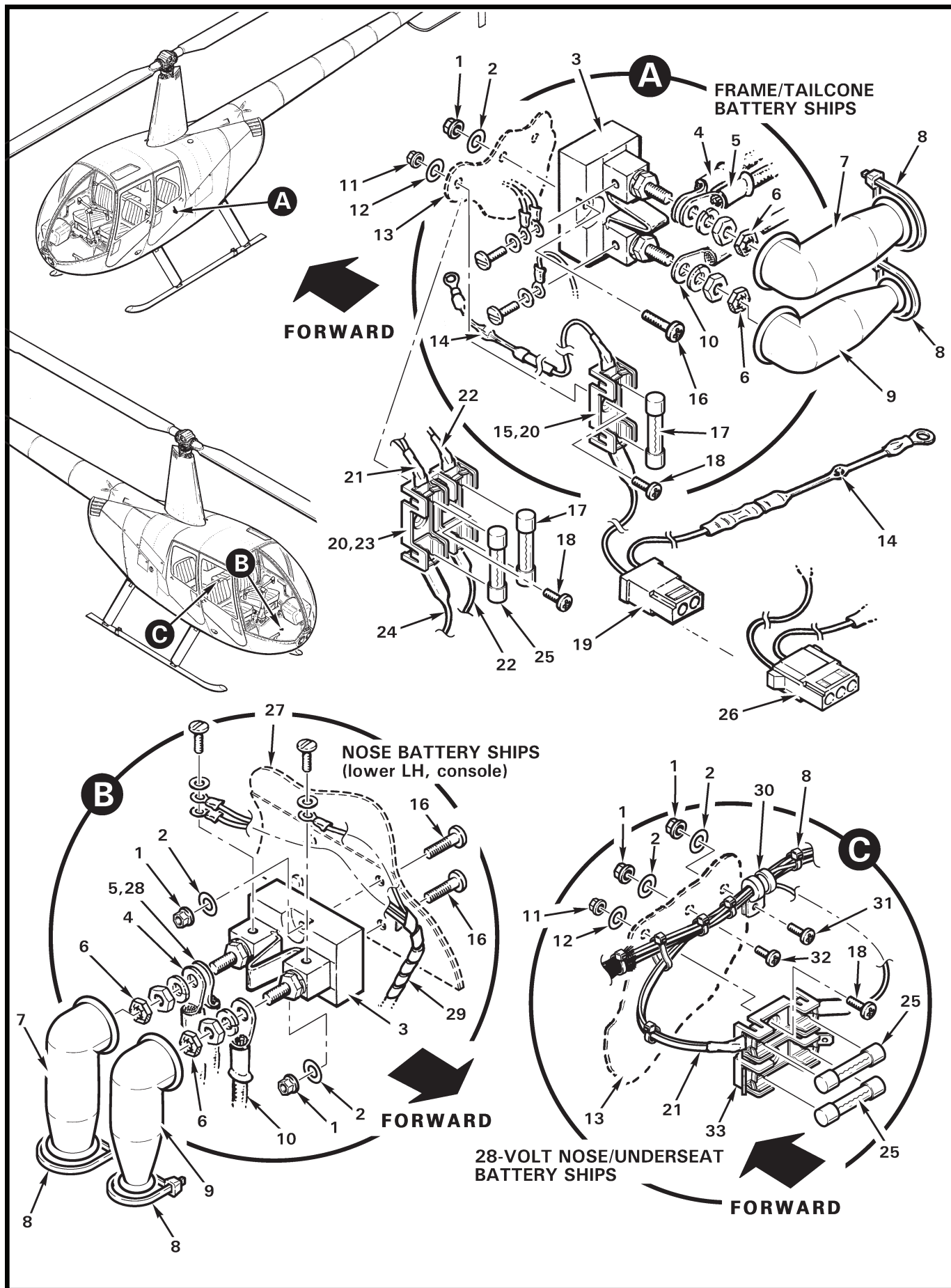

FIGURE AND INDEX NUMBER	PART NUMBER	DESCRIPTION	PARTS AVAIL	QTY PER ASSY
		ELECTRICAL COMPONENTS		
96-65-1	MS21042L08	Nut	X	2
2	NAS1149FN816P	Washer	X	2
3	1465-70-104	Shunt (includes hardware.)	X	1
4	C059-22	Wire (Ref, from alternator output)		
5	C059-14	Wire (Ref, to circuit breaker panel)		
6	B330-13	Palnut	X	2
7	MS25171-4S	Nipple	X	1
8	MS3367-4-9	Ty-Rap	X	2
9	MS25171-2S	Nipple	X	1
10	C067-580	Cable (Ref)		
11	MS21042L06	Nut	X	1
12	NAS1149FN616P	Washer	X	1
13	C233	Firewall - Vertical (Ref)		
14	A15A	Diode	X	2
15	D262-1	Fuse Block (alternate part no. 354601)	X	1
16	MS27039C0810	Screw	X	2
17	AGC-3	Fuse (3-amp)	X	1
18	MS35206-228	Screw	X	1
19	B263-13	Housing	X	1
	B263-2	Socket	X	2
20	B304-4	Diode Assembly (14-volt ships with frame battery. Includes items 11, 12, 14, 15, 17 thru 19, wires, splice, heat shrink and terminals; assembled as shown.)	X	1
	B304-5	Diode Assembly (28-volt ships with frame battery. Includes items 11, 12, 14, 17, 18, 23, 26, wires, splice, heat shrink and terminals; assembled as shown.)	X	1
21	C059-1601*	Wire (Ref)		
	C059-1602*	Wire (Ref)		
22	C059-66	Wire (Ref, to battery relay)		
23	D262-2	Fuse Block (28-volt ships, frame/tailcone battery; alternate part no. 354602)	X	1
24	C059-1528*	Wire (Ref)		
25	AGC-5*	Fuse (5-amp)	X	1

NOTES * Ship S/N 10001 and subsequent.

Continues

FIGURE AND INDEX NUMBER	PART NUMBER	DESCRIPTION	PARTS AVAIL	QTY PER ASSY
ELECTRICAL COMPONENTS (Cont'd)				
96-65-26	B263-15	Housing	X	1
	B263-2	Socket	X	2
27	C359	Panel - LH Lower Console (Ref)		
28	C059-1403	Wire (Ref)		
29	B161-2	Spirap	X	A/R
30	MS21919WDG7	Clamp	X	1
31	MS27039C0807	Screw	X	1
32	MS27039C0806	Screw	X	1
33	D262-2	Fuse Block (Ships with nose or under seat battery, S/N 10001 and higher. Alternate part no. 354602.)	X	1

NOTES

Intentionally Blank

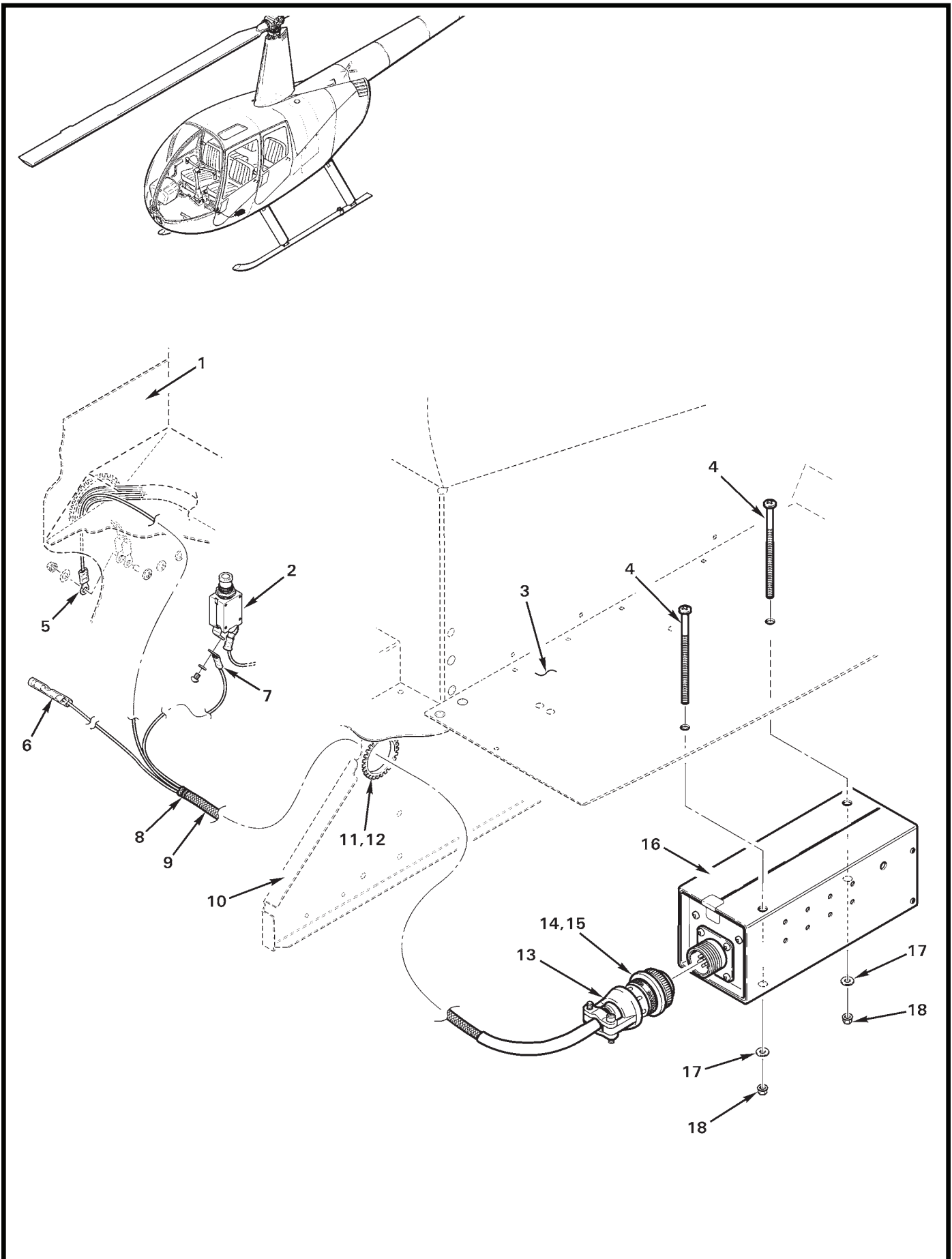

FIGURE AND INDEX NUMBER	PART NUMBER	DESCRIPTION	PARTS AVAIL	QTY PER ASSY
POWER BOOSTER INSTALLATION (14V TO 28V)*				
96-69-1	C293	Keel Panel (LH, Ref)		
2	B297-2	Circuit Breaker (2-amp)	X	1
3	C353	Panel (LH, Ref)		
4	—	Screw (supplied with item 16)	O	2
5	B260-3	Terminal ("ground" wire)	X	1
6	B261-2	Splice (28-volt "out" wire)	X	1
7	B260-2	Terminal (14-volt "in" wire)	X	1
8	B268-3	Tape - Lacing	X	A/R
9	B266-8	Sleeving	X	A/R
10	C531	Support (Ref)		
11	MS21266-1N	Grommet (install using item 12)	X	A/R
12	B270-8qt	Adhesive	X	A/R
13	M85049/2-6C	Cable Clamp	X	1
14	MS3106A14S-5S	Plug	X	1
15	D392-5	Wire Harness Assembly (Incl items 5 thru 9, 13, 14, and wiring; assembled)	X	1
16	RB125	Power Booster* (regulated; includes item 4)	X	1
17	NAS1149FN832P	Washer	X	2
18	MS21042L08	Nut	X	2

NOTES * 14-volt ships only.

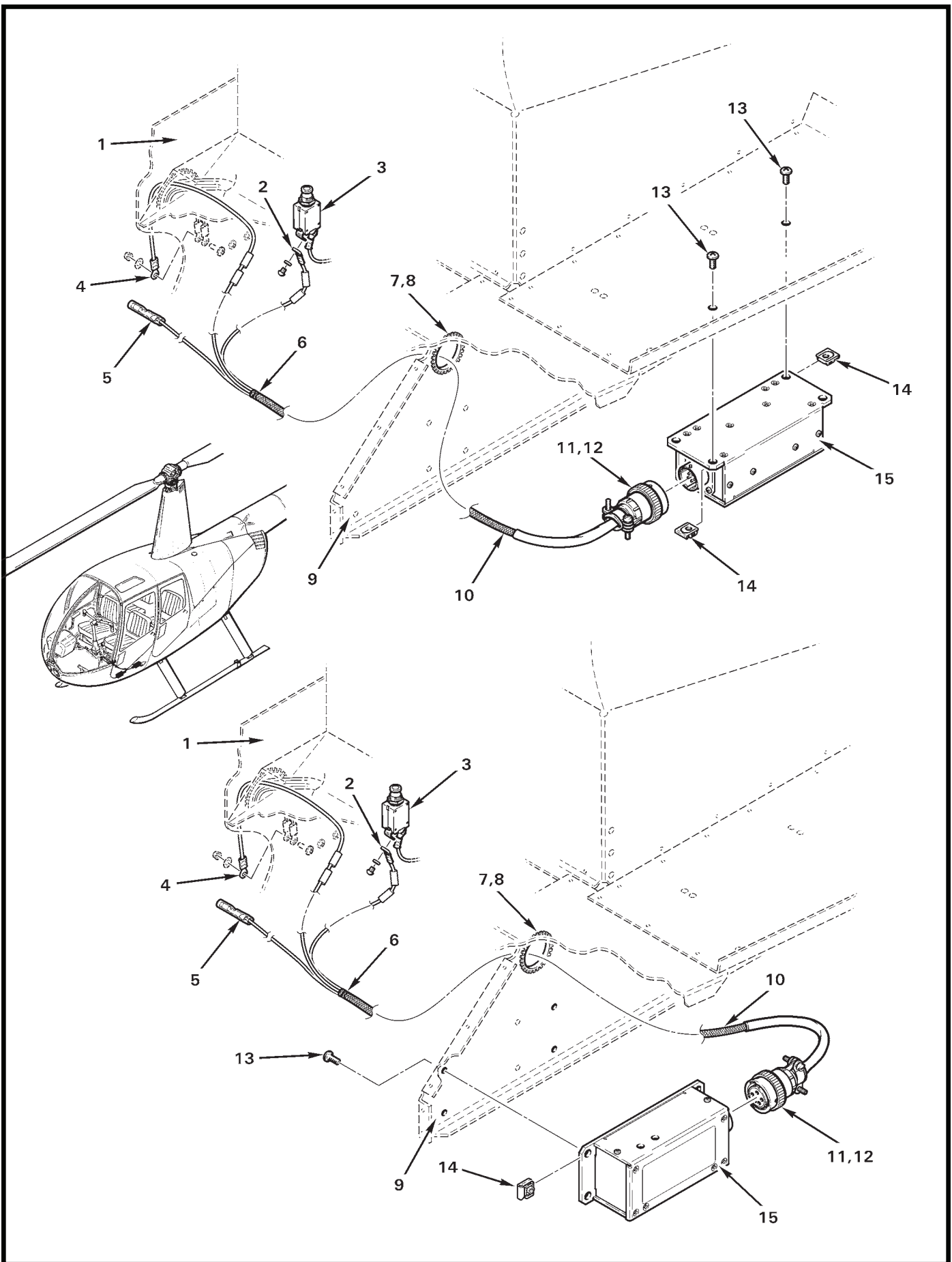

FIGURE AND INDEX NUMBER	PART NUMBER	DESCRIPTION	PARTS AVAIL	QTY PER ASSY
POWER CONVERTER INSTALLATION (28V TO 14V)				
96-71-1	C293	Keel Panel (LH, Ref)		
2	B260-2	Terminal (28-volt "in" wire)	X	1
3	B297-2	Circuit Breaker (2-amp)	X	1
4	B260-9	Terminal (ground wire)	X	1
5	B261-3	Splice (14-volt "out")	X	1
6	B268-3	Tape - Lacing	X	A/R
7	MS21266-1N	Grommet (install using item 8)	X	A/R
8	B270-8qt	Adhesive	X	A/R
9	C531	Support (Ref)		
10	B266-4	Sleeving	X	A/R
11	D392-2	Harness Assembly (Incl items 2, 4 thru 6, 10, and 12)	X	A/R
12	MS3116F14-5S	Plug	X	1
13	MS27039C0806	Screw	X	A/R
14	B162-2	Clipnut	X	A/R
15	LT-46D	Converter - Power (28- to 14-volt, 4-amp output)	X	A/R
NOTES				

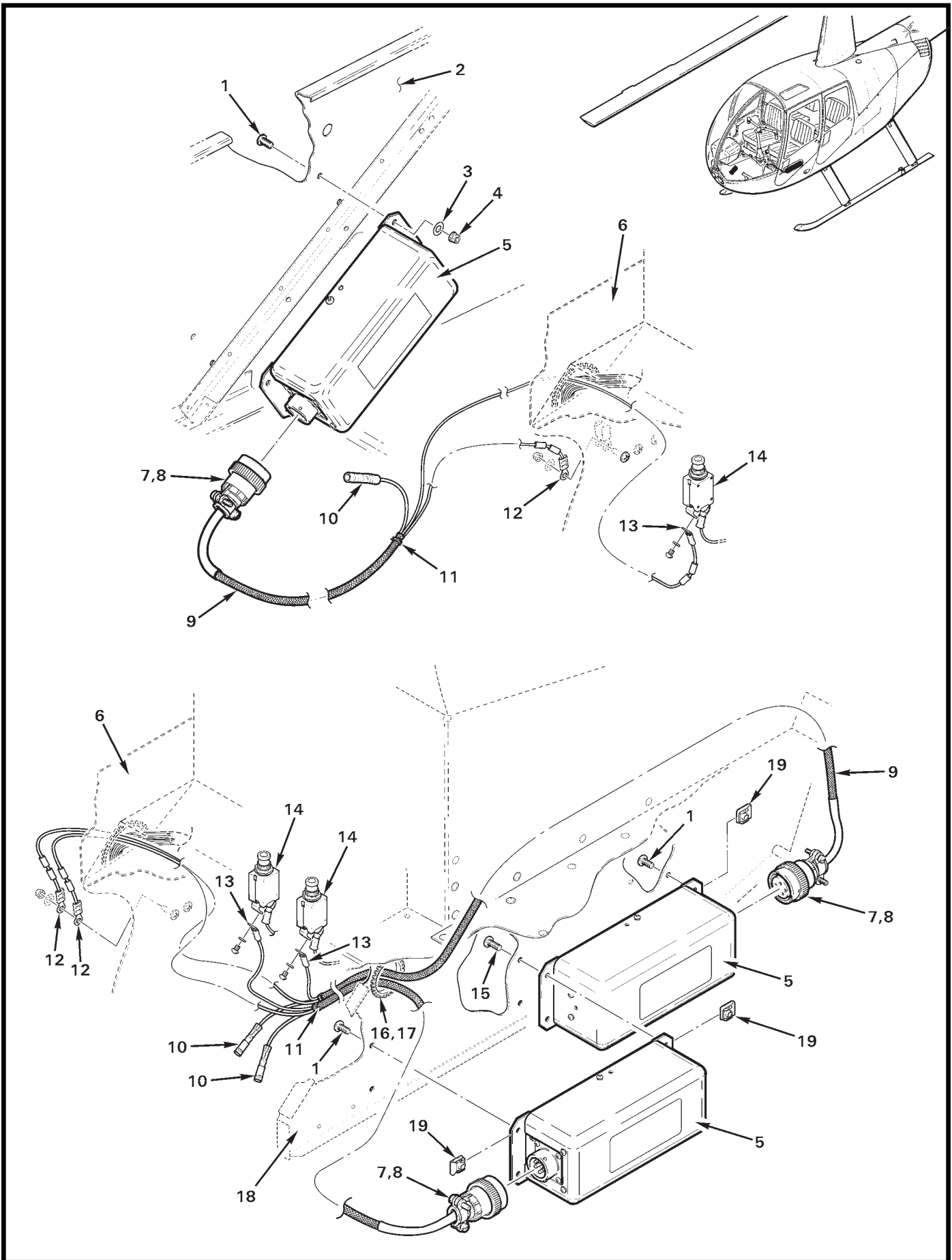

FIGURE AND INDEX NUMBER	PART NUMBER	DESCRIPTION	PARTS AVAIL	QTY PER ASSY
POWER CONVERTER INSTALLATION (28V TO 14V)				
96-73-1	MS27039C0806	Screw	X	A/R
2	C033	Lower Console Assembly (Ref)		
3	NAS1149FN832P	Washer	X	A/R
4	MS21042L08	Nut	X	A/R
5	LT-71A	Converter - Power (28- to 14-volt, 8-amp output)	X	A/R
6	C293	Keel Panel (LH, Ref)		
7	D392-2	Harness Assembly (Incl items 8 thru 13)	X	A/R
8	MS3116F14-5S	Plug	X	1
9	B266-4	Sleeving	X	A/R
10	B261-3	Splice (14-volt "out" wire)	X	1
11	B268-3	Tape - Lacing	X	A/R
12	B260-9	Terminal (ground wire)	X	1
13	B260-2	Terminal (28-volt "in" wire)	X	1
14	B297-2	Circuit Breaker (2-amp)	X	1
15	MS27039C0808	Screw	X	A/R
16	MS21266-1N	Grommet (install using item 17)	X	A/R
17	B270-8qt	Adhesive	X	A/R
18	C531	Support (Ref)		
19	B162-2	Clipnut	X	A/R

NOTES

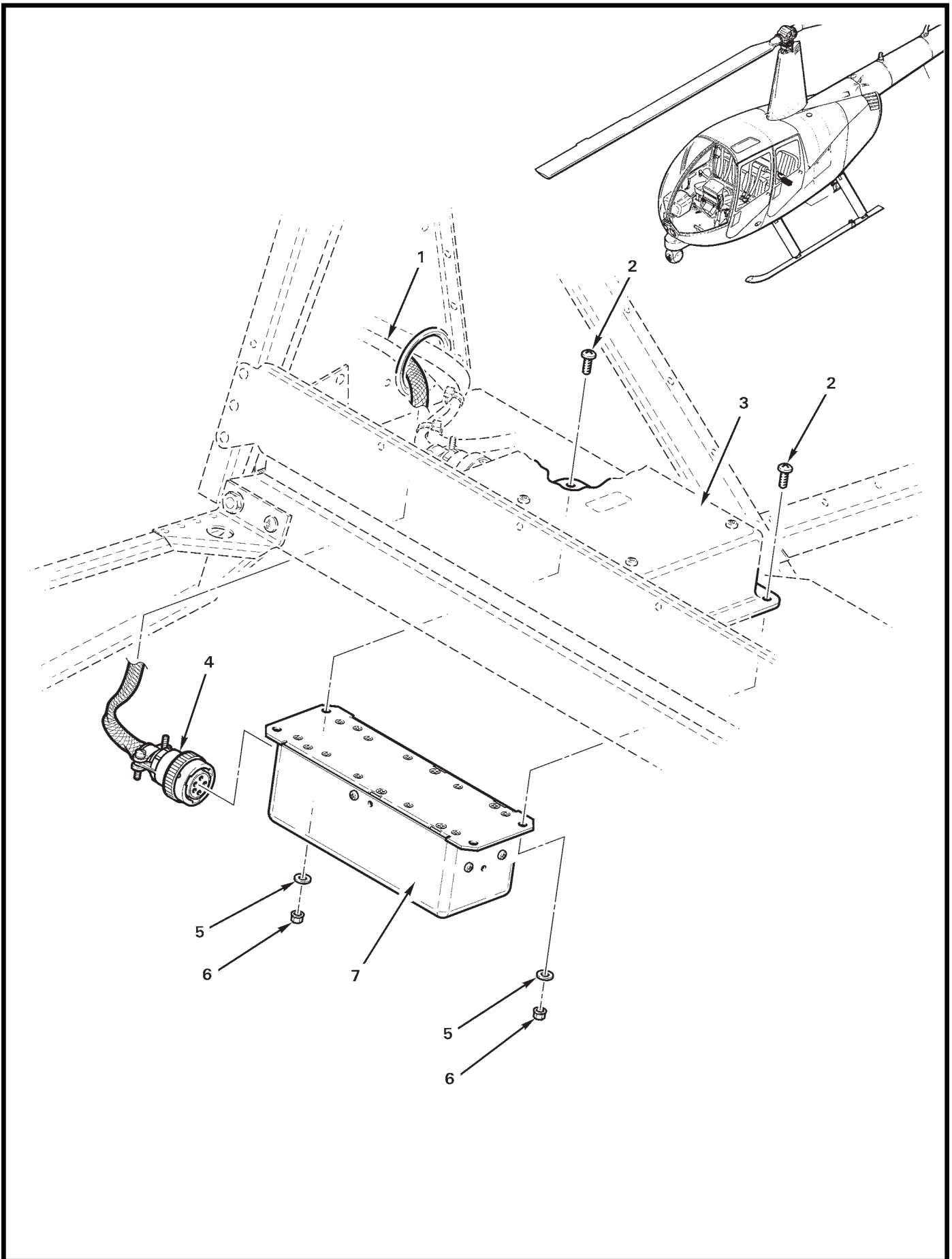

FIGURE AND INDEX NUMBER	PART NUMBER	DESCRIPTION	PARTS AVAIL	QTY PER ASSY	
96-75-1	D058-1	POWER CONVERTER INSTALLATION (28V TO 14V)			
		Harness Assembly (Ref, Police Ship only; contact Customer Service for replacement)			
	2	MS27039C0807	Screw	X	1
	3	D278	Controller Assembly - Governor (Ref)		
	4	MS3116F14-5S	Plug	X	1
	5	NAS1149FN816P	Washer	X	1
	6	MS21042L08	Nut	X	1
	7	LT-71A	Converter - Power (28- to 14-volt, 8-amp output)	X	1

NOTES

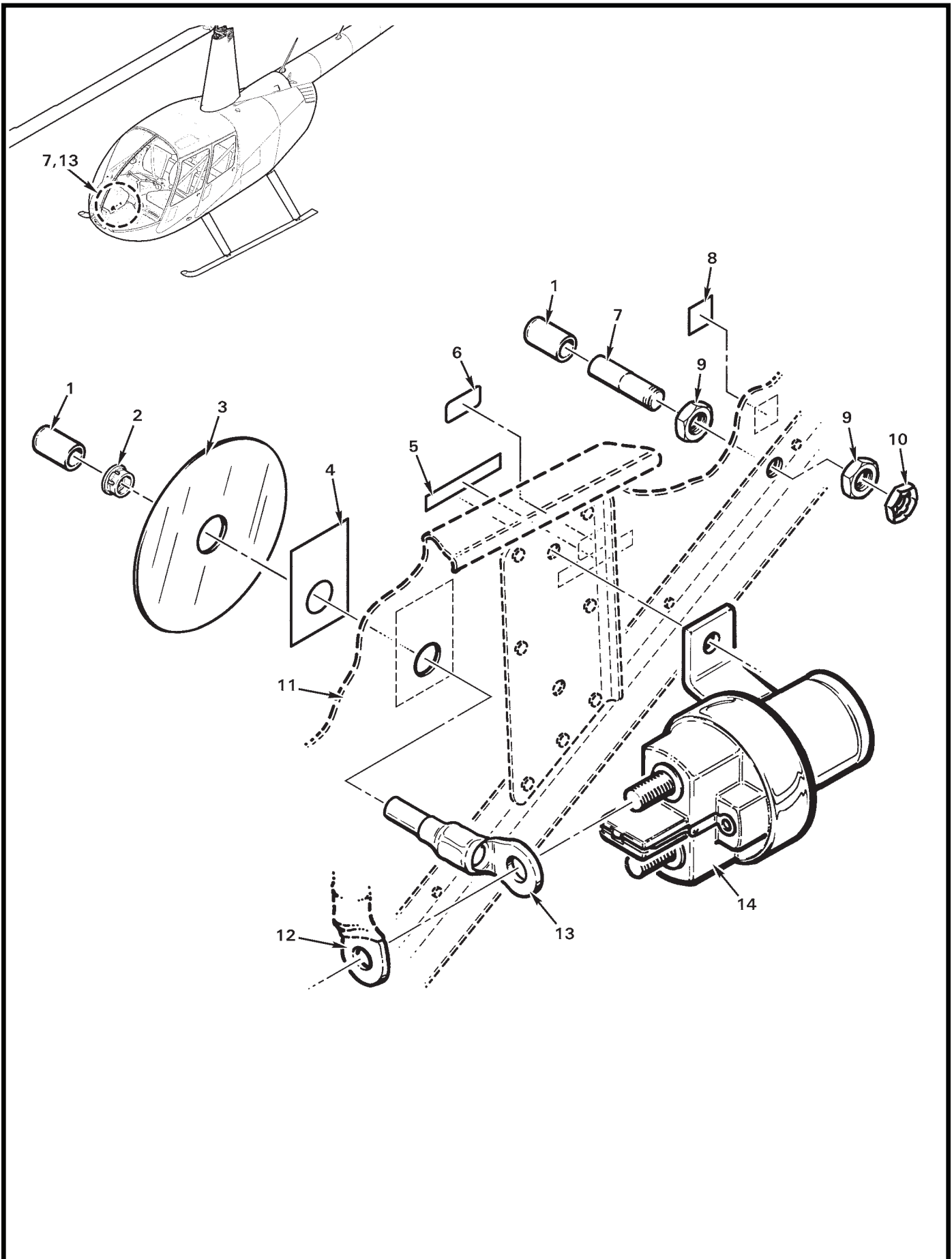

FIGURE AND INDEX NUMBER	PART NUMBER	DESCRIPTION	PARTS AVAIL	QTY PER ASSY
BATTERY CHARGING POST INSTALLATION				
96-77-1	A959-10	Cap	X	2
2	2813	Bushing	X	1
3	D548-4	Insulator	X	1
4	D682-22	Decal - " + "	X	1
5	D682-21	Decal - "For Charging Only"	X	1
6	C654-22	Decal - "28V"	X	1
	C654-29	Decal - "14V"	X	1
7	D548-3	Stud	X	1
8	D682-23	Decal - " - "	X	1
9	AN316-4R	Nut	X	2
10	B330-13	Palnut	X	1
11	C359-2	Console Panel (Ref)		
12	A780-35	Cable Assembly (Ref)		
13	D548-1	Stud Assembly	X	1
14	B415	Relay (Ref)		
15	KI-177	Battery Charging Studs Installation Kit (Incl items 1 thru 10, and 13)	X	1

NOTES

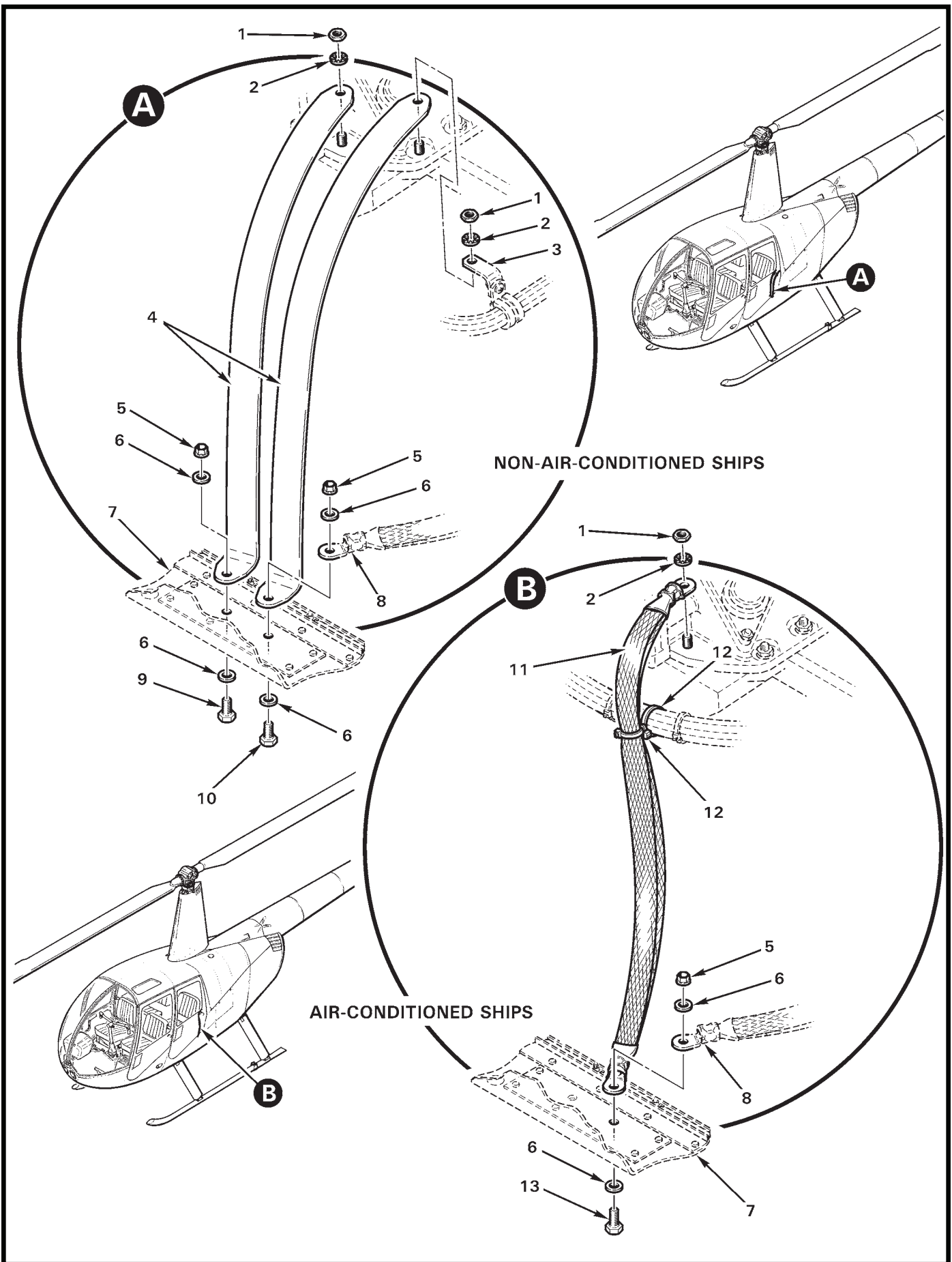

FIGURE AND INDEX NUMBER	PART NUMBER	DESCRIPTION	PARTS AVAIL	QTY PER ASSY
ENGINE GROUND STRAPS INSTALLATION				
96-79-1	STD-1411*	Nut	X	2
2	STD-160*	Lockwasher	X	2
3	C357-1	Clip (Ref)		
4	A212-2	Strap	X	2
5	MS21042L4	Nut	X	2
6	NAS1149F0432P	Washer	X	4
7	C015-3	Skin (LH cabin belly; Ref)		
8	A780-22	Cable Assembly (Ref)		
9	AN4-3A	Bolt	X	2
10	AN4-3A	Bolt	X	1
	AN4-4A	Bolt	X	1
11	A780-45	Cable Assembly	X	1
12	MS3367-5-9	Ty-Rap	X	2
13	AN4-4A	Bolt	X	1

NOTES * Lycoming part no.

Intentionally Blank

CHAPTER 97

AVIONICS

<i>Figure</i>	<i>Title</i>	<i>Page</i>
97-1	Garmin G500 EFIS – GTN 6XX/7XX-series GPS	97.0
97-5	Garmin G500 EFIS – GSU 75H ADAHRS	97.4
97-9	Garmin G500 EFIS – GMU 44 Magnetometer	97.8
97-11	Avionics Console	97.10
97-13	Pilot’s Side Avionics Console	97.12
97-17	Pilot’s Side Avionics Console	97.16
97-21	Headset Jacks	97.20
97-23	Intercom Control Installation	97.22
97-25	ICS Cyclic Grip Switches Installation	97.24
97-27	ICS Floor Switch Installation	97.26
97-29	Transponder and Blind Encoder	97.28
97-33	Blind Encoder Installation	97.32
97-35	Avionics Blower Installation	97.34
97-37	Avionics Blower Installation	97.36
97-39	Avionics Blower Installation	97.38
97-41	C802-2 COM Radio Installation	97.40
97-43	C803-1 ADS-B Installation	97.42
97-45	Garmin GTX 325, 335 and 345 Transponder & Blind Encoder	97.44
97-47	C804-15 Transponder Installation	97.46
97-49	C807-1 King KTR 909 UHF Transceiver Installation	97.48
97-53	C831 GPS Installation – Garmin GTN 600 Series	97.52
97-57	C831 GPS Installation – Garmin GTN 600 Series (Dual)	97.56
97-61	C831 GPS Installation – Garmin GTN 700 Series	97.60

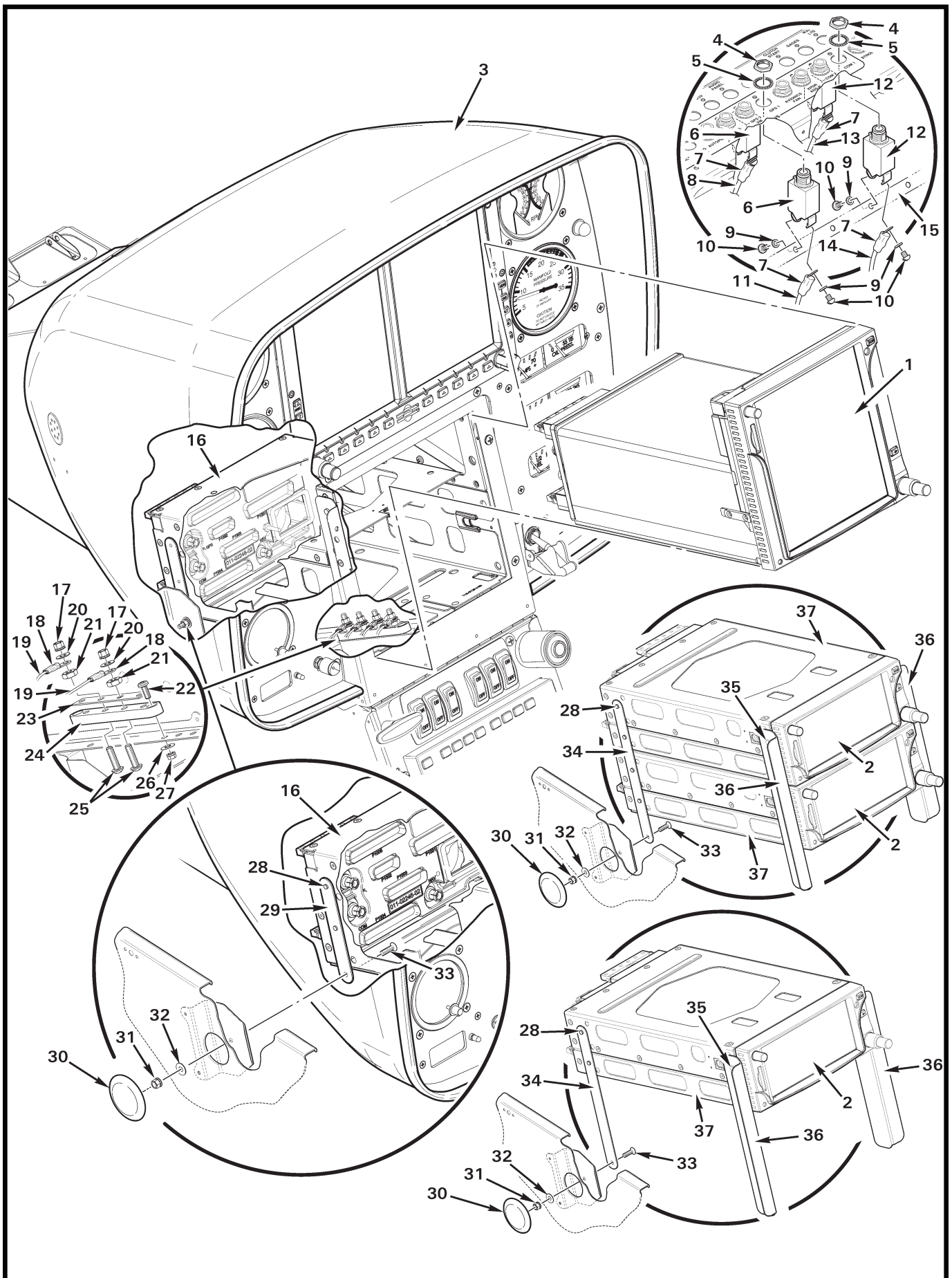

FIGURE AND INDEX NUMBER	PART NUMBER	DESCRIPTION	PARTS AVAIL	QTY PER ASSY
		GARMIN G500H EFIS – GTN 6XX/7XX-SERIES GPS		
97-1-1	GTN 750*	Transceiver	X	1
	GTN 725*	Transceiver	X	1
2	GTN 650*	Transceiver	X	1
	GTN 635*	Transceiver	X	1
	GTN 625*	Transceiver	X	1
3	G060	Console Assembly (Ref)		
4	—	Nut	O	1
5	—	Lockwasher	O	1
6	B297-5	Circuit Breaker (5 amp, “GPS/XM” and “GPS 2”; includes items 4, 5, 9, and 10)	X	A/R
7	B260-2	Terminal	X	A/R
8	-1426	Wire (Ref)		
9	—	Washer	O	1
10	—	Screw	O	1
11	-466	Wire (Ref)		
12	B297-5	Circuit Breaker (5 amp, “COM 1” and “COM 2”; includes items 4, 5, 9, and 10)	X	A/R
13	-704	Wire (Ref)		
14	-200	Wire (Ref)		
15	A448	Bus Bar (Ref)		
16	115-01294-00*	Mounting Rack (Ref)		
17	MS21042L08	Nut	X	A/R
18	B260-3	Terminal	X	A/R
19	-465	Wire (Ref)		
	-1427	Wire (Ref)		
	-2506	Wire (Ref)		
	-2537	Wire (Ref)		
	-201	Wire (Ref)		
	-704	Wire (Ref)		
	-2531	Wire (Ref)		
20	NAS1149FN816P	Washer	X	A/R
21	B301-8	Nut	X	4
22	MS35206-228	Screw	X	2
23	A448-10	Bus Bar	X	1
24	C448-2	Terminal Block Assembly (Incl items 21, 23, and 25)	X	1
	C448-5	Block (Ref)		

NOTES * Garmin part number.

Continues

FIGURE AND INDEX NUMBER	PART NUMBER	DESCRIPTION	PARTS AVAIL	QTY PER ASSY
GARMIN G500H EFIS – GTN 6XX/7XX-SERIES GPS (Cont'd)				
97-1-25	B567-43	Screw (install using B270-9 adhesive under head)	X	4
26	NAS1149FN616P	Washer	X	2
27	MS21042L06	Nut	X	2
28	NAS1097AD3	Rivet	X	A/R
29	A684-4	Strap	X	2
30	SI413	Hole Plug	X	2
31	MS21042L06	Nut	X	2
32	NAS1149FN616P	Washer	X	2
33	—	Screw (6-32 CSK supplied with radio)	O	2
34	A684-3	Strap	X	2
35	MS20426AD4	Rivet	X	6
36	C905-6	Angle	X	2
37	115-01293-00*	Mounting Rack (Ref)		

NOTES * Garmin part number.

Intentionally Blank

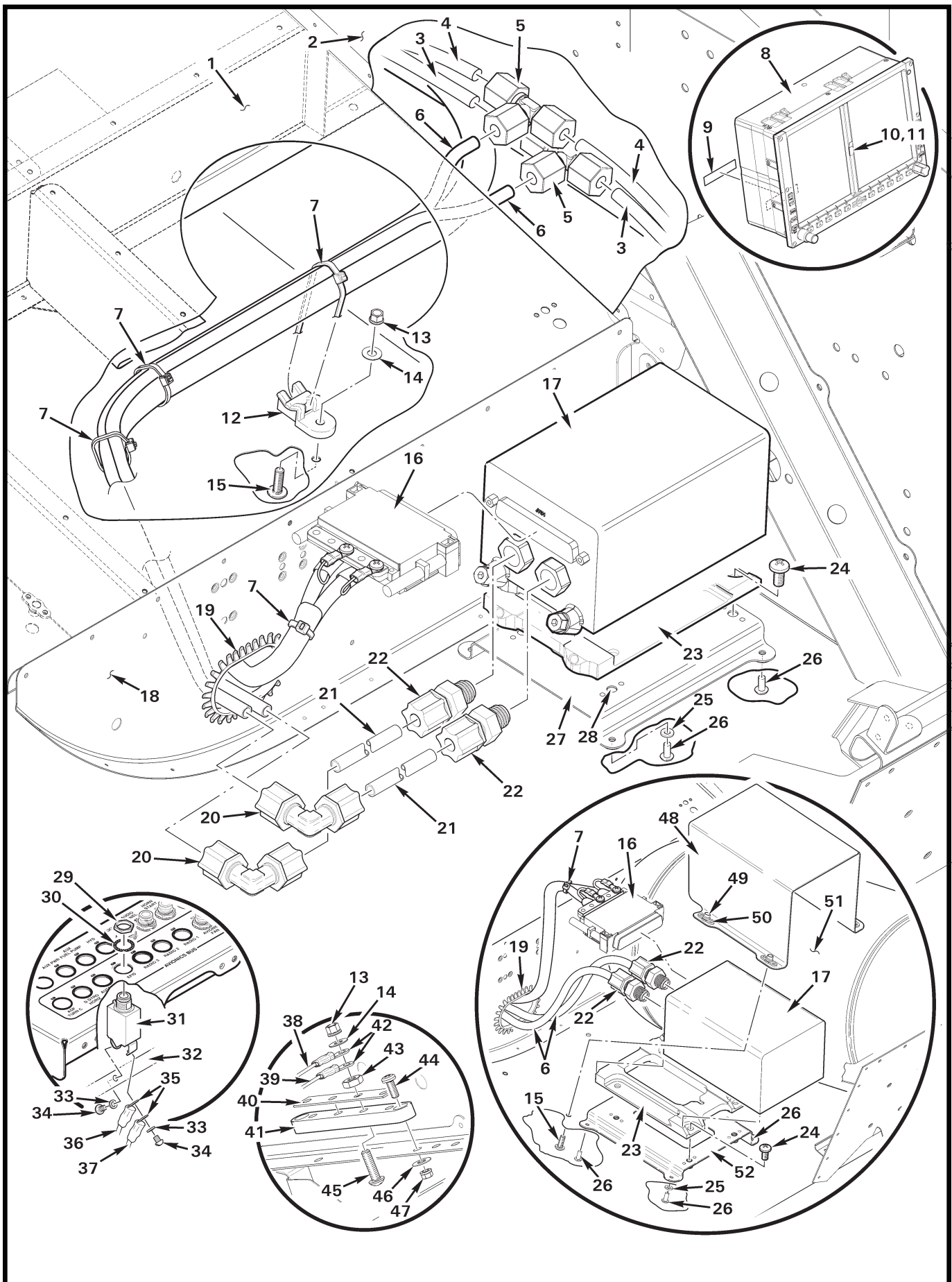

FIGURE AND INDEX NUMBER	PART NUMBER	DESCRIPTION	PARTS AVAIL	QTY PER ASSY
GARMIN G500H EFIS – GSU 75H ADAHRS				
97-5-1	C232-3	Floor Panel (LH, Ref)		
2	C293-3	Keel Panel (LH, Ref)		
3	A729-6	Tube (pitot, Ref)		
4	A729-11	Tube (static, Ref)		
5	70-4-N-0	Tee	X	2
6	A729-22	Tube	X	2
7	MS3367-4-9	Ty-Rap	X	A/R
8	GDU 620*	Display (Ref)		
9	C654-60	Decal – “ROBINSON P/N F817-2...”	X	1
10	D327-2	Retainer (Incl item 11)	X	1
11	A701-7	Tape (black foam, adhesive both sides)	X	A/R
12	D268-1	Support	X	1
13	MS21042L08	Nut	X	2
14	NAS1149FN816P	Washer	X	2
15	B526-8	Screw	X	5
16	O11-3109-00*	Connector Kit (Ref)		
17	GSU 75H*	ADAHRS Unit (Garmin part no. 011-03094-00; Ref)		
18	D230-2	Bulkhead (Ref)		
19	A225-2	Grommet	X	A/R
20	50-4-N-0	Elbow	X	2
21	A729-26	Tube	X	2
22	10-4-2-N-0	Fitting	X	2
23	117-00608-00*	Rack (Ref)		
24	MS27039C1-06	Screw	X	4
25	NAS620-5	Washer	X	A/R
26	MS20470AD4	Rivet	X	4
27	F950-9	Support Assembly (Incl item 28)	X	1
28	MS21069L3	Nutplate (install using item 50)	X	4
29	—	Nut	O	1
30	—	Washer	O	1
31	B297-5	Circuit Breaker (5 amp; includes items 29, 30, 33, and 34) . .	O	1
32	A448	Bus Bar (Ref)		
33	—	Washer	O	1
34	—	Screw	O	1
35	B260-2	Terminal	X	2
36	-2695	Wire (power, GSU 75 ADAHRS, Ref)		

NOTES * Garmin part no.

Continues

FIGURE AND INDEX NUMBER	PART NUMBER	DESCRIPTION	PARTS AVAIL	QTY PER ASSY
GARMIN G500H EFIS – GSU 75H ADAHRS (Cont'd)				
97-5-37	-2563	Wire (power, GDU 620 Display, Ref)		
38	-2589	Wire (ground, GSU ADAHRS, Ref)		
39	-2564	Wire (ground, GDU 620 Display, Ref)		
40	A448-10	Bus Bar (4-holes)	X	1
41	C448-5	Block (4-holes)	X	1
42	B260-3	Terminal	X	2
43	B301-8	Nut	X	2
44	MS35206-228	Screw	X	2
45	B567-43	Screw	X	1
46	NAS1149FN616P	Washer	X	2
47	MS21042L06	Nut	X	2
48	F950-13*	Cover Assembly (Incl items 49 and 50)	X	1
49	MS21069L08	Nutplate	X	4
50	NAS1097AD3	Rivet	X	16
51	D679	Cylinder Assembly (Ref, pop-out floats installation)		
52	F950-11*	Support Assembly (Incl items 28 and 50)	X	1

NOTES * Garmin part no.

Intentionally Blank

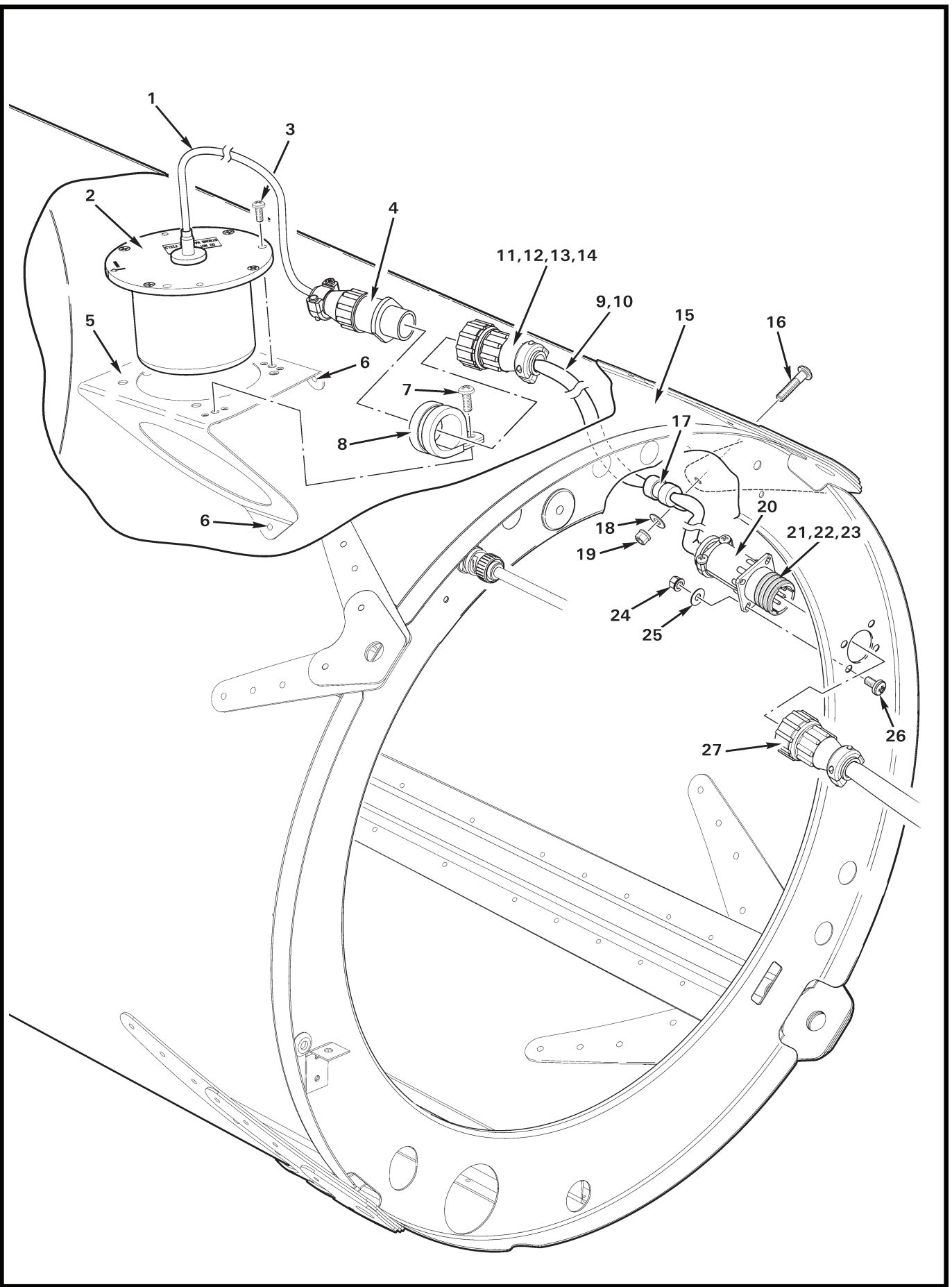

FIGURE AND INDEX NUMBER	PART NUMBER	DESCRIPTION	PARTS AVAIL	QTY PER ASSY
		GARMIN G500H EFIS – GMU 44 MAGNETOMETER		
97-9-1	—	Cable (Ref)	O	1
2	GMU 44*	Magnetometer (Incl items 1 and 4)	X	1
3	MS27039C0807	Screw	X	3
4	—	Connector (Ref)		
5	F950-4	Bracket Assembly (includes nutplates)	X	1
6	MS20470AD4	Rivet	X	3
7	MS27039C0806	Screw	X	1
8	MS21919WDG12	Clamp	X	1
9	F951-1	Harness Assembly (With item 2 installed in the first bay. Includes items 10 thru 14, 20 thru 23, and wires, assembled)	X	1
10	F951-2	Harness Assembly (With item 2 installed in the second bay. Includes items 10 thru 14, 20 thru 23, and wires, assembled)	X	1
11	206485-1	Plug	X	1
	206358-5	Backshell	X	1
12	205090-1	Socket (not shown)	X	7
13	B267-3	Terminator (not shown)	X	2
14	B158-6	Heat Shrink (not shown).	X	A/R
15	C023	Tailcone Assembly (Ref)		
16	MS27039C0808	Screw	X	1
17	MS21919WDG3	Clamp	X	1
18	NAS1149FN816P	Washer	X	1
19	MS21042L08	Nut	X	1
20	206486-1	Receptacle	X	1
	206358-5	Backshell	X	1
21	205089-1	Pin (not shown)	X	7
22	B267-3	Terminator (not shown)	X	2
23	B158-6	Heat Shrink (not shown)	X	A/R
24	MS21042L04	Nut	X	4
25	NAS1149FN416P	Washer	X	4
26	MS23506-215	Screw	X	4
27	206485-1	Plug (Ref, backshell/socket)		

NOTES * Garmin part no.

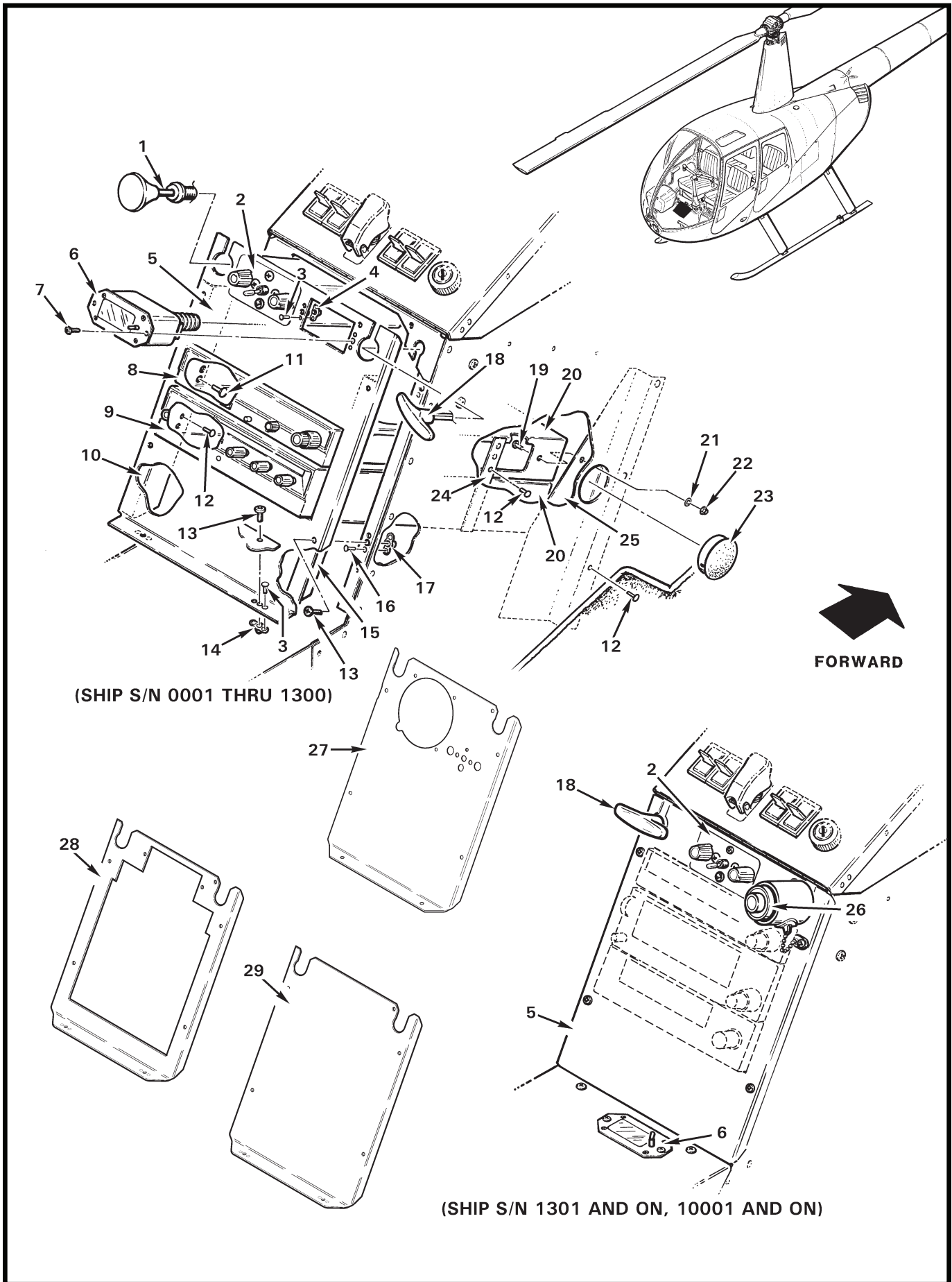

FIGURE AND INDEX NUMBER	PART NUMBER	DESCRIPTION	PARTS AVAIL	QTY PER ASSY
		AVIONICS CONSOLE		
97-11-1	A522-8	Control – Cabin Heat (Ref, see Figure 21-1)		
2	B338-1	Intercom System Unit (Ref, see Figure 97-23)		
3	MS20426AD3	Rivet	X	4
4	NAS697A04	Nutplate	X	2
5	C641	Face – Avionics (C641-4 face shown. Please specify dash no. when ordering. Includes items 3, 4, and 14.)	X	1
6	B341-1	Outside Air Temperature Gage (Includes item 7. See also Figure 96-49.)	X	1
7	—	Screw	O	2
8	KY 197A	VHF Comm Transceiver (Bendix/King, TSO'd. Includes items 19 and 20.)	O	1
9	KT 76A	Transponder (Optional, Bendix/King, TSO'd. Includes item 20.)	O	1
10	C905-3	Angle (supersedes C905-1 [LH] angle)	X	1
11	MS20426AD5	Rivet	X	1
12	MS20426AD3	Rivet	X	A/R
13	MS27039C0806	Screw	X	7
14	MS21069L08	Nutplate	X	2
15	C905-3	Angle (supersedes C905-2 [RH] angle)	X	1
16	NAS1097AD3	Rivet	X	10
17	MS21075L08E	Nutplate	X	5
18	C522-5	Control – Cabin Air Vent (Ref, see Figure 21-1)		
19	—	Screw	O	2
20	—	Tray (Ref, supplied with radio)		
21	NAS1149FN616P	Washer	X	2
22	MS21042L06	Nut	X	2
23	SI413**	Hole Plug (1.0-in. diameter)	X	2
24	A684-1	Strap	X	2
25	A371-3	Stiffener (supersedes A371-1 [LH] and A371-2 [RH] stiffeners)	X	2
26	A522-13*	Control – Fuel Mixture (Ref; shown with guard installed. See also Figure 76-17.)		
27	C641-2	Face – Avionics (blank with indicator hole)	X	1
	C641-1	Face – Avionics (blank <u>without</u> indicator hole; not shown) . .	X	1
28	D225	Face – Avionics (For use when audio control unit is installed. D225-18 Face shown. Please specify dash no. when ordering)	X	1
29	D225-101	Face – Avionics (blank)	X	1

NOTES * Ship S/N 10001 thru 29999.

** Earlier R44s with 1.25-in hole use DP-1250.

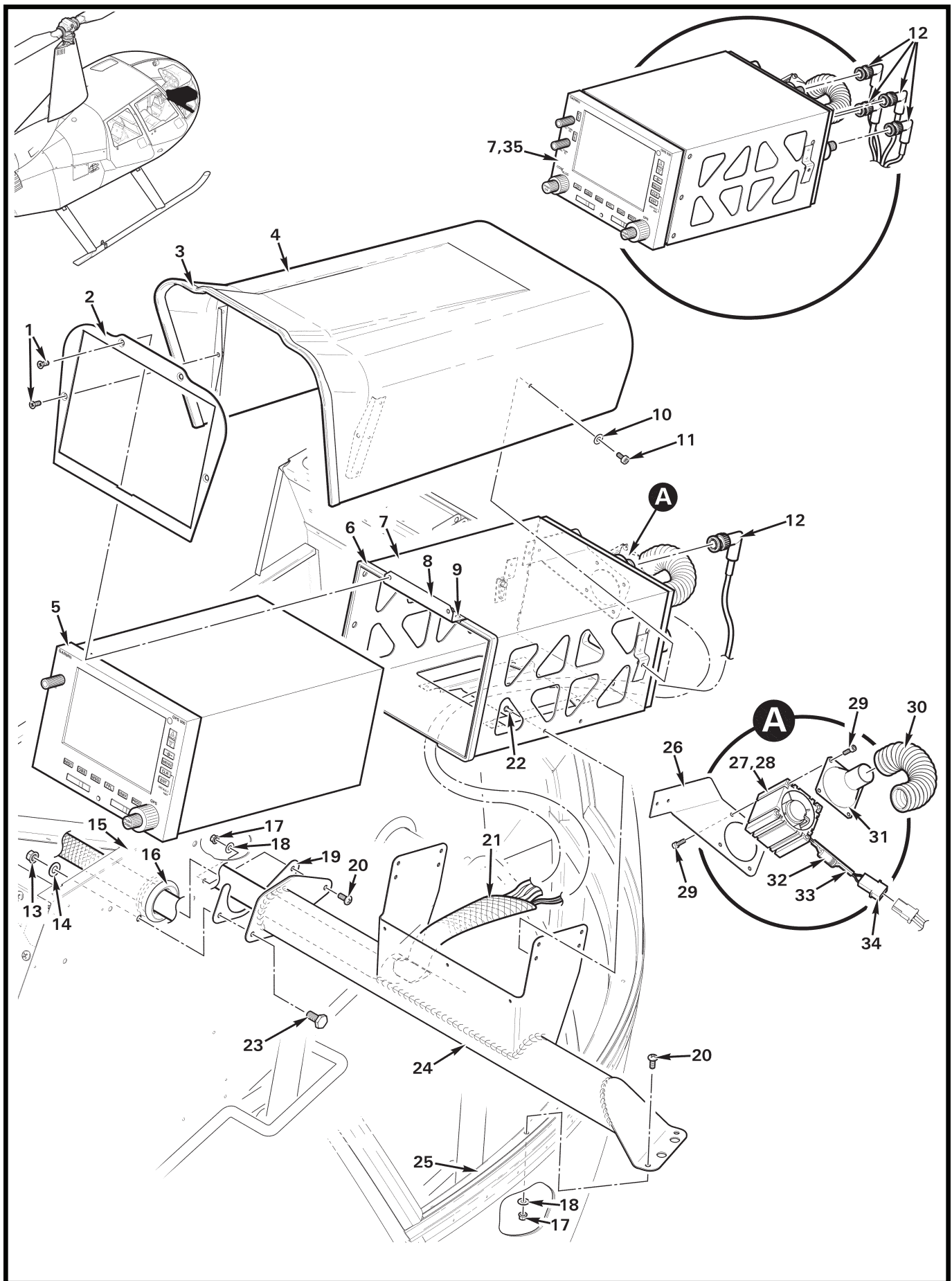

FIGURE AND INDEX NUMBER	PART NUMBER	DESCRIPTION	PARTS AVAIL	QTY PER ASSY
PILOT'S SIDE AVIONICS CONSOLE				
97-13-1	MS24693-S26	Screw	X	4
2	D704-1	Faceplate	X	1
3	A226-11	Trim	X	A/R
4	D184-1	Shell Assembly (Incl item 3)	X	1
5	GPS 500W	GPS Receiver (Garmin)	X	1
6	A226-7	Seal	X	A/R
7	—	Radio Rack Assembly (supplied with receiver or transceiver) . .	O	1
8	D704-9	Angle Assembly	X	1
9	MS20426AD3	Rivet (Ref)		
10	NAS1149FN616P	Washer	X	2
11	92196A145	Screw	X	2
12	5225973-4	Plug (90° BNC, one plug for GPS wiring, additional plugs for Com and Nav wiring; lead free)	X	A/R
13	MS21042L4	Nut	X	1
14	NAS1149F0432P	Washer	X	1
15	C359-2	Panel – Console (Ref)		
16	NAS557-14B	Grommet	X	1
17	MS21042L08	Nut	X	3
18	NAS1149FN816P	Washer	X	3
19	D703-11	Shim	X	A/R
	D706-8	Shim (earlier aircraft)	X	A/R
20	MS27039C0806	Screw	X	3
21	B266-8	Sleeve	X	A/R
22	NAS1097AD4	Rivet (Ref)		
23	NAS6604-2	Bolt	X	1
24	D703-10	Support Weldment	X	1
	D703-1	Support Weldment (Ref, earlier aircraft)		
25	C238-18	Windshield Frame – RH Chin (Ref)		
26	D704-6	Bracket	X	1
27	D580-2	Fan Assembly (Incl items 28, 32 thru 34, and wires; 28-volt ships)	X	1
	D580-3	Fan Assembly (Incl items 28, 33, 34, and wires; 14-volt ships)	X	1
28	D351M-024GK-2	Fan	X	1
29	92196A108	Screw	X	8
30	5399K17	Hose	X	1

NOTES

Continues

FIGURE AND INDEX NUMBER	PART NUMBER	DESCRIPTION	PARTS AVAIL	QTY PER ASSY
PILOT'S SIDE AVIONICS CONSOLE (Cont'd)				
97-13-31	D704-11	Nozzle	X	1
32	SPH-330	Resistor (28-volt ships only)	X	1
33	B158-404	Heat Shrink (28-volt ships)	X	A/R
	B158-2	Heat Shrink (14-volt ships)	X	A/R
34	B263-12	Housing	X	1
	B263-1	Pin	X	2
35	GNS 530AW	GPS Transceiver (Garmin, Ref)	X	1
NOTES				

Intentionally Blank

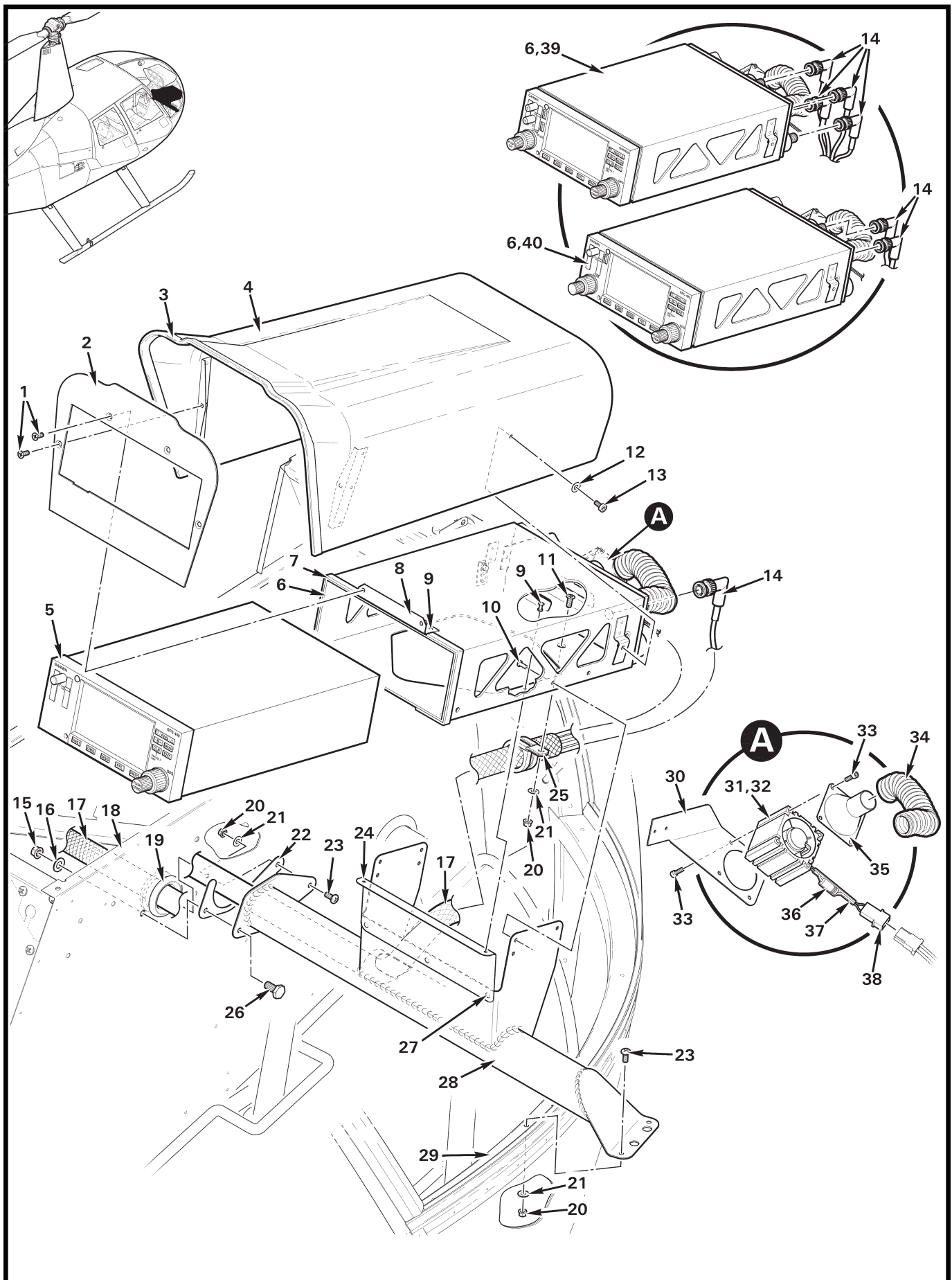

FIGURE AND INDEX NUMBER	PART NUMBER	DESCRIPTION	PARTS AVAIL	QTY PER ASSY
		PILOT'S SIDE AVIONICS CONSOLE		
97-17-1	MS24693-S26	Screw	X	4
2	D704-2	Faceplate	X	1
3	A226-11	Trim	X	A/R
4	D184-1	Shell Assembly (Incl item 3)	X	1
5	GPS 400W	GPS Receiver (Garmin)	X	1
6	—	Radio Rack Assembly (supplied with receiver or transceiver) . .	O	1
7	A226-7	Seal	X	A/R
8	D704-9	Angle Assembly	X	1
9	MS20426AD-3	Rivet (Ref)		
10	NAS1097AD-4	Rivet (Ref)		
11	MS24694-S4	Screw	X	1
12	NAS1149FN616P	Washer	X	2
13	92196A145	Screw	X	2
14	5225973-4	Plug (90° BNC, one plug for GPS wiring, additional plugs for Com and Nav wiring; lead free)	X	A/R
	225973-4	Plug (90° BNC, one plug for GPS wiring, additional plugs for Com and Nav wiring)	X	A/R
15	MS21042L4	Nut	X	1
16	NAS1149F0432P	Washer	X	1
17	B266-8	Sleeving	X	A/R
18	C359-2	Panel – Console (Ref)		
19	NAS557-14B	Grommet	X	1
20	MS20142L08	Nut	X	4
21	NAS1149FN816P	Washer	X	4
22	D703-8	Shim	X	A/R
23	MS27039C0806	Screw	X	3
24	D704-12	Stiffener (Ref)		
25	MS21919WDG14	Clamp	X	1
26	NAS6604-2	Bolt	X	1
27	MS20470AD3	Rivet (Ref)		
28	D703-1	Support Weldment (Incl items 23 and 26)	X	1
29	C238-18	Windshield Frame – RH (Chin, Ref)		

NOTES

Continues

FIGURE AND INDEX NUMBER	PART NUMBER	DESCRIPTION	PARTS AVAIL	QTY PER ASSY
PILOT'S SIDE AVIONICS CONSOLE (Cont'd)				
97-17-30	D704-6	Bracket	X	1
31	D580-2	Fan Assembly (Incl items 32, 36 thru 38, and wires; 28-volt ships)	X	1
	D580-3	Fan Assembly (Incl items 32, 37, 38, and wires; 14-volt ships)	X	1
32	D351M-024GK-2	Fan	X	1
33	92196A108	Screw	X	8
34	5399K17	Hose	X	1
35	D704-11	Nozzle	X	1
36	SPH-330	Resistor (28-volt ships only)	X	1
37	B158-404	Heat Shrink (28-volt ships)	X	A/R
	B158-2	Heat Shrink (14-volt ships)	X	A/R
38	B158-404	Housing	X	1
	B263-1	Pin	X	2
39	GNS 430W	GPS Transceiver (Garmin)	X	1
40	GNC 420W	GPS Transceiver (Garmin)	X	1
NOTES				

Intentionally Blank

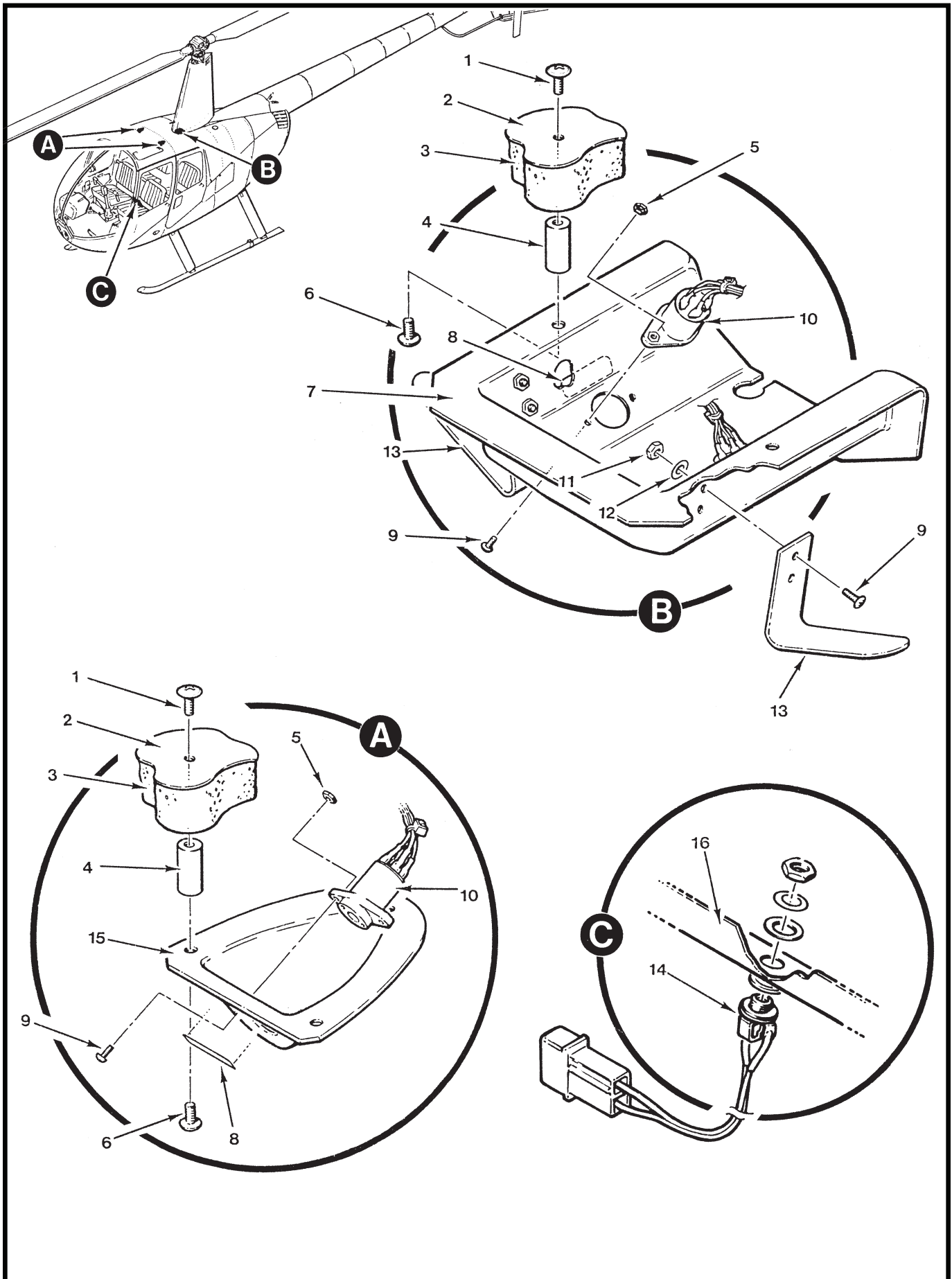

FIGURE AND INDEX NUMBER	PART NUMBER	DESCRIPTION	PARTS AVAIL	QTY PER ASSY
HEADSET JACKS				
97-21-1	AN526C832R6	Screw	X	8
2	—	Panel – Roof (Ref)		
3	—	Foam Insulation (Ref)		
4	C710-3	Spacer	X	8
5	B330-2	Palnut	X	8
6	MS27039C0805	Screw	X	8
7	A712-3	Cover	X	1
8	A654-16	Decal (“Headset”)	X	4
9	MS35206-215	Screw	X	10
10	TJ-120	Jack	X	4
11	MS21042L04	Nut	X	4
12	NAS1149FN416P	Washer	X	4
13	A752-1	Angle (headset holder)	X	2
14	C049-6	Harness Assembly (external audio input)	X	1
15	C710-1	Cover Assembly (Includes item 8)	X	2
	C710-4	Cover (headset jacks – dual, not shown)	X	2
16	C054-1	Cover (Ref; see Figure 6-7)		

NOTES

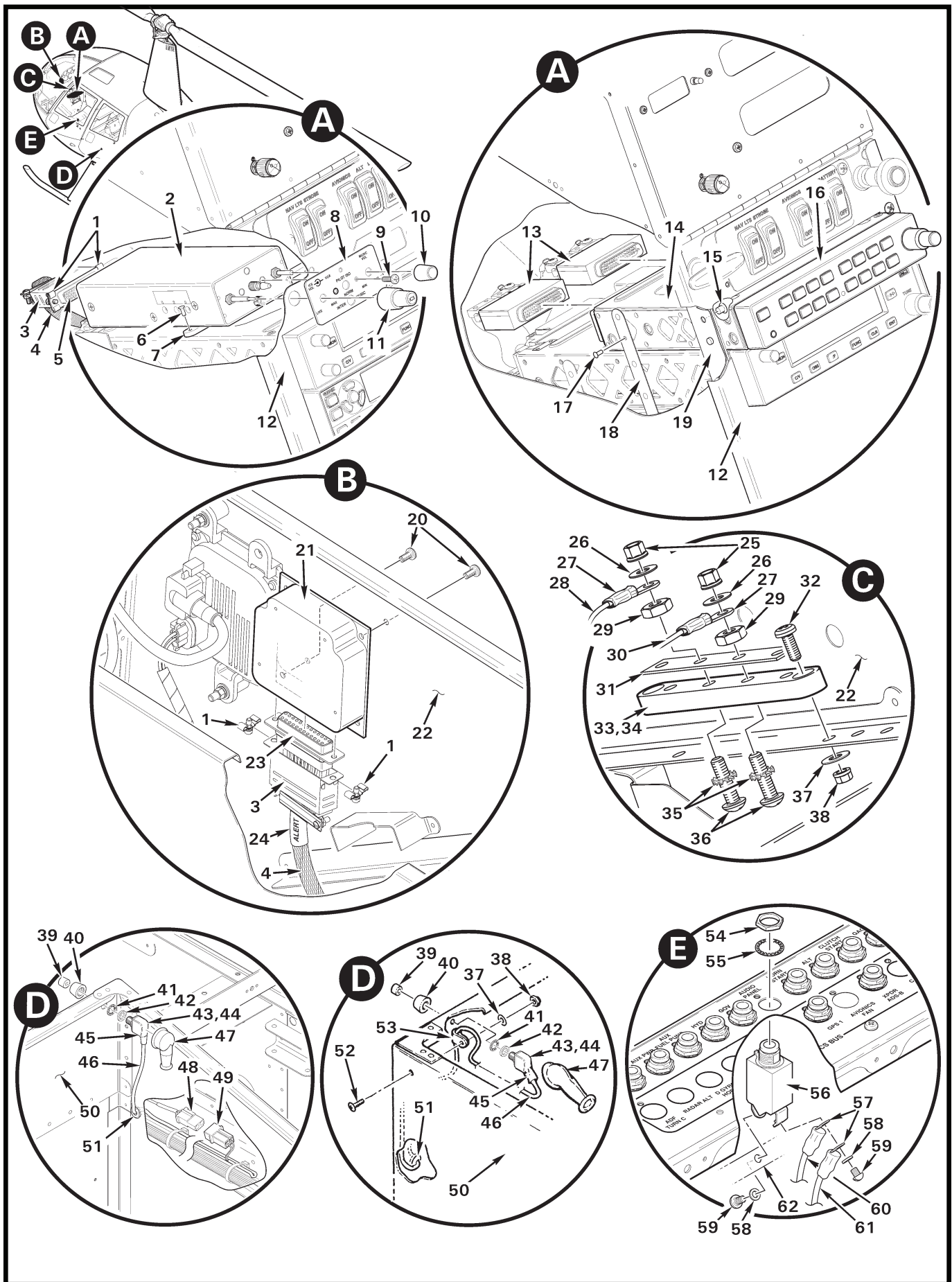

FIGURE AND INDEX NUMBER	PART NUMBER	DESCRIPTION	PARTS AVAIL	QTY PER ASSY
INTERCOM CONTROL INSTALLATION				
97-23-1	B269-31	Male Screw Lock	X	2
2	B338-2	Intercom System Unit (Includes items 8 thru 11. Contact RHC Technical Support to replace B338-1 ICS control. B338-2 control not compatible with old revision C049 harness assembly.) . .	X	1
3	B269-23	Backshell	X	2
4	B266-8	Sleeving	X	A/R
5	B269-82	Receptacle (44-socket)	X	1
	B267-5	Splice	X	1
	B267-2	Terminator (not shown)	X	7
	B267-3	Terminator (not shown)	X	5
6	MS20426AD3	Rivet	X	1
7	A736-1	Support (install using item 6)	X	2
8	50-04-832*	Faceplate	X	1
9	25-11-427	Screw	X	3
10	40-18-MUS2	Knob (small)	X	1
11	40-21-ICS3	Knob (large)	X	1
12	C641	Panel – Avionics (Ref)		
13	011-02302-00**	Connector Kit (Ref)		
14	115-0145-2-00**	Install Rack (Ref)		
15	MS20426AD5	Rivet	X	4
16	GMA350HC**	Audio Control (Incl items 13 and 14)	X	1
17	NAS1097AD3	Rivet	X	4
18	A684-1	Strap	X	2
19	C905-5	Angle	X	2
20	MS35206-227	Screw	X	2
21	F793-1	Alert Box (tone generator)	X	1
22	C033	Console Assembly – Lower (Ref)		
23	B269-12	Receptacle (25-Socket)	X	1
	B267-2	Terminator	X	2
	B267-3	Terminator	X	1
	B267-5	Splice	X	1
24	B158-8	Heat Shrink (labeled "ALERT")	X	A/R

NOTES * N.A.T. part number
 ** Garmin part number.

Continues

FIGURE AND INDEX NUMBER	PART NUMBER	DESCRIPTION	PARTS AVAIL	QTY PER ASSY
INTERCOM CONTROL INSTALLATION (Cont'd)				
97-23-25	MS21042L08	Nut	X	2
26	NAS1149FN816P	Washer	X	2
27	B260-3	Terminal	X	2
28	F859-239	Wire (Ref; ground)		
29	B301-8	Nut	X	4
30	F859-643	Wire (Ref; ground, audio control)		
31	A448-10	Bus Bar	X	1
32	MS35206-228	Screw	X	2
33	C448-2	Terminal Block Assembly (Incl items 29, 31, 35, and 36)	X	1
34	C448-5	Block (Ref)		
35	91120A130	Washer	X	4
36	B567-43	Screw	X	4
37	NAS1149FN616P*	Washer	X	2
38	MS21042L06*	Nut	X	2
39	801801000	Cap (white)	X	1
40	702501201	Dress Nut	X	1
41	B227-3	Lockwasher	X	1
42	94773A770	Washer	X	1
43	C049-10	Harness Assembly (LH and RH, includes 44 thru 48, and 51)	X	2
44	B227-8	Switch Assembly (Incl items 39 thru 42)	X	1
45	B158-8	Heat Shrink (around item 44)	X	A/R
46	B158-2	Heat Shrink (around wires)	X	A/R
47	MS25171-1S	Nipple	X	1
48	B263-12	Housing	X	1
	B263-1	Pin	X	2
49	B263-13	Housing (Ref)		
50	C291	Aft Seat Support Assembly (RH shown; Ref)		
51	MS35489-4	Grommet	X	1
52	MS35206-228*	Screw	X	2
53	7622*	Clamp	X	1
54	—	Nut	O	1

NOTES * Earlier R44s.

Continues

FIGURE AND INDEX NUMBER	PART NUMBER	DESCRIPTION	PARTS AVAIL	QTY PER ASSY
INTERCOM CONTROL INSTALLATION (Cont'd)				
97-23-55	—	Washer	O	1
56	B297-5	Circuit Breaker (2 amp; used with item 2. Includes items 54, 55, 58, and 59.)	X	1
	B297-2	Circuit Breaker (5 amp; used with item 16. Includes items 54, 55, 58, and 59.)	X	1
57	B260-2	Terminal	X	2
58	—	Washer	O	2
59	—	Screw	O	2
60	C859-2916	Wire (Ref; power, alert box)		
61	C859-644	Wire (Ref; power, items 2 and 16)		
62	A448	Bus Bar (Ref)		

NOTES

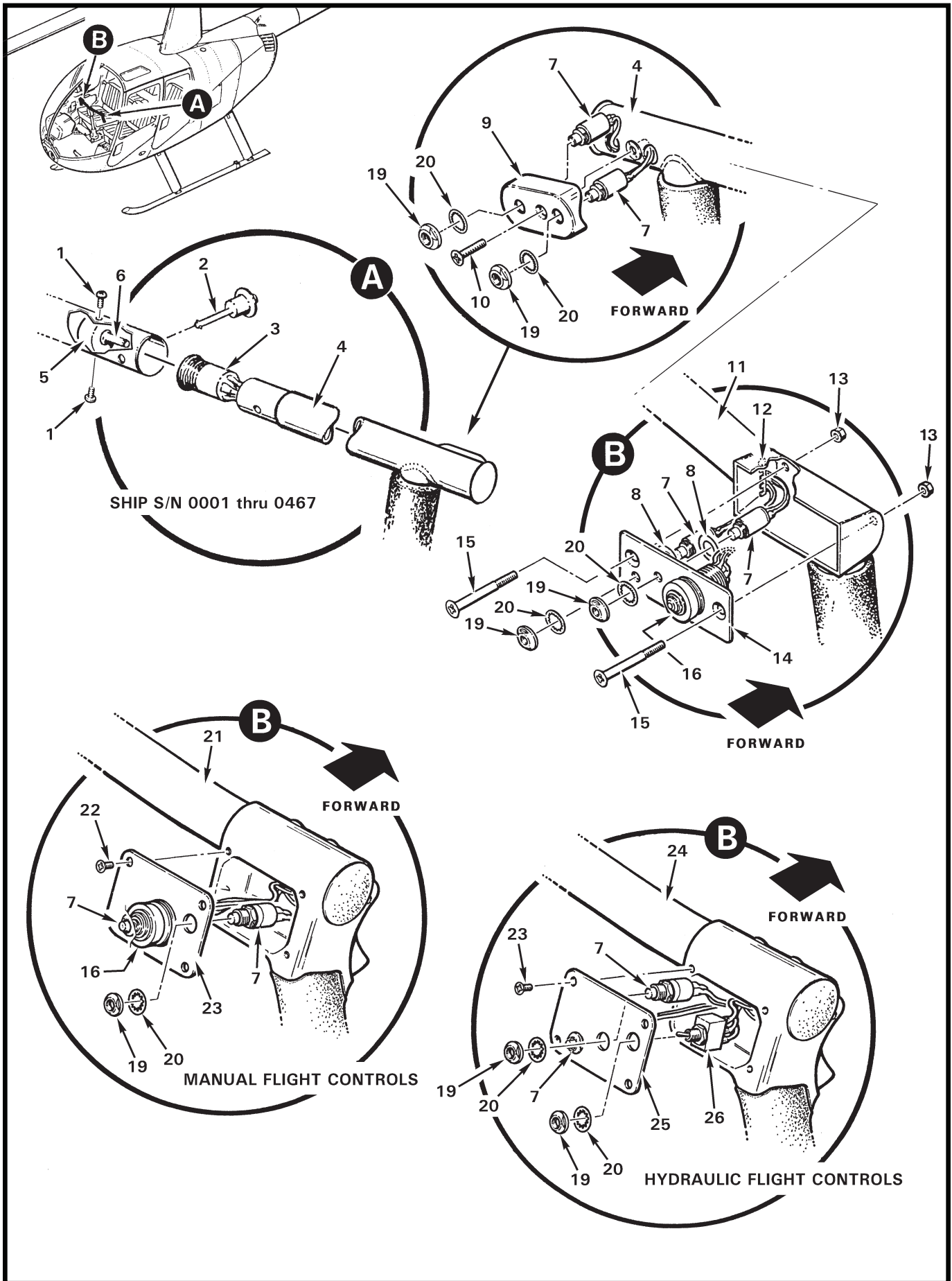

FIGURE AND INDEX NUMBER	PART NUMBER	DESCRIPTION	PARTS AVAIL	QTY PER ASSY
ICS CYCLIC GRIP SWITCHES INSTALLATION				
97-25-1	MS35206-241	Screw	X	2
2	B232-1	Handle Pin	X	1
3	TJT-120	Jack	X	1
4	A756-15*	Grip Assembly – Co-Pilot (Ref)		
5	A776-1	Mount	X	1
6	A781-1	Plug	X	1
7	B227-2	Switch Assembly (Incl items 19 and 20)	X	4
8	NAS1149F0463P	Washer	X	2
9	A216-1	Housing	X	1
10	MS24693-S51	Screw	X	1
11	A756-6*	Grip Assembly – Pilot (Ref)		
12	MS21266-1N	Grommet (install using item 17)	X	A/R
13	MS21042L08	Nut	X	2
14	C216-1	Plate	X	1
15	MS24694-S17	Screw	X	2
16	T4-0032	Switch (trim system, Ref)		
17	B270-8qt	Adhesive (one-quart can)	X	A/R
18	C058-1*	Cyclic Grip Assembly (Ref, includes items 1 thru 17; see Figure 67-1)		
19	B227-4	Dress Nut	X	1
20	B227-3	Lockwasher	X	1
21	C058-1	Grip Assembly – Pilot/Co-Pilot (Ref, Manual Flight Controls. Includes item 23. See also Figure 67-11.)		
22	MS24693-S2	Screw	X	8
23	C214-7	Plate	X	1
24	C058-7	Grip Assembly – Pilot/Co-Pilot (Ref, Hydraulic Flight Controls. Includes item 25. See also Figure 67-11.)		
25	C214-10	Plate	X	1
26	B300-3	Switch – Hydraulic (Ref; see Figure 67-11)		

NOTES * Ship S/N 0001 thru 0467.

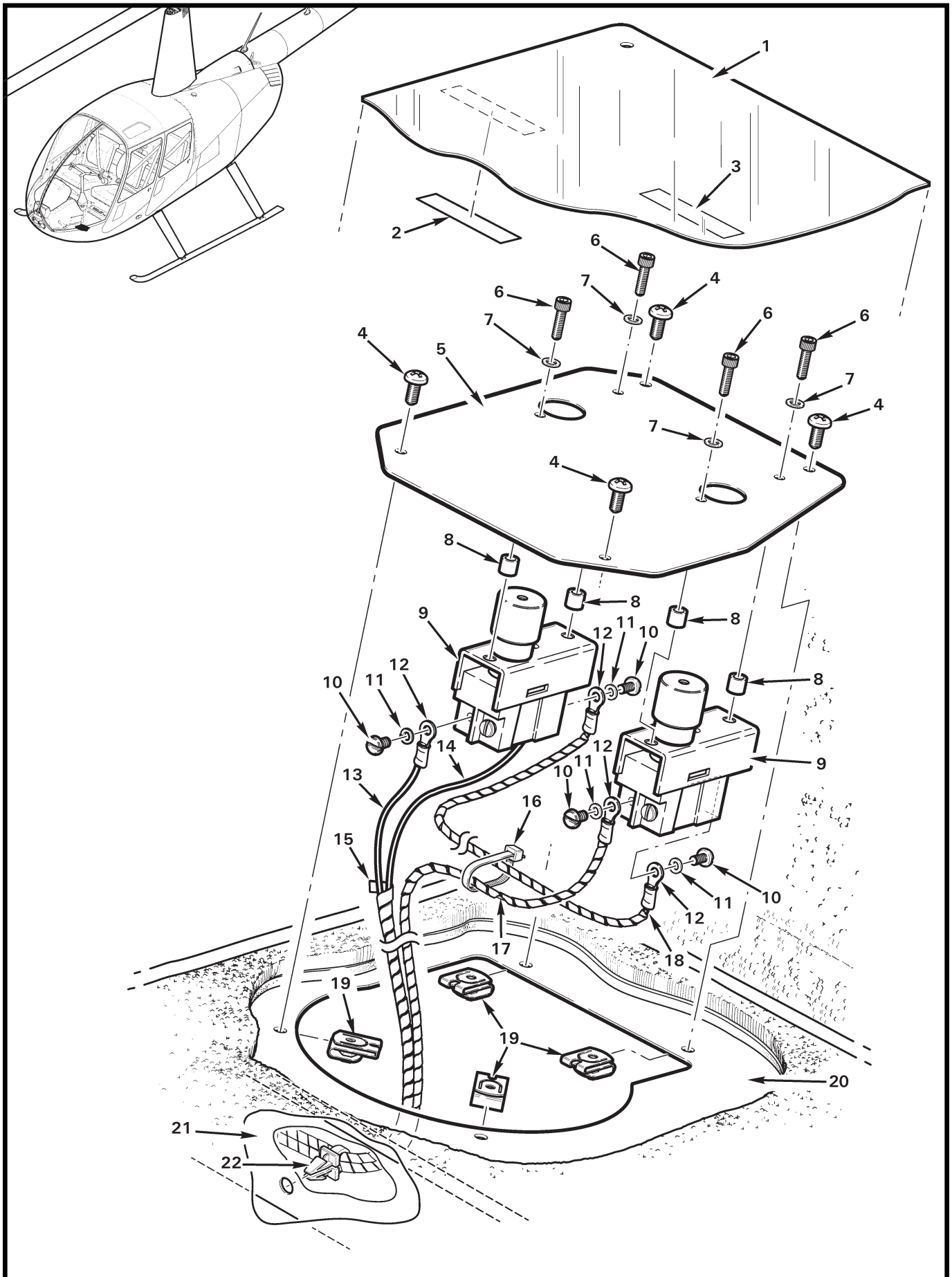

FIGURE AND INDEX NUMBER	PART NUMBER	DESCRIPTION	PARTS AVAIL	QTY PER ASSY
ICS FLOOR SWITCH INSTALLATION				
97-27-1	C469	Scuff Plate (LH, Ref)		
2	C654-30	Decal – “Intercom”	X	1
3	C654-31	Decal – “Transmit”	X	1
4	MS27039C0806	Screw	X	4
5	C797-1	Cover	X	1
6	NAS1351-06-8P	Screw (or AN502-6-8)	X	4
7	NAS620-6	Washer	X	4
8	A130-36	Spacer	X	4
9	A565-2	Switch – Foot (Incl items 10 and 11)	X	2
10	—	Screw	O	3
11	—	Lockwasher	O	3
12	B260-2	Terminal	X	5
13	C059-283	Wire (Ref)		
14	C059-284	Wire (Ref)		
15	B161-2	Spirap	X	A/R
16	MS3367-5-9	Ty-Rap	X	A/R
17	C060-686	Wire (Ref)		
18	C060-687	Wire (Ref)		
19	B162-3	Clipnut	X	4
20	C232-3	Panel – Floor (LH, Ref)		
21	C407-2	Beam (Ref, under item 20)		
22	220-242400-09	Clip	X	1

NOTES

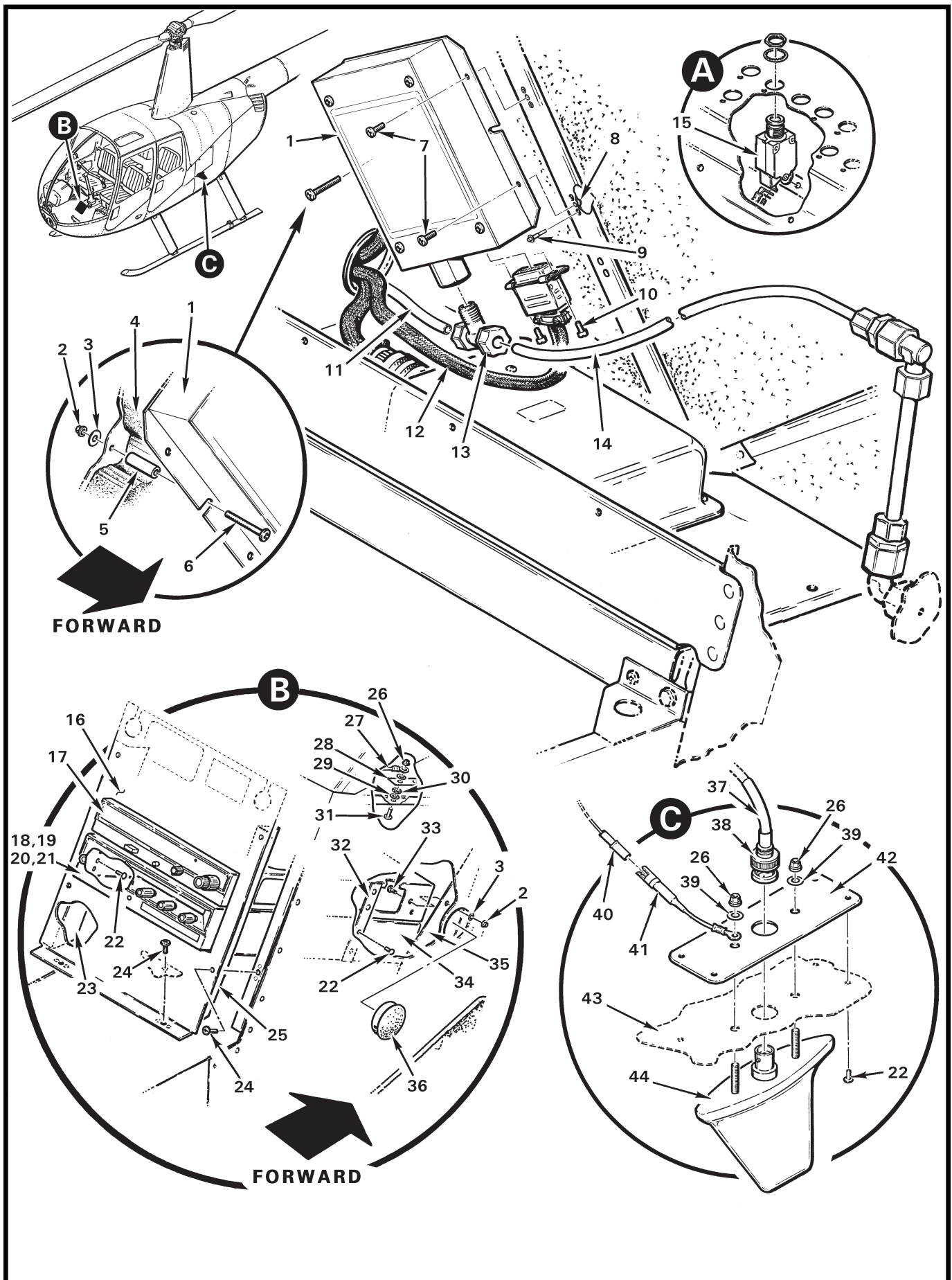

FIGURE AND INDEX NUMBER	PART NUMBER	DESCRIPTION	PARTS AVAIL	QTY PER ASSY
		TRANSPONDER AND BLIND ENCODER		
97-29-1	B240-2	Blind Encoder (solid state)	X	1
2	MS21042L06	Nut	X	3
3	NAS1149FN616P	Washer	X	3
4	C003	Insulation – Foam (Ref)		
5	A130-31	Spacer	X	1
6	MS35206-328	Screw	X	1
7	MS35206-215	Screw	X	2
8	MS21069L04	Nutplate	X	2
9	MS20605R3W2	Rivet	X	2
10	—	Screw	O	2
11	A729-23	Tube (Ref, see Figure 95-27)		
12	B241-3	Wire Harness (Incl item 10)	X	1
13	60-4-2-N-0	Tee	X	1
14	A729-12	Tube (Ref, see Figure 95-27)		
15	B297-2	Circuit Breaker (2-amp, use with items 18 and 19 [28-volt ships])	X	1
	B297-3	Circuit Breaker (3-amp, use with item 21)	X	1
	B297-5	Circuit Breaker (5-amp, use with items 19 [14-volt ships] and item 20)	X	1
16	C641	Panel – Avionics (Ref)		
17	KY 197A	Com Transceiver (Bendix/King, Ref)		
18	KT 76A	Transponder (Bendix/King, Ref)		
19	KT 76C	Transponder (Bendix/King; not shown)		
20	KT 70	Transponder (Bendix/King; not shown)		
21	GTX327	Transponder (Garmin; not shown)		
22	MS20470AD3	Rivet	X	10
23	C905-1	Angle (LH)	X	1
24	MS27039C0806	Screw (Ref)		
25	C905-2	Angle (RH)	X	1
26	MS21042L08	Nut	X	1
27	-260	Wire (Ref)		
28	A448-15	Bus Bar (3-hole)	X	1

NOTES

Continues

FIGURE AND INDEX NUMBER	PART NUMBER	DESCRIPTION	PARTS AVAIL	QTY PER ASSY
TRANSPONDER AND BLIND ENCODER (Cont'd)				
97-29-29	NAS1149DN832H	Washer	X	1
30	AN340B8	Nut	X	1
31	AN515UB8R10	Screw	X	1
32	A684-1	Strap	X	2
33	—	Screw (supplied with radio)	O	2
34	—	Tray (supplied with transponder)	O	1
35	A371-2	Stiffener (RH)	X	1
	A371-1	Stiffener (LH, not shown)	X	1
36	DP-1250	Hole Plug	X	2
37	C850-264	Cable (Ref)		
38	225395-6**	Plug	X	1
39	NAS1149FN816P	Washer	X	2
40	B263-11	Housing	X	1
	B263-2	Socket	X	1
41	B263-10	Housing	X	1
	B263-1	Pin	X	1
42	B10567	Doubler	O	1
43	C794	Panel (Ref; see Figure 6-13)	O	1
44	CI-105-16*	Antenna – Transponder (Ref; alternate part no. KA 60**) . . .	X	1

NOTES * Comant Industries part no.
 ** Honeywell Bendix/King part no.

Intentionally Blank

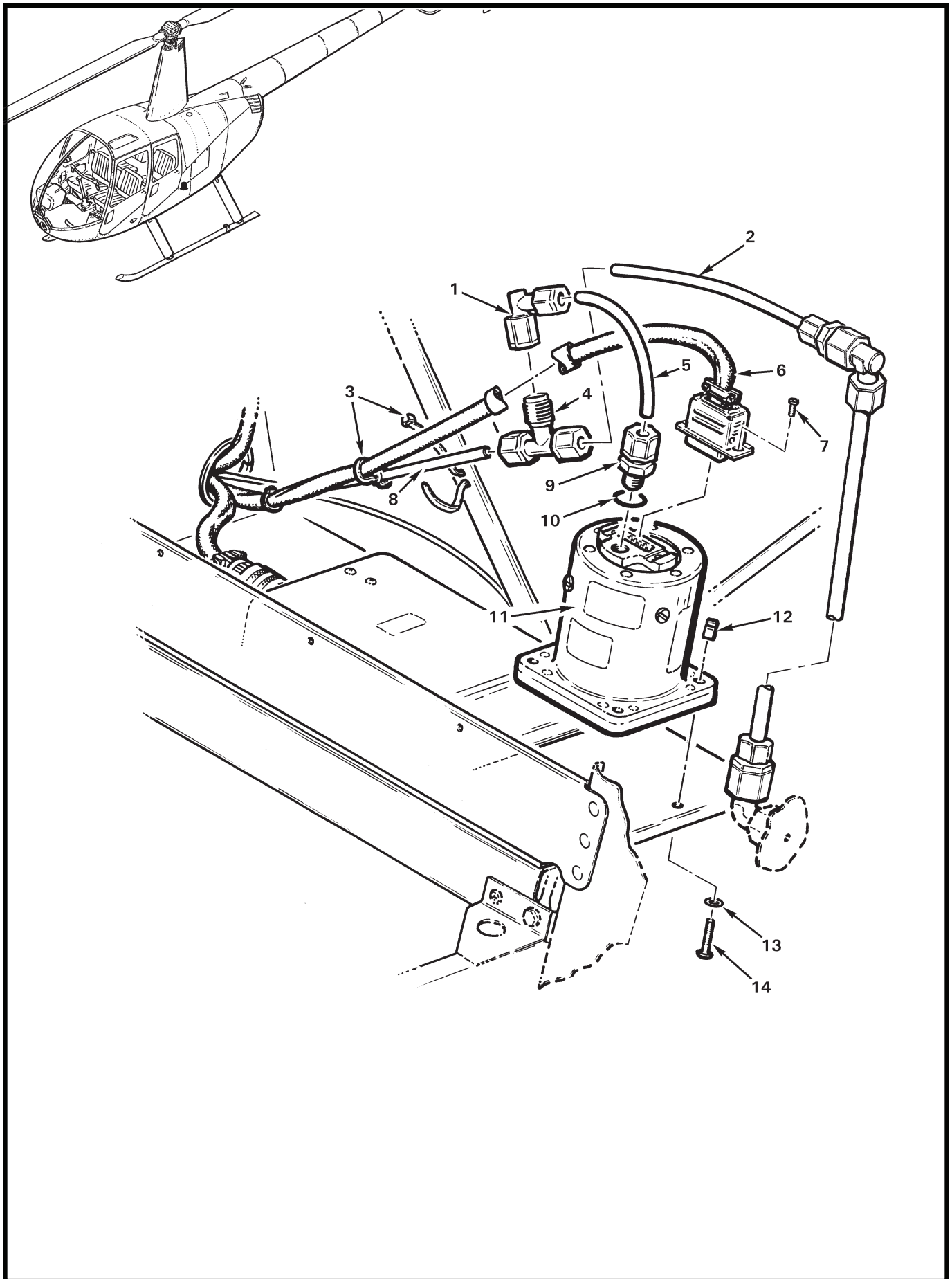

FIGURE AND INDEX NUMBER	PART NUMBER	DESCRIPTION	PARTS AVAIL	QTY PER ASSY
BLIND ENCODER INSTALLATION				
97-33-1	45-4-2-N-0	Elbow	X	1
2	A729-12	Tube (Ref, see Figure 95-49)		
3	MS3367-5-9	Ty-Rap	X	A/R
4	60-4-2-N-0	Tee	X	1
5	A729-25	Tube	X	1
6	B241-3	Wire Harness (Incl item 15)	X	1
7	—	Screw	O	2
8	A729-23	Tube (Ref, see Figure 95-49)		
9	10-4-2-N-0	Fitting	X	1
10	A215-204	O-Ring	X	1
11	B240-2	Blind Encoder (Ref, no longer available. Contact RHC Customer Service for replacement.)		
12	MS33737-16C	Instrument Nut	X	4
13	NAS1149FN616P	Washer	X	1
14	MS35206-232	Screw	X	4
NOTES				

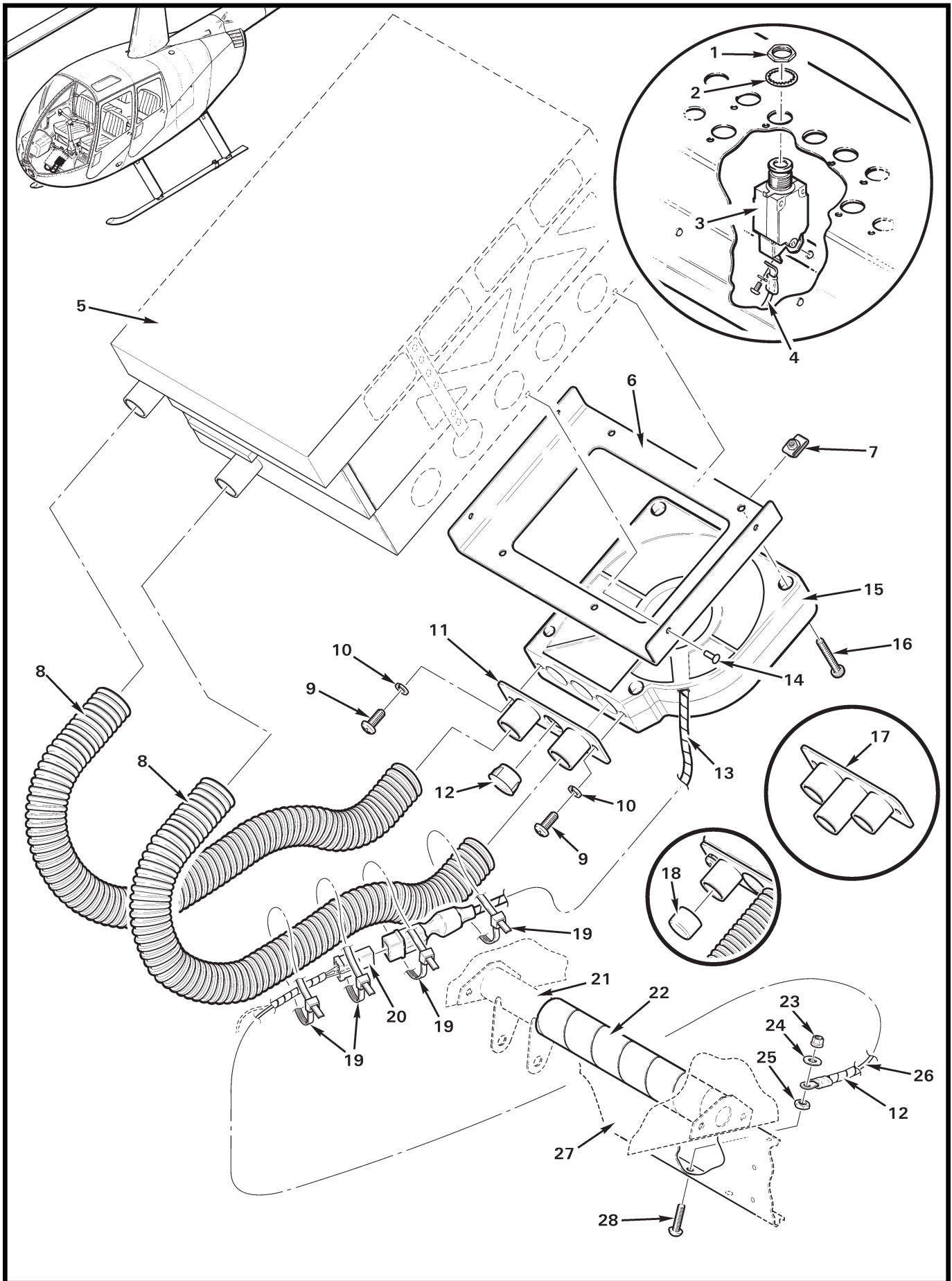

FIGURE AND INDEX NUMBER	PART NUMBER	DESCRIPTION	PARTS AVAIL	QTY PER ASSY
AVIONICS BLOWER INSTALLATION				
97-35-1	—	Nut	O	1
2	—	Lockwasher	O	1
3	B297-2	Circuit Breaker (2-amp, includes items 1 and 2)	X	1
4	—	Wire (Ref, no. 1014; power)		
5	—	Radio Tray (Ref)		
6	D561-8	Bracket (attach to bottom of item 5)	X	1
7	B162-1	Clipnut	X	4
8	5399K17	Hose	X	A/R
9	MS27039C0807	Screw	X	2
10	B332-42	Lockwasher	X	2
11	D561-3	Outlet Assembly (2-hose, includes item 12; for 1 hose installation order item 18 to cover unused outlet.)	X	A/R
12	2663	Hole plug	X	A/R
13	B161-2	Spirap	X	A/R
14	MS20470AD3	Rivet	X	4
15	D561-9	Blower Assembly (14-volt ships; includes connector, wires, heat shrink, etc., as shown.)	X	1
	D561-10	Blower Assembly (28-volt ships; includes connector, wires, heat shrink, etc., as shown.)	X	1
16	MS35206-235	Screw	X	4
17	D561-4	Outlet Assembly (3-hose)	X	A/R
18	A959-8	Cap – Avionics Blower	X	1
19	MS3367-4-9	Ty-Rap	X	A/R
20	B263-13	Housing (wire no.[s] 1014 and 1761)	X	1
	B263-2	Socket	X	2
21	C349-1	Support Assembly (Ref)		
22	B161-12	Spirap	X	A/R
23	MS21042L08	Nut	X	1
24	NAS1149DN832H	Washer (aluminum)	X	1
25	B301-8	Nut (Brass)	X	1
26	—	Wire (Ref, no. 1761; ground)		
27	C407-2	Beam (Ref)		
28	AN515UB8R10	Screw	X	1

NOTES

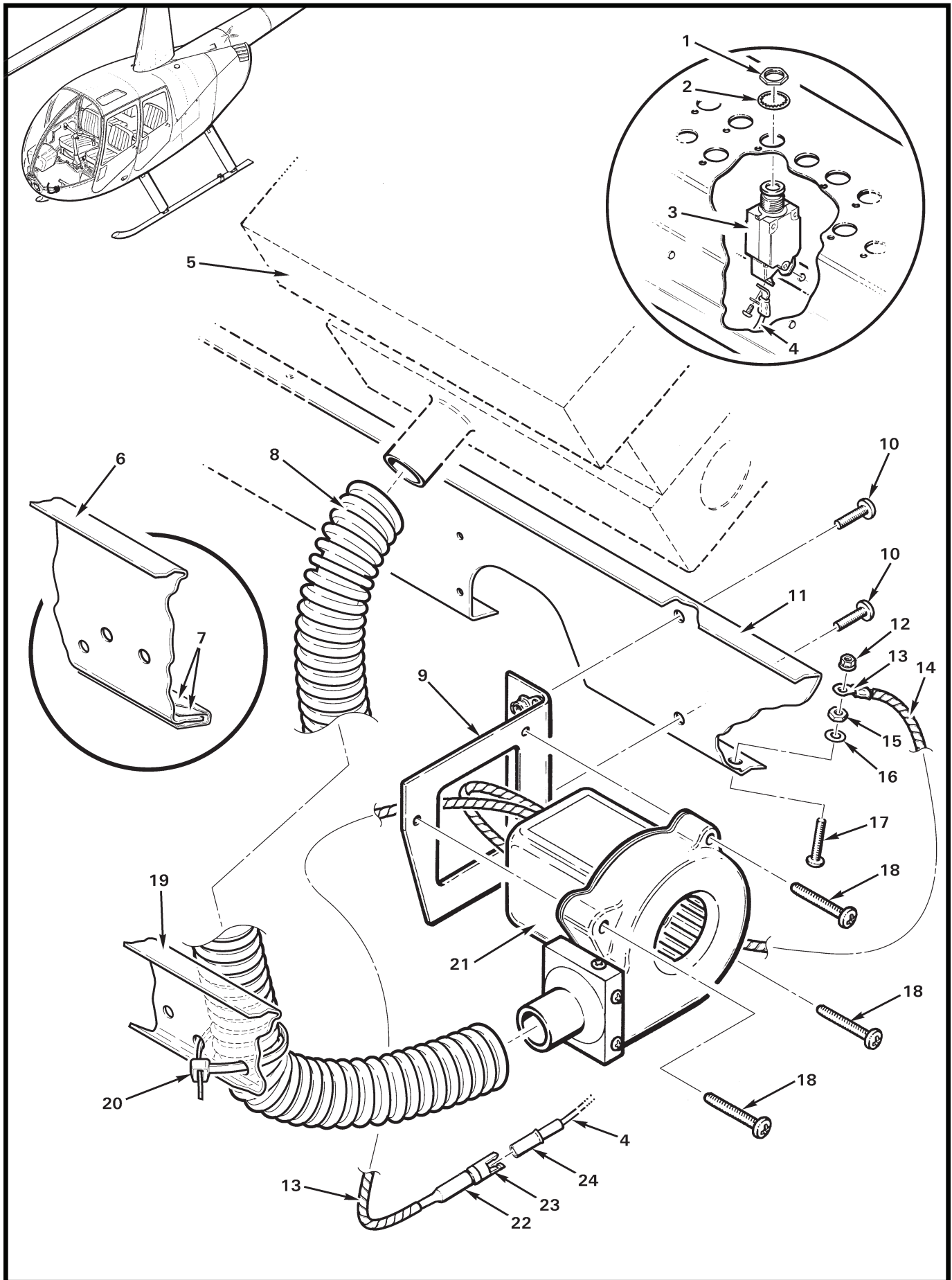

FIGURE AND INDEX NUMBER	PART NUMBER	DESCRIPTION	PARTS AVAIL	QTY PER ASSY
AVIONICS BLOWER INSTALLATION				
97-37-1	—	Nut	O	1
2	—	Lockwasher	O	1
3	B297-2	Circuit Breaker (2-amp, includes items 1 and 2)	X	1
4	—	Wire (Ref, no. 1014; power)		
5	—	Radio Tray (Ref)		
6	A406-2	Beam (Ref, large height; earlier R44s)		
7	A701-1	Tape – Foil (2 layers around edge of lower flange as shown. Used only with item 6.)	X	A/R
8	5399K17	Hose	X	A/R
9	D561-1	Bracket	X	1
10	MS27039C0806	Screw	X	2
11	C407-2	Beam (Ref)		
12	MS21042L08	Nut	X	1
13	B260-3	Terminal (ground wire)	X	1
14	B161-2	Spirap	X	A/R
15	B301-8	Nut	X	1
16	NAS1149DN832H	Washer (aluminum)	X	1
17	AN515UB8R10	Screw	X	1
18	MS35206-234	Screw	X	3
19	A406-9	Beam (Ref, small height)		
20	MS3367-7-9	Ty-Rap	X	1
21	TB1-1.5SD	Blower Assembly (14-volt; includes wires)	X	1
	TB1-1.5D	Blower Assembly (28-volt; includes wires)	X	1
22	B158-406	Heat Shrink (28-volt ships only)	X	A/R
23	B263-10	Housing	X	1
	B263-1	Pin	X	1
24	B263-11	Housing	X	1
	B263-2	Socket	X	1

NOTES

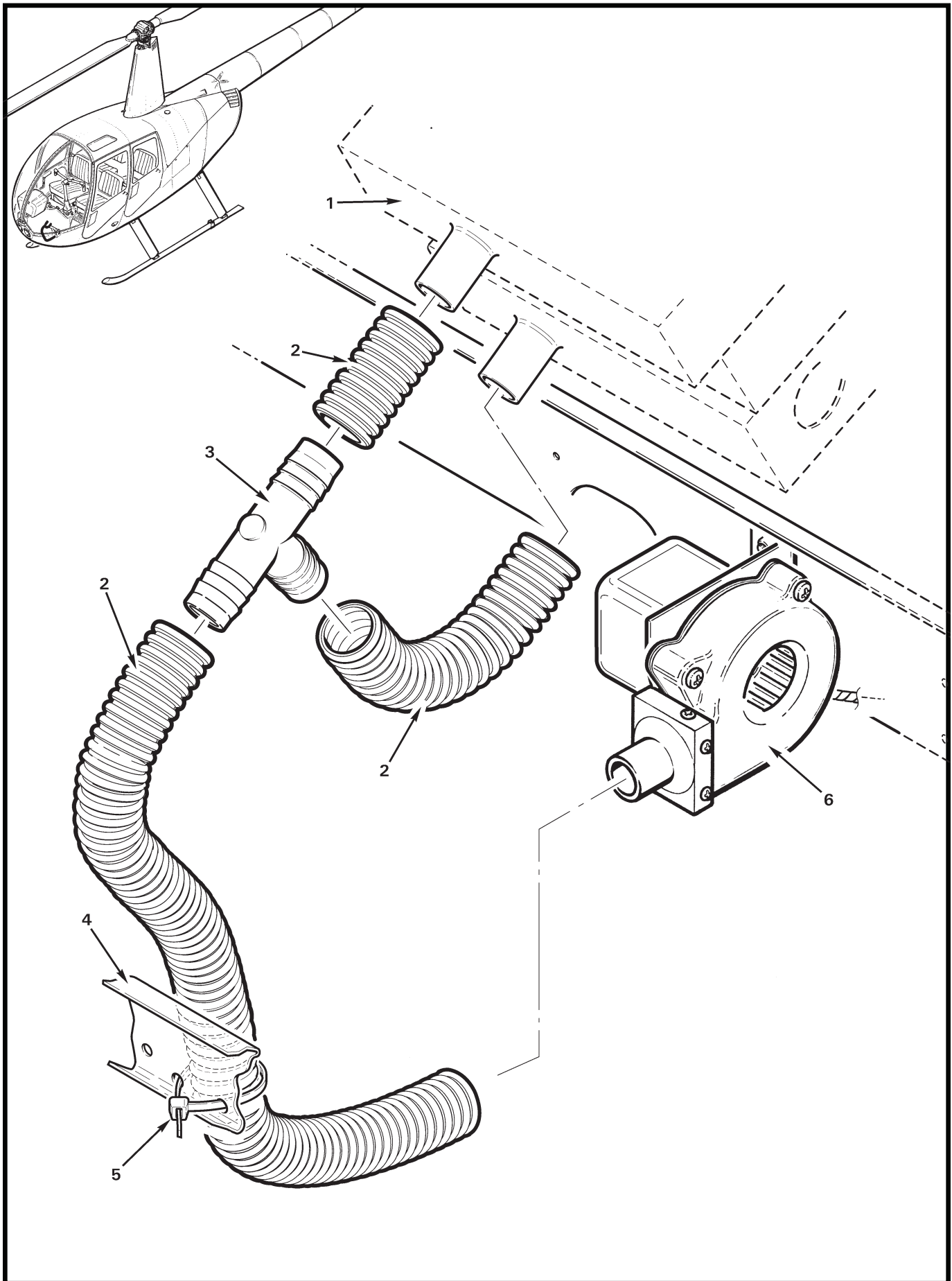

FIGURE AND INDEX NUMBER	PART NUMBER	DESCRIPTION	PARTS AVAIL	QTY PER ASSY
AVIONICS BLOWER INSTALLATION				
97-39-1	—	Radio Tray (Ref)		
2	5399K17	Hose	X	A/R
3	0715T-028	Tee	X	1
4	A406	Beam (Ref)		
5	MS3367-7-9	Ty-Rap	X	1
6	—	Blower Assembly (Ref, see Figure 97-37)		
NOTES				

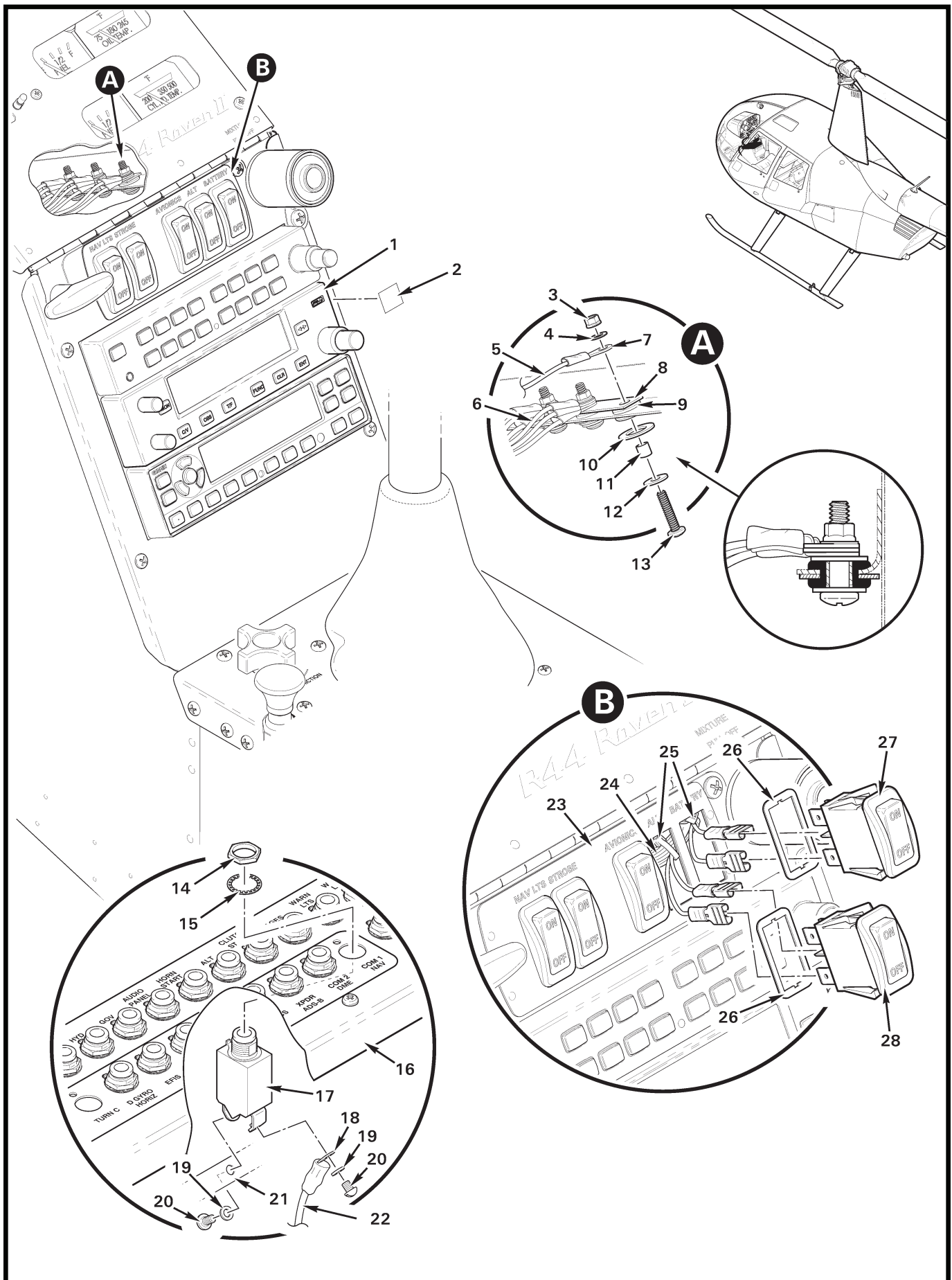

FIGURE AND INDEX NUMBER	PART NUMBER	DESCRIPTION	PARTS AVAIL	QTY PER ASSY
C802-2 COM RADIO INSTALLATION				
97-41-1	GTR 225B*	Transceiver (VHF COMM)	X	1
2	F654-38	Decal ("No. 1 COM, No. 2 COM, No. 3 COM")	X	A/R
3	MS21042L06	Nut	X	1
4	NAS620-6L	Washer	X	1
5	C802-201	Wire (Ref; ground)		
6	C802-704	Wire (Ref; for use with second COM)		
7	B260-3	Terminal	X	2
8	A448-15	Bus Bar (3-hole)	X	1
9	MS35489-4	Grommet	X	1
10	NAS1149F0532P	Washer (install in grommet groove; see detail showing parts assembled)	X	1
11	C130-59	Spacer (install in grommet bore; see detail showing parts assembled)	X	1
12	NAS1149FN632P	Washer	X	1
13	B567-28	Screw	X	2
14	—	Nut	O	1
15	—	Lockwasher	O	1
16	C490	Panel Assembly – Circuit Breaker (Ref)		
17	C297-5	Circuit Breaker (5 amp, 28-volt ships; includes items 14, 15, 19, & 20)	X	1
	C297-10	Circuit Breaker (10 amp, 14-volt ships; includes items 14, 15, 19, & 20)	X	1
18	B260-2	Terminal	X	1
19	—	Washer	O	2
20	—	Screw	O	2
21	A448	Bus Bar (Ref)		
22	C859-200	Wire (Ref; or C859-703 if item 1 is the second COM)		
23	F641-4	Cover	X	1
	F641-5	Cover (optional, not shown)	X	1
24	D049-6	Harness Assembly (Ref)		
25	MS3367-4-9	Ty-Rap (Ref)		
26	G184-5	Gasket	X	5
27	G184-2	Switch	X	1
28	G184-1	Switch	X	4

NOTES * Garmin part no.

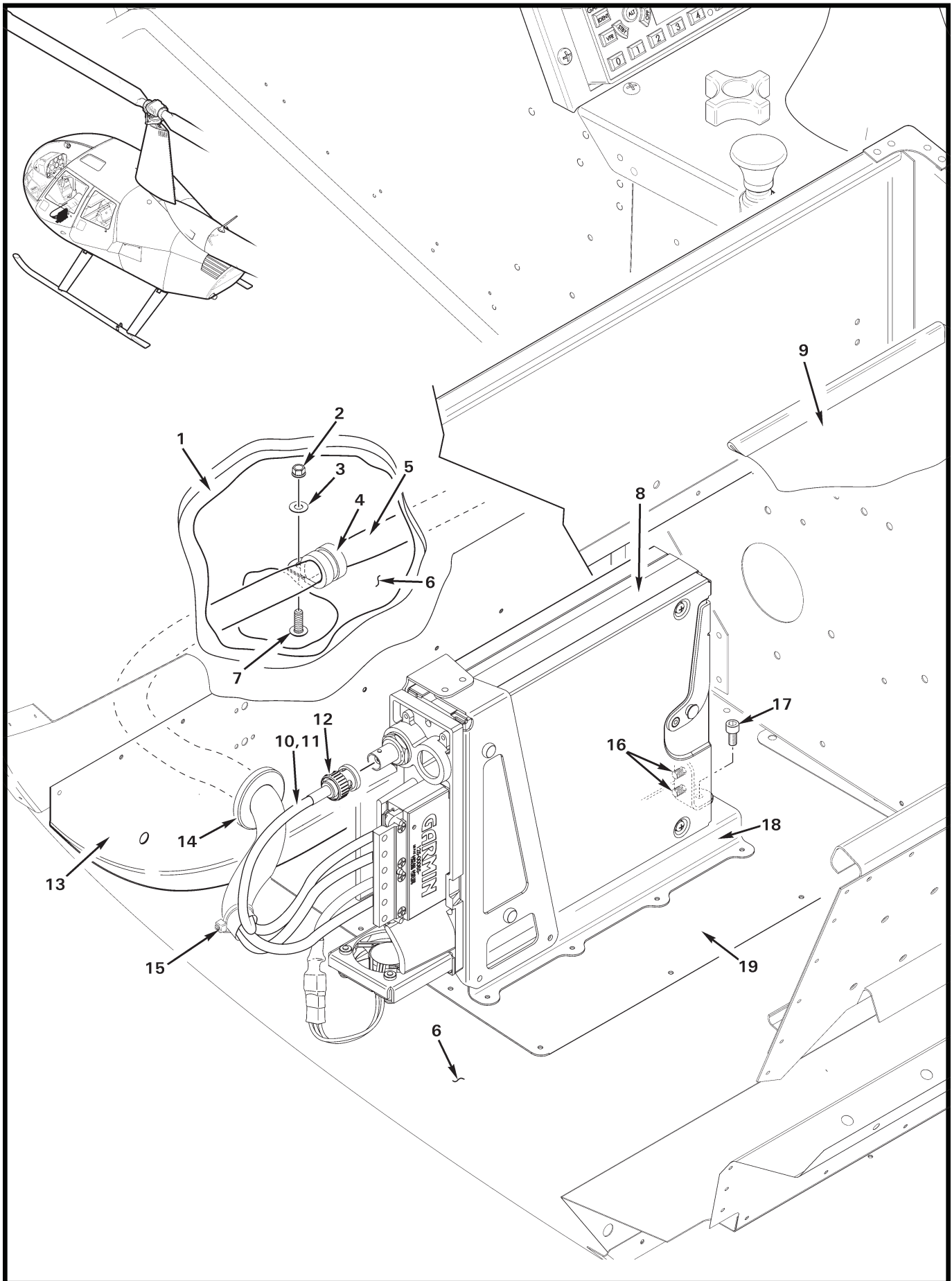

FIGURE AND INDEX NUMBER	PART NUMBER	DESCRIPTION	PARTS AVAIL	QTY PER ASSY
C803-1 ADS-B INSTALLATION				
97-43-1	C232-3	Panel (Ref, shown with carpet)		
2	MS21042L08	Nut	X	1
3	NAS1149FN816P	Washer	X	1
4	MS21919WDG8	Clamp	X	1
5	B161-8	Sleeving	X	A/R
6	C272-1	Chin (Ref)		
7	AN526C832R8	Screw	X	1
8	GDL 88*	Receiver (ADS-B)	X	1
9	C748-5	Cover Assembly (Ref)		
10	F850-452	Cable (Ref)		
11	B161-4	Sleeving	X	A/R
12	5225395-6	Plug (BNC)	X	1
13	D230-1	Bulkhead (Ref)		
14	MS35489-19	Grommet	X	1
15	MS3367-4-9	Ty-Rap (or MS3367-5-9)	X	1
16	—	Screw (supplied with item 8)	O	2
17	NAS1352-08-6P	Screw	X	1
18	C904-1	Mount Assembly (Ref)		
19	D130-1	Doubler (Ref)		

NOTES * Garmin part no.

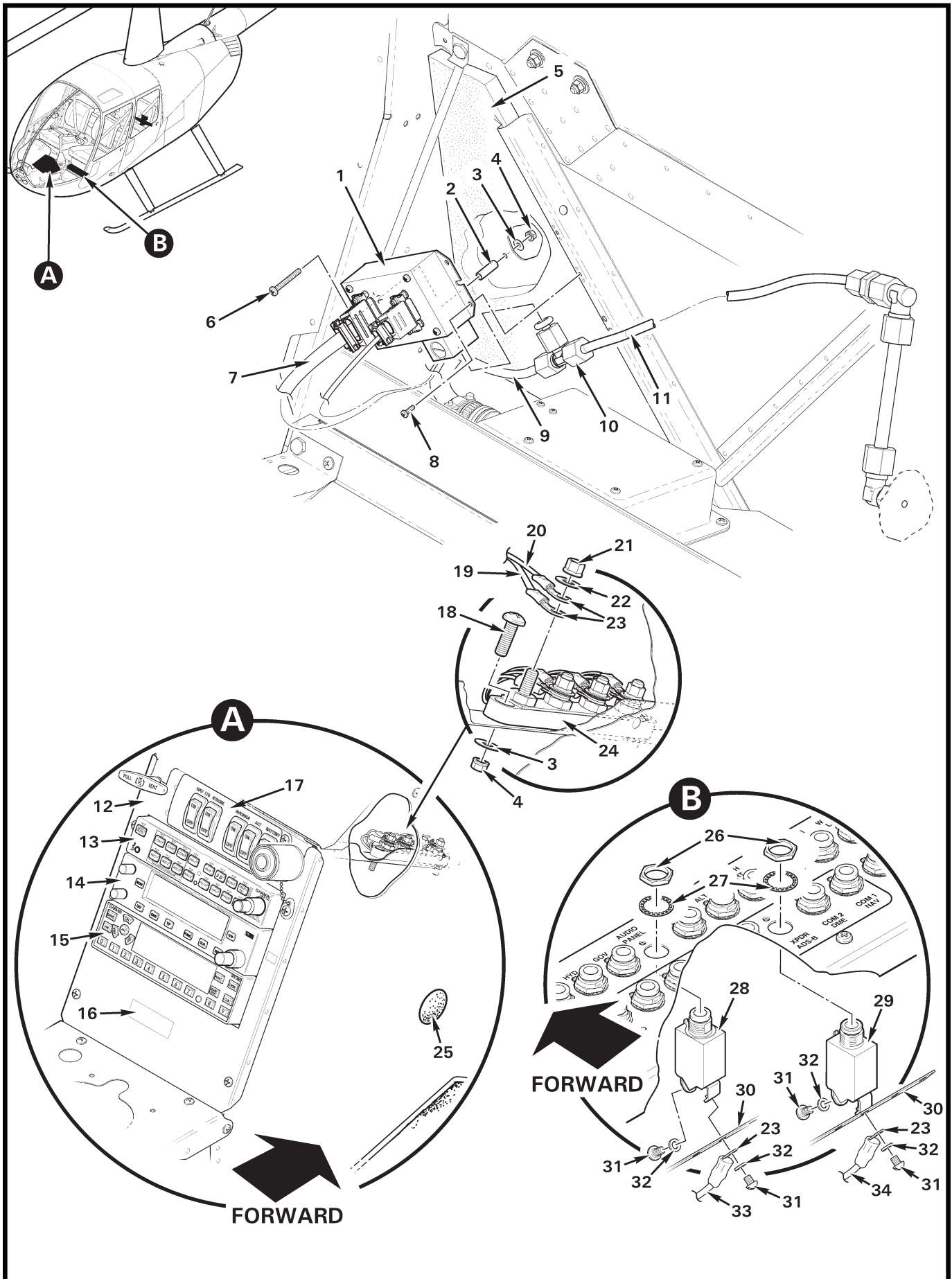

FIGURE AND INDEX NUMBER	PART NUMBER	DESCRIPTION	PARTS AVAIL	QTY PER ASSY
		GARMIN GTX 325, 335 AND 345 TRANSPONDER & BLIND ENCODER		
97-45-1	B240-3	Blind Encoder	X	1
2	A130-31	Spacer	X	1
3	NAS1149FN616P	Washer	X	2
4	MS21042L06	Nut	X	2
5	C003	Insulation – Foam (Ref)		
6	MS35206-328	Screw	X	1
7	C849	Wire Harness	X	1
8	MS35206-215	Screw	X	2
9	A729-23	Tube (Ref)		
10	60-4-2-N-0	Tee	X	1
11	A729-12	Tube (Ref)		
12	C640	Panel – Avionics (Ref)		
13	GMA 350HC*	Audio Control	X	1
14	GTR 225*	Transceiver (Ref)		
15	GTX 325*	Transponder (Mode “C”)	X	1
	GTX 335*	Transponder (Mode “S” and ADS-B Out)	X	1
	GTX 345*	Transponder (Mode “S” and ADS-B In/Out)	X	1
16	F654-37	Decal – “ADS-B OUT INSTALLED”	X	1
17	F641-4	Cover – Switches (Ref, see Figure 97-41)		
18	MS35206-228	Screw	X	1
19	-260	Wire (Ref)		
20	-643	Wire (Ref)		
21	MS21042L08	Nut	X	1
22	NAS1149FN816P	Washer	X	1
23	B260-3	Terminal (Ref)		
24	C444	Block Assembly (Ref)		
25	SI413	Hole Plug	X	2
26	—	Nut	O	2
27	—	Lockwasher	O	2
28	B297-5	Circuit Breaker (5 amp; includes items 26, 27, 31 and 32) . .	X	1
29	B297-3	Circuit Breaker (3 amp; includes items 26, 27, 31, and 32) . .	X	2
30	A448-1	Bus Bar (Ref)		
31	—	Screw	O	2
32	—	Washer	O	2
33	-644	Wire (Ref)		
34	-263	Wire (Ref)		

NOTES * Garmin part no.

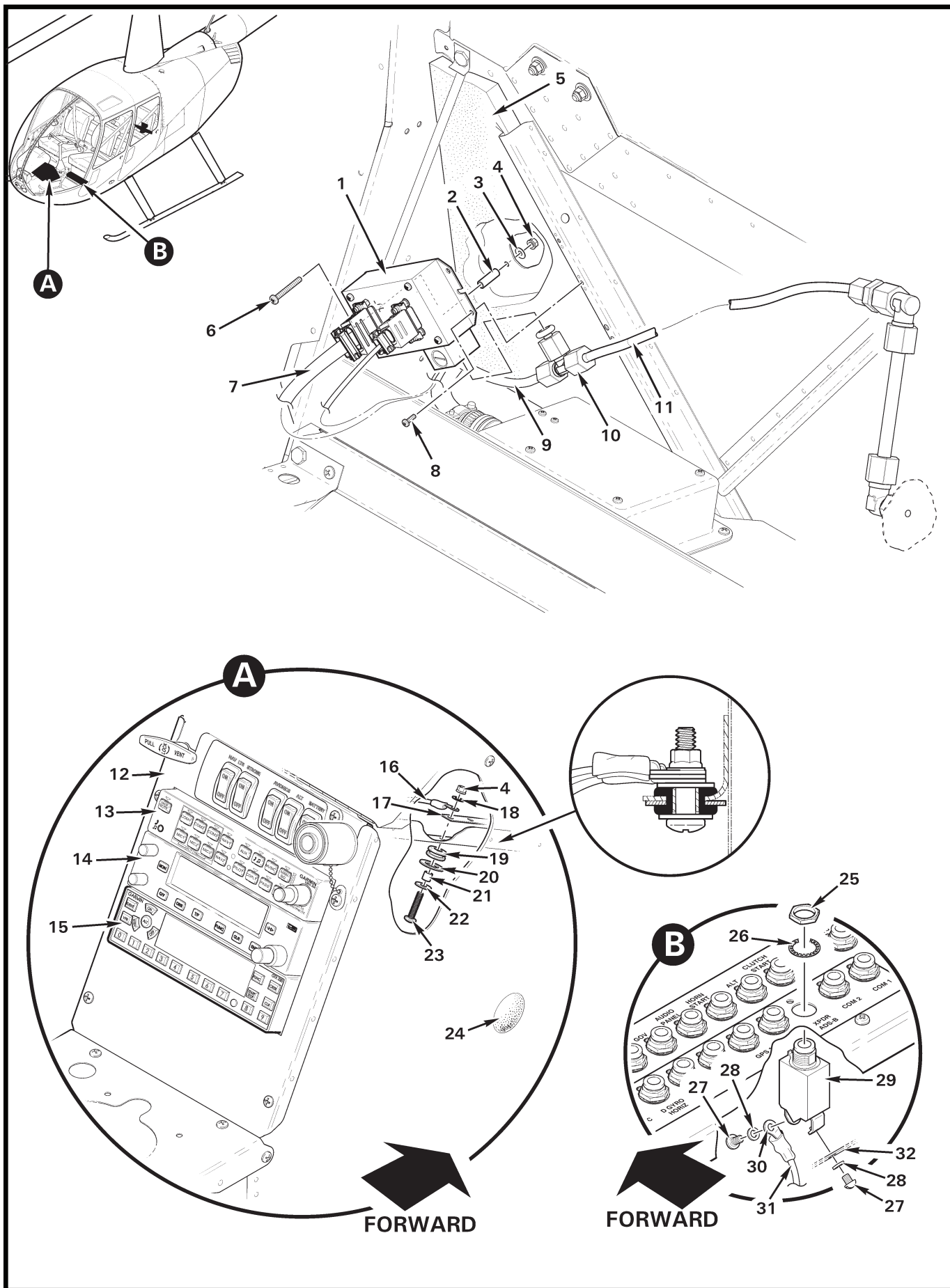

FIGURE AND INDEX NUMBER	PART NUMBER	DESCRIPTION	PARTS AVAIL	QTY PER ASSY
C804-15 TRANSPONDER INSTALLATION				
97-47-1	B240-3	Blind Encoder	X	1
2	A130-31	Spacer	X	1
3	NAS1149FN616P	Washer	X	1
4	MS21042L06	Nut	X	1
5	C003	Insulation – Foam (Ref)		
6	MS35206-328	Screw	X	1
7	B241-3	Wire Harness	X	1
8	MS35206-215	Screw	X	2
9	A729-23	Tube (Ref)		
10	60-4-2-N-0	Tee	X	1
11	A729-12	Tube (Ref)		
12	C640	Panel – Avionics (Ref)		
13	GMA 350H*	Audio Control (Ref)		
14	GTR 225*	Transceiver (Ref)		
15	GTX 330*	Transponder (Mode “S” and ADS-B Out)	X	1
16	-260	Wire (Ref)		
17	A448-15	Bus Bar (3-hole)	X	1
18	NAS620-6L	Washer	X	1
19	MS35489-4	Grommet	X	1
20	NAS1149F0532P	Washer (install in grommet groove; see detail showing parts assembled)	X	1
21	C130-59	Spacer (install in grommet bore; see detail showing parts assembled)	X	1
22	NAS1149FN632P	Washer	X	1
23	B567-28	Screw	X	1
24	SI413	Hole Plug	X	2
25	—	Nut	O	2
26	—	Lockwasher	O	2
27	—	Screw	O	2
28	—	Washer	O	2
29	B297-5	Circuit Breaker (5 amp; includes items 25 thru 28)	X	2
30	B260-3	Terminal (Ref)		
31	-263	Wire (Ref)		
32	A448-1	Bus Bar (Ref)		

NOTES * Garmin part no.

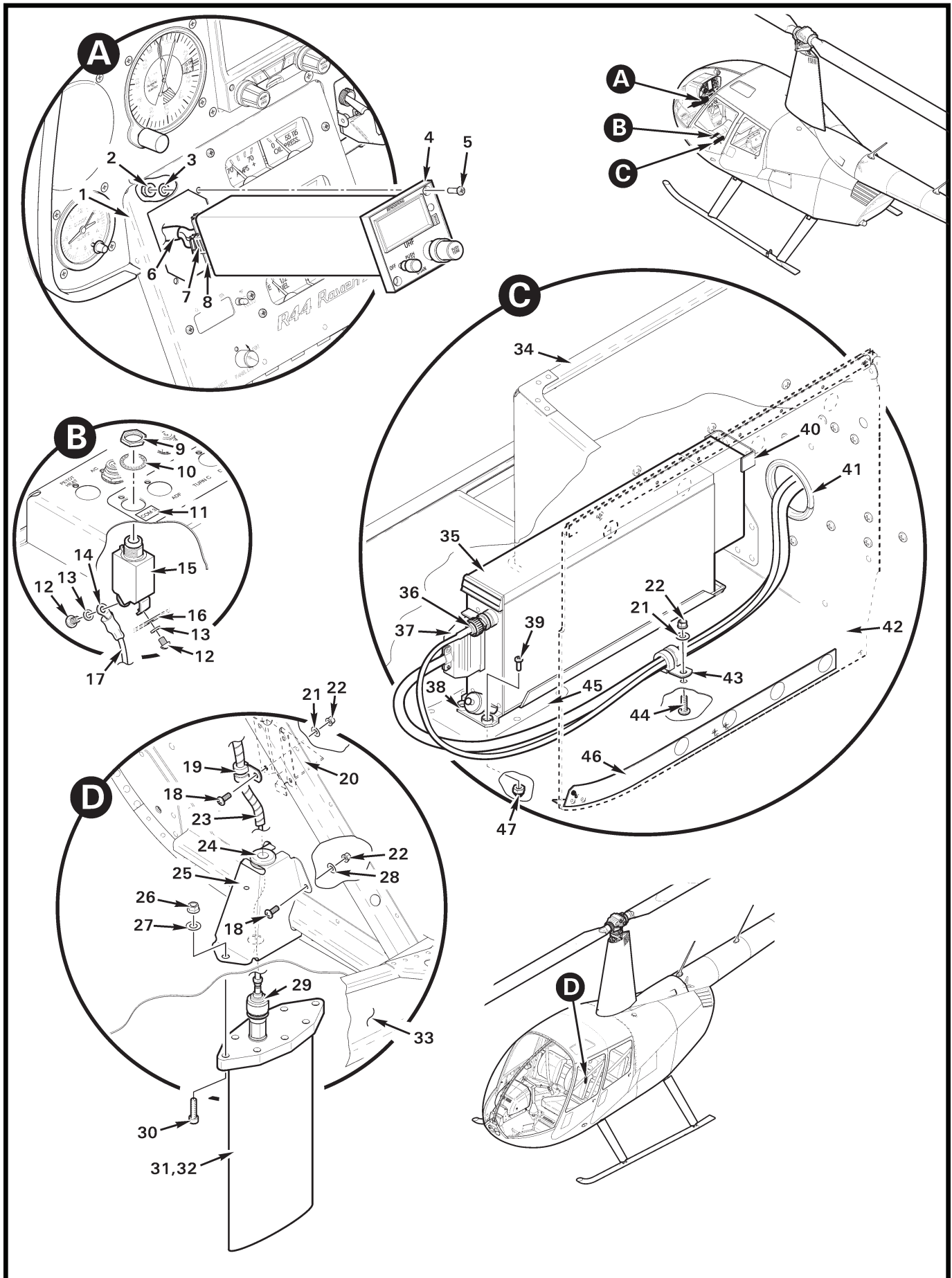

FIGURE AND INDEX NUMBER	PART NUMBER	DESCRIPTION	PARTS AVAIL	QTY PER ASSY
		C807-1 KING KTR 909 UHF TRANSCEIVER INSTALLATION		
97-49-1	C903-1	Face Assembly	X	1
2	MS21042L06	Nut	X	2
3	NAS620-6L	Washer	X	2
4	071-01546-0101	Display – Bendix-King (KTR 909A)	X	1
5	—	Screw (supplied with item 4)	O	2
6	-2668 thru -2679	Wires (Ref)		
7	030-02351-0000	Housing	X	1
	030-01188-0000	Pin	X	29
8	030-01222-0000	Housing	X	1
	030-10188-0000	Pin	X	9
9	—	Nut	O	1
10	—	Lockwasher	O	1
11	F654-38	Decal – “COM 3”	X	1
12	—	Screw	O	2
13	—	Washer	O	2
14	B260-2	Terminal	X	1
15	B297-10	Circuit Breaker (10 amp; includes items 9, 10, 12, and 13) . .	X	1
16	A448	Bus Bar (Ref)		
17	-2666	Wire (Ref)		
18	MS27039C0806	Screw	X	3
19	MS21919WDG4	Clamp	X	1
20	A454-1	Support (Ref)		
21	NAS1149FN832P	Washer	X	4
22	MS21042L08	Nut	X	4
23	B161-4	Spirap	X	A/R
24	MS35489-11	Grommet	X	1
25	C903-6	Cover	X	1
26	D210-4	Nut	X	2
27	NAS1149F0432P	Washer	X	4
28	NAS1149FN816P	Washer	X	2
29	PE4477	Plug	X	1
	-2687	Wire (Ref)		
30	NAS1351-4-16P	Screw	X	4
31	AS-3808/ARC	Antenna (84D837-1076*; install using item 32)	X	1
32	B270-1	Adhesive	X	A/R

NOTES * R. A. Miller Industries part no.

Continues

FIGURE AND INDEX NUMBER	PART NUMBER	DESCRIPTION	PARTS AVAIL	QTY PER ASSY
C807-1 KING KTR 909 UHF TRANSCEIVER INSTALLATION (Cont'd)				
97-49-33	C291-3	Support (RH, Ref; aft seat support not shown for clarity)		
34	C290-5	Seat Support (LH, Ref; FWD seat support)		
35	067-01065-0100	Transceiver	X	1
36	030-00134-0000	Plug – TNC	X	1
	-2687	Wire (Ref)		
37	030-01176-0000	Connector	X	1
	030-01428-0005	Housing	X	1
	030-03255-0000	Connector Manifold	X	1
38	071-4022-01	Rack Assembly	X	1
39	MS35206-229	Screw	X	4
40	C903-4	Support	X	1
41	NAS557-28A	Grommet	X	1
42	C748-5	Cover (Ref)		
43	MS21919WDG_	Clamp (select appropriate size for harness)	X	1
44	AN526C832R8	Screw	X	1
45	C903-3	Doubler	X	1
46	D130-3	Angle Assembly (Ref)		
47	90507A210	Nut	X	4

NOTES

Intentionally Blank

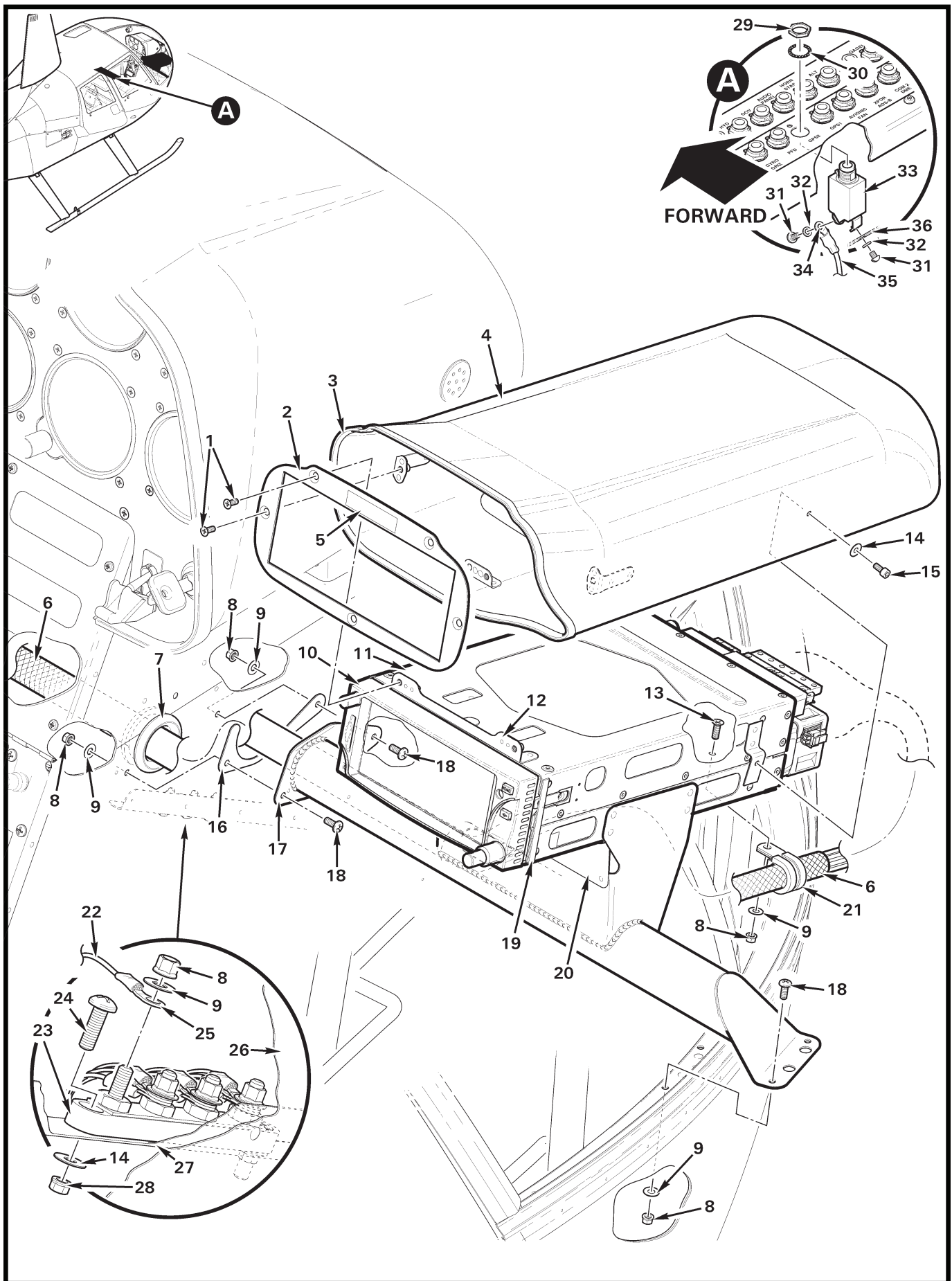

FIGURE AND INDEX NUMBER	PART NUMBER	DESCRIPTION	PARTS AVAIL	QTY PER ASSY
		C831 GPS INSTALLATION – GARMIN GTN 600 SERIES		
97-53-1	MS24694-S4	Screw	X	5
2	G704-5	Faceplate	X	1
3	A226-11	Trim	X	A/R
4	G704-1	Shell Assembly (Incl item 3)	X	1
5	F654-40	Decal (trim as required)	X	1
6	B266-8	Sleeving	X	A/R
7	NAS557-18B	Grommet	X	1
8	MS21042L08	Nut	X	6
9	NAS1149FN816P	Washer	X	5
10	GTN 650*	Transceiver (GPS/NAV/COM)	X	1
	GTN 635*	Transceiver (GPS/COM, not shown)	X	1
	GTN 625*	Transceiver (GPS, not shown)	X	1
11	—	Radio Rack Assembly (Ref, supplied with receiver or transceiver)	O	1
12	G704-7	Angle Assembly (Ref)		
13	MS24694-S4	Screw	X	1
14	NAS1149FN616P	Washer	X	3
15	92196A145	Screw	X	2
16	D703-11	Shim (3 maximum)	X	A/R
17	D703-10	Support Weldment	X	1
18	MS27039C0806	Screw	X	4
19	A226-7	Seal	X	A/R
20	G704-9	Support	X	1
21	MS21919WDG16	Clamp	X	1
22	-1427	Wire (Ref)		
23	C448	Terminal Block Assembly (Includes A448 bus bar, B562-43 screw, and B301-8 nut.)	X	1
24	MS35206-228	Screw	X	1
25	B260-3	Terminal (Ref)		
26	C359-2	Panel – Console (Ref, RH)		
27	C365-1	Angle (Ref)		
28	MS21042L06	Nut	X	1
29	—	Nut	X	1
30	—	Lockwasher	X	1
31	—	Screw	O	2

NOTES * Garmin part no.

Continues

FIGURE AND INDEX NUMBER	PART NUMBER	DESCRIPTION	PARTS AVAIL	QTY PER ASSY
		C831 GPS INSTALLATION – GARMIN GTN 600 SERIES (Cont'd)		
97-53-32	—	Washer	O	2
33	B297-5	Circuit Breaker (5 amp, 28-volt ships; includes items 33 thru 36. GPS only.)	X	1
	B297-5	Circuit Breaker (5 amp, 28-volt ships; includes items 33 thru 36. For GPS with COM or COM/NAV.)	X	2
	B297-7	Circuit Breaker (7 amp, 14-volt ships; includes items 33 thru 36. GPS only.)	X	1
	B297-10	Circuit Breaker (10 amp, 14-volt ships; includes items 33 thru 36. For GPS with COM or COM/NAV, also install one B297-7 [see above].)	X	1
34	B260-2	Terminal (Ref)		
35	-1426	Wire (Ref)		
36	A448	Bus Bar (Ref)		

NOTES

Intentionally Blank

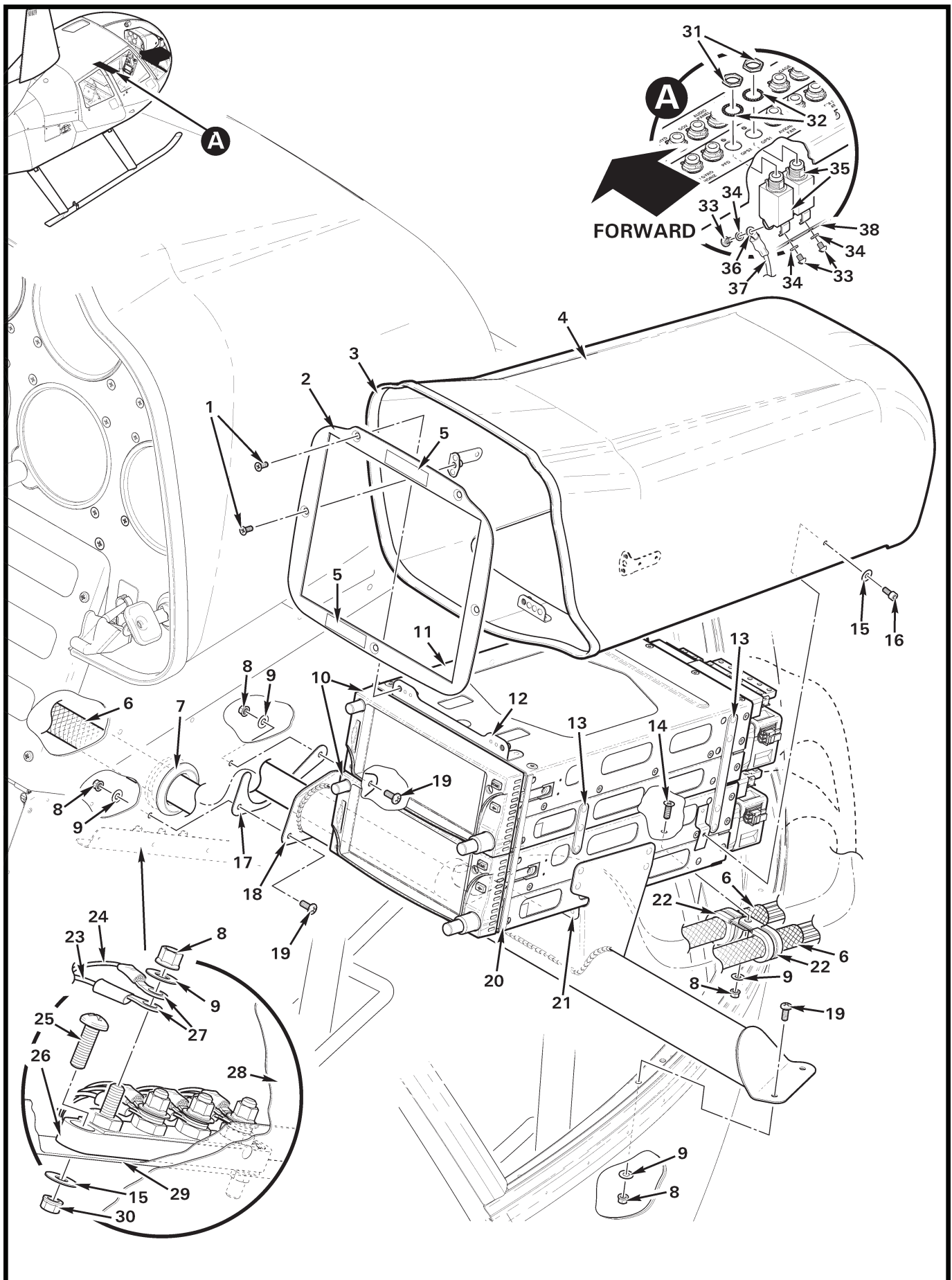

FIGURE AND INDEX NUMBER	PART NUMBER	DESCRIPTION	PARTS AVAIL	QTY PER ASSY
		C831 GPS INSTALLATION – GARMIN GTN 600 SERIES (DUAL)		
97-57-1	MS24694-S4	Screw	X	5
2	G704-13	Faceplate	X	1
3	A226-11	Trim	X	A/R
4	G704-11	Shell Assembly (Incl item 3)	X	1
5	F654-40	Decal (trim as required)	X	2
6	B266-8	Sleeving	X	A/R
7	NAS557-18B	Grommet	X	1
8	MS21042L08	Nut	X	6
9	NAS1149FN816P	Washer	X	5
10	GTN 625*	GPS Transceiver	X	A/R
	GTN 635*	GPS Transceiver	X	A/R
	GTN 650*	GPS Transceiver	X	A/R
11	—	Radio Rack Assembly (Ref, supplied with receiver or transceiver)	O	2
12	G704-7	Angle Assembly (Ref)		
13	A684-1	Strap (Ref)		
14	MS24694-S5	Screw	X	1
15	NAS1149FN616P	Washer	X	3
16	92196A145	Screw	X	2
17	D703-11	Shim (3 maximum)	X	A/R
18	D703-10	Support Weldment	X	1
19	MS27039C0806	Screw	X	4
20	A226-7	Seal	X	A/R
21	G704-9	Support	X	1
22	MS21919WDG16	Clamp	X	2
23	-465	Wire (Ref; GPS 1)		
24	-1427	Wire (Ref; GPS 2)		
25	MS35206-228	Screw	X	1
26	C448-2	Terminal Block Assembly (includes A448 bus bar, B562-43 screw, and B301-8 nut)	X	1
27	B260-3	Terminal	X	2
28	C359-2	Panel – Console (Ref)		
29	C365-1	Angle (Ref)		
30	MS21042L06	Nut	X	1
31	—	Nut	O	2

NOTES * Garmin part no.

Continues

FIGURE AND INDEX NUMBER	PART NUMBER	DESCRIPTION	PARTS AVAIL	QTY PER ASSY
C831 GPS INSTALLATION – GARMIN GTN 600 SERIES (DUAL; Cont'd)				
97-57-32	—	Lockwasher	O	2
33	—	Screw	O	4
34	—	Washer	O	4
35	B297-5	Circuit Breaker (5 amp; includes items 31 thru 34)	X	2
	B297-7	Circuit Breaker (7 amp; for R44s when GTN 635 or 650 is installed; includes items 31 thru 34)	X	2
	B297-10	Circuit Breaker (10 amp; for R44s when GTN 625 is installed; includes items 31 thru 34)	X	2
36	B260-2	Terminal (Ref)		
37	-466	Wire (Ref; GPS 1)		
	-1426	Wire (Ref; GPS 2)		
38	A448	Bus Bar (Ref)		

NOTES

Intentionally Blank

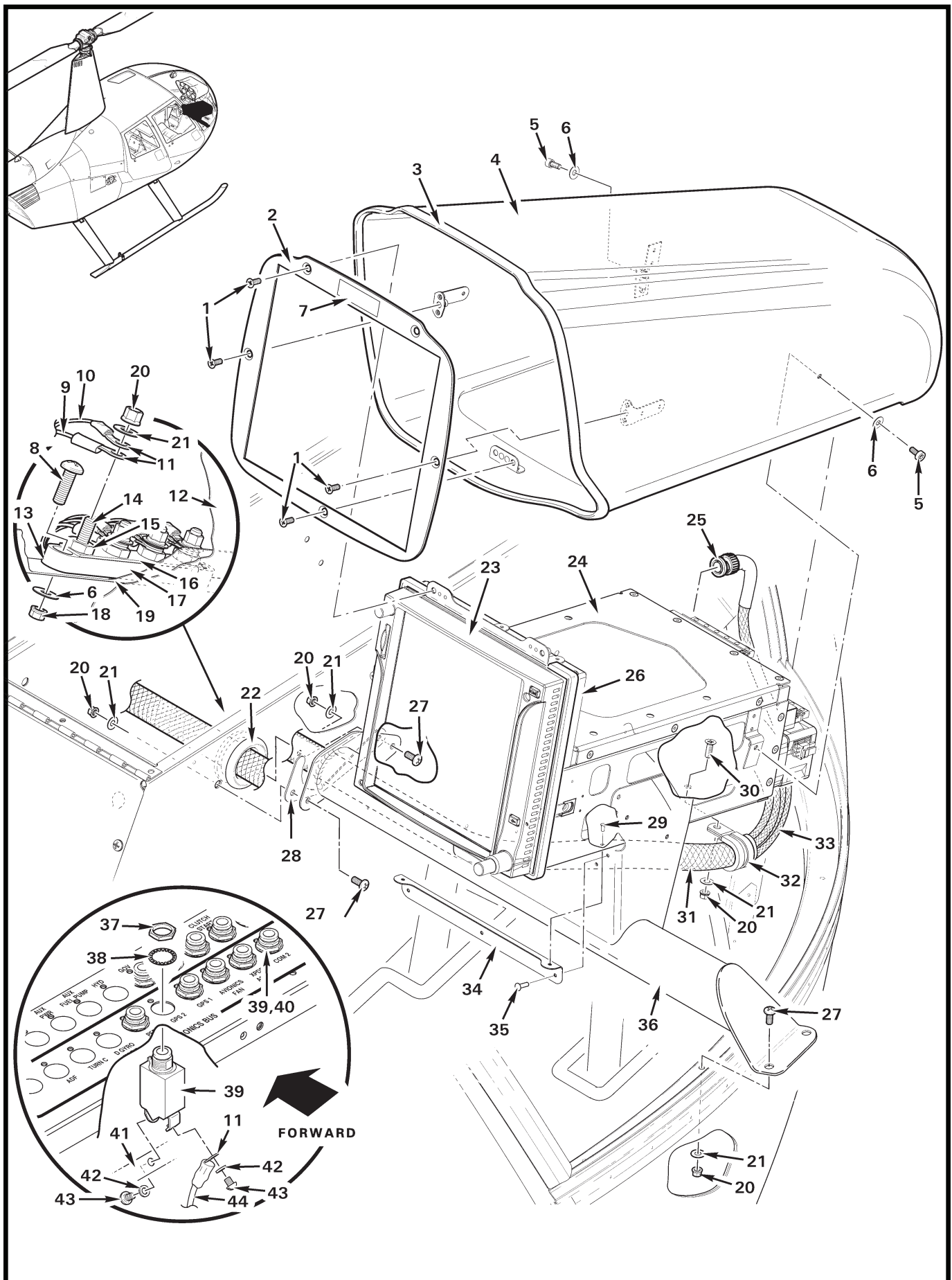

FIGURE AND INDEX NUMBER	PART NUMBER	DESCRIPTION	PARTS AVAIL	QTY PER ASSY
		C831 GPS INSTALLATION – GARMIN GTN 700 SERIES		
97-61-1	MS24693-S26	Screw	X	4
2	G704-6	Faceplate	X	1
3	A226-11	Trim	X	A/R
4	G704-2	Shell Assembly (Incl item 3)	X	1
5	92196A145	Screw	X	2
6	NAS1149FN616P	Washer	X	3
7	F654-40	Decal "No. 1, No. 2, No. 3, GPS/NAV/COM"	X	A/R
8	MS35206-228	Screw	X	2
9	C831-201/-704	Wire – Ground (-201 [COM 1], -704 [COM 2]; Ref)		
10	C831-465/-1427	Wire – Ground (-465 [GPS 1], -1427 [GPS 2]; Ref)		
11	B260-3	Terminal	X	A/R
12	C033	Console Assembly – Lower (Ref)		
13	C448-2	Terminal Block Assembly (Incl items 14 thru 17)	X	1
14	B567-43	Screw	X	4
15	B301-8	Nut	X	4
16	A448-10	Bus Bar (4-hole)	X	1
17	C448-5	Block	X	1
18	MS21042L06	Nut	X	A/R
19	C365-1	Angle (Ref)		
20	MS21042L08	Nut	X	4
21	NAS1149FN816P	Washer	X	4
22	NAS557-18B	Grommet	X	1
23	GTN 750*	Transceiver (GPS/NAV/COM)	X	1
	GTN 725*	Transceiver (GPS, not shown)	X	1
24	—	Rack (Ref)		
25	5225395-6	Plug (antenna cable)	X	1
26	A226-7	Seal	X	A/R
27	MS27039C0806	Screw	X	4
28	D703-11	Shim	X	A/R
29	MS20426AD3	Rivet	X	2
30	MS24694-4	Screw	X	1
31	B266-8	Sleeving	X	A/R
32	MS21919WDG16	Clamp	X	1
33	B266-4	Sleeving	X	A/R
34	G704-10	Support	X	1

NOTES * Garmin part no.

Continues

FIGURE AND INDEX NUMBER	PART NUMBER	DESCRIPTION	PARTS AVAIL	QTY PER ASSY
C831 GPS INSTALLATION – GARMIN GTN 700 SERIES (Cont'd)				
97-61-35	MS20470AD3	Rivet	X	2
36	D703-10	Support Weldment	X	1
37	—	Nut	O	1
38	—	Lockwasher	O	1
39	B297-5	Circuit Breaker (5 amp, 28-volt ships; includes items 37, 38, 42, and 43. GPS only, or GPS with COM, or GPS with COM/NAV.)	X	1
	B297-7	Circuit Breaker (7 amp, 14-volt ships; includes items 37, 38, 42, and 43. GPS only.)	X	1
	B297-10	Circuit Breaker (10 amp, 14-volt ships; includes items 37, 38, 42, and 43. For GPS with COM or COM/NAV, also install one B297-7 [see above].)	X	1
40	C859-200 or -703	Wire (-200 [COM 1], -703 [COM 2], not shown; Ref)		
41	A448	Bus Bar (Ref)		
42	—	Washer	O	2
43	—	Screw	O	2
44	C859-466 or -1426	Wire (Ref; -466 [GPS 1], -1426 [GPS 2])		

NOTES

CHAPTER 99
SPECIAL TOOLS

<i>Figure</i>	<i>Title</i>	<i>Page</i>
99-1	Field Kits	99.1
99-3	R44 Technical Publications	99.3
99-5	Special Tools	99.4
99-7	Special Tools	99.6
99-9	Special Tools	99.8
99-11	Special Tools	99.10
99-13	Pop-Out Float Cylinder Assembly Tools	99.12
99-15	Shipping Crates	99.14
99-17	Shipping Crates	99.16

Intentionally Blank

FIGURE AND INDEX NUMBER	PART NUMBER	DESCRIPTION	PARTS AVAIL	QTY PER ASSY
FIELD KITS*				
99-1-1	R7983	R44-series C017-5 Swashplate Installation Field Kit		
2	KI-4401	R44-series Minimum Spare Parts Kit Instructions		
3	KI-4402	R44 (Raven I & Clipper I) 2200-Hour Inspection Kit Instructions		
4	KI-4403	R44 II (Raven II & Clipper II) 2200-Hour Inspection Kit Instructions		
5	KI-4405	R44 O-540 Engine Installation Provisions Kit & Instructions		
6	KI-4406	R44 II IO-540 Engine Installation Provisions Kit & Instructions		
7	KI-4407-1	R44-series Interior Furnishings Installation Kit Instructions (Velour)		
8	KI-4407-2	R44-series Interior Furnishings Installation Kit Instructions (Leather)		

NOTES * See www.robinsonheli.com for the latest kit contents.

Intentionally Blank

FIGURE AND INDEX NUMBER	PART NUMBER	DESCRIPTION	PARTS AVAIL	QTY PER ASSY
R44 TECHNICAL PUBLICATIONS				
99-3-1	R7204	R44 Maintenance Manual (Incl items 2 thru 4)	X	1
2	R7205	R44 Maintenance Manual — Binder	X	1
3	R7211	R44 Maintenance Manual — Tabs	X	1
4	R7207	R44 Maintenance Manual — Inserts	O	1
* * *				
5	R7281	R44 Illustrated Parts Catalog (Incl items 6 thru 8)	X	1
6	R7216	R44 Illustrated Parts Catalog — Binder	X	1
7	R7214	R44 Illustrated Parts Catalog — Tabs	X	1
8	R7215	R44 Illustrated Parts Catalog — Insert	O	1
* * *				
9	R8656	Maintenance Record — Binder	X	1
10	R8650	Maintenance Record — Tabs	X	1
11	R8478	Maintenance Record — Insert (Incl item 12)	X	1
12	R8479	Maintenance Record — Component Cards (pack of 20)	X	1
* * *				
13	R7282	R44 POH (Incl items 14 thru 16)	X	1
14	R7219	R44 POH — Binder	X	1
15	R7226	R44 POH — Tabs	X	1
16	R7218	R44 POH — Insert	O	1
* * *				
17	R8188	R44 II POH (Incl items 18 thru 20)	X	1
18	R8189	R44 II POH — Binder	X	1
19	R7226	R44 II POH — Tabs	X	1
20	R8190	R44 II POH — Insert	O	1
* * *				
21	R8670	R44 Cadet POH (Incl items 22 thru 24)	X	1
22	R8671	R44 Cadet POH — Binder	X	1
23	R7226	R44 Cadet POH — Tabs	X	1
24	R8672	R44 Cadet POH — Insert	O	1
NOTES				

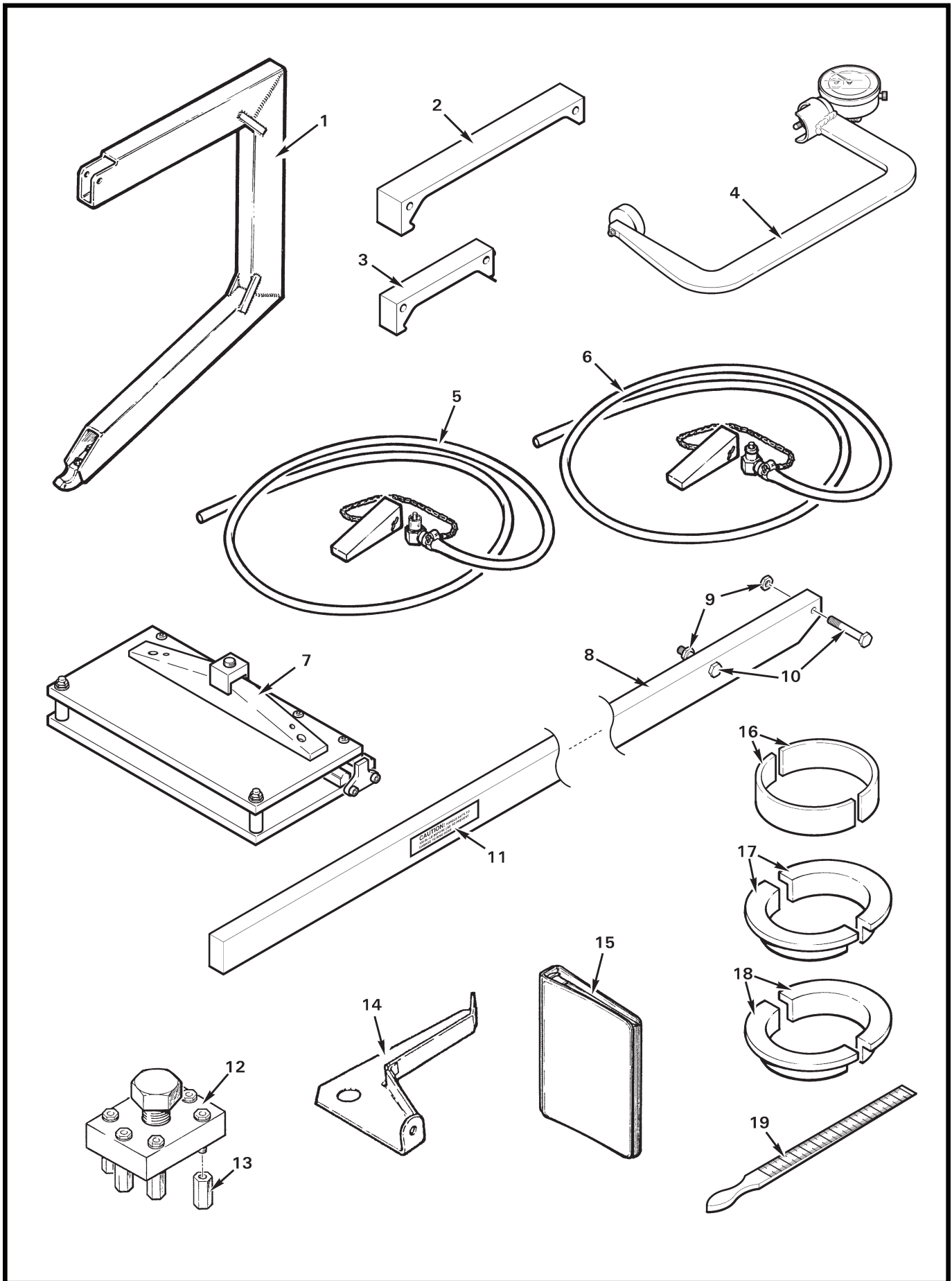

FIGURE AND INDEX NUMBER	PART NUMBER	DESCRIPTION	PARTS AVAIL	QTY PER ASSY
SPECIAL TOOLS				
99-5-1	MT548-1	Engine Hoist Adapter (includes fitting, bolt, washers and nuts)	X	1
	MT548-7	Fitting	X	1
	NAS6604-17	Bolt	X	2
	NAS1149F0432P	Washer ([1] under head, [1] under nut)	X	4
	D210-4	Nut (or MS21042L4)	X	2
2	MT525-1	Main Rotor Rigging Fixture	X	1
3	MT525-2	Tail Rotor Rigging Fixture (includes clip and [2] screws)	X	1
	MT050-8	Clip	X	1
	91251A144	Screw	X	2
4	MT122-6	Main Rotor Hub Bolt Stretch Measuring Tool (includes MT200-1 indicator and attaching hardware)	X	1
	MT200-1	Indicator	X	1
	MS27039C0809	Screw	X	1
	NAS1149FN832P	Washer	X	1
	MS21042L08	Nut	X	1
5	MT053-1	Main Rotor Gearbox Drain Valve Tool (use only with old-style A7260* chip detector)	X	1
6	MT054-1	Main Rotor Gearbox Drain Valve Tool (use only with B566-1 "quick release" chip detector)	X	1
7	MT526-1	Main Rotor Blade Trim Tab Bender (C016-2 AND C016-5 STAINLESS STEEL BLADES ONLY)	X	1
	MT526-8	Main Rotor Blade Trim Tab Bender (C016-7 ALUMINUM BLADES ONLY)	X	1
8	MT091-1	Engine Ring Gear Holder Assembly (Incl items 9 thru 11)	X	1
9	AN316-4	Nut	O	2
10	NAS6604-19	Bolt	X	2
11	MT091-3	Decal ("Caution: Torque nuts to 100 in-LB...")	X	1
12	MT592-1	Fan Puller (Incl item 13 and [6] NAS6605-16 bolts)	X	1
13	MT092-3	Spacer (Rev. H, 1.200-inches long)	X	6
14	MT121-1	Bracket Assembly – Magnetic Pickup	X	1
15	60297-10	O-540 & IO-540 Engine Operator's Manual (Lycoming part no.; available online at www.lycoming.com)	O	1
16	MT146-4	Blocks – Lower Swashplate Rigging (Set of [2]; use with F198-1 swashplate.)	X	1
17	MT146-3	Blocks – Lower Swashplate Rigging (Set of [2]; use with C198-2 swashplate.)	X	1
18	MT146-2	Blocks – Lower Swashplate Rigging (Set of [2]; use with C198-1 swashplate.)	X	1
19	MT357-9	Taper Gage	X	1
<p>NOTES * No longer available.</p>				

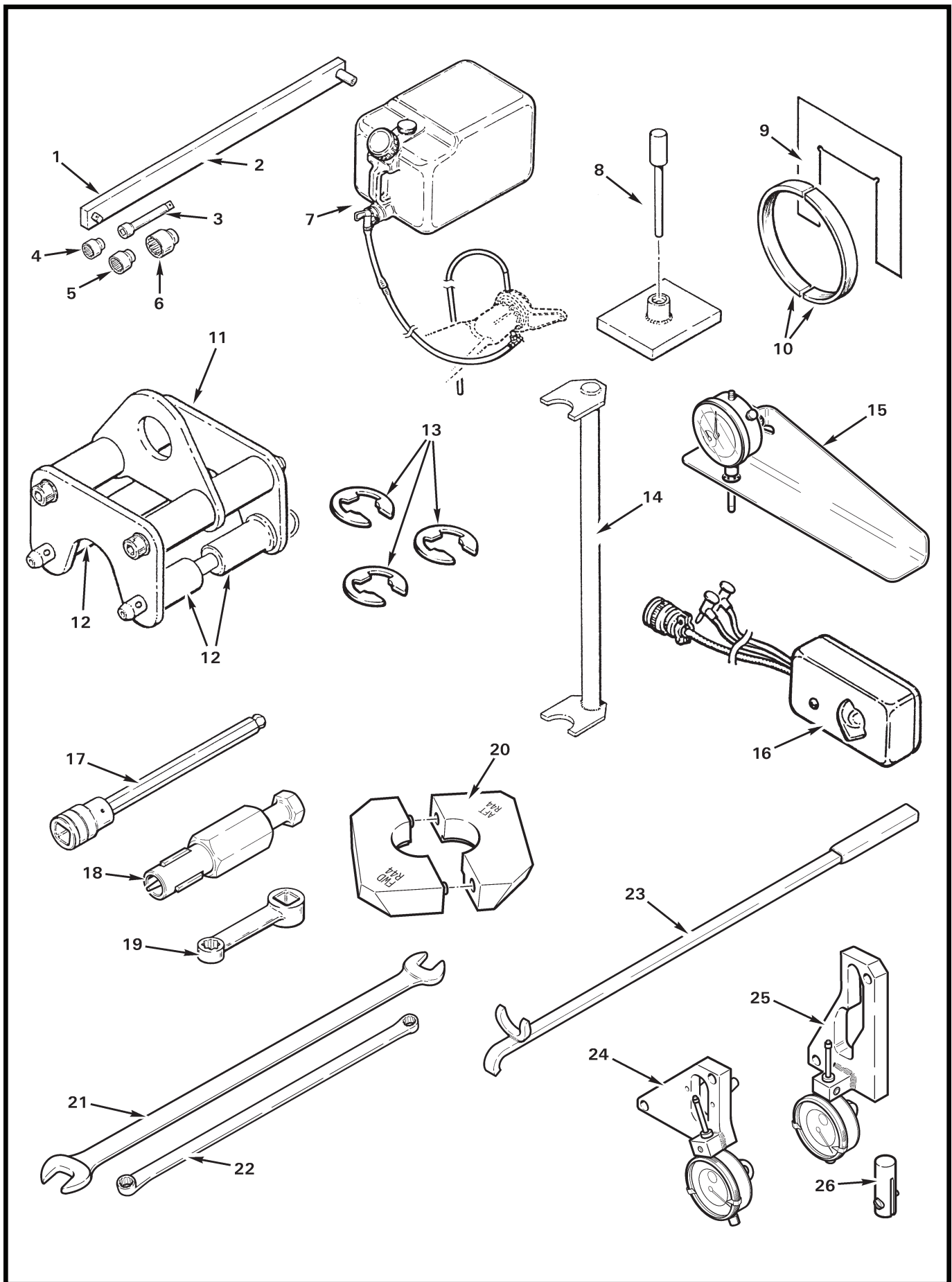

FIGURE AND INDEX NUMBER	PART NUMBER	DESCRIPTION	PARTS AVAIL	QTY PER ASSY
SPECIAL TOOLS				
99-7-1	MT173-5	Torque Wrench Extension Tool Set – Fan Nut (R22 and R44; includes items 2 thru 6; no longer available)	O	1
2	MT173-6	Torque Wrench Welded Assembly (no longer available)	O	1
3	MT173-9	Extension Bar (3/4" drive, 8" length)	X	1
4	MT173-7	Socket (3/4" drive, 1-1/2" 12 pt)	X	1
5	MT173-4	Socket (3/4" drive, 1-11/16" 12 pt)	X	1
6	MT173-8	Socket (3/4" drive, 2" 12 pt)	X	1
7	MT147-1	Air Bleed Tool Assembly – Main Rotor Spindle	X	1
8	MT252-1	Bearing Pressing Tool – Tail Rotor Hub	X	1
9	MT549-2	Flat Plate	X	1
10	MT549-1	Spacer – Spindle Boot Adjustment	X	2
11	MT527-1	Helicopter Lifting Fixture (Incl item 12)	X	1
12	MT527-5	Bushing (nylon; type 6/6)	X	4
13	MS16633-2018	Retaining Ring ([3] required for removal or installation of collective spring assembly. Not for in-flight use. See also Figure 67-25.)	X	3
14	MT544-2	Spring Retainer – Trim	X	1
15	MT352-1	Main Rotor Blade Trim Tab Gage (includes MT200-1 dial indicator)	X	1
	MT200-1	Dial Indicator (dial indicator only)	X	1
16	MT547-1	Cyclic Trim Set-Up Box (no longer available)	O	1
17	MT357-4	Hex Driver (FABL8*; 3/8" square drive)	X	1
18	MT357-8	Nipple Chuck	X	1
19	MT357-5	Torque Adapter (FRDH101*; 3/8" square drive)	X	1
20	MT559-1	Blocks – Main Rotor Rigging (set; holds cyclic in neutral position)	X	1
21	MT357-6	Wrench – Open End (3/8" & 7/16"; LTA1214*)	X	1
22	MT357-7	Wrench – Box End (7/32" & 1/4"; XDH78A*)	X	1
23	MT516-1	Valve Spring Compressor Tool	X	1
24	MT133-5	Engine Valve Clearance Check Tool (angle valve)	X	1
25	MT133-1	Engine Valve Clearance Check Tool (parallel valve)	X	1
26	MT133-9	Adapter Assembly (used with items 24 and 25)	X	1

NOTES * Snap-On part no.

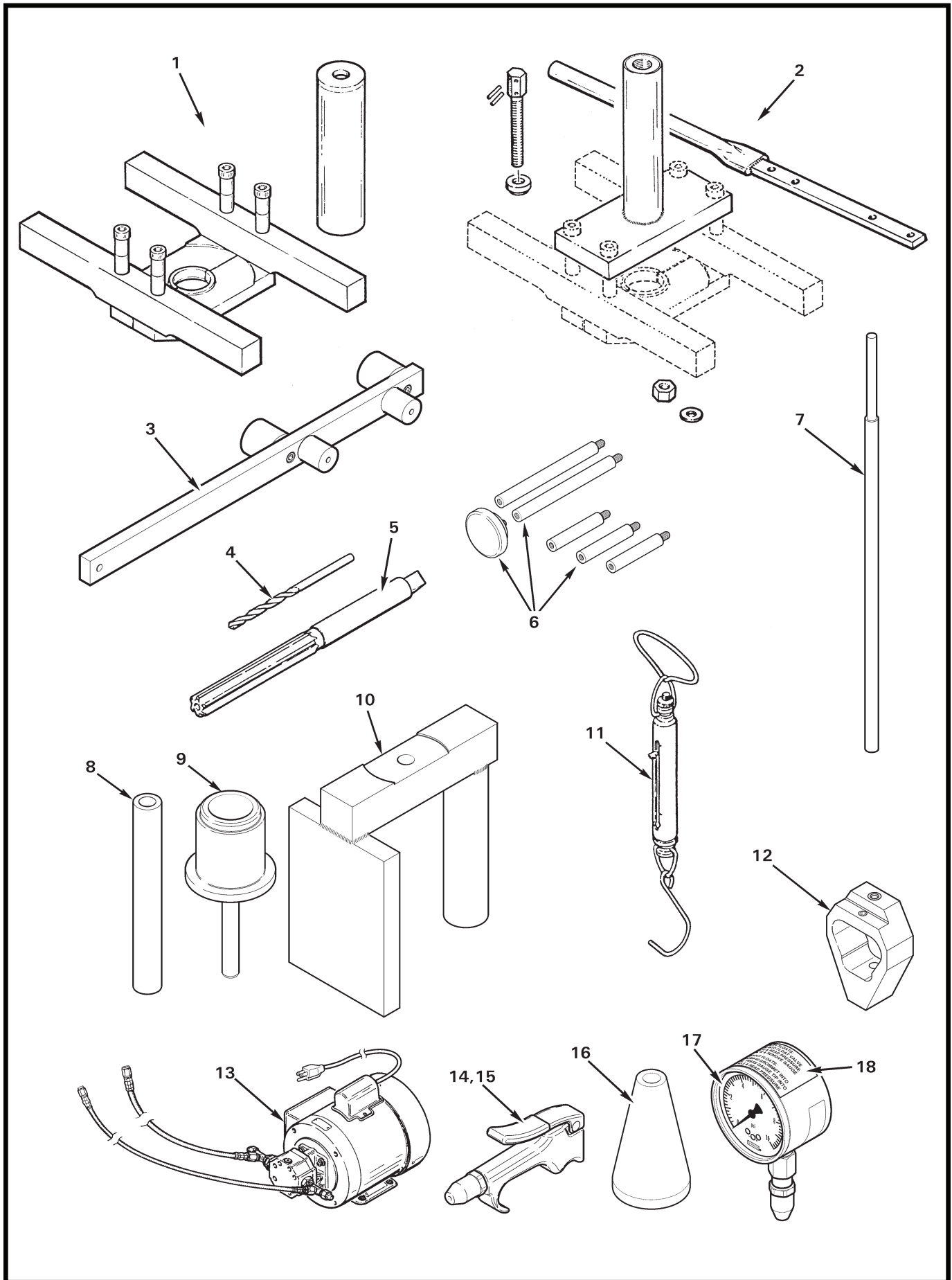

FIGURE AND INDEX NUMBER	PART NUMBER	DESCRIPTION	PARTS AVAIL	QTY PER ASSY
SPECIAL TOOLS				
99-9-1	MT528-1	Clutch Bearing (C184) Removal/Installation Tool (For use with hydraulic press.)	X	1
2	MT528-2	Clutch Bearing (C184) Removal/Installation Tool (For use when hydraulic press is not available; order also item 1.)	X	1
3	MT354-7	Teeter Moment Tool	X	1
4	MT357-3	Drill Bit (steel, cobalt; 0.156 in. dia.)	X	1
5	MT357-2	Reamer (0.375 in. dia.)	X	1
6	MT260-6	Tail Rotor Drive Shaft Runout Indicator Kit	X	1
	MT260-5	Foot	X	1
	MT260-2	Extension (1.00 inch long)	X	3
	MT260-3	Extension (2.00 inches long)	X	2
7	MT331-4	Sheave Alignment Bar	X	1
8	MT329-10	Tube – Press Extension (used with items 9 and 10)	X	1
9	MT329-6	Plug (MR hub bearing installation)	X	1
10	MT643-1	Support (MR hub bearing installation)	X	1
11	MT359-1	Spring Scale	X	1
12	MT569-2	Guide Assembly – Drill (main rotor hub nut)	X	1
13	MT384-1	Hydraulic Test Pump (U.S. / Canada / Mexico – 110 V)	X	1
	MT384-2	Hydraulic Test Pump (Outside North America – 220 V)	X	1
14	MT340-1	Float Gage and Fill Gun Kit (Incl items 15, 17, and [2] MS35489-40 grommets; not shown)	X	1
15	MT340-2	Airgun Assembly	X	1
16	MT401-1	Topping Valve Adapter	X	1
17	MT340-3	Gage Assembly (Incl item 18)	X	1
18	MT340-4	Decal (air pressure gage instructions)	X	1

NOTES

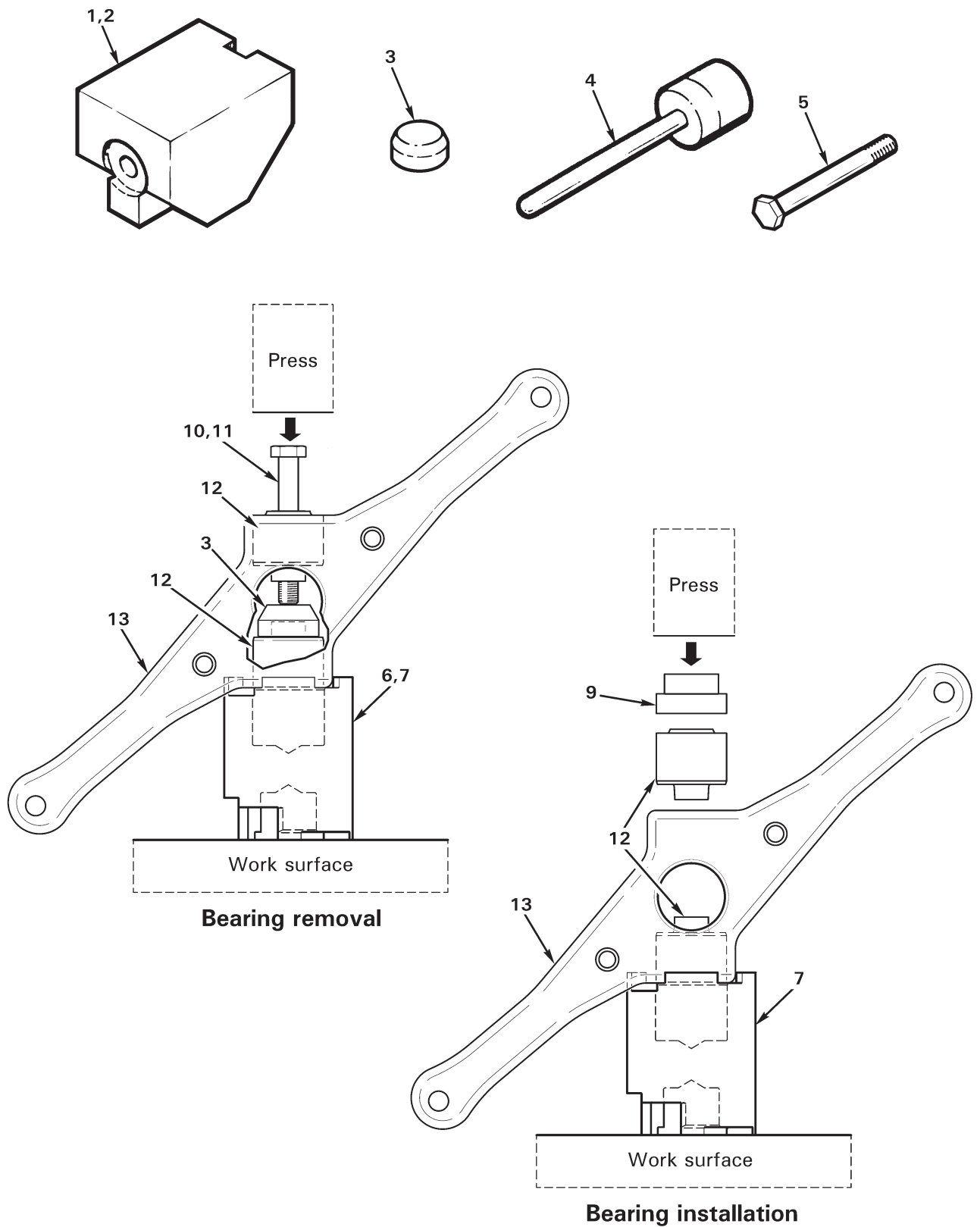

FIGURE AND INDEX NUMBER	PART NUMBER	DESCRIPTION	PARTS AVAIL	QTY PER ASSY
SPECIAL TOOLS				
99-11-1	MT556-11	Kit – Tail Rotor Elastomeric Bearing Removal and Installation Tools (Incl items 2 thru 5; no longer available.)	O	1
2	MT556-15	Support	O	1
3	MT556-16	Cap (R44 and R66)	X	1
4	MT556-12	Mandrel Assembly	O	1
5	AN6-34A	Bolt	X	1
6	MT556-17	Kit – Tail Rotor Elastomeric Bearing Removal and Installation Tools (Incl items 3, 7 thru 11)	X	1
7	MT556-18	Support	X	1
8	MT556-6	Cap (R22; not shown)	X	1
9	MT556-19	Driver	X	1
10	NAS6604-26	Bolt	X	1
11	NAS6604-36	Bolt	X	1
12	B361-2	Bearing (Ref; see Figure 64-5)		
13	D062-2	Tail Rotor Hub (Ref; see Figure 64-5)		
NOTES				

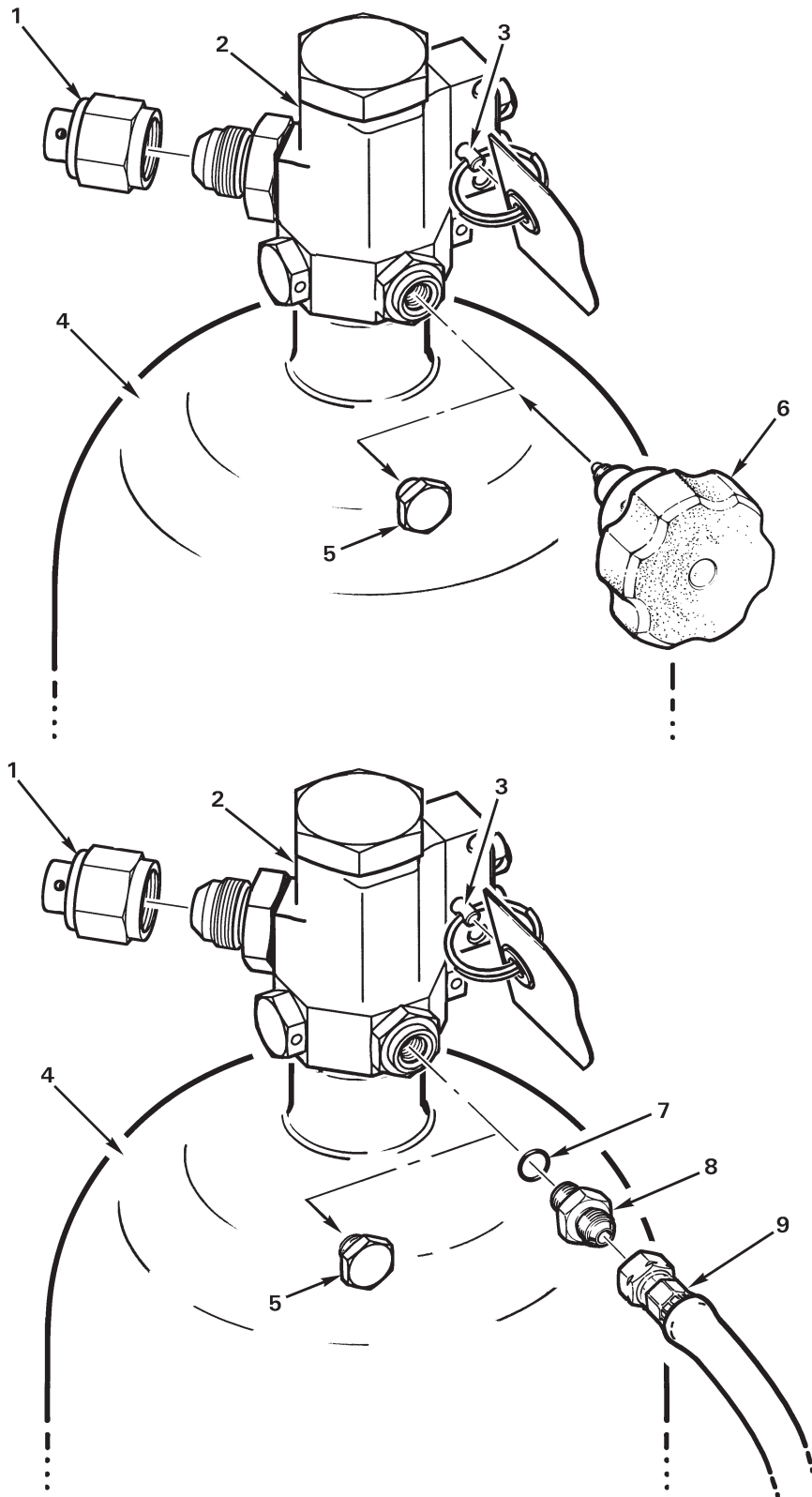

FIGURE AND INDEX NUMBER	PART NUMBER	DESCRIPTION	PARTS AVAIL	QTY PER ASSY
POP-OUT FLOAT CYLINDER ASSEMBLY TOOLS*				
99-13-1	MT546-1	Diffuser	X	1
2	D757-1 * *	Valve Assembly	O	1
3	MT545-1	Pin Assembly (Ref; see Figure 32-13)		
4	D679-3	Cylinder Assembly (Ref; see Figure 32-13)		
5	D767-7	Fill-port cap (Ref)		
6	MT546-6	Bleed Fitting Assembly	X	1
7	MS28778-2	Packing (o-ring)	X	1
8	MT546-2	Adapter Assembly (Incl item 7)	X	1
9	—	Fill Hose (Ref)		
10	KI-151	Cylinder Bleed-off Kit (Incl items 1, 3, 6 thru 8)	X	1

NOTES * Refer to R44 Service Bulletin SB-80.
 ** Order KI-211 to replace.

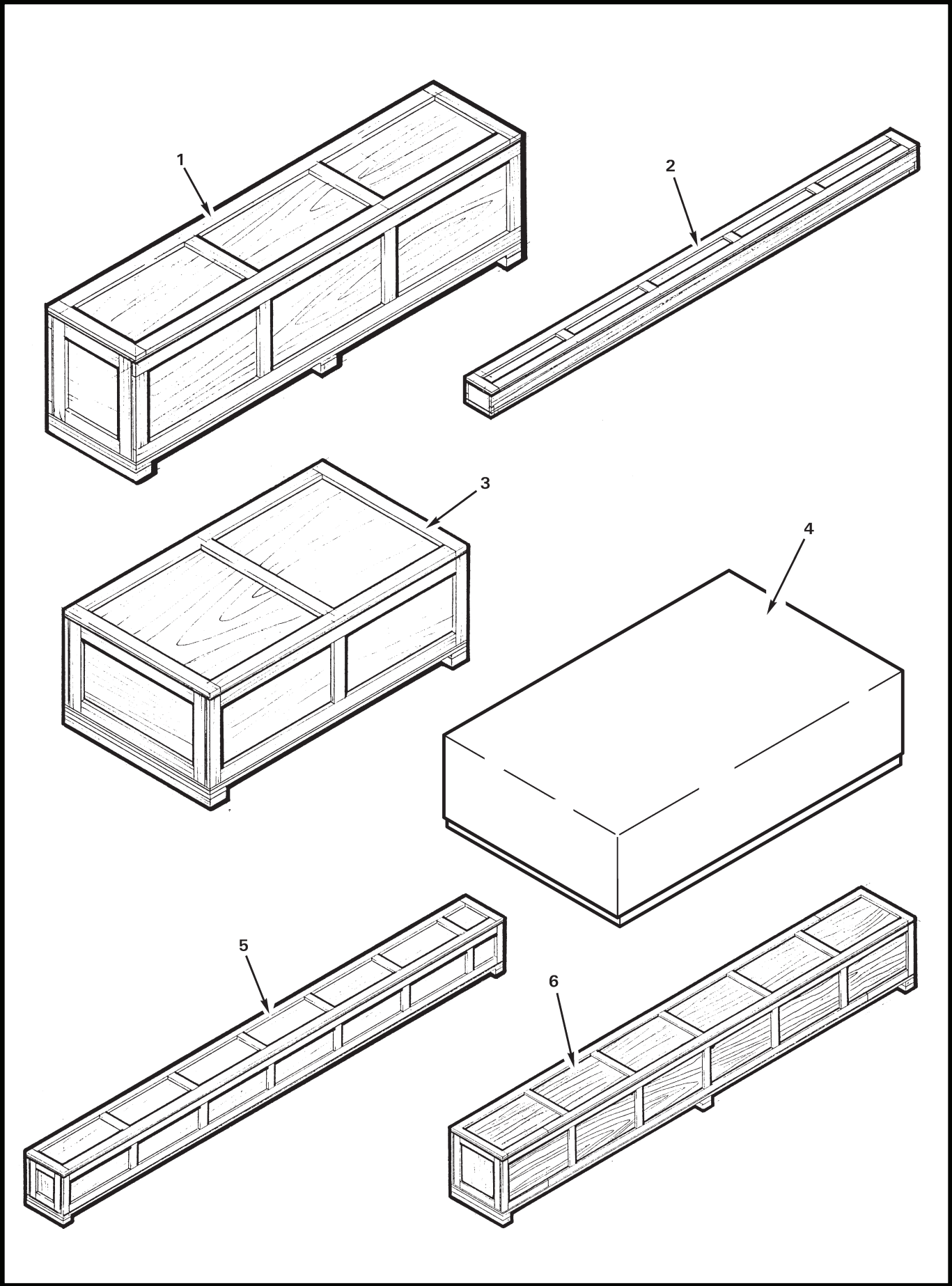

FIGURE AND INDEX NUMBER	PART NUMBER	DESCRIPTION	PARTS AVAIL	QTY PER ASSY
SHIPPING CRATES*				
99-15-1	R5384	Main Rotor Gearbox Crate (90" X 24" X 27", 265 lbs)	X	1
2	R5385	Push-Pull Tube/Tail Rotor Drive Shaft Crate (192" X 11" X 16", 165 lbs; holds [4] push/pull tubes or [4] TR driveshafts)	X	1
3	R5386	Cabin Door Crate (60" X 34" X 23"; 25 lbs; holds [1] bubble or [2] regular doors)	X	1
4	R5170	Windshield Box (63" X 40" X 17"; 45 lbs; cardboard. Holds up to [3] windshields.)	X	1
5	R5352	Main Rotor Blade Crate (207" X 17" X 21"; 390 lbs)	X	1
6	R5388	Tailcone Crate (194" X 24" X 28"; 290 lbs)	X	1

NOTES * Dimensions are approximate and expressed in inches. Dimensions given describe length, width, and height. Weight stated is approximate and includes crate and contents.

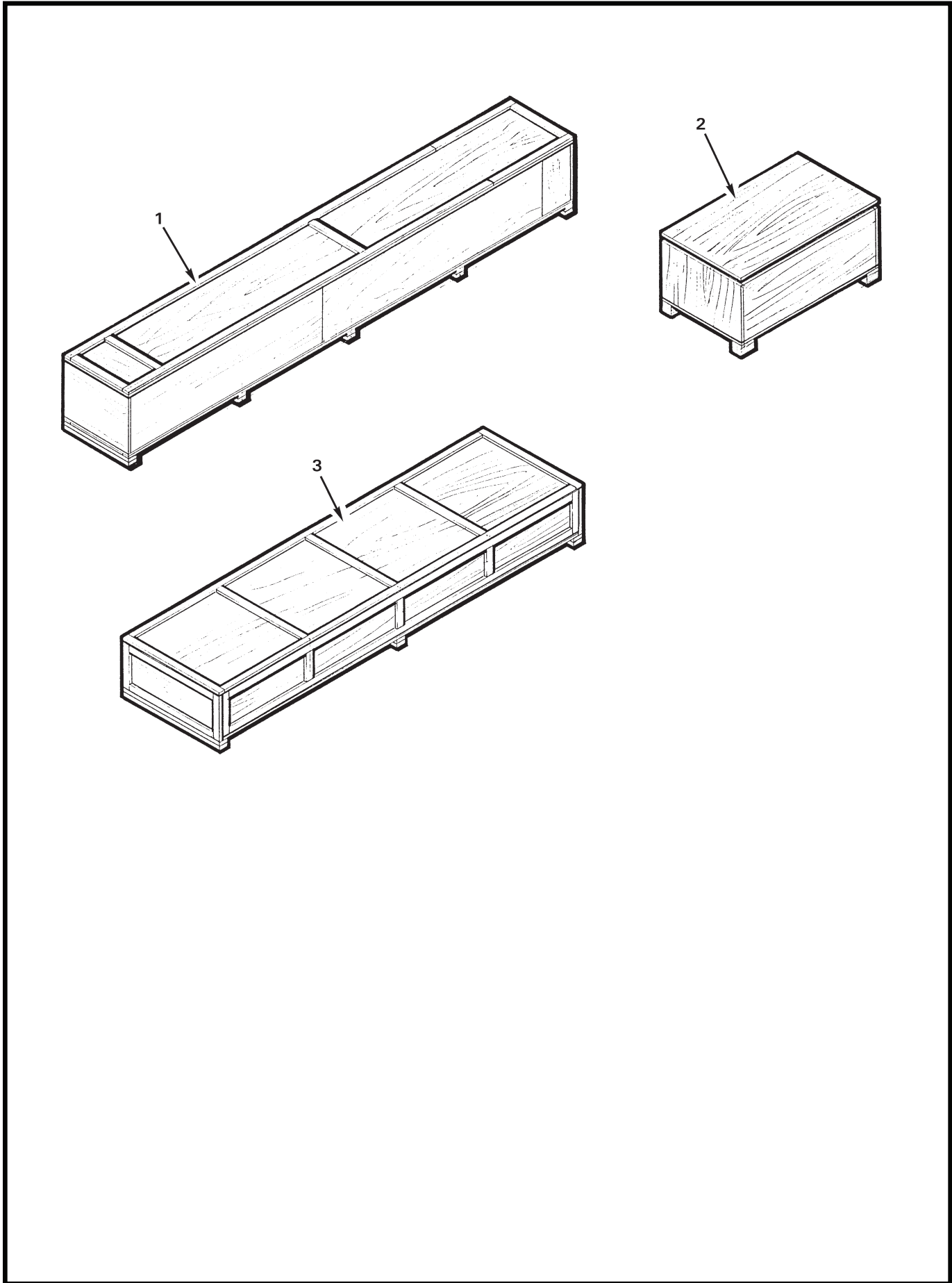

FIGURE AND INDEX NUMBER	PART NUMBER	DESCRIPTION	PARTS AVAIL	QTY PER ASSY
SHIPPING CRATES*				
99-17-1	R5702	Main Rotor Blade [2] / Tailcone [1] Crate (208" X 30" X 29"; 695 lbs)	X	1
2	MT899-1	Tow Cart Crate (67" X 38" X 31"; 572 lb)	X	1
3	R7423	Float Crate (172" X 45" X 22"; 485 lb)	X	1

NOTES * Dimensions are approximate and expressed in inches. Dimensions given describe length, width, and height. Weight stated is approximate and includes crate and contents.

Intentionally Blank

CHAPTER 100

REVISION LOG

<i>Figure</i>	<i>Title</i>	<i>Page</i>
—	Revision Log	100.0

Intentionally Blank

REVISION LOG

FEB 2024

The R44 Illustrated Parts Catalog (IPC) list of effective pages and effective dates are given below. If a previously issued page is not listed below, it is no longer an effective page and must be discarded. The issue or revision date is in bold at the top of each revision log page.

Please visit <https://robinsonheli.com> to verify the issue or revision date is current.

<u>Page</u>	<u>Date</u>	<u>Page</u>	<u>Date</u>	<u>Page</u>	<u>Date</u>
i	FEB 2024	6.7	JAN 2014	6.38	APR 2016
ii	FEB 2024	6.8	JAN 2014		
iii	DEC 2021	6.9	JAN 2014	8.i	FEB 2024
iv	DEC 2021	6.10	JAN 2014	8.0	FEB 2024
v	DEC 2021	6.11	JAN 2014	8.1	FEB 2024
vi	DEC 2021	6.12	JAN 2014	8.2	FEB 2024
vii	DEC 2021	6.13	FEB 2020	8.3	FEB 2024
viii	DEC 2021	6.14	FEB 2020	8.4	FEB 2024
ix	DEC 2021	6.15	APR 2016		
x	DEC 2021	6.16	APR 2016	9.i	JAN 2014
xi	DEC 2021	6.17	APR 2016	9.0	JAN 2014
xii	DEC 2021	6.18	APR 2016	9.1	FEB 2020
xiii	DEC 2021	6.19	FEB 2020	9.2	FEB 2020
xiv	DEC 2021	6.20	FEB 2020	9.3	JAN 2014
xv	DEC 2021	6.21	JAN 2014	9.4	JAN 2014
xvi	DEC 2021	6.22	JAN 2014	9.5	JAN 2014
xvii	DEC 2021	6.23	JAN 2014	9.6	JAN 2014
xviii	DEC 2021	6.24	JAN 2014	9.7	JAN 2014
xix	DEC 2021	6.25	JAN 2014	9.8	JAN 2014
xx	DEC 2021	6.26	JAN 2014	9.9	JAN 2014
xxi	DEC 2021	6.27	FEB 2020	9.10	JAN 2014
xxii	DEC 2021	6.28	FEB 2020	9.11	JAN 2014
		6.29	APR 2016	9.12	JAN 2014
6.i	APR 2016	6.30	APR 2016		
6.0	APR 2016	6.31	APR 2016	10.i	JAN 2014
6.1	JAN 2014	6.32	APR 2016	10.0	JAN 2014
6.2	JAN 2014	6.33	APR 2016	10.1	JAN 2014
6.3	JAN 2014	6.34	APR 2016	10.2	JAN 2014
6.4	JAN 2014	6.35	APR 2016	10.3	JAN 2014
6.5	JAN 2014	6.36	APR 2016	10.4	JAN 2014
6.6	JAN 2014	6.37	APR 2016	10.5	JAN 2014

REVISION LOG

FEB 2024

<u>Page</u>	<u>Date</u>	<u>Page</u>	<u>Date</u>	<u>Page</u>	<u>Date</u>
10.6	JAN 2014	21.2	FEB 2020	21.38	JAN 2014
10.7	FEB 2020	21.3	FEB 2020	21.39	JAN 2014
10.8	FEB 2020	21.4	FEB 2020	21.40	JAN 2014
10.9	FEB 2020	21.5	FEB 2020	21.41	JAN 2014
10.10	FEB 2020	21.6	FEB 2020	21.42	JAN 2014
		21.7	JAN 2014		
11.i	FEB 2020	21.8	JAN 2014	22.i	APR 2016
11.0	FEB 2020	21.9	FEB 2020	22.0	APR 2016
11.1	FEB 2020	21.10	FEB 2020	22.1	APR 2016
11.2	FEB 2020	21.11	FEB 2020	22.2	APR 2016
11.3	DEC 2021	21.12	FEB 2020	22.3	APR 2016
11.4	DEC 2021	21.13	FEB 2020	22.4	APR 2016
11.5	FEB 2020	21.14	FEB 2020	22.5	APR 2016
11.6	FEB 2020	21.15	FEB 2020	22.6	APR 2016
11.7	FEB 2020	21.16	FEB 2020	22.7	APR 2016
11.8	FEB 2020	21.17	JAN 2014	22.8	APR 2016
11.9	FEB 2020	21.18	JAN 2014		
11.10	FEB 2020	21.19	JAN 2014	25.i	DEC 2021
		21.20	JAN 2014	25.0	DEC 2021
12.i	JAN 2014	21.21	JAN 2014	25.1	DEC 2021
12.0	JAN 2014	21.22	JAN 2014	25.2	DEC 2021
12.1	APR 2016	21.23	JAN 2014	25.3	FEB 2020
12.2	APR 2016	21.24	JAN 2014	25.4	FEB 2020
		21.25	FEB 2020	25.5	FEB 2020
18.i	JAN 2014	21.26	FEB 2020	25.6	FEB 2020
18.0	JAN 2014	21.27	FEB 2020	25.7	DEC 2021
18.1	JAN 2014	21.28	FEB 2020	25.8	DEC 2021
18.2	JAN 2014	21.29	FEB 2020	25.9	DEC 2021
18.3	JAN 2014	21.30	FEB 2020	25.10	DEC 2021
18.4	JAN 2014	21.31	JAN 2014	25.11	DEC 2021
18.5	JAN 2014	21.32	JAN 2014	25.12	DEC 2021
18.6	JAN 2014	21.33	JAN 2014	25.13	DEC 2021
		21.34	JAN 2014	25.14	DEC 2021
21.i	FEB 2020	21.35	JAN 2014	25.15	DEC 2021
21.0	FEB 2020	21.36	JAN 2014	25.16	DEC 2021
21.1	FEB 2020	21.37	JAN 2014	25.17	DEC 2021

REVISION LOG

FEB 2024

<u>Page</u>	<u>Date</u>	<u>Page</u>	<u>Date</u>	<u>Page</u>	<u>Date</u>
25.18	DEC 2021	28.i	DEC 2021	28.35	DEC 2021
25.19	DEC 2021	28.0	DEC 2021	28.36	DEC 2021
25.20	DEC 2021	28.1	DEC 2021	28.37	DEC 2021
25.21	DEC 2021	28.2	DEC 2021	28.38	DEC 2021
25.22	DEC 2021	28.3	DEC 2021	28.39	FEB 2020
25.23	DEC 2021	28.4	DEC 2021	28.40	FEB 2020
25.24	DEC 2021	28.5	DEC 2021	28.41	FEB 2020
25.25	DEC 2021	28.6	DEC 2021	28.42	FEB 2020
25.26	DEC 2021	28.7	FEB 2020		
25.27	DEC 2021	28.8	FEB 2020	29.i	MAY 2016
25.28	DEC 2021	28.9	FEB 2020	29.0	MAY 2016
25.29	DEC 2021	28.10	FEB 2020	29.1	FEB 2020
25.30	DEC 2021	28.11	FEB 2020	29.2	FEB 2020
25.31	DEC 2021	28.12	FEB 2020	29.3	FEB 2020
25.32	DEC 2021	28.13	FEB 2020	29.4	FEB 2020
25.33	DEC 2021	28.14	FEB 2020	29.5	JAN 2014
25.34	DEC 2021	28.15	DEC 2021	29.6	JAN 2014
25.35	DEC 2021	28.16	DEC 2021	29.7	JAN 2014
25.36	DEC 2021	28.17	DEC 2021	29.8	JAN 2014
25.37	DEC 2021	28.18	DEC 2021	29.9	JAN 2014
25.38	DEC 2021	28.19	DEC 2021	29.10	JAN 2014
25.39	DEC 2021	28.20	DEC 2021	29.11	JAN 2014
25.40	DEC 2021	28.21	FEB 2020	29.12	JAN 2014
25.41	DEC 2021	28.22	FEB 2020	29.13	APR 2016
25.41A	DEC 2021	28.23	FEB 2020	29.14	APR 2016
25.41B	DEC 2021	28.24	FEB 2020	29.15	APR 2016
25.42	DEC 2021	28.25	FEB 2020	29.16	APR 2016
25.43	DEC 2021	28.26	FEB 2020	29.17	APR 2016
25.44	DEC 2021	28.27	FEB 2020	29.18	APR 2016
25.45	DEC 2021	28.28	FEB 2020		
25.46	DEC 2021	28.29	FEB 2020	32.i	DEC 2021
25.47	DEC 2021	28.30	FEB 2020	32.0	DEC 2021
25.48	DEC 2021	28.31	DEC 2021	32.1	APR 2016
25.49	DEC 2021	28.32	DEC 2021	32.2	APR 2016
25.50	DEC 2021	28.33	DEC 2021	32.3	APR 2016
		28.34	DEC 2021	32.4	APR 2016

REVISION LOG

FEB 2024

<u>Page</u>	<u>Date</u>	<u>Page</u>	<u>Date</u>	<u>Page</u>	<u>Date</u>
32.5	APR 2016	33.2	FEB 2020	52.15	FEB 2024
32.6	APR 2016	33.3	FEB 2020	52.16	FEB 2024
32.7	APR 2016	33.4	FEB 2020	52.17	FEB 2024
32.8	APR 2016	33.5	FEB 2024	52.18	FEB 2024
32.9	FEB 2024	33.6	FEB 2024	52.19	FEB 2024
32.10	FEB 2024	33.7	FEB 2024	52.20	FEB 2024
32.11	FEB 2024	33.8	FEB 2024	52.21	FEB 2024
32.11A	FEB 2024	33.9	FEB 2020	52.22	FEB 2024
32.11B	DEC 2021	33.10	DEC 2021		
32.12	DEC 2021	33.11	DEC 2021	53.i	FEB 2024
32.13	APR 2016	33.12	DEC 2021	53.0	FEB 2024
32.14	APR 2016	33.13	DEC 2021	53.1	APR 2016
32.15	APR 2016	33.14	DEC 2021	53.2	APR 2016
32.16	APR 2016	33.15	FEB 2020	53.3	APR 2016
32.17	APR 2016	33.16	FEB 2020	53.4	APR 2016
32.18	APR 2016	33.17	FEB 2020	53.5	APR 2016
32.19	APR 2016	33.18	FEB 2020	53.6	APR 2016
32.20	APR 2016	33.19	FEB 2020	53.7	APR 2016
32.21	APR 2016	33.20	FEB 2020	53.8	APR 2016
32.22	APR 2016			53.9	APR 2016
32.23	APR 2016	52.i	FEB 2024	53.10	APR 2016
32.24	APR 2016	52.0	FEB 2024	53.11	APR 2016
32.25	APR 2016	52.1	DEC 2021	53.12	APR 2016
32.26	APR 2016	52.2	DEC 2021	53.13	APR 2016
32.27	APR 2016	52.3	DEC 2021	53.14	APR 2016
32.28	APR 2016	52.4	DEC 2021	53.15	APR 2016
32.29	APR 2016	52.5	FEB 2024	53.16	APR 2016
32.30	APR 2016	52.6	FEB 2024	53.17	APR 2016
32.31	APR 2016	52.7	FEB 2024	53.18	APR 2016
32.32	APR 2016	52.8	FEB 2024	53.19	FEB 2020
32.33	APR 2016	52.9	FEB 2024	53.20	FEB 2020
32.34	APR 2016	52.10	FEB 2024	53.21	APR 2016
		52.11	FEB 2024	53.22	APR 2016
33.i	APR 2016	52.12	FEB 2024	53.23	FEB 2024
33.0	APR 2016	52.13	FEB 2024	53.24	FEB 2024
33.1	FEB 2020	52.14	FEB 2024	53.25	FEB 2024

REVISION LOG

FEB 2024

<u>Page</u>	<u>Date</u>	<u>Page</u>	<u>Date</u>	<u>Page</u>	<u>Date</u>
53.26	FEB 2024	62.7	FEB 2020	64.5	FEB 2020
53.27	FEB 2024	62.8	FEB 2020	64.6	FEB 2020
53.28	FEB 2024			64.7	JAN 2014
53.29	APR 2016	63.i	APR 2016	64.8	JAN 2014
53.30	APR 2016	63.0	APR 2016	64.9	FEB 2020
53.31	APR 2016	63.1	APR 2016	64.10	FEB 2020
53.32	APR 2016	63.2	APR 2016		
53.33	APR 2016	63.3	APR 2016	65.i	JAN 2014
53.34	APR 2016	63.4	APR 2016	65.0	JAN 2014
53.35	FEB 2024	63.5	APR 2016	65.1	FEB 2020
53.36	FEB 2024	63.6	APR 2016	65.2	FEB 2020
53.37	FEB 2024	63.7	APR 2016	65.3	JAN 2014
53.38	FEB 2024	63.8	APR 2016	65.4	JAN 2014
53.39	FEB 2024	63.9	JAN 2014	65.5	DEC 2021
53.40	FEB 2024	63.10	JAN 2014	65.6	DEC 2021
53.41	FEB 2024	63.11	JAN 2014	65.7	DEC 2021
53.42	FEB 2024	63.12	JAN 2014	65.8	DEC 2021
53.43	FEB 2024	63.13	FEB 2020	65.9	JAN 2014
53.44	FEB 2024	63.14	FEB 2020	65.10	JAN 2014
53.45	FEB 2024	63.15	FEB 2020	65.11	JAN 2014
53.46	FEB 2024	63.16	FEB 2020	65.12	JAN 2014
53.47	FEB 2024	63.17	FEB 2024		
53.48	FEB 2024	63.18	FEB 2024	67.i	JUN 2014
53.49	FEB 2024	63.19	FEB 2024	67.ii	JUN 2014
53.50	FEB 2024	63.20	FEB 2024	67.iii	JAN 2014
53.51	FEB 2024	63.21	FEB 2024	67.0	JAN 2014
53.52	FEB 2024	63.22	FEB 2024	67.1	JAN 2014
		63.23	APR 2016	67.2	JAN 2014
		63.24	APR 2016	67.3	APR 2016
62.i	APR 2016			67.4	APR 2016
62.0	APR 2016			67.5	FEB 2020
62.1	APR 2016	64.i	APR 2016	67.6	FEB 2020
62.2	APR 2016	64.0	APR 2016	67.7	APR 2016
62.3	FEB 2020	64.1	APR 2016	67.8	APR 2016
62.4	FEB 2020	64.2	APR 2016	67.9	APR 2016
62.5	APR 2016	64.3	JAN 2014	67.10	APR 2016
62.6	APR 2016	64.4	JAN 2014		

REVISION LOG

FEB 2024

<u>Page</u>	<u>Date</u>	<u>Page</u>	<u>Date</u>	<u>Page</u>	<u>Date</u>
67.11.....	JAN 2014	67.43.....	JAN 2014	67.79.....	JAN 2014
67.12.....	JAN 2014	67.44.....	JAN 2014	67.80.....	JAN 2014
67.13.....	JAN 2014	67.45.....	FEB 2020	67.81.....	FEB 2020
67.14.....	JAN 2014	67.46.....	FEB 2020	67.82.....	FEB 2020
67.15.....	JUN 2014	67.47.....	JAN 2014	67.83.....	JAN 2014
67.15A.....	JUN 2014	67.48.....	JAN 2014	67.84.....	JAN 2014
67.15B.....	FEB 2020	67.49.....	FEB 2020	67.85.....	FEB 2020
67.15C.....	FEB 2020	67.50.....	FEB 2020	67.86.....	FEB 2020
67.15D.....	JUN 2014	67.51.....	FEB 2020	67.87.....	JAN 2014
67.16.....	JUN 2014	67.52.....	FEB 2020	67.88.....	JAN 2014
67.17.....	FEB 2020	67.53.....	FEB 2020	67.89.....	FEB 2020
67.18.....	FEB 2020	67.54.....	FEB 2020	67.90.....	FEB 2020
67.19.....	APR 2016	67.55.....	FEB 2020	67.91.....	FEB 2020
67.20.....	APR 2016	67.56.....	FEB 2020	67.92.....	FEB 2020
67.21.....	FEB 2024	67.57.....	FEB 2020		
67.22.....	FEB 2024	67.58.....	FEB 2020	71.i.....	DEC 2021
67.23.....	FEB 2024	67.59.....	FEB 2020	71.0.....	DEC 2021
67.24.....	FEB 2024	67.60.....	FEB 2020	71.1.....	FEB 2020
67.25.....	JAN 2014	67.61.....	APR 2016	71.2.....	FEB 2020
67.26.....	JAN 2014	67.62.....	APR 2016	71.3.....	FEB 2020
67.27.....	FEB 2020	67.63.....	JAN 2014	71.4.....	FEB 2020
67.28.....	FEB 2020	67.64.....	JAN 2014	71.5.....	FEB 2020
67.29.....	JAN 2014	67.65.....	FEB 2020	71.6.....	FEB 2020
67.30.....	JAN 2014	67.66.....	FEB 2020	71.7.....	FEB 2020
67.31.....	FEB 2020	67.67.....	JAN 2014	71.8.....	FEB 2020
67.32.....	FEB 2020	67.68.....	JAN 2014	71.9.....	APR 2016
67.33.....	JAN 2014	67.69.....	FEB 2020	71.10.....	APR 2016
67.34.....	JAN 2014	67.70.....	FEB 2020	71.11.....	APR 2016
67.35.....	FEB 2020	67.71.....	JAN 2014	71.12.....	APR 2016
67.36.....	FEB 2020	67.72.....	JAN 2014	71.13.....	APR 2016
67.37.....	JAN 2014	67.73.....	JAN 2014	71.14.....	APR 2016
67.38.....	JAN 2014	67.74.....	JAN 2014	71.15.....	JAN 2014
67.39.....	JAN 2014	67.75.....	JAN 2014	71.16.....	JAN 2014
67.40.....	JAN 2014	67.76.....	JAN 2014	71.17.....	JAN 2014
67.41.....	FEB 2020	67.77.....	FEB 2020	71.18.....	JAN 2014
67.42.....	FEB 2020	67.78.....	FEB 2020	71.19.....	APR 2016

REVISION LOG

FEB 2024

<u>Page</u>	<u>Date</u>	<u>Page</u>	<u>Date</u>	<u>Page</u>	<u>Date</u>
71.20	APR 2016	71.52	JAN 2014		
71.21	FEB 2024	71.53	JAN 2014	79.i	APR 2016
71.22	FEB 2024	71.54	JAN 2014	79.0	APR 2016
71.23	APR 2016	71.55	JAN 2014	79.1	APR 2016
71.24	APR 2016	71.56	JAN 2014	79.2	APR 2016
71.25	APR 2016	71.57	FEB 2020	79.3	APR 2016
71.26	APR 2016	71.58	FEB 2020	79.4	APR 2016
71.27	JAN 2014	71.59	FEB 2020	79.5	DEC 2021
71.28	JAN 2014	71.60	FEB 2020	79.6	DEC 2021
71.29	JAN 2014	71.61	JAN 2014	79.7	DEC 2021
71.30	JAN 2014	71.62	JAN 2014	79.8	DEC 2021
71.31	JAN 2014	71.63	APR 2016	79.9	DEC 2021
71.32	JAN 2014	71.64	APR 2016	79.10	DEC 2021
71.33	JAN 2014	71.65	APR 2016	79.11	DEC 2021
71.34	JAN 2014	71.66	APR 2016	79.12	DEC 2021
71.35	JAN 2014				
71.36	JAN 2014	76.i	JUN 2014	90.i	JAN 2014
71.37	JAN 2014	76.0	JUN 2014	90.0	JAN 2014
71.38	JAN 2014	76.1	FEB 2020	90.1	JAN 2014
71.39	JAN 2014	76.2	FEB 2020	90.2	JAN 2014
71.40	JAN 2014	76.3	MAY 2016	90.3	JAN 2014
71.41	JAN 2014	76.4	MAY 2016	90.4	JAN 2014
71.42	JAN 2014	76.5	MAY 2016	90.5	JAN 2014
71.43	JAN 2014	76.6	MAY 2016	90.6	JAN 2014
71.44	JAN 2014	76.7	APR 2016	90.7	JAN 2014
71.45	JAN 2014	76.8	APR 2016	90.8	JAN 2014
71.46	JAN 2014	76.9	FEB 2020	90.9	JAN 2014
71.47	JAN 2014	76.10	FEB 2020	90.10	JAN 2014
71.48	JAN 2014	76.11	JAN 2014	90.11	JAN 2014
71.49	DEC 2021	76.12	JAN 2014	90.12	JAN 2014
71.49A	DEC 2021	76.13	JAN 2014	90.13	JAN 2014
71.49B	DEC 2021	76.14	JAN 2014	90.14	JAN 2014
71.49C	DEC 2021	76.15	JAN 2014	90.15	JAN 2014
71.49D	DEC 2021	76.16	JAN 2014	90.16	JAN 2014
71.50	DEC 2021	76.17	FEB 2020	90.17	JAN 2014
71.51	JAN 2014	76.18	FEB 2020	90.18	JAN 2014

REVISION LOG

FEB 2024

<u>Page</u>	<u>Date</u>	<u>Page</u>	<u>Date</u>	<u>Page</u>	<u>Date</u>
90.19	JAN 2014	92.18	FEB 2020	95.4	FEB 2020
90.20	JAN 2014	92.19	FEB 2020	95.5	FEB 2020
90.21	JAN 2014	92.20	FEB 2020	95.6	FEB 2020
90.22	JAN 2014	92.21	JAN 2014	95.7	FEB 2020
90.23	JAN 2014	92.22	JAN 2014	95.8	FEB 2020
90.24	JAN 2014	92.23	JAN 2014	95.9	FEB 2020
90.25	JAN 2014	92.24	JAN 2014	95.10	FEB 2020
90.26	JAN 2014	92.25	JAN 2014	95.11	FEB 2020
90.27	JAN 2014	92.26	JAN 2014	95.12	FEB 2020
90.28	JAN 2014	92.27	JAN 2014	95.13	FEB 2020
90.29	JAN 2014	92.28	JAN 2014	95.14	FEB 2020
90.30	JAN 2014	92.29	JAN 2014	95.15	FEB 2020
		92.30	JAN 2014	95.16	FEB 2020
92.i	FEB 2020	92.31	JAN 2014	95.17	FEB 2020
92.0	FEB 2020	92.32	JAN 2014	95.18	FEB 2020
92.1	JAN 2014	92.33	JAN 2014	95.19	FEB 2020
92.2	JAN 2014	92.34	JAN 2014	95.20	FEB 2020
92.3	JAN 2014	92.35	FEB 2020	95.21	FEB 2020
92.4	JAN 2014	92.36	FEB 2020	95.22	FEB 2020
92.5	JAN 2014	92.37	FEB 2020	95.23	FEB 2020
92.6	JAN 2014	92.38	FEB 2020	95.24	FEB 2020
92.7	JAN 2014			95.25	FEB 2020
92.8	JAN 2014	94.i	DEC 2021	95.26	FEB 2020
92.9	JAN 2014	94.0	DEC 2021	95.27	FEB 2020
92.10	JAN 2014	94.1	DEC 2021	95.28	FEB 2020
92.11	JAN 2014	94.2	DEC 2021	95.29	FEB 2020
92.12	JAN 2014	94.3	DEC 2021	95.30	FEB 2020
92.13	JAN 2014	94.4	DEC 2021	95.31	FEB 2020
92.14	JAN 2014			95.32	FEB 2020
92.15	JAN 2014	95.i	FEB 2020	95.33	FEB 2020
92.16	JAN 2014	95.ii	FEB 2020	95.34	FEB 2020
92.17	FEB 2020	95.iii	FEB 2020	95.35	FEB 2020
92.17A	FEB 2020	95.0	FEB 2020	95.36	FEB 2020
92.17B	FEB 2020	95.1	FEB 2020	95.37	FEB 2020
92.17C	FEB 2020	95.2	FEB 2020	95.38	FEB 2020
92.17D	FEB 2020	95.3	FEB 2020	95.39	FEB 2020

REVISION LOG

FEB 2024

<u>Page</u>	<u>Date</u>	<u>Page</u>	<u>Date</u>	<u>Page</u>	<u>Date</u>
95.40	FEB 2020	95.76	FEB 2020	96.17	JAN 2014
95.41	FEB 2020	95.77	FEB 2020	96.18	JAN 2014
95.42	FEB 2020	95.78	FEB 2020	96.19	JAN 2014
95.43	FEB 2020	95.79	FEB 2020	96.20	JAN 2014
95.44	FEB 2020	95.80	FEB 2020	96.21	JAN 2014
95.45	FEB 2020	95.81	FEB 2020	96.22	JAN 2014
95.46	FEB 2020	95.82	FEB 2020	96.23	JAN 2014
95.47	FEB 2020	95.83	FEB 2020	96.24	JAN 2014
95.48	FEB 2020	95.84	FEB 2020	96.25	JAN 2014
95.49	FEB 2020			96.26	JAN 2014
95.50	FEB 2020	96.i	DEC 2021	96.27	JAN 2014
95.51	FEB 2020	96.ii	DEC 2021	96.28	JAN 2014
95.52	FEB 2020	96.iii	JAN 2014	96.29	JAN 2014
95.53	FEB 2020	96.0	JAN 2014	96.30	JAN 2014
95.54	FEB 2020	96.1	JAN 2014	96.31	JAN 2014
95.55	FEB 2020	96.2	JAN 2014	96.32	JAN 2014
95.56	FEB 2020	96.3	JAN 2014	96.33	JAN 2014
95.57	FEB 2020	96.4	JAN 2014	96.34	JAN 2014
95.58	FEB 2020	96.5	JAN 2014	96.35	JAN 2014
95.59	FEB 2020	96.6	JAN 2014	96.36	JAN 2014
95.60	FEB 2020	96.7	JAN 2014	96.37	JAN 2014
95.61	DEC 2021	96.8	JAN 2014	96.38	JAN 2014
95.62	DEC 2021	96.9	JAN 2014	96.39	JAN 2014
95.63	FEB 2020	96.10	JAN 2014	96.40	JAN 2014
95.64	FEB 2020	96.11	DEC 2021	96.41	JAN 2014
95.65	FEB 2020	96.12	DEC 2021	96.42	JAN 2014
95.66	FEB 2020	96.12A	DEC 2021	96.43	FEB 2020
95.67	FEB 2020	96.12B	DEC 2021	96.44	FEB 2020
95.68	FEB 2020	96.12C	DEC 2021	96.45	JAN 2014
95.69	FEB 2020	96.13	DEC 2021	96.46	JAN 2014
95.70	FEB 2020	96.13A	DEC 2021	96.47	FEB 2020
95.71	FEB 2020	96.13B	DEC 2021	96.48	FEB 2020
95.72	FEB 2020	96.13C	DEC 2021	96.49	FEB 2020
95.73	FEB 2020	96.14	DEC 2021	96.50	FEB 2020
95.74	FEB 2020	96.15	DEC 2021	96.51	FEB 2020
95.75	FEB 2020	96.16	DEC 2021	96.52	FEB 2020

REVISION LOG

FEB 2024

<u>Page</u>	<u>Date</u>	<u>Page</u>	<u>Date</u>	<u>Page</u>	<u>Date</u>
96.53	FEB 2020	97.2	FEB 2020	97.36	FEB 2020
96.54	FEB 2020	97.3	FEB 2020	97.37	FEB 2020
96.55	JAN 2014	97.4	FEB 2020	97.38	FEB 2020
96.56	JAN 2014	97.5	FEB 2020	97.39	FEB 2020
96.57	JAN 2014	97.6	FEB 2020	97.40	FEB 2020
96.58	JAN 2014	97.7	FEB 2020	97.41	FEB 2020
96.59	JAN 2014	97.8	FEB 2020	97.42	FEB 2020
96.60	JAN 2014	97.9	FEB 2020	97.43	FEB 2020
96.61	JAN 2014	97.10	FEB 2020	97.44	FEB 2020
96.62	JAN 2014	97.11	FEB 2020	97.45	FEB 2020
96.63	FEB 2024	97.12	FEB 2020	97.46	FEB 2020
96.63A	FEB 2024	97.13	FEB 2020	97.47	FEB 2020
96.63B	FEB 2020	97.14	FEB 2020	97.48	FEB 2020
96.63C	FEB 2020	97.15	FEB 2020	97.49	FEB 2020
96.63D	FEB 2020	97.16	FEB 2020	97.50	FEB 2020
96.64	FEB 2020	97.17	FEB 2020	97.51	FEB 2020
96.65	JAN 2014	97.18	FEB 2020	97.52	FEB 2020
96.66	JAN 2014	97.19	FEB 2020	97.53	FEB 2020
96.67	JAN 2014	97.20	FEB 2020	97.54	FEB 2020
96.68	JAN 2014	97.21	FEB 2020	97.55	FEB 2020
96.69	JAN 2014	97.22	FEB 2020	97.56	FEB 2020
96.70	JAN 2014	97.23	FEB 2020	97.57	FEB 2020
96.71	JAN 2014	97.23A	FEB 2020	97.58	FEB 2020
96.72	JAN 2014	97.23B	FEB 2020	97.59	FEB 2020
96.73	JAN 2014	97.24	FEB 2020	97.60	FEB 2020
96.74	JAN 2014	97.25	FEB 2020	97.61	FEB 2020
96.75	JAN 2014	97.26	FEB 2020	97.62	FEB 2020
96.76	JAN 2014	97.27	FEB 2020		
96.77	JAN 2014	97.28	FEB 2020	99.i	FEB 2020
96.78	JAN 2014	97.29	FEB 2020	99.0	FEB 2020
96.79	JAN 2014	97.30	FEB 2020	99.1	FEB 2020
96.80	JAN 2014	97.31	FEB 2020	99.2	FEB 2020
		97.32	FEB 2020	99.3	FEB 2020
97.i	FEB 2020	97.33	FEB 2020	99.4	FEB 2020
97.0	FEB 2020	97.34	FEB 2020	99.5	FEB 2020
97.1	FEB 2020	97.35	FEB 2020	99.6	FEB 2020

REVISION LOG**FEB 2024**

<u>Page</u>	<u>Date</u>	<u>Page</u>	<u>Date</u>	<u>Page</u>	<u>Date</u>
99.7	FEB 2020				
99.8	FEB 2020				
99.9	FEB 2020				
99.10	FEB 2020				
99.11	FEB 2020				
99.12	FEB 2020				
99.13	FEB 2020				
99.14	FEB 2020				
99.15	FEB 2020				
99.16	FEB 2020				
99.17	FEB 2020				
99.18	FEB 2020				
100.i	DEC 2021				
100.0	DEC 2021				
100.1	FEB 2024				
100.2	FEB 2024				
100.3	FEB 2024				
100.4	FEB 2024				
100.5	FEB 2024				
100.6	FEB 2024				
100.7	FEB 2024				
100.8	FEB 2024				
100.9	FEB 2024				
100.10	FEB 2024				
100.11	FEB 2024				
100.12	FEB 2024				

Intentionally Blank