

R22-series Fuel System Upgrade Kit Instructions

Upgrades earlier bladder tank fuel systems to include fuel line breakaway couplings. Applicable to R22 S/N 4814 & prior, with either factory-installed bladder tanks, or bladder tanks installed per KI-217-1 Revision B thru G; contents of this kit are included in KI-217-1 Revision H or subsequent. Previous compliance with R22 Service Bulletins SB-109A and SB-105 is required. This kit meets the standards of Section 317 of the FAA Reauthorization Act of 2018 (see: FAA SAIB SW-17-31R2).

NOTE

Visit www.robinsonheli.com to verify kit instructions are current revision. Review instructions before installation; contact RHC Technical Support with questions. Verify kit contents match list; contact RHC Customer Service if parts are missing or damaged.

ITEM	PART NUMBER	KIT CONTENTS	QTY
1	KI-217-3Instr.	Kit Instructions	1
2	A457-19	Cap	2
3	A729-79	Tube	2
4	A731-10	Tube Assembly	1
5	A880-536	Adapter (CRES; alternate p/n A880-566, steel)	1
6	A880-636	Elbow (CRES; alternate p/n A880-666, steel)	4
7	A880-936	Union (CRES; alternate p/n A880-966, steel)	1
8	A880-1136	Tee (CRES; alternate p/n A880-1166, steel)	1
9	B209-1	Plug	1
10	C595-1	Hose Assembly	1
11	D277-6	Clamp	4
12	MS3367-5-9+	Ty-rap (Note: "+" in contents part number indicates 20-qty pack)	1
13	MS3367-6-0	Ty-rap	1
14	MS20615-4M2.5+	Rivet (Note: "+" in contents part number indicates 5-qty pack)	1
15	MS29512-06	Packing	2
16	MS35489-6	Grommet	3

Consumables

Refer to R22 Maintenance Manual (MM) § 23-70 for approved materials list.

- A257-6 Grease
- B270-1 Sealant
- B270-6 Sealant

Kit Instructions**CAUTION**

Temporarily cap fuel fittings when opened.

WARNING

Fuel vapors are explosive. Do not use electric tools in vicinity of an opened fuel system.

1. Turn battery switch off. Remove left side engine skirt. Remove main tank per MM § 12.110. Remove and discard D205-33 (interconnect) hose and AN815-6D union (with packing) from main tank.
2. Refer to R22 Illustrated Parts Catalog (IPC) Figure 28-15. Disconnect A726-1 line assembly from A457-15 (0363-6-6) bulkhead union; remove union's nut and washer. Remove fuel shut-off valve with attached elbows, A657-1 nut, A656-1 sleeve (inside nut), bulkhead union, and washer(s). Note orientation of elbows prior to removal, then remove elbows, nut, sleeve, bulkhead union, and washer(s) from fuel valve. Discard both MS20822-6D (or AN822-6D) elbows.
3. Refer to Figure 1. Verify A670-1 fuel shut-off valve is Revision I or subsequent (Refer to R22 Service Bulletin SB-105). Assemble fuel shut-off valve to associated parts, and install as follows:
 - a. Install A457-15 bulkhead union, A657-1 nut, and A656-1 sleeve on top side of bulkhead union, then install flared-fitting side of new A880-636 elbow in A657-1 nut. Clamp elbow flats in padded vice (do not damage elbow threads) and special torque bulkhead union to 120 In.-lb. Remove assembly from vise.
 - b. Apply B270-6 sealant sparingly to tapered pipe threads of elbow (do not apply sealant to first thread). Clamp A670-1 fuel valve in padded vise and install elbow with attached bulkhead union in valve outlet (arrow on handle points to outlet when in OFF position). Standard torque elbow per MM § 23-32 and align fitting as required.
 - c. Apply B270-6 sealant sparingly to tapered pipe threads of other new A880-636 elbow (do not apply sealant to first thread). Install tapered-thread side of elbow in fuel valve inlet. Standard torque elbow per MM § 23-32 and align fitting as required.
 - d. Position assembled valve and bulkhead union with NAS1149F0932P washer through firewall, and position seat back for installation. As required, install NAS1149F0932P washers between bulkhead union nut and the top of the firewall to position valve at correct height. Remove seat back.
 - e. Inside engine compartment, install washer and nut on bulkhead union and special torque nut to 100 in.-lb. Install A726-1 line assembly to A457-15 union and special torque B-nut to 285 in.-lb; torque stripe per MM Figure 2-1.
4. Refer to IPC Figure 28-15 and Figure 1. Disconnect A726-1 line assembly from A666-1 gascolator inlet MS20822-6D (or AN822-6D) elbow; discard elbow. Apply B270-6 sealant sparingly to tapered pipe threads of new A880-636 elbow (do not apply sealant to first thread). Install tapered-thread side of elbow in inlet of gascolator. Standard torque elbow per MM § 23-32 and align fitting as required. Install A726-1 line assembly to elbow and special torque B-nut to 285 in.-lb; torque stripe per MM Figure 2-1.

Kit Instructions (continued)

5. Refer to IPC Figure 28-15 and Figure 1. Disconnect B283-6 hose assembly from gascolator and carburetor. Remove and discard AN816-6D nipple (gascolator) and MS20822-6D elbow (carburetor). Apply B270-6 sealant sparingly to tapered pipe threads of new A880-636 elbow (do not apply sealant to first thread). Install tapered-thread side of elbow in carburetor. Standard torque elbow to 85 in.-lb and align fitting as required. Repeat procedure for gascolator outlet and install either A880-1136 tee (if optional primer installed), or A880-536 adapter. Install tapered-thread side in gascolator and standard torque tee or adapter to 85 in.-lb and align tee as required. Install B283-6 hose assembly and torque B-nuts to 120 in.lbs; torque stripe per MM Figure 2-1.
6. Refer to IPC Figure 28-19. If B128-2 (aux tank) drain tube is installed, remove tube, A456-1 drain, and associated parts. Do not remove B128-1 (horizontal firewall) drain tube. Discard removed drain tube and associated parts. Install (2) MS20615-4M2.5 rivets in vacated rivet holes on horizontal firewall. Apply B270-1 sealant around center hole and install (1) B209-1 plug. Secure plug by bending tangs on engine-side of firewall. Verify security. Apply a sufficient amount of B270-1 sealant to cover tangs.
7. Refer to Figure 2, Detail A-A. Lubricate (1) MS29512-06 packing using A257-6 grease and assemble to new A880-936 union. Install union with packing to main tank drain fitting and special torque to 200 in.-lb. Connect new C595-1 hose assembly to union, positioning opposite (90° end) so that it will be vertical when connecting to aux tank. Special torque hose nut to 120 in.-lb and torque stripe per MM Figure 2-1.
8. Install main tank per MM § 12.110 B, steps 1-5. Install A729-62 vent tube to main tank using B277-4 clamp. Tighten clamp. Install (1) A457-19 cap on each lower fuel (main & aux) tank vent fittings and secure using (1) D277-6 clamp (see Figure 4). Verify security.
9. Refer to Figure 2. Connect C595-1 hose assembly to aux tank strainer assembly. Special torque hose nut 120 in.-lb and torque stripe per MM Figure 2-1. Install two MS3367-5-9 ty-raps around C595-1 and D205-34 hose assemblies and B833-2 tab, but do not tighten. Maintain 0.25 in. minimum clearance for C595-1 hose with frame assembly and firewall, and for D205-34 hose with firewall and support. Install one MS3367-5-9 ty-rap around hose assemblies at inboard location shown. Cinch ty-raps until snug without over-tightening, and trim tips flush with heads.
10. Refer to IPC Figure 28-13. Remove and discard: A731-4 vent tubes, attaching MS21919WDG4 & B277-56 clamps & installation hardware, A729-61 tubes, A729-49 tube, attaching B576-6 tab & installation hardware. Remove lower (mast fairing) ribs.
11. Refer to Figure 3. Lay out and drill one 0.438 inch diameter hole in A261-4 rib as shown. Install (3) new MS35489-6 grommets in A261-3 and A261-4 ribs for new pitot tube location and vent tubes. Install ribs on mast tube and secure with clamp. Install screws securing ribs together.
12. Refer to Figure 4. Insert (rollover) valve stems through rib grommets. Secure new A731-10 tube assembly to mast tube with one MS3367-6-0 ty-rap at location shown. Install two new A729-79 tubes on A731-10 tube assembly using (2) D277-6 clamps. Verify security. Install opposite end A729-79 tubes on valve stems, and secure tubes to valves with (2) D277-6 clamps. Verify security.

Kit Instructions (continued)

13. Perform vent system check as follows:

NOTE
A hand-operated inflation pump, such as bicycle tire pump, may be used to create air flow necessary for system check.

- a. Attach a temporary hose to open end of one tube of A731-10 tube assembly; block open end of other tube.
 - b. With fuel caps installed, blow into the hose (do not use compressed air) and verify no air leaks.
 - c. Remove fuel cap from main tank and blow into the hose. Verify air escapes out main tank. Secure cap on main tank.
 - d. Repeat step c. on aux tank. Secure cap on aux tank.
 - e. Remove temporary block on tube end and blow into the hose. Verify air escapes thru open vent tube. If air does not blow out the other vent, remove obstruction(s) in vent assembly or in fuel bladder(s) and repeat check.
 - f. Remove hose and secure fuel caps.
14. Route pitot line through grommet in rib and connect pitot line. Close mast fairing and perform pitot system leak test per MM § 13-10.
15. Perform minimum fuel flow check per MM § 12.600.
16. Install left engine skirt and left backrest assembly.
17. Revise helicopter’s Weight and Balance Record in R22 Pilot’s Operating Handbook (POH) Section 6 to reflect this installation by incorporating the following data:

Add:

Item	Weight	Long. Arm	Long. Moment	Lat. Arm	Lat. Moment
KI-217-3 Fuel System Upgrade Kit	+0.7 lb	98.2 in.	+68.74 in.-lb	1.5 in.	+1.05 in.-lb

18. Have a qualified person run-up and shutdown helicopter per Pilot’s Operating Handbook. Verify no fuel leaks.
19. Turn fuel valve OFF. Remove and clean gascolator bowl and filter screen. Verify no deterioration of gasket. If gascolator bowl is secured by threaded collar and ring, lightly lube threads and ring with A257-6 grease. Reassemble and turn fuel valve on. Safety wire after ensuring no leaks occur. Verify drain valve is secure and torque-stripped.
20. Make appropriate maintenance record entries.

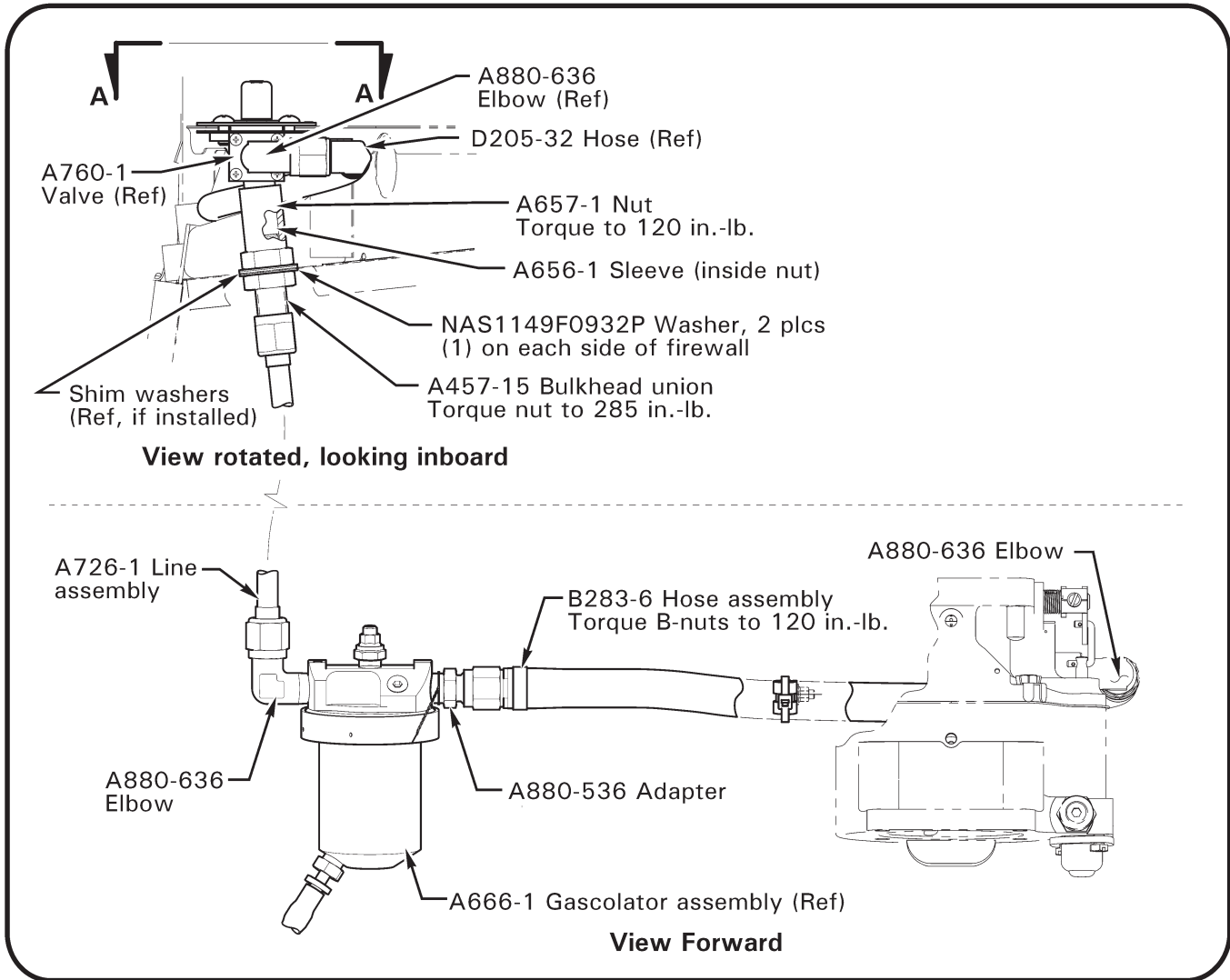
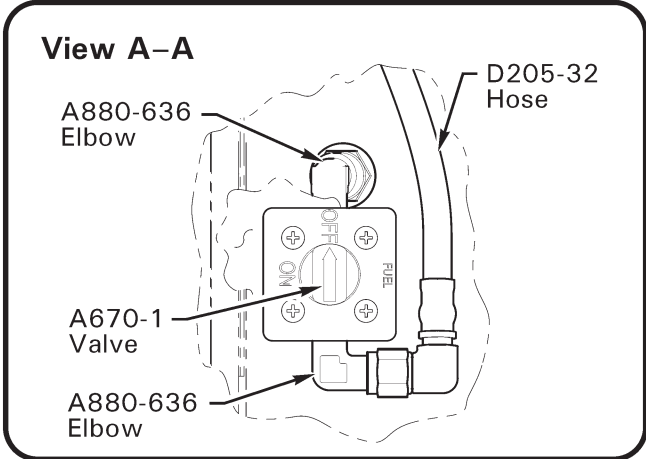
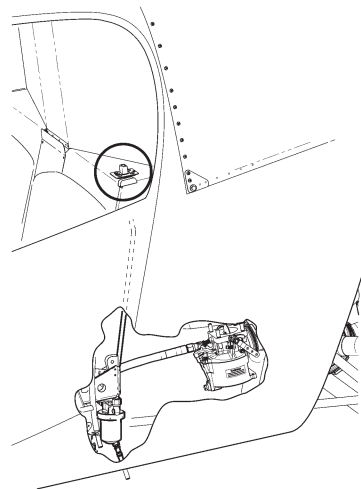

FIGURE 1 Installation of A880-series parts

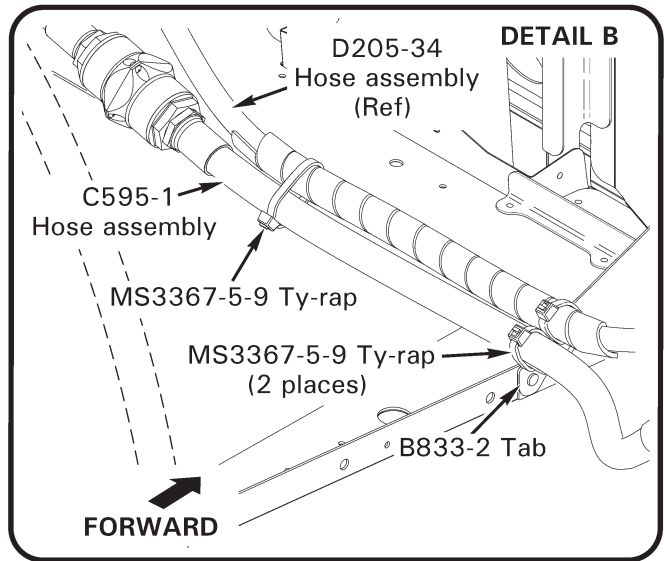
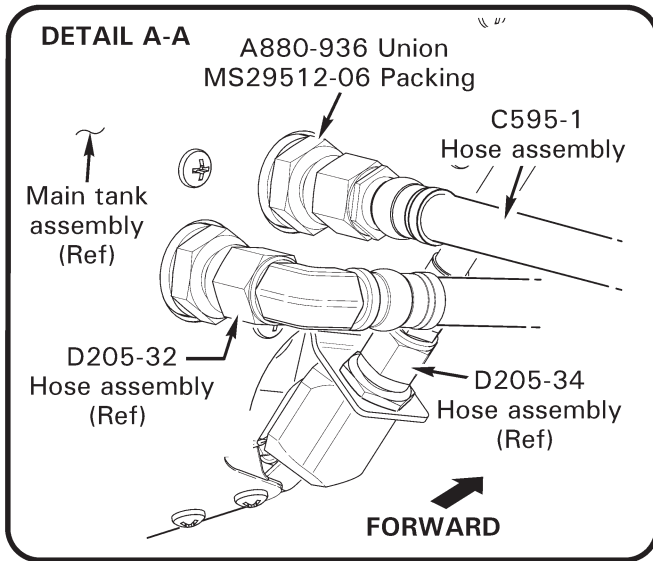
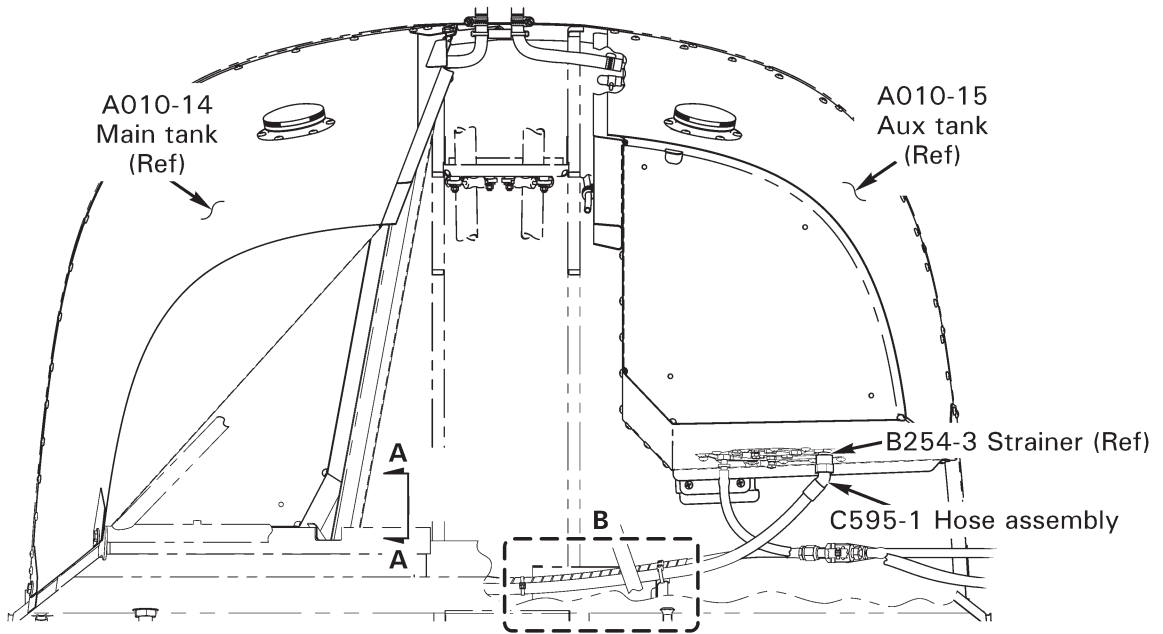

FIGURE 2 Installation of C595-1 hose assembly

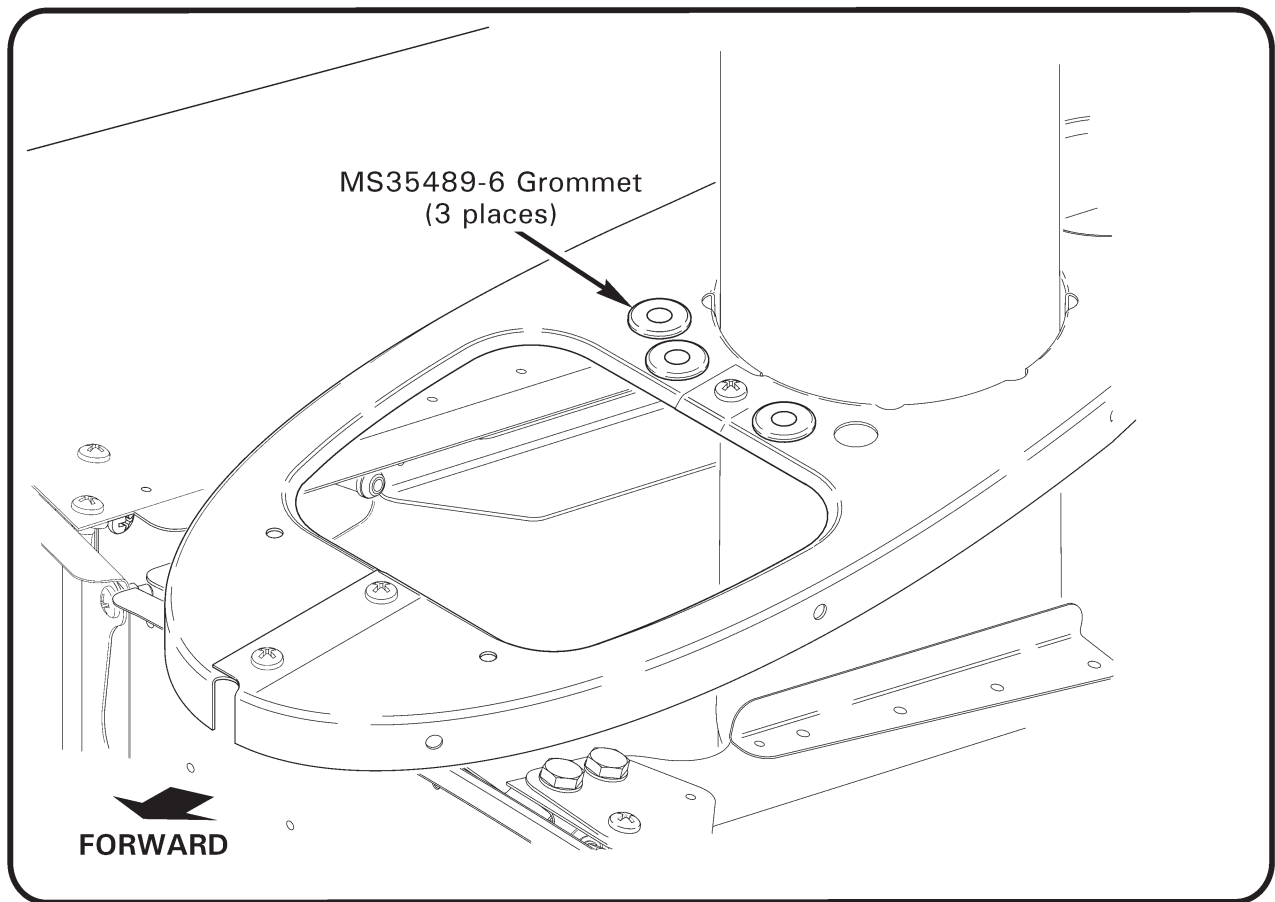
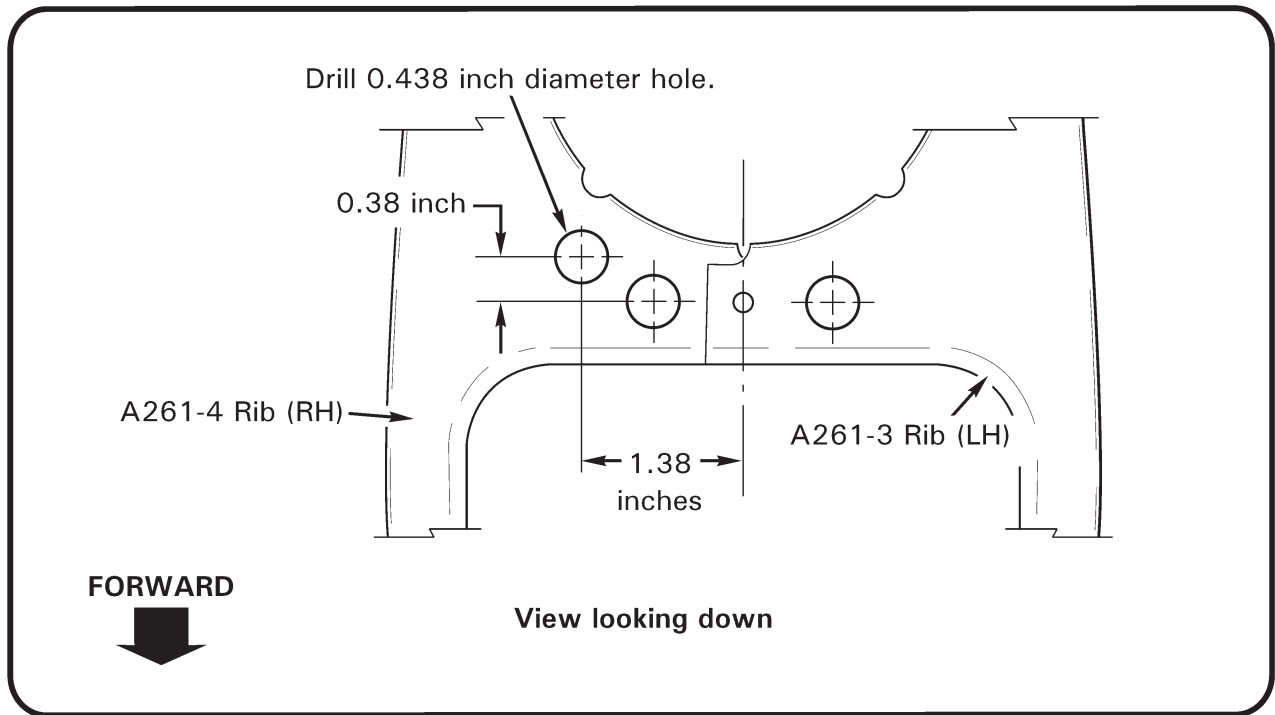

FIGURE 3

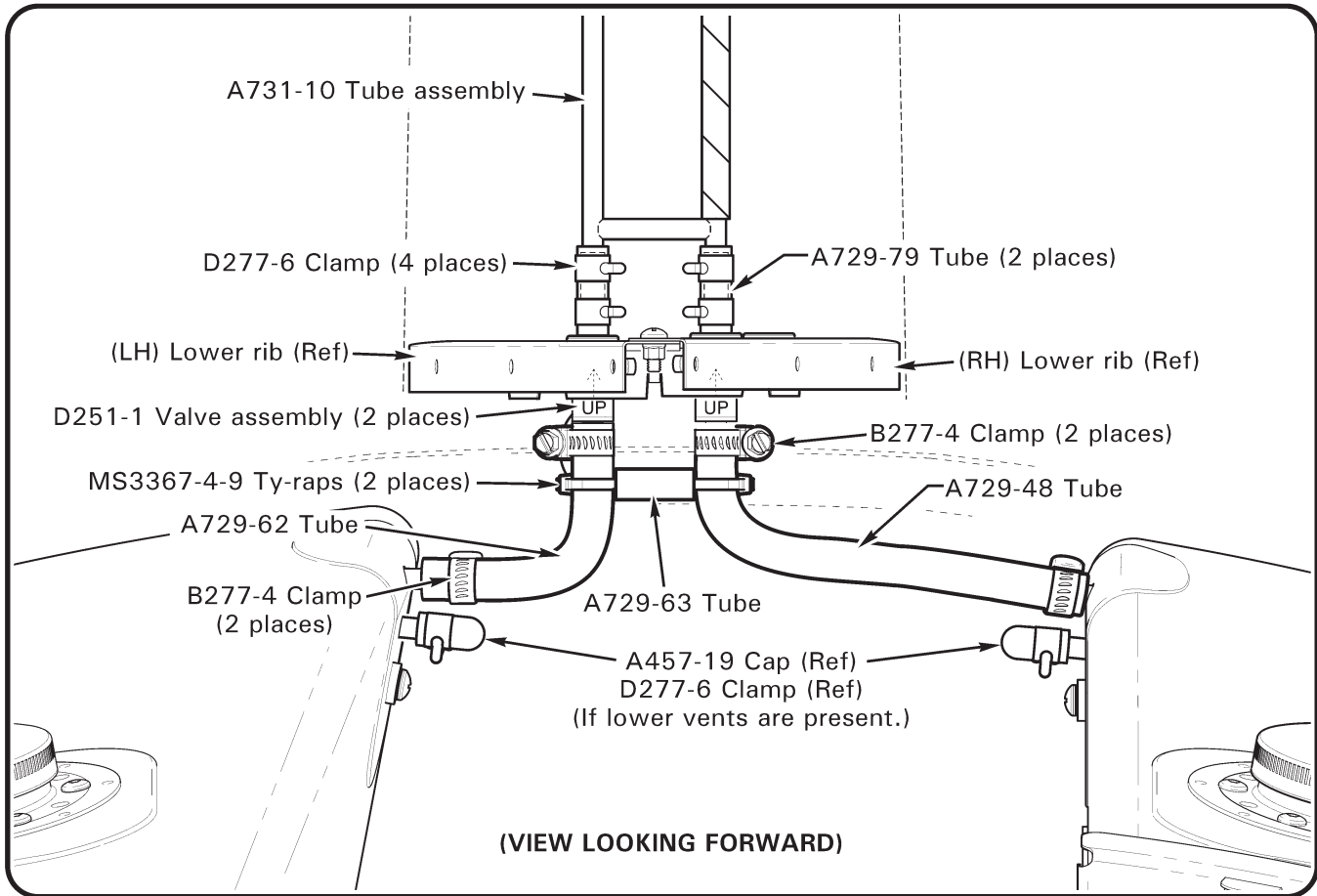
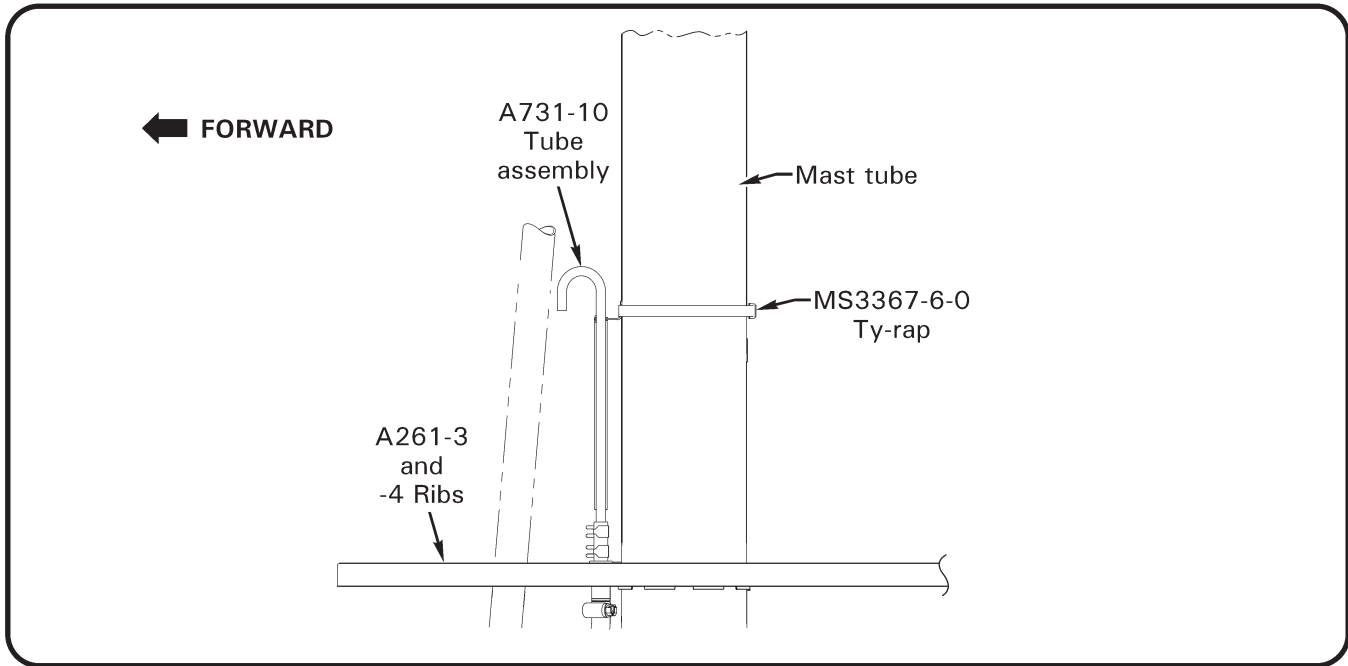

FIGURE 4 Upgraded fuel tank venting system