

R66 Accessory Support Installation Kit Instructions

Use KI-254-4A for RH accessory support and KI-254-4B for LH accessory support installation. KI-254-4C is required to be installed concurrently on R66 S/N 0519 & prior for airframe harness wiring upgrade.

NOTE

Visit www.robinsonheli.com to verify kit instructions are current revision. Review instructions before installation; contact RHC Technical Support with questions. Verify kit contents match list; contact RHC Customer Service if parts are missing or damaged.

ITEM	PART NUMBER	KIT CONTENTS	QTY PER KI-254 -4A	QTY PER KI-254 -4B	QTY PER KI-254 -4C
1	KI-254-4Instr.	Kit Instructions	1	1	1
2	A912-7	Pocket Assembly	1	1	0
3	A913-1	Strip	1	1	0
4	A913-6	Strip	2	2	0
5	B204-2	Rivet	7	7	0
6	B263-34	Housing – 3-Pin	1	1	0
7	B297-5	Circuit Breaker (5-amp)	0	0	1
8	B630-1	Clamp Assembly (includes [1] B631-1 clamp assembly) . .	1	1	0
9	B631-1	Clamp Assembly	1	1	0
10	B844-3	Harness Assembly – USB Power Plug	1	1	0
11	B844-4	Harness Assembly – Accessory Power Plug	0	0	1
12	B844-5	Fuse Assembly (supplied with D275-205 fuse)	0	0	1
13	D275-205	Fuse (AGC-5-R)	1	1	0
14	F654-49	Decal – “AUX PWR 5V”	1	1	0
15	G682-14	Decal – “MAXIMUM LOAD 10 LB (4.5 KG)”	1	1	0
16	G682-15	Decal – “CAUTION...”	1	1	0
17	G703-12	Shim	3	3	0
18	G703-15	Support Assembly - LH	0	1	0
19	G703-16	Support Assembly - RH	1	0	0
20	RAM-238U	Mount (1.5 inch diameter ball, RAM size “C”)	1	1	0
21	6430202-2	TA202 USB Port	1	1	0
22	MS21042L08	Nut	4	4	0
23	MS27039C0806	Screw	4	4	0
24	MS3367-4-9+	Ty-Rap (Note: “+” in contents part number indicates 20-qty pack)	1	1	0
25	MS3367-5-9+	Ty-Rap (Note: “+” in contents part number indicates 20-qty pack)	0	0	1
26	MS35206-213	Screw	2	2	0
27	MS35206-226	Screw	0	0	1
28	NAS1149FN632P+	Washer (Note: “+” in part number indicates 20-qty pack) . .	1	1	0

ITEM	PART NUMBER	KIT CONTENTS	QTY PER KI-254 -4A	QTY PER KI-254 -4B	QTY PER KI-254 -4C
29	NAS1149FN816P+	Washer (Note: "+" in part number indicates 20-qty pack) . .	1	1	0
30	NAS1351-3-24	Screw	2	2	0
31	NAS1352-08-8	Screw	1	1	0

Special Tools:

- Drilling and deburring tools
- Clecos (sheet metal fastener)

Kit Instructions

1. Ensure ignition switch is OFF; remove key. Turn BATTERY switch OFF. Disconnect lead-acid battery per Maintenance Manual (MM) § 96-11A or lithium-ion battery per MM § 96-12A as applicable.
2. Remove ground handling wheels and ensure helicopter is laterally level per MM § 8-11.2.
3. Using masking tape (or similar product) temporarily mark location of avionics on F359 panel. Remove lower console anchor screws, avionics face, and avionics from lower console. Cover exposed avionics with clean shop towel or tape to catch drilling debris.

NOTE

Parenthetic dash numbers, such as (-2886), indicate number marked on wiring insulation (if single conductor), or jacket (if multi-conductor and/or shielded).

4. **For helicopter S/N 0520 & subsequent:**
Open circuit breaker panel. Locate existing fuse holder along wire (-626) and install D275-205 fuse (if not previously installed at factory). Close and secure circuit breaker panel.
5. **For helicopter S/N 0519 & prior:**
 - a. Refer to Figure 1. Open circuit breaker panel. Lay out location for 0.143–0.149 inch diameter hole on F490 panel as shown. Verify adequate clearance on reverse side then drill 0.143–0.149 inch diameter hole using drill stop. Deburr hole and clean up debris. Install B844-5 fuse assembly using MS35206-227 screw, NAS1149FN616P washer under screw head, and MS21042L06 nut (parts supplied with fuse assembly).
 - b. Locate existing AUX PWR B297-2 (2-amp) circuit breaker. Remove circuit breaker and install B297-5 5-amp circuit breaker. Connect B260-2 terminal of B844-5 fuse assembly to newly installed AUX PWR 5-amp circuit breaker using supplied MS35206-226 screw and existing lockwasher. Install D275-205 fuse (supplied with B844-5 fuse assembly) in fuse holder.
 - c. Route B844-4 harness assembly from center of console to circuit breaker (mating assembly performed in step 11). Carefully remove ty-raps from airframe harness, then secure B844-4 harness assembly along airframe harness using appropriately sized ty-raps . Cinch ty-rap until snug without over-tightening, and trim tip flush with head. Connect harness assembly and B844-5 fuse assembly; verify security.
 - d. Install B844-4 harness wire (-2627) to ground screw; verify security. Close and secure circuit breaker panel.

Kit Instructions (continued)

NOTE

Installation instructions are given for RH accessory support; LH accessory support installation is similar.

6. Refer to Figure 2. Position inboard flange of G703 support assembly adjacent to existing rivet head as shown; temporarily secure support assembly. Horizontally level $\pm 1^\circ$ and perpendicular to F359 console-support panel in horizontal plane $\pm 1^\circ$. Verify potential match-drilled holes at support's inboard flange will not damage edge, or flange of any installed internal stiffener; adjust support location as required within stated limits. Check leveling and adequate clearance on reverse side prior to drilling. Subsequent holes are based on accurately locating support assembly installation holes. Using a drill stop, progressively match drill and install a cleco in (4) 0.169–0.175 inch diameter holes, two places per flange. Remove clecos and support assembly.
7. Lay out location for 0.5 inch diameter hole as shown in Figure 2. Verify adequate clearance on reverse side; using a drill stop drill 0.5 inch diameter hole on panel.
8. Refer to Figure 3. Lay out upper-aft hole location for A912-7 pocket assembly, ensuring location will not interfere with right hand flange of avionics face. Then, using pocket and A913-1 & A913-6 strips as templates, lay out remaining (6) holes. Verify clearance on reverse side; using a drill stop and strips as guides progressively match drill and install a cleco in (7) 0.128 inch diameter holes.
9. Remove clecos, pocket, and strips. Deburr newly drilled holes as required and clean up debris. At installer's discretion, alodine and/or prime/paint hole(s) edges as described in NOTE below.

NOTE

After trimming or filing aluminum, finish edges as follows: Deburr trimmed edges with 220-grit or finer wet-or-dry aluminum oxide abrasive paper. Solvent-clean deburred edge and apply Bonderite M-CR 1132, or Bonderite M-CR 1201 Aero in accordance with manufacturer's instructions. Apply epoxy primer to dry edge. Touch up with helicopter paint color, where applicable, is optional.

10. Install A912-7 pocket assembly:
 - a. With pocket hanging upside down & woven fabric facing outboard, attach pocket flap to F359-2 panel with A913-1 strip and (3) B204-2 rivets. Pocket may be pierced as required with awl.
 - b. Flip pocket up so woven fabric faces panel and temporarily secure in place with tape.
 - c. Fold pocket's aft, vertical edge inboard around one A913-6 strip and install (2) B204-2 rivets & (2) NAS1149FN632P washers (under both rivet heads) thru folded pocket & strip into panel.
 - d. Fold pocket's forward, vertical edge inboard around remaining A913-6 strip and install (2) B204-2 rivets & (2) NAS1149FN632P washers (under both rivet heads) thru folded pocket & strip, into panel.
 - e. Remove temporary tape.
 - f. Affix G682-15 "CAUTION..." decal on panel immediately above, and centered on, pocket.

Kit Instructions (continued)

11. At avionics compartment, inside lower console along with airframe wire harness, locate either
 - a. 3-socket B263-35 housing covered in black heat shrink containing wire (-2626). Remove black heat shrink. Install wire (-2578) pin of B844-3 harness assembly to open pin location 1 or 2 in B263-34 housing (provided in kit). Verify pin security. Connect newly installed B263-34 housing to existing B263-35 housing.
 - OR-
 - b. 3-socket B263-35 housing containing wire (-2626), connected to 3-pin B263-34 housing of B844-4 harness assembly. Disconnect housings; connect wire (-2578) pin of B844-3 harness assembly to open pin location 1 or 2 in B263-34 housing; verify pin security. Reconnect housings.
12. Refer to Figure 4, Detail A. Install TA202 USB port in provided location at inboard end of G703 support and secure with (2) MS35206-213 screws. Affix F654-49 "AUX PWR 5V" decal on flat surface of support above USB ports, and affix G682-14 "MAXIMUM LOAD: 10 LB (4.5 KG)" decal on tube immediately above USB ports.
13. Refer to Figure 4. Install B631-1 clamp assembly, push button pointing up, on inboard end of G703 support and secure at rivet nut (see Figure 2) using a NAS1352-08-8 screw.
14. Refer to Figure 4. Install G703 support assembly in helicopter with (4) MS27039C0806 screws, (4) NAS1149FN816P washers, and (4) MS21042L08 nuts finger tight. Tighten both outboard screws. As required to fill gap, install (3) G703-12 shims maximum between support assembly and F359 panel, use longer screws as required. Tighten both inboard screws.
15. Thru 0.5 inch diameter hole, attach B844-3 harness assembly to USB port. Attach ring terminal on wire (-2579) to a ground stud.
16. Clean up debris around avionics trays. Remove shop towel or tape. Install avionics and face on lower console and install lower console anchor screws.
17. Refer to Figure 4. Assemble RAM238U ball & (attached) B630-1 clamp assembly on G703 support with push button on forward side and pointing up. Position clamp & ball as desired and torque (2) NAS1351-3-24 screws to 40 in-lb.
18. Ensure battery switch is OFF. Access battery and connect lead-acid battery per MM § 96-11B or lithium-ion battery per MM § 96-12C as applicable.

Kit Instructions (continued)

19. Revise helicopter's Weight and Balance Record in Pilot's Operating Handbook (POH) Section 6 to reflect this installation by incorporating the following data:

Add:

Item	Weight	Long. Arm	Long. Moment	Lat. Arm	Lat. Moment
RH Accessory Support Installation (without Power Plug installation)	+0.98 lb	21.0 in.	20.58 in-lb	11.0 in.	+10.78 in-lb

AND/OR**Add:**

Item	Weight	Long. Arm	Long. Moment	Lat. Arm	Lat. Moment
LH Accessory Support Installation (without Power Plug installation)	+0.98 lb	21.0 in.	20.58 in-lb	-11.0 in.	-10.78 in-lb

20. Function check all avionics that were removed and installed.
21. Function check newly installed power connectors.
22. Make appropriate maintenance record entries.

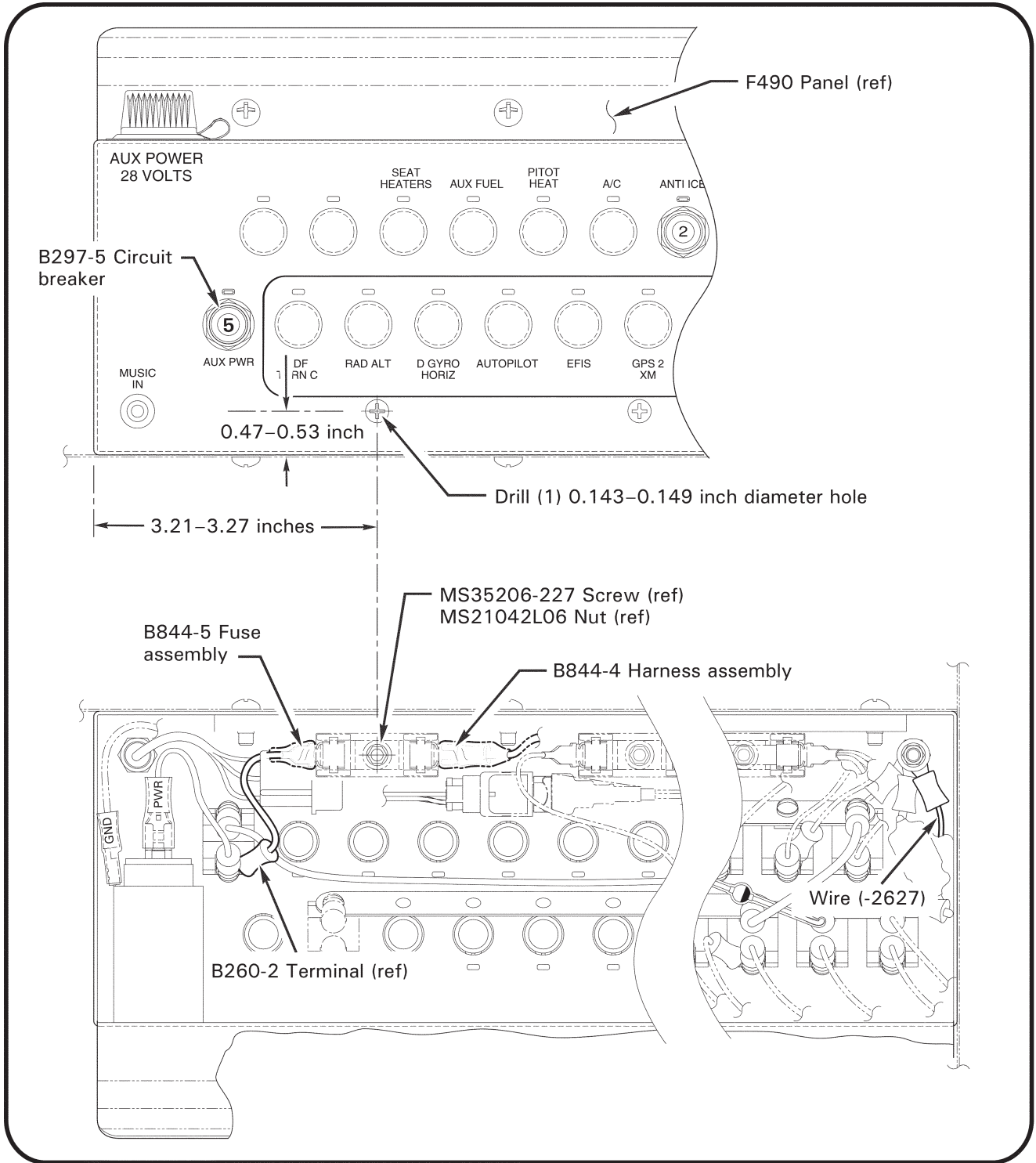

FIGURE 1 B844-5 Fuse assembly installation
(S/N 0519 & prior; typical location)

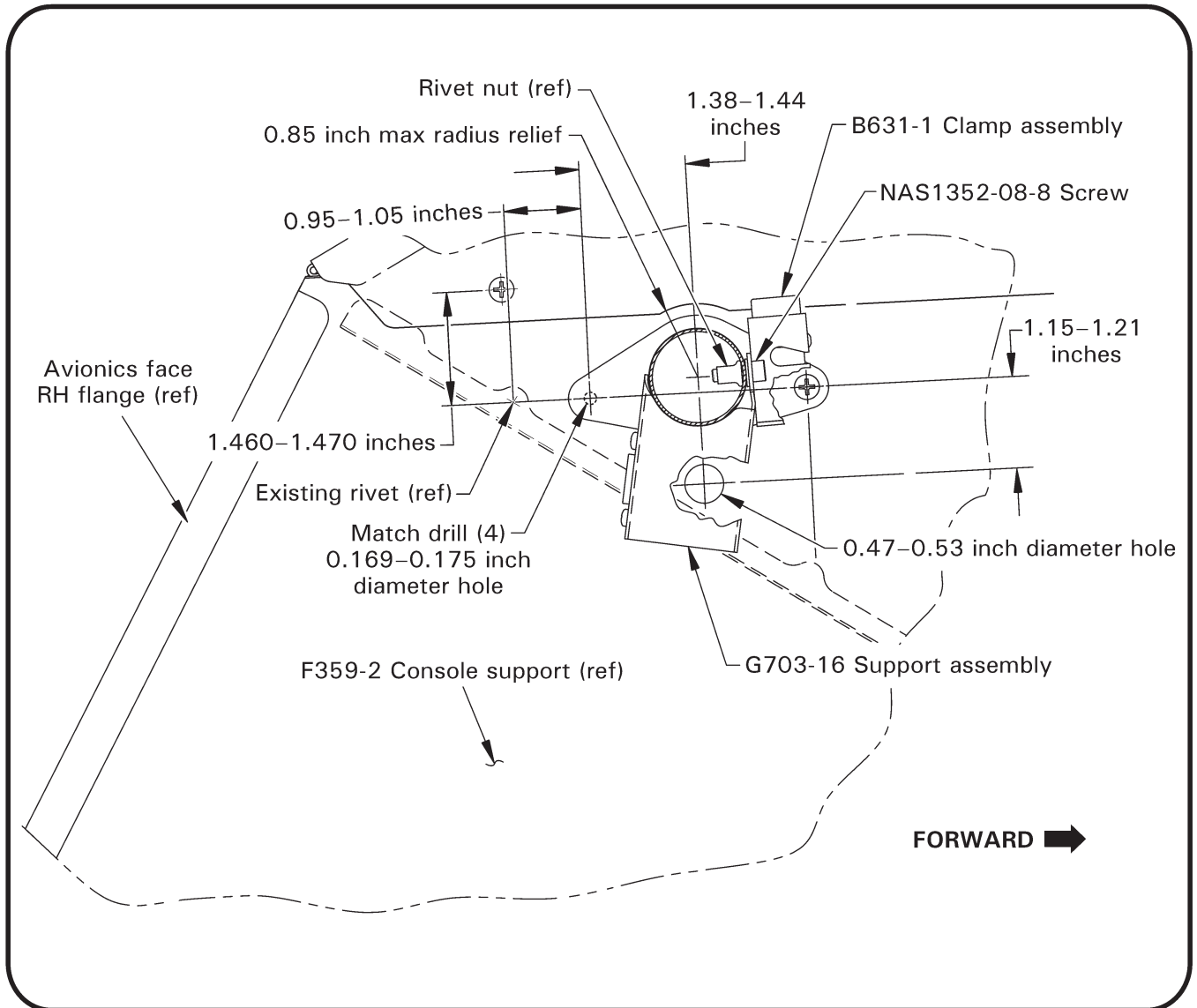

FIGURE 2 RH Support assembly installation shown
(view looking inboard; LH side similar)

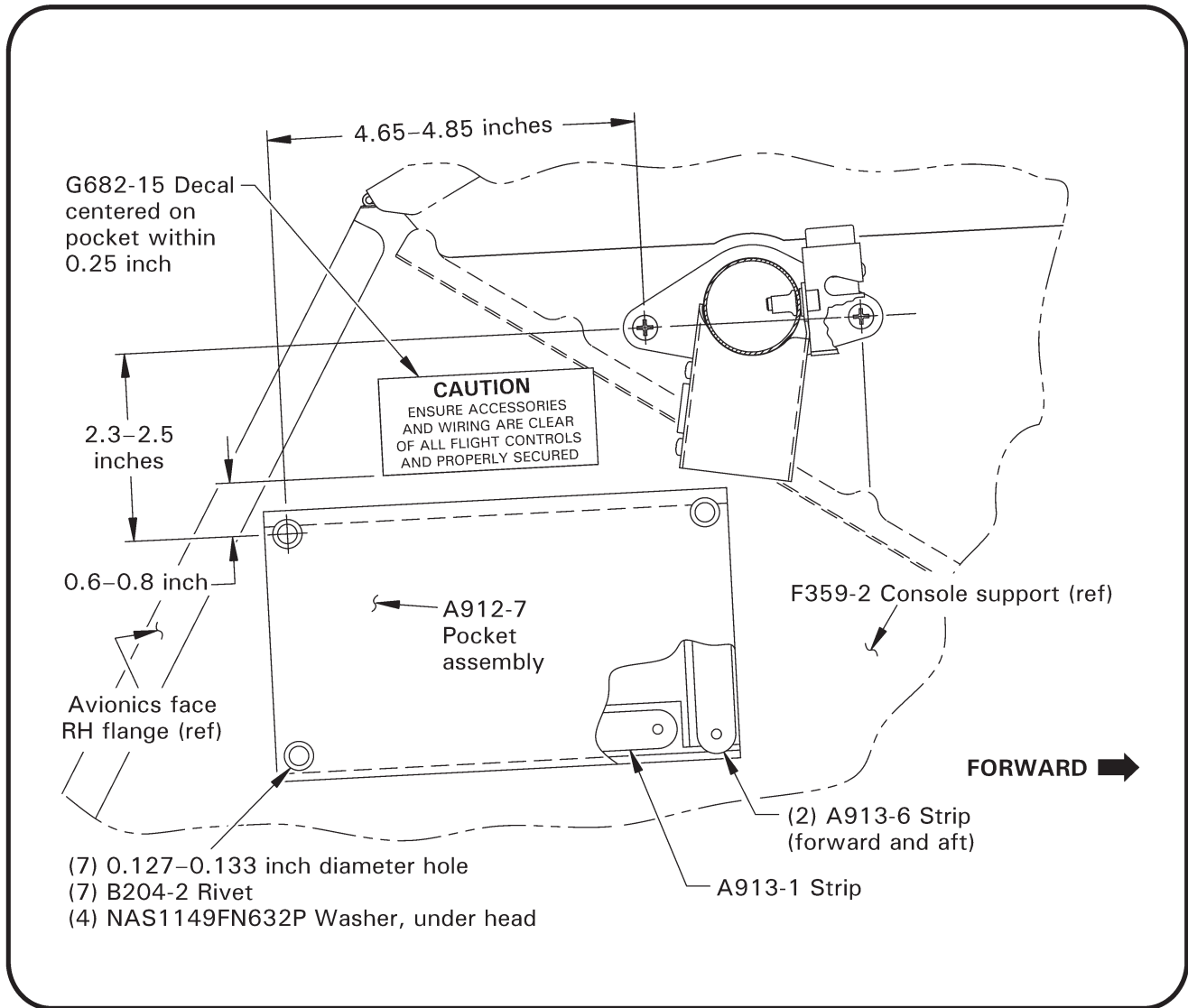

Figure 3 RH Pocket assembly installation shown
(View looking inboard; LH side similar)

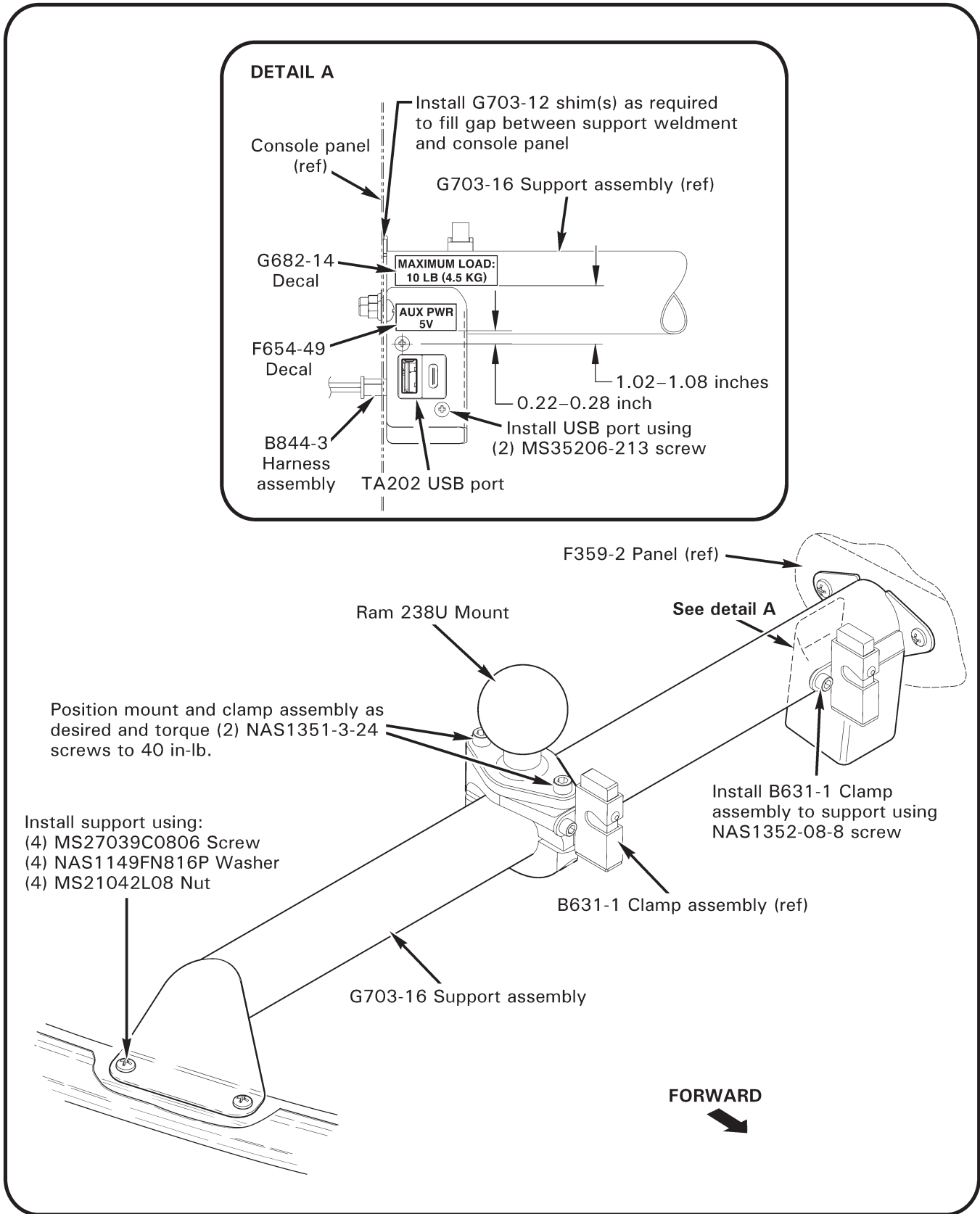

FIGURE 4 RH Completed support assembly installation
 (view looking inboard; LH side similar)