

**SECTION 9
SUPPLEMENTS**

OPTIONAL EQUIPMENT SUPPLEMENTS

Information contained in the following supplements applies only when the related equipment is installed.

CONTENTS

	Page
Fixed Floats	9-5.1
Heated Pitot	9-6.1
Police Version	9-7.1
ENG Version	9-8.1
Garmin GPSMAP 225	9-9.1
Pop-Out Floats	9-10.1
Air Conditioning	9-11.1
HeliSAS Autopilot	9-13.1
Optional Avionics	9-14.1
Lithium-Ion Battery	9-15.1

NON-U.S. SUPPLEMENTS

The following supplements contain additional information required by certain countries:

- Brazilian Supplement
- Canadian Supplement
- EASA Supplement
- FATA Supplement (Russia)
- IAC AR Supplement
- Indian Supplement
- Ukranian Supplement

INTENTIONALLY BLANK

FAA APPROVED
R44 II PILOT'S OPERATING HANDBOOK

FIXED FLOATS SUPPLEMENT

This supplement must be included in the FAA-approved Pilot's Operating Handbook when fixed-float landing gear is installed.

Information contained herein supplements or supersedes the basic manual only in those areas listed in this supplement. For limitations, procedures, and performance information not contained in this supplement, consult the basic Pilot's Operating Handbook.

APPROVED BY: _____

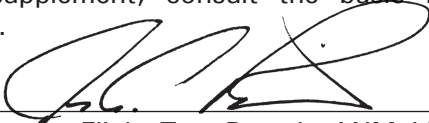
Manager, Flight Test Branch, ANM-160L
Federal Aviation Administration, LAACO
Transport Airplane Directorate

DATE: October 3, 2002

LOG OF REVISIONS

Page No.	Date
9-5.1	17 Dec 19
9-5.2	17 Dec 19
9-5.3	17 Dec 19
9-5.4	3 Oct 02
9-5.5	17 Dec 19
9-5.6	17 Dec 19
9-5.7	3 Oct 02

Page No.	Date
9-5.8	17 Dec 19
9-5.9	17 Dec 19
9-5.10	3 Oct 02
9-5.11	17 Dec 19
9-5.12	17 Dec 19
9-5.13	3 Oct 02

REVISIONS
APPROVED BY: _____

Nevada Jo Ryan

Digitally signed by Nevada Jo Ryan
Date: 2019.12.17 10:44:12 -08'00'

Manager, West Flight Test Section, AIR-716
Federal Aviation Administration
Los Angeles, CA

DATE: 17 DEC 2019

SECTION 1: GENERAL

INTRODUCTION

This supplement contains the changes and additional data applicable when fixed-float landing gear is installed.

Float landing gear is intended for safety during flights over water. Intentional (non-emergency) water landings for other than training purposes are not recommended.

NOTE

The float landing gear is approved for amphibious operation but is not certified for ditching. Some countries may prohibit certain over-water operations.

SECTION 2: LIMITATIONS

AIRSPPEED LIMITATIONS

NEVER EXCEED AIRSPEED (V_{ne}) WITH FLOATS

2200 lb TOGW & below	120 KIAS
Over 2200 lb TOGW	110 KIAS
Autorotation	100 KIAS

For V_{ne} reductions with altitude and temperature, see placards on page 9-5.3.

FLIGHT AND MANEUVER LIMITATIONS

Water landings for any reason other than an actual emergency are prohibited at weights above 2400 lb.

SECTION 2: LIMITATIONS (cont'd)

PLACARDS

In clear view and readable by the pilot in flight:

**NEVER EXCEED SPEED - KIAS
WITH FLOATS**

2200 LB TOGW & BELOW								
PRESS ALT-FT	OAT - °C							
	-30	-20	-10	0	10	20	30	40
SL								
2000		120					117	113
4000					116	112	108	104
6000			116	112	107	103	98	93
8000	116	112	107	102	97	91	86	81
10000	107	102	96	91	85	80	75	
12000	97	91	85	79	NO FLIGHT			
14000	85	79						
OVER 2200 LB TOGW, SUBTRACT 10 KIAS FOR AUTOROTATION, SUBTRACT 20 KIAS								

**NEVER EXCEED SPEED - KIAS
WITHOUT FLOATS**

2200 LB TOGW & BELOW								
PRESS ALT-FT	OAT - °C							
	-30	-20	-10	0	10	20	30	40
SL								
2000		130					127	123
4000					126	122	118	114
6000			126	122	117	113	108	103
8000	126	122	117	112	107	101	96	91
10000	117	112	106	101	95	90	85	
12000	107	101	95	89	NO FLIGHT			
14000	95	89						
OVER 2200 LB TOGW, SUBTRACT 10 KIAS FOR AUTOROTATION, SUBTRACT 30 KIAS								

SECTION 2: LIMITATIONS (cont'd)

FLOAT PRESSURE LIMITS

Minimum Float Pressure: 1.5 psig (psi gage)

Maximum Float Pressure: 5 psig

A decrease in altitude or temperature reduces float pressure. If decrease in altitude or temperature is anticipated, inflate floats per chart below to ensure 1.5 psig minimum at landing. Pressure relief valves will limit pressure for an increase in altitude or temperature.

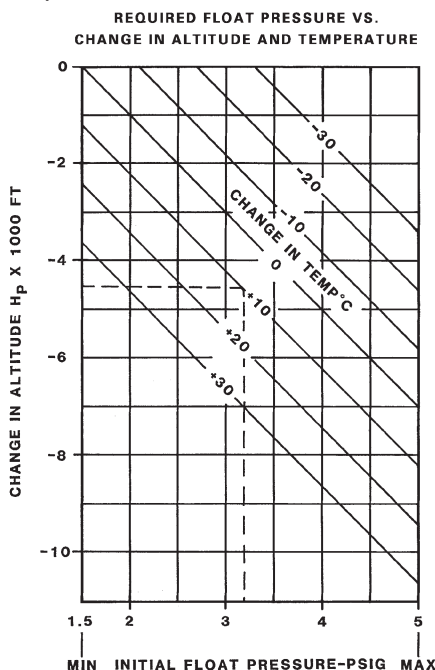

CAUTION

Failure to maintain adequate pressure can result in loss of buoyancy or in-flight instability.

EXAMPLE:

Conditions at destination:
Initial conditions:
Subtract to obtain change
in altitude and temp:

Pressure	Altitude	Temp
1000 ft	5500 ft	15°C
5500 ft		5°C
-4500 ft		+10°C

Using graph, locate -4500 ft line, read across to +10°C line, then down for minimum initial float pressure required, approximately 3.2 psig.

SECTION 3: EMERGENCY PROCEDURES

POWER FAILURE – GENERAL

CAUTION

Lowering collective rapidly or applying excessive forward cyclic while helicopter is moving forward on water can cause floats to submerge and helicopter to nose over.

POWER FAILURE ABOVE 500 FEET AGL

Autorotation to Land: Same as in basic manual.

Autorotation to Water:

1. Lower collective immediately to maintain rotor RPM.
2. Establish steady glide at approximately 70 KIAS.
3. Adjust collective to keep RPM between 97 and 108% or apply full down collective if light weight prevents attaining above 97%.
4. If altitude permits, maneuver into wind.
5. At about 40 feet AGL, begin cyclic flare.
6. At about 8 feet AGL, apply forward cyclic and raise collective just before touchdown. Touch down in slight nose high attitude with nose straight ahead.
7. Maintain cyclic in touchdown position and do not lower collective full down until forward motion has stopped.

SECTION 3: EMERGENCY PROCEDURES (cont'd)

POWER FAILURE BETWEEN 8 FEET AND 500 FEET AGL

Autorotation to Land: Same as in basic manual.

Autorotation to Water:

1. Lower collective immediately to maintain rotor RPM.
2. Adjust collective to keep RPM between 97 and 108% or apply full down collective if light weight prevents attaining above 97%.
3. If altitude permits, maneuver into wind.
4. Maintain airspeed until water is approached, then begin cyclic flare.
5. At about 8 feet AGL, apply forward cyclic and raise collective just before touchdown. Touch down in slight nose high attitude with nose straight ahead.
6. Maintain cyclic in touchdown position and do not lower collective full down until forward motion has stopped.

MAXIMUM GLIDE DISTANCE CONFIGURATION

Same as without floats, except airspeed approximately 80 KIAS.

EMERGENCY WATER LANDING – POWER OFF

See procedures for power failures.

EMERGENCY WATER LANDING – POWER ON

Make normal approach and landing to water.

SECTION 4: NORMAL PROCEDURES

DAILY OR PREFLIGHT CHECKS

15. Inflatable Floats

Float Pressure Check (See Section 2)

Float Condition Check

CAUTION

Helicopters equipped with inflated floats have an adverse roll characteristic. When sideslipping nose left or right, helicopter will tend to roll in opposite direction and could cause loss of control. To avoid adverse roll, keep helicopter trimmed with zero sideslip. Exercise extreme caution when performing simulated power failures.

CAUTION

Avoid night flight over water beyond autorotation distance to land. Height above water may be difficult to judge during a water landing.

SECTION 4: NORMAL PROCEDURES (cont'd)

OPERATION ON WATER

CAUTION

Except for actual emergencies, maximum weight for water operations is 2400 lb.

Safe operation on water has been demonstrated in waves up to 1 foot (0.3 m) (trough to crest). Maximum recommended water taxi speed is 5 knots. Some application of collective is required.

Since the helicopter sits very low on water, it is likely that water will leak into the cabin. Water landings should be limited to emergencies and training. For training, seal the removable belly panels and landing gear cross tube cover using aluminum foil tape or duct tape. Avoid salt water if possible.

There may be limited tail rotor clearance to water, particularly at aft CG. Also, even small waves may cause enough rocking to dip the tail rotor in the water. If tail rotor contact with water is suspected, have tail rotor inspected prior to further flight. (If no noticeable change in vibration occurs after suspected water contact, helicopter may be repositioned to nearest convenient inspection site.)

CAUTION

If starting or stopping rotor on water, ensure area is clear as helicopter can rotate one or more complete turns while tail rotor RPM is low.

SECTION 4: NORMAL PROCEDURES (cont'd)

PRACTICE AUTOROTATION – WITH GROUND CONTACT

Same as in basic manual. Autorotations should only be performed to a smooth, hard surface to avoid damage to floats.

PRACTICE AUTOROTATION TO WATER

Same as practice autorotation with ground contact in basic manual except touch down in slight nose high attitude with nose straight ahead. Maintain cyclic in touchdown position and do not lower collective full down until forward motion has stopped.

CAUTION

Lowering collective rapidly or applying excessive forward cyclic while helicopter is moving forward on water can cause floats to submerge and helicopter to nose over.

CAUTION

There may be limited tail rotor clearance to water, particularly at aft CG. Applying excessive aft cyclic may cause tail rotor to contact water.

SECTION 5: PERFORMANCE

NOTE: INDICATED AIRSPEED ASSUMES ZERO INSTRUMENT ERROR

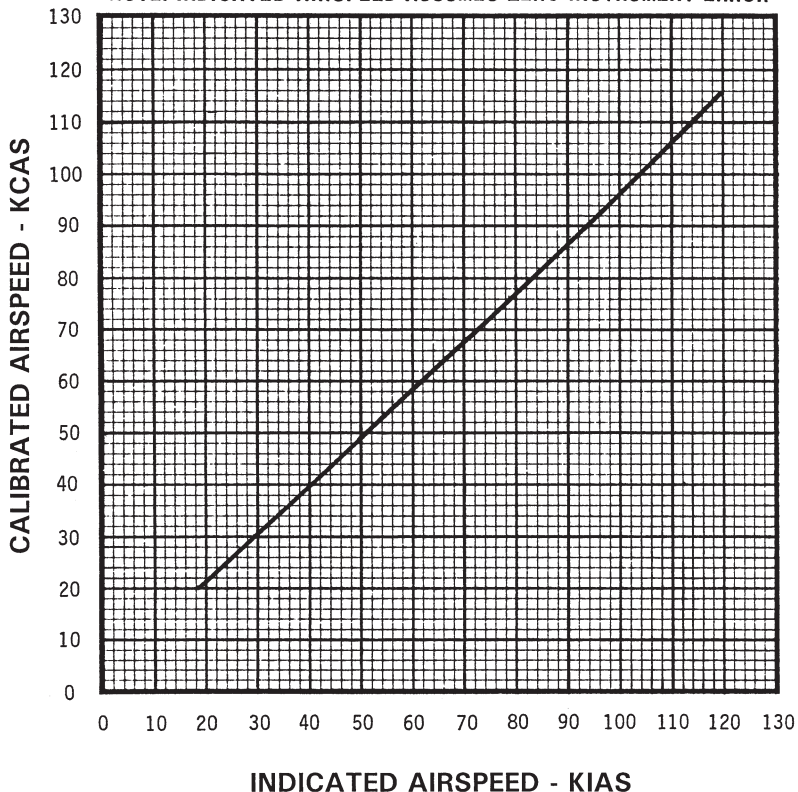

AIRSPEED CALIBRATION CURVE

R44 WITH FIXED FLOAT LANDING GEAR

SECTION 6: WEIGHT AND BALANCE

CAUTION

When changing between float and non-float configurations, weight and balance must be revised and autorotation RPM readjusted per R44 Maintenance Manual.

WEIGHT AND BALANCE RECORD

Basic empty weight and CG in float and non-float configurations is included in the Weight and Balance Summary provided with the helicopter. Modifications are to be recorded in the Weight and Balance Record.

SECTION 7: SYSTEMS DESCRIPTION

The fixed-float landing gear installation includes inflated floats, additional airframe sealing and corrosion protection, additional forward position lights in the mast fairing, longer landing gear struts, and an additional stabilizer installed at the base of the lower vertical stabilizer. Standard landing gear may be installed in place of the float landing gear per maintenance manual instructions.

| SECTION 8: HANDLING AND MAINTENANCE

GROUND HANDLING

With floats installed, special ground handling wheels are required. Refer to R44 Maintenance Manual for wheel installation and removal procedures.

FLOAT TUBES

To promote long float tube life:

1. Do not inflate floats to higher pressure than required by limitations section. Do not arbitrarily inflate floats to relief valve pressure.
2. Reduce pressure in floats if solar heating is causing excessive pressure buildup.
3. Do not allow floats to sit uninflated. Maintain some pressure to keep shape when not in use.

CAUTION

When inflating chambers individually (without a manifold), increase pressure in each chamber in increments no greater than 0.5 psig.

SECTION 10: SAFETY TIPS

Flight characteristics and handling qualities with inflated floats are more critical than with conventional landing gear. Helicopters with floats installed have an adverse roll characteristic. When sideslipping nose right or left, the helicopter will tend to roll in the opposite direction out of the turn. This could be extremely dangerous if a pilot failed to apply right pedal or put in the wrong pedal during a simulated power failure. Also, aerodynamic lift produced by floats makes both RPM and pitch control more difficult during autorotation entries. Helicopters with floats installed are also more gust sensitive and difficult to fly in turbulence.

For these reasons, it is strongly recommended that floats be removed and standard gear installed for primary flight instruction. With floats installed, pilots must keep the helicopter trimmed with zero sideslip and exercise extreme caution when performing simulated power failures.

INTENTIONALLY BLANK

FAA APPROVED
R44 II PILOT'S OPERATING HANDBOOK

HEATED PITOT SUPPLEMENT

This supplement must be included in the FAA-approved Pilot's Operating Handbook when the heated pitot is installed.

Information contained herein supplements or supersedes the basic manual only in those areas listed in this supplement. For limitations, procedures, and performance information not contained in this supplement, consult the basic Pilot's Operating Handbook.

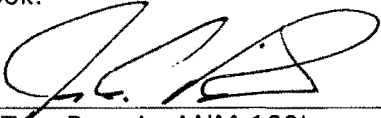
APPROVED BY: 
Manager, Flight Test Branch, ANM-160L
Federal Aviation Administration, LAACO
Transport Airplane Directorate

DATE: October 3, 2002

LOG OF PAGES

Page No.	Date	Page No.	Date
9-6.1	3 Oct 02	9-6.3	3 Oct 02
9-6.2	3 Oct 02	9-6.4	3 Oct 02

SECTION 1: GENERAL

INTRODUCTION

This supplement contains the changes and additional data applicable when the heated pitot is installed.

SECTIONS 2 and 3 No change.

SECTION 4: NORMAL PROCEDURES

USE OF PITOT HEAT

When conditions conducive to pitot ice exist, switch pitot heat on until landing or until no longer in potential icing conditions.

NOTE

The R44 is not certified for flight into known or suspected icing conditions.

NOTE

Continued use of pitot heat following an engine or alternator failure will significantly increase battery drain.

SECTION 5: PERFORMANCE

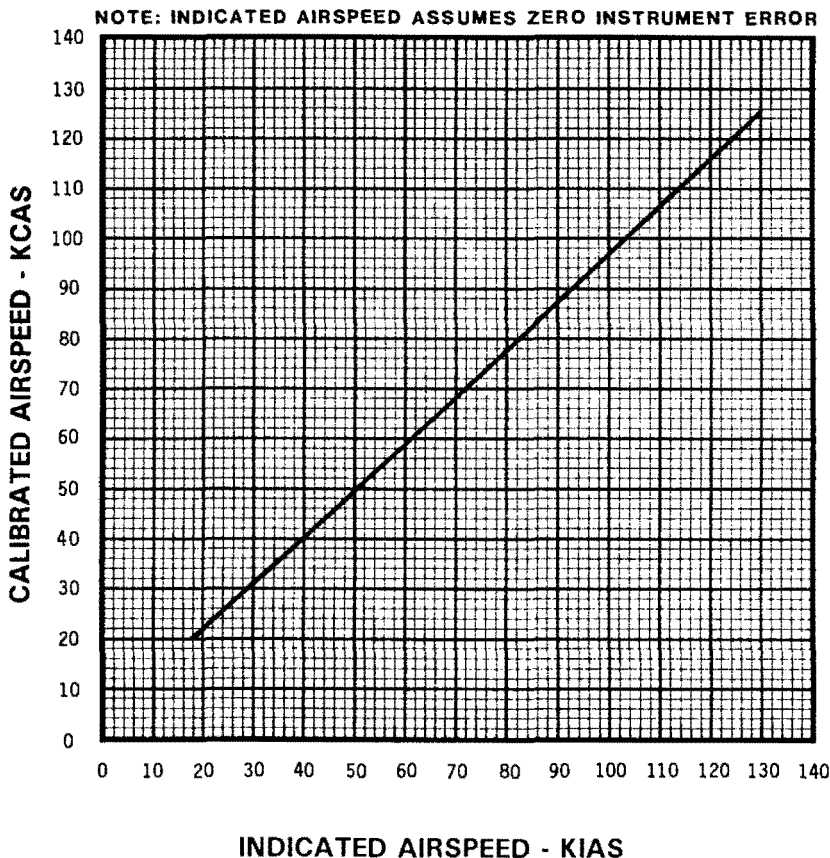

AIRSPEED CALIBRATION CURVE
HEATED PITOT INSTALLATION
VALID WITH PITOT HEAT ON OR OFF

SECTION 6: WEIGHT AND BALANCE No change.

SECTION 7: SYSTEMS DESCRIPTION

HEATED PITOT INSTALLATION

The heated pitot tube is installed in the mast fairing, replacing the standard pitot tube. Pitot heat is controlled by a toggle switch located to the right of the cyclic. Power is supplied to the heated pitot through its own 10-amp circuit breaker.

SECTION 8: HANDLING AND MAINTENANCE

CAUTION

Pitot tube becomes extremely hot with pitot heat switched on. Touching pitot tube after it has been on for more than 30 seconds can result in severe burns.

FAA APPROVED
R44 II PILOT'S OPERATING HANDBOOK

POLICE VERSION SUPPLEMENT

This supplement must be included in the FAA-approved Pilot's Operating Handbook when police equipment is installed.

Information contained herein supplements or supersedes the basic manual only in those areas listed in this supplement. For limitations, procedures, and performance information not contained in this supplement, consult the basic Pilot's Operating Handbook.

APPROVED BY:



Manager, Flight Test Branch, ANM-160L
Federal Aviation Administration, LAACO
Transport Airplane Directorate

DATE:

October 3, 2002

LOG OF REVISIONS

Page No.	Date	Page No.	Date
9-7.1	16 Apr 04	9-7.5	3 Oct 02
9-7.2	16 Apr 04	9-7.6	3 Oct 02
9-7.3	3 Oct 02	9-7.7	3 Oct 02
9-7.4	3 Oct 02	9-7.8	3 Oct 02

REVISIONS

APPROVED BY:

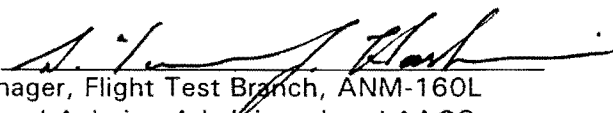

Manager, Flight Test Branch, ANM-160L
Federal Aviation Administration, LAACO
Transport Airplane Directorate

DATE:

April 16, 2004

SECTION 1: GENERAL

INTRODUCTION

This supplement contains the changes and additional data applicable to the Police Version.

The Police Version is equipped with a nose-mounted gyro-stabilized infrared camera with flat-screen LCD monitor. Available police options include a belly-mounted searchlight, FM transceivers, a video-tape recorder, a PA/siren, Lojack equipment, and a microwave transmitter. A modified left-side cyclic control allows flight from the left seat with the LCD monitor installed. Extended landing gear provides additional ground clearance for the searchlight. The battery is relocated to the tailcone to balance the weight of the infrared camera.

SECTION 2: LIMITATIONS

FLIGHT AND MANEUVER LIMITATIONS

Pilot in command must occupy right seat.

PLACARDS

Located on cover replacing right rear seat:

DO NOT OCCUPY

Located in right rear baggage compartment:

NO STOWAGE

SECTION 3: EMERGENCY PROCEDURES

POWER FAILURE ABOVE 500 FEET AGL

If time permits, retract omni antenna.

SECTION 4: NORMAL PROCEDURES

DAILY OR PREFLIGHT CHECKS

Add to item 4, Aft Cowl Door - Right Side:

Battery Relay Secure

Add to item 8, Tailcone:

Battery Secure

Delete from item 9, Cowl Door - Left Side:

Battery and Relay Secure

Add to item 11, Fuselage Left Side:

Siren Secure

Add to item 12, Nose Section:

Camera and Fairing Secure

Add to item 13, Fuselage Right Side:

Searchlight Secure

Omni Antenna Secure

NOTE

Stow searchlight horizontally when not in use to minimize chance of damage during a hard landing.

APPROACH AND LANDING

Retract omni antenna.

SECTION 5: PERFORMANCE No change.

SECTION 6: WEIGHT AND BALANCE

CAUTION

Removal of nose-mounted camera causes a large shift in CG of empty helicopter. Calculate weight and balance prior to flight with camera removed to assure aft CG limit is not exceeded.

SECTION 7: SYSTEMS DESCRIPTION

The following optional equipment may be installed:

AIRFRAME

The R44 is a three-place helicopter when police equipment is installed.

Forward cabin doors with bubble windows to enhance downward visibility replace the standard doors.

FLIGHT CONTROLS

The cyclic control has been modified to prevent interference with the LCD monitor. The left-side removable grip has been replaced with a grip on the center post.

ELECTRICAL SYSTEM

An increased-capacity alternator replaces the standard alternator to accommodate police equipment power requirements. The battery has been relocated to a battery box beneath the tailcone to balance the weight of the nose-mounted camera.

An additional circuit breaker panel on the ledge just forward of the pilot's seat contains all circuit breakers for police equipment. The outboard section of the aft row of circuit breakers is a 14-volt bus which is powered by a 28- to 14-volt converter. The police equipment master switch on the left side of the panel controls power to all police equipment.

Wiring for police equipment is in a separate harness on the right-hand keel panel outside of the control tunnel.

SECTION 7: SYSTEMS DESCRIPTION (cont'd)

INTERCOM SYSTEM

The intercom system is controlled via the audio control panel in the avionics stack. The intercom and transmit switches for the left front seat have been relocated to the floor near the observer's right heel.

SEATS, BELTS, AND BAGGAGE

The right rear seat has been replaced with a cover and cannot be occupied. Baggage is not permitted in the right rear baggage compartment due to electronic equipment and wiring in that compartment.

EXTENDED LANDING GEAR

Extended landing gear struts provide additional ground clearance for the searchlight.

INFRARED CAMERA SYSTEM

The infrared camera system consists of a gyro-stabilized, gimbal-mounted infrared/video camera in the chin and a power junction box in the right rear baggage compartment. A fairing between the camera ball and chin minimizes the aerodynamic effects of the camera. The camera is operated by the observer in the left front seat via a handheld controller.

A flat screen LCD monitor is located in front of the left front seat to display camera images. The monitor is equipped with a visor to minimize glare from the sun during daylight operation and shield the pilot from the monitor at night. The monitor mount is hinged to retract forward and down, out of the observer's way, when not in use.

SECTION 7: SYSTEMS DESCRIPTION (cont'd)

VIDEO TAPE RECORDER

The video tape recorder (VTR) is mounted on the monitor support structure and is used to record camera images. A toggle switch determines video signal routing. In the REC position, camera images can be recorded by the VTR. In the PLAY position, images being played back on the VTR can be viewed on the monitor.

SEARCHLIGHT INSTALLATION

The searchlight is installed on a motorized gimbal under the belly. The searchlight power junction box is located in the right rear baggage compartment. The searchlight is steerable in azimuth and elevation and is operated from the left front seat via a remote controller. An optional slaving system allows the searchlight to be slaved to follow the camera. The searchlight should be stowed horizontally when not in use to minimize chance of damage during a hard landing.

CAUTION

The searchlight is very bright and can disorient other pilots or ground personnel at long distances.

CAUTION

The searchlight beam is very hot. Exposure to the beam at close range for more than a few seconds can result in burns.

SECTION 7: SYSTEMS DESCRIPTION (cont'd)

PA/SIREN SYSTEM

A 100-watt speaker is located on the aft left landing gear strut. The PA system control panel is located on the instrument panel and allows the pilot or observer to select PA, radio, yelp, or siren for broadcast through the speaker.

FM TRANSCEIVERS

Four brands of FM transceiver are available on the Police Version: NAT, BK Radio, Motorola, and Technisonic.

NAT and Motorola FM transceivers are mounted in the right rear baggage compartment. A control head located beneath the monitor is used to control tuning and individual radio functions.

BK Radio and Technisonic dual-band FM transceivers are mounted beneath the fold down monitor and incorporate controls on their faceplates.

The FM transceivers are selectable from the audio control panel in the avionics stack.

INTERIOR LIGHT

An additional observer-side interior light is operated via a momentary foot switch on the left-hand forward floor. Power is supplied to the interior light via the "GAGES" breaker in the left hand circuit breaker panel and is not disconnected by the police equipment master switch.

LOJACK

The Lojack installation consists of a receiver in the right rear baggage compartment, a display and control unit on the right side of the instrument console, and four belly-mounted stub antennas. Lojack is used to track stolen vehicles equipped with Lojack transmitters.

SECTION 7: SYSTEMS DESCRIPTION (cont'd)

MICROWAVE SYSTEM

The microwave transmitting system consists of the microwave transmitter in the right rear baggage compartment, a retractable omnidirectional microwave antenna on the right skid tube, and an optional belly-mounted downlook antenna. If both antennas are installed, a switch forward of the right rear baggage compartment selects which antenna is active. The transmitter is operated via a controller in the rear-center console. The skid-mounted antenna is stowed parallel to the skid tube and rotated down to the vertical position for transmitting. It is actuated by an electric motor with the control switch located on the rear-center console. The antenna is designed to break away without damaging the helicopter if inadvertently left extended during landing. However, damage to the antenna or actuation mechanism may occur.

CAUTION

Do not kick or step on antenna. Ensure antenna is retracted before landing.

SECTION 8: HANDLING AND MAINTENANCE

BATTERY

The battery is located in a box beneath the tailcone. For battery charging, access to battery relay terminal A1 (labeled + 24V) and a grounded tab (labeled -) is provided inside the aft cowl door.

FAA APPROVED
R44 II PILOT'S OPERATING HANDBOOK

E.N.G. VERSION SUPPLEMENT

This supplement must be included in the FAA-approved Pilot's Operating Handbook when Electronic News Gathering (ENG) equipment is installed.

Information contained herein supplements or supersedes the basic manual only in those areas listed in this supplement. For limitations, procedures, and performance information not contained in this supplement, consult the basic Pilot's Operating Handbook.

APPROVED BY:



Manager, Flight Test Branch, ANM-160L
Federal Aviation Administration, LAACO
Transport Airplane Directorate

DATE: October 3, 2002

LOG OF REVISIONS

Page No.	Date	Page No.	Date
9-8.1	13 May 09	9-8.8	14 Mar 08
9-8.2	31 Jan 03	9-8.9	14 Mar 08
9-8.3	31 Jan 03	9-8.10	14 Mar 08
9-8.4	31 Jan 03	9-8.11	14 Mar 08
9-8.5	14 Mar 08	9-8.12	14 Mar 08
9-8.6	13 May 09	9-8.13	14 Mar 08
9-8.7	31 Jan 03		

REVISIONS

APPROVED BY:

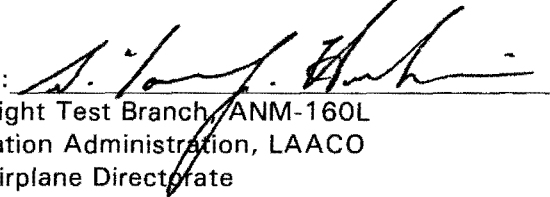

Manager, Flight Test Branch, ANM-160L
Federal Aviation Administration, LAACO
Transport Airplane Directorate

DATE: May 13, 2009

SECTION 1: GENERAL

INTRODUCTION

This supplement contains the changes and additional data applicable when Electronic News Gathering (ENG) equipment is installed.

The ENG version is equipped with a nose-mounted, gyro-stabilized video camera and two rear seat equipment panels which house various audio and video controls. The battery is relocated to the tailcone to balance the weight of the nose camera and the right rear seat is not installed to allow equipment installation in that area. ENG equipment options are described in section 7.

SECTION 2: LIMITATIONS

WEIGHT LIMITS

Maximum in left front seat 250 lb (113 kg)

PLACARDS

Located under left front seat and in right rear equipment compartment:

NO STOWAGE

Located on laptop camera controller and on video titler keyboard:

STOW DURING TAXI,
TAKEOFF, AND LANDING

SECTION 3: EMERGENCY PROCEDURES

POWER FAILURE ABOVE 500 FEET AGL

If time permits, stow laptop controller and video titler keyboard, and retract omni antenna.

SECTION 4: NORMAL PROCEDURES

DAILY OR PREFLIGHT CHECKS

Add to item 4, Aft Cowl Door - Right Side:
Battery Relay Secure

Add to item 8, Tailcone:
Battery Secure

Delete from item 9, Cowl Door - Left Side:
Battery and Relay Secure

Add to item 12, Nose Section:
Camera and Fairing Secure

Add to item 13, Fuselage Right Side:
Omni Antenna Secure

TAKEOFF PROCEDURE

Stow laptop camera controller and video titler keyboard during taxi and takeoff.

APPROACH AND LANDING

Stow laptop controller and video titler keyboard, and retract omni antenna.

SECTION 5: PERFORMANCE No change.

SECTION 6: WEIGHT AND BALANCE

CAUTION

Removal of nose-mounted camera causes a large shift in CG of empty helicopter. Calculate weight and balance prior to flight with camera removed to assure aft CG limit is not exceeded.

SECTION 7: SYSTEMS DESCRIPTION

AIRFRAME

The R44 is a three-place helicopter when ENG equipment is installed.

ELECTRICAL SYSTEM

The battery has been relocated to a battery box beneath the tailcone to balance the weight of the nose-mounted camera.

An additional circuit breaker panel on the ledge just forward of the pilot's seat contains all circuit breakers for ENG equipment. The forward row of circuit breakers is a 28-volt bus and the aft row is a 14-volt bus. A 28-to 14-volt converter powers the 14-volt bus. The news equipment master switch on the left side of the panel controls power to all ENG equipment.

Various combinations of the following optional equipment may be installed.

SECTION 7: SYSTEMS DESCRIPTION (cont'd)

NOSE-MOUNTED CAMERA SYSTEM

The nose-mounted camera system consists of a gyro-stabilized, gimbal-mounted video camera in the chin and a power junction box in the right rear equipment compartment. A fairing between the camera ball and chin minimizes the aerodynamic effects of the camera. The camera is operated from the left rear seat via a laptop controller.

When not in use, the laptop controller may be stowed and secured either with the supplied bungee cord in the stowage tray that replaces the right rear seat, or with the supplied velcro strap in the stowage tray behind the pilot's seat.

CAUTION

The laptop controller is heavy and can cause injury if not secured during a hard landing. Always secure controller during taxi, takeoff, and landing operations.

SECTION 7: SYSTEMS DESCRIPTION (cont'd)

AUDIO AND INTERCOM SYSTEM

The audio system consists of four audio control panels and an audio junction box. The audio junction box is located beneath the left front seat. Power is supplied via a 5-amp circuit breaker in the left hand circuit breaker panel. Power to the audio system is not disconnected by the news equipment master switch.

The pilot's audio panel is located in the console. Push buttons are used to select a primary (transmit and monitor) audio component. Green LEDs indicate which audio component is currently selected as primary. Additional components may be monitored by selecting their toggle switches up. Sliders control volume level for each component being monitored.

Intercom control is at the far right of the audio panel. Toggle switch down isolates the pilot from the intercom system, toggle switch up selects normal keyed intercom mode, and button depressed is hot-mic mode.

The first detent of the pilot's trigger switch is the intercom key. The second detent transmits on Com 1. The thumb button transmits on the panel-selected audio component.

A toggle switch to the right of the OAT gage may be used to bypass the audio system and connect the pilot directly to Com 1. This mode is automatically engaged in the event of an audio system power failure. (The transmit indicator on Com 1's display can be used to verify transmission.)

The left front seat audio panel operates in the same manner as the pilot's audio panel but is not connected to the bypass toggle switch. The first detent of the co-pilot's trigger switch is the intercom key, and the second detent transmits on the panel-selected audio component. A handheld transmit switch has been added for use when the left cyclic grip is removed. A lockout feature mutes the audio from a Com radio when a transmission is made on the other Com radio.

SECTION 7: SYSTEMS DESCRIPTION (cont'd)

AUDIO AND INTERCOM SYSTEM (cont'd)

The rear seat audio panel is connected to the rear seat headset jack. There is no voice-activated intercom mode for the rear seat. The rear seat intercom switch has been relocated to the outboard side of the seat box. In addition, the laptop camera controller contains intercom and transmit switches for the camera operator.

The microwave audio panel controls which signals are sent to the microwave transmitter. Selecting the toggle switch up for a component sends its signal to the transmitter. Push buttons are not functional on this panel.

FORWARD MONITOR INSTALLATION

The forward monitor installation consists of two small color LCD monitors mounted side by side on top of the instrument panel. The right monitor displays nose camera, micro-camera, or video tape recorder images as selected by the video switcher. The left monitor displays TV broadcasts as selected by the TV tuner.

SECTION 7: SYSTEMS DESCRIPTION (cont'd)

AFT MONITOR INSTALLATION

The aft monitor installation consists of two color LCD monitors mounted to the cross tube between the front seatbacks. Position and angle of the monitors is adjustable via friction swivel mounts.

The small, right-hand monitor displays TV broadcasts as selected by the TV tuner or VTR playback. The large, left-hand monitor may be switched between three input signals. Input A displays nose camera, micro camera, or video tape recorder images as selected by the video switcher. Input B bypasses the video switcher and displays nose-camera images directly. The YPrPb input bypasses the video switcher and displays annotated nose-camera images.

VIDEO SWITCHER

The video switcher is located in the center rear equipment panel and is used to select the video signal source (nose camera, video recorder playback, microwave receiver, or micro cameras). The signal is then routed to the monitors, microwave transmitter, and video tape recorder.

TV TUNER

The TV tuner is mounted in the right rear equipment panel and is used to select television broadcasts to be displayed on the monitors.

MICRO CAMERA SYSTEM

The micro camera system consists of up to three small cameras which may be mounted at the tip of the horizontal stabilizer, on the windshield bow, on the cabin interior right side, or on the aft cabin wall; and their control units which are in the right rear equipment panel. The horizontal stabilizer camera is enclosed in a weather-proof case.

SECTION 7: SYSTEMS DESCRIPTION (cont'd)

VIDEO TAPE RECORDER

The video tape recorder is located either in the right rear equipment compartment or on the right rear equipment rails or tray, and is controlled either by a remote control mounted on the center rear equipment panel or by the controls on its face. It is secured using one of the methods shown below.

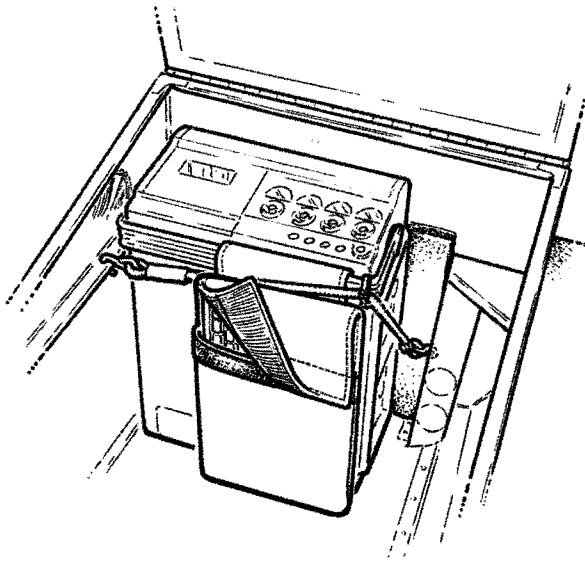

Equipment compartment VTR installation: Secured by elastic cord as shown.

SECTION 7: SYSTEMS DESCRIPTION (cont'd)

VIDEO TAPE RECORDER (cont'd)

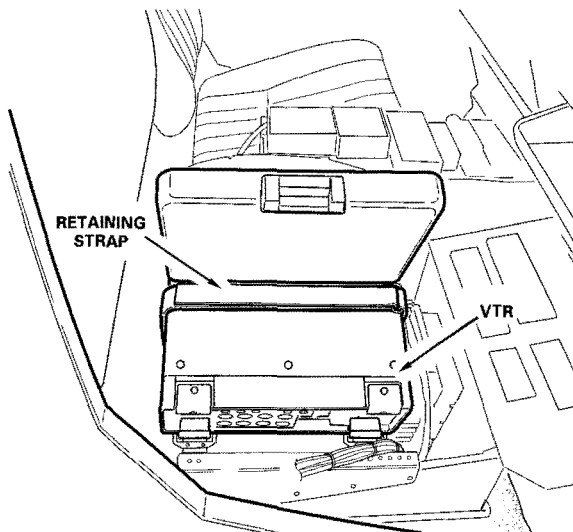

Equipment rails installation: Secured by velcro strap as shown.

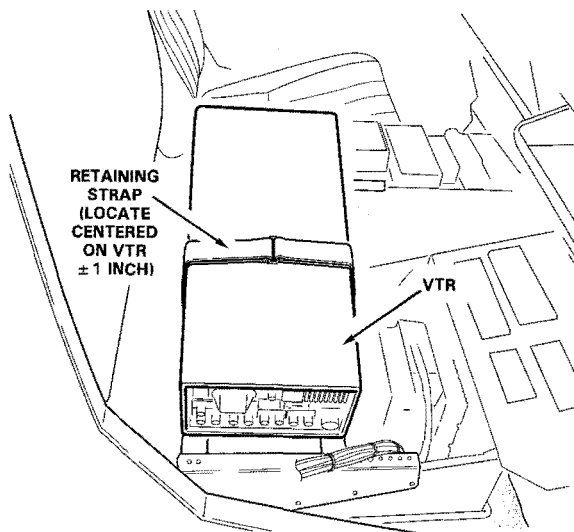

Alternate equipment rails installation: Secured by velcro strap as shown.

SECTION 7: SYSTEMS DESCRIPTION (cont'd)

VIDEO TITLER

The video titler consists of the processor located in the right rear equipment compartment and a laptop keyboard. The keyboard is used to add captions to the nose-mounted camera video signal. In addition, the processor is connected to the helicopter's GPS receiver, allowing GPS coordinates to be displayed. Selecting "AUX" on the video switcher adds the titler signal to the nose-mounted camera signal.

When not in use, stow keyboard in the pouch as shown in the equipment compartment VTR installation illustration on page 9-8.9, or in a pouch on the aft cabin wall.

MICROWAVE SYSTEM

Two microwave transmitting systems are available on the ENG version.

The omnidirectional microwave transmitting system consists of the microwave transmitter in the right rear equipment compartment and a retractable omnidirectional microwave antenna on the right skid tube. The transmitter is operated via a controller in the center rear equipment panel. The antenna is stowed parallel to the skid tube and rotated down to the vertical position for transmitting. It is actuated by an electric motor with the control switch located on the center rear panel. The antenna is designed to break away without damaging the helicopter if inadvertently left extended during landing. However, damage to the antenna or actuation mechanism may occur.

CAUTION

Do not kick or step on antenna. Ensure antenna is retracted before landing.

SECTION 7: SYSTEMS DESCRIPTION (cont'd)

MICROWAVE SYSTEM (cont'd)

The directional microwave transmitting system uses the same transmitter and transmitter controller as the omnidirectional system. The directional antenna is contained in a pod under the belly. The directional antenna pod contains a GPS tracking system which keeps the antenna aimed at a ground-based receive site. The antenna controller is located in the center rear equipment panel.

Either or both types of transmitting system may be installed. If both types are installed, a switch on the center rear equipment panel controls which antenna is active.

The transmitting system may be combined with an optional microwave receiver which is located in the right rear equipment panel. Controls are located on the receiver face.

FM TRANSCEIVERS

FM transceiver #1 is mounted forward and below the left circuit breaker panel, and FM transceiver #2 is mounted in the center rear equipment panel. Either transceiver is selectable from any of the three main audio control panels.

AM/FM RECEIVERS

AM/FM receiver #1 is mounted adjacent to FM transceiver #1, and AM/FM receiver #2 is mounted in the right rear equipment panel. Either receiver is selectable from any of the three main audio control panels.

SCANNER

A multi-band scanner may be installed in place of AM/FM receiver #2 and is selectable from any of the three main audio control panels.

SECTION 7: SYSTEMS DESCRIPTION (cont'd)

INTERIOR LIGHT

An additional interior light installed to the right of the rear headset hangers illuminates the rear equipment panels and the camera operator's laptop controller. Power is supplied to the interior light via the "GAGES" circuit breaker in the left hand circuit breaker panel and is not disconnected by the news equipment master switch. The light is controlled by a switch on its face plate.

TALENT LIGHT

The forward talent light is mounted on the left side of the instrument console and is used to illuminate the reporter during broadcasts in low-light conditions. Beam elevation is adjustable via a friction mount. The aft talent light is mounted at the top of the right door post and is used to illuminate the camera operator. Both lights are controlled by toggle switches on the center rear equipment panel.

CAUTION

Talent lights may cause glare for pilot at night. Switch lights off if glare is objectionable.

SEATS, BELTS, AND BAGGAGE

Baggage is not permitted under the left front seat or in the right rear equipment compartment due to electronic equipment and wiring in these areas.

SECTION 8: HANDLING AND MAINTENANCE

BATTERY

The battery is located in a box beneath the tailcone. For battery charging, access to battery relay terminal A1 (labeled + 24V) and a grounded tab (labeled -) is provided inside the aft cowl door.

INTENTIONALLY BLANK

FAA APPROVED
R44 II PILOT'S OPERATING HANDBOOK

GARMIN GPSMAP 225 SUPPLEMENT

This supplement must be included in the FAA-approved Pilot's Operating Handbook when the Garmin GPSMAP 225 is installed.

Information contained herein supplements or supersedes the basic manual only in those areas listed in this supplement. For limitations, procedures, and performance information not contained in this supplement, consult the basic Pilot's Operating Handbook.

APPROVED BY: 

Manager, Flight Test Branch, ANM-160L
Federal Aviation Administration, LAACO
Transport Airplane Directorate

DATE: October 3, 2002

LOG OF PAGES

Page No.	Date
9-9.1	3 Oct 02
9-9.2	3 Oct 02

SECTION 1: GENERAL

Refer to Owner's Manual for use of the Garmin GPSMAP 225.

SECTIONS 2 and 3 No change.

SECTION 4: NORMAL PROCEDURES

DAILY OR PREFLIGHT CHECKS

CAUTION

Dimmer may not dim display sufficiently for night flight. To further reduce brightness, increase contrast setting using Auxiliary menu and System Setup submenu. (Refer to Owner's Manual.)

SECTIONS 5 thru 8 No change.

FAA APPROVED
R44 II PILOT'S OPERATING HANDBOOK

POP-OUT FLOATS SUPPLEMENT

This supplement must be included in the FAA-approved Pilot's Operating Handbook when pop-out floats are installed.

Information contained herein supplements or supersedes the basic manual only in those areas listed in this supplement. For limitations, procedures, and performance information not contained in this supplement, consult the basic Pilot's Operating Handbook.

APPROVED BY: _____

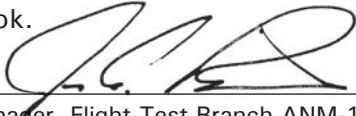
Manager, Flight Test Branch ANM-160L
Federal Aviation Administration
Los Angeles Aircraft Certification Office,
Transport Airplane Directorate

DATE: October 3, 2002

LOG OF REVISIONS

Page No.	Date	Page No.	Date
9-10.1	18 Dec 2015	9-10.8	18 Dec 2015
9-10.2*	18 Dec 2015	9-10.9	18 Dec 2015
9-10.3	18 Dec 2015	9-10.10	18 Dec 2015
9-10.4	18 Dec 2015	9-10.11*	18 Dec 2015
9-10.5	18 Dec 2015	9-10.12*	18 Dec 2015
9-10.6	18 Dec 2015	9-10.13*	18 Dec 2015
9-10.7	18 Dec 2015	9-10.14*	18 Dec 2015

* Manufacturer's data, not FAA approved.

REVISIONS

APPROVED BY: _____

Manager, Flight Test Branch ANM-160L
Federal Aviation Administration
Los Angeles Aircraft Certification Office,
Transport Airplane Directorate

DATE: December 18, 2015

SECTION 1: GENERAL

INTRODUCTION

This supplement contains the changes and additional data applicable when pop-out floats are installed.

Pop-out floats are intended for safety during over-water flights. Intentional water landings for other than training purposes are not recommended.

NOTE

The pop-out floats are not certified for ditching. Some countries may prohibit certain over-water operations.

SECTION 2: LIMITATIONS

AIRSPEED LIMITS

ADDITIONAL AIRSPEED LIMITS

100 KIAS maximum at power above MCP.

With floats stowed, 100 KIAS maximum with any combination of cabin doors removed.

80 KIAS maximum for float inflation.

80 KIAS maximum with floats inflated.

115 KIAS maximum with float system armed (safety catch in READY position).

WEIGHT LIMITS

Maximum weight
for intentional water operations 2400 lb (1091 kg)

FLIGHT AND MANEUVER LIMITATIONS

Maximum altitude decrease with floats inflated is 4000 feet.

CAUTION

Altitude loss greater than 4000 feet may cause floats to lose shape and rigidity due to atmospheric pressure increase. Do not inflate floats above 4000 feet AGL.

Water landings for any reason other than an actual emergency are prohibited at weights above 2400 lb (1091 kg).

PLACARDS

Near inflation lever:

V_{ne} WITH FLOATS INFLATED: 80 KIAS

SECTION 3: EMERGENCY PROCEDURES

POWER FAILURE – GENERAL

CAUTION

Lowering collective rapidly or applying excessive forward cyclic while helicopter is moving forward on water can cause floats to submerge and helicopter to nose over.

CAUTION

Float inflation may take up to three seconds. Squeeze inflation lever early enough to allow full inflation before water contact.

POWER FAILURE ABOVE 500 FEET AGL

Autorotation to land: Same as in basic manual.

Autorotation to water:

1. Lower collective immediately to maintain rotor RPM.
2. Reduce airspeed to below 80 KIAS.
3. Adjust collective to keep RPM between 97 and 108% or apply full down collective if light weight prevents attaining above 97%.
4. If altitude permits, maneuver into wind.
5. Inflate floats.

CAUTION

Do not inflate floats above 80 KIAS. Do not exceed 80 KIAS with floats inflated.

6. At about 40 feet AGL, begin cyclic flare.
7. At about 8 feet AGL, apply forward cyclic and raise collective just before touchdown. Touch down in slight nose high attitude with nose straight ahead.
8. Maintain cyclic in touchdown position and do not lower collective full down until forward motion has stopped.

SECTION 3: EMERGENCY PROCEDURES (cont'd)

POWER FAILURE BETWEEN 8 FEET AND 500 FEET AGL

Autorotation to land: Same as in basic manual.

Autorotation to water:

1. Lower collective immediately to maintain rotor RPM.
2. Reduce airspeed to below 80 KIAS.
3. Adjust collective to keep RPM between 97 and 108% or apply full down collective if light weight prevents attaining above 97%.
4. If altitude permits, maneuver into wind.
5. Inflate floats.

CAUTION

Do not inflate floats above 80 KIAS.
Do not exceed 80 KIAS with floats inflated.

6. Maintain airspeed until water is approached, then begin cyclic flare.
7. At about 8 feet AGL, apply forward cyclic and raise collective just before touchdown. Touch down in slight nose high attitude with nose straight ahead.
8. Maintain cyclic in touchdown position and do not lower collective full down until forward motion has stopped.

SECTION 3: EMERGENCY PROCEDURES (cont'd)

POWER FAILURE BELOW 8 FEET AGL

Over land: Same as in basic manual.

Over water:

1. Apply right pedal as required to prevent yawing.
2. Inflate floats.
3. Allow rotorcraft to settle.
4. Raise collective just before touchdown.

MAXIMUM GLIDE DISTANCE CONFIGURATION

Same as in basic manual except airspeed 80 KIAS with floats inflated.

EMERGENCY WATER LANDING – POWER OFF

See procedures for power failures in this supplement.

EMERGENCY WATER LANDING – POWER ON

1. Reduce airspeed to below 80 KIAS.
2. Inflate floats.

CAUTION

Do not inflate floats above 80 KIAS.
Do not exceed 80 KIAS with floats inflated.

3. Make normal approach and landing to water.

SECTION 4: NORMAL PROCEDURES

DAILY OR PREFLIGHT CHECKS

15. Pop-Out Floats

Float and float cover condition Check
Hose and fitting condition Check
Pressure cylinder Check pressure
Safety pin at pressure cylinder Verify removed
Inflation lever safety "Ready" or "Locked"
as required

CAUTION

Avoid night flight over water beyond autorotation distance to land. Height above water may be difficult to judge during a water landing.

NOTE

When OAT is below -10°C, there may be insufficient charge in pressure cylinder for full inflation.

FLOAT INFLATION

The red inflation lever located under the pilot's collective is equipped with a safety catch to prevent inadvertent float inflation. Prior to overwater flight, place the safety catch in the READY position. With the safety catch in the READY position, floats may be inflated by squeezing inflation lever.

Over land, safety catch should be reset to LOCKED position.

CAUTION

Observe 115 KIAS speed limitation when safety catch is in READY position.

SECTION 4: NORMAL PROCEDURES (cont'd)

FLOAT INFLATION (cont'd)

CAUTION

The pressure cylinder also has provisions for a safety pin at the valve on the cylinder neck. This safety pin is for use during maintenance and cylinder transport only and must be removed at all other times.

NOTE

Some flapping of float covers during flight with floats inflated is normal. To minimize wear, consider removing covers if an extended flight with inflated floats is required.

SECTION 4: NORMAL PROCEDURES (cont'd)

OPERATION ON WATER

Safe operation on water has been demonstrated in waves up to 1 foot (0.3 m) (trough to crest). Maximum recommended water taxi speed is 5 knots. Some application of collective is required.

Since the helicopter sits very low on water, it is likely that water will leak into the cabin. Intentional water landings should be limited to training. For training, seal the removable belly panels and landing gear cross tube cover using aluminum foil tape or duct tape. Avoid salt water if possible.

There may be limited tail rotor clearance to water, particularly at aft CG. Also, even small waves may cause enough rocking to dip the tail rotor in the water. If tail rotor contact with water is suspected, have tail rotor inspected prior to further flight. (If no noticeable change in vibration occurs after suspected water contact, helicopter may be repositioned to nearest convenient inspection site.)

CAUTION

Except for actual emergencies, maximum weight for water operation is 2400 lb (1091 kg).

CAUTION

If starting or stopping rotor on water, ensure area is clear as helicopter can rotate one or more complete turns while tail rotor RPM is low.

SECTION 4: NORMAL PROCEDURES (cont'd)

PRACTICE AUTOROTATION – WITH GROUND CONTACT

Same as in basic manual. Autorotations with floats stowed should only be performed to a smooth, hard surface to avoid damage to floats. Touch-down autorotations with floats inflated are not recommended due to the possibility of damage to floats.

PRACTICE AUTOROTATION TO WATER

Autorotation to water with floats inflated is same as practice autorotation with ground contact in basic manual except touch down in slight nose high attitude with nose straight ahead. Maintain cyclic in touchdown position and do not lower collective full down until forward motion has stopped.

CAUTION

Lowering collective rapidly or applying excessive forward cyclic while helicopter is moving forward on water can cause floats to submerge and helicopter to nose over.

CAUTION

There may be limited tail rotor clearance to water, particularly at aft CG. Applying excessive aft cyclic may cause tail rotor to contact water.

SHUTDOWN PROCEDURE

Add:

Inflation lever safety LOCKED

SECTION 5: PERFORMANCE

No change.

SECTION 6: WEIGHT AND BALANCE

WEIGHT AND BALANCE RECORD

Basic empty weight and CG with pop-out float landing gear and pressure cylinder installed are included in the Weight and Balance Summary provided with the helicopter. If pressure cylinder is removed, update Weight and Balance Record. A charged pressure cylinder weighs 11.4 lb. The longitudinal arm of the cylinder is 41.2 inches from datum and the lateral arm is -8.5 inches from datum.

SECTION 7: SYSTEMS DESCRIPTION

The pop-out float system consists of inflatable floats stowed in protective covers along the skid tubes, a pressure cylinder located in the compartment under the left front seat, flexible hoses from the cylinder to the floats, an inflation lever located on the pilot's collective, and an additional stabilizer installed at the base of the lower vertical stabilizer.

The pressure cylinder is of aluminum construction reinforced with carbon filament windings and is charged with helium. Proper pressure is indicated on a placard on the cylinder, and pressure can be checked using the gage on the cylinder valve.

A safety catch on the inflation lever can be set to prevent inadvertent actuation. With the safety catch in the READY position, floats are inflated by squeezing firmly on the inflation lever. (Approximately 20 lb force is required.) Float inflation time is approximately 2-3 seconds. With the safety catch in the LOCKED position, the inflation lever is locked out.

To operate the safety catch, push spring-loaded knob with thumb while rotating U-shaped pin with forefinger as shown in figure.

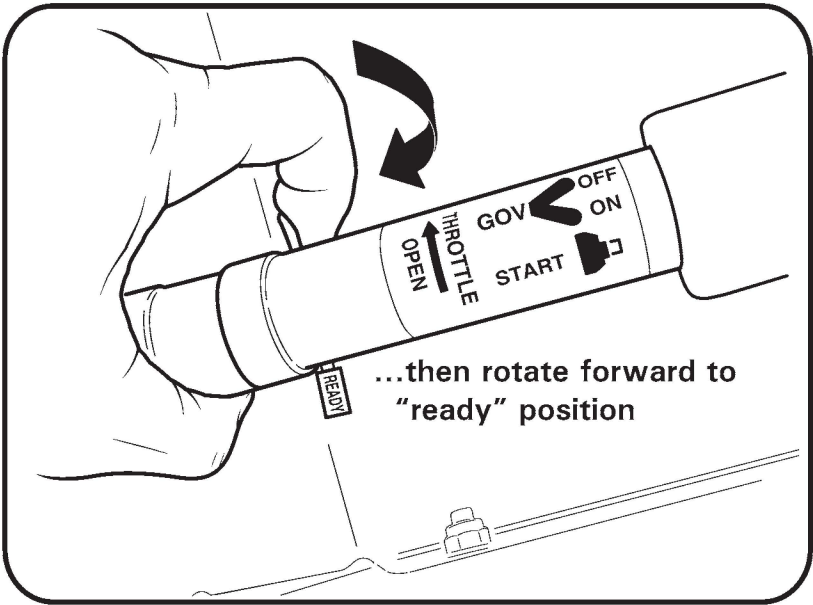
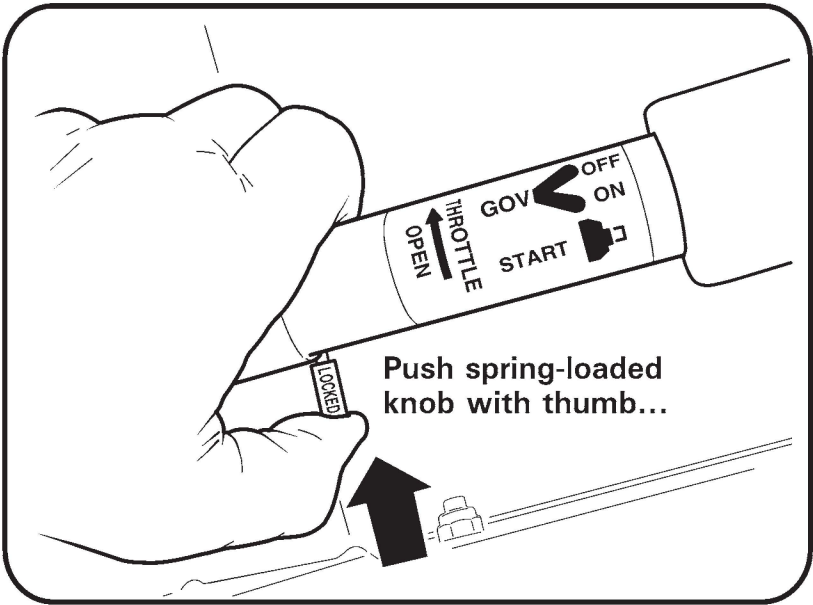

SECTION 7: SYSTEMS DESCRIPTION (cont'd)

The pop-out floats are approved for amphibious operation but are not certified for ditching. They are intended for enhanced safety during over-water flights. Intentional water landings for other than training purposes are not recommended.

NOTE

Floats maintain full pressure for at least 1 hour after inflation and typically maintain shape for several hours. Monitor float inflation state if helicopter is parked on water for an extended period.

SECTION 8: HANDLING AND MAINTENANCE

GROUND HANDLING

With floats installed, special ground handling wheels (Robinson part number MT980-1 and MT980-2) are required.

A safety pin is provided for installation at the pressure cylinder valve. This pin should be installed during maintenance and cylinder transport to prevent inadvertent pressure release.

CAUTION

With the safety pin installed, it is not possible to inflate the floats using the cockpit inflation lever. The safety pin is for use during maintenance and cylinder transport only and must be removed at all other times.

FLOAT TUBES AND COVERS

Immediately replace any damaged float tube cover to minimize chance of float damage. Inspect float tube condition after each inflation. Refer to R44 Maintenance Manual for periodic inspection, float repacking, and cylinder recharge instructions.

INTENTIONALLY BLANK

FAA APPROVED
R44 II PILOT'S OPERATING HANDBOOK
AIR CONDITIONING SUPPLEMENT

This supplement must be included in the FAA-approved Pilot's Operating Handbook when cabin air conditioning is installed.

Information contained herein supplements or supersedes the basic manual only in those areas listed in this supplement. For limitations, procedures, and performance information not contained in this supplement, consult the basic Pilot's Operating Handbook.

APPROVED BY: *Frank J. Heerman*
acting Manager, Flight Test Branch, ANM-160L
Federal Aviation Administration, LAACO
Transport Airplane Directorate

DATE: MARCH 9, 2004

LOG OF PAGES

Page No.	Date	Page No.	Date
9-11.1	9 Mar 04	9-11.3	9 Mar 04
9-11.2	9 Mar 04	9-11.4	9 Mar 04

SECTION 1: GENERAL

INTRODUCTION

This supplement contains the changes and additional data applicable when cabin air conditioning is installed.

SECTION 2: LIMITATIONS No change.

SECTION 3: EMERGENCY PROCEDURES No change.

SECTION 4: NORMAL PROCEDURES

DAILY OR PREFLIGHT CHECKS

Add to item 9, Cowl door - Left Side:
Compressor belt tension Check

AIR CONDITIONING OPERATION

Air conditioning is controlled by the toggle switch at the forward end of the overhead duct. The switch allows selection of off, low, and high fan settings. The compressor is automatically engaged by switching the fan on. Each of the six outlets may be directed as desired.

NOTE

Evaporator condensate drains from a tube through the aircraft belly. Water drainage during ground operations is normal.

SECTION 5: PERFORMANCE No change.

SECTION 6: WEIGHT AND BALANCE No change.

SECTION 7: SYSTEMS DESCRIPTION

The cabin air conditioning system consists of a compressor accessible through the left engine cowl door, a condenser mounted on the left side of the engine cooling fan scroll, an evaporator and fan assembly mounted to the aft cabin wall, an overhead outlet duct, and interconnecting lines and hoses. The system uses R-134a refrigerant.

The compressor is belt-driven from an engine accessory drive and equipped with an electromagnetic clutch. When the system is off, the compressor clutch is disengaged, allowing the compressor pulley to freewheel.

The evaporator fan draws warm cabin air through the evaporator inlet grill and evaporator where it is cooled. Cooled air is drawn through the fan and blown into the overhead duct.

The system is controlled by a toggle switch on the overhead duct which allows selection of off, low, and high fan settings. The compressor is automatically engaged by switching the fan on. A temperature switch disengages the compressor when evaporator temperature drops below freezing. Safety switches disengage the compressor if refrigerant leakage occurs or if refrigerant pressure is excessive. A full throttle switch disengages the compressor when the engine is near full throttle to ensure that aircraft performance is not affected. The compressor clutch and fan circuits are protected by the A/C circuit breaker.

SECTION 8: HANDLING AND MAINTENANCE

Standard automotive-style charge ports are located inside the left engine cowl door. Normal charge is 1.00 to 1.25 lb R-134a refrigerant. Refer to R44 Maintenance Manual for complete system service procedures.

CAUTION

System may be serviced only by qualified personnel following R44 Maintenance Manual procedures.

FAA APPROVED
R44, R44 II, R44 CADET
PILOT'S OPERATING HANDBOOK

HELISAS AUTOPILOT SUPPLEMENT

This supplement must be included in the FAA-approved Pilot's Operating Handbook when the HeliSAS autopilot is installed.

The information contained herein supplements or supersedes the basic manual only in those areas listed in this supplement. For limitations, procedures, and performance information not contained in this supplement, consult the basic Pilot's Operating Handbook.

APPROVED BY: 
for Manager, Flight Test Branch, ANM-160L
Federal Aviation Administration, LAACO
Transport Airplane Directorate

DATE: September 8, 2014

LOG OF REVISIONS

Page No.	Date	Page No.	Date
9-13.1	17 Dec 19	9-13.7*	17 Dec 19
9-13.2	17 Dec 19	9-13.8*	17 Dec 19
9-13.3	17 Dec 19	9-13.9*	17 Dec 19
9-13.4	17 Dec 19	9-13.10*	17 Dec 19
9-13.5	17 Dec 19	9-13.11*	17 Dec 19
9-13.6*	17 Dec 19	9-13.12*	17 Dec 19

* Manufacturer's data, not FAA approved.

REVISIONS
APPROVED BY: Nevada Jo Ryan Digitally signed by Nevada Jo Ryan
Date: 2019.12.17 10:43:46 -08'00'
Manager, West Flight Test Section, AIR-716
Federal Aviation Administration
Los Angeles

DATE: 17 DEC 2019

SECTION 1: GENERAL

INTRODUCTION

This supplement contains the changes and additional data applicable when the HeliSAS autopilot is installed.

CAUTION

The autopilot is intended to enhance safety by reducing pilot workload. It is not a substitute for adequate pilot skill nor does it relieve the pilot of the responsibility to monitor the flight controls and maintain adequate outside visual reference.

The primary autopilot mode is Stability Augmentation System (SAS) mode which maintains a steady helicopter attitude by applying corrective inputs to the cyclic. The autopilot does not provide any collective or pedal inputs. Additional modes providing heading hold, altitude hold, and navigation functionality are also selectable.

SECTION 2: LIMITATIONS

FLIGHT AND MANEUVER LIMITATIONS

Minimum altitude for use of autopilot ALT mode is 200 feet AGL.

For practice instrument approaches, minimum altitude for use of autopilot VRT mode is 50 feet AGL.

Pilot's hand must be on cyclic grip under the following conditions:

During autopilot engagement or intentional disengagement

At airspeeds less than 50 KIAS when less than 500 feet AGL

SECTION 3: EMERGENCY PROCEDURES

AUTOPILOT DISENGAGEMENT OR FAILURE

The autopilot is designed to automatically disengage if the system detects a fault. Disengagement is normally indicated by four beeps in the headset. If the autopilot does not automatically disengage, failure may be recognized by erratic cyclic control motion, abnormal cyclic stick forces, or deviations in pitch or roll.

1. Continue flight using manual control. If autopilot has not disengaged, manually disengage using cyclic AP OFF button or control panel SAS button.
2. If SAS annunciator on control panel is steady white, re-engagement may be attempted at pilot's discretion.

CAUTION

Due to the unstable nature of helicopters, autopilot disengagement requires immediate pilot attention. Always monitor helicopter attitude and flight controls, and be prepared to take manual control.

NOTE

The system automatically switches off all modes except SAS mode at airspeeds below 44 KIAS or above 130 KIAS, accompanied by a single beep. This is by design and not a system failure. The high speed limit is not intended to provide V_{ne} protection. It is the pilot's responsibility to observe V_{ne} limits.

NOTE

Although unlikely, it is possible for certain faults to cause disengagement without the four-beep aural warning.

SECTION 4: NORMAL PROCEDURES

GENERAL

Autopilot controls and operating modes are described in Section 7, Systems Description.

NOTE

Cyclic friction must be fully off for autopilot to work properly. Cyclic friction will degrade autopilot performance.

STARTING ENGINE AND RUN-UP

After "Hydraulic system", add:

Autopilot Check

NOTE

For autopilot check, wear headset and ensure cyclic friction is off. Engage SAS mode. Verify cyclic exhibits centering tendency and SAS annunciator on control panel turns green. Disengage. Verify 4 beeps in headset, cyclic reverts to normal hydraulic system feel, and SAS annunciator turns white.

TAKEOFF PROCEDURE

Autopilot SAS mode may be engaged as desired on the ground or at any time during the takeoff procedure. Re-trim as necessary to eliminate undesirable cyclic forces.

SECTION 4: NORMAL PROCEDURES (cont'd)

CRUISE

Add:

Engage autopilot modes as desired. In SAS mode, re-trim as necessary to eliminate undesirable cyclic forces.

CAUTION

It is the pilot's responsibility to monitor flight controls, aircraft flightpath, traffic, and terrain even while the autopilot is engaged. The autopilot is designed to disengage in the event of a fault. Be prepared to take control if required.

SECTION 5: PERFORMANCE

No change.

SECTION 6: WEIGHT AND BALANCE

No change.

SECTION 7: SYSTEMS DESCRIPTION

AUTOPILOT

| The HeliSAS autopilot system consists of two electric servomotors, a flight control computer, an autopilot control panel, and control buttons on the cyclic grip. One servomotor controls pitch and is installed in the control tunnel forward of the cyclic stick. The other servomotor controls roll and is installed under the pilot's seat. The servomotors are connected to the cyclic through electromagnetic clutches.

The flight control computer is installed on the forward panel under the pilot's seat, and the autopilot control panel is installed in the avionics stack.

In addition to the autopilot system components, an onboard attitude source such as an Attitude Heading Reference System (AHRS) is required.

The primary autopilot mode is Stability Augmentation System (SAS) mode which maintains a steady helicopter attitude by applying corrective inputs to the cyclic. This is felt as a light cyclic centering force. The autopilot senses aircraft attitude using a combination of sensors in the flight control computer and the onboard attitude source. The computer then sends signals to the servomotors which are connected to the bottom of the cyclic in the control tunnel. Additional modes may be layered on top of SAS mode and are described below.

SECTION 7: SYSTEMS DESCRIPTION (cont'd)

AUTOPILOT (cont'd)

Heading Mode (HDG) – maintains the heading selected by the heading bug on the directional gyro or Horizontal Situation Indicator (HSI) display. Aircraft can be steered using the heading bug.

NOTE

For large heading or course changes, the autopilot will use a maximum of 20° bank.

Altitude Mode (ALT) – maintains altitude at the time of engagement or of last TRIM button release. The target altitude is reset each time the TRIM button is pressed and released.

NOTE

The autopilot uses pitch attitude to maintain altitude or follow an approach glidepath. It does not have any control of power setting. The pilot must manage power with the collective to control speed and rate of climb or descent. Make small, smooth power changes to allow the system to adjust to new power settings.

Navigation Mode (NAV) – tracks the active GPS or VLOC course displayed on the Course Deviation Indicator (CDI). If no CDI is installed, NAV will only track the active GPS course displayed on the GPS.

NAV may be armed prior to intercepting the active course. NAV annunciator is white when NAV is armed and turns green at course intercept. If HDG is active when NAV is armed, the autopilot will fly the selected heading until course intercept. If HDG is not active, the autopilot will select a 45° intercept angle.

SECTION 7: SYSTEMS DESCRIPTION (cont'd)

AUTOPILOT (cont'd)

Vertical Navigation Mode (VRT) – tracks an ILS glideslope or GPS approach vertical guidance. Arm VRT (annunciator turns white when armed) prior to intercepting the glidepath. VRT annunciator will turn green at glidepath intercept.

NOTE

Pushing the ALT button while VRT is armed or active will turn off VRT. VRT must be re-armed or re-engaged as desired.

NOTE

Reducing power to approach setting just prior to glidepath intercept is recommended.

SECTION 7: SYSTEMS DESCRIPTION (cont'd)

AUTOPILOT (cont'd)

Backcourse Mode (BC) – reverse CDI sensing for backcourse approaches. Course on HSI should be set so that tail of course pointer points toward runway (set to inbound front course).

The control panel has a row of buttons to control autopilot modes and annunciators to indicate mode status. A dark annunciator indicates that a mode is off, a white annunciator indicates that a mode is armed or on standby, and a green annunciator indicates that a mode is active.

When the avionics master is switched on, the autopilot performs a self-test and then enters SAS standby mode. All of the control panel indicators flash alternating white and green during the self-test. Four headset beeps occur at the beginning of the self-test as a check of the aural warning function. The SAS annunciator on the control panel turns steady white when the self-test is complete.

NOTE

Autopilot will not enter standby mode if attitude indicator is not functioning or indicated bank angle is greater than 6 degrees.

SECTION 7: SYSTEMS DESCRIPTION (cont'd)

AUTOPILOT (cont'd)

The autopilot SAS mode is engaged either by pressing the SAS button on the control panel or by pressing the TRIM button on the cyclic for more than 1.25 seconds. Additional modes are engaged by pressing the appropriate button on the control panel. The additional modes are disabled and will not engage at airspeeds below 44 KIAS or above 130 KIAS.

To disengage any mode, push the appropriate button on the control panel.

NOTE

Disengaging SAS mode will also disengage all other modes.

Modes may also be disengaged using the AP OFF button on the cyclic. If only SAS mode is engaged, push the AP OFF button once to disengage. If additional modes are engaged, push the AP OFF button once to disengage all modes except SAS and a second time to disengage SAS mode, or push and hold the AP OFF button to disengage all modes including SAS.

NOTE

SAS disengagement should always be accompanied by four beeps in the headset. If beeps do not occur, maintenance is required.

Safety monitors automatically disengage individual modes or the entire system if a fault is detected. Automatic disengagement of SAS mode (or the entire system) is indicated by four beeps in the headset. Automatic disengagement of any mode other than SAS is indicated by a single beep in the headset. There is no audio indication for intentional disengagement of modes other than SAS.

SECTION 7: SYSTEMS DESCRIPTION (cont'd)

AUTOPILOT (cont'd)

NOTE

The system also automatically reverts to SAS mode at airspeeds below 44 KIAS or above 130 KIAS, accompanied by a single beep. The high speed limit is not intended to provide V_{ne} protection. It is the pilot's responsibility to observe V_{ne} limits.

The TRIM button is used to re-set the target attitude (to re-trim) while in SAS mode. Use a small amount of force to override the autopilot and then push and release the TRIM button at the new desired condition. If the force to override is objectionable, the TRIM button may be held down during maneuvers. The system will re-trim to the attitude at which the TRIM button is released.

NOTE

The system will not re-trim to more than 6° nose down, 11° nose up, or 10° of bank. If a re-trim is attempted outside these limits, the system will trim to the limiting value.

NOTE

When engaging SAS mode from standby, the autopilot uses the helicopter attitude at the time SAS mode is engaged as the target (trim) attitude. For large pitch and roll angles at the time of engagement, a target of 2° nose up pitch and 0° (level) roll is used.

The autopilot is protected by a dedicated circuit breaker on the avionics bus (autopilot is not powered with the avionics master switch off).

SECTION 7: SYSTEMS DESCRIPTION (cont'd)

REMOVABLE FLIGHT CONTROLS

On later aircraft, disconnect the electrical connector for the left-hand trim button located near the quick release pin before removing the left cyclic grip. Reconnect the connector when installing the left cyclic grip.

SECTION 8: HANDLING AND MAINTENANCE

No change.

SECTION 10: SAFETY TIPS

The autopilot is intended to reduce pilot workload and enhance safety. It is important that pilots do not misuse this capability and allow their attention to be diverted. Pilots should continue monitoring the flight controls and helicopter attitude as well as looking for traffic and other obstacles. Autopilot disengagement requires immediate pilot attention. Pilots must always be prepared to take manual control.

The autopilot is not certified for flight in Instrument Meteorological Conditions (IMC). Adhering to appropriate VFR weather minimums is essential for safety.

If an inadvertent loss of outside visual reference occurs, the pilot must regain visual conditions as quickly as possible while avoiding abrupt, disorienting maneuvers. The following procedure is recommended:

1. If not already engaged, immediately engage autopilot SAS mode and allow autopilot to recover from unusual attitude if one has occurred.
2. Select a heading and altitude to ensure terrain and obstacle clearance. Turns and/or climbs may be required. Engage additional autopilot modes as desired for workload reduction.
3. While maintaining terrain and obstacle clearance, maneuver toward conditions of improved visibility.

FAA APPROVED
R44 II PILOT'S OPERATING HANDBOOK
OPTIONAL AVIONICS SUPPLEMENT

This supplement must be included in the FAA-approved Pilot's Operating Handbook when certain factory-supplied optional avionics are installed.

Information contained herein supplements or supersedes the basic manual only in those areas listed in this supplement. For limitations, procedures, and performance information not contained in this supplement, consult the basic Pilot's Operating Handbook.

APPROVED BY: *Hsin Tang*
Acting Manager, West Flight Test Section, AIR-716
Federal Aviation Administration
Los Angeles, CA

DATE: *May 7, 2018*

LOG OF PAGES

Page No.	Date	Page No.	Date
9-14.1	7 May 18	9-14.6*	7 May 18
9-14.2*	7 May 18	9-14.7*	7 May 18
9-14.3	7 May 18	9-14.8*	7 May 18
9-14.4*	7 May 18	9-14.9*	7 May 18
9-14.5*	7 May 18	9-14.10*	7 May 18

* Manufacturer's data, not FAA approved.

SECTION 1: GENERAL

INTRODUCTION

This supplement provides additional information for certain avionics options. A set of manufacturers' instructions for all installed avionics is provided with each new helicopter.

The following equipment is addressed in this supplement:

- Aspen Avionics EFD 1000H PFD and EFD 500H MFD
- Garmin G500H avionics system with non-touch screen display (GDU 620)
- Garmin G500H avionics system with touch screen display (GDU 1060 TXi or GDU 700L TXi)

NOTE

For all Robinson Primary Flight Display (PFD)/ Multi Function Display (MFD) installations, the airspeed indicator, altimeter, compass, tachometer, and engine instruments are retained. Pilots should use the traditional instruments as primary unless fully familiar with the installed avionics.

SECTION 2: LIMITATIONS	No change.
SECTION 3: EMERGENCY PROCEDURES	No change.
SECTION 4: NORMAL PROCEDURES	No change.
SECTION 5: PERFORMANCE	No change.
SECTION 6: WEIGHT AND BALANCE	No change.
SECTION 7: SYSTEMS DESCRIPTION	See below.
SECTION 8: HANDLING AND MAINTENANCE	
No change.	

SECTION 7: SYSTEMS DESCRIPTION

ASPEN EFD 1000H PFD AND EFD 500H MFD

The Aspen Electronic Flight Display (EFD) 1000H is a Primary Flight Display (PFD) optimized for helicopter use. It is available in a "Pilot" (basic) version or "Pro" (with more advanced navigation features) version.

The Aspen EFD 500H is a Multifunction Display (MFD) optimized for helicopter use.

Robinson configurations are either a single EFD 1000H PFD or a dual installation with one EFD 1000H PFD and one EFD 500H MFD. A typical dual-installation instrument panel is illustrated on the following page.

The manufacturer's documents for the EFD 1000H and EFD 500H are:

Title	Document No.
<i>Aspen Avionics Evolution Flight Display EFD 1000H PFD Pilot's Guide</i>	091-00012-001
<i>Aspen Avionics Evolution Flight Display EFD 1000H/500H MFD Pilot's Guide</i>	091-00013-001

NOTE

A Robinson part no. D327-4 light filter may be used to reduce reflections in the windshield at night. The light filter is installed by clipping it to the front of the display. Filter use is at pilot discretion.

SECTION 7: SYSTEMS DESCRIPTION (cont'd)

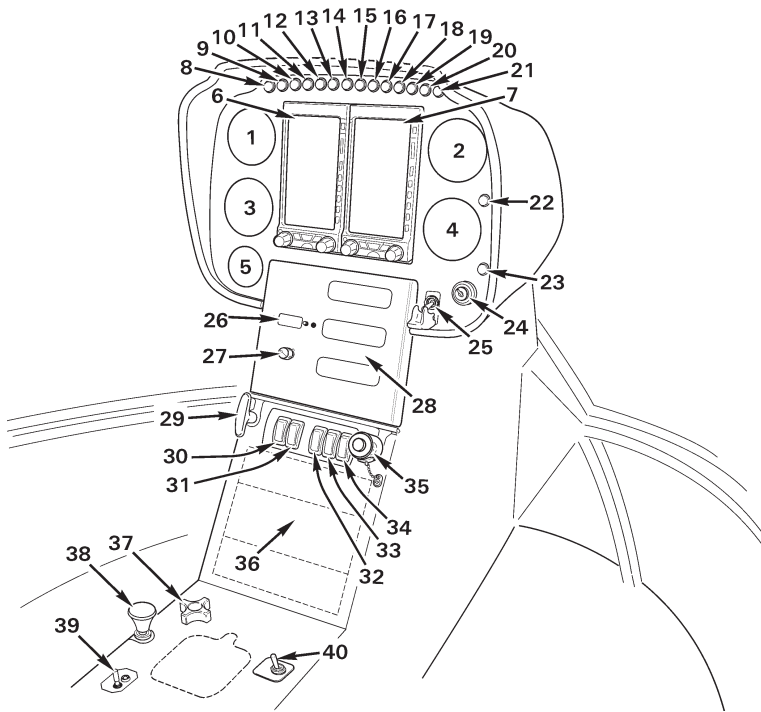

- | | |
|-----------------------------|---------------------------------|
| 1. AIRSPEED INDICATOR | 21. GOVERNOR-OFF LIGHT |
| 2. ENGINE AND ROTOR TACHS | 22. FULL THROTTLE LIGHT |
| 3. ALTIMETER | 23. ROTOR BRAKE LIGHT |
| 4. MANIFOLD PRESSURE GAGE | 24. IGNITION SWITCH |
| 5. CLOCK | 25. CLUTCH ACTUATOR SWITCH |
| 6. MULTI-FUNCTION DISPLAY | 26. OUTSIDE AIR TEMP/VOLTMETER |
| 7. PRIMARY FLIGHT DISPLAY | 27. PANEL LIGHTS DIMMER |
| 8. CLUTCH ACTUATOR LIGHT | 28. ENGINE INSTRUMENTS |
| 9. M.R. GEARBOX TEMP LIGHT | 29. CABIN AIR |
| 10. M.R. GEARBOX CHIP LIGHT | 30. NAVIGATION LIGHTS SWITCH |
| 11. CARBON MONOXIDE LIGHT | 31. ANTI-COLLISION LIGHT SWITCH |
| 12. STARTER-ON LIGHT | 32. AVIONICS MASTER SWITCH |
| 13. T.R. GEARBOX CHIP LIGHT | 33. ALTERNATOR SWITCH |
| 14. LOW FUEL LIGHT | 34. BATTERY SWITCH |
| 15. LOW RPM LIGHT | 35. MIXTURE CONTROL |
| 16. FUEL FILTER LIGHT | 36. AVIONICS STACK |
| 17. AUX FUEL PUMP LIGHT | 37. CYCLIC FRICTION |
| 18. ALT LOW VOLTAGE LIGHT | 38. CABIN HEAT |
| 19. ENGINE FIRE LIGHT | 39. ELT SWITCH (OPT'L) |
| 20. OIL PRESSURE LIGHT | 40. PITOT HEAT SWITCH (OPT'L) |

**OPTIONAL INSTRUMENT PANEL WITH
ASPEN EFD 1000H PFD and EFD 500H MFD**

(Exact panel configuration may vary with optional equipment and date of helicopter manufacture.)

SECTION 7: SYSTEMS DESCRIPTION (cont'd)

GARMIN G500H SYSTEM WITH GDU 620 (NON-TOUCH SCREEN) DISPLAY

The Garmin GDU 620 display is a split screen PFD/MFD designed for use with Garmin's G500H helicopter avionics system.

A typical Robinson Installation is illustrated on the following page.

The manufacturer's document for the G500H system with GDU 620 display is:

Title	Document No.
<i>Garmin G500H Pilot's Guide</i>	190-01150-02

NOTE

A Robinson part no. D327-1 light filter may be used to reduce reflections in the windshield at night. The light filter is installed by clipping it to the front of the display. Filter use is at pilot discretion.

SECTION 7: SYSTEMS DESCRIPTION (cont'd)

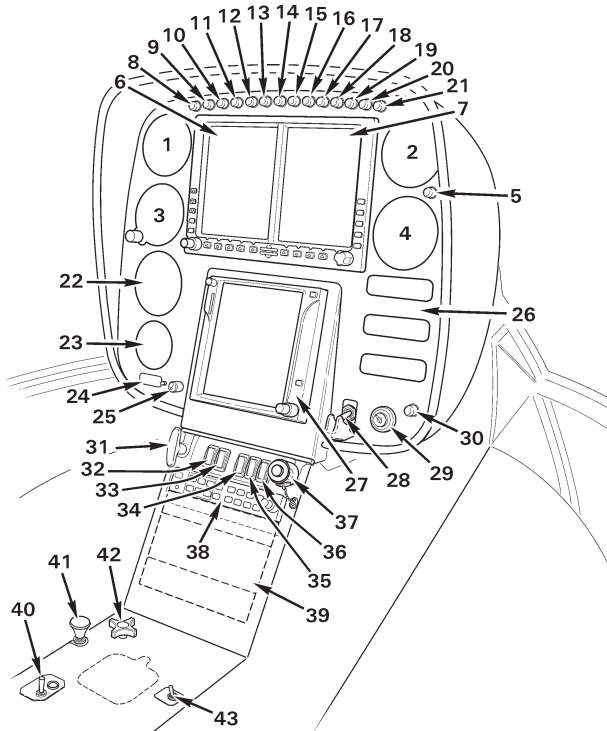

- | | |
|-----------------------------|---------------------------------|
| 1. AIRSPEED INDICATOR | 23. CLOCK |
| 2. ENGINE AND ROTOR TACHS | 24. OUTSIDE AIR TEMP/VOLTMETER |
| 3. ALTIMETER | 25. PANEL LIGHTS DIMMER |
| 4. MANIFOLD PRESSURE GAGE | 26. ENGINE INSTRUMENTS |
| 5. FULL THROTTLE LIGHT | 27. GPS NAVIGATOR |
| 6. MULTI-FUNCTION DISPLAY | 28. CLUTCH ACTUATOR SWITCH |
| 7. PRIMARY FLIGHT DISPLAY | 29. IGNITION SWITCH |
| 8. CLUTCH ACTUATOR LIGHT | 30. ROTOR BRAKE LIGHT |
| 9. M.R. GEARBOX TEMP LIGHT | 31. CABIN AIR |
| 10. M.R. GEARBOX CHIP LIGHT | 32. NAVIGATION LIGHTS SWITCH |
| 11. CARBON MONOXIDE LIGHT | 33. ANTI-COLLISION LIGHT SWITCH |
| 12. STARTER-ON LIGHT | 34. AVIONICS MASTER SWITCH |
| 13. T.R. GEARBOX CHIP LIGHT | 35. ALTERNATOR SWITCH |
| 14. LOW FUEL LIGHT | 36. BATTERY SWITCH |
| 15. LOW RPM LIGHT | 37. MIXTURE CONTROL |
| 16. FUEL FILTER LIGHT | 38. AUDIO CONTROL |
| 17. AUX FUEL PUMP LIGHT | 39. AVIONICS STACK |
| 18. ALT LOW VOLTAGE LIGHT | 40. ELT SWITCH (OPT'L) |
| 19. ENGINE FIRE LIGHT | 41. CABIN HEAT |
| 20. OIL PRESSURE LIGHT | 42. CYCLIC FRICTION |
| 21. GOVERNOR-OFF LIGHT | 43. PITOT HEAT SWITCH (OPT'L) |
| 22. OPTIONAL INSTRUMENT | |

**OPTIONAL INSTRUMENT PANEL WITH
GARMIN G500H SYSTEM WITH GDU 620 DISPLAY**

(Exact panel configuration may vary with optional equipment and date of helicopter manufacture.)

SECTION 7: SYSTEMS DESCRIPTION (cont'd)

**GARMIN G500H SYSTEM WITH GDU 1060 TXi OR
GDU 700L TXi TOUCH SCREEN DISPLAY**

The Garmin GDU 1060 TXi is a 10.6 inch diagonal split screen PFD/MFD designed for use with Garmin's G500H Helicopter Avionics System.

The Garmin GDU 700L TXi is a 7 inch diagonal PFD/MFD designed for use with Garmin's G500H helicopter avionics system.

Both displays use a touch screen for pilot interface, with primary functions duplicated via knobs and buttons.

Robinson installations for each of the displays are illustrated on the following pages.

The manufacturer's document for the G500H system with GDU 1060 TXi or GDU 700L TXi display is:

Title	Document No.
<i>Garmin G500(H)/G600/G700 TXi Pilot's Guide</i>	190-01717-11

SECTION 7: SYSTEMS DESCRIPTION (cont'd)

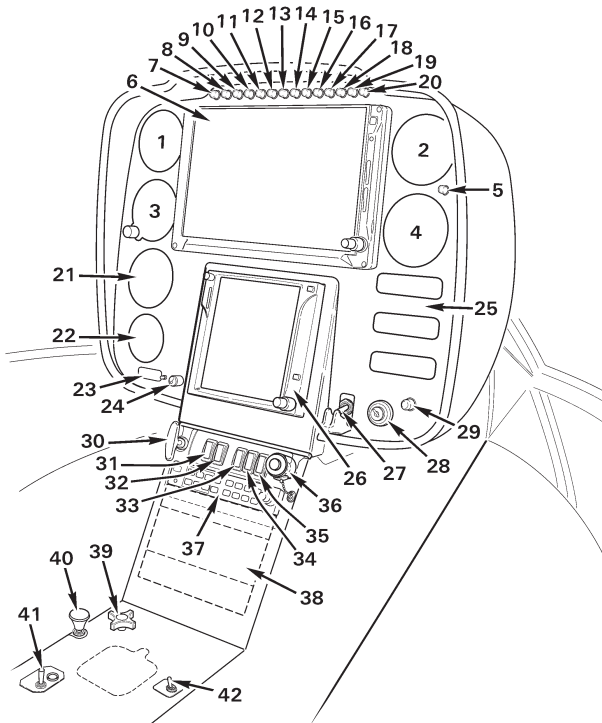

- | | |
|------------------------------|---------------------------------|
| 1. AIRSPEED INDICATOR | 22. CLOCK |
| 2. ENGINE AND ROTOR TACHS | 23. OUTSIDE AIR TEMP/VOLTMETER |
| 3. ALTIMETER | 24. PANEL LIGHTS DIMMER |
| 4. MANIFOLD PRESSURE GAGE | 25. ENGINE INSTRUMENTS |
| 5. FULL THROTTLE LIGHT | 26. GPS NAVIGATOR |
| 6. PRIMARY/MULTI FXN DISPLAY | 27. CLUTCH ACTUATOR SWITCH |
| 7. CLUTCH ACTUATOR LIGHT | 28. IGNITION SWITCH |
| 8. M.R. GEARBOX TEMP LIGHT | 29. ROTOR BRAKE LIGHT |
| 9. M.R. GEARBOX CHIP LIGHT | 30. CABIN AIR |
| 10. CARBON MONOXIDE LIGHT | 31. NAVIGATION LIGHTS SWITCH |
| 11. STARTER-ON LIGHT | 32. ANTI-COLLISION LIGHT SWITCH |
| 12. T.R. GEARBOX CHIP LIGHT | 33. AVIONICS MASTER SWITCH |
| 13. LOW FUEL LIGHT | 34. ALTERNATOR SWITCH |
| 14. LOW RPM LIGHT | 35. BATTERY SWITCH |
| 15. FUEL FILTER LIGHT | 36. MIXTURE CONTROL |
| 16. AUX FUEL PUMP LIGHT | 37. AUDIO CONTROL |
| 17. ALT LOW VOLTAGE LIGHT | 38. AVIONICS STACK |
| 18. ENGINE FIRE LIGHT | 39. CYCLIC FRICTION |
| 19. OIL PRESSURE LIGHT | 40. CABIN HEAT |
| 20. GOVERNOR-OFF LIGHT | 41. ELT SWITCH (OPT'L) |
| 21. OPTIONAL INSTRUMENT | 42. PITOT HEAT SWITCH (OPT'L) |

**OPTIONAL INSTRUMENT PANEL WITH
GARMIN G500H SYSTEM WITH GDU 1060 TXi DISPLAY**

(Exact panel configuration may vary with optional equipment and date of helicopter manufacture.)

SECTION 7: SYSTEMS DESCRIPTION (cont'd)

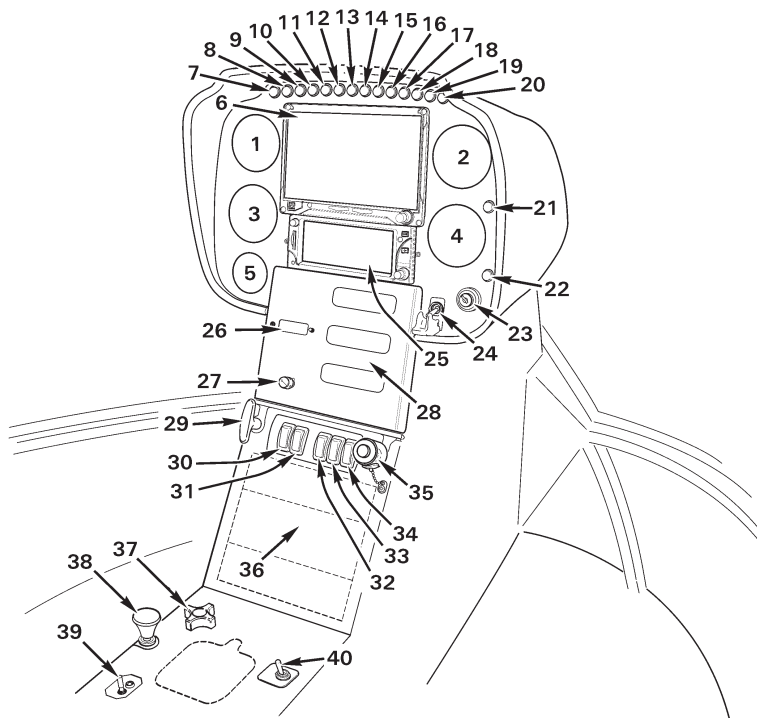

- | | |
|------------------------------|---------------------------------|
| 1. AIRSPEED INDICATOR | 21. FULL THROTTLE LIGHT |
| 2. ENGINE AND ROTOR TACHS | 22. ROTOR BRAKE LIGHT |
| 3. ALTIMETER | 23. IGNITION SWITCH |
| 4. MANIFOLD PRESSURE GAGE | 24. CLUTCH ACTUATOR SWITCH |
| 5. CLOCK | 25. GPS NAVIGATOR |
| 6. PRIMARY/MULTI FXN DISPLAY | 26. OUTSIDE AIR TEMP/VOLTMETER |
| 7. CLUTCH ACTUATOR LIGHT | 27. PANEL LIGHTS DIMMER |
| 8. M.R. GEARBOX TEMP LIGHT | 28. ENGINE INSTRUMENTS |
| 9. M.R. GEARBOX CHIP LIGHT | 29. CABIN AIR |
| 10. CARBON MONOXIDE LIGHT | 30. NAVIGATION LIGHTS SWITCH |
| 11. STARTER-ON LIGHT | 31. ANTI-COLLISION LIGHT SWITCH |
| 12. T.R. GEARBOX CHIP LIGHT | 32. AVIONICS MASTER SWITCH |
| 13. LOW FUEL LIGHT | 33. ALTERNATOR SWITCH |
| 14. LOW RPM LIGHT | 34. BATTERY SWITCH |
| 15. FUEL FILTER LIGHT | 35. MIXTURE CONTROL |
| 16. AUX FUEL PUMP LIGHT | 36. AVIONICS STACK |
| 17. ALT LOW VOLTAGE LIGHT | 37. CYCLIC FRICTION |
| 18. ENGINE FIRE LIGHT | 38. CABIN HEAT |
| 19. OIL PRESSURE LIGHT | 39. ELT SWITCH (OPT'L) |
| 20. GOVERNOR-OFF LIGHT | 40. PITOT HEAT SWITCH (OPT'L) |

**OPTIONAL INSTRUMENT PANEL WITH
GARMIN G500H SYSTEM WITH GDU 700L TXi DISPLAY**

(Exact panel configuration may vary with optional equipment and date of helicopter manufacture.)

**FAA APPROVED
R44, R44 II, R44 CADET
PILOT'S OPERATING HANDBOOK**

LITHIUM-ION BATTERY SUPPLEMENT

This supplement must be included in the FAA-approved Pilot's Operating Handbook when the lithium-ion main battery is installed.

Information contained herein supplements or supersedes the basic manual only in those areas listed in this supplement. For limitations, procedures, and performance information not contained in this supplement, consult the basic Pilot's Operating Handbook.

APPROVED BY: **HIEN H TONG** Digitally signed by HIEN H TONG
Date: 2020.12.10 13:39:02 -08'00'
for Manager, West Flight Test Section, AIR-716
Federal Aviation Administration
Los Angeles, CA

DATE: 10 DEC 2020

LOG OF PAGES

Page No.	Date	Page No.	Date
9-15.1	10 Dec 20	9-15.4*	10 Dec 20
9-15.2	10 Dec 20	9-15.5*	10 Dec 20
9-15.3	10 Dec 20	9-15.6*	10 Dec 20

* Manufacturer's data, not FAA approved.

SECTION 1: GENERAL

INTRODUCTION

This supplement contains changes and additional data applicable when the lithium-ion main battery is installed.

SECTION 2: LIMITATIONS

No change.

SECTION 3: EMERGENCY PROCEDURES

WARNING/CAUTION LIGHTS

BATT FAULT Indicates abnormal battery operation. Charging, discharging, or both may be disabled. Land as soon as practical. Alternator will continue to supply power in flight.

NOTE

Battery's internal circuitry may disable charge/discharge functions due to over-temperature, over/under voltage, or excessive current draw. A flashing light means the fault may be recoverable (battery will reset itself) either when the condition improves or during a power cycle at the next landing. A steady light means battery maintenance or replacement will likely be necessary.

SECTION 4: NORMAL PROCEDURES

STARTING ENGINE AND RUN-UP

After Battery switch ON, add:

Battery heater indicator lightExtinguished

NOTE

The lithium-ion battery has a built-in heater. When the battery switch is ON, the BATT HEATER light illuminates during the heating cycle and extinguishes when the battery is warm enough to attempt a start. The indicator light is disabled after engine start, but the heater will continue to cycle as required to maintain optimum battery temperature.

SECTION 5: PERFORMANCE No change.

SECTION 6: WEIGHT AND BALANCE No change.

SECTION 7: SYSTEMS DESCRIPTION

ELECTRICAL SYSTEM

A 17 amp-hour lithium-ion battery replaces the standard 24-volt lead-acid main battery. The lithium-ion battery includes built-in circuitry that monitors temperature, voltage, and current draw and manages battery charge and discharge. The circuitry automatically disables charge and/or discharge if any electrical or thermal problems are detected. The circuitry will also interrupt power if a start is attempted with insufficient charge to prevent permanent battery damage. The battery uses lithium-iron-phosphate chemistry which is less susceptible to thermal runaway than some other lithium battery chemistries.

The metal battery case is designed to contain any heat or gases generated within the battery and is vented overboard. No venting should occur during normal operation.

Two annunciator panel segments, BATT FAULT and BATT HEATER, show battery status. The annunciator panel test button should cause these segments to illuminate along with the rest of the annunciator panel. The segments will also illuminate briefly when the battery switch is turned on after several hours of inactivity.

BATT FAULT illuminates if the battery has an over- or under-voltage condition, an over-temperature condition, or if current draw exceeds limits. A flashing light indicates a recoverable fault. The light may go out if the fault corrects itself (e.g. temperature decrease) or may go out as a result of a power cycle at the next landing. A steady light indicates battery maintenance or replacement may be required. The emergency procedure for a fault light (flashing or steady) is to land as soon as practical. The alternator will continue to supply electrical power during the landing.

SECTION 7: SYSTEMS DESCRIPTION (cont'd)

ELECTRICAL SYSTEM (cont'd)

The battery incorporates an internal heater for cold weather operation. The heater attempts to maintain a battery temperature of at least 50°F (10°C). When the battery is switched ON, BATT HEATER illuminates while the heater is warming the battery and extinguishes when the battery is warm enough to attempt an engine start. On very cold days, the heating cycle may take 10 minutes or more. The heater light is disabled while the engine is running but the heater will continue to function as long as the battery switch is ON.

SECTION 8: HANDLING AND MAINTENANCE

Nominal charging voltage for the lithium-ion battery is 28.8 volts. Some lead-acid chargers may not provide enough voltage to fully charge the battery. Ensure charging equipment is compatible with lithium-ion batteries.

Refer to the R44 Maintenance Manual for additional handling and maintenance instructions.

THIS PAGE INTENTIONALLY BLANK