

CHAPTER 79**ENGINE OIL SYSTEM**

<u>Section</u>	<u>Title</u>	<u>Page</u>
79-00	Description	79.1
79-10	Scroll and Fanwheel Assemblies	79.3
79-11	Fanwheel-to-Inlet Gaps	79.3
79-20	Oil Tank Assembly	79.5
79-21	Oil Temperature Sender	79.6
79-22	Sight Gage	79.7
79-30	Engine Oil Cooler	79.7
79-40	Engine Oil Filter	79.7
79-50	Engine Oil Line Assemblies and Fittings	79.8

Intentionally Blank

CHAPTER 79

ENGINE OIL SYSTEM

79-00 Description

The R66 helicopter has a dry-sump engine oil system. Oil is stored in a remote tank located in the main rotor gearbox compartment. Refer to Section 12-60 for oil servicing instructions. A Rolls-Royce-supplied oil temperature sender is mounted on the inboard side of the oil tank.

Oil circulates through the engine oil system via three oil delivery lines. Refer to Figure 79-1. Cool oil exits the oil tank and enters the engine, hot oil exits the engine and enters the engine oil cooler, and cooled oil exits the oil cooler and returns to the oil tank. An oil tank vent line is plumbed to the engine accessory gearbox, which is vented to the exhaust pipe.

The engine oil cooler has an internal thermostat (thermostat initial closure 70°C, full closure 81°C) and pressure relief valve. The thermostat maintains normal system operating pressure by allowing cool oil to bypass the heat exchanger and return to the oil tank. Higher than normal system pressure will open a pressure relief valve. When draining the oil system, residual oil is trapped in the bottom corner of the oil cooler due to the oil cooler installation angle in the R66. An oil cooler drain plug allows the technician to drain trapped oil during servicing.

The engine oil system includes an oil pump, oil filter and regulating valve, an oil sump tank, a check valve, and two magnetic plug inserts. Refer to RR300 OMM for a complete description of the engine oil system.

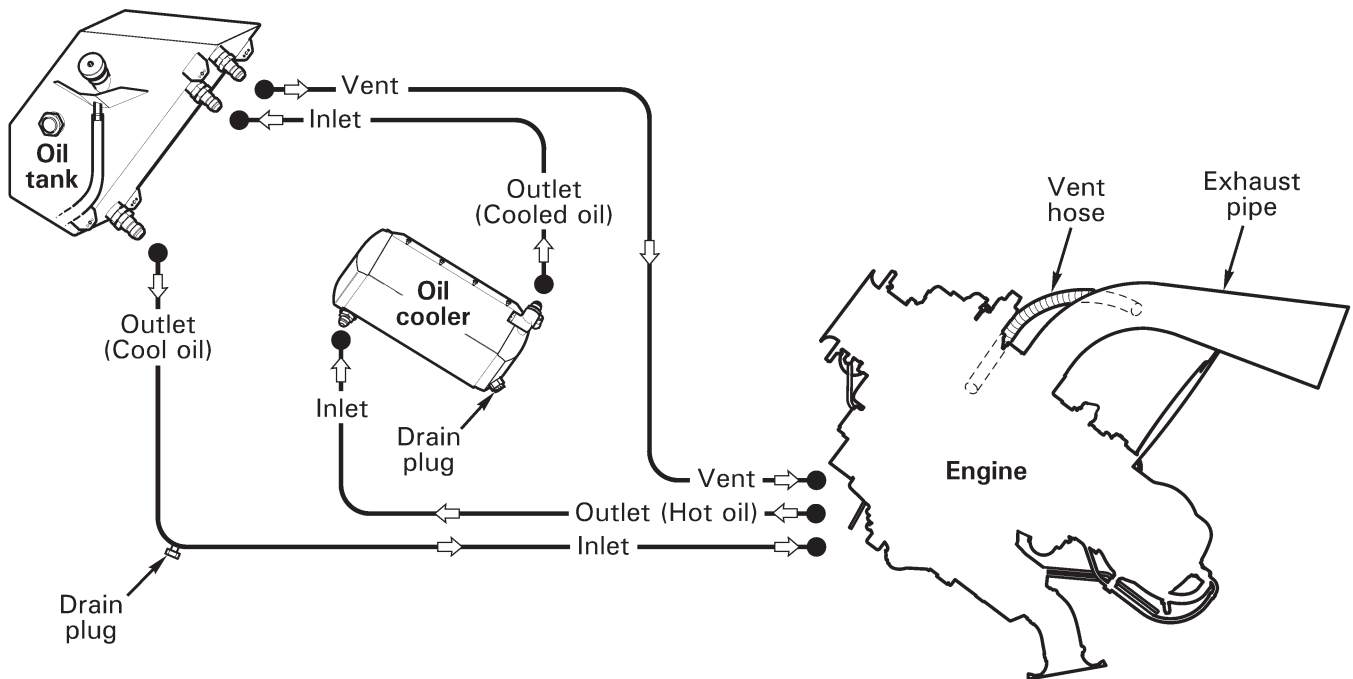

FIGURE 79-1 ENGINE OIL SYSTEM SCHEMATIC

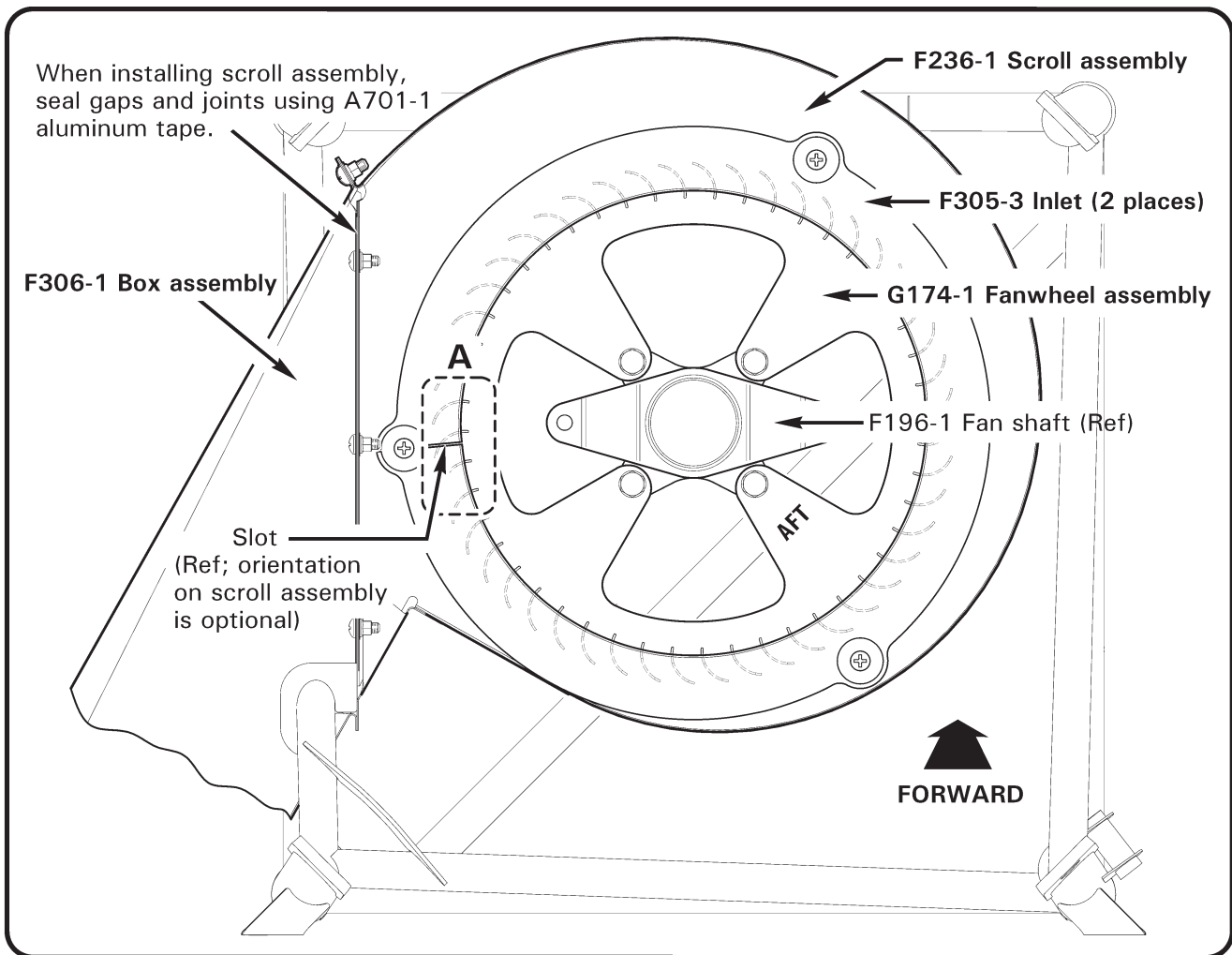
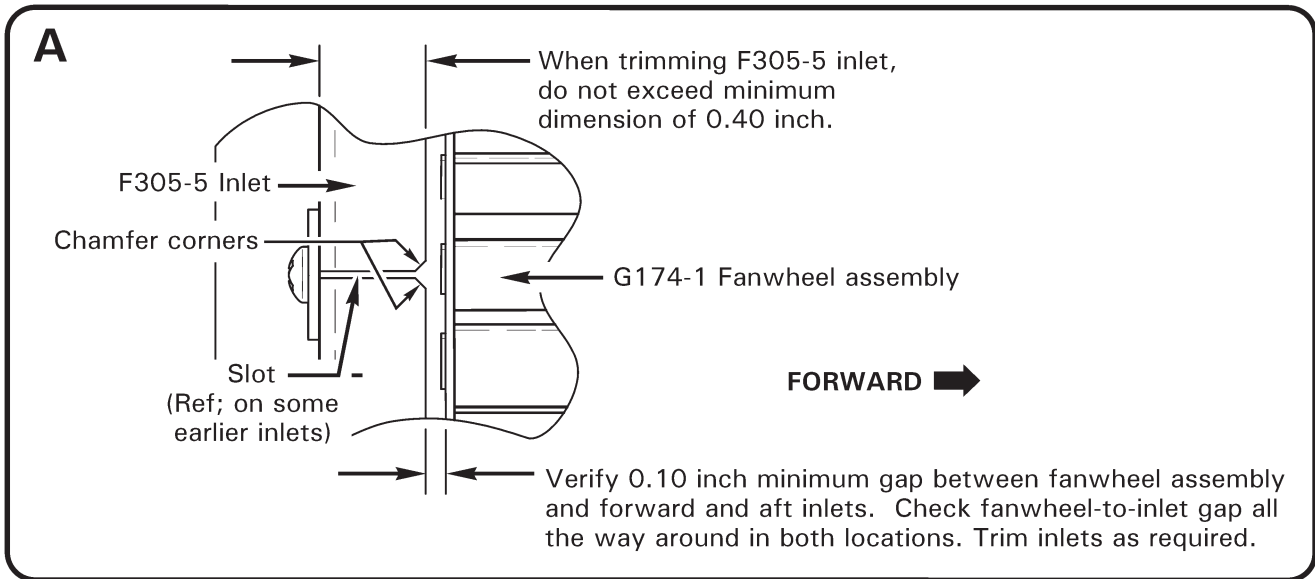

FIGURE 79-2 SCROLL AND FANWHEEL ASSEMBLIES

79-10 Scroll and Fanwheel Assemblies

A. Removal

1. Remove F196-1 fan shaft per § 65-10.
2. Refer to Figure 79-2. Remove perimeter screws securing F236-1 scroll assembly to F306-1 box assembly.
3. Remove aluminum tape sealing gaps & joints, or gently pull scroll away from box assembly and, using a scribe or similar sharp instrument, tear aluminum tape sealing gaps & joints. Remove scroll, with G174-1 fanwheel assembly inside, up through frame.
4. Remove hardware securing forward or aft F305-5 inlet to scroll; remove inlet & fanwheel. Remove damaged aluminum tape from scroll and box assembly.

B. Installation

1. Refer to Figure 79-2. Observing "AFT" orientation marking on fanwheel plate, place G174-1 fanwheel assembly inside F236-1 scroll assembly accordingly. Position F305-5 inlets on scroll and install hardware. Verify security.
2. Lower scroll, with fanwheel inside, through frame and install hardware securing scroll to F306-1 box assembly. Verify security. Seal gaps & joints using A701-1 aluminum tape.
3. Install F196-1 fan shaft per § 65-10.

79-11 Fanwheel-to-Inlet Gaps

A. Measuring Gap

1. Remove tailcone cowling assembly per § 53-23.
2. Refer to Figure 79-2. Verify 0.10 inch minimum gap between G174-1 fanwheel assembly and forward and aft F305-5 inlets. Check gap all the way around; rotate fanwheel and check gap again (several positions). If gap is within limits at forward and aft inlets, no further action is required.
3. Verify proper tail rotor driveline shimming per § 65-30.
4. Trim inlets as required per Part B.
5. Install tailcone cowling assembly per § 53-23.

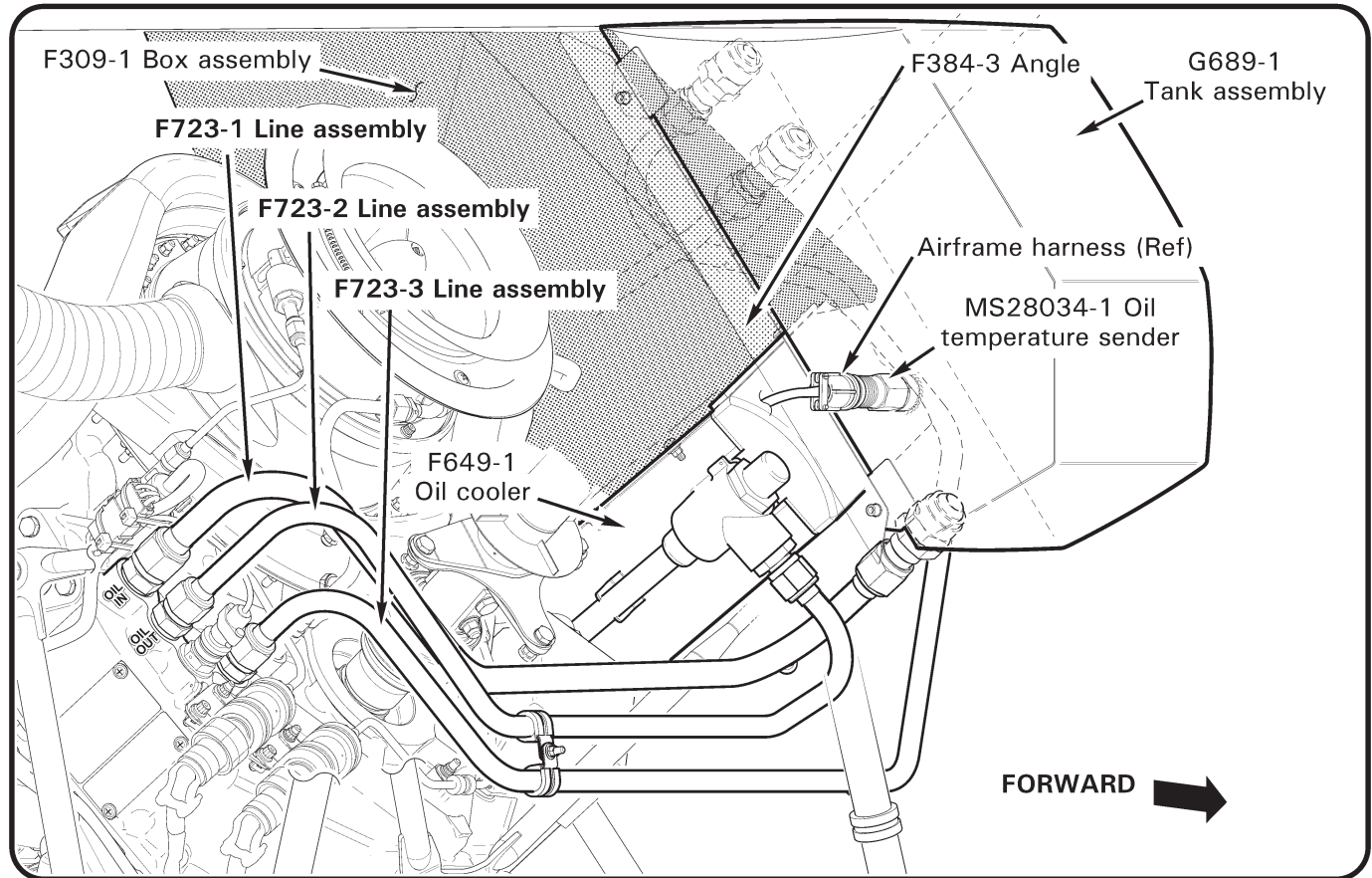
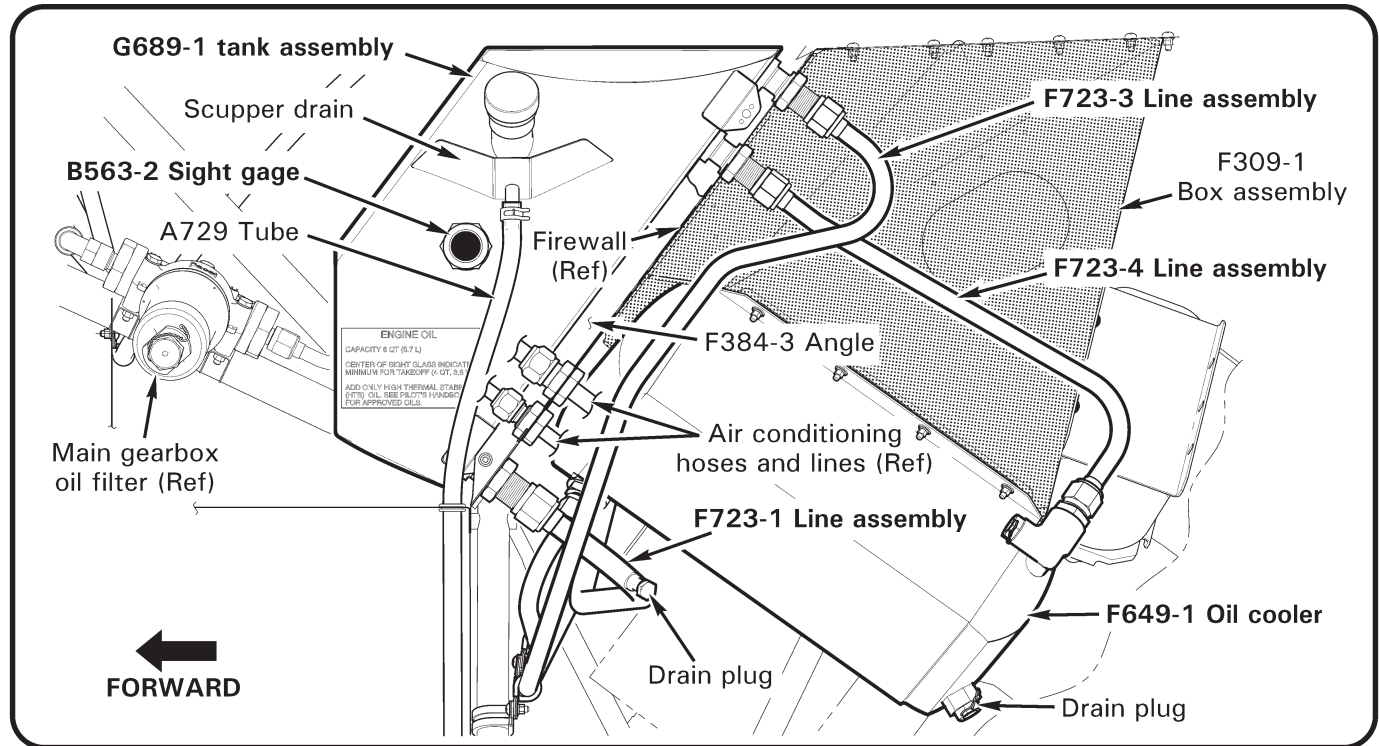

FIGURE 79-3 ENGINE OIL SYSTEM

79-11 Fanwheel-to-Inlet Gaps (continued)

B. Trimming Inlets

1. Refer to Figure 79-2. Remove hardware securing F305-5 inlets to F236-1 scroll assembly.
2. If inlets are slotted, carefully twist inlets over F196-1 fan shaft and remove inlets. If inlets are not slotted, remove hardware securing fan shaft to C947-3 plate assemblies, noting hardware removed, and remove inlets.
3. Refer to Figure 79-2, Detail A. Trim inlets as required to meet minimum fanwheel-to-inlet gap. Do not exceed minimum inlet dimensions.
4. Refer to § 20-70. Smooth inlet edges and coat bare metal with primer. Touch-up primed area using dark gray Dupont Imron polyurethane enamel in accordance with paint manufacturer's recommendations.
5. If inlets are slotted, carefully twist inlets over fan shaft and install hardware securing inlets to scroll assembly (slot orientation is optional). Verify security.
6. If inlets are not slotted, install inlets around fan shaft and install hardware securing inlets to scroll assembly. Verify security. Install hardware securing fan shaft to plate assemblies, standard torque hardware per § 20-32, and torque stripe per Figure 5-1.
7. Measure fanwheel-to-inlet gaps per Part A. Repeat procedure as required for minimum 0.10 inch gap at forward and aft inlets.

79-20 Oil Tank Assembly

A. Removal

1. Drain engine oil per § 12-60.
2. Remove tailcone cowling assembly per § 53-23; open main gearbox access door.
3. Air-conditioned ships: Recover refrigerant per § 12-81. Using backup wrench, disconnect G794-2 & G794-3 hose assemblies from G810-1 & G811-1 line assemblies; cap fittings.
4. Refer to Figure 79-3. Remove D277-8 clamp or cut and discard safety wire securing A729 tube to G689-1 tank assembly scupper drain. Pull tube off of drain.
5. Disconnect airframe harness from MS28034-1 oil temperature sender.
6. Disconnect F723-1, F723-3, and F723-4 line assemblies from oil tank and associate components; cap fittings.
7. Remove nuts securing tank to firewall.
8. Remove hardware securing tank to F384-3 angles and remove tank through access door.

79-20 Oil Tank Assembly (continued)**B. Installation**

1. Torque check associated oil cooler and engine unions per § 20-33.
2. Refer to Figure 79-3. Position G689-1 tank assembly in helicopter and install hardware securing tank to F384-3 angles. Verify security.
3. Install nuts securing tank to firewall and special torque nuts per § 20-33.
4. Remove caps and connect F723-1, F723-3, and F723-4 line assemblies to tank and associate components. Using backup wrench, special torque line nuts per § 20-33.
5. Torque stripe fittings per Figure 5-1.
6. Connect airframe harness to MS28034-1 oil temperature sender. Verify security.
7. Secure A729 tube to tank scupper drain using D277-8 clamp; verify security.
8. Service engine oil per § 12-60.
9. Air-conditioned ships: Torque check nuts at firewall per § 20-33. Remove caps and connect G794-2 & G794-3 hose assemblies to G810-1 & G811-1 line assemblies. Using backup wrench, special torque hose nuts per § 20-33. Charge system per § 12-81.
10. Install tailcone cowling assembly per § 53-23.

79-21 Oil Temperature Sender**A. Removal**

1. Drain engine oil per § 12-60.
2. Remove tailcone cowling assembly per § 53-23.
3. Refer to Figure 79-3. Disconnect airframe harness from MS28034-1 oil temperature sender.
4. Remove sender from G689-1 tank assembly; discard packing. Tape tank opening.

B. Installation

1. Refer to Figure 79-3. Install (new) packing on MS28034-1 oil temperature sender. Remove tape, install sender in G689-1 tank, and special torque sender per § 20-33.
2. Connect airframe harness to sender; verify security.
3. Service engine oil per § 12-60.
4. Install tailcone cowling assembly per § 53-23.

79-22 Sight Gage

A. Removal

1. Drain engine oil per § 12-60.
2. Refer to Figure 79-3. Remove B563-2 sight gage from G689-1 tank assembly. Discard o-ring; tape tank opening.

B. Installation

1. Refer to Figure 79-3. Remove tape and verify G689-1 tank assembly interior is free of contaminants.
2. Lubricate (new) o-ring using A257-18 lubricant. Install o-ring on B563-2 sight gage, and install gage in tank. Special torque gage per § 20-33.
3. Service engine oil per § 12-60.

79-30 Engine Oil Cooler

A. Removal

1. Drain engine oil per § 12-60.
2. Refer to Figure 79-3. Remove hardware securing F649-1 oil cooler to F309-1 box assembly.
3. Support oil cooler without damaging oil cooler fins. Disconnect F723-2 and F723-4 line assemblies from oil cooler and associated components; cap fittings.

B. Installation

1. Refer to Figure 79-3. Install hardware securing F649-1 oil cooler to F309-1 box assembly.
2. Torque check associated oil cooler and engine unions per § 20-33.
3. Remove caps and connect F723-2 and F723-4 line assemblies to oil cooler and associated components. Using backup wrench, special torque line nuts per § 20-33.
4. Torque stripe fittings per Figure 5-1.
5. Service engine oil per § 12-60.

79-40 Engine Oil Filter

Maintain engine's oil system per RR300 OMM.

NOTE

During engine oil filter servicing, if filter is contaminated, replace engine oil cooler and flush oil lines.

79-50 Engine Oil Line Assemblies and Fittings**A. Removal**

1. Drain engine oil per § 12-60.
2. Refer to Figure 79-3. Remove hardware securing F723 line assembly clamps.
3. Disconnect line assembly from associated components; cap fittings. Remove line.

B. Installation

1. Refer to Figure 79-3. Torque check associated oil cooler and engine unions per § 20-33.
2. Remove caps and connect F723 line assembly to associated components. Using backup wrench, special torque line nuts per § 20-33.
3. Install hardware securing line assembly clamps. Verify security.
4. Torque stripe fittings per Figure 5-1.
5. Service engine oil per § 12-60.